

An Enhancement to the NA4 Gear Vibration Diagnostic Parameter

Harry J. Decker and Robert F. Handschuh
Vehicle Propulsion Directorate
U.S. Army Research Laboratory
Lewis Research Center
Cleveland, Ohio

James J. Zakrajsek
National Aeronautics and Space Administration
Lewis Research Center
Cleveland, Ohio

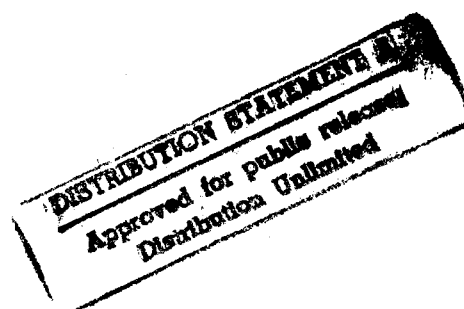
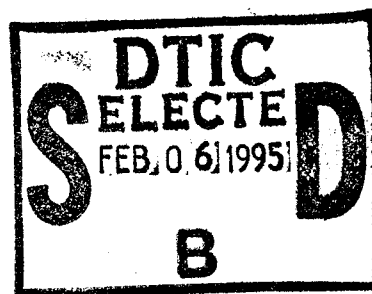

Prepared for the
18th Annual Meeting
sponsored by the Vibration Institute
Hershey, Pennsylvania, June 20-23, 1994



National Aeronautics and
Space Administration

19950201 068



DISCLAIMER NOTICE

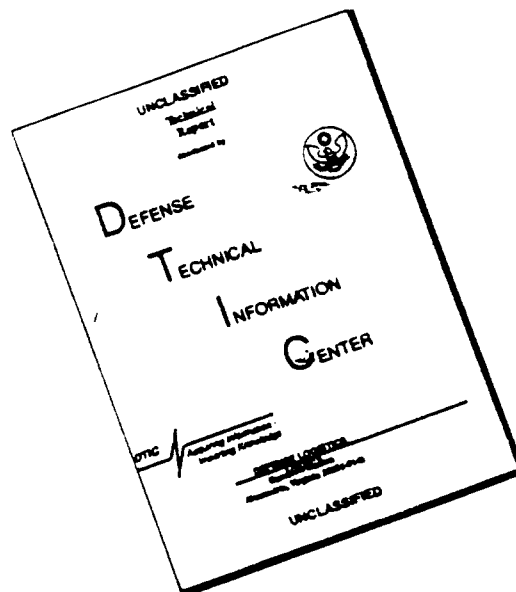

THIS DOCUMENT IS BEST QUALITY AVAILABLE. THE COPY FURNISHED TO DTIC CONTAINED A SIGNIFICANT NUMBER OF PAGES WHICH DO NOT REPRODUCE LEGIBLY.

An Enhancement to the NA4 Gear Vibration Diagnostic Parameter

Harry J. Decker and Robert F. Handschuh
Vehicle Propulsion Directorate
U.S. Army Research Laboratory
Lewis Research Center
Cleveland, Ohio 44035

James J. Zakrajsek
National Aeronautics and Space Administration
Lewis Research Center
Cleveland, Ohio 44035

† CIRCULARS 287500-0101

ABSTRACT

A new vibration diagnostic parameter for health monitoring of gears, NA4*, is proposed and tested. A recently developed gear vibration diagnostic parameter NA4 outperformed other fault detection methods at indicating the start and initial progression of damage. However, in some cases, as the damage progressed, the sensitivity of the NA4 and FM4 parameters tended to decrease and no longer indicated damage. A new parameter, NA4* was developed by enhancing NA4 to improve the trending of the parameter. This allows for the indication of damage both at initiation and also as the damage progresses. The NA4* parameter was verified and compared to the NA4 and FM4 parameters using experimental data from single mesh spur and spiral bevel gear fatigue rigs. The primary failure mode for the test cases was naturally occurring tooth surface pitting. The NA4* parameter is shown to be a more robust indicator of damage.

INTRODUCTION

Drive train diagnostics is becoming one of the most significant areas of research in rotorcraft propulsion. Fatigue failures of engine and transmission components were the cause of 32 percent of serious rotorcraft accidents[1]. These rotorcraft accident statistics illustrate the need for a health and usage monitoring (HUM) system to reliably determine if a fault exists

Dist	Special
A-1	

as early as possible.

Three gear fault detection methods based on analysis of the vibration signal are compared in this paper. All the methods use vibration data that is digitized and time averaged synchronous to the rotation of the gear being investigated. To prepare the digital data for time synchronous averaging, the signal was resampled (using linear interpolation) to provide a convenient number of data points for each revolution (1024). Each of the three fault detection methods discussed below were then applied to this pre-processed data.

The first method applied to the data is the popular FM4 parameter, as introduced by Stewart [2]. The FM4 parameter is included due to its wide acceptance in the industry. This parameter detects changes in the vibration resulting from damage limited to several teeth. A difference signal is created for a data record by removing the shaft and meshing frequencies, their harmonics, and the first order sidebands. The kurtosis (fourth statistical moment) is calculated for this difference signal. The FM4 parameter is non-dimensional and is calculated by dividing the kurtosis by the square of the variance of the difference signal. The value of FM4 for Gaussian noise is three, and the value of FM4 for the difference signal of a gearbox in good condition is also approximately three. As localized damage begins in a gearbox, the FM4 value increases.

The second method, NA4, was developed by Zakrajsek [3,4]. This parameter was developed to overcome a shortcoming of the FM4 parameter. As the occurrences of damage progresses both in number and severity, FM4 becomes less sensitive to the new damage. Two changes

were made to the FM4 parameter to develop the NA4 parameter as one that is more sensitive to progressing damage. One change is that FM4 is calculated from the difference signal while NA4 is calculated from the residual signal. The residual signal includes the first order sidebands that were removed from the difference signal. The second change is that trending was incorporated into the NA4 parameter. While FM4 is calculated as the ratio of the kurtosis of the data record divided by the square of the variance of the same data record, NA4 is calculated as the ratio of the kurtosis of the data record divided by the square of the average variance. The average variance is the mean value of the variance of all previous data records in the run ensemble. These two changes make the NA4 parameter a more sensitive and robust parameter. The NA4 parameter is calculated by

$$NA4 (M) = \frac{N \sum_i (r_i - \bar{r})^4}{\frac{1}{M} \sum_j [\sum_i (r_{ij} - \bar{r}_j)^2]^2}$$

where

- r residual signal
- \bar{r} mean value of residual signal
- N total number of data points in time record
- M current time record in run ensemble
- i data point number in time record
- j time record number in run ensemble

The third method applied to the data is the newly proposed parameter NA4*. While with NA4 the kurtosis for a data record is normalized by the squared average variance for the run ensemble, with NA4* the kurtosis for a data record is normalized by the squared variance

for a gearbox in good condition. This is a change in the trending of the data and is proposed to make a parameter that is more robust when progressive damage occurs. Following is a description of how the variance for a gearbox in good condition was determined.

In order to estimate the variance for a gearbox in good condition, a minimum number of data records of a run ensemble is required. In this work, a minimum of thirty records was chosen. The variance of the residual signal for all data records is calculated, as well as the mean and standard deviation. The mean is used as the current estimate of the variance for a gearbox in good condition. When the next data record is available, a judgement is made as to whether to include that data record as representative of a good gearbox. A gearbox with damaged gears will have a larger variance than one in good condition. The decision is based on an upper limit L , which in turn is dependent on the choice of a confidence coefficient Z , and is calculated by

$$L = \bar{x} + Z \frac{\sigma}{\sqrt{n}}$$

where

- \bar{x} is the mean value of previous variances
- Z is the Z value for a normal distribution
- σ is the standard deviation of previous variances
- n is the number of samples ($n \geq 30$)

The value for the Z parameter can be found in introductory statistics books [5]. If the current variance exceeds this limit, then it is judged that the variance of a good gearbox has already been determined, and that estimate is used for the remainder of the run ensemble. If the variance for the new data record does not exceed this limit, then the new data record is included into the data representing the gearbox in good condition.

The decision of what confidence coefficient is chosen is based on many factors. The most difficult trade-off is that of Type I or Type II errors. Type I errors can best be described as something wrong with no indication. A Type II error, on the other hand, reports damage when none is present.

APPARATUS AND GEAR DAMAGE REVIEW

The three parameters were tested using data obtained from gear fatigue test rigs at the NASA Lewis Research Center (figures 1 and 2). The purpose of these rigs is to study the effects of gear tooth design, gear materials and lubrication on the fatigue lives of aircraft quality gears. Vibration data from accelerometers mounted on each rig was captured with a personal computer using an analog to digital conversion board and an anti-aliasing filter. Both rigs use the closed loop torque regeneration principle. After the rigs are at operating conditions, the power system only has to supply enough power to overcome the losses in the system.

The spur gear test rig uses a pair of spur gears having 28 teeth, a pitch diameter of 88.9 mm

(3.50 in), and a face width of 6.35 mm (0.25 in). The gear faces are offset by 2.79 mm (0.11 in) to allow a higher surface stress without a corresponding increase in the bending stress. This, coupled with the ability to run on both sides of the profile, allows up to four fatigue failures per pair of gears. The pair transmits 143 kW (192 hp) as the gears rotate at 10,000 revolutions per minute.

The spiral bevel gear test rig uses a 12 tooth test pinion and a 36 tooth gear both having a 35 degree spiral angle, a 25.4 mm (1 in) face width, 90 degree shaft angle, and a 22.5 degree pressure angle. The pair transmits 537 kW (720 hp) as the pinion rotates at 14,400 revolutions per minute.

Spur Gear Damage

Data from three spur gear tests were obtained. Descriptions of the damage that occurred during these tests follow.

At 131 hours into run 1, damage was found on two teeth on the driver gear (one heavy and one moderate pitting). Both mating teeth on the driven gear were also found to be damaged (both heavy pitting). Figure 3a illustrates the heavy pitting damage on the driver and driven gears at 131 hours. Figure 3b illustrates the spalling and heavy pitting damage found on roughly one third of the teeth on both the driver and driven gears at the end of the run.

At the end of run 2, damage was found on four consecutive teeth on the driver gear (one heavy and two moderate pitting). Two of the three mating teeth on the driven gear were also

found to be damaged (both moderate pitting). This damage is shown in figure 3c.

Figure 3d shows the damage that was found at the end of run 3. After 74 hours, four consecutive teeth on the driver gear had damage. One was spalled, with two teeth having heavy and one tooth having moderate pitting. One of the four mating teeth on the driven gear was also found to be damaged (moderate pitting).

Spiral Bevel Gear Damage

Data from one spiral bevel test were obtained. Pictures of tooth damage on the pinion at various stages in the test are illustrated in figures 4a, 4b, and 4c. The rig was shut down a total of eight times to observe and document the damage as it progressed during the run. Only the results of three of these shutdowns will be discussed. At the first shutdown, at about five and one half hours into the test, a small pit was observed on one of the teeth on the test pinion as illustrated in figure 4a. At approximately twelve hours into the run, pitting started to appear on adjacent teeth, as seen in figure 4b. The pitting on the adjacent teeth continued to grow until it covered a majority of the face of three adjacent teeth on the pinion, and part of the face of another adjacent tooth. The run was stopped when one of the three heavily pitted pinion teeth was found to have fractured, losing one-third of the tooth, as illustrated in figure 4c. The fracture occurred between 16.16 and 17.79 hours into the test.

DISCUSSION OF RESULTS

The FM4, NA4, and several versions of the NA4* parameters were calculated for each of

the four fatigue runs. The versions of NA4* differ in the confidence coefficient selected for defining the limit value. Confidence coefficients of 70%, 75%, 80%, 85%, 87%, 90%, 95%, 97%, and 99% were used for comparison to determine how sensitive the NA4* parameter is to the chosen coefficient. In practice, an analyst would decide which confidence coefficient would be used. Most of the coefficients were removed from the figures for clarity. Following is a discussion of the results of applying the diagnostic parameters to the experimental data.

Spur Gear Tests

The comparisons between FM4, NA4 and a version of NA4* for test runs 1, 2, and 3 are shown in figures 5, 6, and 7, respectively. Due to limitations in the testing procedure, it is difficult and time consuming to correlate the actual condition of the gears with the vibration parameters that are calculated. Experience determines what an appropriate value for facility shutdown should be. At that time, if significant damage is present, the test is suspended, otherwise the test is restarted.

At 131 hours into test 1, the value of the NA4 parameter was very high, the rig was shut down, the gears removed, inspected and photographed. The gears were then re-installed and the test continued. From figure 5, it is assumed that a large amount of damage occurred around 112 hours into the test. NA4 and NA4* both react well to the damage by increasing to a value of 25 and only reducing to a value of 15 as localized damage progressed. FM4, however, peaked to a value of 5.4, then produced a Type I error when it dropped to its nominal value around 3. It is interesting to note that the NA4* parameter does not come

back down to the NA4 level and that the shapes of the curves are nearly identical. This implies that the irregularities of the curve is a function of just the numerator and not both the numerator and denominator. The drastic irregularities that occur after 170 hours are unique to this test and have not been observed in any other test.

The results from run 2 (figure 6) give the best example of the desired effect of using NA4* versus NA4. The most striking attributes of the curves are the difference in magnitudes and that the NA4* parameter did not give a Type I error. Again, notice that the overall shape of the curve is primarily a function of the numerator. It is interesting to note that the NA4 and FM4 parameters react at the same point in time, although with different sensitivities.

The results from run 3 (figure 7) show the same effect, although not as drastically. The important characteristic to note is that the NA4* parameter is most robust at indicating damage for both the initiation of damage as well as when damage progresses. On the other hand, the FM4 and NA4 parameters may return to levels indicating no damage when actually localized damage is progressing. As with the other runs, FM4 still shows the damage occurring, but it is more susceptible to misinterpretation than NA4 and NA4*.

Spiral Bevel Test

In the results of the spiral bevel test (figure 8), the FM4 parameter did not respond well, only hinting at some damage at about 16 hours. This was well after severe pitting and spalling was documented. For most of the run FM4 was producing a Type I error. The NA4 and NA4* curves give an early and robust indication that damage has occurred. In figure 8, the

effect of using different confidence intervals is best illustrated. In fact, it is suspected that damage started about 1.5 hours into the test when the NA4 and NA4* parameters have a value of near 5 for about 2 hours.

There were some differences in the versions of NA4* corresponding to the selected coefficients. Although a confidence coefficient of 80% is suggested, more experience is needed to determine which produces the best result.

SUMMARY AND CONCLUSIONS

The NA4* parameter has been developed as a diagnostic parameter that is robust for indicating damage both as localized damage begins and also as damage progresses. Data was obtained from four gear fatigue tests. The NA4* parameter was calculated for this data for comparison. The following conclusions can be made from the results presented.

- 1.) The new parameter, NA4*, enhances the successful NA4 parameter. In almost all cases, the NA4* parameter was more sensitive than the NA4 parameter.
- 2.) The NA4* parameter is less likely to produce a Type I error. That is, it is less likely to ignore existing damage.
- 3.) The NA4* parameter indicates damage both when localized damage is present and also

as damage progresses. The FM4 and NA4 parameters, however, can indicate no damage after localized damage has progressed.

REFERENCES

1. Astridge, D.G.: Helicopter Transmissions - Design for Safety and Reliability. Inst. Mech. Eng. Proc., G - J. Aerosp. Eng., vol 203, no. G2, 1989, pp.123-138.
2. Stewart, R.M.: Some Useful Data Analysis Techniques for Gearbox Diagnostics. Report MHM/R/10/77, Machine Health Monitoring Group, Institute of Sound and Vibration Research, University of Southampton, July 1977.
3. Zakrajsek, J.J., et al.: An Analysis of Gear Fault Detection Methods as Applied to Pitting Fatigue Failure Data. 47th Mechanical Failure Prevention Group, April 1993. NASA TM-105950, AVSCOM TR-92-C-035.
4. Zakrajsek, J.J., et al.: Application of Fault Detection Techniques to Spiral Bevel Gear Fatigue Data. 48th Mechanical Failure Prevention Group, April 1994. NASA TM-106467, ARL-TR-345.
5. Miller, Irwin, John E. Freund. Probability and Statistics for Engineers, Third Edition. Prentice-Hall, Inc. Englewood Cliffs, NJ, 1985.

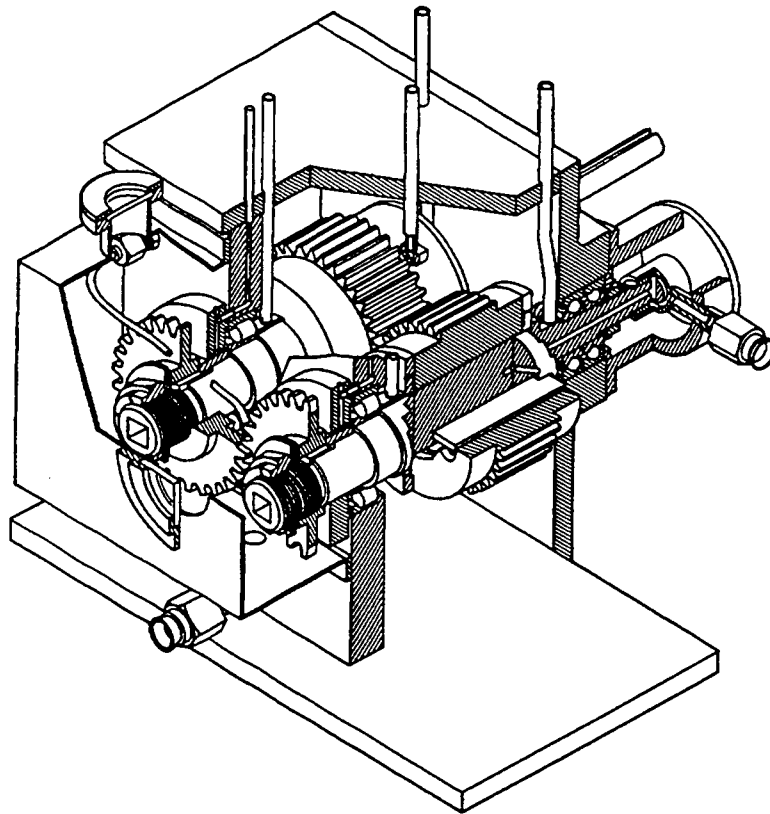

Figure 1.—Spur Gear Fatigue Rig.

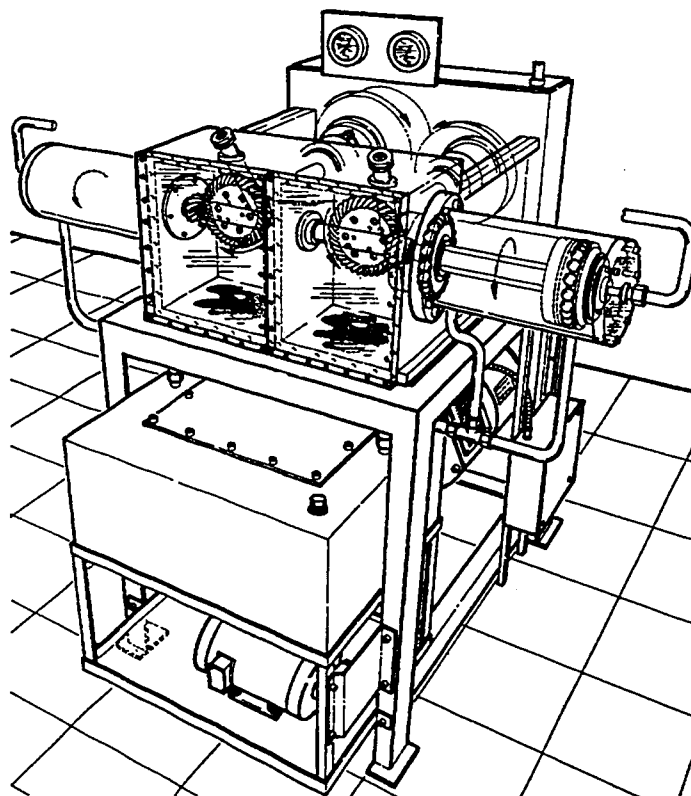

Figure 2.—Spiral Bevel Rig.

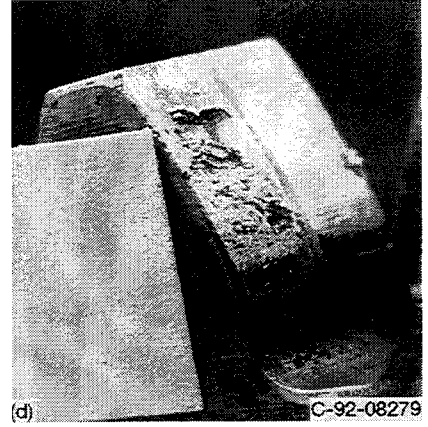
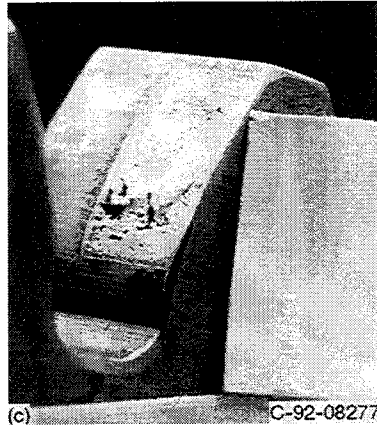
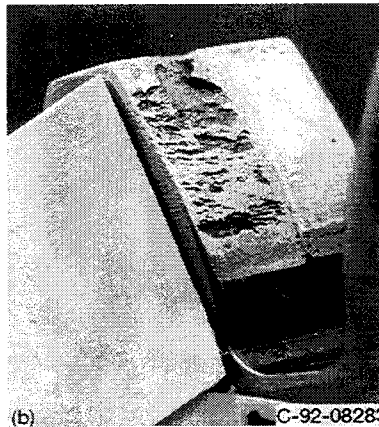
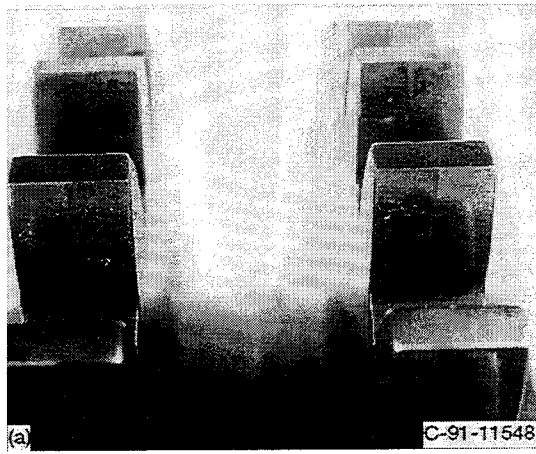

Figure 3.—(a) Heavy pitting on two teeth in Run 1 at 131 hr into run. (b) Example of spalling at end of Run 1. (c) Example of Run 2 moderate pitting. (d) Example of Run 3 heavy pitting.



Figure 4.—Damage to Spiral Bevel pinion. (a) At 5.05 hr. (b) At 12.03 hr. (c) At end of run.

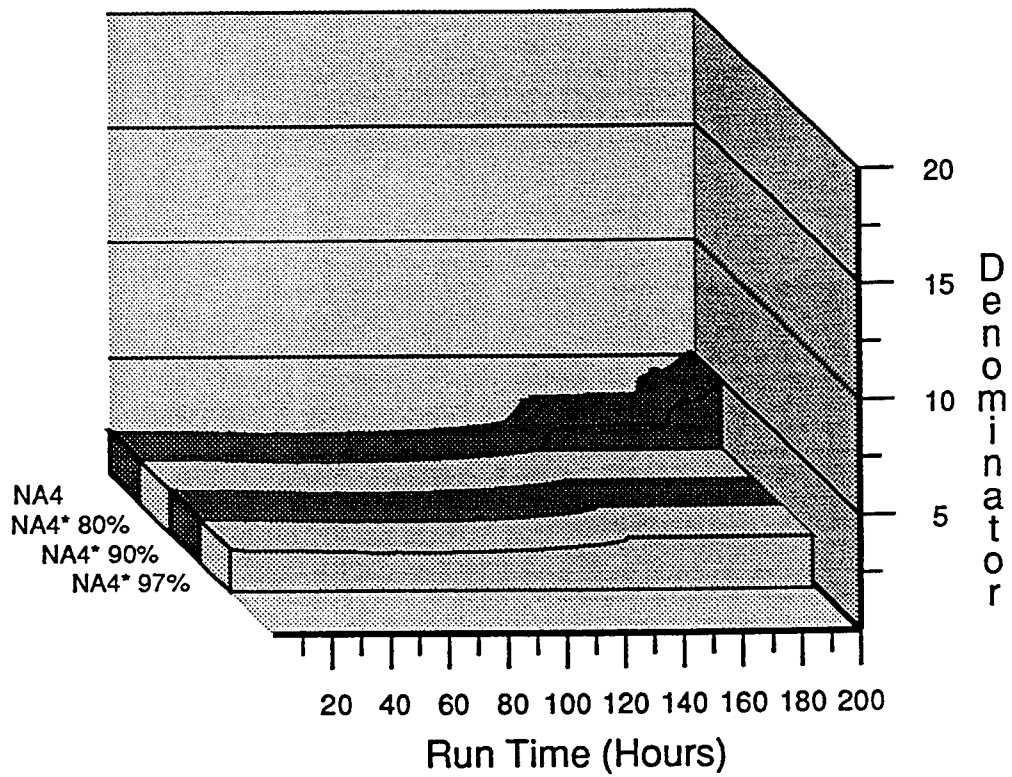
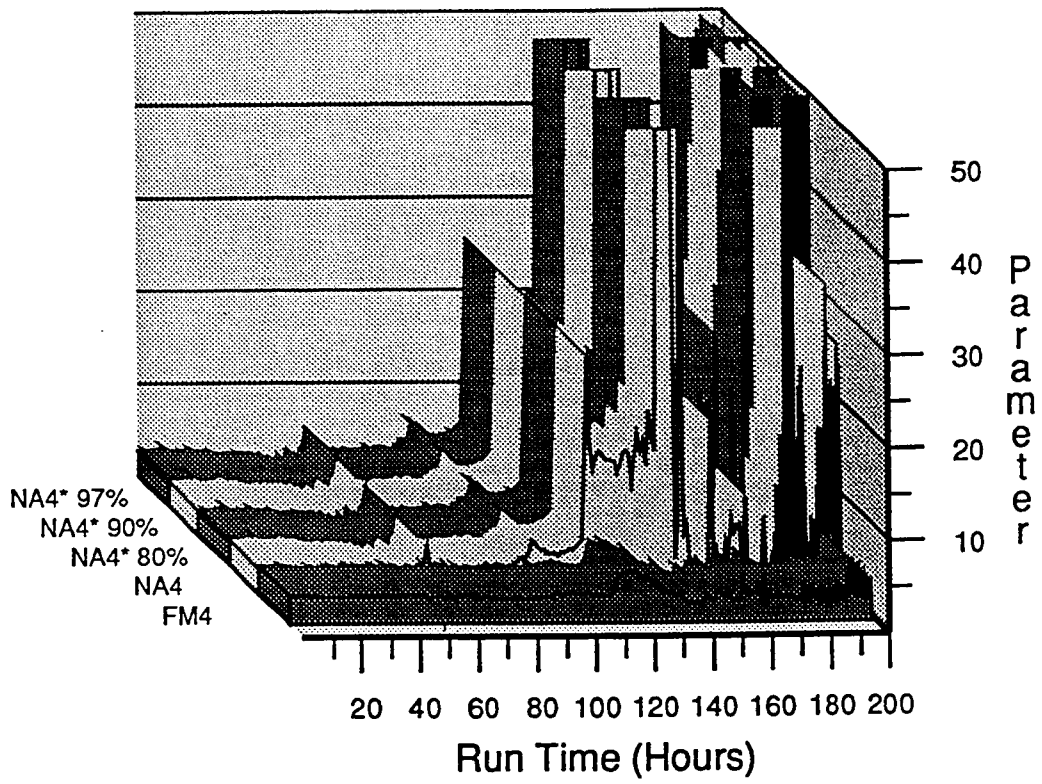

Figure 5.—Parameters for Spur Gear Run 1.

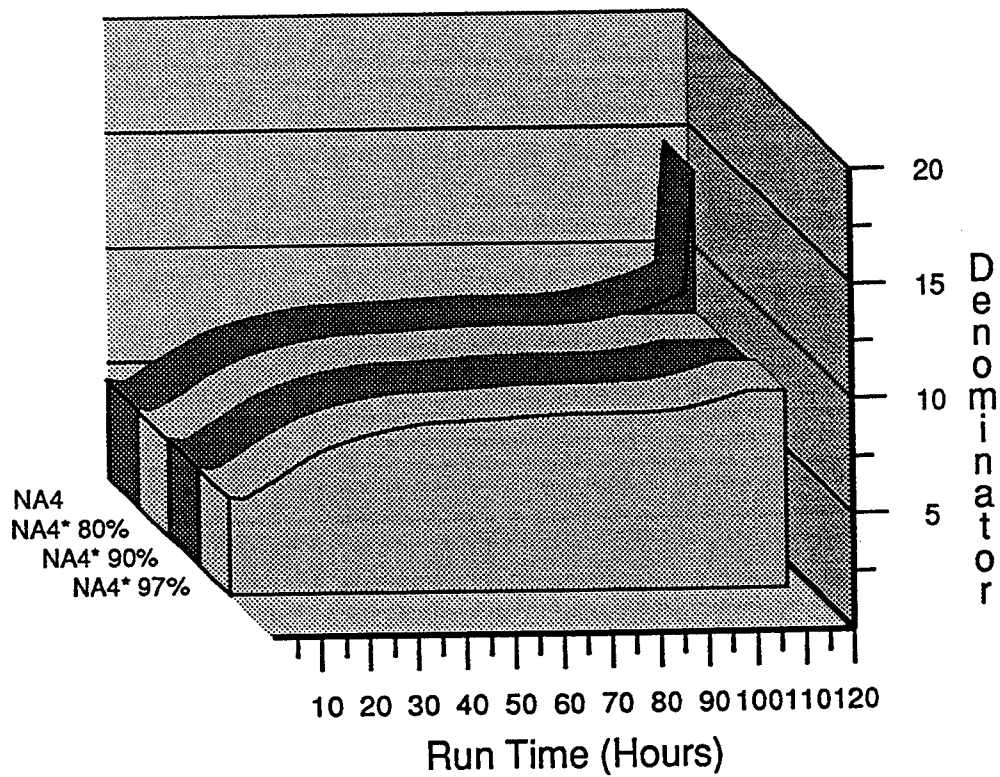
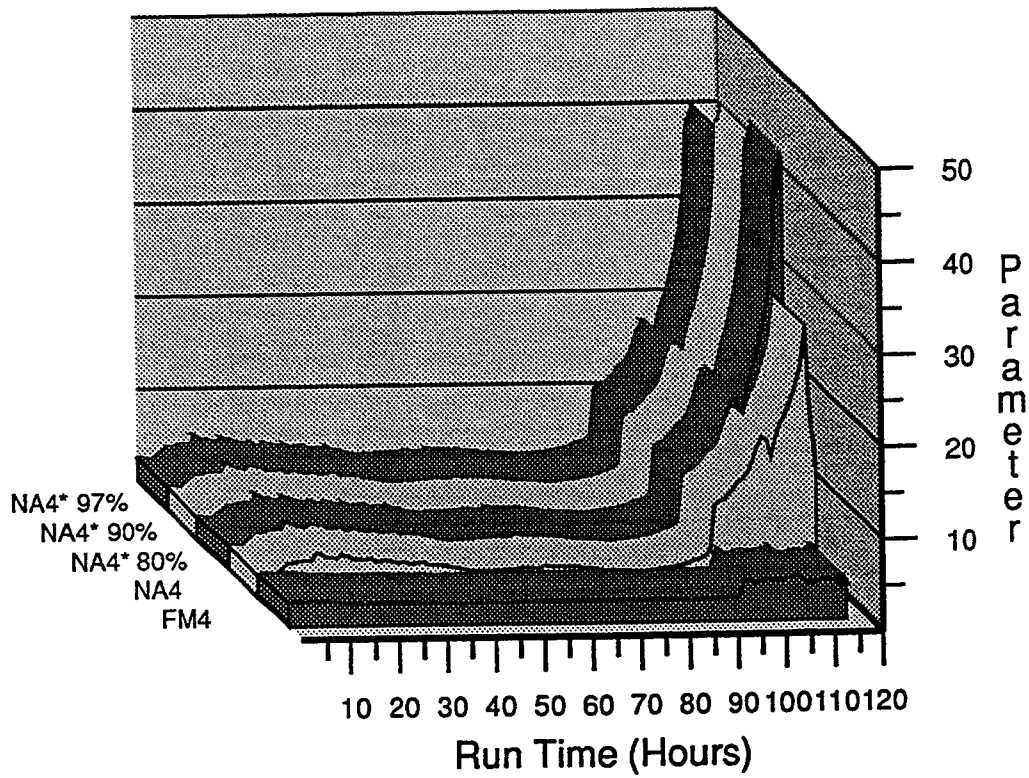

Figure 6.—Parameters for Spur Gear Run 2.

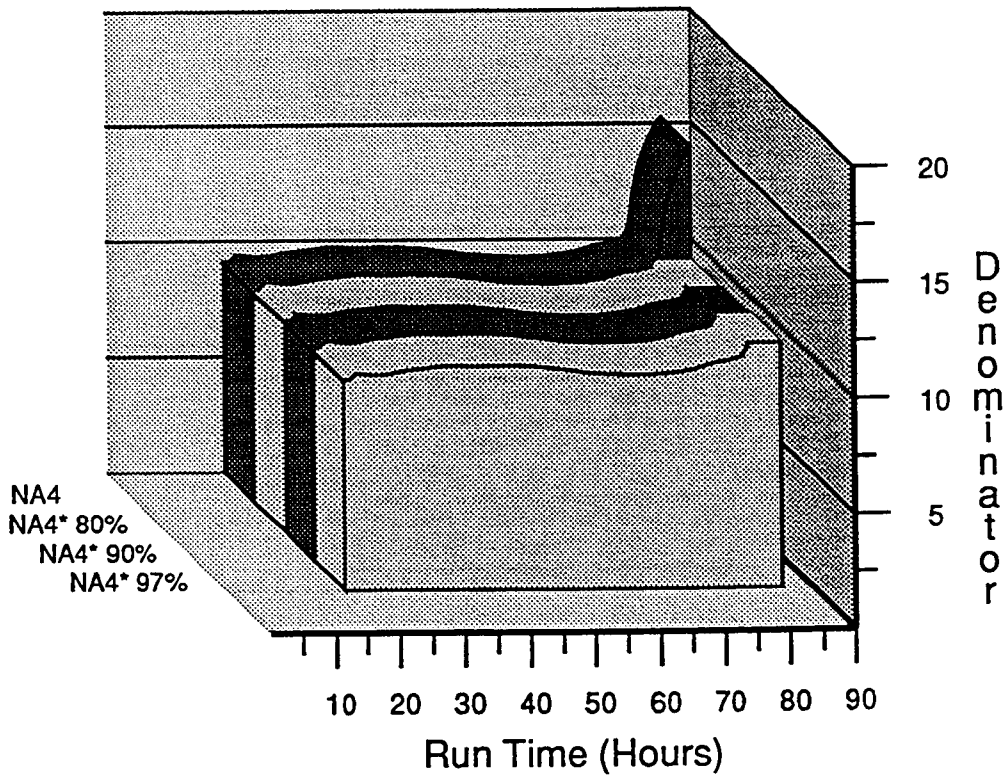
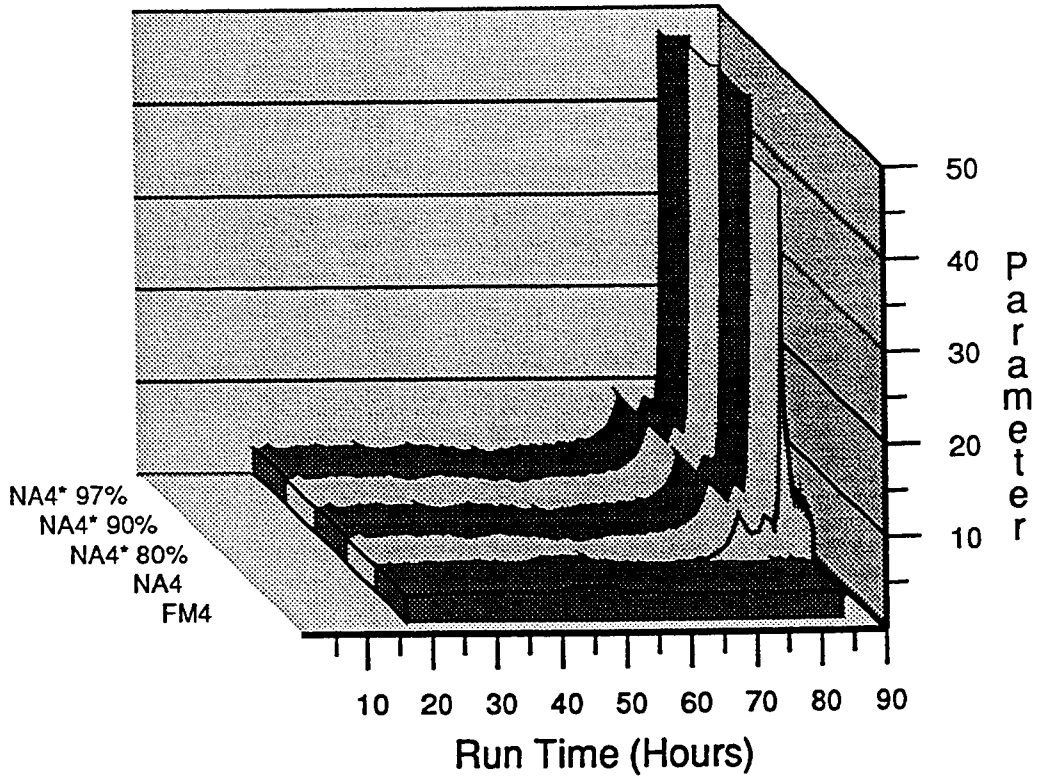

Figure 7.—Parameters for Spur Gear Run 3.

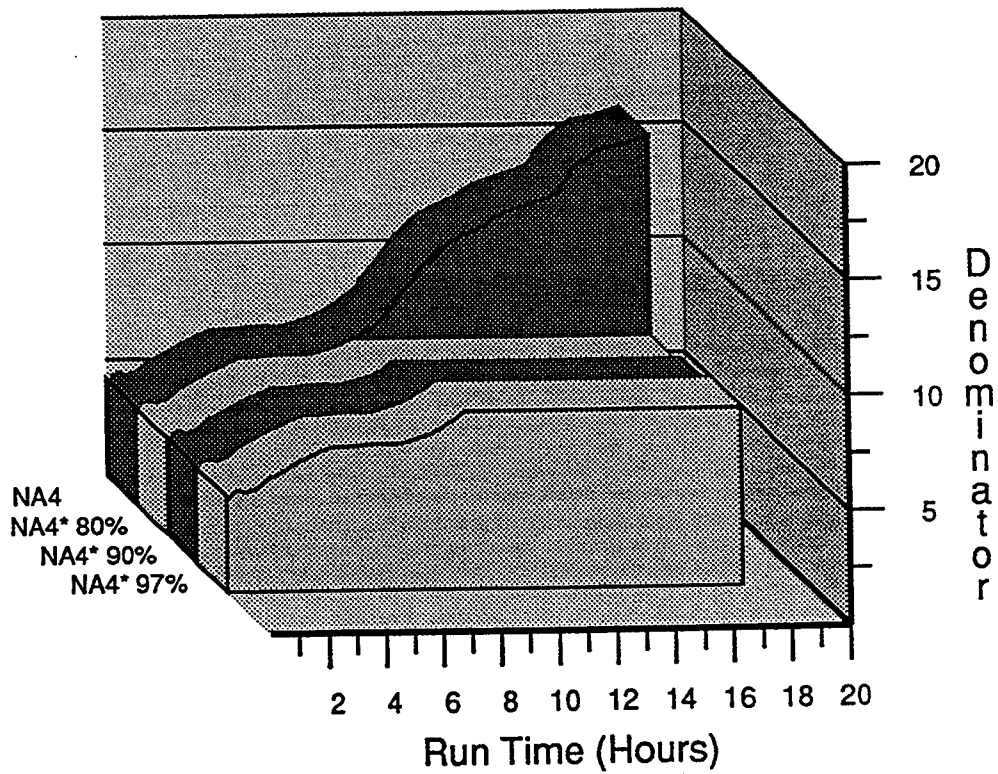
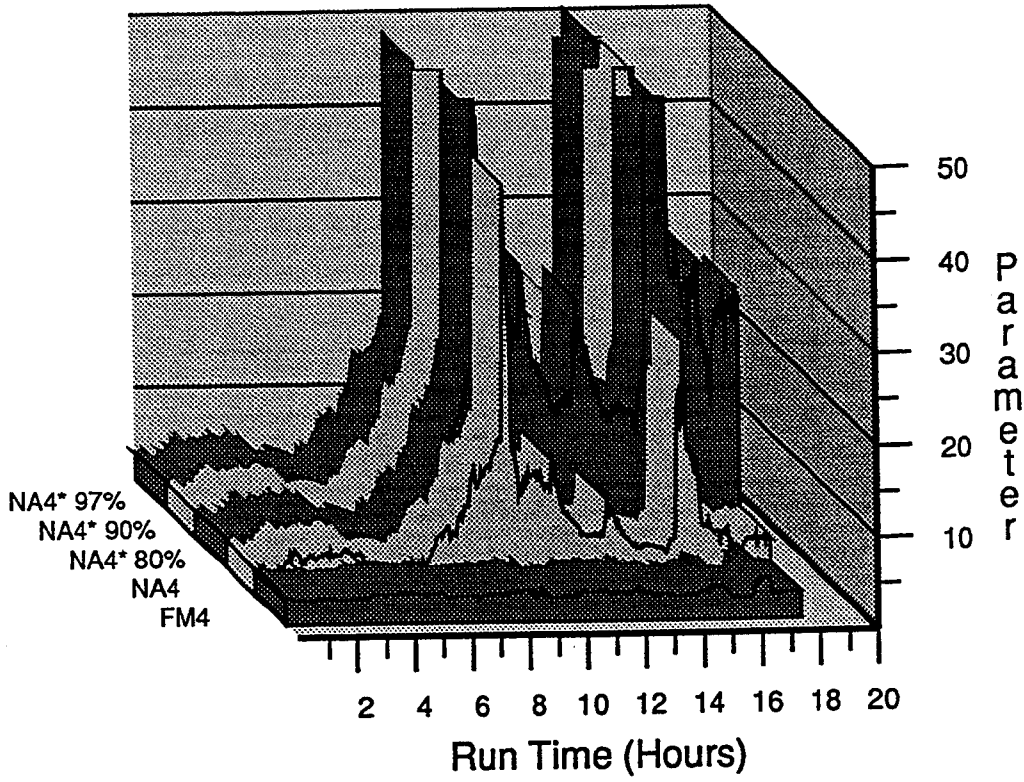

Figure 8.—Parameters for Spiral Bevel Run.

REPORT DOCUMENTATION PAGEForm Approved
OMB No. 0704-0188

Public reporting burden for this collection of information is estimated to average 1 hour per response, including the time for reviewing instructions, searching existing data sources, gathering and maintaining the data needed, and completing and reviewing the collection of information. Send comments regarding this burden estimate or any other aspect of this collection of information, including suggestions for reducing this burden, to Washington Headquarters Services, Directorate for Information Operations and Reports, 1215 Jefferson Davis Highway, Suite 1204, Arlington, VA 22202-4302, and to the Office of Management and Budget, Paperwork Reduction Project (0704-0188), Washington, DC 20503.

1. AGENCY USE ONLY (Leave blank)		2. REPORT DATE July 1994	3. REPORT TYPE AND DATES COVERED Technical Memorandum	
4. TITLE AND SUBTITLE An Enhancement to the NA4 Gear Vibration Diagnostic Parameter			5. FUNDING NUMBERS WU-505-62-36 1L162211A47A	
6. AUTHOR(S) Harry J. Decker, Robert F. Handschuh, and James J. Zakrajsek				
7. PERFORMING ORGANIZATION NAME(S) AND ADDRESS(ES) NASA Lewis Research Center Cleveland, Ohio 44135-3191 and Vehicle Propulsion Directorate U.S. Army Research Laboratory Cleveland, Ohio 44135-3191			8. PERFORMING ORGANIZATION REPORT NUMBER E-8708	
9. SPONSORING/MONITORING AGENCY NAME(S) AND ADDRESS(ES) National Aeronautics and Space Administration Washington, D.C. 20546-0001 and U.S. Army Research Laboratory Adelphi, Maryland 20783-1145			10. SPONSORING/MONITORING AGENCY REPORT NUMBER NASA TM-106553 ARL-TR-389	
11. SUPPLEMENTARY NOTES Prepared for the 18th Annual Meeting sponsored by the Vibration Institute, Hershey, Pennsylvania, June 20-30-1994. Harry J. Decker and Robert F. Handschuh, Vehicle Propulsion Directorate, U.S. Army Research Laboratory, NASA Lewis Research Center; and James J. Zakrajsek, NASA Lewis Research Center. Responsible person, Harry J. Decker, organization code 2730, (216) 1433-3564.				
12a. DISTRIBUTION/AVAILABILITY STATEMENT Unclassified - Unlimited Subject Category 37			12b. DISTRIBUTION CODE	
13. ABSTRACT (Maximum 200 words) A new vibration diagnostic parameter for health monitoring of gears, NA4*, is proposed and tested. A recently developed gear vibration diagnostic parameter NA4 outperformed other fault detection methods at indicating the start and initial progression of damage. However, in some cases, as the damage progressed, the sensitivity of the NA4 and FM4 parameters tended to decrease and no longer indicated damage. A new parameter, NA4* was developed by enhancing NA4 to improve the trending of the parameter. This allows for the indication of damage both at initiation and also as the damage progresses. The NA4* parameter was verified and compared to the NA4 and FM4 parameters using experimental data from single mesh spur and spiral bevel gear fatigue rigs. The primary failure mode for the test cases was naturally occurring tooth surface pitting. The NA4* parameter is shown to be a more robust indicator of damage.				
14. SUBJECT TERMS Gear; Fatigue; Diagnostic parameter; Failure prediction			15. NUMBER OF PAGES 19	
			16. PRICE CODE A03	
17. SECURITY CLASSIFICATION OF REPORT Unclassified	18. SECURITY CLASSIFICATION OF THIS PAGE Unclassified	19. SECURITY CLASSIFICATION OF ABSTRACT Unclassified	20. LIMITATION OF ABSTRACT	