

REPORT DOCUMENTATION PAGE

Form Approved
OMB No. 0704-0188

Public reporting burden for this collection of information is estimated to average 1 hour per response, including the time for reviewing instructions, searching existing data sources, gathering and maintaining the data needed, and completing and reviewing the collection of information. Send comments regarding this burden estimate or any other aspect of this collection of information, including suggestions for reducing this burden, to Washington Headquarters Services, Directorate for Information Operations and Reports, 1215 Jefferson Davis Highway, Suite 1204, Arlington, VA 22202-4302, and to the Office of Management and Budget, Paperwork Reduction Project (0704-0188), Washington, DC 20503.

1. AGENCY USE ONLY (Leave blank)		2. REPORT DATE 09/00/82	3. REPORT TYPE AND DATES COVERED	
4. TITLE AND SUBTITLE ASSESSMENT OF CONTAMINANT MIGRATION FROM POTENTIAL CONTAMINATION SOURCES			5. FUNDING NUMBERS	
6. AUTHOR(S)				
7. PERFORMING ORGANIZATION NAME(S) AND ADDRESS(ES) GERAGHTY & MILLER DENVER, CO			8. PERFORMING ORGANIZATION REPORT NUMBER 81342R06	
9. SPONSORING/MONITORING AGENCY NAME(S) AND ADDRESS(ES) STEARNS-ROGER ENGINEERING CORPORATION DENVER, CO			10. SPONSORING/MONITORING AGENCY REPORT NUMBER	
<div style="position: absolute; font-size: 2em; font-weight: bold; opacity: 0.5;">S D T I C E L E C T E F E B 0 6 1 9 9 5 S G D</div>				
11. SUPPLEMENTARY NOTES				
12a. DISTRIBUTION/AVAILABILITY STATEMENT APPROVED FOR PUBLIC RELEASE; DISTRIBUTION IS UNLIMITED			12b. DISTRIBUTION CODE	
13. ABSTRACT (Maximum 200 words) THIS INVESTIGATION, KNOWN AS THE POTENTIAL SOURCE AREA DEFINITION STUDY, HAD TWO PRIMARY OBJECTIVES. THE FIRST OBJECTIVE WAS A REVIEW AND EVALUATION OF KNOWN AND SUSPECTED POTENTIAL (SECONDARY) CONTAMINATION SOURCES AT ROCKY MOUNTAIN ARSENAL. THE SECOND OBJECTIVE WAS TO CLASSIFY EACH SOURCE INTO ONE OF THREE CATEGORIES: 1.) CURRENT PROBLEM AREA TO BE ADDRESSED, 2). AREAS WITH FUTURE POTENTIAL FOR CONTAMINANT MIGRATION THAT WILL REQUIRE MONITORING, 3.) NO EXISTING OR POTENTIAL PROBLEM LIKELY. THE PRIMARY OBJECTIVE OF THIS ASSESSMENT WAS OF THE MIGRATION OF CONTAMINANTS FROM SOURCE AREAS WITHIN RMA TOWARDS THE ARSENAL BOUNDARY. AREAS EXCLUDED FROM THIS STUDY ENCOMPASS BASIN A, BASIN F, THE NORTH AND NORTHWEST BOUNDARIES, THE SOUTH PLANTS, THE SANITARY AND CHEMICAL WASTE SEWERS, AND THE SEWAGE TREATMENT PLANT AND LAGOON. <div style="text-align: right; margin-top: 20px;">D T I C Q U A L I T Y I N S P E C T E D 3</div>				
14. SUBJECT TERMS SOIL SAMPLING, GROUNDWATER, DISPOSAL			15. NUMBER OF PAGES	
			16. PRICE CODE	
17. SECURITY CLASSIFICATION OF REPORT UNCLASSIFIED	18. SECURITY CLASSIFICATION OF THIS PAGE	19. SECURITY CLASSIFICATION OF ABSTRACT	20. LIMITATION OF ABSTRACT	

81342 R06
Original

ASSESSMENT OF CONTAMINANT MIGRATION FROM POTENTIAL CONTAMINATION SOURCES

GERAGHTY & MILLER, INC.
7100 BROADWAY, BLDG. 3-B
DENVER, COLORADO 80221

Accession For		
NTIS	CRA&I	<input checked="" type="checkbox"/>
DTIC	TAB	<input type="checkbox"/>
Unannounced		<input type="checkbox"/>
Justification		
By _____		
Distribution /		
Availability Codes		
Dist	Avail and/or Special	
A-1		



SEPTEMBER 1982 Rocky Mountain Arsenal
Information Center
Commerce City, Colorado

FILE COPY

PREPARED FOR

U.S. ARMY TOXIC & HAZARDOUS MATERIALS AGENCY
ABERDEEN PROVING GROUND, MARYLAND 21010
CONTRACT NO. DAAK-11-80-R-0012

UNDER SUBCONTRACT TO
STEARNS-ROGER
DENVER, COLORADO

	<p>US ARMY TOXIC AND HAZARDOUS MATERIALS AGENCY AND ROCKY MOUNTAIN ARSENAL</p>	
---	--	---

19950201 044

EXECUTIVE SUMMARY

An assessment was made of the contaminant migration potential from suspected secondary contamination sources on the Rocky Mountain Arsenal. Numerous Arsenal records were reviewed to identify sites where contaminants may have been stored, spilled or discharged. Thirty-two potential secondary contamination sources were identified and a summary of the activities at each is given. Geraghty & Miller, Inc. developed a Simplified Hazardous Site Ranking System to evaluate possible contaminant migration for each potential contamination source.

The Potential Source Area Definition Study did not include additional work on primary sources of contamination previously identified and investigated at Rocky Mountain Arsenal. Areas excluded from this study are Basin A, Basin F, the north and northwest boundaries, the South Plants, the sanitary and chemical waste sewers, and the sewage treatment plant and lagoon.

The potential contamination sites were ranked as follows:

- Group A Contamination present and migrating
- Group B Contamination present and migration unknown
- Group C Possible contamination present
- Group D Contamination unlikely

The evaluation concentrated on 20 sites in Groups A, B, or C having, or suspected of having, contamination.

Ninety-two soil and water samples were collected from 15

potential contamination sources according to the sampling protocol outlined in the Technical Plan. Twenty-two geologic samples were taken during the drilling of eight monitoring wells and seven soil borings. Fifty shallow soil samples were collected. Tests for chemical agents were performed on soil samples taken at three of these sites. Of the 20 water samples taken, 15 were from groundwater monitoring wells and five from surface-water bodies. In addition, results from numerous regional water-quality samples and selected soil samples were evaluated for determination of the possible presence and migration of contaminants.

Water samples were submitted directly to the Rocky Mountain Arsenal Analytical Systems Branch (ASB) for chemical analysis. Soil and geologic samples were first extracted with water by the S-Cubed Laboratory in California or with organic solvent by ASB. The extracts were then analyzed by ASB for the specified constituents. The solvent extraction method was used to approximate the mass of contaminant in the soil and the water extraction procedure was used to estimate the quantity of contaminant that might be expected to leach from the soil.

Samples were analyzed for common cations (Ca, Mg, K, and Na), heavy metals (As, Cd, Cu, Fe, Mn, and Hg), common anions (Cl, F, NO_3 and SO_4), and organic compounds (DBCP, DIMP, p-chlorophenylmethyl sulfide, sulfoxide, and sulfone - CPMS, CPMSO, CPMSO₂, Aldrin, Dieldrin, Endrin, oxathiane - OXAT, dithiane - DITH, and benzothiazole - BTA). At locations where chemical agent residues were possible or there were no clues about the types of possible contaminants, a gas chromatograph/mass spectrometer screen was made. The

analytical program was designed to detect chemical agents, their decomposition products, or other chemical contaminants suspected to have originated at a given site.

Additional information about the location and timing of various disposal and storage activities at Rocky Mountain Arsenal was derived from a study of aerial photographs. The photographs, supplied by Ms. Marlene B. Lindhardt, U.S. Army Toxic and Hazardous Materials Agency, and Mr. Ed Berry, Rocky Mountain Arsenal, were used to compile a history of boundary changes at Rocky Mountain Arsenal over the last 40 years. As in aid in interpreting the photographs, interviews with Mr. George Donnelly, retired Director of Facilities and Mr. George Buxton, retired from the Quality Assurance Office, were conducted.

Twelve Group D sites (contamination unlikely) were not included in field sampling. No evidence of contaminant migration was expected at these sites because of:

- a. Data included in previous reports
- b. The nature of the activity at the site
- c. No documented or suspected occurrence of contaminants having been released

Most of the 12 sites dealt with outside storage areas, burn pits, TX study and disposal areas, or areas where activities were widely dispersed.

The 32 sites were identified and grouped into the following:

- | | |
|------------|---|
| Category I | Current problem to be addressed, ie., contamination moving across the Arsenal boundary above the regulated standard |
|------------|---|

TABLE OF CONTENTS

	PAGE
EXECUTIVE SUMMARY	
CHAPTER 1 INTRODUCTION	
1.1 Purpose and Scope of Report	1-1
1.2 Background	1-3
CHAPTER 2 DEVELOPMENT OF A HAZARDOUS SITE RANKING SYSTEM AND PRELIMINARY GROUPING OF POTENTIAL CONTAMINATION SOURCES	
2.1 Introduction	2-1
2.2 Development of a Simplified Hazardous Ranking System	2-2
2.3 Application of the Simplified Hazardous Site Ranking System	2-3
2.4 Grouping of Potential Contamination Sources at Rocky Mountain Arsenal	2-5
CHAPTER 3 TECHNICAL PLAN	
3.1 Introduction	3-1
3.2 Implementation Methods	3-1
3.3 Technical Plan Summary	3-8
3.4 Safety Program	3-8
CHAPTER 4 HISTORY OF POTENTIAL CONTAMINATION SOURCES AND TECHNICAL PLAN RESULTS	
4.1 Introduction	4-1
4.2 Background Soil Chemistry On Rocky Mountain Arsenal	4-2
4.3 Evaluation of Section 26	4-5
4.4 Evaluation of Section 35	4-10
4.5 Evaluation of Section 25	4-14
4.6 Evaluation of Section 30	4-18
4.7 Evaluation of Section 31	4-26
4.8 Evaluation of Section 6	4-31
4.9 Evaluation of Section 36	4-36
4.10 Evaluation of Sections 11 and 12	4-39
4.11 Evaluation of Section 3	4-45
4.12 Evaluation of Section 4	4-50
4.13 Group D Sites Not Addressed By Technical Plan	4-56
CHAPTER 5 CATEGORIZING CONTAMINATION SOURCES	
CHAPTER 6 CONCEPTUALIZED TECHNICAL PLAN FOR CONFIRMATORY STAGE	
6.1 Introduction	6-1
6.2 Conceptual Plan for Site 11	6-1
6.3 Conceptual Plan For Site 26	6-3

TABLE OF CONTENTS (CONTD)

	PAGE
6.4 Conceptual Plan For Sites 24 and 30	6-4
6.5 Conceptual Plan For Site 9	6-4
6.6 Conceptual Plan For Site 4	6-4
6.7 Conceptual Plan For Site 32	6-5
6.8 Development of a Phase III Technical Plan	6-5

REFERENCES CITED

APPENDIX A

APPENDIX B

APPENDIX C

APPENDIX D

BIBLIOGRAPHY

LIST OF FIGURES

		PAGE
1-1	Rocky Mountain Arsenal Potential Sources Area Definition Study Flow Chart	1-2
1-2	History of Boundary Changes for Rocky Mountain Arsenal, Denver, Colorado	1-6
2-1	Simplified Hazardous Ranking System Developed by Geraghty & Miller, Inc.	2-4
2-2	Possible Source Areas Containing Contaminated Material	2-6
2-3	Classification of Potential Contamination Sites from Phase I Groups to Phase II Categories, Rocky Mountain Arsenal, Denver, Colorado	2-9
4-1	Location of Control Soil Samples Rocky Mountain Arsenal, Denver, Colorado	4-3
4-2	Potential Contamination Sources in Section 26, Rocky Mountain Arsenal, Denver, Colorado	4-6
4-3	Potential Contamination Sources in Section 35, Rocky Mountain Arsenal, Denver, Colorado	4-11
4-4	Potential Contamination Sources in Section 25, Rocky Mountain Arsenal, Denver, Colorado	4-15
4-5	Potential Contamination Sources in Section 30, Rocky Mountain Arsenal, Denver, Colorado	4-19
4-6	Potential Contamination Sources in Section 31, Rocky Mountain Arsenal, Denver, Colorado	4-27
4-7	Potential Contamination Sources in Section 6, Rocky Mountain Arsenal, Denver, Colorado	4-32
4-8	Potential Contamination Sources in Section 36, Rocky Mountain Arsenal, Denver, Colorado	4-37
4-9	Potential Contamination Sources in Sections 11 and 12, Rocky Mountain Arsenal, Denver, Colorado	4-40
4-10	Potential Contamination Sources in Section 3, Rocky Mountain Arsenal, Denver, Colorado	4-46
4-11	Potential Contamination Sources in Section 4, Rocky Mountain Arsenal, Denver, Colorado	4-51

LIST OF TABLES

	PAGE
2-1 Grouping of Potential Contamination Sites Identified in the Potential Source Area Definition Study, Rocky Mountain Arsenal	2-7
3-1 Organic Compounds and Inorganic Constituents Requested For Analysis by Geraghty & Miller, Inc.	3-4
4-1 Results of Chemical Analysis for Control Soil Samples	4-2
4-2 Results of Chemical Analysis for Site 4	4-8
4-3 Results of Chemical Analysis for Site 25	4-12
4-4 Results of Chemical Analysis for Site 31	4-14
4-5 Results of Chemical Analysis for Site 26	4-17
4-6 Results of Chemical Analysis for Site 6	4-21
4-7 Results of Chemical Analysis for Site 7	4-23
4-8 Results of Chemical Analysis for Site 17	4-24
4-9 Results of Chemical Analysis for Site 9	4-28
4-10 Results of Chemical Analysis for Site 18	4-30
4-11 Results of Chemical Analysis for Site 19	4-33
4-12 Results of Chemical Analysis for Site 20	4-35
4-13 Results of Chemical Analysis for Site 23	4-36
4-14 Results of Chemical Analysis for Site 32	4-38
4-15 Results of Chemical Analysis for Site 24	4-42
4-16 Results of Chemical Analysis for Site 30	4-44
4-17 Results of Chemical Analysis for Site 11	4-48
4-18 Results of Chemical Analysis for Site 2	4-52
4-19 Results of Chemical Analysis for Site 3	4-55
5-1 Category I and II Sites For Which Additional Study And/Or Monitoring Is Recommended, Rocky Mountain Arsenal	5-2

CHAPTER 1

INTRODUCTION

1.1 PURPOSE AND SCOPE OF REPORT

This investigation, known as the Potential Source Area Definition Study, had two primary objectives. The first objective was a review and evaluation of known and suspected potential (secondary) contamination sources at Rocky Mountain Arsenal, Denver, Colorado. The second objective was to classify each source into one of three categories (Figure 1-1). The three are:

Category I

Current problem area to be addressed, i.e., contamination migrating across the Arsenal boundary above the regulated standard

Category II

Areas with future potential for contaminant migration that will require monitoring

Category III

No existing or potential problem likely, thus no action required at this time

The primary objective of the Potential Source Area Definition Study was the assessment of the migration of contaminants from source areas within Rocky Mountain Arsenal towards the Arsenal boundary. Most of the potential source areas have been unused for years. The assessments of source areas by Geraghty & Miller, Inc. pertain only to the potential for

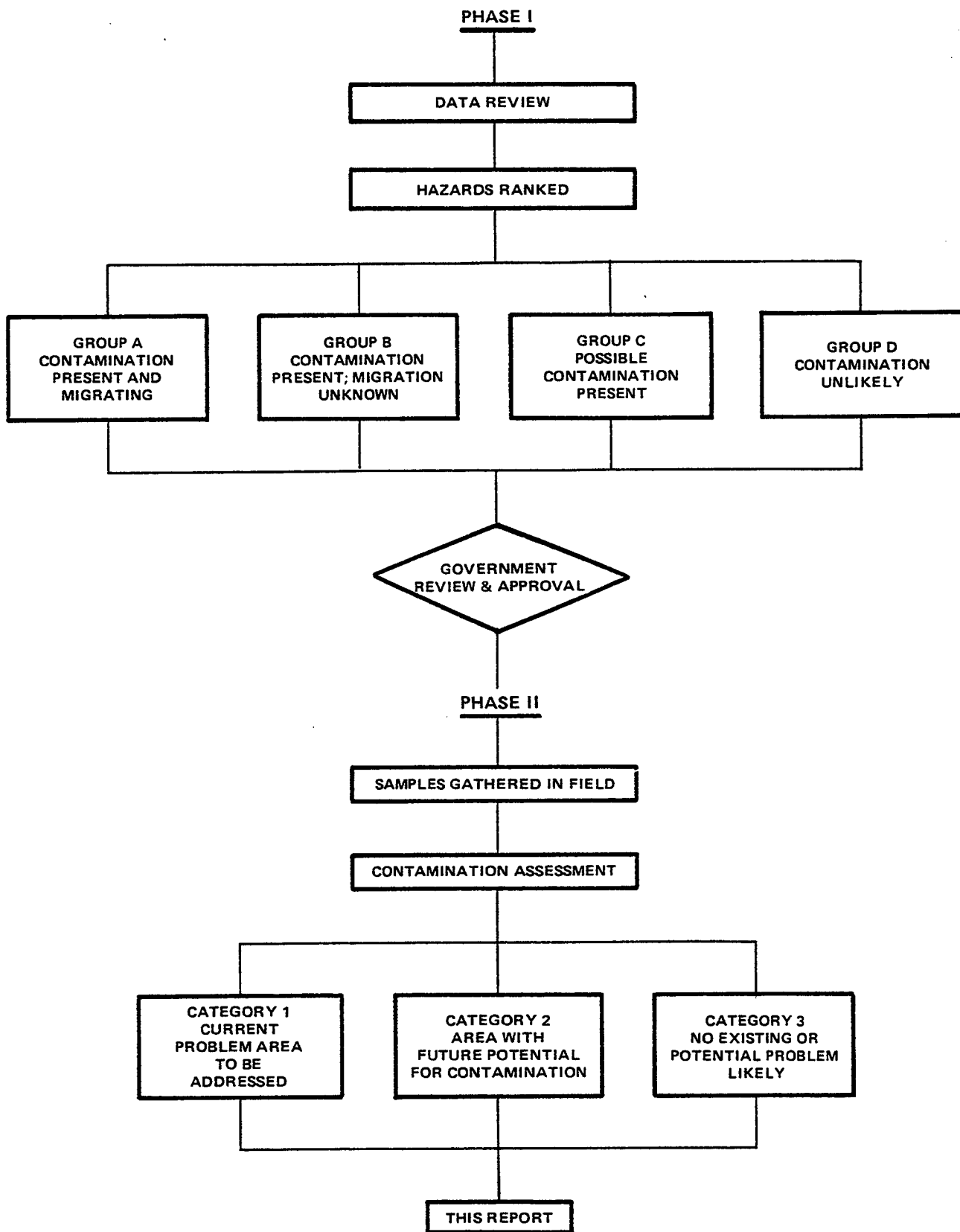

FIGURE 1-1
 ROCKY MOUNTAIN ARSENAL POTENTIAL SOURCE AREA
 DEFINITION STUDY FLOW CHART

migration of contaminants from a source area. The assessments are not intended to be indicative of the suitability of any given source area for alternative land uses.

The Potential Source Area Definition Study contract precluded any additional work on primary sources of contamination that have been previously identified and investigated at Rocky Mountain Arsenal. The excluded areas encompass Basin A, Basin F, the north and northwest boundaries, the South Plants, the sanitary and chemical waste sewers, and the sewage treatment plant and lagoon.

1.2 BACKGROUND

The Potential Source Area Definition Study was divided into two stages and four phases. Stage I was designated as the exploratory stage with two phases. Phase I included a review of available data on potential sources, development of a hazardous site ranking system to evaluate potential sources, and the formulation of a Technical Plan to be performed in Phase II.

Phase II of the Potential Source Area Definition Study consisted of three main activities--implementation of the Technical Plan proposed in Phase I, an assessment of the migration potential of contamination found, and recommendations for confirmatory sampling and analysis.

Based on the findings resulting from Stage I, the government will determine if additional work is required. Stage II, the confirmatory stage, would also be conducted in two phases.

Phase III would characterize migration vectors and travel times of contaminants to the installation boundary. Phase IV would be detailed assessment of the contamination sources and of the contaminant migration potential.

Ninety-two samples were collected from 15 potential contamination sources according to the sampling protocol outlined in the government approved Technical Plan. Twenty-two geologic samples were taken during the drilling of eight monitoring wells and seven soil borings, and 44 shallow soil samples and sediment samples were collected. Tests for chemical agents were performed on samples taken at three of the sites. A total of 20 water samples were taken, 15 from groundwater monitoring wells and five from surface water bodies. In addition, results from numerous regional water quality samples, collected by Rocky Mountain Arsenal personnel during the second quarter of 1982, and selected soil samples were evaluated for determination of possible presence and migration of contaminants from potential contamination sources at Rocky Mountain Arsenal.

Analytical results for the parameters specified in the Technical Plan were supplied by the Rocky Mountain Arsenal ASB. At one site, 13 replicate geologic and groundwater samples were given to Mr. Gene Kauffman of Shell Chemical Company for analysis by the Shell laboratory.

Interviews with Mr. George Donnelly, retired Director of Facilities, and Mr. George Buxton, retired from the Quality Assurance Office, were also conducted. Continued analysis of aerial photographs, supplied by Ms. Marlene B. Lindhardt, U.S. Army Toxic and Hazardous Materials Agency, and Mr. Ed

Berry, Rocky Mountain Arsenal, gave additional information as to the location and timing of various activities at Rocky Mountain Arsenal relative to the definition of potential contamination sources. The photographs were used to compile a history of boundary changes at Rocky Mountain Arsenal over the last 40 years as shown in Figure 1-2. From 1942 to 1952, the Rocky Mountain Arsenal covered the area shown in Figure 1-2-a. After construction of the North Plant in 1952, the northern boundary of the Arsenal was extended one mile northward, Figure 1-2-b. After 1964, several Sections at the southwest corner of the Arsenal were released, leaving the boundary as shown in Figure 1-2-c. One Section of land near the southwest corner (Section 10) was released about 1970 for airport expansion, resulting in the Arsenal boundary as it exists today.

Chapter 2 of this report summarizes the development of a hazardous site ranking system which was used to categorize contamination sources. Geraghty & Miller, Inc. reviewed several existing hazards ranking models before developing a simplified hazardous site ranking system utilizing a project team approach. Also included in this chapter is the grouping of 32 potential contamination sources which had been identified from a review of numerous reports and aerial photographs. A preliminary evaluation of these potential contamination sources was made to help formulate the Technical Plan to be performed in Phase II.

The methods used to implement the Technical Plan are presented in Chapter 3. Field activities and laboratory requirements and procedures are outlined. The data management program used to enter the collected data in the

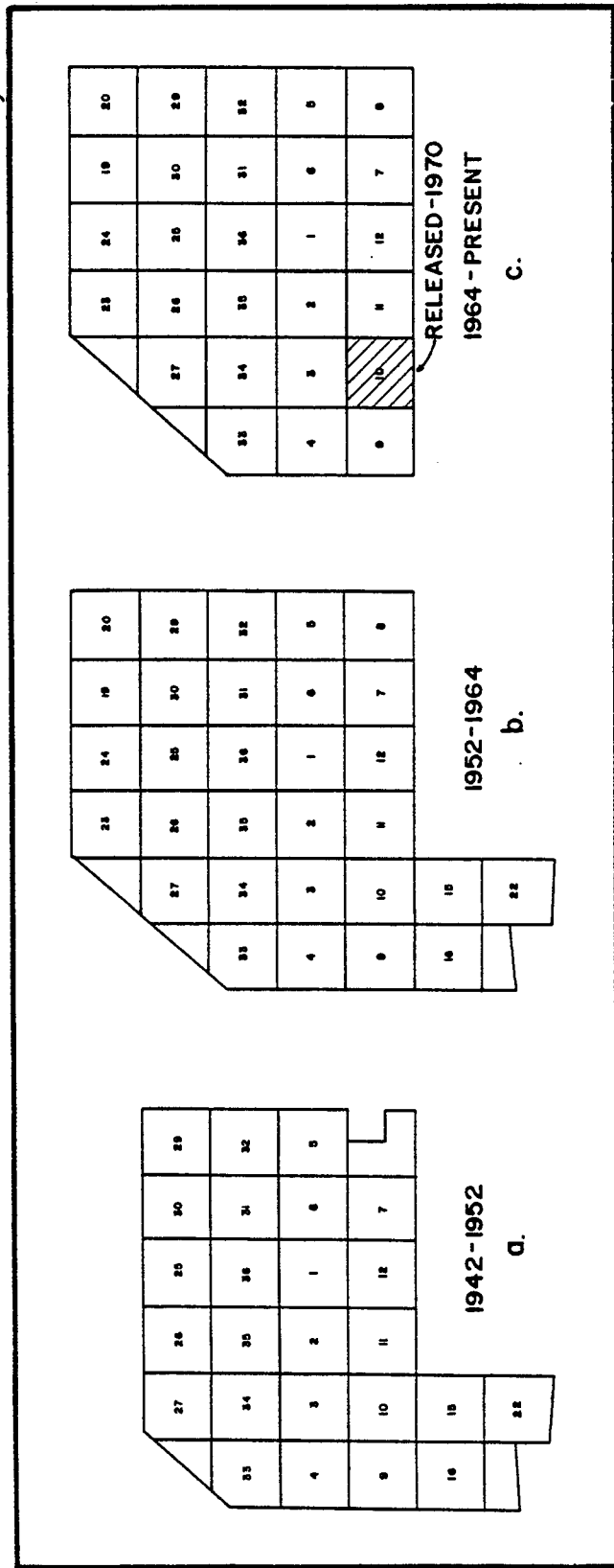

FIGURE 1-2
HISTORY OF BOUNDARY CHANGES
FOR ROCKY MOUNTAIN ARSENAL, DENVER, COLORADO

U.S. Army Toxic and Hazardous Materials Agency Installation Restoration system is also given.

Chapter 4 contains the results of the exploratory evaluation of each of the 20 potential contamination sources identified during Phase I as being in Group A, B, or C. General hydrogeologic conditions are given for each section of the Rocky Mountain Arsenal in which a potential contamination source is located. A brief history of each site is given along with a summary of the sampling program approved in the Technical Plan. The results of the analytical testing performed at each site and a discussion of these results are also included in Chapter 4.

The approved Technical Plan did not include field sampling at the 12 Group D sites. No evidence of contaminant migration was expected at these sites because of the following factors:

- a. Data included in previous reports
- b. The nature of the activity at each site
- c. No documented or suspected occurrences of contaminants being released

Most of the 12 sites dealt with outside storage areas, burn pits, TX study and disposal areas, and areas where activities were widely dispersed.

Assessments of contaminant migration from seven potential contamination sites are evaluated in Chapter 5. These evaluations were made on sites having known releases of contaminants by any route as confirmed by recent analytical testing. The division of these sites, the second objective of the Potential Source Area Definition Study, into the three

categories defined in Phase I is also given in Chapter 5.

Recommendations for confirmatory work to be completed during Stage II are presented in Chapter 6 for those sites requiring additional study to characterize transport pathways and contaminant migration. At the completion of Stage II, a quantitative assessment of the contaminant sources and migration potential will be made.

The geologist logs for the eight monitoring wells and seven soil borings drilled by Geraghty & Miller, Inc. during Phase II are given in Appendix A. Additional information is given in Appendix B for using the Simplified Hazardous Site Ranking System developed during Phase I. The evaluation forms for those sites evaluated by the Simplified Hazardous Site Ranking System are given in Appendix C.

General physical and hydrologic information on each Section of Rocky Mountain Arsenal is presented on a series of four drawings labeled "A" through "D", included in Appendix D. The series of drawings labeled "A" show the general location of each potential site (if one exists) within a Section, the location of existing monitoring wells, and the location of a geologic cross-section. The "B" series of drawings shows the water table contours for the area (Romero and Ward, 1981), groundwater flow direction, and the potential site locations. The "C" series of drawings shows the potential site locations, the boundaries of known areas of groundwater contamination, and the location of abandoned farm wells. Geologic cross-sections for those Sections containing potential contamination sites are shown on the "D" series of drawings. The areas have been identified on the basis of

reports, interviews, and evaluation of aerial photographs, but the delineation of the potential site locations as shown on the drawings in this report should not be construed as representing definitive boundaries.

A bibliography of Rocky Mountain Arsenal reports reviewed but not cited follows the appendices.

CHAPTER 2

DEVELOPMENT OF A HAZARDOUS SITE RANKING SYSTEM AND PRELIMINARY GROUPING OF POTENTIAL CONTAMINATION SOURCES

2.1 INTRODUCTION

The first task of the study was in-depth data review. The RMA Information Center (RIC), which contains over 900 maps and documents on the Arsenal, was consulted. Interviews and field tours were conducted. Sufficient data were obtained to provide a Section by Section data base. This includes the history of past events and land uses and the current geologic and hydrologic conditions. The data review is the basis for the entire study, especially the identification and classification of the 32 potential contamination source sites.

To classify each potential source into one of three categories, a hazardous site ranking system was developed. Several existing ranking models for determining remedial action priorities at hazardous waste disposal sites were reviewed and supplied valuable input to the modified ranking system. The potential source areas at Rocky Mountain Arsenal were placed into one of four groups according to the conditions present. A preliminary evaluation of each potential contamination source was then made using the ranking system to guide the formulation of the Technical Plan.

2.2 DEVELOPMENT OF A SIMPLIFIED HAZARDOUS RANKING SYSTEM

The method used by Geraghty & Miller, Inc. in the ranking of hazardous sites was the project team approach incorporating the required disciplines. The expertise of the project team allows for the application of a simplified subjective version of the detailed ranking models proposed to date. This approach greatly facilitates preliminary ranking of sites where there are insufficient data to apply other models or where conditions are such that other models do not apply.

The simplified ranking system developed by Geraghty & Miller, Inc. utilizes a subjective rating factor analysis for site-specific conditions similar to those at Rocky Mountain Arsenal. This ranking system differs from previous models in four ways. First, it is a subjective team approach, requiring the project team (user) to be qualified in evaluating various factors. Second, the concept of a target characteristic used in other models has been omitted, because it is the ultimate goal of any contamination containment system to preclude any migration off an installation regardless of possible targets. Third, another characteristic deleted from previous models is the quantity of the contaminant introduced into the environment. Small amounts of some chemicals are capable of contaminating large volumes of water. Proper factor ratings for waste and route characteristics can adequately account for different quantities of contaminants. The fourth and last major difference is the numerical rating approach. This simplified system utilizes only an additive approach for both the factors and the characteristics to determine the final ranking. Weighting factors have been incorporated into the

rating scheme by applying sound hydrological and chemical judgment. By using an additive approach, incorporating weighting factors, and utilizing a 100-point scoring system, the users quickly develop an understanding of the sensitivity of the factors involved.

2.3 APPLICATION OF THE SIMPLIFIED HAZARDOUS SITE RANKING SYSTEM

There are three categories which comprise the evaluation of hazardous sites in the simplified hazardous site ranking system. These three categories are the source characteristics, the waste characteristics, and the route characteristics. Each category is a fraction of the total number of points. In the 100-point scoring system, the route characteristics category (surface water, groundwater, air, direct contact) is assigned the greatest importance, a maximum of 50 points. The waste characteristics category (toxicity, persistence, attenuation) is next in importance. A maximum of 35 points is allotted in this category. The last category, the source characteristics (temporal and spatial considerations), accounts for 15 points of the total score. Figure 2-1 shows the simplified hazardous ranking system developed by Geraghty & Miller, Inc. for the Potential Source Area Definition Study at Rocky Mountain Arsenal.

2.3.1 Scoring a Hazardous Site

A hazardous site can have numerous contaminants present which may migrate by any of four possible routes. The worst case scenario will be used to determine the final score for a hazardous site. It may be necessary to make several evaluations of each site for different contaminants and

SIMPLIFIED HAZARDOUS SITE RANKING SYSTEM

Site _____ Chemical _____ Section No. _____
 (Circle Factor Value Selected)

I. Source Characteristics (15 pts maximum)..... _____

A. Temporal Considerations..... _____

1. The start of contamination
 Fewer than 10 years ago (1 pt)
 Between 10 and 20 years ago (2 pts)
 Between 20 and 30 years ago (3 pts)
 More than 30 years ago (4 pts)

B. Spatial Considerations..... _____

1. Containerized (1 pt) Non-containerized (3 pts)
 2. Dispersed areally (2 pts) Concentrated areally (3 pts)
 3. Solid waste (2 pts) Liquid/gaseous waste (3 pts)
 4. Deposited below ground (2 pts) Above ground (1 pt)

II. Waste Characteristics (35 pts maximum)..... _____

	Low	Medium	High
A. Toxicity..... _____	1 pt	10 pts	20 pts
B. Persistence..... _____	2 pts	4 pts	6 pts
C. Attenuation..... _____	9 pts	5 pts	1 pt

III. Route Characteristics (50 pts maximum)..... _____
 (Evaluate all routes, select highest score)

A. Surface Water Route..... _____

1. Contemporaneous stream (0 - 50 pts)
 2. Lake/pond (0 - 50 pts)
 3. Ephemeral stream (0 - 50 pts)

B. Groundwater Route..... _____

1. Short travel time (0 - 10 yrs) (41 - 50 pts)
 2. Medium travel time (10 - 20 yrs) (31 - 40 pts)
 3. Long travel time (more than 20 yrs) (0 - 30 pts)

C. Air Route..... _____

1. Controlled release (incineration) (0 - 50 pts)
 2. Uncontrolled release (fire, dust, etc.) (0 - 50 pts)

D. Direct Contact Route..... _____ (0 - 50 pts)
 (unassociated with other routes)

TOTAL: (100 pts maximum)..... _____

FIGURE 2-1
SIMPLIFIED HAZARDOUS SITE RANKING SYSTEM
DEVELOPED BY GERAGHTY & MILLER, INC.

different routes to identify the worst case. Detailed information on evaluating hazardous sites is given in Appendix B.

2.4 GROUPING OF POTENTIAL CONTAMINATION SOURCES AT ROCKY MOUNTAIN ARSENAL

Information on potential contamination sources at Rocky Mountain Arsenal was obtained from reports, maps, and aerial photographs on file at Rocky Mountain Arsenal Information Center. Documents supplied by the U.S. Army Toxic and Hazardous Materials Agency were also consulted during the course of this study. Interviews were conducted with selected Arsenal personnel having first-hand knowledge of past and current practices at Rocky Mountain Arsenal concerning activities dealing with hazardous materials.

From the information reviewed, 32 known or suspected sites have been identified as potentially containing contaminated materials in some form. The general locations of these 32 sites are shown in Figure 2-2. The period during which the suspected activity began at each of the source areas is also given. Excluded from Figure 2-2 are the primary source areas of contamination which have been defined by previous studies.

Table 2-1 lists the 32 potential contamination sources identified at Rocky Mountain Arsenal. The site number and the Section(s) in which it occurs are given in Table 2-1 along with a brief description of the activity at each site. The 32 potential contamination sites have been divided into four different groups based on the conditions encountered.

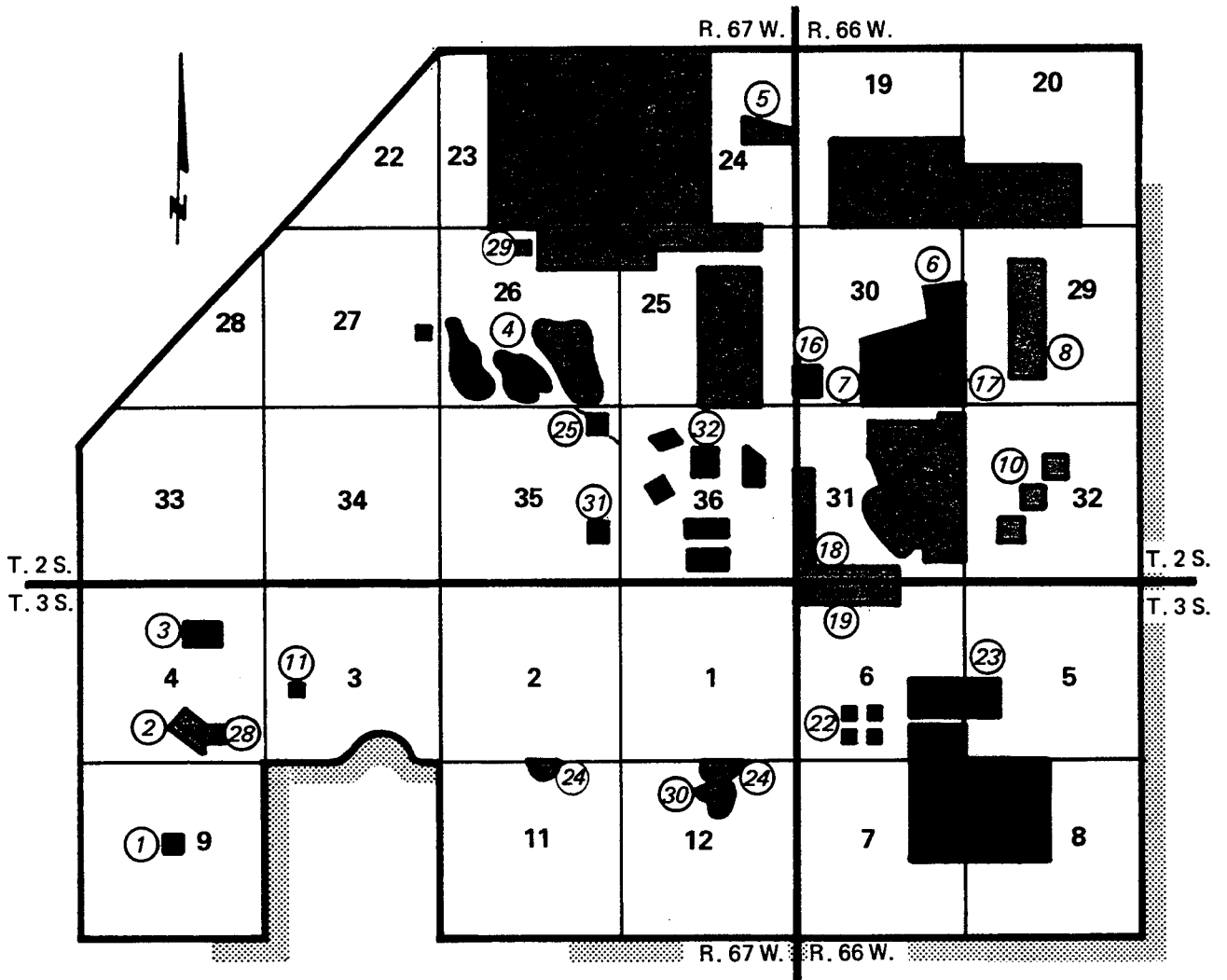

EXPLANATION

PERIOD SITE BEGAN

- 1942 - 1952
- 1952 - 1964
- 1964 - PRESENT

⑭

POTENTIAL CONTAMINATION SITES

**FIGURE 2-2
POSSIBLE SOURCE AREAS
CONTAINING CONTAMINATED MATERIAL**

**TABLE 2-1
GROUPING OF POTENTIAL CONTAMINATION SITES
IDENTIFIED IN THE POTENTIAL SOURCE AREA DEFINITION STUDY
ROCKY MOUNTAIN ARSENAL, DENVER, COLORADO**

Site No.	Section	Site Use	Group
1	9	Radio Towers	C
2	4	Sanitary Landfill	B
3	4	Disposal Trenches	B
4	26	Basins C, D, E and G	B
5	24	Disposal Pit	D
6	30	Disposal Trenches	B
7	30	Sanitary Landfill	C
8	29	Disposal Pit	D
9	31	New Toxic Storage Yard	B
10	32	Burn Pits	D
11	3	DBCP Spill in Rail Classification Yards	A
12	23, 24, 25, 26	TX Study Area	D
13	19	Surface Disposal	D
14	20	Surface Disposal	D
15	30	Impact Area	D
16	30	Mustard Training Area	C
17	30	Demilitarization Operations	C
18	31	Storage Facilities	C
19	6	Storage Facilities	C
20	6	Old Toxic Storage Yard	C
21	6	Storage Area	D
22	6	Storage Facilities	D
23	5	Outside Storage Area	C
24	11, 12	Lake Dredge Disposal Areas	B
25	35	Basin B and Connecting Ditch	B
26	25	North Plant	C
27	7, 8	Storage Area	D
28	4	Surface Disposal	D
29	26	Pumping Pit	D
30	12	Rod & Gun Club Pond	B
31	35	Caustic Basin	C
32	36	Section 36 Pits (Northeastward Migration)	B

The four groups are:

- Group A - Contamination is present and known to be migrating
- Group B - Contamination is present, but migration is unknown
- Group C - The site has received possible contamination
- Group D - Sites unlikely to have contaminants present

One site was placed in Group A, nine sites in Group B, 10 sites in Group C, and 12 sites were identified as being in Group D. The potential migration of contaminants from each site in Groups A, B, and C was evaluated to prioritize field activities to be conducted during the Phase II Technical Plan.

The data obtained from the Phase II Technical Plan was used to classify each site into one of the three categories as defined in Chapter 1 of this report. Figure 2-3 schematically illustrates how sites in the various groups are classified into one of the three categories. The data required to evaluate each site included the level and type of contamination, if present, and the rate of migration of the contaminants via several routes.

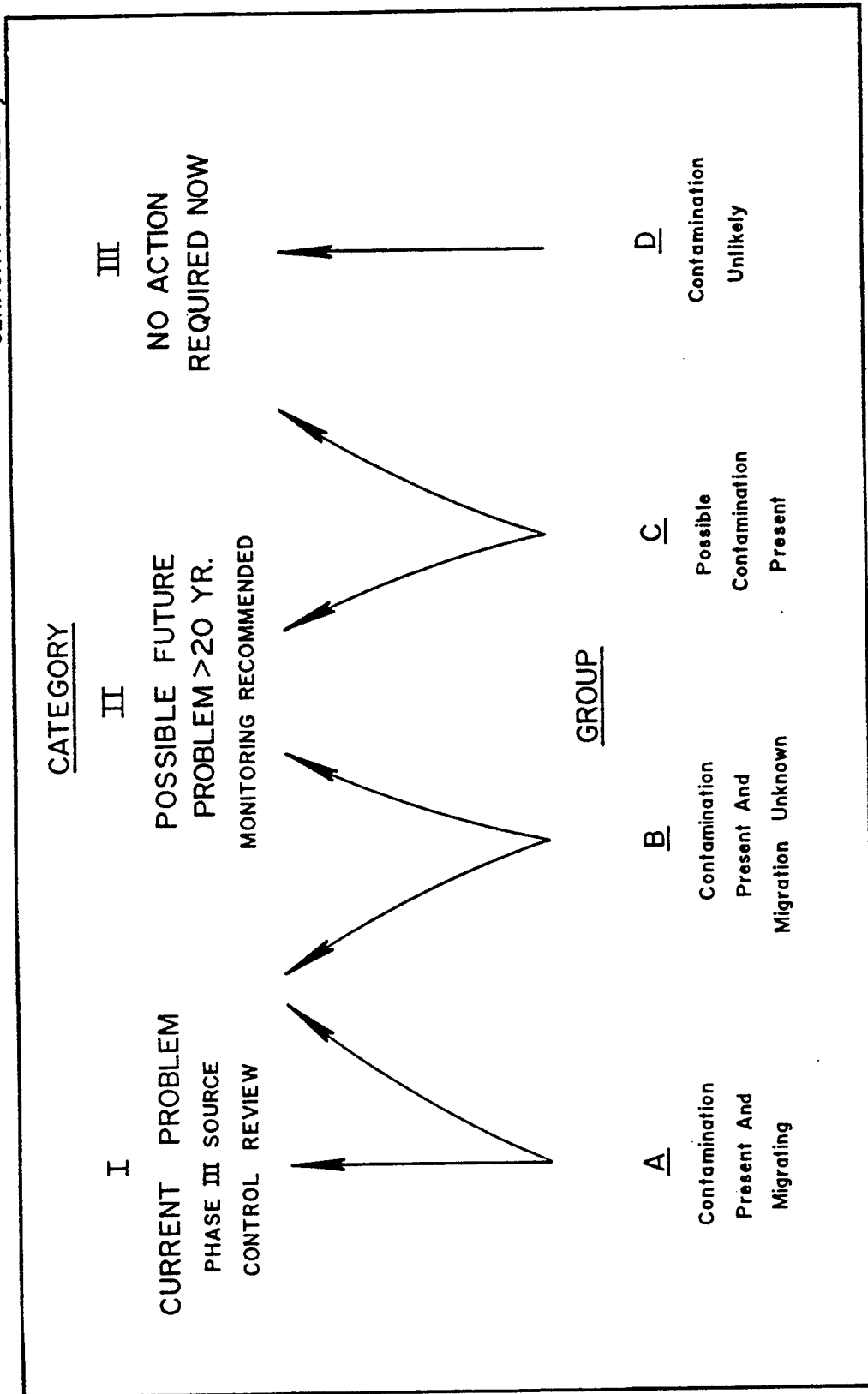

FIGURE 2-3
 CLASSIFICATION OF POTENTIAL CONTAMINATION SITES
 FROM PHASE I GROUPS TO PHASE II CATEGORIES,
 ROCKY MOUNTAIN ARSENAL, DENVER, COLORADO

CHAPTER 3

TECHNICAL PLAN

3.1 INTRODUCTION

The sampling program described in the Phase II Technical Plan was prioritized to those sites in Groups A, B, and C where contamination was known or likely to be present. The amount of geotechnical information available for various areas on Rocky Mountain Arsenal is highly variable. As future work on the Arsenal may further define the potential sources of contamination, the evaluation of the potential contamination may change. The reevaluation of sites will need to be continued as new geotechnical results are received.

3.2 IMPLEMENTATION METHODS

3.2.1 Field Activities

The field activities included the drilling and installation of two-inch diameter monitoring wells, soil sampling, surface water and groundwater sampling. Based on a review of the potential contamination sources, no geophysical effort was recommended for Phase II. Geophysical surveys would have minimal value in identifying possible contaminant migration from sources on Rocky Mountain Arsenal since the type of potential contaminants present do not lend themselves to geophysical definition. Geophysical surveys could not be expected to delineate different sources of contamination.

Two-inch diameter, PVC-cased monitoring wells were installed using a hollow-stem auger rig. Geologic samples were collected every five feet or at change in formation and placed in glass containers for transport either to the laboratory for analysis or to Rocky Mountain Arsenal for storage. The wells were developed by pumping or bailing until good communication with the aquifer was obtained. After the wells were allowed to stand for at least 48 hours, groundwater samples were taken as outlined in the Proposed Rocky Mountain Arsenal Groundwater Sampling Protocol (Stollar and Lappala, 1982) with the following exceptions. For monitoring wells where a Middleburg pump was not used for sample collection, the well bore was evacuated by bailing before a Teflon bailer was used to collect the sample. Groundwater samples were collected in appropriate containers as required by the designated parameters. Samples were cooled and transported to the laboratory daily.

Surface water samples were collected with a bailer rinsed with the water to be sampled. Untreated sample collection containers were also rinsed with the water to be sampled. Field measurements of pH and Eh (oxidation-reduction potential) were made at the time of collection for surface water and groundwater samples. These measurements were made from the discharge of the pump during groundwater sampling.

Both geologic and surface soil samples were collected. Geologic samples were taken during drilling operations with a split-spoon sampler and integrated over the length of the spoon. Surface soil samples were taken by compositing at least three subsamples within the sample site. After digging a small hole, a trowel was used to collect the subsamples

from the upper one foot of the soil. Soil samples were placed in glass containers for transport and storage.

3.2.2 Laboratory Requirements

From the review of the potential contamination sites, various agents and chemicals were identified as possibly being present at each site. Degradation products were also given for each site if known. No recommendation was made to test for any chemical or possible derivatives for which the Rocky Mountain Arsenal laboratories are not presently certified. There is no evidence that these compounds would be present given biodegradation, hydrolysis, and the time that has elapsed since the contaminants were released. Qualitative GC/MS results were supplied by the ASB.

Laboratory analysis included testing for common cations (Ca, Mg, K and Na), heavy metals (As, Cd, Cu, Fe, Mn and Hg), common anions (Cl, F, NO₃, and SO₄), and selected organic compounds. The organic compounds and inorganic constituents requested for analysis are listed in Table 3-1 along with a brief definition of each compound. The Rocky Mountain Arsenal quantitative certification method numbers describing the laboratory analysis procedures are also given in Table 3-1. Where specific chemicals could not be identified or additional information was desired, a GC/MS screen was run on samples. This identified compounds that could require further quantification during Stage II.

TAB
ORGANIC COMPOUNDS AND INORGANIC C
BY GERAGHTY

ORGANIC COMPOUNDS (Cont.)				
Compound	Formula	Scientific Name	Origin	Method Number
Aldrin	(C ₁₂ H ₈ Cl ₆)		A chlorinated hydrocarbon insecticide; intermediate in manufacturing Dieldrin; half-life is four to five years in soil.	-
BTA	(C ₇ H ₅ NS)	benzothiazole	A heterocyclic aromatic compound prevalent in manufacturing pesticide.	4P
CPMS	(C ₇ H ₇ ClS)	p-chlorophenyl-methyl sulfide	Used by Shell Chemical in manufacturing Planavin, a herbicide, between 1966 and 1975.	4P
CPMSO	(C ₇ H ₇ ClSO)	p-chlorophenyl-methyl sulfoxide	Used by Shell Chemical in manufacturing Planavin, a herbicide, between 1966 and 1975.	4P
CPMSO ₂	(C ₇ H ₇ ClSO ₂)	p-chlorophenyl-methyl sulfone	Used by Shell Chemical in manufacturing Planavin, a herbicide, between 1966 and 1975.	4P
DBCP	(C ₃ H ₅ Br ₂ Cl)	1, 2, dibromo-3 chloropropane	A chlorinated hydrocarbon manufactured by Shell Chemical as soil nematocide, Nemagon.	4Q
Dieldrin	(C ₁₂ H ₈ Cl ₆ O)		A chlorinated hydrocarbon insecticide; decomposition product of Aldrin; half-life of seven years in soil.	-
DIMP	(C ₇ H ₁₇ O ₃ P)	diisopropylmethyl-phosphonate	A byproduct in manufacturing GB (Sarin) nerve gas.	4S
DITH	(C ₄ H ₈ S ₂)	diathiane	A decomposition product in manufacturing mustard gas.	4P
Endrin	(C ₁₂ H ₈ Cl ₆ O)		A chlorinated hydrocarbon insecticide, nearly insoluble in water; half-life of four to ten years in soil.	-

10/3

**TABLE 3-1
 ORGANIC COMPOUNDS AND INORGANIC CONSTITUENTS REQUESTED FOR ANALYSIS
 BY GERAGHTY & MILLER, INC.**

		ORGANIC COMPOUNDS			
Origin	Method Number	Compound	Formula	Scientific Name	Origin
ated hydrocarbon le; intermediate ufacturing Dieldrin; s four to five oil.	—	GB (Sarin)	(F[CH ₃] ₂ CHO- POCH ₃)	Isopropyl methyl- phosphono- fluoridate	Nerve gas.
		OXAT	(C ₄ H ₈ O ₅)	1, 4 oxathiane	A decomposition product in manufacturing mustard ga
	4P				
cyclic aromatic d prevalent in uring pesticide.		INORGANIC CONSTITUENTS			
	4P	Constituent	Name	Origin	
hell Chemical in uring Planavin, le, between 1975.		As	Arsenic	Found in raw materials and byproducts of Lewisite manufacture.	
	4P	Ca	Calcium	Found in caustic processes at Rocky Mountain Arsenal.	
hell Chemical in uring Planavin, le, between 1975.		Cl	Chloride	Prevalent in salts associated with several processes at Rocky Mountain Arsenal.	
	4P	Cu	Copper	Found in waste products of pesticide manufacture.	
hell Chemical in uring Planavin, le, between 1975.		F	Fluoride	Used in the manufacturing of nerve gas.	
	4Q	Fe	Iron	Found in association with landfill leachates.	
ated hydrocarbon ured by Shell as soil nematocide,		Hg	Mercury	Used as a catalyst in Lewisite manufacture.	
		K	Potassium	See Fe.	
	—	Mn	Manganese	See Fe.	
ated hydrocarbon e; decomposition of Aldrin; half- en years in soil.		Mg	Magnesium	Residue of incendiary material.	
	4S	Na	Sodium	Found in neutralizing agents, byproducts of GB manufacture, decomposition products of GB, and various salts.	
ct in manufacturing n) nerve gas.		NO ₃	Nitrate	See Fe.	
osition product in uring mustard gas.	4P	PO ₄	Phosphate	Decomposition product of nerve gas and residue of incendiary material.	
ated hydrocarbon e, nearly in water; half- r to ten years	—	SO ₄	Sulfate	Prevalent in the salts associated with several processes at Rocky Mountain Arsenal.	

2063

TESTS REQUESTED FOR ANALYSIS
 LABORATORY, INC.

ORGANIC COMPOUNDS				
Compound	Formula	Scientific Name	Origin	Method Number
(Sarin)	(F[CH ₃] ₂ CHO- POCH ₃)	Isopropyl methyl- phosphono- fluoridate	Nerve gas.	-
AT	(C ₄ H ₈ O ₅)	1, 4 oxathiane	A decomposition product in manufacturing mustard gas.	4P
INORGANIC CONSTITUENTS				
Constituent	Name	Origin		Method Number
	Arsenic	Found in raw materials and byproducts of Lewisite manufacture.		6F
	Calcium	Found in caustic processes at Rocky Mountain Arsenal.		6G
	Chloride	Prevalent in salts associated with several processes at Rocky Mountain Arsenal.		6H
	Copper	Found in waste products of pesticide manufacture.		1M
	Fluoride	Used in the manufacturing of nerve gas.		4V
	Iron	Found in association with landfill leachates.		1M
	Mercury	Used as a catalyst in Lewisite manufacture.		1D
	Potassium	See Fe.		6G
	Manganese	See Fe.		1M
	Magnesium	Residue of incendiary material.		1M
	Sodium	Found in neutralizing agents, byproducts of GB manufacture, decomposition products of GB, and various salts.		6G
	Nitrate	See Fe.		1U
	Phosphate	Decomposition product of nerve gas and residue of incendiary material.		-
	Sulfate	Prevalent in the salts associated with several processes at Rocky Mountain Arsenal.		4U

3063

3.2.3 Laboratory Procedures

Analyzing soils chemically requires different techniques than those applicable to materials totally consumed in the process of analysis. Soils are composed of a mineral matrix with varying amounts of amorphous inorganic and organic substances intimately associated with the minerals. Metals or organic materials that may be added to soils by man's activity do not usually become part of the mineral matrix. Instead, they are held with a range of tenacity by chemical and coulombic forces on the soil particles or surfaces of amorphous coatings.

Analyzing soils for chemical substances that are not part of the mineral matrix requires the soils to be subjected to extraction with a liquid that will remove the substances with the desired degree of thoroughness. For organic substances, organic solvents, pure or mixed, are the most efficient extractants. Metals are removed with acids, chelating agents, or solutions of inorganic salts. Pure water is a less efficient extractant, but simulates rainfall percolating through soil.

Soil samples collected during this investigation were subjected to hexane and/or water extraction depending upon the objective of the individual analysis. Hexane extraction was used for estimating the amount of an organic contaminant held in the soil. Water extraction was used to estimate the total amount of contaminant that would ultimately be available for leaching to groundwater.

No extraction of soil was carried out specifically for the purpose of studying metals. The metals were analyzed in either the water or solvent extracts of the soil.

The U.S. Army Toxic and Hazardous Materials Agency Soil-Leaching Procedure with water was carried out by the S-Cubed Laboratory in California. The extracts were sent to the Rocky Mountain Arsenal ASB laboratory for analysis. Soil samples for solvent extraction were submitted to the ASB for the entire analysis. Parameters for each sample were specified on the basis of information about the contamination or residues present.

3.2.4 Data Management

The field operations conducted by Geraghty & Miller, Inc. employees were recorded in field record books or on Geraghty & Miller, Inc. geologic log forms. Locations of wells and samples were plotted on Rocky Mountain Arsenal base maps with a unique identifying designation. These temporary designations for monitoring wells were replaced as the wells were incorporated into the Rocky Mountain Arsenal and U.S. Army Toxic and Hazardous Materials Agency data base. Coordinates for sampling locations were determined from maps, while all well coordinates were surveyed by Stearns-Roger personnel.

Four types of identification were assigned for temporary designations, each of which was an alphanumeric code. The number assigned to each sample location (the numeric format was common to all four types) was composed of the Section number and sequence number within that Section. Four

different two-letter prefixes were used to identify sample types. All wells drilled by Geraghty & Miller, Inc. were denoted by GM. Geologic samples collected by the drill rig for chemical analysis were prefixed by the letters GS. Multiple geologic samples within a single well or boring were given a letter suffix with descending depth. Surface soil samples were assigned the alpha code SS while samples of surface water were given an SW prefix. Groundwater samples were labeled with a GW code followed by the Section-sequence number.

Groundwater samples from an existing well used the Rocky Mountain Arsenal designation for that well.

Geotechnical data for the U.S. Army Toxic and Hazardous Materials Agency Installation Restoration system were coded onto forms from the Rocky Mountain Arsenal Information Center. Information on location, elevation, geology, drilling, well construction, and water levels was coded onto the appropriate Sampling and Analysis file sheets: Geotechnical Map File, Geotechnical Groundwater Stabilized, or Geotechnical Field Drilling. The coding forms were submitted to the Rocky Mountain Arsenal Information Center along with the data submission logs.

The chemical analysis data was recorded from the daily laboratory reports submitted to the Soils and Geochemistry sections of the Contaminant Migration Branch at Rocky Mountain Arsenal. A summary of the GC/MS results was provided by the ASB. Chemical results were entered by the Environmental Division into the Rocky Mountain Arsenal computer system and the information will be transferred to

the U.S. Army Toxic and Hazardous Materials Agency data base after proper identifiers have been processed and verified.

3.3 TECHNICAL PLAN SUMMARY

The Technical Plan was developed to provide semiquantitative and quantitative results relative to the migration of contaminants from potential contamination sources on Rocky Mountain Arsenal. Field activities were prioritized based on the results of a preliminary evaluation of sites within each group. Details of the Technical Plan are presented in Chapter 4.

Much data from existing reports and ongoing programs were incorporated into this report. Information regarding the surface water hydrology of the Rocky Mountain Arsenal and general climatology was obtained from the Surface-Water Hydrologic Report (1982). Data received from ongoing programs were interpreted as they became available to the project team.

3.4 SAFETY PROGRAM

Prior to determining drilling locations at two potential contamination sites, the U.S. Army Tech Escort service conducted metal detector surveys. At Site 3, the survey located the limits of disposal trenches, and at Site 6, adjacent areas upgradient and downgradient of the disposal pits were selected as being acceptable for drilling (Figure 2-2). A government safety officer cleared soil samples collected at three sites where chemical agent may have been present. The soil samples from Sites 6, 20, and 33 were then

cleared of chemical agent presence by the Rocky Mountain Arsenal Environmental Assessment Laboratory prior to subjecting the soil samples to S-cubed for water extraction.

Drilling and sampling anticipated during the field investigation were conducted in areas deemed safe for the proposed activity by the U.S. Army Tech Escort support group. Appropriate safety clearances and personal health certifications were obtained by all field personnel.

**CHAPTER 4
HISTORY OF SOURCES AND
TECHNICAL PLAN RESULTS**

CHAPTER 4

HISTORY OF POTENTIAL CONTAMINATION SOURCES AND TECHNICAL PLAN RESULTS

4.1 INTRODUCTION

Significant effort was made to review the contamination sources presented in numerous reports. Attempts were made to clarify each inconsistency noted between the various reports by evaluating numerous aerial photographs and reinterviewing selected Rocky Mountain Arsenal personnel, both current and retired. At most sites, the inconsistencies have been resolved. The remaining questions concerning activities involving contaminated material will require additional study.

The information presented in this chapter gives the hydrogeological setting for each Section of Rocky Mountain Arsenal in which a potential contamination site is located. Within each Section, a site-by-site discussion of the contamination history and the associated chemical characteristics is given followed by a description of the sampling program and analytical results.

The analytical methods used by the laboratories were presented in Chapter 3. The discussions which follow deal with laboratory analysis of water samples and soil samples. Soils were extracted with either water or solvents. The analytical results given in the data tables for soil samples represent the chemical concentrations present in the soil.

4.2

BACKGROUND SOIL CHEMISTRY ON ROCKY MOUNTAIN ARSENAL

Three control soil samples were collected to help establish background soil quality. They came from areas of Rocky Mountain Arsenal where no known activities related to disposal had occurred. One sample was taken near the northeast corner of the Arsenal in Section 20, one in the southeast portion in Section 7, and the third sample was taken in the west central portion of Rocky Mountain Arsenal in Section 34. The soil samples were subjected to water extraction, a GC/MS screen and analyzed for inorganic constituents. The sample locations are shown in Figure 4-1.

Results of the chemical analysis on the control samples are presented in Table 4-1. Most inorganics occur at relatively

TABLE 4-1
RESULTS OF CHEMICAL ANALYSIS FOR CONTROL SOIL SAMPLES

Sample No.	Extract	Ca (ppm)	Cl (ppm)	F (ppm)	Fe (ppm)	K (ppm)	Mn (ppm)	Na (ppm)	SO ₄ (ppm)	Comments	
SS34-1	Water	25	BDL	3	5.2	40	.6	BDL	BDL ¹	West central	
SS20-1	Water	120	BDL	2	22.0	50	.3	BDL	BDL ¹	Northeast	
SS7-1	Water	260	BDL	2	17.0	100	4.5	BDL	BDL ¹	Southeast	
Sample No.	GC/MS Screen Compounds Detected							Comments			
SS34-1	Fragmented ring compounds, carotenoids or long-chain compounds, e.g. oils, phthalates							Carotene-like compounds are probably algal pigments			
SS20-1	Cyclohexanone, trace tetrachloroethylene, diethyl phthalate, carotene-like substance										
SS7-1	Long-chain hydrocarbon compound*, e.g. oils or fragmented ring compounds, CPMSO ₂ , phthalates										

NOTE: BDL - Below Detectable Level of 20 ppm.
BDL¹ - Below Detectable Level of 50 ppm.

* Long-chain hydrocarbons occur naturally in soils.

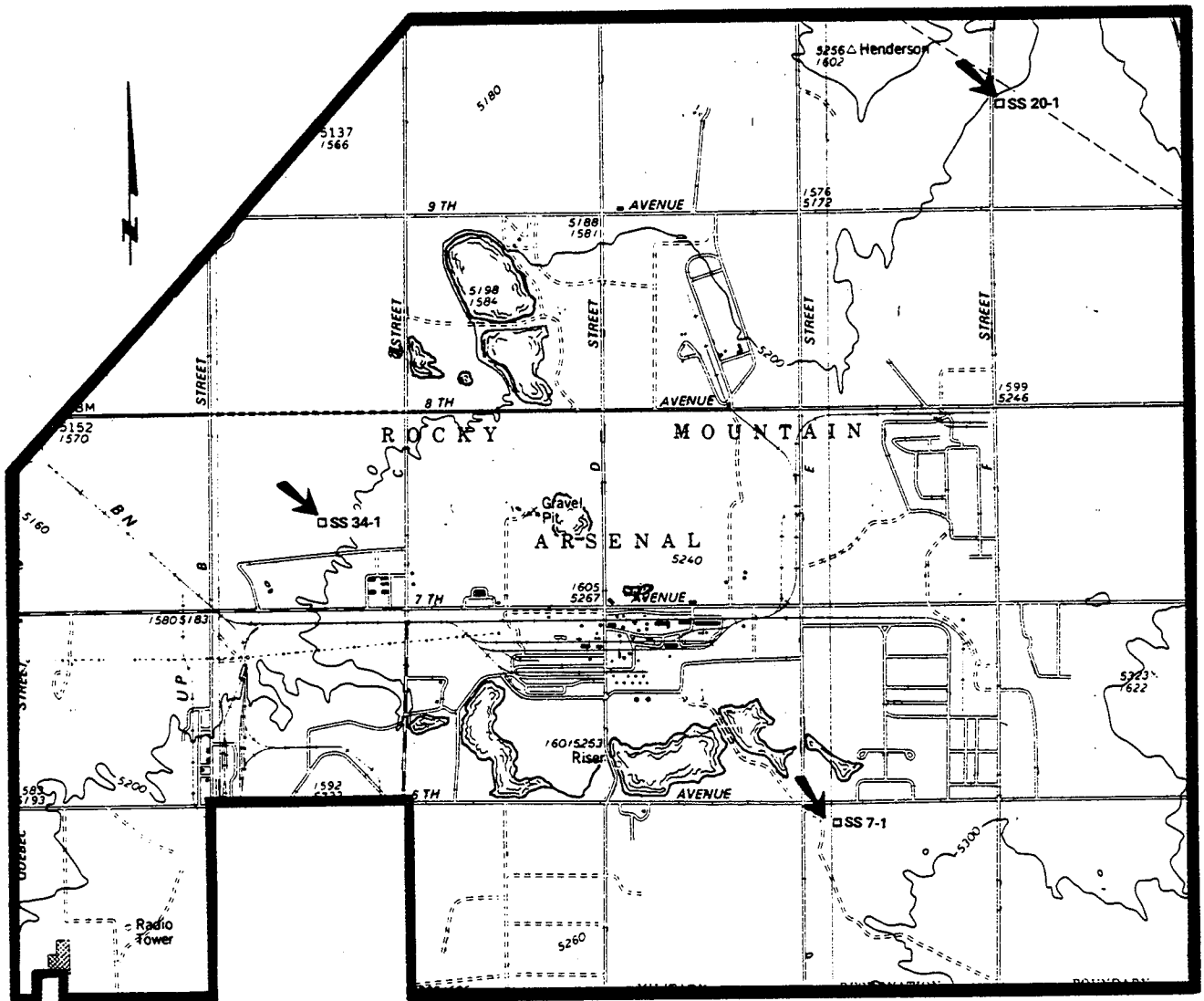

FIGURE 4-1
 LOCATION OF CONTROL SOIL SAMPLES
 ROCKY MOUNTAIN ARSENAL, DENVER, COLORADO

low levels in soils on Rocky Mountain Arsenal, with chloride, sodium, and sulfates being below detectable levels. Long-chain hydrocarbon compounds and phthalates were detected in soil samples from Sections 34 and 7. The Section 7 sample also contained CPMSO₂. The soil sample from Section 20 contained some cyclohexanone, diethyl phthalate, a carotene-like substance, and a trace of tetrachloroethylene.

Low concentrations of various organic compounds can likely be detected throughout the shallow soils on Rocky Mountain Arsenal. Several activities in the Arsenal's history, such as the enhanced spray operation on Basin F and incineration of materials, as well as normal wind and dust dispersion of contaminants, combined to distribute the compounds over Rocky Mountain Arsenal.

Information on concentrations of selected chemicals in the soils has been reported in several previous studies. Foremost among these are the "Report on OTSG Coring Data for Compounds at Rocky Mountain Arsenal" (Cogley, 1976) and "Contaminant Leaching Investigation at Rocky Mountain Arsenal" (Wullschleger, et al, 1981).

Cogley developed approximate background levels of 15 selected chemicals and compounds, six of which are of interest to this study, by analyzing core samples drilled in Sections 5, 6, 8, and 9 in the southeast corner of Rocky Mountain Arsenal. Fifteen core samples were collected in the upper two feet of soil borings and fifteen samples were collected from two to seven feet deep. Ten samples each were taken between the 7 and 12 foot depth and the 12 to 17 foot depth. Six core

samples were taken between 17 and 22 feet.

The background concentrations of eleven chemicals and compounds, including Aldrin, Dieldrin, and Endrin were zero. The background level for arsenic was estimated to be 0.2 parts per million (ppm), for copper 7.0 ppm, for mercury 0.6 ppm, and for zinc 35 ppm.

Background levels in uncontaminated soil on Rocky Mountain Arsenal were also determined in an investigation on contaminants leaching through soils (Wullschleger, et al, 1981). Background soil samples collected in a soil boring in Section 7 contained no measurable amount of DBCP, DIMP, or Endrin. Chloride was present at an average concentration of 283 ppm in the upper one foot of soil while the background arsenic level was 2.65 ppm in the upper foot of uncontaminated soil.

4.3 EVALUATION OF SECTION 26

Located in the northwest portion of Rocky Mountain Arsenal, Section 26 contains one potential contamination site (Basins C, D, E and G) which is shown in Figure 4-2. Basin F is considered a primary source and is not included in this study. The unconsolidated sediments underlying Section 26 are approximately 30 feet thick. The depth to water varies from 25 to 30 feet and the water table may lie in the Denver formation in some areas. Water table contours indicate groundwater flow is predominantly northwesterly in the southern part of the Section, while groundwater flow is more northerly in the northern portion of the Section.

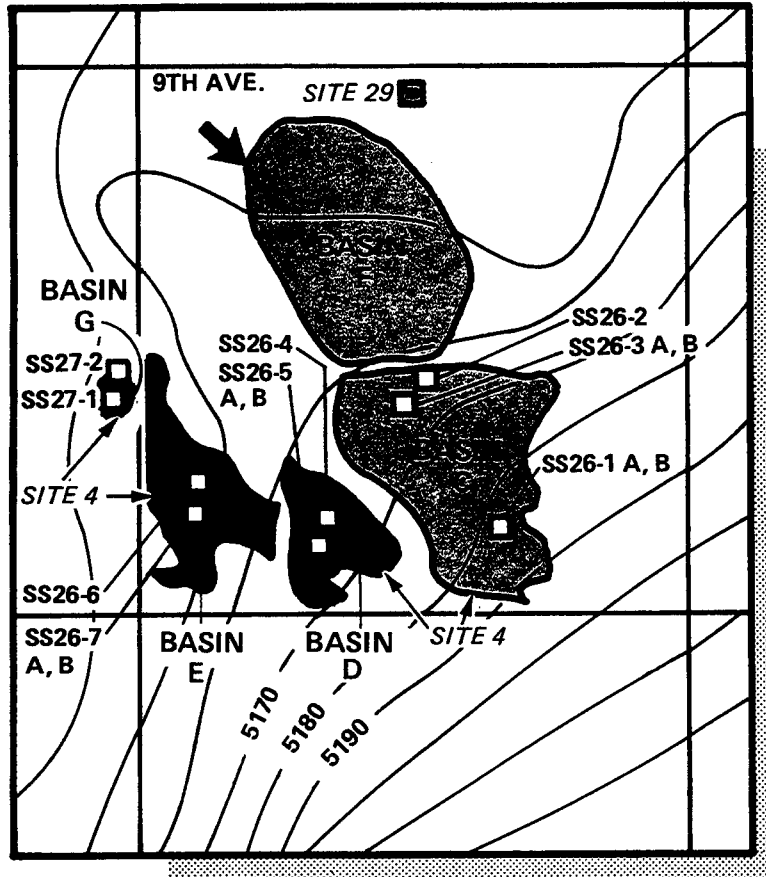

- EXPLANATION**
- | | |
|--|-----------------------------|
| PERIOD SITE BEGAN | SAMPLE TYPE |
| ■ 1942 - 1952 | □ SS - SOIL SAMPLE |
| ■ 1952 - 1964 | ○ - MONITORING WELL |
| ■ 1964 - PRESENT | ▲ SW - SURFACE WATER SAMPLE |
| ~ 5190 ~ GROUNDWATER CONTOUR | ⬡ GS - GEOLOGIC SAMPLE |
| ➔ AREA NOT ADDRESSED IN TECHNICAL PLAN | |

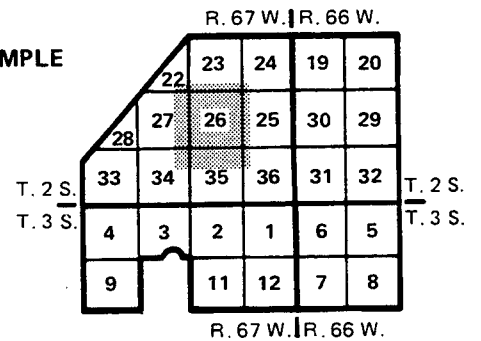

FIGURE 4-2
POTENTIAL CONTAMINATION SOURCES IN SECTION 26,
ROCKY MOUNTAIN ARSENAL, DENVER, COLORADO

4.3.1 Site 4. Basins C, D, E, and G

Site 4 includes Basins C, D, E and G which are shown in Figure 4-1. Basin C received discharges from the North Plant, large quantities of fresh water from Sand Creek Lateral, and also temporarily held liquid wastes while Basin F underwent lining repairs. Basins D, E, and possibly G received overflow from Basin A and discharge from the chlorine plant during the 1940's (Jones, et al, 1977). These four basins overlie several contamination plumes originating in the Basin A area. Basins D and E were used during the 1940's (see 1948 aerial photograph) and Basin C was constructed in 1953 after operations began at the North Plant. No overflow is apparent today from Basin E to Basin G.

Both organic and inorganic chemicals have been disposed of in the basins in Section 26 as were several heavy metals which were used in the synthesis of chemical agents and explosives or used as catalysts. These metals include mercury, lead, arsenic and possibly others. Sulfur- and nitrogen-containing compounds from chemical agents and reagents used in various processes have also been deposited in the basins.

Thirteen soil samples were collected at Site 4 at depths of up to three feet. The soil samples were subjected to either solvent extraction or water extraction for analysis of DBCP, DIMP, OXAT, DITH, CPMS, CPMSO, CPMSO₂, copper and arsenic. Five samples were collected from Basin C, three samples each from Basins D and E, and two samples from Basin G. No layering of windblown or water-borne sediments was apparent in any of the basins.

Results of the chemical analysis of samples collected at Site 4 are given in Table 4-2. The solvent-extracted samples from Basin C contained less than 1 ppm of DIMP, CPMS, and CPMSO at both the zero to one foot depth and the two to three foot depth. The shallow soil sample contained 4.08 ppm of CPMSO₂. No contaminants were detected in the water-extracted samples from Basin C. Less than 0.001 ppm of DIMP and 0.1 ppm of CPMSO₂ was found in the solvent extracts from Basin D samples, with no report of contamination in the water extracts. The solvent extract results for Basin E were similar to those in Basin D, but the shallow soil sample contained 0.48 ppm of CPMSO in the water extract. No detectable contamination was found in the samples from Basin G.

**TABLE 4-2
RESULTS OF CHEMICAL ANALYSIS FOR SITE 4**

Sample No.	Extract	DBCP (ppm)	DIMP (ppm)	OXAT (ppm)	DITH (ppm)	CPMS (ppm)	CPMSO (ppm)	CPMSO ₂ (ppm)	As (ppm)	Cu (ppm)	Comments
SS26-1A	Water	BDL	BDL	BDL	BDL	BDL	BDL	BDL	BDL	BDL	Basin C
SS26-1B	Solvent	ND	.87	BDL	BDL	BDL	BDL	BDL	10.0	4.8	Basin C
SS26-2	Water	BDL	BDL	BDL	BDL	BDL	BDL	BDL	BDL	2.9	Basin C
SS26-3A	Solvent	ND	.0005	BDL	BDL	.12	.34	4.08	BDL	6.2	Basin C
SS26-3B	Solvent	ND	0.2	BDL	BDL	BDL	BDL	BDL	3.0	2.9	Basin C
SS26-4	Water	BDL	BDL	BDL	BDL	BDL	BDL	BDL	BDL	BDL	Basin D
SS26-5A	Solvent	ND	BDL	BDL	BDL	BDL	BDL	.05	.0079	0.01	Basin D
SS26-5B	Solvent	ND	0.1	BDL	BDL	BDL	BDL	BDL	4.0	1.1	Basin D
SS26-6	Water	BDL	BDL	BDL	BDL	BDL	0.481	BDL	BDL	BDL	Basin E
SS26-7A	Solvent	ND	—	BDL	BDL	BDL	BDL	0.5	.0024	.0062	Basin E
SS26-7B	Solvent	ND	0.05	BDL	BDL	BDL	BDL	BDL	2.6	7.1	Basin E
SS27-1	Water	BDL	BDL	BDL	BDL	BDL	BDL	BDL	BDL	BDL	Basin G
SS27-2	Solvent	ND	BDL	BDL	BDL	BDL	BDL	BDL	BDL	1.8	Basin G

NOTE: BDL - Below Detectable Level
ND - Not Detectable

	Detectable Levels (ppm)	
	Water	Solvent
DBCP	.002	—
DIMP	0.1	.0002
OXAT	0.2	.07
DITH	0.2	.06
CPMS	0.2	.10
CPMSO	0.2	.14
CPMSO ₂	0.2	.04
As	0.5	1.3
Cu	0.4	0.8

Arsenic and copper were selected for analysis in the soil samples because they represented inorganic components of materials deposited in the basins. The highest level measured was 7.1 ppm of copper in Basin E, compared to the background level of 7 ppm. The highest arsenic concentration was 10 ppm, found at the two to three foot sample depth in Basin C. This was approximately four times the highest background level previously reported.

The shallow soil sampling done in Basins C, D, and E resulted in finding traces of several organic compounds. DIMP is the only one for which there is a water concentration standard set at 0.5 ppm. The highest soil concentration was 0.87 ppm as determined with solvent extraction. This concentration in soil is not deemed to be sufficiently high to pose a threat to the groundwater standard. Groundwater samples collected in 1979 and 1980 upgradient and downgradient of Site 4 contained DIMP at levels between 0.13 ppm and 2.5 ppm. Thus, the soil does not represent significant source quantities of DIMP. The water samples contained 0.36 ppm of CPMSO, so a potential does exist for CPMSO to be leached from Basin E if the results of the soil samples are representative of Basin E.

Arsenic and copper should be strongly associated with soil and would not quantitatively dissociate into the water phase. Therefore, the concentrations found in the soil should pose no problem to groundwater degradation.

The shallow soils in Basin C appear to have been leached of most organic contaminants by the large quantities of fresh water discharged into the basin. Basin G sample results

indicate no significant contamination, so it is questionable whether Basin G ever received much contaminated material. Basins D and E are believed to be the two most likely basins to have residual organic contamination having the potential to migrate. Continued sampling of monitoring wells in this area is recommended to determine if further degradation of the groundwater quality occurs.

4.4 EVALUATION OF SECTION 35

Two potential contamination sources, located in Section 35 in the central portion of Rocky Mountain Arsenal, are shown in Figure 4-3. The thickness of the alluvium varies from zero to approximately 35 feet. Depth to water is about 15 feet in the northeastern part of Section 35. Water table contours indicate groundwater flow is from southeast to northwest throughout the Section.

4.4.1 Site 25. Basin B and Connecting Ditch

The ditch connecting Basin A to Basin B and Basin B to Basins D and E was first in use in the early 1940's. Chemicals present in Basin A or transported by Sand Creek Lateral from the South Plants area may also be present in this ditch and Basin B. Animal deaths have been reported over the years in this area (Jones, et al, 1977). This area overlies several contamination plumes originating in the Basin A area.

Four soil samples were collected at Site 25--two from the drainage ditch, above and below Basin B, and two samples within Basin B. One sample from Basin B was extracted with

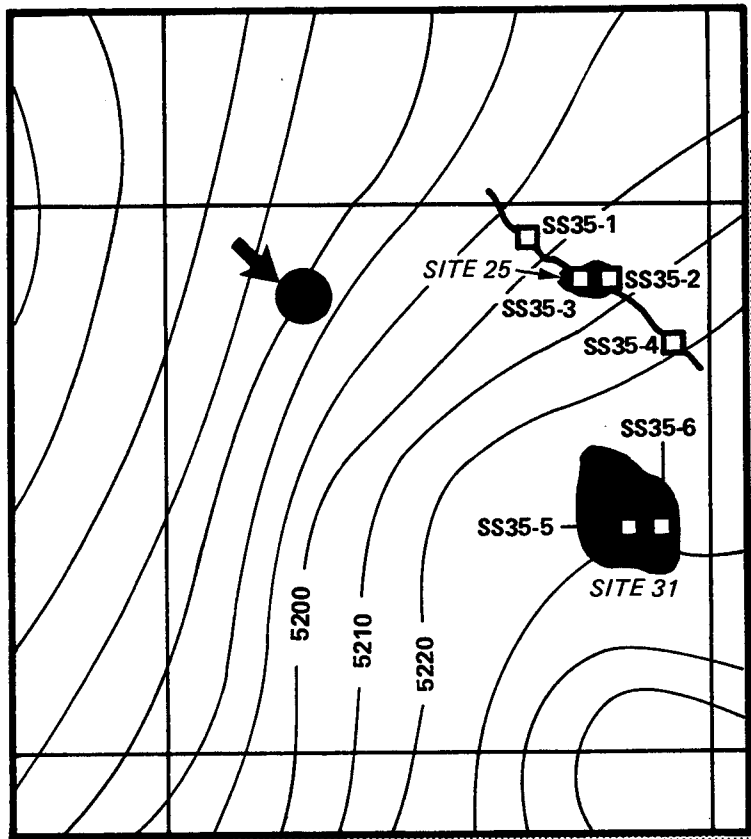

EXPLANATION

PERIOD SITE BEGAN

- 1942 - 1952
- 1952 - 1964
- 1964 - PRESENT

5190 GROUNDWATER CONTOUR

AREA NOT ADDRESSED IN TECHNICAL PLAN

SAMPLE TYPE

- SS - SOIL SAMPLE
- MONITORING WELL
- SW - SURFACE WATER SAMPLE
- GS - GEOLOGIC SAMPLE

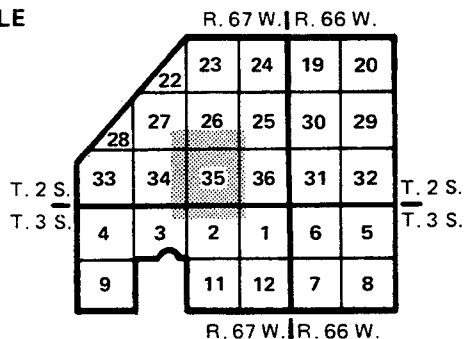

**FIGURE 4-3
POTENTIAL CONTAMINATION SOURCES IN SECTION 35,
ROCKY MOUNTAIN ARSENAL, DENVER, COLORADO**

solvent and the other three samples were extracted with water. The samples were tested for DBCP, DIMP, OXAT, DITH, CPMS, CPMSO, CPMSO₂, copper, and arsenic.

Results of the chemical analysis of the samples collected are given in Table 4-3. The organic analysis showed 0.05 ppm of CPMSO₂ in the solvent-extracted sample from Basin B. CPMSO₂ is not considered to be significant in its ability to partition out into water. No arsenic or copper was found in the soil samples.

**TABLE 4-3
RESULTS OF CHEMICAL ANALYSIS FOR SITE 25**

Sample No.	Extract	DBCP (ppm)	DIMP (ppm)	OXAT (ppm)	DITH (ppm)	CPMS (ppm)	CPMSO (ppm)	CPMSO ₂ (ppm)	As (ppm)	Cu (ppm)	Comments
SS35-1	Water	BDL	BDL	BDL	BDL	BDL	BDL	BDL	BDL	BDL	Ditch
SS35-2	Solvent	ND	—	BDL	BDL	BDL	BDL	.05	BDL	BDL	Basin B
SS35-3	Water	BDL	BDL	BDL	BDL	BDL	BDL	BDL	BDL	BDL	Basin B
SS35-4	Water	BDL	BDL	BDL	BDL	BDL	BDL	BDL	BDL	BDL	Ditch

	Detectable Levels (ppm)	
	Water	Solvent
DBCP	.002	—
DIMP	0.1	.0002
OXAT	0.2	.07
DITH	0.2	.06
CPMS	0.2	.10
CPMSO	0.2	.14
CPMSO ₂	0.2	.04
As	0.5	1.3
Cu	0.4	0.8

NOTE: BDL - Below Detectable Level
ND - Not Detectable

The analytical results from Basin B and the connecting ditch show no significant concentrations of organic or inorganic substances. There appears to be no potential threat for migration of contaminants from Site 25 of compounds in the shallow soils at this site.

4.4.2 Site 31. Caustic Basin

The caustic basin in the east central part of Section 35 was constructed in 1942. Liquid wastes from the chlorine plant were to have been discharged into this basin. Caustic resulting from production was actually used on Rocky Mountain Arsenal or sold, but apparently not deposited in the basin (Donnelly, personal communication, 1982). Aerial photographs do not show significant quantities of liquid in this basin at any time.

Liquid slurry may have contained calcium, magnesium, sodium carbonates, bicarbonates, and some hydroxide salts. These salts are not toxic, but would add to the hardness and mineral content of water.

Two soil samples were collected from the caustic basin and analyzed for calcium, chloride, sodium, sulfate, and hardness. Both soil samples were leached with water because the compounds are water soluble.

Results of chemical analysis of the samples taken at Site 31 are given in Table 4-4. Neither sample contained detectable concentrations of chloride, sodium, or sulfate. One sample contained 560 ppm of calcium while the other sample had 31 ppm. The level of 560 ppm of calcium is above levels found in control soil samples, but it is believed to have resulted from the evaporation of surface water runoff and not from the disposal of caustic material.

Reports that little or no caustic material was discharged to

**TABLE 4-4
RESULTS OF CHEMICAL ANALYSIS FOR SITE 31**

Sample No.	Extract	Ca (ppm)	Cl (ppm)	Na (ppm)	SO ₄ (ppm)	Comments
SS35-5	Water	31	BDL	BDL	BDL ¹	Caustic Basin
SS35-6	Water	560	BDL	BDL	BDL ¹	Caustic Basin

NOTE: BDL - Below Detectable Level of 200 ppm.
BDL¹ - Below Detectable Level of 500 ppm.

this basin are supported by the analytical results. This basin is not regarded as a potential source for the migration of contaminants.

4.4.3 Sites Not Addressed by Technical Plan

Review of aerial photographs since the approval of the Technical Plan in Phase I has indicated an area in the northwest corner of Section 35 (Figure 4-3), which apparently was the launching area for testing long-range mortars during the late 1940's (Jones, et al, 1977). No migration of contaminants would be expected from this area.

4.5 EVALUATION OF SECTION 25

Shown in Figure 4-4, Section 25 has one potential contamination source area. This Section is in the north central portion of Rocky Mountain Arsenal. The alluvium thickness varies from 10 feet near First Creek to a maximum of 40 feet. A bedrock high occurs in the Basin A neck area. Depth to water varies from 10 feet along First Creek to about 60 feet below the bedrock high area. The water table lies in the Denver formation except near E Street and First Creek. The water table contours show a groundwater mound in the Basin A neck area in the south central portion of the

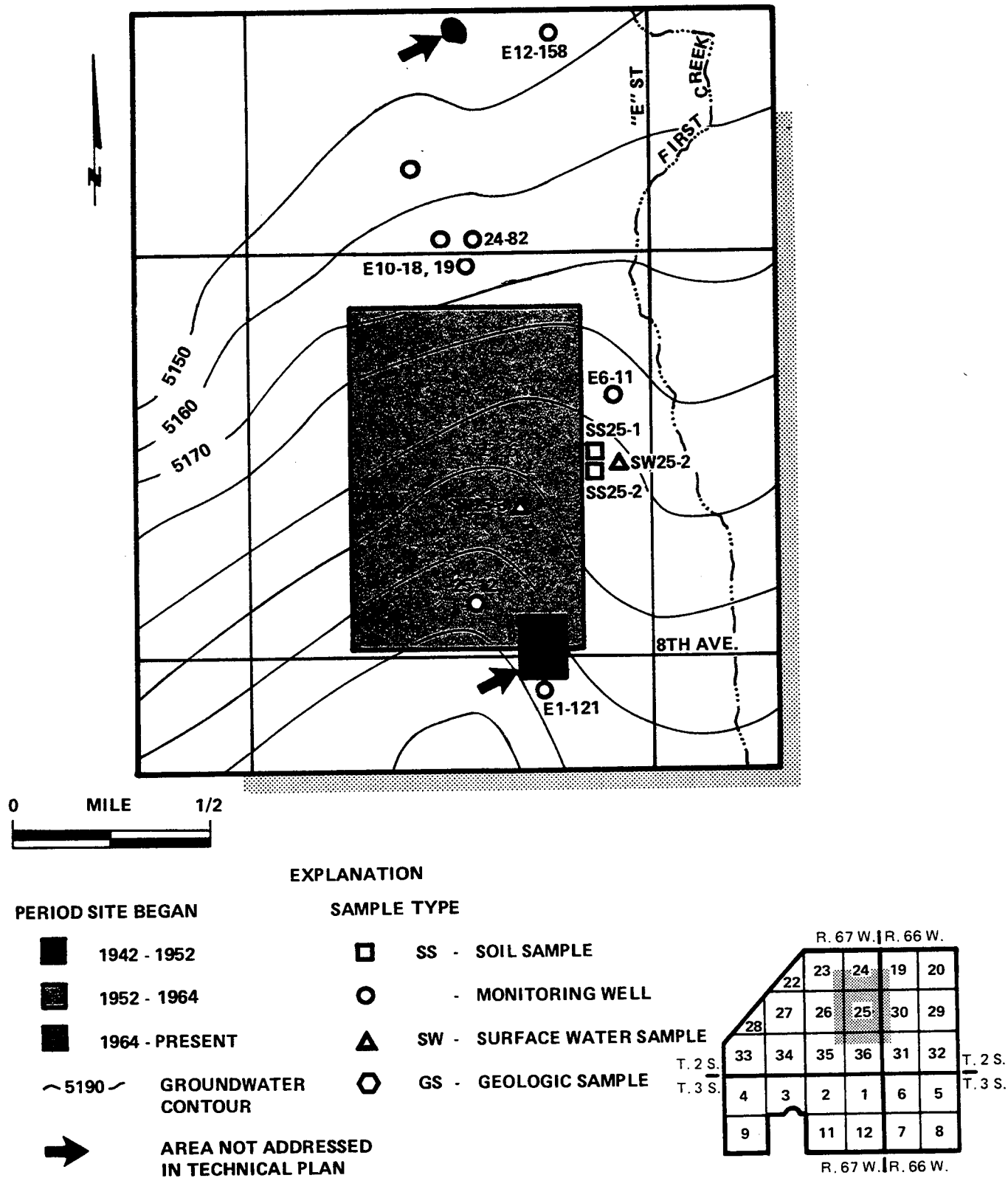

FIGURE 4-4
POTENTIAL CONTAMINATION SOURCES IN SECTION 25,
ROCKY MOUNTAIN ARSENAL, DENVER, COLORADO

Section. Groundwater flow radiates outward from the mound in a northerly direction.

4.5.1 Site 26. North Plant

The outfall from the North Plant storm sewer system flows into a tributary of First Creek. It was reported that previous sampling indicated the possibility of contamination near the outfall (Berry, personal communication, 1982).

Two sediment samples and one surface water sample were collected in the tributary receiving the outfall's discharge. The three samples were subjected to GC/MS screening to detect organic compounds. In addition, the groundwater quality in three regional wells was reviewed for possible contamination. Four additional Rocky Mountain Arsenal wells were sampled for DIMP, as was a surface drain sump near Building 1703.

Table 4-5 gives the results of sampling at Site 26. The surface water sample in the tributary indicated no contamination while the sump contained 0.0074 ppm of DIMP. The two soil samples did contain some organic compounds: cyclohexanol, nitrogen compound, possible di t-butyl 3,3 dimethyl, bicyclo- (3.1.0) hexane-2-one, diethyl and dibutyl phthalates, possible diisopropyl ethyl phosphate, carotene-like substance and possible trinorbutyl-amine. The phthalates and carotene-like substances were also present in control soil samples (Table 2-2) taken within Rocky Mountain Arsenal boundaries.

**TABLE 4-5
RESULTS OF CHEMICAL ANALYSIS FOR SITE 26**

Sample No.	GC/MS Screen Compounds Detected					Comments
SS25-1	Cyclohexanol, nitrogen compound, (incomplete spectra), possible di t-butyl 3,3 dimethyl bicyclo- (3.1.0) hexane-2-one, diethyl & dibutyl phthalates, possible diisopropyl ethyl phosphate					Carotene-like compounds are probably algal pigments
SS25-2	Possible tri-norbutyl-amine					
SW25-2	Carotene-like substance					
Regional Well	BTA (ppm)	CPMSO (ppm)	CPMSO ₂ (ppm)	DITH (ppm)	DIMP (ppm)	Comments
E1-121	BDL	BDL	BDL	BDL	BDL	Upgradient
E10-18	BDL	BDL	BDL	BDL	.274	Downgradient
E10-19	BDL	BDL	BDL	BDL	.0125	Downgradient
E6-11	BDL	BDL	BDL	BDL	BDL	Downgradient
24-81	-	-	-	-	.256	Downgradient
24-82	-	-	-	-	.256	Downgradient
24-111	-	-	-	-	.292	Downgradient
25-12	-	-	-	-	.0373	Upgradient
SW25-3	-	-	-	-	.0074	Sump

NOTE: BDL - Below Detectable Level of 0.02 ppm.

No organic compounds were detected in the upgradient regional well E1-121, or in well E6-11 downgradient to the northeast of the outfall. However, DIMP was found at a level of 0.274 ppm in regional well E10-18 north of the North Plant. This well is screened in the alluvium. Well E10-19, screened in the upper Denver formation, contained 0.0125 ppm of DIMP.

The three Rocky Mountain Arsenal wells in Section 24 had DIMP levels between 0.256 ppm and 0.292 ppm. Well 25-12 in Section 25, located in the southern portion of the plant area, had a DIMP level of .0373 ppm. All of the DIMP concentrations measured are below the Colorado standard of 0.5 ppm.

In summary, the surface water sample at the outfall does not indicate the presence of any contaminants originating from the North Plants outfall. The qualitative GC/MS screening on the two soil samples did indicate the presence of some organic compounds. Additional testing will be required in order to quantify the level of contamination present in the soils near the outfall. The appearance of DIMP in wells north of the plants area indicates the migration of DIMP either originating within the North Plant boundary or leaking from the sanitary sewer serving the North Plant. A groundwater sample also indicates the possibility that low-level DIMP contamination may also be present in the upper Denver formation as well as the alluvium, but this needs to be confirmed. The presence of DIMP north of the plant area was indicated in a previous report (Stollar and van der Leeden, 1981), but the actual source area and the extent and rate of migration need additional study.

4.5.2 Sites Not Addressed by Technical Plan

An area undefined in previous reports was identified on the 1949 aerial photograph near the southeast corner of the North Plant boundary. It has been reported that this was the area used for testing napalm bombs (Buxton, personal communication, 1982).

4.6 EVALUATION OF SECTION 30

Section 30, in the northeast corner of Rocky Mountain Arsenal, contains four sites evaluated by the Technical Plan plus several sites not evaluated. The location of the potential contamination sites are shown in Figure 4-5. The

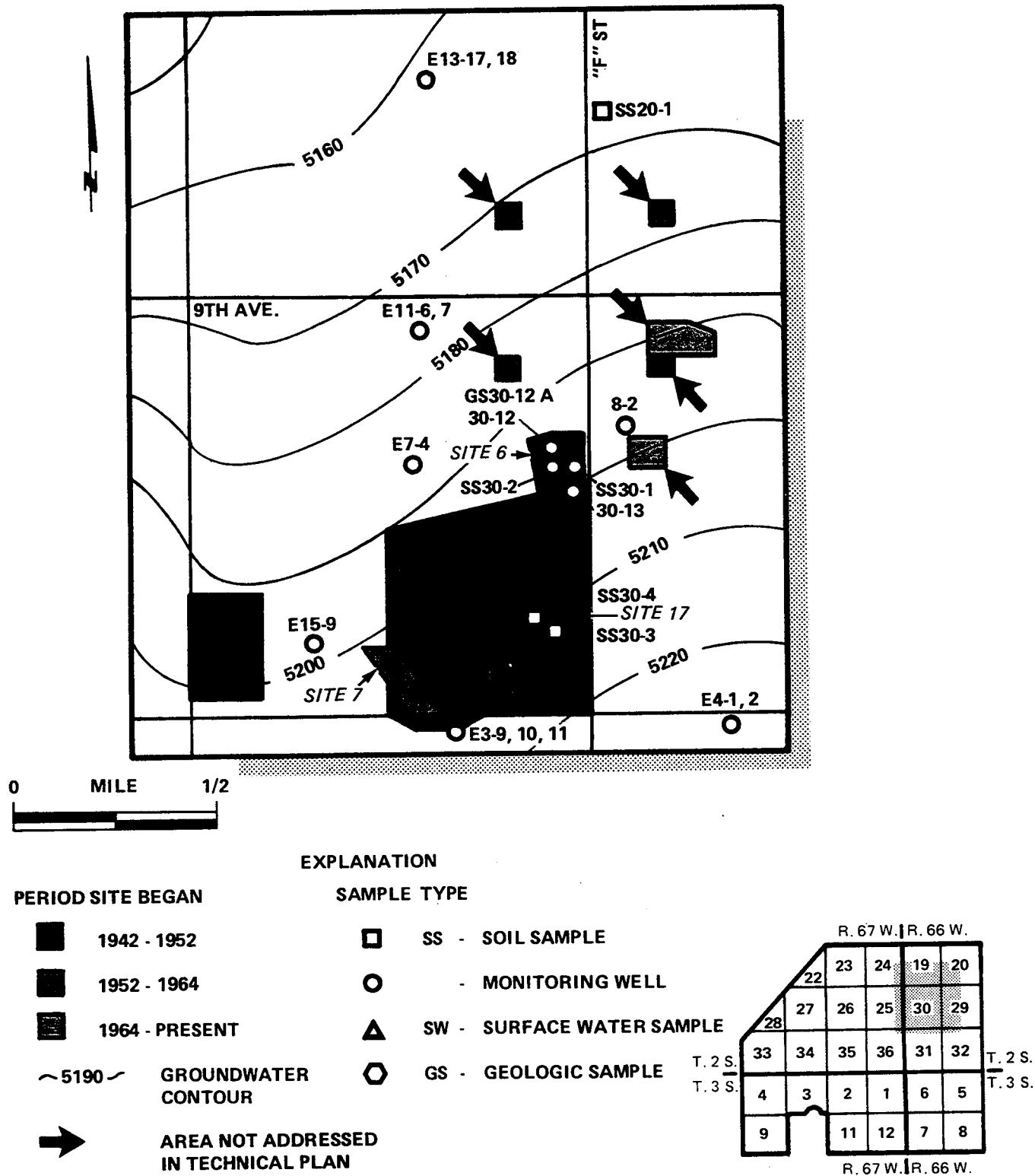

FIGURE 4-5
POTENTIAL CONTAMINATION SOURCES IN SECTION 30,
ROCKY MOUNTAIN ARSENAL, DENVER, COLORADO

thickness of the alluvium in Section 30 varies from a few feet to a maximum of 20 feet. The thickest alluvial deposits are found along First Creek in the vicinity of well E15. Section 30 overlies a bedrock high and the alluvium is unsaturated except for an area along First Creek. Depth to water varies from a few feet to about 40 feet. The water table is in the Denver formation under most of the Section. The direction of groundwater flow is generally to the northwest, but in the northwest corner of the Section groundwater contours indicate northward flow.

4.6.1 Site 6. Disposal Trenches

Site 6 was reportedly used as a disposal area for liquid from M-34 GB clusters from 1954 to 1955 (Jones, et al, 1977). No documented report has been found to substantiate this. The trenches at Site 6 have also been used for the disposal of rocket motors, squibs, and fuses (Jones, et al, 1977).

The hydrolysis of any GB liquid reportedly disposed of at this site would have led to the formation of isopropyl methylphosphonate. The GB liquid also contained some diisopropyl methylphosphonate. It is likely that the period of time since any chemical agent was released is sufficient to have allowed hydrolysis of the GB and the dispersion of the contaminants.

Two groundwater monitoring wells were drilled at Site 6, one upgradient and one downgradient. Groundwater samples were collected from both wells. One geologic sample was taken from the downgradient well, and a soil sample was taken in

each of two open trenches. A GC/MS screen was run on all samples for organic derivatives of agents.

No compounds were detected in either of the two soil samples taken in the trenches between zero and one foot deep as reported in Table 4-6. The geologic sample, taken in the downgradient well at a depth of 45 to 46 feet below land surface, indicated the presence of some DIMP, hydrocarbons, and phthalates. The groundwater sample from this monitoring well indicated some long-chain fragments of oils, some phthalates and some carotene-like compounds. No DIMP was detected in the groundwater sample. The upgradient groundwater sample also contained phthalates and some fragmented ring compounds.

**TABLE 4-6
RESULTS OF CHEMICAL ANALYSIS FOR SITE 6**

Sample No.	GC/MS Screen Compounds Detected					Comments
GS30-12A SS30-1 SS30-2	DIMP, hydrocarbons, phthalates None None					Negative chemical agent tests Negative chemical agent tests
30-12	Long-chain fragments of oils or the like, * phthalates, carotene-like compounds.					See Table 3
30-13	Fragmented ring compounds, phthalates					
Regional Well	Ca (ppm)	Cl (ppm)	K (ppm)	Na (ppm)	SO ₄ (ppm)	Comments
E4-1	102	91	8.1	237	480	Upgradient
E4-2	82	86	4.0	289	560	Upgradient
E11-6	350	455	10.1	1930	4200	Downgradient
E11-7	70	115	5.0	310	980	Downgradient
E13-17	70	50	9.5	145	300	Downgradient
E13-18	91	33	5.0	476	1220	Downgradient

NOTE: BTA, CPMSO, CPMSO₂, and DITH measured below detectable levels of 0.2 ppm in regional well samples

* Long-chain hydrocarbons occur naturally in soils.

Water quality results from several regional wells were also reviewed for changes in the groundwater. The quality of water from well E4-1, about one-half mile upgradient of Site 6, is significantly better than the water quality from well Ell-6, about one-half mile downgradient. The water from well Ell-6 is much more mineralized than water from well E4-1. Calcium, chloride, sodium, and sulfate concentrations in well Ell-6 all exceed the concentrations in well E4-1 by three to nearly tenfold. This degradation in water quality is probably a result of the screen in well 11-6 being located in a lignite or coal zone.

No migration of contaminants from Site 6 was detected in the sampling program. The presence of DIMP in the geologic sample was not observed in the groundwater sample.

Groundwater level measurements on the new monitoring wells were several feet higher than expected based on previous groundwater contour maps. The effect of this difference is to shift the direction of groundwater flow more to the west, but this change does not appear to be significant enough to have resulted in missing possible contaminants downgradient from Site 6.

4.6.2 Site 7. Sanitary Landfill

The sanitary landfill, located in the south central portion of Section 30, was established in the late 1960's or early 1970's and is still in use today. Typical landfill leachates were expected at this site. Sodium, calcium, bicarbonate, chloride, and iron would likely be found in concentrations above background levels. The organic material coming from

this source would likely be the decomposition products of the garbage-type wastes deposited in the landfill.

No field sampling was conducted at Site 7, but the water quality results from two regional wells were reviewed and are given in Table 4-7. The water quality in each well was similar, showing no increase in chloride or calcium concentrations which usually result from landfill leaching. It appears from a review of the regional well data that Site 7 is having no discernable effect on the groundwater quality in this area.

**TABLE 4-7
RESULTS OF CHEMICAL ANALYSIS FOR SITE 7**

Regional Well	Ca (ppm)	Cl (ppm)	Fe (ppm)	K (ppm)	Mn (ppm)	Na (ppm)	NO ₃ (ppm)	SO ₄ (ppm)	Hardness (ppm)	Comments
E15-9	84	83	-	5.9	-	196	-	480	-	Downgradient
E3-9	88	119	-	6.7	-	195	-	290	-	Upgradient

4.6.3 Site 16. Mustard Training Area

No documented reports concerning the training activities involving mustard have been found. However, it was reported that exercises in this area involved contaminating a parked aircraft with mustard and having troops decontaminate it (Donnelly, personal communication, 1982). The training area was reportedly located near the southwest corner of Section 30.

The Technical Plan called for one soil sample to be collected at this site, but because of the lack of a precise location of the training area, no sample was collected at Site 16. It

is unlikely that mustard or any residue is still present in this area.

4.6.4 Site 17. Demilitarization Operations

At this site, M55 GB-filled rockets and M34 GB clusters were apparently demilitarized and decontaminated (Jones, et al, 1977). No date or procedures for these activities are known.

It has been reported that this area was used to remove fuses from 2,000 or 3,000 "leakers," i.e., GB-filled ordnances which were leaking. After defusing, the bombs were taken to the North Plants where holes were punched in them and the GB saved. No GB was dumped at this site, although some may have leaked out. No disposal pits were reported and any GB spilled or leaked would have been decontaminated with caustic (Donnelly, personal communication, 1982).

As part of the Technical Plan, two soil samples were taken near the two buildings located at Site 17. The results of the sampling are given in Table 4-8. No detectable amounts of arsenic, chloride, sodium or sulfates were found. Fluoride levels in the soil were between 3 ppm and 4 ppm, or the same as levels found in control samples.

**TABLE 4-8
RESULTS OF CHEMICAL ANALYSIS FOR SITE 17**

Sample No.	Extract	As (ppm)	Cl (ppm)	F (ppm)	Na (ppm)	SO ₄ (ppm)
SS3-3	Water	BDL	BDL ¹	3	BDL ¹	BDL ²
SS3-4	Water	BDL	BDL ¹	4	BDL ¹	BDL ²

NOTE: BDL - Below Detectable Level of 0.5 ppm.
BDL¹ - Below Detectable Level of 200 ppm.
BDL² - Below Detectable Level of 500 ppm.

Given the new information about the activities at this site and the lack of any abnormal levels of tested parameters, there appears to be no problem as to the migration of contaminants from Site 17.

4.6.5 Sites Not Addressed by Technical Plan

Review of aerial photographs after formulation of the Technical Plan has identified several areas about which little is known. Near the common corner of Sections 19, 20, 29, and 30, there is a small area being used for a classified U.S. Air Force project (Jones, et al, 1977).

An area of disturbance was noted in the northwest corner of Section 29. This area may be the same identified as Site 8 in Figure 2-2 since the area indicated for Site 8 in the central portion of Section 29 could not be confirmed by aerial photographs. It was reported that rockets may have been disposed of in this area (Buxton, personal communication, 1982). The potential for contaminant migration from such a disposal area would likely be low and would not represent a problem.

Also shown in Figure 4-5 is a revised mortar impact area (Site 15) that existed during the late 1940's. Review of the 1949 aerial photograph showed a perimeter road encircling an area in the southeast corner of Section 30. This encircled area is believed to be the primary impact area. The possibility exists for mortar rounds to have landed outside the perimeter. However, no part of the mortar impact area is believed to be in Sections 19 or 20 as these two Sections were outside the Arsenal boundary in the late 1940's.

4.7 EVALUATION OF SECTION 31

Located in the eastern portion of Rocky Mountain Arsenal, Section 31 contains two potential contamination sites as shown in Figure 4-6. The thickness of the unconsolidated material varies from 10 feet in the northern portion to about 25 feet in the eastern portion along First Creek. The water table is believed to be several feet below the creek bed. Water table contours indicate that the predominant direction of flow is towards the northwest. However, along the western edge of the Section, the flow is predominantly northward.

4.7.1 Site 9. New Toxic Storage Yard

Site 9 includes the shallow ponds along First Creek adjacent to the new Toxic Storage Yard. These ponds are believed to be expressions of the water table. Fish kills, which may be related to the depressed water levels in the ponds, have been reported. Surface water runoff from the Toxic Storage Yard drains into some of the ponds and into a tributary of First Creek north of the ponds. Spills of mustard and nerve gases have been reported near the entrance to the yard. GB and mustard demil wastes contained in fibreboard barrels are currently stored in the new Toxic Storage Yard.

The Toxic Storage Yard, by definition, is an area in which nerve gas, mustard, and perhaps other toxic materials were stored. These materials, because of their toxicity, are handled with caution, but there have been reports of spills. Contaminants may have been carried by surface water runoff to the ponds.

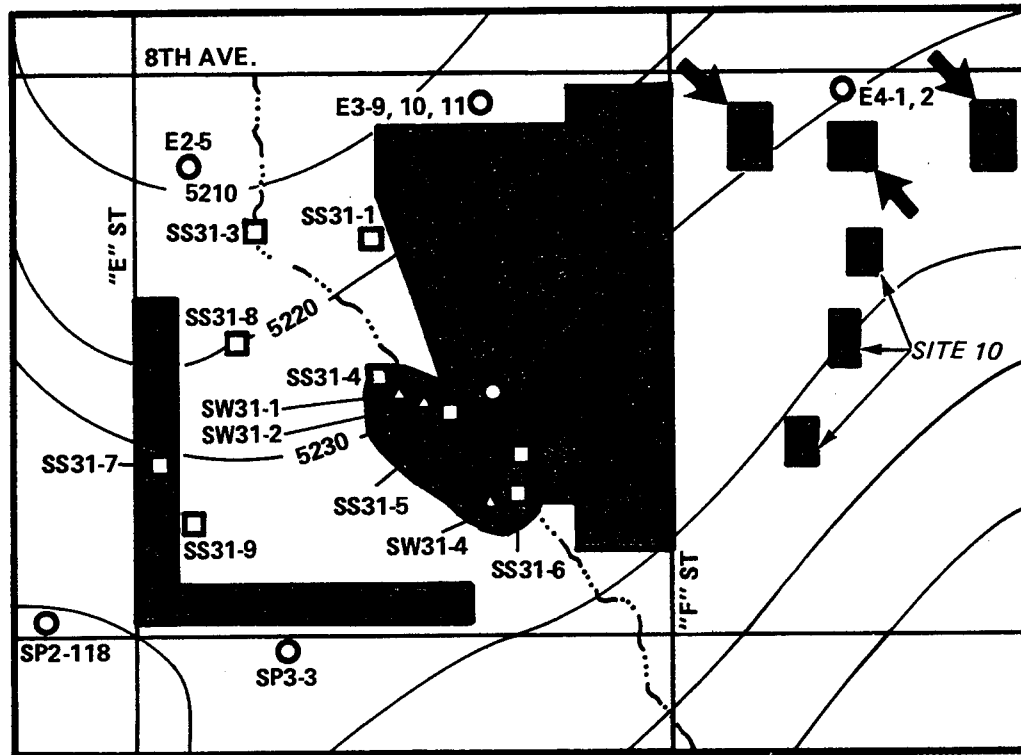

EXPLANATION

PERIOD SITE BEGAN

- 1942 - 1952
- 1952 - 1964
- 1964 - PRESENT

SAMPLE TYPE

- SS - SOIL SAMPLE
- MONITORING WELL
- SW - SURFACE WATER SAMPLE
- GS - GEOLOGIC SAMPLE

5190 - GROUNDWATER CONTOUR

AREA NOT ADDRESSED IN TECHNICAL PLAN

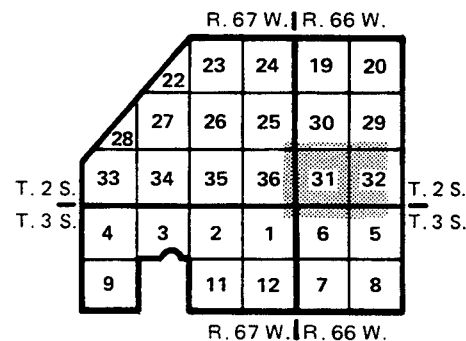

**FIGURE 4-6
POTENTIAL CONTAMINATION SOURCES IN SECTION 31,
ROCKY MOUNTAIN ARSENAL, DENVER, COLORADO**

Four soil samples, two sediment samples, and three surface water samples were collected in the vicinity of the ponds, First Creek and its tributaries. One groundwater sample was taken from a monitoring well installed near the southwest corner of the new Toxic Storage Yard. In addition, the groundwater quality in three regional wells was reviewed.

Results of chemical analysis for Site 9 are given in Table 4-9. Four of the six soil samples did not contain any organic compounds as indicated by the GC/MS screening. Samples SS31-1 and SS31-3 contained diethyl phthalate; SS31-3 also contained cyclohexanone. Both compounds were found in the control samples collected on Rocky Mountain Arsenal.

**TABLE 4-9
RESULTS OF CHEMICAL ANALYSIS FOR SITE 9**

Sample No.	OXAT (ppm)	DITH (ppm)	CPMS (ppm)	CPMSO (ppm)	CPMSO ₂ (ppm)	Comments
31-12	BDL	BDL	BDL	BDL	BDL	Downgradient of southeast corner of yard
Regional Well	OXAT (ppm)	DITH (ppm)	CPMS (ppm)	CPMSO (ppm)	CPMSO ₂ (ppm)	Comments
E2-5	—	BDL	—	BDL	BDL	Downgradient of northeast corner of yard
E3-9	—	BDL	—	BDL	BDL	
SP21-2	—	BDL	—	BDL	BDL	Upgradient
Sample No.	GC/MS Screen Compounds Detected					
SS31-1	Diethyl phthalate					
SS31-2	None					
SS31-3	Diethyl phthalate, cyclohexanone					
SS31-4	None					
SS31-5	None					
SS31-6	None					
SW31-1	Nonyl benzene, DCPD derivative, phthalates					
SW31-2	Diethyl & Dibutyl phthalates					
SW31-4	Cyclohexanone					

NOTE: BDL - Below Detectable Level of 0.2 ppm.

Phthalates and cyclohexanone were also present in two surface-water samples. Sample SW31-1 contained a DCPD derivative and nonyl benzene in addition to phthalates. None of the groundwater samples from regional or site-specific monitoring wells tested positive for specific organic compounds.

The sampling results do indicate that some organic compounds are present in the soils and surface water near the new Toxic Storage Yard. Additional testing will be required to quantify the levels of organic compounds present and their migration potential.

4.7.2 Site 18. Storage Facilities

Site 18, also in Section 31, includes several storage warehouses with concrete floors. Mustard, GB, and phosgene demil salts are stored in these warehouses. There are reports of GB and VX nerve gas spills in this area (Jones, et al, 1977).

The demil salts contain the residues of neutralization of the original chemical agents. The salts that might be expected could include some phosphate, chloride, and sulfate. Since neutralization would have disrupted the original molecular structure, the residues are inorganic salts and organic substances of lower toxicity.

Three soil samples were collected at this site. Two soil samples were analyzed for arsenic, chloride, fluoride, phosphorus, and sulfates. Soil Sample SS31-7 was taken near

a building in which nerve gas was reportedly spilled. Sample SS31-9 was collected in an area where a vegetation stress or change was detected on aerial photographs. A GC/MS screen was conducted on the third soil sample which was taken downslope from the warehouses. The groundwater quality of three regional wells was also reviewed.

Table 4-10 gives the results of the analytical testing for Site 18. The inorganic analysis on the two soil samples extracted by water showed nothing above detection levels except for fluoride at 3 ppm and 6 ppm which was at or slightly above fluoride concentrations in control samples (Table 4-1). Fluoride was also well below the drinking water standard of the 2.4 ppm concentration limit in the groundwater samples. Phthalate acid esters and diisopropyl ethyl phosphate were detected by means of GC/MS screening.

**TABLE 4-10
RESULTS OF CHEMICAL ANALYSIS FOR SITE 18**

Sample No.	Extract	As (ppm)	Cl (ppm)	F (ppm)	PO ₄ (ppm)	SO ₄ (ppm)	
SS31-7	Water	BDL ¹	BDL	6	*	BDL ²	
SS31-8	Water	BDL ¹	BDL	3	*	BDL ²	
Regional Well		As (ppm)	Cl (ppm)	F (ppm)	PO ₄ (ppm)	SO ₄ (ppm)	Comments
SP3-3		—	77	1.20	—	250	Upgradient
SP2-118		—	30	.57	—	770	Upgradient
E2-5		—	103	1.50	—	308	Downgradient
Sample No.	Extract	GC/MS Screen Compounds Detected					
SS31-9	Water	Diethyl and dibutyl phthalates, possible diisopropyl ethyl phosphate					

NOTE: BDL - Below Detectable Level of 200 ppm.
 BDL¹ - Below Detectable Level of 0.5 ppm.
 BDL² - Below Detectable Level of 500 ppm.
 * - Analysis deleted by Rocky Mountain Arsenal Laboratory.

The phosphate compound may be related to compounds used as stabilizers in GB, but is not related to GB itself. The phthalate esters were also present in control soil samples.

No migration of contaminants was detected from Site 18 from the data analyzed.

4.7.3 Sites Not Addressed by Technical Plan

Review of aerial photographs of Section 32 indicates three disturbed areas in the northern portion of the Section. No documented information was found to explain these areas.







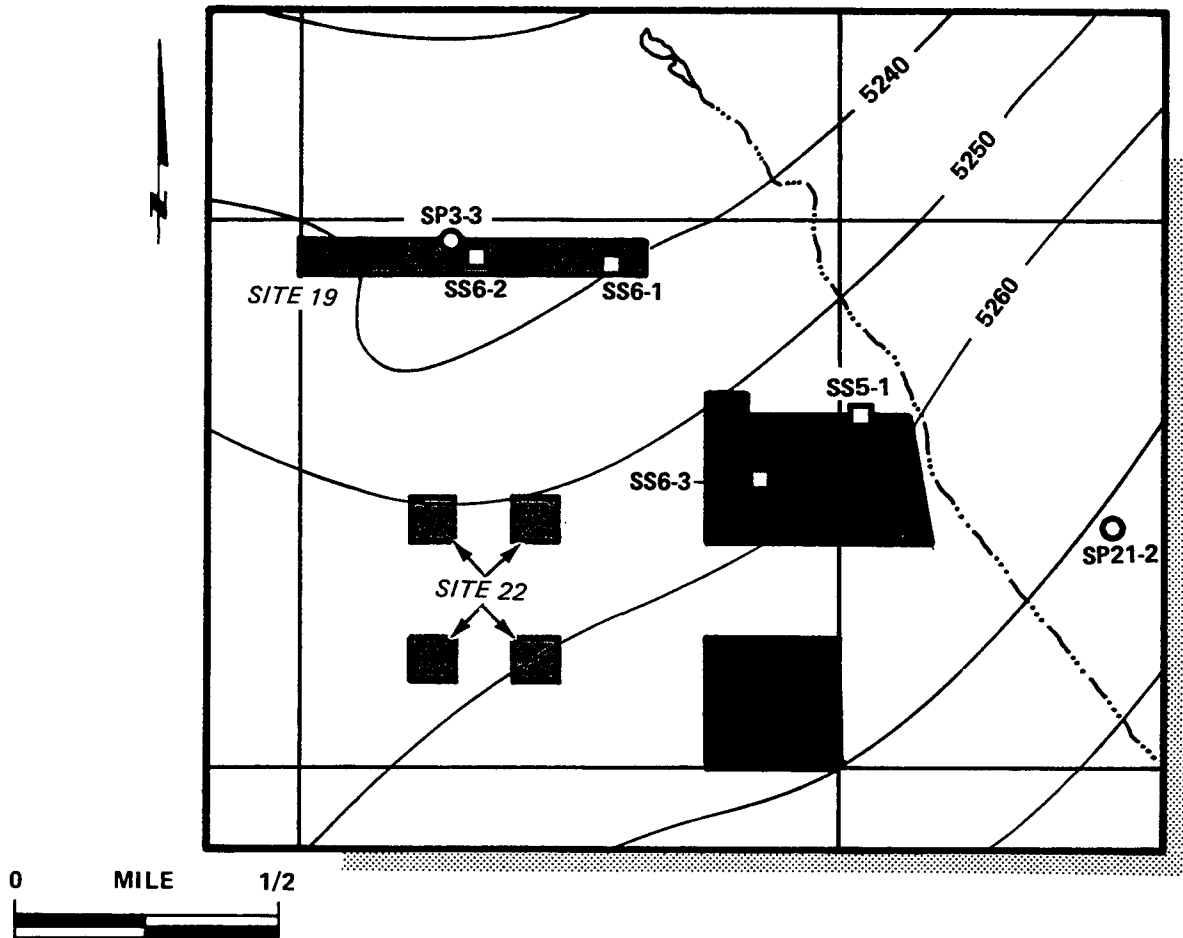

They appear to be shallow pits of some type. A later sequence of aerial photographs shows a faster rate of revegetation than observed for other disposal pits. This may suggest that activity in these areas was surficial rather than pit-type.

4.8 EVALUATION OF SECTION 6

Section 6, located in the southeastern portion of Rocky Mountain Arsenal, contains two potential contamination sites evaluated by the Technical Plan, shown on Figure 4-7. A site in Section 5 immediately adjacent to Section 6 is also discussed.

The thickness of the alluvium varies from 30 feet in the southern part of the Section to 20 feet along 7th Avenue. Water table contours indicate that groundwater flow is predominantly northward. It should be noted that the data were not sufficient to clarify the hydraulic situation near Upper Derby Lake. Depth to water varies from 10 feet in the south to about 15 in the northern portion of the Section.

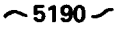

PERIOD SITE BEGAN		EXPLANATION	
		SAMPLE TYPE	
	1942 - 1952		SS - SOIL SAMPLE
	1952 - 1964		- MONITORING WELL
	1964 - PRESENT		SW - SURFACE WATER SAMPLE
	5190 GROUNDWATER CONTOUR		GS - GEOLOGIC SAMPLE

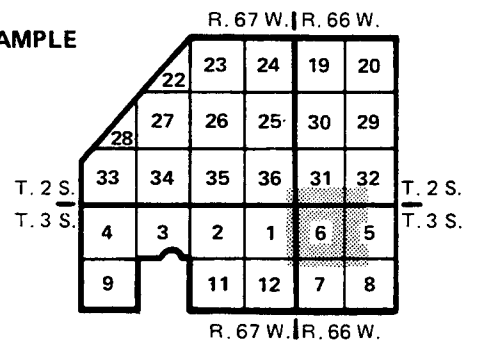

FIGURE 4-7
 POTENTIAL CONTAMINATION SOURCES IN SECTION 6,
 ROCKY MOUNTAIN ARSENAL, DENVER, COLORADO

4.8.1 Site 19. Storage Facilities

Buildings 786, 787, and 788 contain salts resulting from the mustard and GB demilitarization activity between 1969 and 1973. No release of the contaminants has been reported. There was a reported GB spill in Building 788, the date of which is unknown (Jones, et al, 1977).

Mustard salts are residues from demil operations on the mustard gas. Presumably, the residual salts have a low toxicity. They may have excess amounts of the neutralizing chemicals, in which case materials such as sulfate or chloride would be present. The GB spill area was probably treated with sodium hydroxide to decompose the GB.

Two soil samples were collected at this site, one of which was subjected to the GC/MS screening scan and the other was analyzed for inorganic compounds - chloride, fluoride, sodium, and sulfate. Results of the analysis are given in Table 4-11. The soil sample tested for inorganics contained

TABLE 4-11
RESULTS OF CHEMICAL ANALYSIS FOR SITE 19

Sample No.	Extract	Cl (ppm)	F (ppm)	Na (ppm)	SO ₄ (ppm)	
SS6-2	Water	BDL	5	BDL	BDL ¹	
Regional Well		Cl (ppm)	F (ppm)	Na (ppm)	SO ₄ (ppm)	Comments
SP3-3*		77	1.2	124	250	Downgradient
Sample No.	Extract	GC/MS Screen Compounds Detected				
SS6-1	Water	Cyclohexanone				

NOTE: BDL - Below Detectable Level of 200 ppm.
BDL¹ - Below Detectable Level of 500 ppm.

* - BTA, CPMSO, CPMSO₂, DITH were all below detectable level of 0.2 ppm.

5 ppm of fluoride, which was approximately twice the level measured in control samples. The only organic compound found in Soil Sample SS6-1 was cyclohexanone, which was also detected on one of the control soil samples. The water quality of a downgradient regional well failed to show any contamination. No contamination was indicated by the sampling program conducted at Site 19.

4.8.2 Site 20. Old Toxic Storage Yard

This site is the old Toxic Storage Yard which was used prior to 1969. The area of a mustard spill, approximately 0.01 acres and presently fenced off, is near the middle of the yard. The date of the spill is unknown.

Mustard is a vesicant, a material irritating and corrosive to epithelial tissue. It can be decomposed rapidly by hypochlorite solution and, after exposure, may hydrolyze in the environment. This would probably leave a residue of sulfate and chloride. Minor amounts of mustard that may have been spilled have almost certainly hydrolyzed to thiodiglycol, which is a water-soluble compound.

One soil sample was taken within the fenced area and found not to contain any chemical agent. The sample was then analyzed for specified organic compounds. The water quality from regional well SP3-3 was reviewed for downgradient groundwater quality.

Oxathiane, a mustard decomposition product, was detected at a level of 445 ppm in the soil sample. The other organic compounds, DITH, CPMS, CPMSO, and CPMSO₂, were below the

detection levels of 20 ppm. The water quality in well SP3-3 (see Table 4-11) did not indicate any unusual levels of inorganic compounds and the organic compounds BTA, CPMSO, CPMSO₂, and DITH were all below detectable levels. Results of the chemical analysis for Site 20 are given in Table 4-12.

**TABLE 4-12
RESULTS OF CHEMICAL ANALYSIS FOR SITE 20**

Sample No.	Extract	OXAT (ppm)	DITH (ppm)	CPMS (ppm)	CPMSO (ppm)	CPMSO ₂ (ppm)	Comments
SS6-3	Water	445	BDL	BDL	BDL	BDL	Negative chemical agent tests

NOTE: BDL - Below Detectable Level of 0.2 ppm.

The oxathiane that may leach from the soil in the area of the mustard spill has the potential to migrate, but the volume of contaminant that could reach the groundwater system is limited and probably would not be detectable in downgradient water samples.

4.8.3 Site 23. Outside Storage Area

This site lies east of the old Toxic Storage Yard in Section 5. There is the potential for chemical agent H and HD contamination in the west central part of the site. It was reported that incendiary weapons were stored in this area and not chemical agent-filled munitions (USATEC, 1973).

One soil sample was collected at Site 23 where surface water was likely to drain from the storage area. The sample was tested for chemical agent before the sample was screened by GC/MS for organic compounds. The results of the soil testing are given in Table 4-13.

**TABLE 4-13
RESULTS OF CHEMICAL ANALYSIS FOR SITE 23**

Sample No.	Extract	OXAT (ppm)	DITH (ppm)	CPMS (ppm)	CPMSO (ppm)	CPMSO ₂ (ppm)	Comments
SS5-1	Water	BDL	BDL	BDL	BDL	BDL	Negative chemical agent tests

NOTE: BDL - Below Detectable Level of 0.2 ppm.

None of the organic compounds OXAT, DITH, CPMS, CPMSO, or CPMSO₂ were found at concentrations above detectable levels. The limited sampling does not indicate any contaminants present in the soil at Site 23.

4.9 EVALUATION OF SECTION 36

Section 36, as shown in Figure 4-8, is located in the center of Rocky Mountain Arsenal and contains numerous disposal pits as well as Basin A. Other reports have investigated the disposal activities in this Section (Moloney, 1982) with most of the investigations dealing with contaminant migration through the Basin A neck area. The Technical Plan for this study addressed the possibility of contaminant migration to the northeast of Section 36.

The thickness of the alluvium varies between 10 and 30 feet. The water table is in the alluvium in the southwestern half and the extreme northeastern corner of Section 36. Depth to water ranges from 15 feet to more than 30 where the water table lies in the Denver formation. Water table contours indicate a north-south groundwater divide near the center of the Section. Groundwater flow is to the north and northwest on the west side of the divide and to the east and northeast on the east side of the divide.

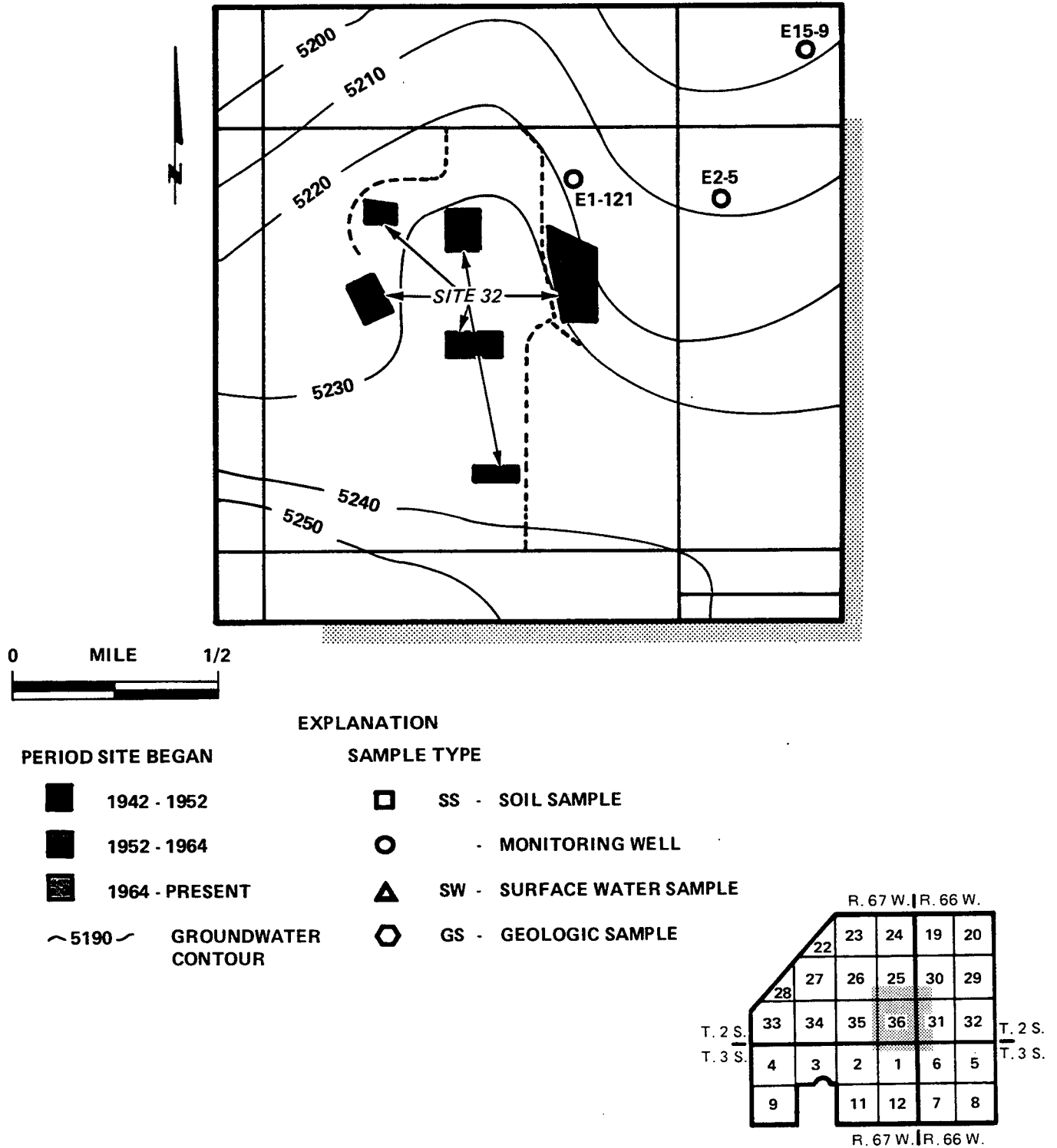

FIGURE 4-8
POTENTIAL CONTAMINATION SOURCES IN SECTION 36,
ROCKY MOUNTAIN ARSENAL, DENVER, COLORADO

4.9.1 Site 32. Section 36 Pits (Northeastward Migration)

Pits in this Section have reportedly been used for a variety of disposal activities, including a sanitary landfill, disposal of GB manufacturing residue and insecticides, destruction of incendiary weapons, and disposal of numerous one-ton containers of mustard and pieces of equipment. The ton containers were removed in February 1974 and disposed of by incineration (Hurt, 1974). There is also an incendiary bomb testing facility in the southeast corner of the Section. Unexploded ordnance may be found in this area. The pits have to be regarded as having received many of the organic chemical agents and inorganic heavy metals associated with explosives and catalysts.

The Technical Plan primarily addressed the possibility of northeastward migration of contaminants via the groundwater system since this area is not considered in existing control programs. The water quality results of three regional wells were reviewed as indicators of contaminant migration and are presented in Table 4-14.

TABLE 4-14
RESULTS OF CHEMICAL ANALYSIS FOR SITE 32

Regional Well	Ca (ppm)	Cl (ppm)	Fe (ppm)	K (ppm)	Mn (ppm)	Na (ppm)	NO ₃ (ppm)	SO ₄ (ppm)	Hardness (ppm)	Comments
E15-9	84	83	-	5.9	-	196	-	480	-	Downgradient
E2-5	380	103	-	3.3	-	168	-	308	-	Downgradient
E1-121	380	195	-	5.9	-	780	-	2120	-	Downgradient

The quality of the water from the three regional wells is typical for wells screened in the upper Denver formation. Sulfates ranged from 308 ppm to 2120 ppm while sodium ranged from 168 ppm to 780 ppm. Potassium varied from 3.3 to 5.9 ppm. The alluvium in the northeast corner of Section 36 is unsaturated. The water quality results indicate no degradation of groundwater quality northeast of the Section 36 pits. The groundwater flow system in Section 36 is influenced greatly by the groundwater mound in the South Plants area. Improved definition of the hydrology in this area or changes in the existing conditions may necessitate future monitoring for possible northeastward migration of contaminants from Site 32.

4.10 EVALUATION OF SECTIONS 11 AND 12

Two potential contamination sources were investigated in Sections 11 and 12, which are located in the south central portion of Rocky Mountain Arsenal as shown in Figure 4-9. The unconsolidated material overlying the Denver formation varies in thickness from 75 feet at the south boundary to approximately 85 feet along Sixth Avenue. A buried valley roughly parallels Sixth Avenue. The depth to water varies from 25 feet near the south boundary to 5 to 10 feet along Ladora Lake in the north. The configuration of the water table shows declining water levels toward the northwest from elevation 5260 feet in the south to 5200 feet in the northwest. The groundwater flow is in a northwesterly direction.

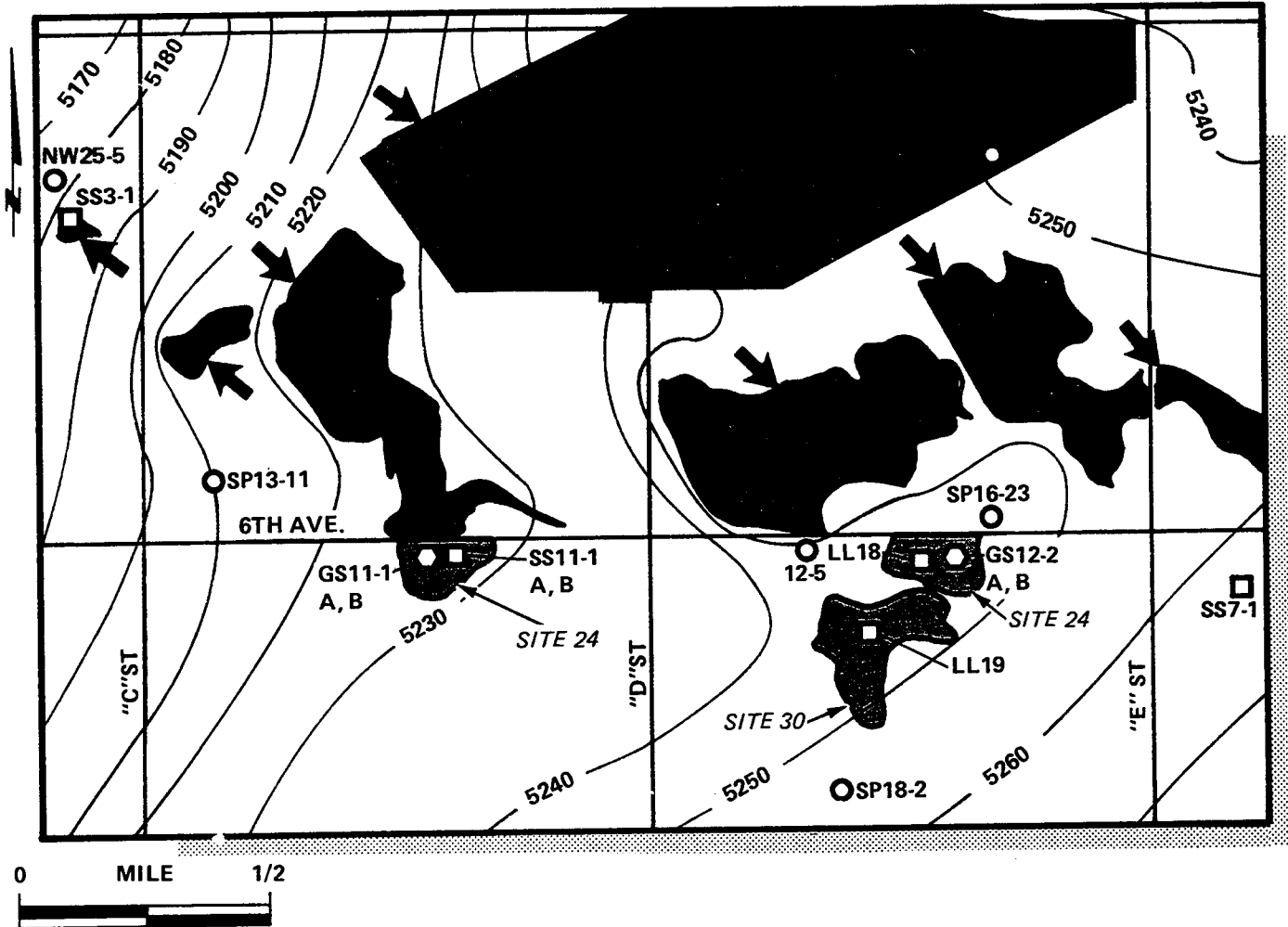

EXPLANATION

PERIOD SITE BEGAN	SAMPLE TYPE
1942 - 1952	SS - SOIL SAMPLE
1952 - 1964	- MONITORING WELL
1964 - PRESENT	SW - SURFACE WATER SAMPLE
5190	GS - GEOLOGIC SAMPLE
AREA NOT ADDRESSED IN TECHNICAL PLAN	

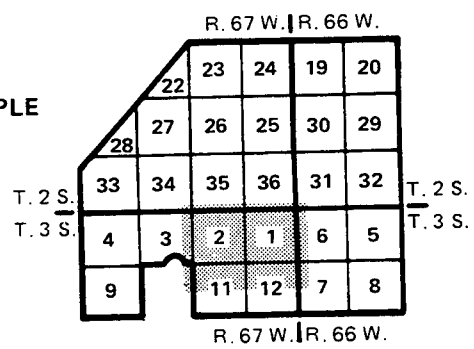

FIGURE 4-9
POTENTIAL CONTAMINATION SOURCES IN SECTIONS 11 AND 12,
ROCKY MOUNTAIN ARSENAL, DENVER, COLORADO

4.10.1 Site 24. Lake Dredge Disposal Area

Sludge was dredged from the lakebeds about 1964. It contained Aldrin and Dieldrin resulting from accidental discharges to the lakes. The sludge was deposited in a low area south of Ladora Lake in the northern portion of Section 11 and also in an area south of Upper Derby Lake in Section 12.

Aldrin and Dieldrin are highly chlorinated organic pesticides. Aldrin converts relatively rapidly to Dieldrin under the environmental conditions present at the Arsenal. However, Dieldrin is a long-lived compound in soil and sediments. Frequently the analysis for the compound is given as a summation because of their interconversion. The compounds would be classified as highly toxic, but their presence in sludge would essentially encapsulate them because of their very low mobility in soil.

In each of the two disposal areas, geologic samples were collected from soil borings to obtain samples of the dredgings and the underlying soil. Samples were taken at 5 to 6.5 feet in each boring, at 17 to 18.5 feet in Section 11 and 15 to 16.5 feet in Section 12. A monitoring well was installed downgradient of the disposal area in Section 12 to check for possible groundwater contamination. Two soil samples were collected at one location in the disposal area in Section 11. One was taken at a depth of zero to one foot and the other from the two to three foot depth. An additional soil sample was collected downgradient of the south lakes in Section 3 to check for possible contamination

from lake overflows. The water quality results from two upgradient and one downgradient regional wells were also reviewed.

The results of the chemical analysis for Site 24 are given in Table 4-15. The geologic sample GS12-2A (5' -6.5') indicated the presence of Dieldrin at 0.11 ppm, Endrin at 0.01 ppm, and mercury at 0.12 ppm. However, the underlying soil sample taken approximately three feet below the dredgings did not contain any contamination (GS12-2B, 15' -16.5'). The geologic samples taken from the soil boring in Section 11 were not contaminated. Dieldrin was measured at 0.01 ppm and mercury at 0.11 ppm in Soil Sample SS11-1A, and Sample SS11-1B contained 0.13 ppm of mercury. Levels of Aldrin, Dieldrin, and Endrin below 0.06 ppm were found in the Soil Sample SS3-1

**TABLE 4-15
RESULTS OF CHEMICAL ANALYSIS FOR SITE 24**

Sample No.	Extract	Aldrin (ppm)	Dieldrin (ppm)	Endrin (ppm)	Hg (ppm)	Comments
GS12-2A	Solvent	BDL	0.11	0.01	0.12	Downgradient
GS12-2B	Solvent	BDL	BDL	BDL ¹	BDL ²	
GS11-1A	Solvent	BDL	BDL	BDL ¹	BDL ²	
GS11-1B	Solvent	BDL	BDL	BDL ¹	BDL ²	
SS3-1	Solvent	.01	.01	.06	BDL ²	
12-5		BDL ³	BDL ³	BDL ³	-	
SS11-1A	Solvent	BDL	.01	BDL ¹	0.11	
SS11-1B	Solvent	BDL	BDL	BDL ¹	0.13	
Regional Well		Aldrin (ppm)	Dieldrin (ppm)	Endrin (ppm)	Hg (ppm)	Comments
SP16-23		BDL ⁴	BDL ⁴	BDL ⁴	-	Upgradient
SP13-11		BDL ⁴	BDL ⁴	BDL ⁴	-	Downgradient
NW25-5		BDL ⁴	.0019	BDL ⁴	-	Downgradient

NOTE:

BDL - Below Detectable Level of .004 ppm.
BDL¹ - Below Detectable Level of .003 ppm.
BDL² - Below Detectable Level of .02 ppm.

BDL³ - Below Detectable Level of 0.0002 ppm.
BDL⁴ - Below Detectable Level of 0.001 ppm.

west of the lakes. The downgradient groundwater sample did not show the presence of pesticide contamination, nor did either of the upgradient regional wells. However, Dieldrin was found in the downgradient regional well NW25-5 at a concentration of 0.0019 ppm.

The geologic samples taken in Section 12 indicate that no migration of the contaminants is occurring from the disposal areas. This observation is supported by the groundwater sample collected in the well adjacent to the disposal area. The reason the geologic samples taken in Section 11 do not show contamination is that the soil boring apparently missed the actual area of disposal. Aerial photographs taken in 1965 show a large disturbed area in Section 11. However, the dredgings may have only been deposited in a small, low-lying area while the rest of the disturbance reflects the area where the cap soil was obtained. Soil sampling in the smaller area in Section 11 did find Dieldrin and mercury present in the topsoil.

The presence of a low concentration of Dieldrin in the groundwater at well NW25-5 does not indicate that the contamination came from the dredge disposal areas. Because geologic sampling through the dredgings failed to show pesticide migration and since water in the lakes was known to have been contaminated, it is probable that groundwater has been affected by the infiltrating surface water. The concentration of Dieldrin observed at the regional well should not represent a migration problem because chemical attenuation and dispersion will tend to further reduce the concentration between the well and the Arsenal boundary.

4.10.2 Site 30. The Rod and Gun Club Pond

In the late 1960's, a new pond known as the Rod and Gun Club Pond was developed in a natural low area immediately south of the lake dredge disposal area in Section 12. This new pond was connected to an overflow channel from Lower Derby dissecting the disposal area. At periods of high water levels in Lower Derby, water overflows into the Rod and Gun Club Pond.

No new soil borings were drilled at Site 30, and no new soil samples were taken. The analytical results of two soil samples collected in the Lower Lakes study as part of the Interim Beneficial Action Program were reviewed (Gregg, personal communication, 1982).

Soil samples taken in the overflow ditch and in the sediments of the Rod and Gun Club Pond indicate pesticide contamination as presented in Table 4-16. The soil samples contained 1 ppm of Dieldrin and 0.19 ppm of Aldrin in the sample from the bottom of the pond. The sample from the overflow ditch contained 0.51 ppm of Dieldrin, .024 ppm of Aldrin, and .011 ppm of Endrin.

**TABLE 4-16
RESULTS OF CHEMICAL ANALYSIS FOR SITE 30**

Sample No.	Aldrin (ppm)	Dieldrin (ppm)	Endrin (ppm)	Hg (ppm)	Comments
LL-18	.024	.051	.011	BDL	Collected 2/6/82
LL-19	.190	1.0	BDL ¹	BDL	Collected 2/6/82

NOTE: BDL - Below Detectable Level of 0.2 ppm.

BDL¹ - Below Detectable Level of 0.02 ppm.

The contamination present in the overflow ditch and Rod and Gun Club Pond sediments is probably the result of surface water erosion and deposition. The geologic samples taken in Section 12 indicate that no migration of the contaminants is occurring from the disposal area or the Rod and Gun Club Pond via the groundwater system.

4.11 EVALUATION OF SECTION 3

Section 3, shown in Figure 4-10, is in the southwestern portion of Rocky Mountain Arsenal. The thickness of the alluvium varies from 70 feet in the southeast to about 100 feet in the northwest portion of the Section. Depth to water varies from about 10 feet in the southeast to 60 feet in the northwest. Water table contours show that groundwater flow is northeast toward the Arsenal boundary.

4.11.1 Site 11. DBCP Spill in Rail Classification Yard

This site is the suspected area of a DBCP (Nemagon) spill which apparently occurred in the 1960's. The exact location, nature, and quantity of the spill are not known. A DBCP plume extends approximately two miles to the northwest of the rail yard, but little definition of the DBCP distribution and concentration is available in the source area.

DBCP is a nematocide of high toxicity is relatively water soluble and mobile in soils and groundwater. Male workers manufacturing DBCP have been subject to sterility as a result of chronic contact.

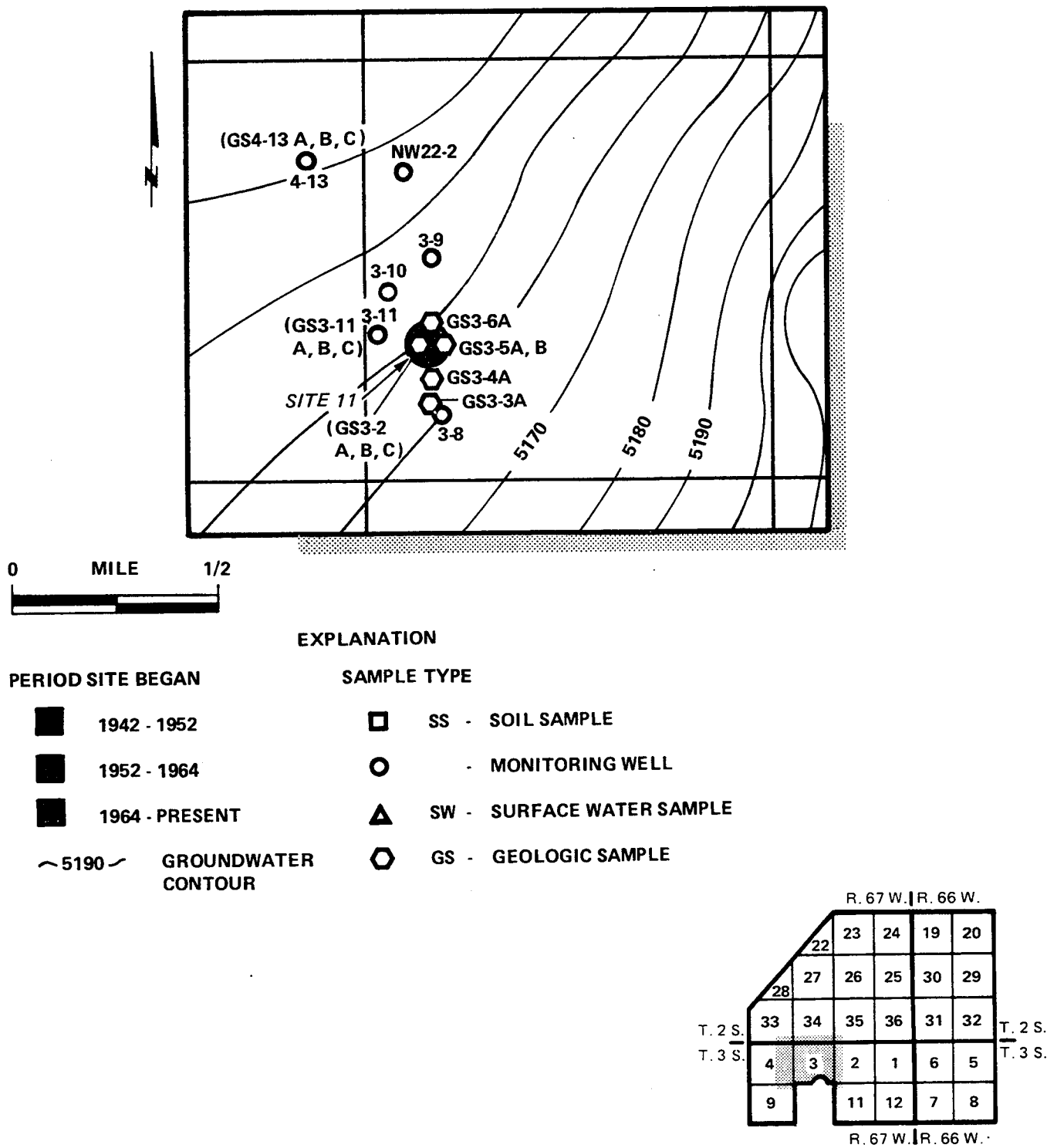

FIGURE 4-10
POTENTIAL CONTAMINATION SITES IN SECTION 3,
ROCKY MOUNTAIN ARSENAL, DENVER, COLORADO

The scope of work at Site 11 included the installation of two monitoring wells and the drilling of five soil borings to obtain geologic samples. The geologic samples were subjected to solvent extraction as well as water extraction to assist in the determination of the amount of the contaminant present in the soil and the amounts of DBCP that might be expected to leach out. Groundwater samples were collected from the two new monitoring wells and the water quality results for regional well NW22-2 were reviewed.

Prior to the implementation of the Technical Plan, personnel from Geraghty & Miller, Inc. and Shell Chemical collected six surface water samples in the vicinity of the rail yard which were analyzed by the Shell Laboratory. DBCP was detected at 0.3 parts per billion (ppb) in water flowing from a drainage system underlying the railroad tracks. No DBCP was detected in the other five samples. Information supplied by Shell Chemical also indicated that rail cars carrying DBCP were usually spotted on the third and fourth tracks from the west side of the yard and generally in the northern portion of the yard. This preliminary information determined the location of some of the sampling points.

Results of the chemical analysis at Site 11 are presented in Table 4-17. The two monitoring wells were drilled in areas where percolating surface water may have carried DBCP into the groundwater system. The geologic samples and the groundwater samples taken from monitoring wells 3-11 and 4-13 did not show any contamination from DBCP.

The three geologic samples taken from soil borings GM3-2, located adjacent to the Shell well S-23 near the rail yard,

indicated the presence of DBCP in two of three geologic samples extracted by solvent. The two geologic samples, taken from near the soil surface and near the water table, had DBCP levels of 0.4 ppb and 1.5 ppb, respectively. The replicate set of geologic samples from this well was subjected to water extraction and DBCP was not detected. Groundwater samples collected from well S-23 by Shell Chemical contain approximately 30 ppb of DBCP.

TABLE 4-17
RESULTS OF CHEMICAL ANALYSIS FOR SITE 11

Sample No.	Water Extract* DBCP (ppb)	Solvent Extract** DBCP (ppb)	Comments
GS3-11A	BDL	BDL ²	
GS3-11B	BDL	BDL ²	
GS3-11C	BDL	BDL ²	
GS3-2A	BDL	0.4	
GS3-2B	BDL	BDL	
GS3-2C	BDL	1.5	
GS3-3A	BDL	BDL	In the rail yard
GS3-4A	BDL	3.2	In the rail yard
GS3-5A	3.3	21.0	In the rail yard
GS3-5B	2.1	19.0	In the rail yard
GS3-6A	BDL	BDL	In the rail yard
GS4-13A	BDL	-	
GS4-13B	BDL	-	
GS4-13C	BDL	-	
3-11	BDL	BDL ¹	Downgradient
4-13	BDL	BDL ¹	Downgradient
NW22-2	BDL	-	Downgradient

NOTE: BDL - Below Detectable Level of .2 ppb.
BDL¹ - Below Detectable Level of 0.06 ppb.
BDL² - Below Detectable Level of 0.2 ppb.

*Analysis performed by Rocky Mountain Arsenal Laboratory
**Analysis performed by Shell Chemical Laboratory

Four shallow soil borings were drilled near the west side of the rail yard in a north-south line. The geologic samples from the soil borings at the northern and southern ends of

the rail yard did not indicate any DBCP contamination in the upper ten feet of soil. DBCP was detected at 3.2 ppb in the solvent extracted sample GS3-4A(2'-9'), but none was detected in the water extracted sample.

Two geologic samples were taken from a deeper soil boring approximately 100 feet east of Shell well S-23. The water extraction indicated a soil concentration of 3.3 ppb of DBCP near the surface and 2.1 ppb of DBCP at a depth of 45 feet. The levels of DBCP in the replicate geologic samples extracted by solvent were significantly greater than the water extracted samples. The shallow sample contained 21 ppb DBCP while the deeper sample had 19 ppb of DBCP. This soil boring did not penetrate to the water table.

Review of the available data for Site 11 indicates that the rail yard is the probable spill area. DBCP contamination has reached the groundwater system by direct percolation. Minor amounts of DBCP may have been carried away in the surface runoff, but it appears to be undetectable except in the immediate vicinity of the rail yard. The occurrence of a higher concentration of DBCP in the groundwater at well S-23 than in the surrounding soil tested indicated that greater concentrations of DBCP in the soil may be present somewhere upgradient.

The two samples indicating DBCP in both the water extract and solvent extract yield some information relative to the leachability of DBCP in the soil. The ratios of solvent extract concentration to water leachate concentration were 6.4:1 and 9:1 for the two geologic samples. It is not known if the magnitude of the ratio is representative or if the

quantity of DBCP leached by the procedure used is indicative of what might be expected to reach the groundwater system.

Three main questions remain unresolved relative to the DBCP contamination near the rail classification yard. The probable area of the spill has been better defined, but the data indicates the likelihood of greater soil concentrations of DBCP than those found in this study. The location and extent of this area are not known. Secondly, the leachability of DBCP from the soil by the leaching procedure used has been estimated from the data obtained; additional information is needed to determine whether this is representative of field conditions. The third question deals directly with the rate of migration of DBCP in the groundwater flow system. General information is available from the literature on the transport mechanisms of DBCP, but additional review and analysis of existing data may yield more site-specific data on the migration rate.

4.12 EVALUATION OF SECTION 4

Section 4 is located in the southwestern corner of Rocky Mountain Arsenal. Two potential contamination sites, shown in Figure 4-11, were evaluated by the Technical Plan. The thickness of the alluvium varies from about 65 feet along the west boundary to more than 130 feet in the vicinity of B Street just west of well NW-22. A buried valley runs through this area in a northwesterly direction. Depth to water is about 50 feet and the direction of groundwater flow is northwesterly. The groundwater system has been confirmed by extensive drilling in the adjacent Section to the north in connection with the Nemagon plume study and control system along the northwest boundary.

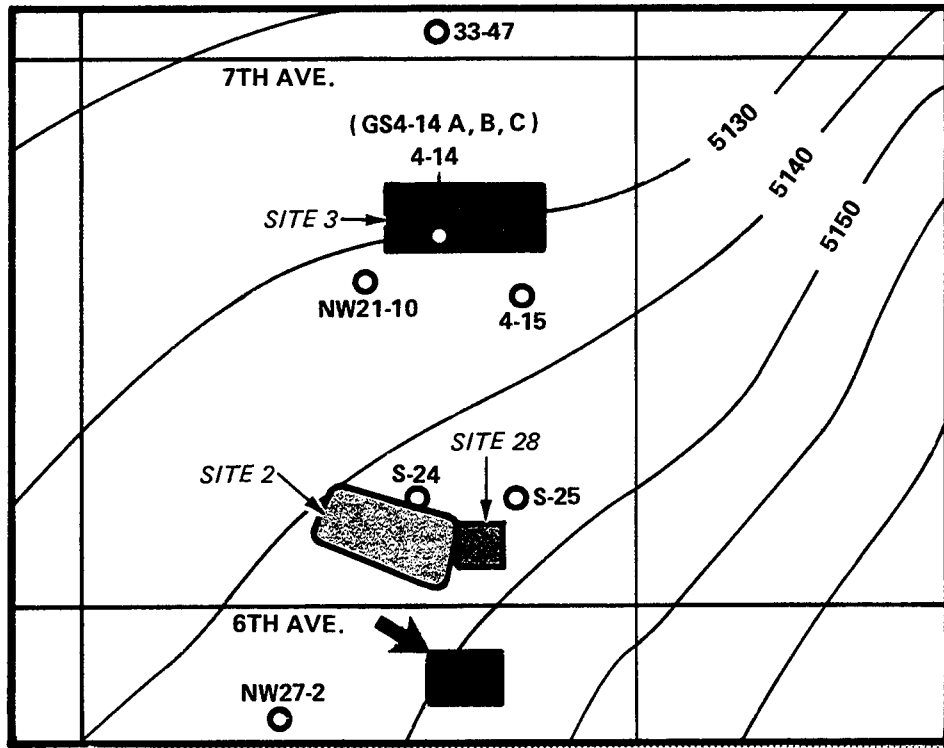

PERIOD SITE BEGAN		EXPLANATION	
		SAMPLE TYPE	
	1942 - 1952		SS - SOIL SAMPLE
	1952 - 1964		- MONITORING WELL
	1964 - PRESENT		SW - SURFACE WATER SAMPLE
	GROUNDWATER CONTOUR		GS - GEOLOGIC SAMPLE
	AREA NOT ADDRESSED IN TECHNICAL PLAN		

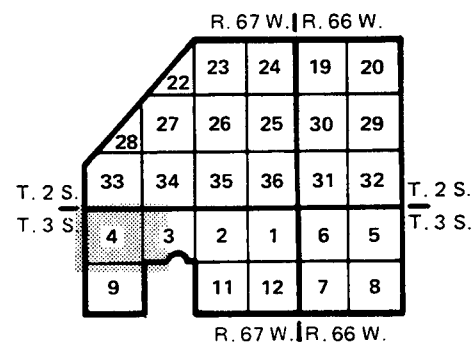

FIGURE 4-11
POTENTIAL CONTAMINATION SOURCES IN SECTION 4,
ROCKY MOUNTAIN ARSENAL, DENVER, COLORADO

4.12.1 Site 2. Sanitary Landfill

This landfill area lies southwest of the rail classification yard and was operated from the 1950's to the early 1970's. The presumption is that this disposal facility was a standard landfill which has received a mixture of putrescible and non-putrescible materials.

Characteristically, leachate from such a landfill has a high BOD, a high COD, and probably elevated concentration of sodium, iron, and calcium. Given the climate of the Denver area, the production of leachate from this site is probably small.

Existing wells S-24 and S-25 were sampled and analyzed for calcium chloride, iron, sodium, sulfate, and hardness as indicators of leachate from a landfill. The water quality results for regional well NW27-2 may be typical of upgradient water quality and well NW21-10 was used to represent downgradient water quality.

Analytical results are given in Table 4-18. The results for wells S-24 and S-25 are similar to background water quality

**TABLE 4-18
RESULTS OF CHEMICAL ANALYSIS FOR SITE 2**

Sample No.	Ca (ppm)	Cl (ppm)	Fe (ppm)	Na (ppm)	SO ₄ (ppm)	Hardness (ppm)	Comments
S-24	69	39	BDL	44	100	236	Downgradient
S-25	54	45	BDL	51	89	224	Downgradient
Regional Well	Ca (ppm)	Cl (ppm)	Fe (ppm)	Na (ppm)	SO ₄ (ppm)	Hardness (ppm)	Comments
NW21-10	80	36	—	46.5	96	—	Downgradient
NW27-2*	157	78	—	133.0	360	—	Upgradient

NOTE: BDL - Below Detectable Level of .5 ppm.

* Tetrachloroethylene present at 3.4 ppb.

in this area. The leachate indicators--chloride, iron, and sodium--are not present in elevated concentrations. Iron is below detectable levels in both samples.

The water quality in regional well NW27-2, located southwest of Site 2, but not directly upgradient, has poorer water quality than does the downgradient well NW21-10. In addition, trichloroethylene was detected at 3.4 ppb in well NW27-2. No trichloroethylene was detected at wells S-24 and S-25, possibly because the well construction for these wells is different. The wells may sample a different portion of the aquifer.

The groundwater quality in wells near Site 2 does not indicate any degradation in water quality due to leachate from the landfill operations.

Periodic resampling of the downgradient wells may be desirable, but the probability of leachates from the landfill being detected is small considering the climate and the large volume of groundwater moving through this area.

4.12.2 Site 3. Disposal Trenches

This site was used from 1943 to the late 1950's. Unusable drums or containers of paints, lacquers, and solvents were reportedly buried in this area (Kuznear and Trautmann, 1980). Aerial photographs show backfilled trenches about 20 feet wide and 300 feet long.

If paints and solvents were deposited in this area, chemicals that might be present are ketones, esters, chlorinated

hydrocarbons, and straight hydrocarbons. Most of these chemicals are relatively water soluble and quite mobile in soil. Their toxicity is generally low, but there is a potential for groundwater contamination.

Two monitoring wells were installed at Site 3. One well was located between two of the trenches within the site and the other well was located immediately upgradient. Geologic samples were collected at 5'-6.5', 35'-41.5', and 70'-71.5' for chemical analysis from well 4-14 installed between the trenches. Groundwater samples were taken from both wells and from well 33-47, which is downgradient of Site 3. Analysis included inorganic and volatile organic compounds.

Results of chemical analysis for inorganic and volatile organic compounds are presented in Table 4-19. Volatile organics were analyzed for because the materials allegedly disposed of in the trenches would have contained major quantities of these substances. No degradation of water quality is indicated by comparing inorganic analysis of upgradient and downgradient wells.

The concentrations of inorganics in the geologic samples were low or undetectable in comparison to the groundwater concentrations.

Carbon disulfide was present in all three groundwater samples. Trichloroethylene was detected in one downgradient and the two upgradient groundwater samples. The distribution and concentration (traces in several instances of volatile organics) are more indicative of background concentrations

**TABLE 4-19
RESULTS OF CHEMICAL ANALYSIS FOR SITE 3**

Sample No.	Extract	Ca (ppm)	Cl (ppm)	Fe (ppm)	Na (ppm)	SO ₄ (ppm)	Hardness (ppm)	Comments
GW4-2		51	20	BDL ³	*	61	162	Within site
GW4-3		47	36	BDL ³	61	99	212	Upgradient
33-47		69	45	BDL ¹	76	93	248	Downgradient
GS4-2A	Water	45	BDL	BDL ⁴	BDL	BDL ²	-	
GS4-2B	Water	3	BDL	BDL ⁴	BDL	BDL ²	-	
GS4-2C	Water	9	BDL	5.0	BDL	BDL ²	-	
Sample No.	Volatile Organics Detected							
GW4-2	carbon disulfide (trace)							
GW4-3	carbon disulfide (trace), trichloroethylene							
33-47	carbon disulfide, trichloroethylene (trace)							

NOTE: BDL - Below Detectable Level of 200 ppm.
 BDL¹ - Below Detectable Level of .5 ppm.
 BDL² - Below Detectable Level of 500 ppm.
 BDL³ - Below Detectable Level of .1 ppm.
 BDL⁴ - Below Detectable Level of 1.0 ppm.
 * - Analysis deleted by Rocky Mountain Arsenal Laboratory.

than a distinct contribution by the disposal trenches. A background contamination by volatile organics may be further indicated by the presence of tetrachloroethylene in well NW27-2 located about three-quarters of a mile southwest.

Leachates from the disposal trenches are apparently not reaching the groundwater system in quantities sufficient to be discernable in the groundwater samples. Site 3 does not appear to represent a potential for the migration of contaminants.

4.12.3 Site 1. Radio Towers

A site near the center of Section 9 had been reported as possibly being a disposal area for grenades (Jones, et al, 1977). This site is not shown on Figure 4-11. Review of

aerial photographs indicates that Site 1 was outside the Rocky Mountain Arsenal perimeter fence. The 1949 aerial photograph clearly shows a series of five towers at this site. This reportedly was used by the FAA during this period (Donnelly, personal communication, 1982). Although no specific information has been located regarding FAA leases, discussions with FAA personnel have indicated that this site was most likely an Adcock range. This was a series of five antennae in a fivespot pattern and was a low frequency guidance beacon. In general, the Adcock system was in use between the 1930's and the 1960's, but no specific dates were determined for the operations in Section 9.

Available evidence indicates that no disposal activities took place near the center of Section 9. The lack of any operations that would have any type of contamination has been supported in other reports (Dept. of Army, 1975).

4.12.4 Site Not Addressed by Technical Plan

A disturbed area in the north-central portion of Section 9 was evident on the 1949 aerial photograph. No documented information was found to describe any activity which may have occurred in this area. It has been reported that this area was used for testing flame throwers during the late 1940's (Buxton, personal communication, 1982).

4.13 GROUP D SITES NOT ADDRESSED BY TECHNICAL PLAN

Twelve of the 32 potential contamination sites identified in Phase I were classified as Group D sites--sites which were unlikely to have contamination present. No sampling was

conducted at any of these sites, but a summary of the activities that occurred at each of the sites is given on a site-by-site basis. These sites can be located on Figure 2-2.

4.13.1 Site 5, Section 24. Disposal Pit

During the period of TX production (1964-1968), byproducts, rejected raw biological agent, and wastes were buried in the east central part of the Section. This material had less than 15% viable spores when it was buried. The waste products (about 70 tons) included some discharged demilled barrels that had contained biological agent. In December 1972, public pressure caused the Rocky Mountain Arsenal to investigate the TX disposal operations. Findings indicated that all sites and facilities associated with the TX program were successfully demilitarized (Jones, et al, 1977).

The material in question is a biological agent, not chemical. It is a fungus which is specific to wheat and induces a stem rust condition. The material stockpiled was the fungal spores which could be distributed over the crop to induce an outbreak of rust disease. The spores were later incinerated. The ashes were fumigated, dispersed, and disked into a 30-acre disposal site in Section 20. Based on this information, no evaluation was made of this site.

4.13.2 Site 8, Section 29. Disposal Pit

Reports indicate that rocket motors and other ordnance were disposed in this area. There may also be unexploded ordnance in this area, but these do not represent a migration

potential. Based on this information, no evaluation was made of this site (Jones, et al, 1977).

4.13.3 Site 10, Section 32. Burn Pits

There are three designated burn pits in the western portion of this Section. From the early 1950's to the mid-1960's, 20,000 to 30,000 one-thousand pound and five-hundred pound cluster bombs were detonated and allowed to burn. Each pit was cleaned out periodically. The scrap iron was reportedly demilled and sold. Chemicals in some of these incendiary weapons were magnesium, bunker C oil, white phosphorus, and black powder. Materials reportedly remain in this area from M-55 rocket testing (Jones, et al, 1977). The presumption is that the incendiary materials were destroyed during these operations. Based on this information, no evaluation was made of this site.

4.13.4 Site 12, Section 23. TX Study Area

The eastern half of this Section was used for growing TX-treated wheat. TX is an anti-crop pathogen. It was produced from 1964 to 1968 and was apparently tested on the crops during that period. One well is reported to be filled with TX-contaminated equipment (Jones, et al, 1977).

The material in question is a biological agent, not chemical. It is a fungus which is specific to wheat and induces a stem rust condition. Based on this information, no evaluation was made of this site.

4.13.5 Site 13, Section 19. Surface Disposal

In the southeast portion of the Section is an area where incinerated TX material was incorporated into the soil (Jones, et al, 1977). Based on this information, no evaluation was made of this site.

4.13.6 Site 14, Section 20. Surface Disposal

Ash and iron oxide residues from the electrostatic precipitator used in the mustard demil operations were incorporated into the soil at this site in the early 1970's (Jones, et al, 1977).

The iron oxide would simply add to the already high iron content of the soil and should have no impact at all. Other components of the ash might include small amounts of sulfate or chloride resulting from mustard decomposition. It is not likely that these other components would have the potential for significant contamination.

4.13.7 Site 15, Section 30. Impact Area

This is an impact area for testing mortars during the 1940's (see Figure 4-5). The mortars included high explosives and phosphorus. There is no indication that chemical agents were present at the site (Jones, et al, 1977).

The presumption would be that the explosive chemicals that were in the mortar shells would have detonated and left little or no contamination. However, unexploded ordnance, if

present, could contain some explosive material, but probably would not release it to the environment. Groundwater contamination or soil contamination is expected to be minimal under these circumstances.

4.13.8 Site 21, Section 6. Storage Area

This was a storage yard for high explosives associated with the old toxic storage yard (see Figure 4-7). No records indicate the presence of chemical agent in this area (Jones, et al, 1977).

The likelihood that significant amounts of contaminants from these explosives could have been lost to the environment is low; therefore, no evaluation of this site was made.

4.13.9 Site 22, Section 6. Storage Facilities

GB-filled ordnance was stored in the igloos in the southern part of the Section (see Figure 4-7). The exact date of storage is not known, but may have been from the late 1960's into the 1970's (Jones, et al, 1977). There is no reported release of any contaminant at this site and no evaluation of this site was made.

4.13.10 Site 27, Section 7. Storage Area

It is believed that this area and an area in Section 8 were used for outside storage for incendiary bombs during the late 1940's and early 1950's (Jones, et al, 1977). No release of contaminants has been reported in this area; therefore, no evaluation of this site was made.

4.13.11 Site 28, Section 4. Surface Disposal

Dirt piles next to Site 2 were dumped there between 1976 and 1981 as indicated by aerial photographs (see Figure 4-11). Since there are no reports of any contaminant being present, no evaluation of this site was made.

4.13.12 Site 29, Section 26. Pumping Pit

No documented information was found to evaluate the nature of the activity associated with the holding reservoir (pumping pit) located northeast of Basin F (see Figure 4-2). Unverified reports indicate that this reservoir was part of a sprinkler irrigation system which supplied water for irrigating wheat grown for the TX project. Presumably, the reservoir received fresh water from the Sand Creek lateral, fresh water stored in Basin C, and effluent from the sewage treatment plant located in Section 24 (Donnelly, personal communication, 1982).

No release of contaminants has been suspected at this site according to information reviewed; therefore, no evaluation was made of this site.

CHAPTER 5

CATEGORIZATION OF CONTAMINATION SOURCES

During Phase I, 32 potential contamination sources were divided into four groups based on the conditions likely to be encountered as determined by the literature search.

Implementation of the Technical Plan and the resultant review of chemical analysis has modified the grouping somewhat. The definition of the four groups remains the same:

- Group A - Contamination is present and known to be migrating
- Group B - Contamination is present, but migration is unknown
- Group C - The site has received possible contamination
- Group D - Site unlikely to have contaminants present

In the revised grouping, there is one site in Group A, six sites in Group B, twelve sites in Group C, and thirteen sites in Group D. Four sites were moved from Group B to Group C - sites 2, 3, 6 and 25. Site 16 went from Group C to Group D and Site 26 was moved from Group C to Group B.

Once the necessary information was available or could be estimated, an evaluation of each site having contamination present, which was known to be migrating or had the potential to migrate, was made by applying the Simplified Hazardous Site Ranking System developed in Phase I.

The scores established to categorize sites were determined by the factors used in developing the ranking system. Sites requiring immediate remedial action need a score in excess of

80 points. Sites where monitoring is recommended score between 50 and 80 points.

The cutoff score of 80 points to separate Category I and Category II reduces the possibility of including a hazardous site in Category I when migration potential is high but the toxicity of the contaminant is low or the level of the contaminant migrating is below the regulated standard. For sites introducing toxic contaminants to the environment, the travel time for migration off an installation must be short enough to preclude adequate time for implementing an appropriate remedial action program before the site can be ranked into the most severe category.

Results of the site evaluations for seven sites and classifying these potential contamination sites into either Category I or Category II are given in Table 5-1. Only Site

**TABLE 5-1
CATEGORY I AND II SITES FOR WHICH ADDITIONAL STUDY
AND/OR MONITORING IS RECOMMENDED,
ROCKY MOUNTAIN ARSENAL, DENVER, COLORADO**

Category	Site No.	Ranking Score	Site Use
I	11	97	DBCP source area in Section 3
II	26	78	GB Plant
II	24 & 30	69	Lake Dredge Disposal Area
II	9	61	New Toxic Storage Yard
II	4	56	Basins D and E
II	32	*	Section 36 Pits (Northeastward Migration)

* This site was not ranked. See Text.

11 has documented contamination migrating at a level above the regulated standard either at or near the Arsenal boundary in the groundwater system. Six sites were classified as Category II sites. Site 26 has contamination migrating at or near the Arsenal boundary, but the concentration is below the regulated standard. Contamination may also be migrating via the surface water system downgradient of Site 26. Two sites, Sites 24 and 30, were treated as one source area. Sites 9, 4, and 32 were the other three Category II sites. No ranking score was determined for Site 32 since no specific contamination was identified as migrating northeastward. However, due to the uncertain nature of the activities at Site 32 and the possibility that refinement of the hydrogeology in this area may alter suspected migration patterns, Site 32 was assigned a Category II classification. As additional data become available, an evaluation of the site will determine its final classification.

The remaining 25 sites listed in Table 5-1 are classified in Category III: sites which require no action at this time. The assignment of these sites into Category III relates only to the potential for migration of contaminants from these sites. The assessments given in this report are not intended to be indicative of the suitability of any given site for alternative land uses.

CHAPTER 6

CONCEPTUALIZED TECHNICAL PLAN FOR CONFIRMATORY STAGE

6.1 INTRODUCTION

Seven of the potential contamination sources described in Phase I have been designated Category I or II sites. Additional investigation or monitoring of the contamination at the seven sites is recommended by Geraghty & Miller, Inc. The recommended actions to be performed during the confirmatory stage will be given on a site-by-site basis.

6.2 CONCEPTUAL PLAN FOR SITE 11

Two main activities are proposed to confirm the probable location, magnitude, and migration rate of DBCP in the vicinity of the source area in Section 3. The two activities should be the installation of additional soil borings/monitoring wells and a complete review of data available on the distribution and migration of DBCP on Rocky Mountain Arsenal relative to the source area.

The first activity will be the installation of nine deep soil borings on a 50-foot grid spacing approximately centered where GM3-5 was drilled. These soil borings will penetrate at least 25 feet below the water table, with composite geologic samples from each ten foot interval for DBCP analysis. Additional samples may be taken in clayey zones for added definition. Replicate samples will be collected with one set of samples being subjected to solvent extraction

to determine the level of DBCP present in the soil. After reviewing laboratory results, a monitoring well should be installed at each location where DBCP contamination is suspected in the groundwater. If no contamination is expected in the groundwater, the soil boring will be backfilled.

For each geologic sample which has DBCP detected in the solvent extract, the replicate sample should be subjected to water extraction and subsequent analysis for DBCP. Three of the geologic samples which have DBCP detectable in the water leachates will be subjected to a repeat of the leaching procedure to indicate the possibility and magnitude of continued leaching.

The second activity will be a compilation and review of the available data on this DBCP problem collected by Rocky Mountain Arsenal, Waterways Experimental Station, and Shell Chemical. Time-concentration distributions of DBCP in the plume can be used in conjunction with analytical models to better define the parameters controlling the transport mechanisms.

The program of drilling and sampling will help estimate the size of the source area at the water table and what quantity of DBCP may be expected to reach the groundwater system. This information, together with the understanding obtained from the second activity, will be used to make predictions of DBCP migration from the source area.

Once the controlling transport parameters and the probable source function have been bracketed, it will be possible to

apply analytical or digital transport models to make predictions of DBCP migration in this area. Various control strategies, if required, can then be evaluated for remedial action.

6.3 CONCEPTUAL PLAN FOR SITE 26

The presence of DBCP in groundwater downgradient of the North Plant signals the migration of DIMP originating within the plant boundary. The extent of contamination in the groundwater system and the source of DIMP are not known, but need to be identified. Review of the physical operations relative to DIMP may indicate a specific source area and any mechanisms which may have transported the contamination, such as the sanitary sewer line.

It is recommended that a minimum of three groundwater monitoring wells be installed within the North Plant boundary to assist in source definition and the extent of contamination. The distribution of DIMP in the groundwater system in Section 24 north of the North Plant was presented in a previous report, but no source area suggested. Additional review of available data is needed to determine the present distribution of DIMP in this area. The reach of First Creek in Section 24 is a groundwater discharge zone at certain times and the groundwater system may already be contributing DIMP to the flow in First Creek. The presence of DIMP in the groundwater allows off-installation migration to occur in a relatively short time period. Resampling of selected monitoring wells and possibly surface waters in First Creek may be required. Hydrogeologic definition of the North Plant area is limited in terms of evaluating possible

source areas and contaminant migration.

6.4 CONCEPTUAL PLAN FOR SITES 24 & 30

No additional installation of monitoring wells is recommended at these sites in relation to contaminant migration via surface water or groundwater routes. The Dieldrin detected in a downgradient regional well probably originated in one of the south lakes, not from the lake dredge disposal areas. Migration by biological routes can represent a potential problem unless proper management practices are followed. Periodic review of water quality samples collected near Sites 24 and 30 will indicate any changes in conditions.

6.5 CONCEPTUAL PLAN FOR SITE 9

Several organic compounds were found in the surface water and soil below the new Toxic Storage Yard. Quantifications of these compounds will be necessary in order to assess the potential of contaminant migration in First Creek. No organic compounds have been detected in downgradient wells, but continued review of ongoing monitoring programs will indicate if contaminants begin to migrate via the groundwater system.

6.6 CONCEPTUAL PLAN FOR SITE 4

The presence of some CPMSO in a soil sample water extract from Basin E indicates the possibility of residual contamination at levels which may represent a migration potential. A review of groundwater quality upgradient and downgradient of these basins will assess whether or not

possible leaching of contaminants from the two basins is detectable in the groundwater system. If additional degradation of groundwater quality is deemed measurable, then additional soil samples should be taken in each basin to confirm residual contamination.

6.7 CONCEPTUAL PLAN FOR SITE 32

Although no degradation of the quality of groundwater moving northeast of Section 36 was detected, the water quality in the regional wells reviewed should be examined periodically to reassess possible contaminant migration. New hydrogeologic data may refine the knowledge of the groundwater flow system in this area, which may influence the monitoring points selected to assess the possible migration of contaminants from this site.

6.8 DEVELOPMENT OF A PHASE III TECHNICAL PLAN

Conceptual plans for confirmatory work to be completed in Stage II have been presented for the seven Category I and Category II sites. Specific recommendations were given for Site 11 and Site 26. It is recommended that a Phase III Technical Plan be formulated for these two sites. Development of a Phase III Technical Plan should be coordinated by Geraghty & Miller, Inc. and U.S. Army Toxic and Hazardous Materials Agency personnel with input to the program from Rocky Mountain Arsenal and Shell Chemical personnel.

Specific work plans for two of the four Category II sites, Site 9 and Site 4, can also be determined and included in the

Phase III Technical Plan. Recommendations for monitoring programs will be made during Stage II for Sites 24 & 30 and Site 32.

REFERENCES CITED

Aerial Photographs of Rocky Mountain Arsenal: 1493, 1948, 1949, 1949-50, 1950, 1953, 1955, 1958, 1964, 1965, 1966, 1970, 1972, 1973, 1974, 1976, 1979, 1980 and 1981.

Berry, Ed. Personal Communication, 1982.

Buxton, George. Personal Communication, 1982.

Cogley, David R., November, 1976. Report on UTSG Coring Data for Compounds at Rocky Mountain Arsenal, Submitted to U.S. Army Medical Bioengineering Research and Development Laboratory, Environmental Research Requirements Branch, Fort Detrick, Frederick, Maryland.

Donnelly, George F. Personal Communication, 1982.

Engineer Studies Group, January, 1975. Contaminated Area Clearance and Land-Use Alternatives, Office, Chief of Engineers, Department of the Army.

Gregg, Ron. Personal Communication, 1982.

Hurt, Robert K., March 4, 1974. Rocky Mountain Arsenal Demilitarization Report; Mustard Disposal and Air Monitoring Program at Rocky Mountain Arsenal.

Jones, Frank A. Jr., Wingfield, Damon A., and Byrne, John P., 1977. Installation Assessment of Rocky Mountain Arsenal, Colorado. Report No. 107, Vol. I, U.S. Army Toxic and Hazardous Materials Agency, Aberdeen Proving Ground, Maryland.

Kuznear, Casimir, and Trautmann, William L., 1980. History of Pollution Sources and Hazards at Rocky Mountain Arsenal, Rocky Mountain Arsenal, Denver, Colorado.

Lapalla, Eric G. and Stollar, Robert L., 1982. Recommended Ground-water Sampling Protocol and Monitoring Program for Rocky Mountain Arsenal, Denver, Colorado, Final Deliverable. Ertec Western, Long Beach, California. Under Contract to Battelle Columbus Laboratories, No. DAAG 29-81-D-0100, prepared for U.S. Army Toxic and Hazardous Materials Agency, Aberdeen Proving Ground, Maryland.

Moloney, William J., 1982. Assessment of Historical Waste Disposal in Section 36 of Rocky Mountain Arsenal, Preliminary Draft. Rocky Mountain Arsenal, Denver, Colorado.

Resource Consultants, Inc., 1982. Surface-Water Hydrologic Analyses, Rocky Mountain Arsenal, Denver, Colorado.

Romero, J.C., and Ward, G., 1981. "Water Table Contour Map of the Rocky Mountain Arsenal Region, Southwest Adams County, Colorado." Hydrologic Investigation Atlas HA-1. Colorado Division of Natural Resources.

Stollar, Robert L. and van der Leeden, Frits, 1981. Evaluation of the Hydrogeologic System and Contamination Migration Patterns, Rocky Mountain Arsenal, Denver, Colorado. Geraghty & Miller, Inc., Syosset, New York. Final Report for Contract No. DAAK 11-79-C-0148, prepared for U.S. Army Toxic and Hazardous Materials Agency, Aberdeen Proving Ground, Maryland.

U.S. Army Technical Escort Center, 1973. Army Material Command Contamination Survey, Rocky Mountain Arsenal, U.S. Army Technical Escort Center, Edgewood Arsenal, Aberdeen Proving Ground, Maryland.

Wullschleger, Richard, et al, August, 1981. Contaminant Leaching Investigation at Rocky Mountain Arsenal, Contract No. DAAK 11-79C-0114, Rexnord Inc., Environmental Research Center, Milwaukee, Wisconsin. Prepared for U.S. Army Toxic and Hazardous Materials Agency, Aberdeen Proving Ground, Maryland.

USATHAMA/Rocky Mountain Arsenal Project

Well No. 3-11Page 1 of 2Driller D'Appolonia Drilling Inc.Date 5/20/82Rig CME 55 AugerType of Sample Split SpoonHydrogeologist J. R. MildenbergerDiameter of Hole 6"

Sample No.	Blows Per 6 inches	Description	Sample Interval (ft)	
			From	To
	2-5-7	Fine sand, some silt, trace of medium sand, brown, moist (ML)	1.0	2.5
GS3-11A	3-6-8	Fine sand, silt, and clay, trace of medium sand, brown, moist (ML)	5.0	6.5
	7-7-7	Fine to medium sand, little silt, light brown, dry to moist (SW)	10.0	11.5
	7-9-10	Fine sand, little medium sand, trace of silt, light brown, dry (SP)	15.0	16.5
	9-10-11	Fine to coarse sand, trace of silt, light brown, dry (SW)	20.0	21.5
	7-8-11	Fine to medium sand, little coarse sand, trace of silt, light brown, dry to moist (SW)	25.0	26.5
	8-9-6	Same	30.0	31.5
	9-10-10	Fine to coarse sand, trace of silt, light brown, dry (SW)	35.0	36.5
	11-16-12	Fine to coarse sand, trace of silt and pebble, light brown, dry (SW)	40.0	41.5
	7-9-10	Fine to coarse sand grading downward to fine to medium sand, little clay, light brown, moist (SM/SW)	42.0	43.5
GS3-11B	7-8-9	Fine sand, little silt and clay, light brown, moist to dry (SM/SP)	45.0	46.5
	9-9-9	Fine sand, little medium sand, trace of silt, light brown, dry (SP)	50.0	51.5
	18-20-20	Fine to coarse sand, little clay and silt, light brown, moist (SM/SW)	55.0	56.5

USATHAMA/Rocky Mountain Arsenal Project

Well No. GM3-2 - BoringPage 1 of 2Driller D'Appolonia Drilling Inc.Date 5/18/82Rig CME 55 AugerType of Sample Split SpoonHydrogeologist J. R. MildenbergerDiameter of Hole 6"

Sample No.	Blows Per 6 inches	Description	Sample Interval (ft)	
			From	To
	4-4-5	Fine to medium sand, some silt, brown, moist (SM)	1.0	2.5
GS3-2A	4-4-6	Same	5.0	6.5
	4-7-10	Fine to medium sand, light brown, moist (SW)	10.0	11.5
	9-14-14	Fine to coarse sand, trace of silt and pebble, light brown, moist (SW)	15.0	16.5
	7-10-11	Same	20.0	21.5
	10-13-17	Fine to medium sand, little coarse sand, trace of silt, light brown, dry (SW)	25.0	26.5
	9-12-12	Same	30.0	31.5
	12-14-16	Same	35.0	36.5
GS3-2B	8-10-9	Silt and clay, little fine sand, brown, moist (CL)	40.0	41.5
	7-8-11	Same	45.0	46.5
	14-20-20	Fine to medium sand, trace of clay and silt, light brown, moist (SW)	50.0	51.5
	9-12-16	Fine to coarse sand, little clay, light brown, moist (SW)	55.0	56.5
	14-14-16	Fine to medium sand, trace of clay, light brown, moist (SW)	60.0	61.5

USATHAMA/Rocky Mountain Arsenal Project

Well No. GM3-4 - BoringPage 1 of 1Driller D'Appolonia Drilling, Inc.Date 5/18/82Rig CME 55 AugerType of Sample Split SpoonHydrogeologist J. R. MildenbergerDiameter of Hole 6 "

Sample No.	Blows Per 6 inches	Description	Sample Interval (ft)	
			From	To
GS3-4A	4-3-4	Fine to medium sand, little silt, light brown, moist (SW)	2.0	3.5
GS3-4A	4-5-5	Fine sand, some silt, little medium sand and clay, moist, light brown (ML)	5.0	6.5
GS3-4A	4-5-6	Fine to medium sand, light brown, moist (SW)	7.5	9.0
	3-4-4	Fine to medium sand, trace silt, light brown, moist (SW)	10.0	11.5
	4-7-9	Fine to medium sand, little silt and clay, light brown, moist Fine to medium sand, trace silt, light brown, moist (SW)	12.5	14.0
	4-9-12	Same	15.0	16.5
	7-12-15	Fine to medium sand, trace coarse sand and pebble, light brown, moist (SW)	17.5	19.0
	5-7-12	Fine to medium sand, little coarse sand and pebble, light brown, moist (SW)	20.0	21.5
	13-16-16	Fine to medium sand, little coarse sand, trace pebble and clay, light brown, moist (SW)	22.5	24.0
	8-12-10	Fine to coarse sand, trace clay and and pebble, light brown, moist (SW)	25.0	26.5

USATHAMA/Rocky Mountain Arsenal Project

Well No. GM3-5 - BoringPage 1 of 1Driller D'Appolonia Drilling Inc.Date 5/21/82Rig CME 55 AugerType of Sample Split SpoonHydrogeologist J. R. MildenbergerDiameter of Hole 6"

Sample No.	Blows Per 6 inches	Description	Sample Interval (ft)	
			From	To
GS3-5A	6-6-5	Fine to medium sand, little silt, brown, moist (ML/SM)	1.5	3.0
GS3-5A	4-2-2	Fine to medium sand, little silt, light brown, moist (SM)	5.0	6.5
GS3-5A	3-3-3	Fine sand, little clay, silt and medium sand (ML)	7.0	8.5
	11-14-16	Fine sand, trace of silt and medium sand, light brown, moist (SP)	25.0	26.5
	8-9-11	Fine to medium sand, little coarse sand, trace of pebble, silt, light brown, moist (SW)	30.0	31.5
	9-12-20	Fine sand, trace of medium sand and silt, light brown, moist (SP)	35.0	36.5
	12-15-20	Fine to coarse sand, trace of pebble, light brown, moist (SW)	40.0	41.5
GS3-5B	9-11-13	Fine to medium sand, light brown, moist (SW)	45.0	46.5
GS3-5B	9-11-10	Fine to medium sand, little clay and silt, brown, moist (SM/SW) with 2" lenses of clay and silt, trace of fine sand, brown, moist (CL)	47.5	49.0
GS3-5B	12-15-17	Fine to medium sand, trace of clay and and coarse sand, light brown, moist (SW)	49.0	50.5

Geraghty & Miller, Inc.

USATHAMA/Rocky Mountain Arsenal Project

Well No. 4-13

Page 1 of 2

Driller D'Appolonia Drilling Inc.

Date 5/13/82

Rig CME 55 Auger

Type of Sample Split Spoon

Hydrogeologist J. R. Mildenberger

Diameter of Hole 6"

Sample No.	Blows Per 6 inches	Description	Sample Interval (ft)	
			From	To
	4-7-7	Fine sand and silt, little organics, brown, dry (ML)	1.0	2.5
GS4-13A	4-6-5	Fine to medium sand, little silt, brown, dry (SM)	5.0	6.5
	3-5-7	Fine to coarse sand grading downward to fine sand, little silt, light brown, moist (SW/SM)	10.0	11.5
	4-8-7	Fine to medium sand, light brown, moist (SW)	15.0	16.5
	6-9-7	Same Clay and silt, trace fine sand, brown, moist (CL)	20.0	21.5
	5-7-12	Clay and silt, some fine to medium sand, brown moist (CL)	25.0	26.5
		Fine to medium sand, trace clay light brown, moist (SW)		
	4-4-5	Clay, little silt and fine sand, brown, moist (CL)	30.0	31.5
	5-8-13	Fine sand and clay, little silt, brown, moist (ML)	35.0	36.5
GS4-13B	9-8-9	Fine sand, little medium sand and silt, brown, moist (ML)	41.5	43.0
	10-8-9	Fine sand, little silt, light brown, moist (ML)	45.0	46.5
	16-20-25	Fine to medium sand, trace silt, light brown, moist (SW)	50.0	51.5

Geraghty & Miller, Inc.

USATHAMA/Rocky Mountain Arsenal Project

Well No. 4-14

Page 1 of 2

Driller D'Appolonia Drilling Inc.

Date 5/24/82

Rig Auger

Type of Sample Split Spoon

Hydrogeologist J. C. Rutledge

Diameter of Hole 6"

Sample No.	Blows Per 6 inches	Description	Sample Interval (ft)	
			From	To
	2-2-2	Silt and fine sand (ML)	1.0	2.5
GS4-14A	2-2-4	Fine sand, slightly silty 5.0-5.8' Silt, clayey and sandy 5.8-6.0' (ML)	5.0	6.5
	6-7-9	Fine-medium sand (SW)	10.0	11.5
	5-8-11	Fine-medium sand (SW)	15.0	16.5
	9-11-15	Fine-medium coarse sand (SW)	20.0	21.5
	8-11-13	Fine-medium sand to fine-coarse sand (SW)	25.0	26.5
	9-12-15	Fine-coarse sand, some gravel to fine-medium sand (SW)	30.0	31.5
GS4-14B	8-10-13	Fine-coarse sand (SW)	35.0	36.5
GS4-14B	8-15-13	Clay layer 36.5-36.7 Gravel and sand 36.7-36.9 Fine-medium sand (SW)	36.5	38.0
GS4-14B	5-6-10	Silt, some fine sand and clay (ML)	40.0	41.5
	5-8-11	Silt, slightly clayey (ML)	45.0	46.5
	9-11-15	Fine-medium sand, silt lenses (SM)	50.0	51.5
	12-12-20	Fine-medium sand, silt lens (SM)	55.0	56.5

Geraghty & Miller, Inc.

USATHAMA/Rocky Mountain Arsenal Project

Well No. 4-15

Page 1 of 2

Driller D'Appolonia Drilling Inc.

Date 5/26/82

Rig Auger

Type of Sample Split Spoon

Hydrogeologist J. C. Rutledge

Diameter of Hole 6"

Sample No.	Blows Per 6 inches	Description	Sample Interval (ft)	
			From	To
	6-13-12	Topsoil, fine sand, silty, slightly clayey 1.0-1.4' Silt, white 1.4-2.5' (ML)	1.0	2.5
	6-6-10	Medium fine-fine sand 5.0-5.5' (SW) Silt (white streaks) 5.5-5.8' (ML) Fine sand and silt 5.8-6.5' (SM)	5.0	6.5
	4-5-5	Fine-medium fine sand, interbedded silt (SM)	10.0	11.5
	4-8-12	Fine-coarse sand (SW)	15.0	16.5
	6-10-30	Fine-coarse sand 20.0-20.4' (SW) Clay, silt and sand 20.4-20.9' (CL) Gravel, sand, cobbles 20.9-21.5' (SP)	20.0	21.5
	11-13-15	Fine-coarse sand, some gravel to fine-medium sand (SW)	25.0	26.5
	8-11-12	Fine-medium sand to fine-coarse sand (SW)	30.0	31.5
	5-7-7	Silt and fine sand, sometimes clayey (SM)	35.0	36.5
	5-7-12	Silt, sometimes with clay (ML)	40.0	41.5
	6-8-10	Fine-medium fine sand 45.0-45.7' (SW) Silt 45.7-45.2' (ML) Clay 46.2-46.5' (CL)	45.0	46.5
	8-9-9	Fine-medium fine sand, some silt (SM)	50.0	51.5
	9-13-15	Fine-coarse sand, some gravel (SW)	55.0	56.5
	13-18-22	Fine-medium sand, some coarse sand and gravel (SW)	60.0	61.5

Geraghty & Miller, Inc.

USATHAMA/Rocky Mountain Arsenal Project

Well No. 30-12Page 1 of 1Driller D'Appolonia Drilling, Inc.Date 5/26/82Rig AugerType of Sample Split SpoonHydrogeologist J. C. RutledgeDiameter of Hole 6"

Sample No.	Blows Per 6 inches	Description	Sample Interval (ft)	
			From	To
	10-11-12	Silt, light brown and white, dry (ML)	1.0	2.5
	9-15-15	Silt, slightly clayey, white, dry (ML)	5.0	6.5
	5-15-23	Clay, silty, grey and white, dry (CL)	10.0	11.5
	15-20-30	Silt, clayey, white-grey, dry (ML)	15.0	15.5
	18-38-41	Silt, clayey, calcite, grey, orange stains, dry (ML)	20.0	21.5
	14-18-36	Clay, silty, grey, orange and white stain, slightly moist (CL)	25.0	26.5
	11-19-27	Silt, bright orange stain, greyish white (ML)	30.0	31.5
	75	Fine-medium sand, loose, slightly moist (SW)	32.5	33.0
	60	Fine-medium sand, loose, orange stain, slightly moist (SW)	35.0	35.5
	35-60	Fine-medium sand, yellow, moist (SW)	40.0	41.0
GS30-12A	40-50	Fine-medium fine sand, orange-brown, wet (SW)	45.0	46.0
	26-50	Same (SW)	50.0	51.0
		Clay, black, dense (OH)	55.0	55.5

Geraghty & Miller, Inc.

USATHAMA/Rocky Mountain Arsenal Project

Well No. 30-13

Page 1 of 1

Driller D'Appolonia Drilling Inc.

Date 5/27-28/82

Rig Auger

Type of Sample Split Spoon

Hydrogeologist J. C. Rutledge

Diameter of Hole 6 "

Sample No.	Blows Per 6 inches	Description	Sample Interval (ft)	
			From	To
	4-9-10	Topsoil - clay, silt and sand, light brown, slightly moist (ML) Silt, white, dry	1.0	2.5
	9-25-17	Silt, grey and white, slightly moist (ML)	5.0	6.5
	14-17-22	Silt, medium tan, iron staining, slightly moist (ML)	10.0	11.5
	11-20-30	Silt, tan, orange iron stain, dry (ML)	15.0	16.5
	11-9-15	Silt, clayey, grey, iron stain, dry Clay, gentonitic, white, slightly moist (OH)	20.0	21.5
	18-28-40	Clay, silty, white grey, slightly moist (OH)	25.0	26.5
	17-35-50	Silt, clayey, tan, grey, iron stain, dry (ML)	30.0	31.5
	75	Fine sand, silty, tan, slightly moist (ML)	35.0	35.5
	40-75/3"	Fine sand, silty, light brown, slightly moist (ML)	40.0	41.0
	35-75/4"	Fine-medium sand, brown, moist (SW)	45.0	46.0
	35-45-53	Fine-medium sand, brown, iron stain wet (SW)	50.0	51.5
	35-65	Same (SW)	55.0	56.0
	6-50-75/3"	Same (SW)	60.0	61.5

EVALUATING A HAZARDOUS SITE WITH THE GERAGHTY & MILLER, INC.
SIMPLIFIED HAZARDOUS SITE RANKING SYSTEM

A hazardous site can have numerous contaminants present which may or may not migrate by any of four possible routes. The worst case scenario is used to determine the final score for a hazardous site. It may be necessary to make several evaluations of each site for different contaminants and different routes to identify the worst case.

SOURCE CHARACTERISTIC EVALUATION

Factors which must be evaluated in the source characteristics category fall into two subcategories - temporal or spatial. Temporal considerations deal only with the time in years since the start of contamination. One point is assigned for each decade, with a maximum of four points allowed.

Spatial considerations are divided into four different factors. The first factor identifies how the contaminant was introduced into the environment. A higher value (three points) is assigned to a non-containerized activity versus one point for when the contaminant is containerized. The next factor reflects the area over which the contaminant was introduced. The user must take into account the possible volume of contaminant introduced and the area in which the activity took place. If the activity is considered to be concentrated areally, then it is assigned three points. If not, the contaminant is considered to be dispersed areally and two points are assigned. The physical state of the contaminant is the next factor. Liquid and gaseous wastes are assigned three points while solid wastes are given two points. The last factor affecting the spatial considerations assigns a value of two points if the contaminant is placed below ground versus one point if placed above ground.

WASTE CHARACTERISTICS EVALUATION

Three factors define the waste characteristics--toxicity, persistence, and attenuation. Toxicity values range from one point for low toxicity to 20 points for high toxicity. Possible concentrations of the contaminant in the transportation medium may need to be taken into account when assigning a toxicity rating. The acute versus chronic toxicity factors may lead to different ratings. Persistence reflects the expected life of the contaminant in its present environment. Assigned values can range from two to six points. The third factor, attenuation, is a function of the contaminant's mobility, solubility, and sorption. Several references now list specific information on many chemicals which can be used as guidelines in evaluating this factor. However, as noted earlier, there are very limited data on synergistic relationships between chemicals which can greatly affect mobility. The expertise of the project team is important in assigning a value to the attenuation factor, which can range in value from one to nine points.

ROUTE CHARACTERISTICS EVALUATION

The most important of the three categories is the route characteristics category, which accounts for one-half of the maximum possible score assigned to a hazardous site. The route category is divided into four subcategories. Three subcategories identify different routes by which a contaminant can migrate - a surface water route, a groundwater route, or an air route. The fourth subcategory defines the mechanism associated with direct contact of a contaminant.

The surface water route represents the potential for a contaminant to migrate great distances in a short time. Three factors, either separately or in combination, can be part of the surface water route.

The first factor, a contemporaneous stream means streamflow and contamination occur simultaneously. The relationship between streamflow characteristics and the quantity of contaminant introduced to the stream must be considered to ascertain the severity of the conditions before a factor score is assigned. Fifty points is also the maximum possible score for the other two factors - lakes or ponds and ephemeral streams. The evaluation of each factor must take into account pertinent characteristics of the route in relation to the quantity of the contaminant introduced. With the introduction of contaminants into the surface water system, particularly lakes or ponds, the user must take into account the possibility of the contaminant entering various food chains which may ultimately result in human consumption. If a combination of two or three factors is used, the aggregate total cannot exceed the maximum points for the route characteristics category, that being 50 points.

In evaluating the groundwater route, the factor considered is travel time required for a contaminant to migrate off an installation. The two dependent variables of travel time - distance and velocity - are incorporated into travel time. Travel time includes allowances for unsaturated flow as well as saturated flow. Discussions with the U.S. Army Toxic and Hazardous Materials Agency have established that if groundwater migration of a contaminant off the Arsenal is possible in less than 20 years, then this situation represents a high priority for making management decisions. Travel time in excess of 20 years permits time for monitoring and further evaluation. The range of points allowed for different travel times for a contaminant to migrate in the groundwater system is shown in Figure 2-1. The expertise of the project team is quite important in evaluating mass transport considerations and chemical synergism on contaminant travel time.

Like the surface water route, the air route represents the potential for a contaminant to migrate great distances in a short time. Two factors characterize the air route and both are worth a maximum of 50 points. The factors represent two types of releases--controlled and uncontrolled. Incineration or manufacturing processes are types of controlled releases, while fires, explosions, and dust storms would be types of uncontrolled releases. Certain contaminants are readily adsorbed into soil particles and may persist in the soil for a long time. This contaminated soil may be subject to considerable wind erosion and transport given the arid environment of Rocky Mountain Arsenal and the occurrence of high winds. Atmospheric dispersion and diffusion of the contaminated particulate matter generally dilute the concentration many orders of magnitude within a few miles from the source. Again, the expertise of the project team is an essential part of evaluating the possible severity of this route.

The last subcategory is the direct contact mechanism. This involves contact exposure to a contaminant that is unassociated with any other route. Direct contact can occur to the contaminant directly or to some medium that has been contaminated, e.g. soil or water. The route has a possible maximum score of 50 points. The known presence of unexploded ordnance at a site results in a maximum score for direct contact.

SIMPLIFIED HAZARDOUS SITE RANKING SYSTEM

Site 11 Chemical DBCP Section No. 3
 (Circle Factor Value Selected)

I. Source Characteristics (15 pts maximum).....12

- A. Temporal Considerations..... 2
1. The start of contamination
 - Fewer than 10 years ago (1 pt)
 - Between 10 and 20 years ago (2 pts)
 - Between 20 and 30 years ago (3 pts)
 - More than 30 years ago (4 pts)
- B. Spatial Considerations..... 10
1. Containerized (1 pt) Non-containerized (3 pts)
 2. Dispersed areally (2 pts) Concentrated areally (3 pts)
 3. Solid waste (2 pts) Liquid/gaseous waste (3 pts)
 4. Deposited below ground (2 pts) Above ground (1 pt)

II. Waste Characteristics (35 pts maximum).....35

	Low	Medium	High
A. Toxicity.....	1 pt	10 pts	<u>20 pts</u>
B. Persistence.....	2 pts	4 pts	<u>6 pts</u>
C. Attenuation.....	<u>9 pts</u>	5 pts	1 pt

III. Route Characteristics (50 pts maximum).....50
 (Evaluate all routes, select highest score)

- A. Surface Water Route..... 0
1. Contemporaneous stream (0 - 50 pts)
 2. Lake/pond (0 - 50 pts)
 3. Ephemeral stream (0 - 50 pts)
- B. Groundwater Route..... 50
1. Short travel time (0 - 10 yrs) (41 - 50 pts)
 2. Medium travel time (10 - 20 yrs) (31 - 40 pts)
 3. Long travel time (more than 20 yrs) (0 - 30 pts)
- C. Air Route..... 0
1. Controlled release (incineration) (0 - 50 pts)
 2. Uncontrolled release (fire, dust, etc.) (0 - 50 pts)
- D. Direct Contact Route..... 0 (0 - 50 pts)
 (unassociated with other routes)

TOTAL: (100 pts maximum).....97*

* Ranked July 1982.

SIMPLIFIED HAZARDOUS SITE RANKING SYSTEM

Site 26 Chemical DIMP Section No. 25
 (Circle Factor Value Selected)

I. Source Characteristics (15 pts maximum).....14

- A. Temporal Considerations..... 3
- 1. The start of contamination
 - Fewer than 10 years ago (1 pt)
 - Between 10 and 20 years ago (2 pts)
 - Between 20 and 30 years ago (3 pts)
 - More than 30 years ago (4 pts)
- B. Spatial Considerations..... 11
- 1. Containerized (1 pt) Non-containerized (3 pts)
 - 2. Dispersed areally (2 pts) Concentrated areally (3 pts)
 - 3. Solid waste (2 pts) Liquid/gaseous waste (3 pts)
 - 4. Deposited below ground (2 pts) Above ground (1 pt)

II. Waste Characteristics (35 pts maximum)..... 14

- | | Low | Medium | High |
|---------------------------------|-------|--------------|--------|
| A. Toxicity..... <u>5</u> | 1 pt | 10 pts | 20 pts |
| B. Persistence..... <u> </u> | 2 pts | <u>4 pts</u> | 6 pts |
| C. Attenuation..... <u> </u> | 9 pts | <u>5 pts</u> | 1 pt |

III. Route Characteristics (50 pts maximum).....50
 (Evaluate all routes, select highest score)

- A. Surface Water Route..... 50
- 1. Contemporaneous stream (0 - 50 pts)
 - 2. Lake/pond (0 - 50 pts)
 - 3. Ephemeral stream (0 - 50 pts)
- B. Groundwater Route..... 50
- 1. Short travel time (0 - 10 yrs) (41 - 50 pts)
 - 2. Medium travel time (10 - 20 yrs) (31 - 40 pts)
 - 3. Long travel time (more than 20 yrs) (0 - 30 pts)
- C. Air Route..... 0
- 1. Controlled release (incineration) (0 - 50 pts)
 - 2. Uncontrolled release (fire, dust, etc.) (0 - 50 pts)
- D. Direct Contact Route..... 0
 (unassociated with other routes) (0 - 50 pts)

TOTAL: (100 pts maximum).....78 *

* Ranked July 1982.

SIMPLIFIED HAZARDOUS SITE RANKING SYSTEM

Site 24~~E~~30 Chemical DIELDRIIN Section No. 11~~E~~12
 (Circle Factor Value Selected)

I. Source Characteristics (15 pts maximum).....12

- A. Temporal Considerations..... 2
1. The start of contamination
 - Fewer than 10 years ago (1 pt)
 - Between 10 and 20 years ago (2 pts)
 - Between 20 and 30 years ago (3 pts)
 - More than 30 years ago (4 pts)
- B. Spatial Considerations..... 10
1. Containerized (1 pt) Non-containerized (3 pts)
 2. Dispersed areally (2 pts) Concentrated areally (3 pts)
 3. Solid waste (2 pts) Liquid/gaseous waste (3 pts)
 4. Deposited below ground (2 pts) Above ground (1 pt)

II. Waste Characteristics (35 pts maximum).....27

	Low	Medium	High
A. Toxicity.....	1 pt	10 pts	20 pts
B. Persistence.....	2 pts	4 pts	6 pts
C. Attenuation.....	9 pts	5 pts	1 pt

III. Route Characteristics (50 pts maximum).....30
 (Evaluate all routes, select highest score)

- A. Surface Water Route..... 30
1. Contemporaneous stream (0 - 50 pts)
 2. Lake/pond (0 - 50 pts)
 3. Ephemeral stream (0 - 50 pts)
- B. Groundwater Route..... 20
1. Short travel time (0 - 10 yrs) (41 - 50 pts)
 2. Medium travel time (10 - 20 yrs) (31 - 40 pts)
 3. Long travel time (more than 20 yrs) (0 - 30 pts)
- C. Air Route..... 0
1. Controlled release (incineration) (0 - 50 pts)
 2. Uncontrolled release (fire, dust, etc.) (0 - 50 pts)
- D. Direct Contact Route..... 5 (0 - 50 pts)
 (unassociated with other routes)

TOTAL: (100 pts maximum).....69 *

* Ranked July 1982.

SIMPLIFIED HAZARDOUS SITE RANKING SYSTEM

Site 9 Chemical DCPD derivative Section No. 31
 (Circle Factor Value Selected)

I. Source Characteristics (15 pts maximum).....12

A. Temporal Considerations..... 2

1. The start of contamination
 - Fewer than 10 years ago (1 pt)
 - Between 10 and 20 years ago (2 pts)
 - Between 20 and 30 years ago (3 pts)
 - More than 30 years ago (4 pts)

B. Spatial Considerations..... 10

1. Containerized (1 pt) Non-containerized (3 pts)
2. Dispersed areally (2 pts) Concentrated areally (3 pts)
3. Solid waste (2 pts) Liquid/gaseous waste (3 pts)
4. Deposited below ground (2 pts) Above ground (1 pt)

II. Waste Characteristics (35 pts maximum).....19

	Low	Medium	High
A. Toxicity.....	1 pt	10 pts	20 pts
B. Persistence.....	2 pts	4 pts	6 pts
C. Attenuation.....	9 pts	5 pts	1 pt

III. Route Characteristics (50 pts maximum).....30
 (Evaluate all routes, select highest score)

A. Surface Water Route..... 30

1. Contemporaneous stream (0 - 50 pts)
2. Lake/pond (0 - 50 pts)
3. Ephemeral stream (0 - 50 pts)

B. Groundwater Route..... 20

1. Short travel time (0 - 10 yrs) (41 - 50 pts)
2. Medium travel time (10 - 20 yrs) (31 - 40 pts)
3. Long travel time (more than 20 yrs) (0 - 30 pts)

C. Air Route..... 0

1. Controlled release (incineration) (0 - 50 pts)
2. Uncontrolled release (fire, dust, etc.) (0 - 50 pts)

D. Direct Contact Route..... 0 (0 - 50 pts)
 (unassociated with other routes)

TOTAL: (100 pts maximum).....61*

* Ranked July 1982.

SIMPLIFIED HAZARDOUS SITE RANKING SYSTEM

Site 4 Chemical CPMSO Section No. 26
 (Circle Factor Value Selected)

I. Source Characteristics (15 pts maximum).....12

A. Temporal Considerations..... 2

1. The start of contamination
 - Fewer than 10 years ago (1 pt)
 - Between 10 and 20 years ago (2 pts)
 - Between 20 and 30 years ago (3 pts)
 - More than 30 years ago (4 pts)

B. Spatial Considerations..... 10

1. Containerized (1 pt) Non-containerized (3 pts)
2. Dispersed areally (2 pts) Concentrated areally (3 pts)
3. Solid waste (2 pts) Liquid/gaseous waste (3 pts)
4. Deposited below ground (2 pts) Above ground (1 pt)

II. Waste Characteristics (35 pts maximum).....14

	Low	Medium	High
A. Toxicity.....	<u>1 pt</u>	10 pts	20 pts
B. Persistence.....	2 pts	<u>4 pts</u>	6 pts
C. Attenuation.....	<u>9 pts</u>	5 pts	1 pt

III. Route Characteristics (50 pts maximum).....30
 (Evaluate all routes, select highest score)

A. Surface Water Route..... 0

1. Contemporaneous stream (0 - 50 pts)
2. Lake/pond (0 - 50 pts)
3. Ephemeral stream (0 - 50 pts)

B. Groundwater Route..... 30

1. Short travel time (0 - 10 yrs) (41 - 50 pts)
2. Medium travel time (10 - 20 yrs) (31 - 40 pts)
3. Long travel time (more than 20 yrs) (0 - 30 pts)

C. Air Route..... 0

1. Controlled release (incineration) (0 - 50 pts)
2. Uncontrolled release (fire, dust, etc.) (0 - 50 pts)

D. Direct Contact Route..... 0 (0 - 50 pts)
 (unassociated with other routes)

TOTAL: (100 pts maximum).....56*

* Ranked July 1982.

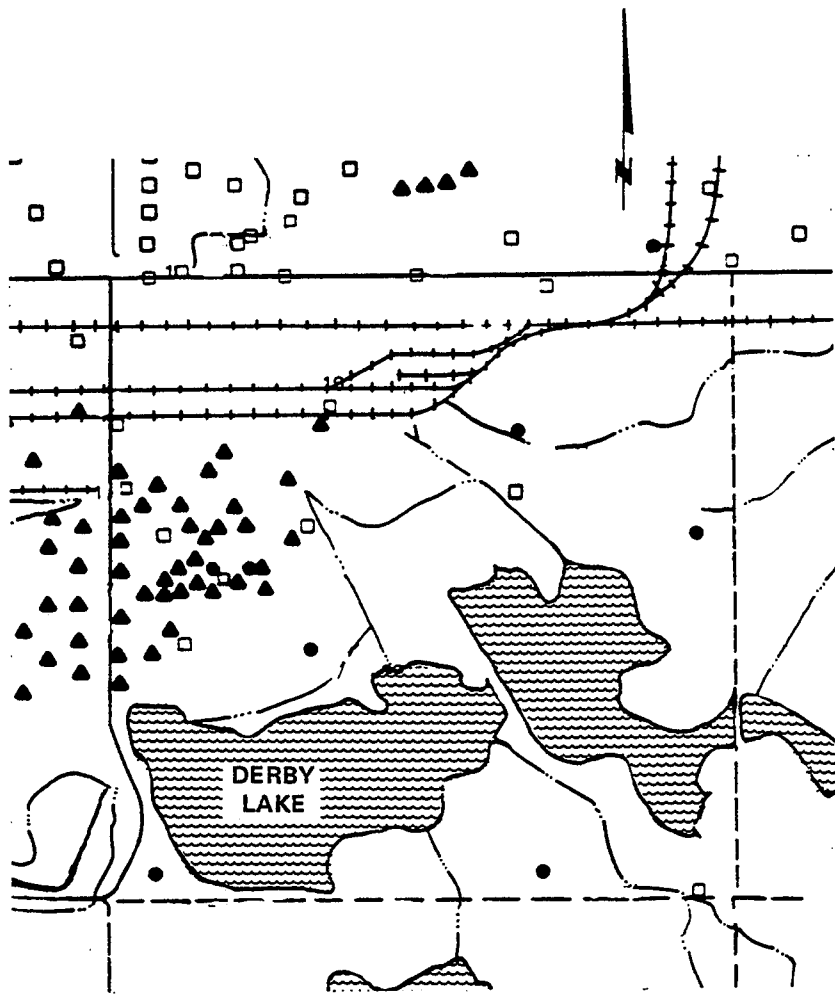

LEGEND

SECTION 1

SERIES A MAPS



LINE OF CROSS SECTION



SURFACE STORAGE/DISPOSAL



BASIN/PIT DISPOSAL



NWI REGIONAL WELL



SHELL CHEMICAL WELL



OTHER WELL

**SERIES A
LOCATION OF BORINGS AND
LINE OF SECTION**

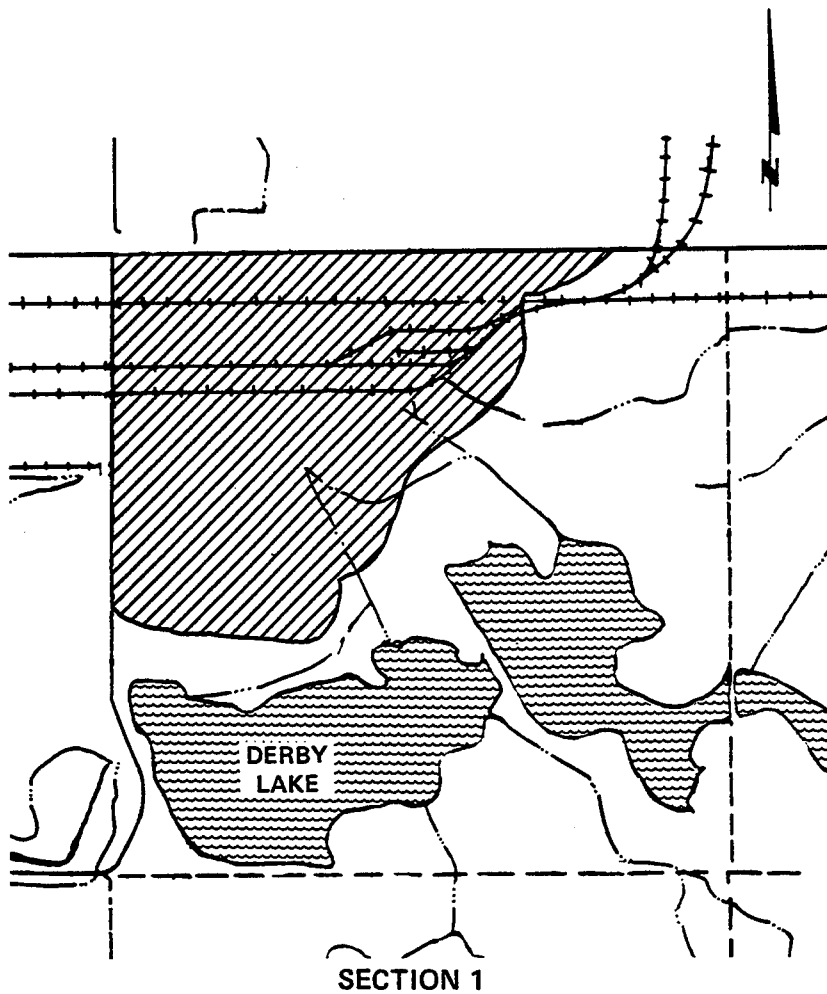

LEGEND

SERIES C MAPS



LATERAL EXTENT OF PLUME, IF PRESENT



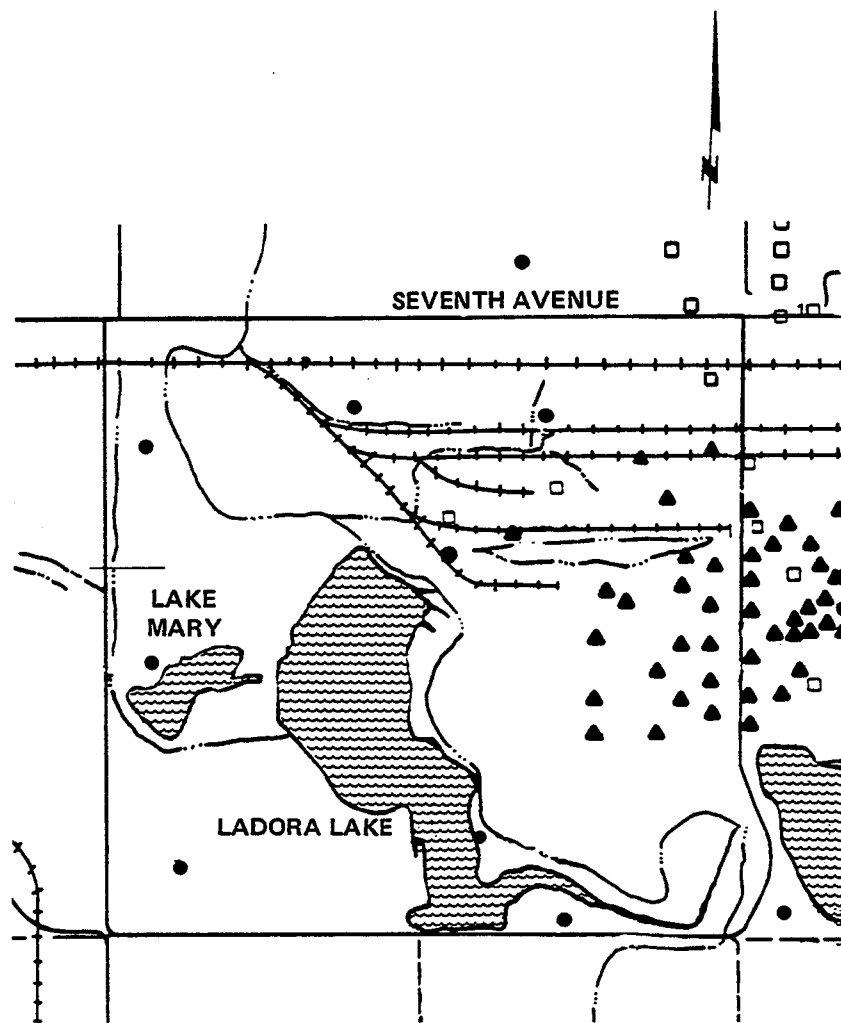



**SERIES C
ABANDONED FARM WELLS AND
CONTAMINANT PLUME**



SECTION 2

LEGEND

SERIES A MAPS

- | | |
|---|--------------------------|
|  | LINE OF CROSS SECTION |
|  | SURFACE STORAGE/DISPOSAL |
|  | BASIN/PIT DISPOSAL |
|  | NWI REGIONAL WELL |
|  | SHELL CHEMICAL WELL |
|  | OTHER WELL |

SERIES A
LOCATION OF BORINGS AND
LINE OF SECTION

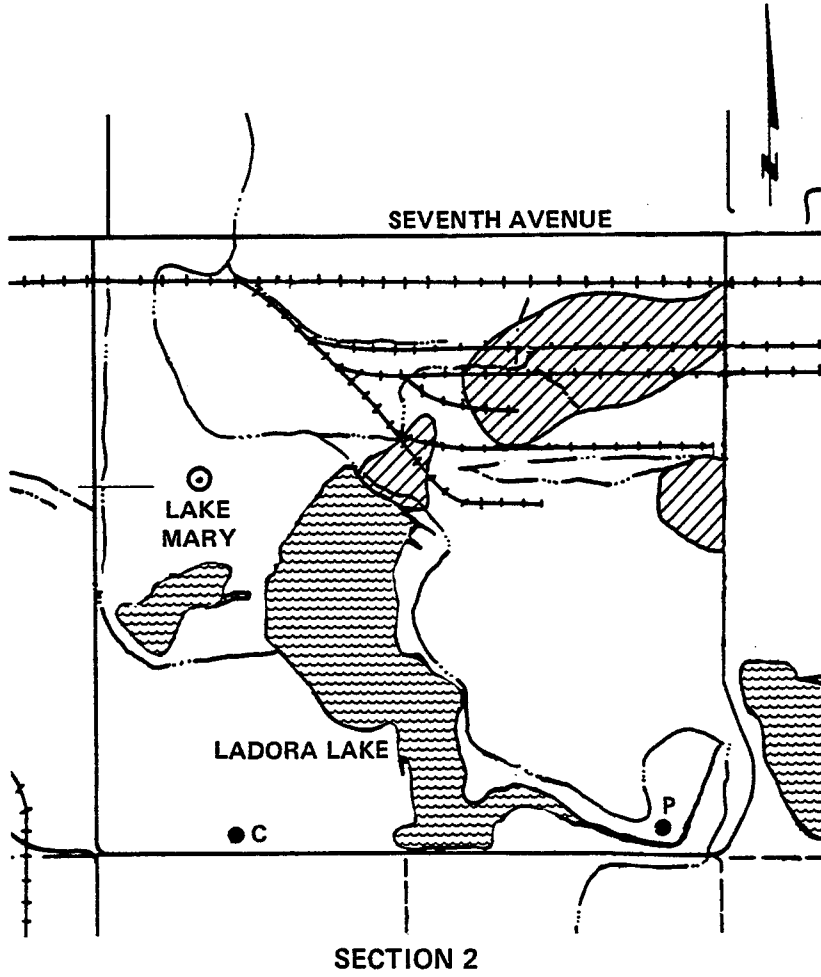

LEGEND

SERIES C MAPS

- P SHALLOW ABANDONED FARM WELL, PLUGGED
- C SHALLOW ABANDONED FARM WELL, CAPPED
- ⊙ DEEP ABANDONED FARM WELL
- ▨ LATERAL EXTENT OF PLUME, IF PRESENT

**SERIES C
ABANDONED FARM WELLS AND
CONTAMINANT PLUME**

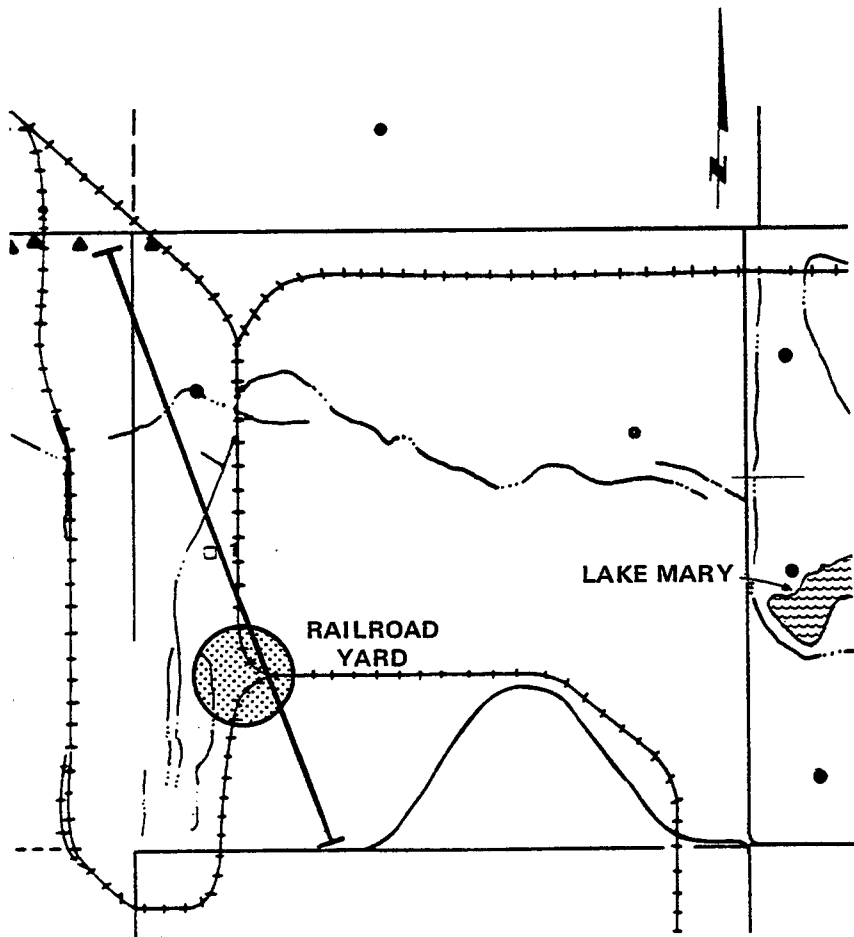

SECTION 3

LEGEND

SERIES A MAPS



LINE OF CROSS SECTION



SURFACE STORAGE/DISPOSAL



BASIN/PIT DISPOSAL



NWI REGIONAL WELL



SHELL CHEMICAL WELL



OTHER WELL

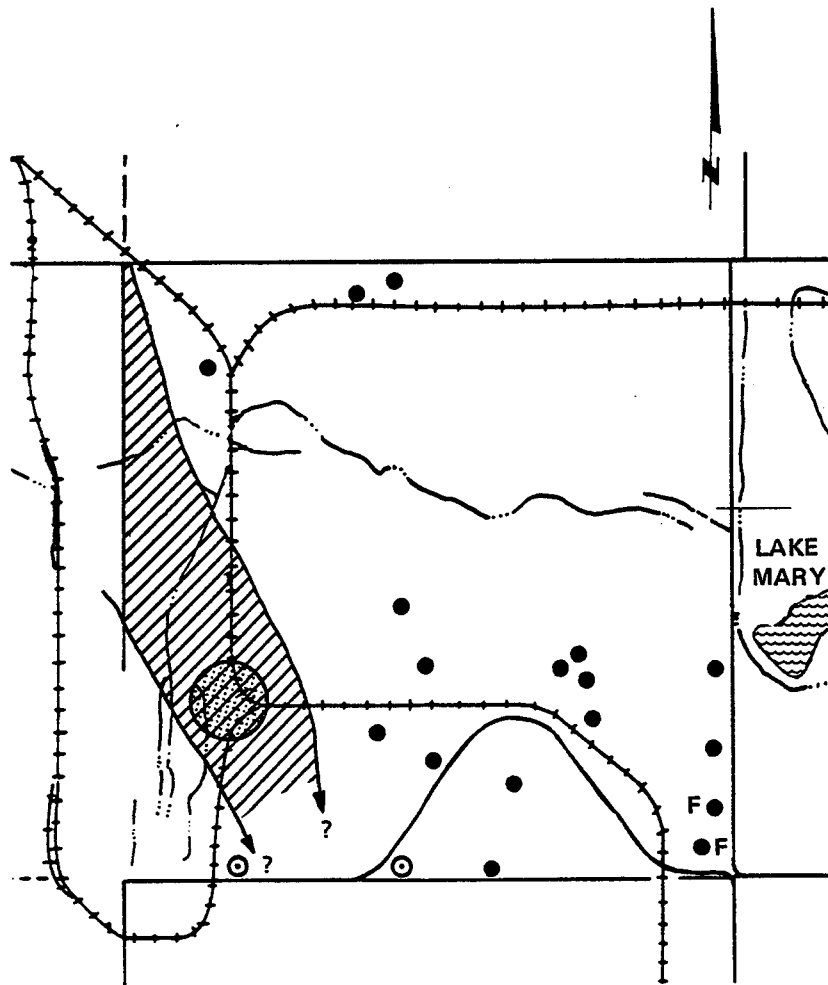

SERIES A
LOCATION OF BORINGS AND
LINE OF SECTION



SECTION 3

LEGEND

SERIES C MAPS

- SHALLOW ABANDONED FARM WELL
- F SHALLOW ABANDONED FARM WELL, FILLED
- ⊙ DEEP ABANDONED FARM WELL
-  LATERAL EXTENT OF PLUME, IF PRESENT
-  SURFACE STORAGE/DISPOSAL

SERIES C
 ABANDONED FARM WELLS AND
 CONTAMINANT PLUME

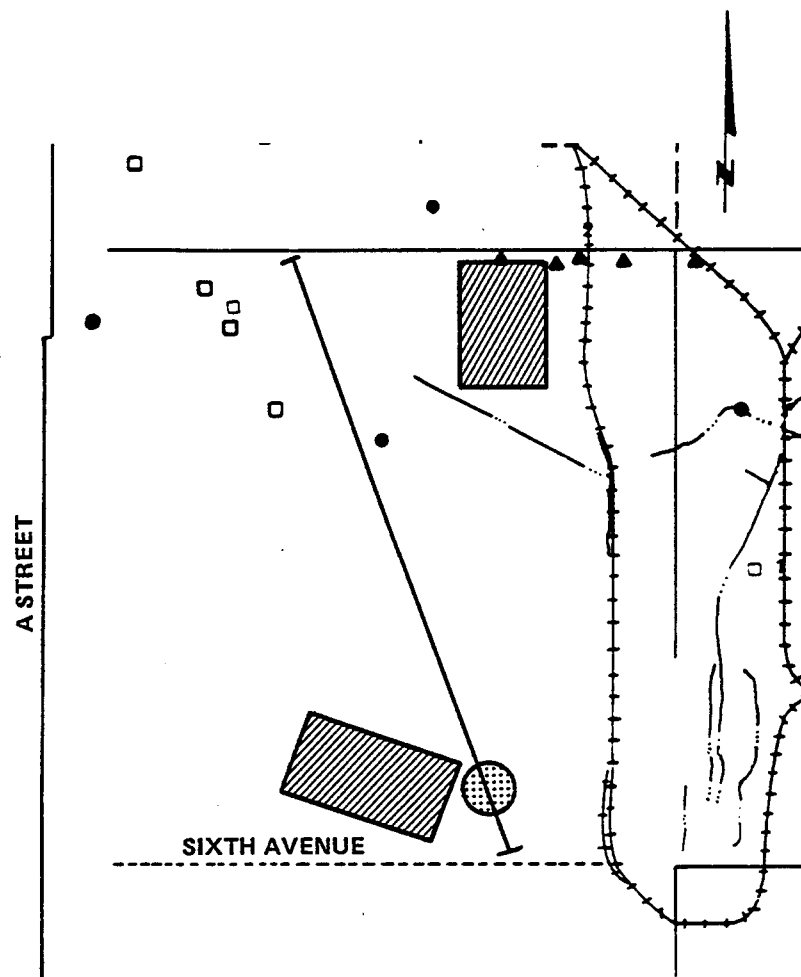

SECTION 4

LEGEND

SERIES A MAPS



LINE OF CROSS SECTION



SURFACE STORAGE/DISPOSAL



BASIN/PIT DISPOSAL



NWI REGIONAL WELL



SHELL CHEMICAL WELL



OTHER WELL

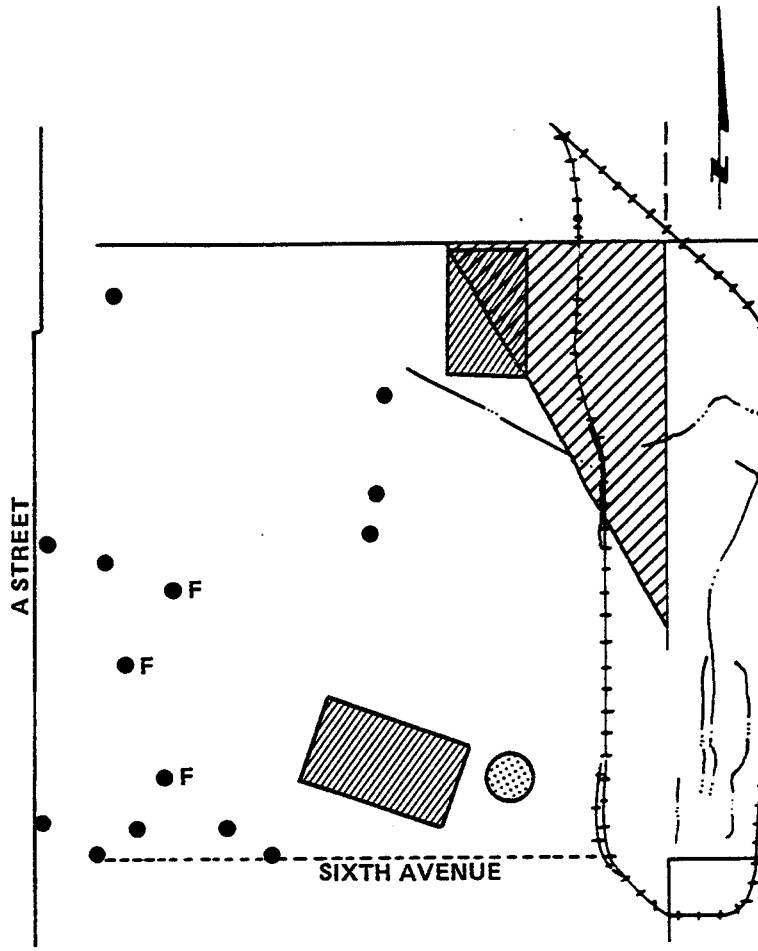

**SERIES A
LOCATION OF BORINGS AND
LINE OF SECTION**



SECTION 4

LEGEND

SERIES C MAPS

- SHALLOW ABANDONED FARM WELL
- F SHALLOW ABANDONED FARM WELL, FILLED
-  LATERAL EXTENT OF PLUME, IF PRESENT
-  BASIN/PIT DISPOSAL
-  SURFACE STORAGE/DISPOSAL

SERIES C
ABANDONED FARM WELLS AND
CONTAMINANT PLUME

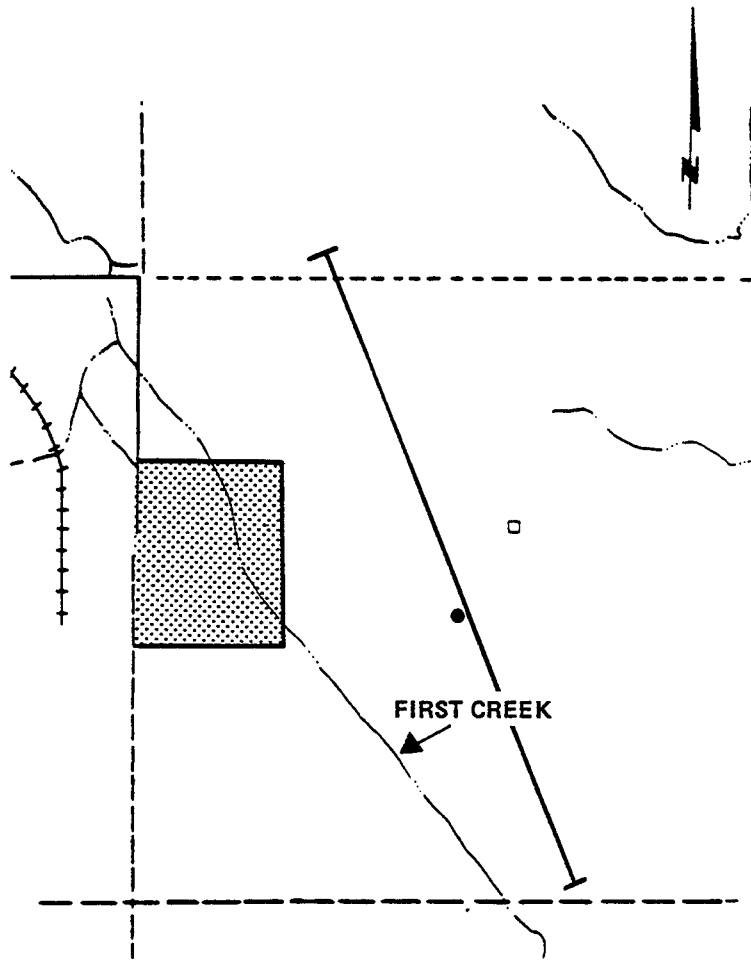

SECTION 5

LEGEND

SERIES A MAPS



LINE OF CROSS SECTION



SURFACE STORAGE/DISPOSAL



BASIN/PIT DISPOSAL



NWI REGIONAL WELL



SHELL CHEMICAL WELL



OTHER WELL

**SERIES A
LOCATION OF BORINGS AND
LINE OF SECTION**

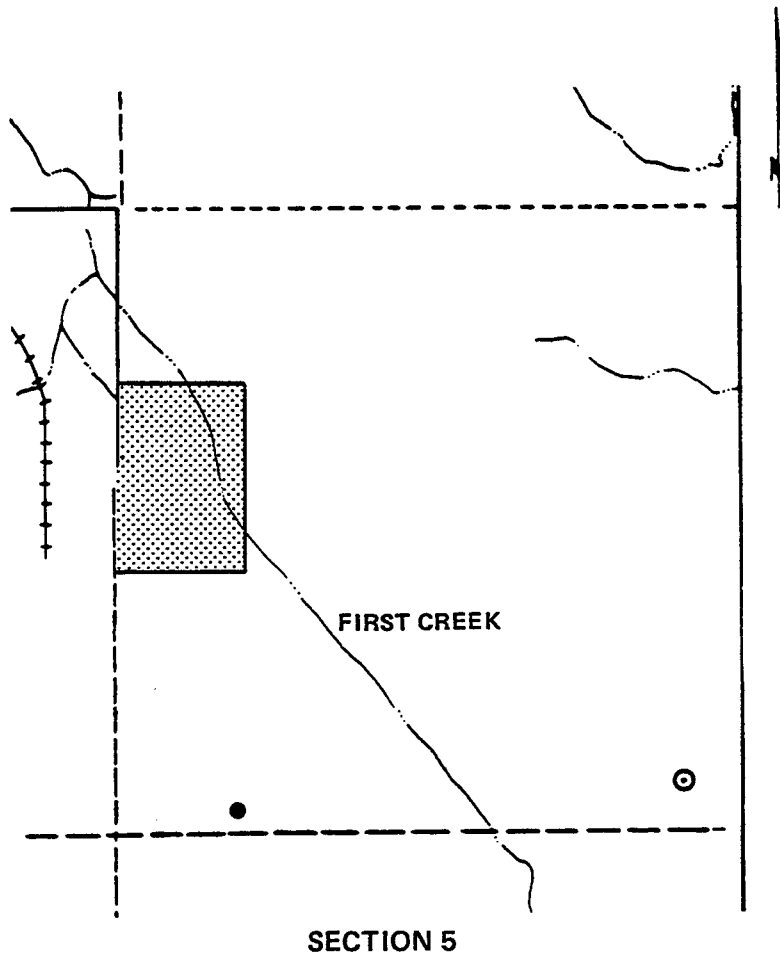

LEGEND

SERIES C MAPS

- SHALLOW ABANDONED FARM WELL
- ⊙ DEEP ABANDONED FARM WELL
- ▨ SURFACE STORAGE/DISPOSAL

**SERIES C
ABANDONED FARM WELLS AND
CONTAMINANT PLUME**

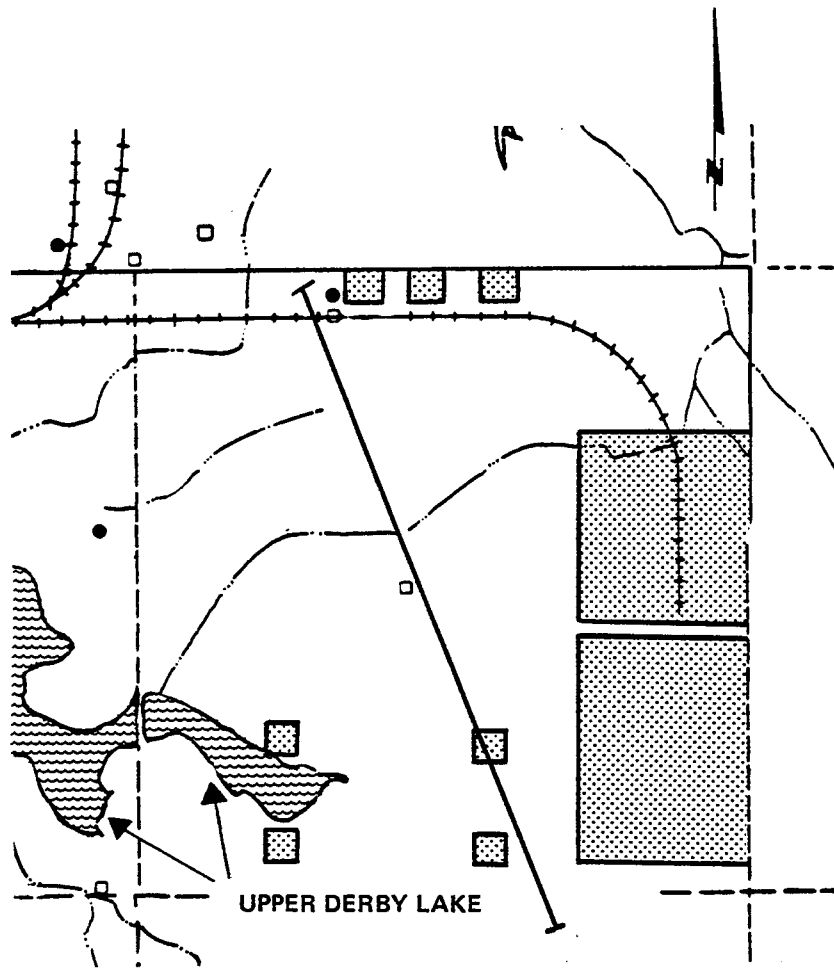

SECTION 6

LEGEND

SERIES A MAPS



LINE OF CROSS SECTION



SURFACE STORAGE/DISPOSAL



BASIN/PIT DISPOSAL



NWI REGIONAL WELL



SHELL CHEMICAL WELL



OTHER WELL

**SERIES A
LOCATION OF BORINGS AND
LINE OF SECTION**

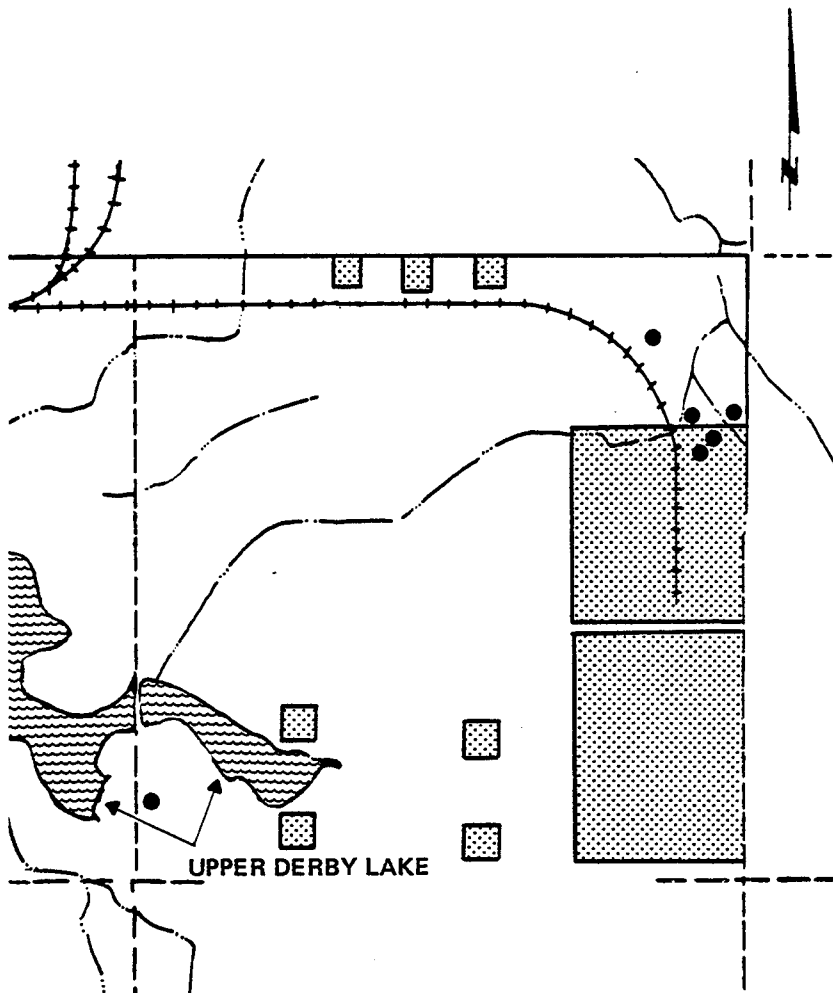

SECTION 6

LEGEND

SERIES C MAPS

- SHALLOW ABANDONED FARM WELL
-  SURFACE STORAGE/DISPOSAL



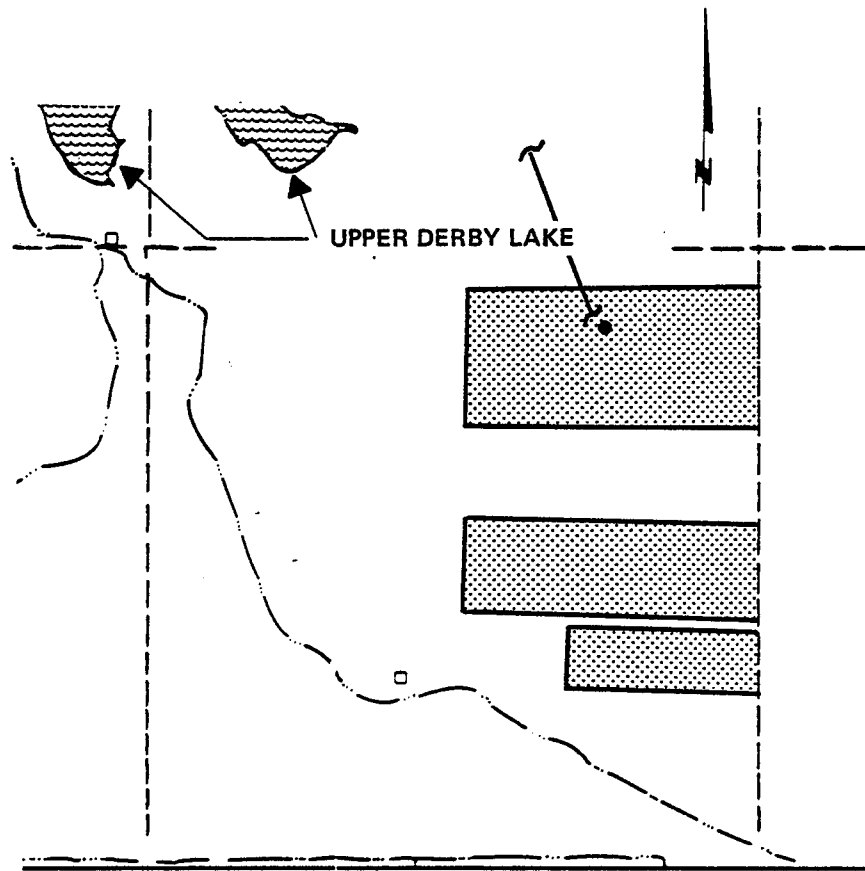



SERIES C
 ABANDONED FARM WELLS AND
 CONTAMINANT PLUME



SECTION 7

LEGEND

SERIES A MAPS

- | | |
|---|--------------------------|
|  | LINE OF CROSS SECTION |
|  | SURFACE STORAGE/DISPOSAL |
|  | BASIN/PIT DISPOSAL |
|  | NWI REGIONAL WELL |
|  | SHELL CHEMICAL WELL |
|  | OTHER WELL |

SERIES A
LOCATION OF BORINGS AND
LINE OF SECTION

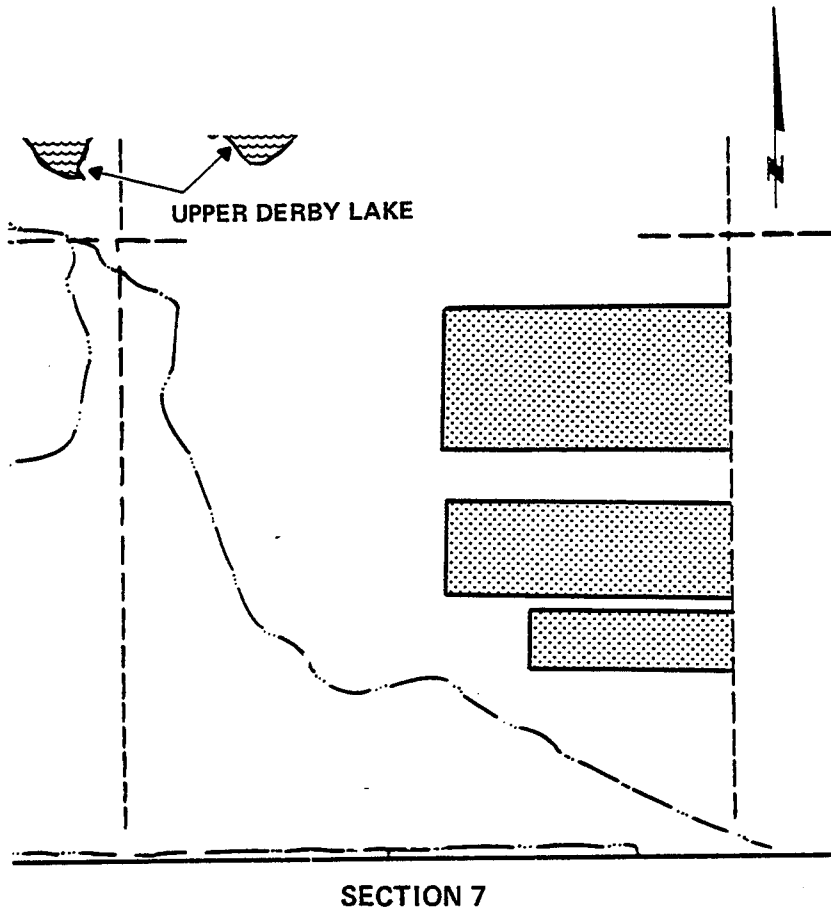

LEGEND

SERIES C MAPS



SURFACE STORAGE/DISPOSAL



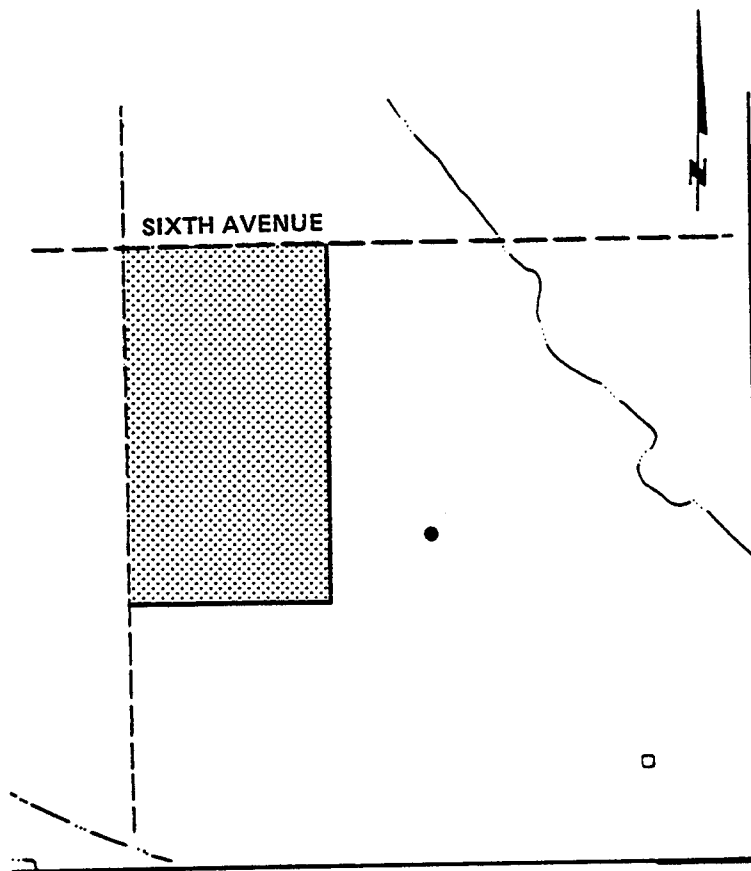



**SERIES C
ABANDONED FARM WELLS AND
CONTAMINANT PLUME**



SECTION 8

LEGEND

SERIES A MAPS

-  **LINE OF CROSS SECTION**
-  **SURFACE STORAGE/DISPOSAL**
-  **BASIN/PIT DISPOSAL**
-  **NWI REGIONAL WELL**
-  **SHELL CHEMICAL WELL**
-  **OTHER WELL**

**SERIES A
LOCATION OF BORINGS AND
LINE OF SECTION**

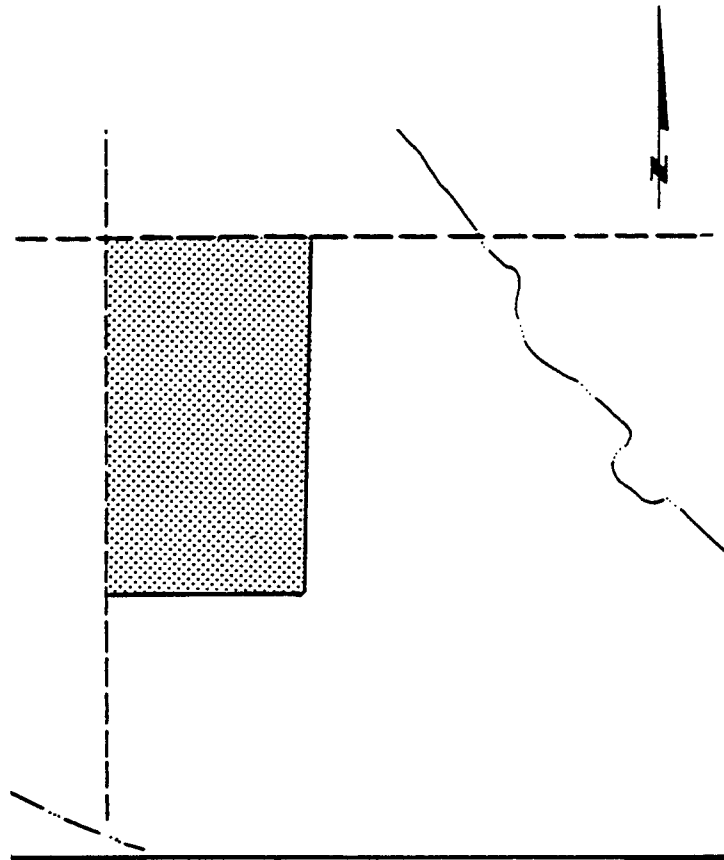

SECTION 8

LEGEND

SERIES C MAPS



SURFACE STORAGE/DISPOSAL



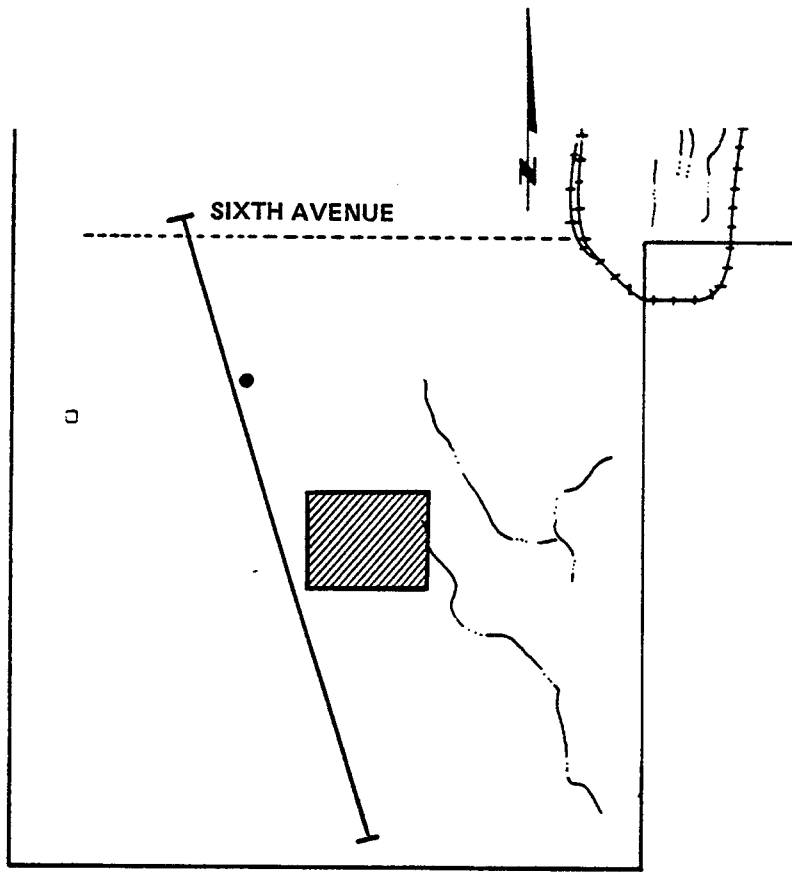



SERIES C
ABANDONED FARM WELLS AND
CONTAMINANT PLUME



SECTION 9

LEGEND

SERIES A MAPS

-  LINE OF CROSS SECTION
-  SURFACE STORAGE/DISPOSAL
-  BASIN/PIT DISPOSAL
-  NWI REGIONAL WELL
-  SHELL CHEMICAL WELL
-  OTHER WELL

SERIES A
LOCATION OF BORINGS AND
LINE OF SECTION

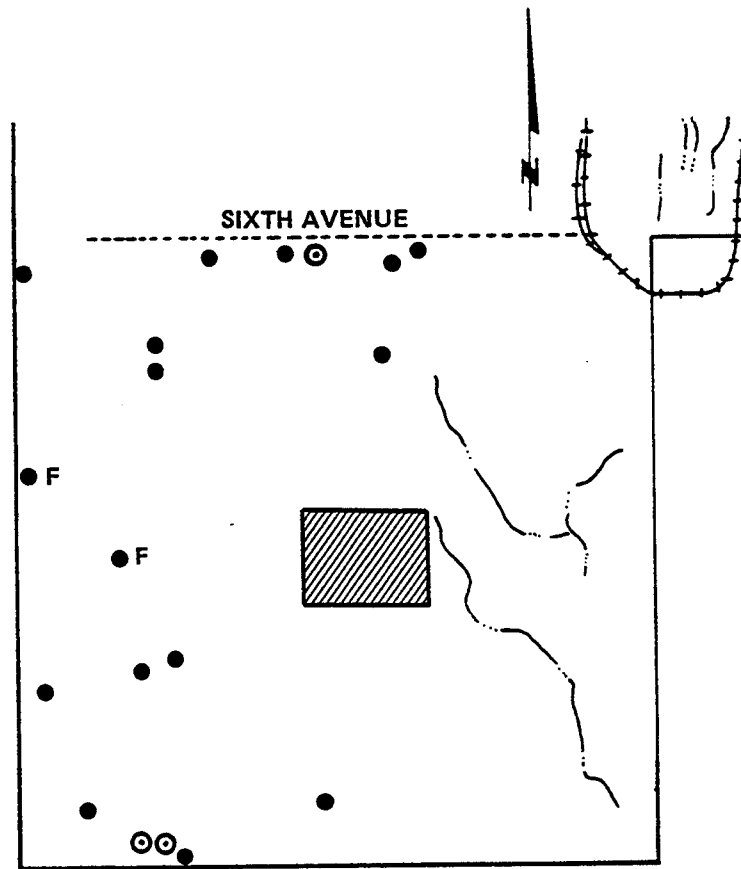

SECTION 9

LEGEND

SERIES C MAPS





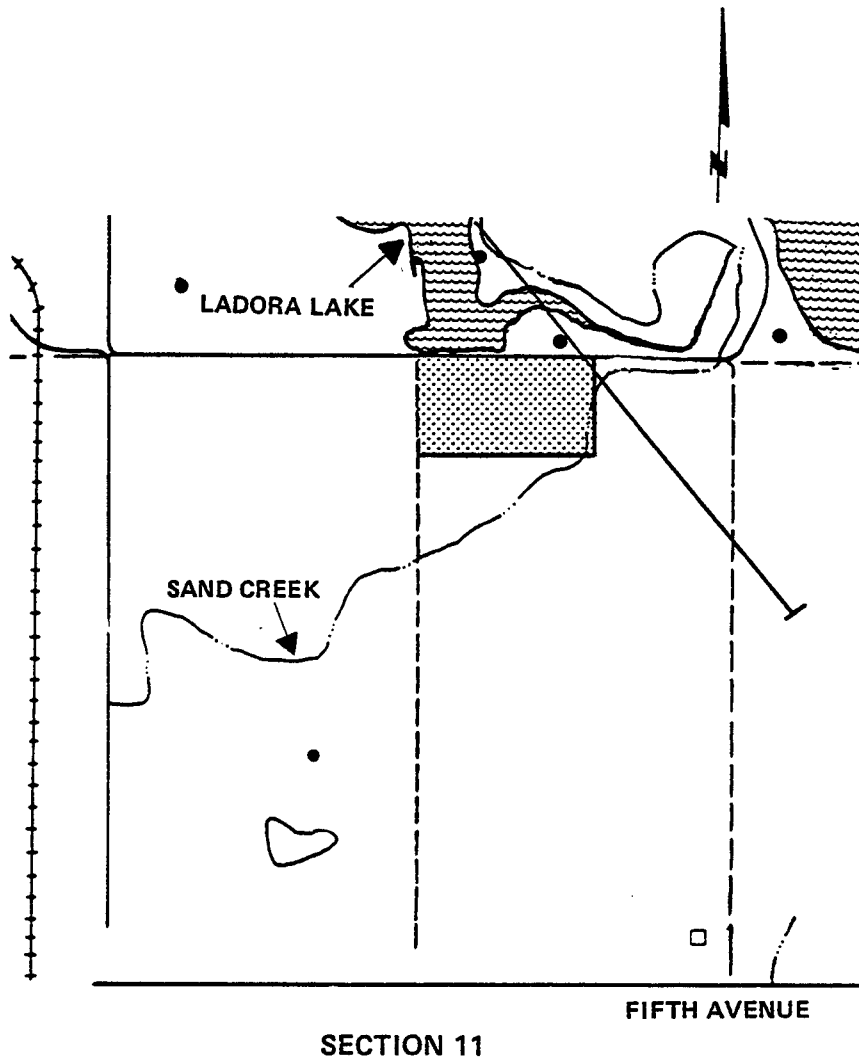

- SHALLOW ABANDONED FARM WELL
- F SHALLOW ABANDONED FARM WELL, FILLED
- ⊙ DEEP ABANDONED FARM WELL
- ▨ BASIN/PIT DISPOSAL

SERIES C
ABANDONED FARM WELLS AND
CONTAMINANT PLUME



LEGEND

SERIES A MAPS

- | | |
|---|---------------------------------|
|  | LINE OF CROSS SECTION |
|  | SURFACE STORAGE/DISPOSAL |
|  | BASIN/PIT DISPOSAL |
|  | NWI REGIONAL WELL |
|  | SHELL CHEMICAL WELL |
|  | OTHER WELL |

**SERIES A
LOCATION OF BORINGS AND
LINE OF SECTION**

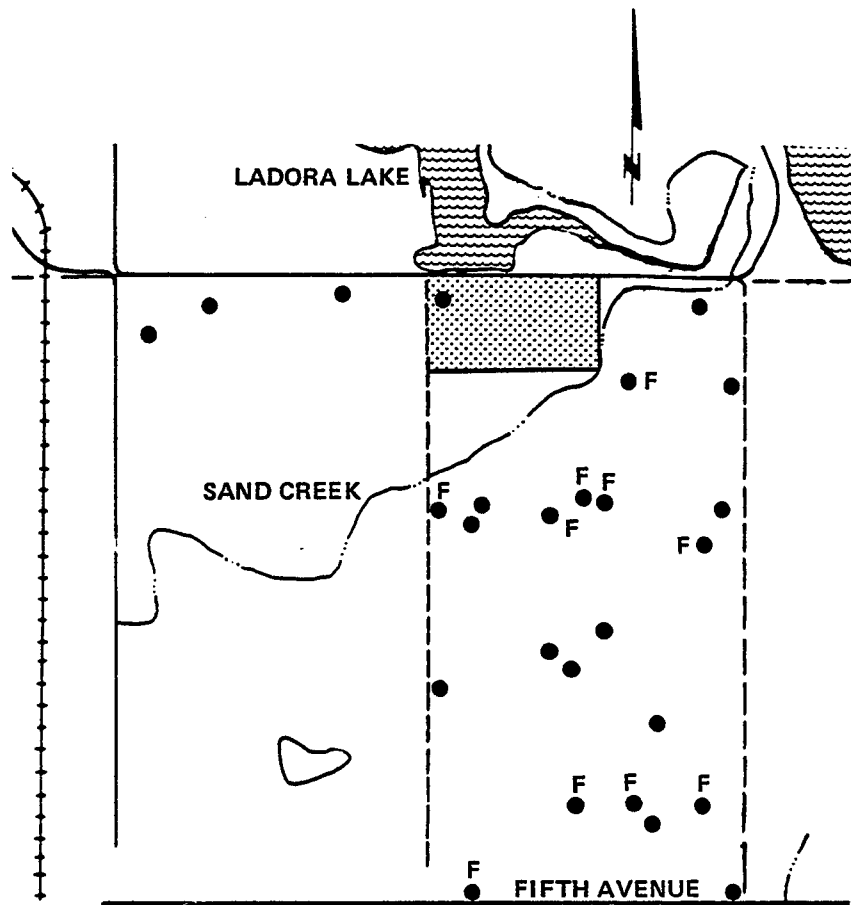

SECTION 11

LEGEND

SERIES C MAPS

- SHALLOW ABANDONED FARM WELL
- F SHALLOW ABANDONED FARM WELL, FILLED
-  SURFACE STORAGE/DISPOSAL

SERIES C
ABANDONED FARM WELLS AND
CONTAMINANT PLUME

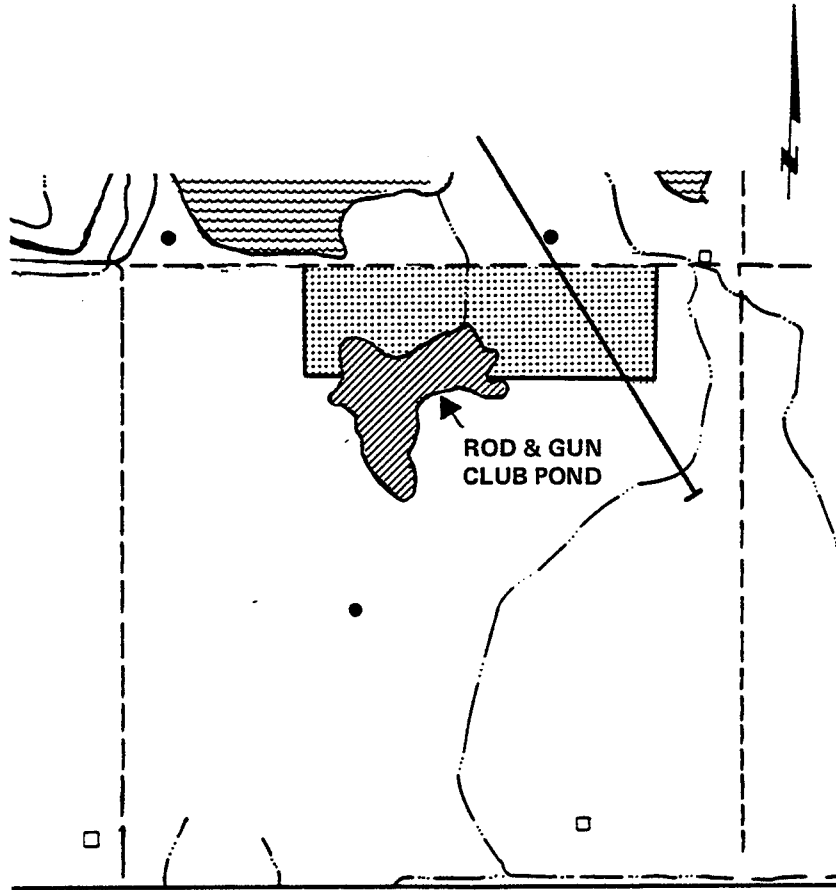

SECTION 12

LEGEND

SERIES A MAPS

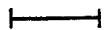

LINE OF CROSS SECTION



SURFACE STORAGE/DISPOSAL



BASIN/PIT DISPOSAL



NWI REGIONAL WELL



SHELL CHEMICAL WELL



OTHER WELL



**SERIES A
LOCATION OF BORINGS AND
LINE OF SECTION**



SECTION 12

LEGEND

SERIES C MAPS

- SHALLOW ABANDONED FARM WELL
- F SHALLOW ABANDONED FARM WELL, FILLED
-  BASIN/PIT DISPOSAL
-  SURFACE STORAGE/DISPOSAL



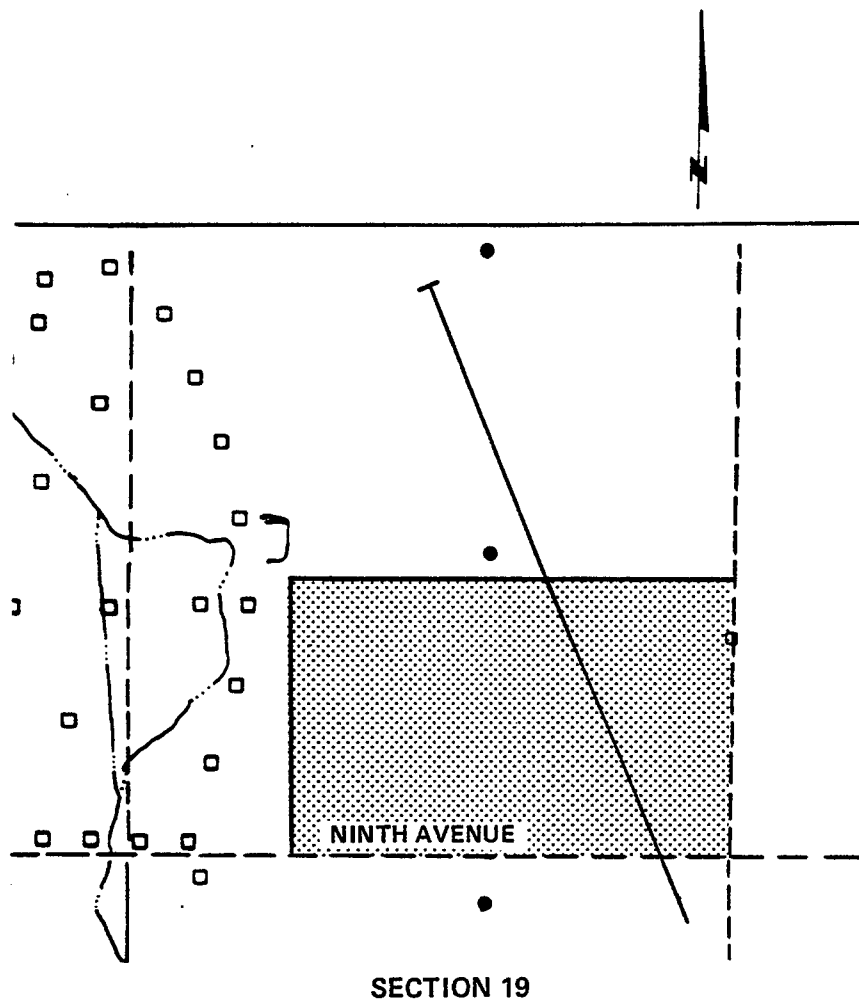



SERIES C
ABANDONED FARM WELLS AND
CONTAMINANT PLUME



SECTION 19

LEGEND

SERIES A MAPS

-  LINE OF CROSS SECTION
-  SURFACE STORAGE/DISPOSAL
-  BASIN/PIT DISPOSAL
-  NWI REGIONAL WELL
-  SHELL CHEMICAL WELL
-  OTHER WELL

**SERIES A
LOCATION OF BORINGS AND
LINE OF SECTION**

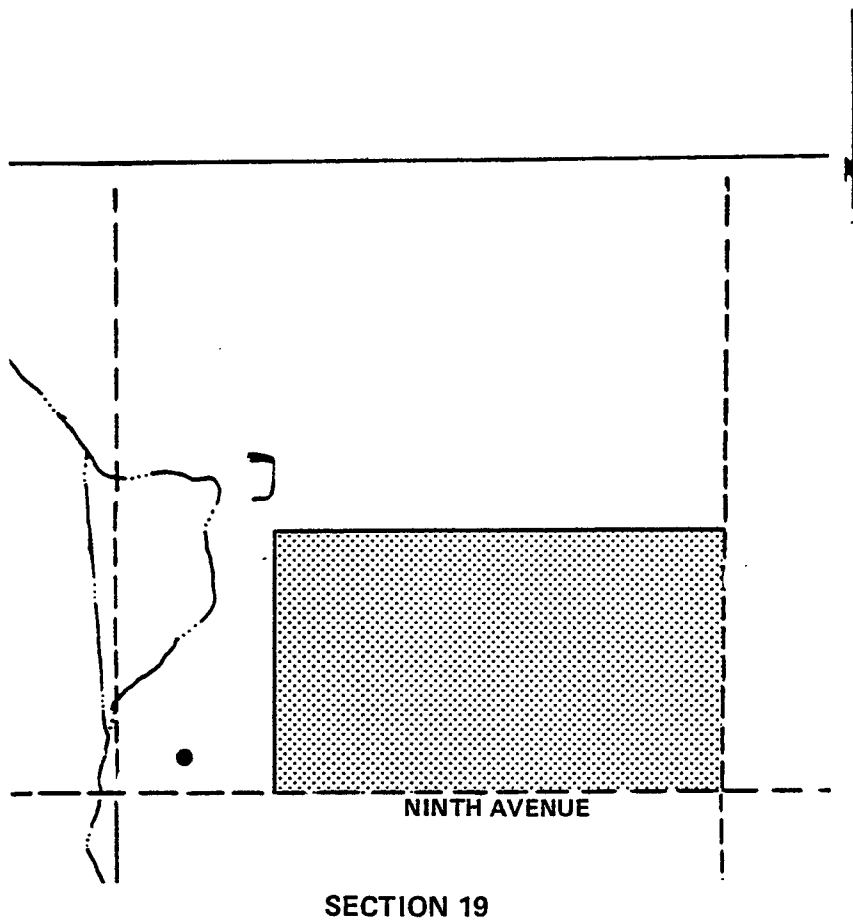

SECTION 19

LEGEND

SERIES C MAPS

- SHALLOW ABANDONED FARM WELL
-  SURFACE STORAGE/DISPOSAL



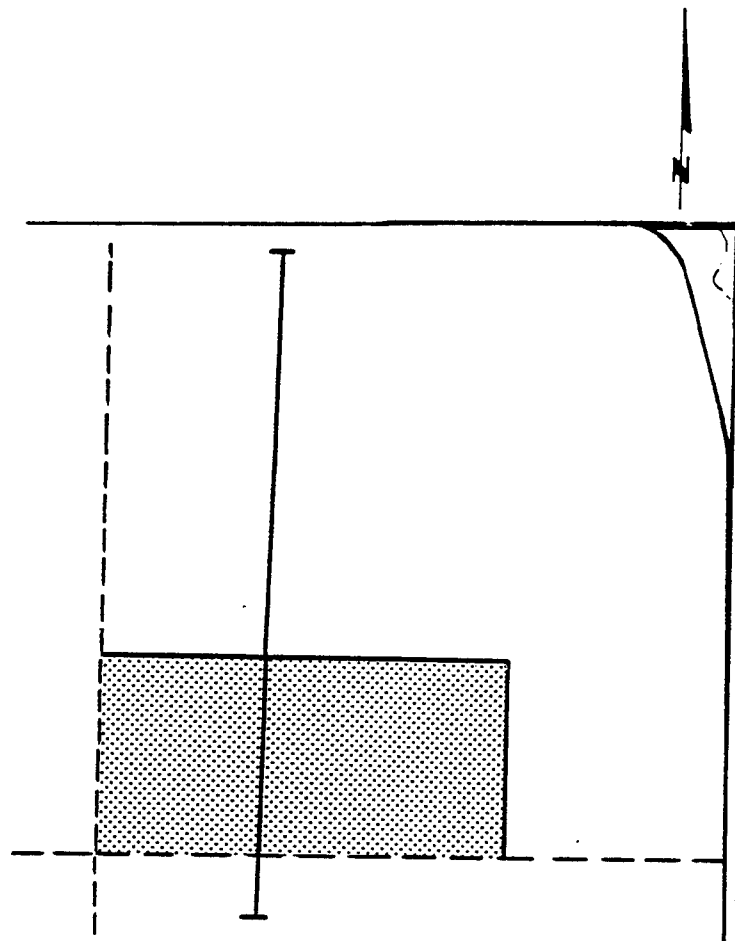



**SERIES C
ABANDONED FARM WELLS AND
CONTAMINANT PLUME**



SECTION 20

LEGEND

SERIES A MAPS

-  LINE OF CROSS SECTION
-  SURFACE STORAGE/DISPOSAL
-  BASIN/PIT DISPOSAL
-  NWI REGIONAL WELL
-  SHELL CHEMICAL WELL
-  OTHER WELL

SERIES A
LOCATION OF BORINGS AND
LINE OF SECTION

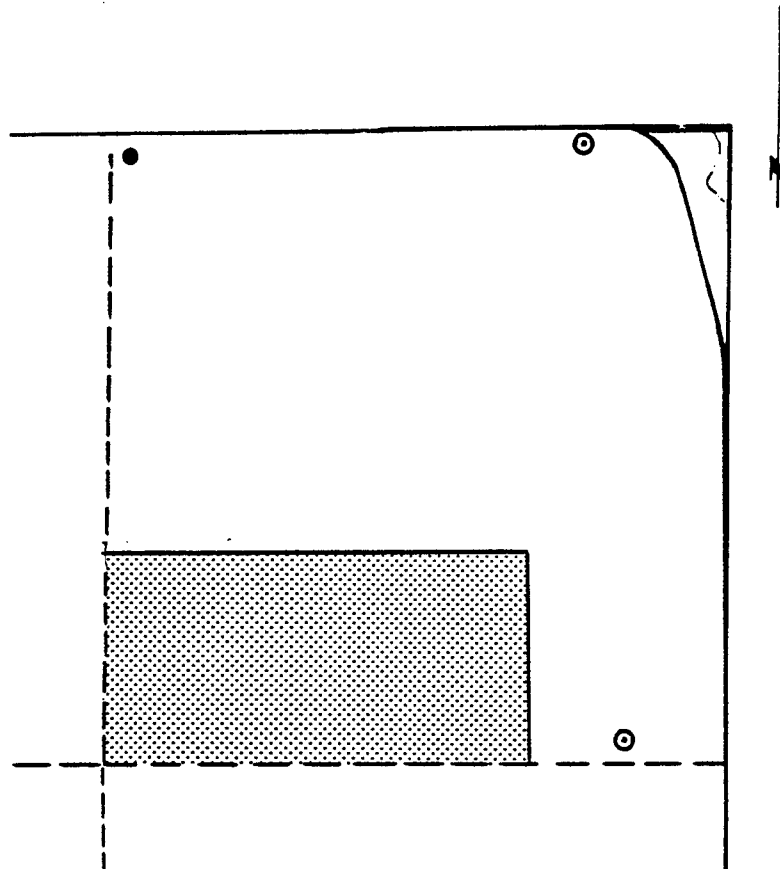

SECTION 20

LEGEND

SERIES C MAPS

- SHALLOW ABANDONED FARM WELL
- ⊙ DEEP ABANDONED FARM WELL
-  SURFACE STORAGE/DISPOSAL



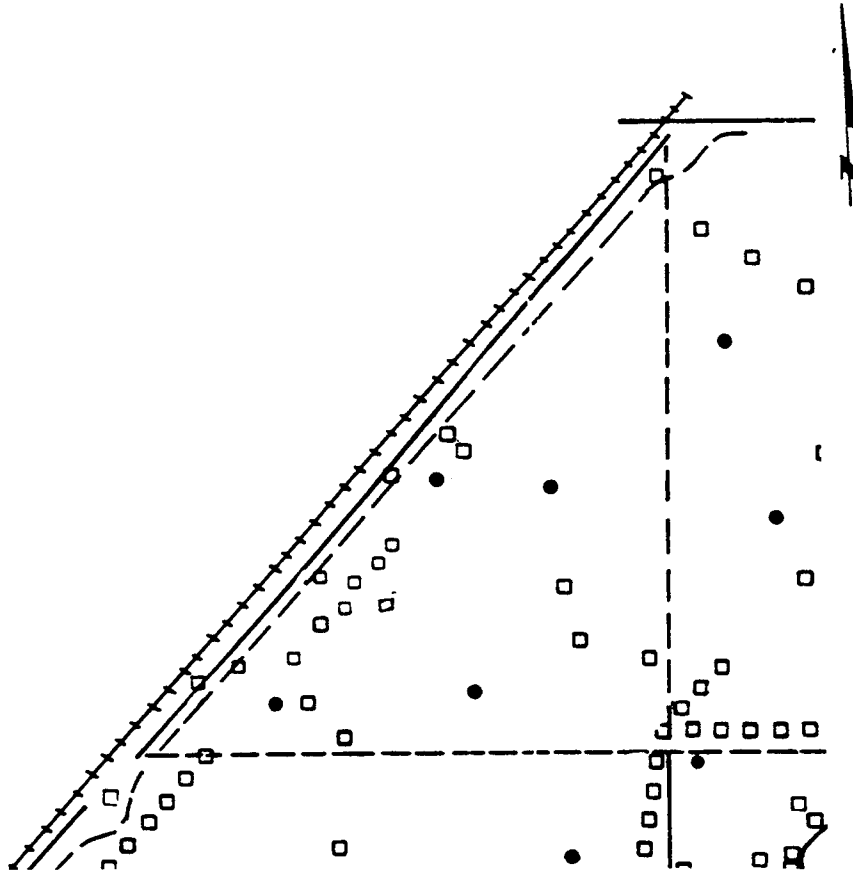



**SERIES C
ABANDONED FARM WELLS AND
CONTAMINANT PLUME**



SECTION 22

LEGEND

SERIES A MAPS

- 
 LINE OF CROSS SECTION
- 
 SURFACE STORAGE/DISPOSAL
- 
 BASIN/PIT DISPOSAL
- 
 NWI REGIONAL WELL
- 
 SHELL CHEMICAL WELL
- 
 OTHER WELL

SERIES A
 LOCATION OF BORINGS AND
 LINE OF SECTION

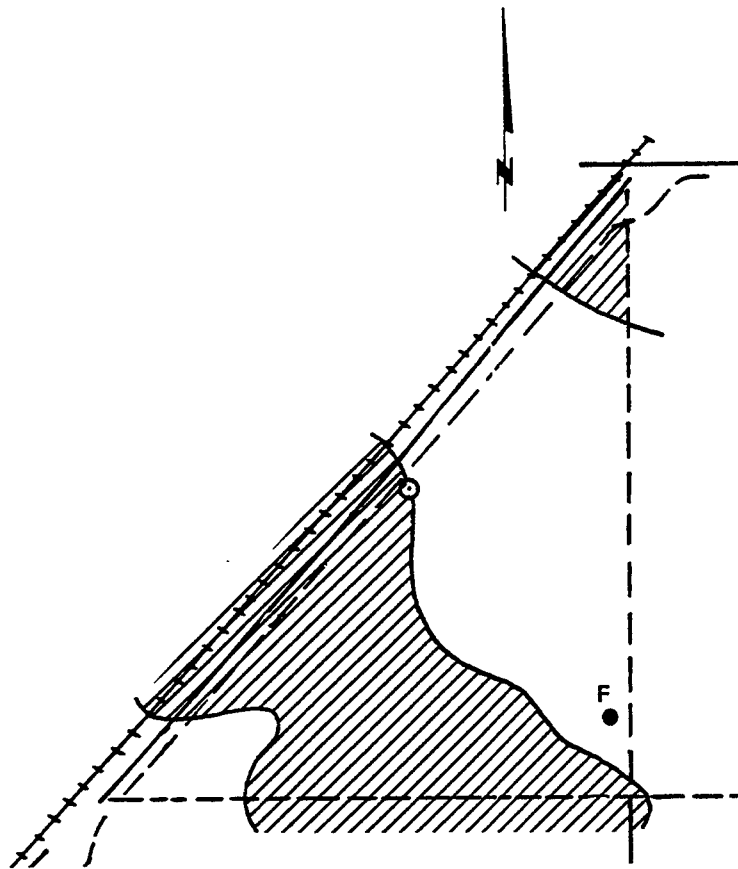

SECTION 22

LEGEND

SERIES C MAPS

- F SHALLOW ABANDONED FARM WELL, FILLED
- ⊙ DEEP ABANDONED FARM WELL
-  LATERAL EXTENT OF PLUME, IF PRESENT



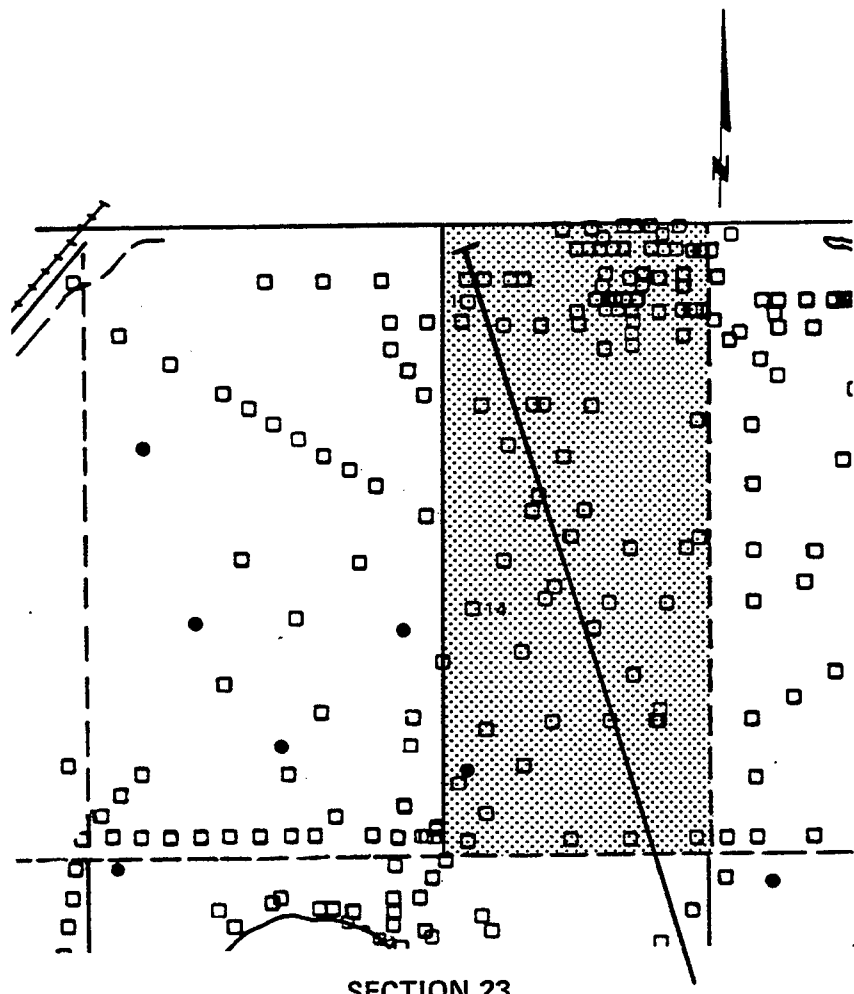



**SERIES C
ABANDONED FARM WELLS AND
CONTAMINANT PLUME**



SECTION 23

LEGEND

SERIES A MAPS

-  LINE OF CROSS SECTION
-  SURFACE STORAGE/DISPOSAL
-  BASIN/PIT DISPOSAL
-  NWI REGIONAL WELL
-  SHELL CHEMICAL WELL
-  OTHER WELL

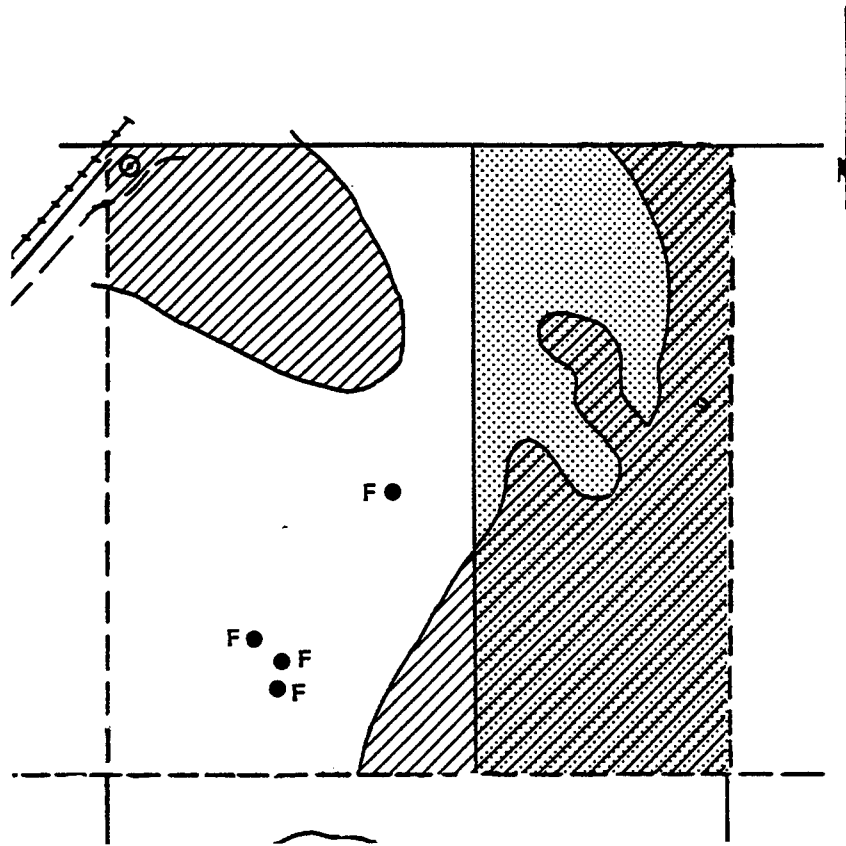

SERIES A
LOCATION OF BORINGS AND
LINE OF SECTION



SECTION 23

LEGEND

SERIES C MAPS

- SHALLOW ABANDONED FARM WELL
- F SHALLOW ABANDONED FARM WELL, FILLED
- ⊙ DEEP ABANDONED FARM WELL
-  LATERAL EXTENT OF PLUME, IF PRESENT
-  SURFACE STORAGE/DISPOSAL

**SERIES C
ABANDONED FARM WELLS AND
CONTAMINANT PLUME**

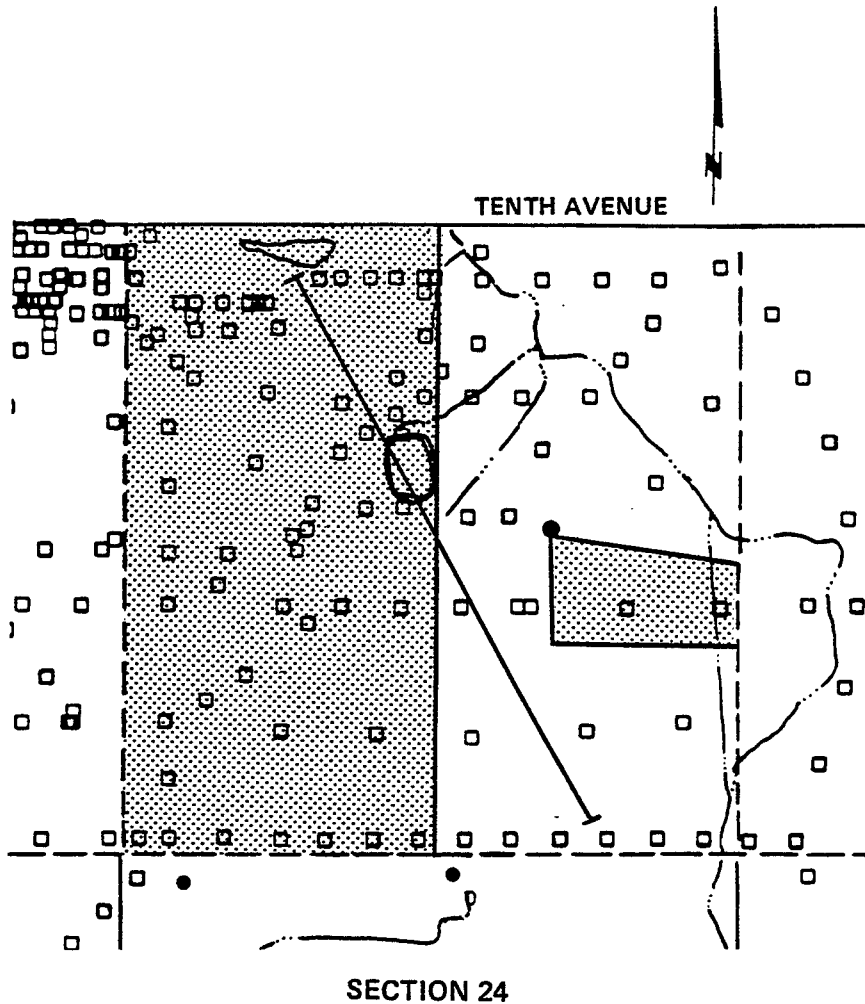

LEGEND

SERIES A MAPS

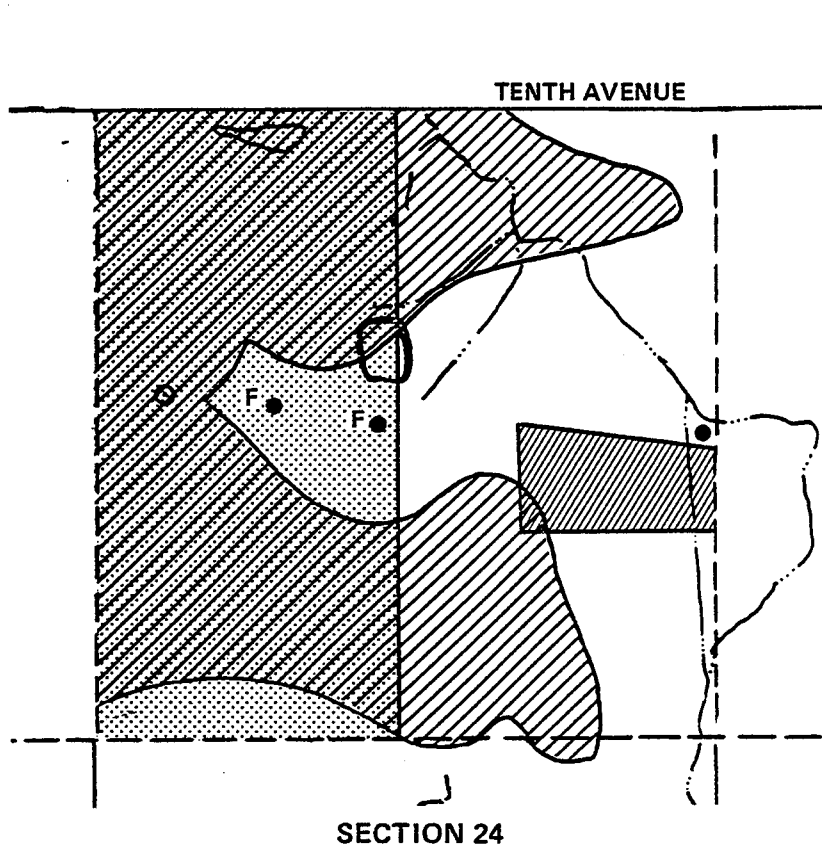

- | | |
|-------|--------------------------|
| ----- | LINE OF CROSS SECTION |
| ▨ | SURFACE STORAGE/DISPOSAL |
| ▩ | BASIN/PIT DISPOSAL |
| ● | NWI REGIONAL WELL |
| ▲ | SHELL CHEMICAL WELL |
| □ | OTHER WELL |

**SERIES A
LOCATION OF BORINGS AND
LINE OF SECTION**



LEGEND

SERIES C MAPS

- SHALLOW ABANDONED FARM WELL
- F SHALLOW ABANDONED FARM WELL, FILLED
- ⊙ DEEP ABANDONED FARM WELL
-  LATERAL EXTENT OF PLUME, IF PRESENT
-  SURFACE STORAGE/DISPOSAL
-  BASIN/PIT DISPOSAL



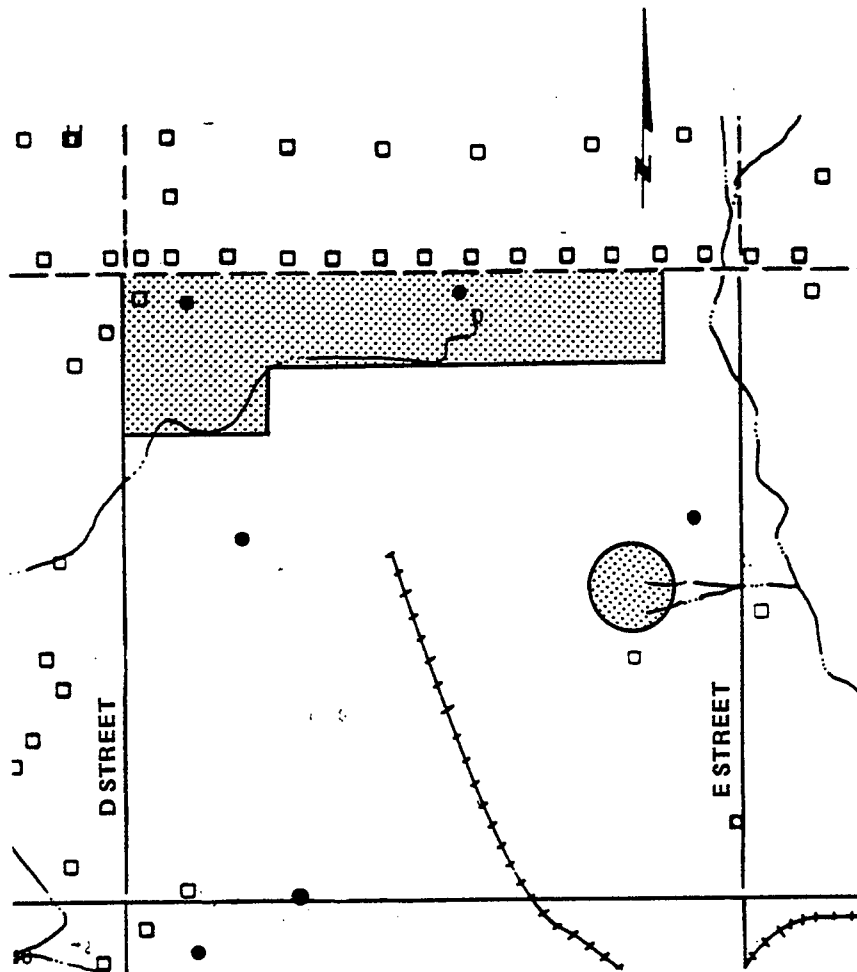



**SERIES C
ABANDONED FARM WELLS AND
CONTAMINANT PLUME**



SECTION 25

LEGEND

SERIES A MAPS

- 
 LINE OF CROSS SECTION
- 
 SURFACE STORAGE/DISPOSAL
- 
 BASIN/PIT DISPOSAL
- 
 NWI REGIONAL WELL
- 
 SHELL CHEMICAL WELL
- 
 OTHER WELL

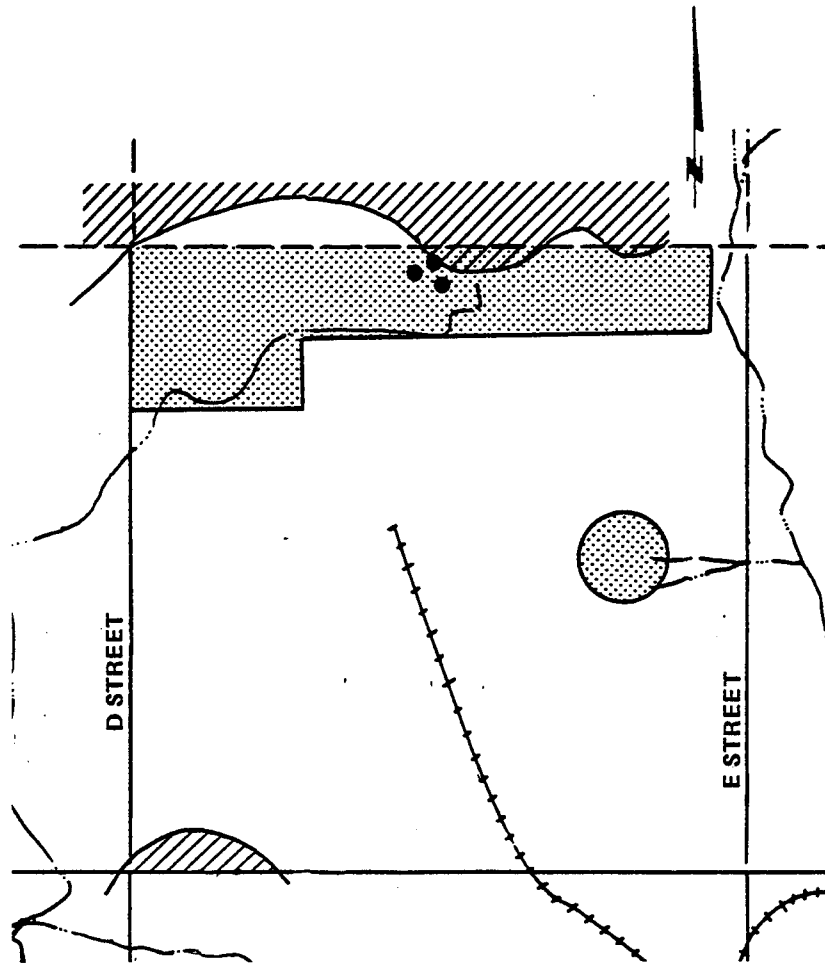

SERIES A
LOCATION OF BORINGS AND
LINE OF SECTION



SECTION 25

LEGEND

SERIES C MAPS

- SHALLOW ABANDONED FARM WELL
-  LATERAL EXTENT OF PLUME, IF PRESENT
-  SURFACE STORAGE/DISPOSAL

SERIES C
ABANDONED FARM WELLS AND
CONTAMINANT PLUME

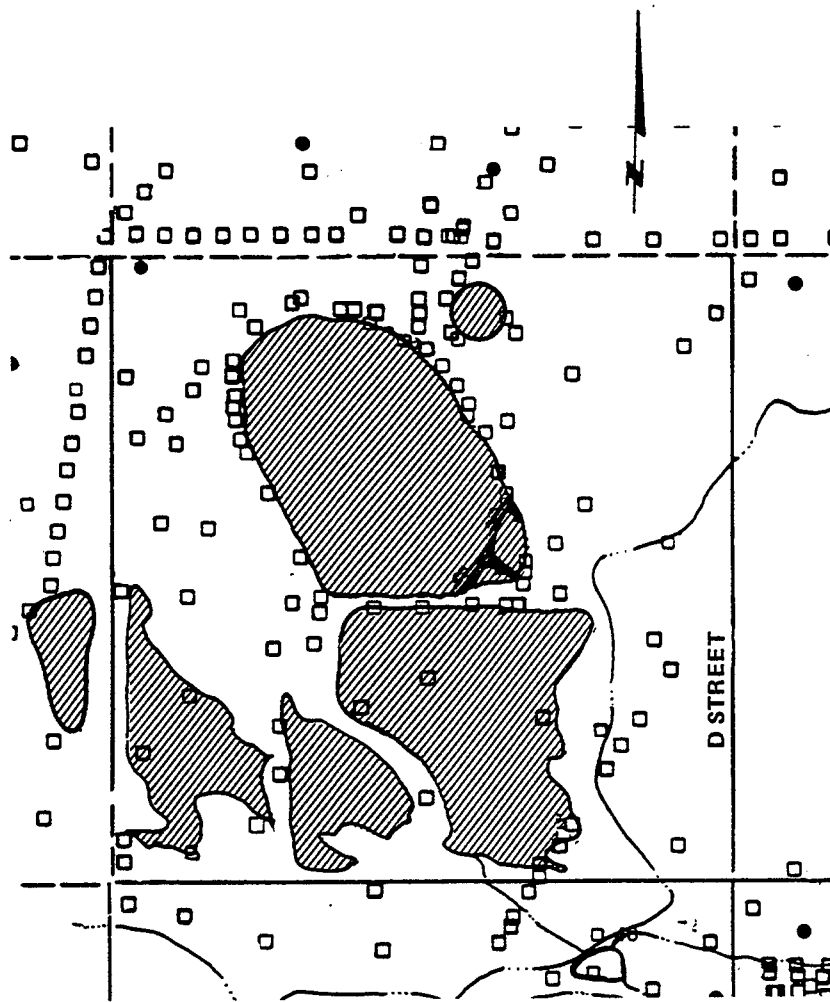

SECTION 26

LEGEND

SERIES A MAPS



LINE OF CROSS SECTION



SURFACE STORAGE/DISPOSAL



BASIN/PIT DISPOSAL



NWI REGIONAL WELL



SHELL CHEMICAL WELL



OTHER WELL

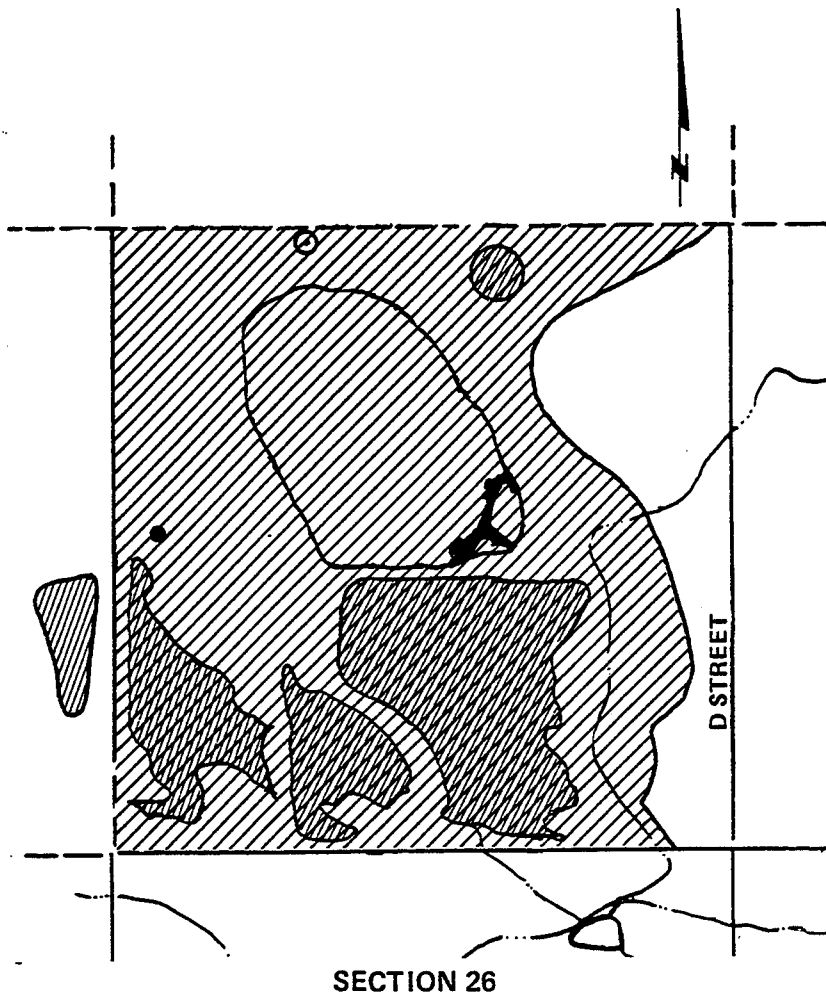

SERIES A
LOCATION OF BORINGS AND
LINE OF SECTION



SECTION 26

LEGEND

SERIES C MAPS

- SHALLOW ABANDONED FARM WELL
- ⊙ DEEP ABANDONED FARM WELL
-  LATERAL EXTENT OF PLUME, IF PRESENT
-  BASIN/PIT DISPOSAL



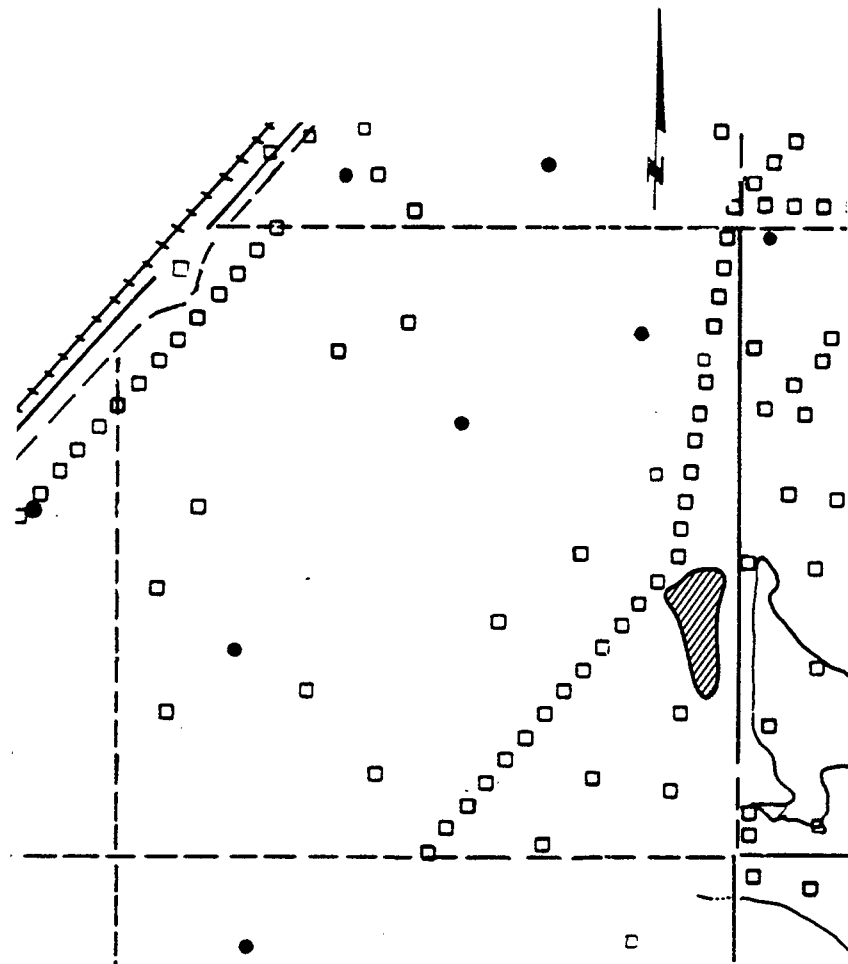



**SERIES C
ABANDONED FARM WELLS AND
CONTAMINANT PLUME**



SECTION 27

LEGEND

SERIES A MAPS

- 
 LINE OF CROSS SECTION
- 
 SURFACE STORAGE/DISPOSAL
- 
 BASIN/PIT DISPOSAL
- 
 NWI REGIONAL WELL
- 
 SHELL CHEMICAL WELL
- 
 OTHER WELL

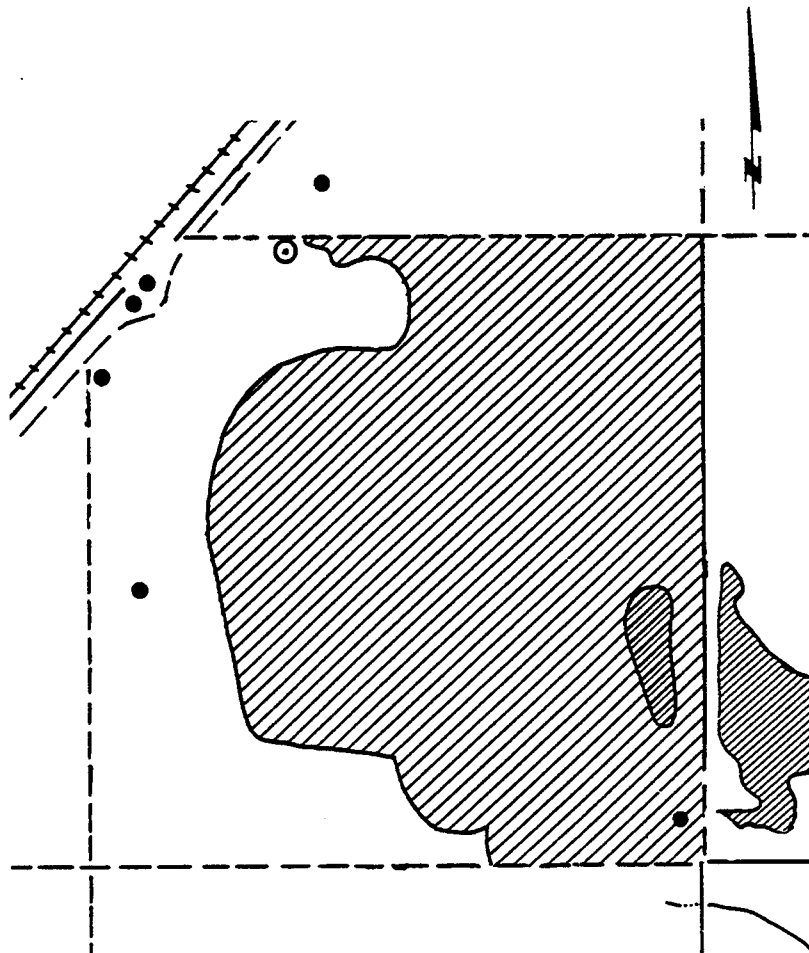

SERIES A
 LOCATION OF BORINGS AND
 LINE OF SECTION



SECTION 27

LEGEND

SERIES C MAPS

- SHALLOW ABANDONED FARM WELL
- ⊙ DEEP ABANDONED FARM WELL
-  LATERAL EXTENT OF PLUME, IF PRESENT
-  BASIN/PIT DISPOSAL

SERIES C
ABANDONED FARM WELLS AND
CONTAMINANT PLUME

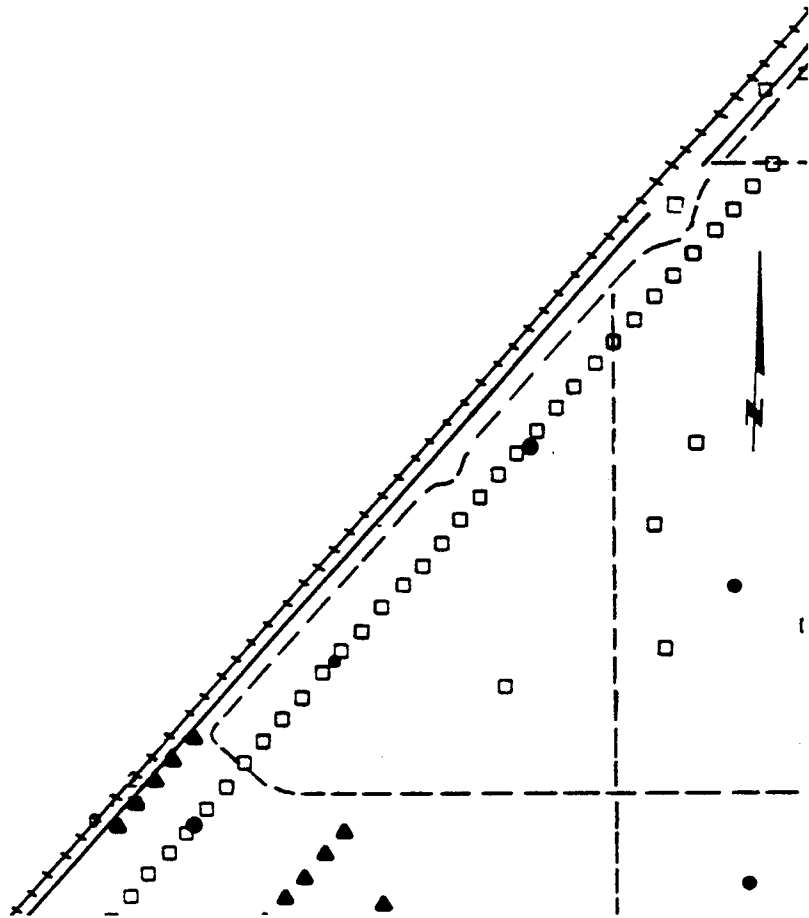

SECTION 28

LEGEND

SERIES A MAPS



LINE OF CROSS SECTION



SURFACE STORAGE/DISPOSAL



BASIN/PIT DISPOSAL



NWI REGIONAL WELL



SHELL CHEMICAL WELL



OTHER WELL

SERIES A
LOCATION OF BORINGS AND
LINE OF SECTION

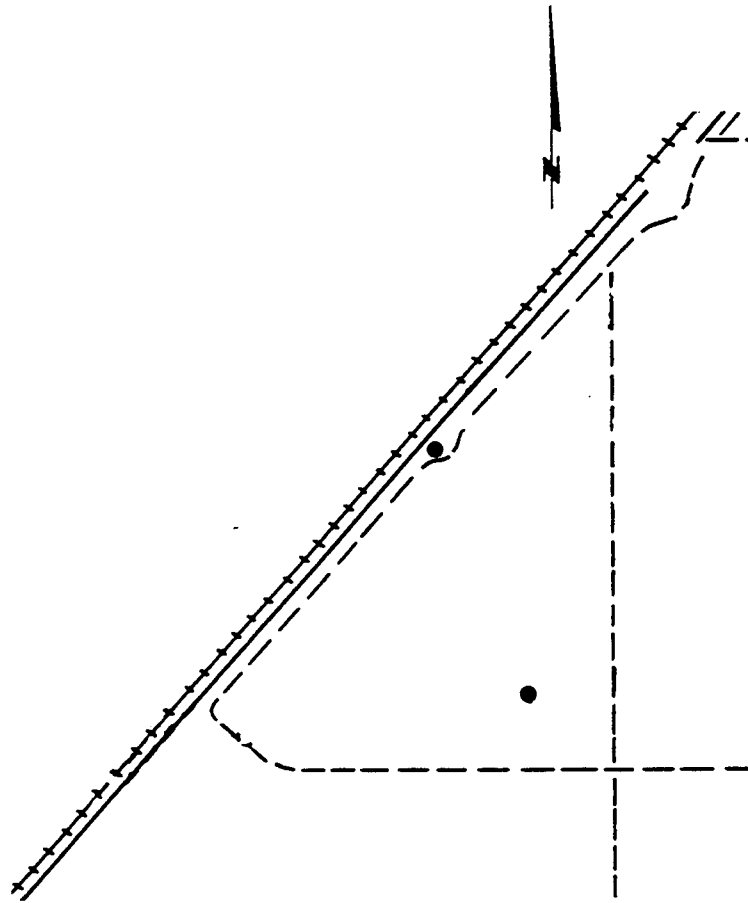

SECTION 28

LEGEND

SERIES C MAPS

● **SHALLOW ABANDONED FARM WELL**



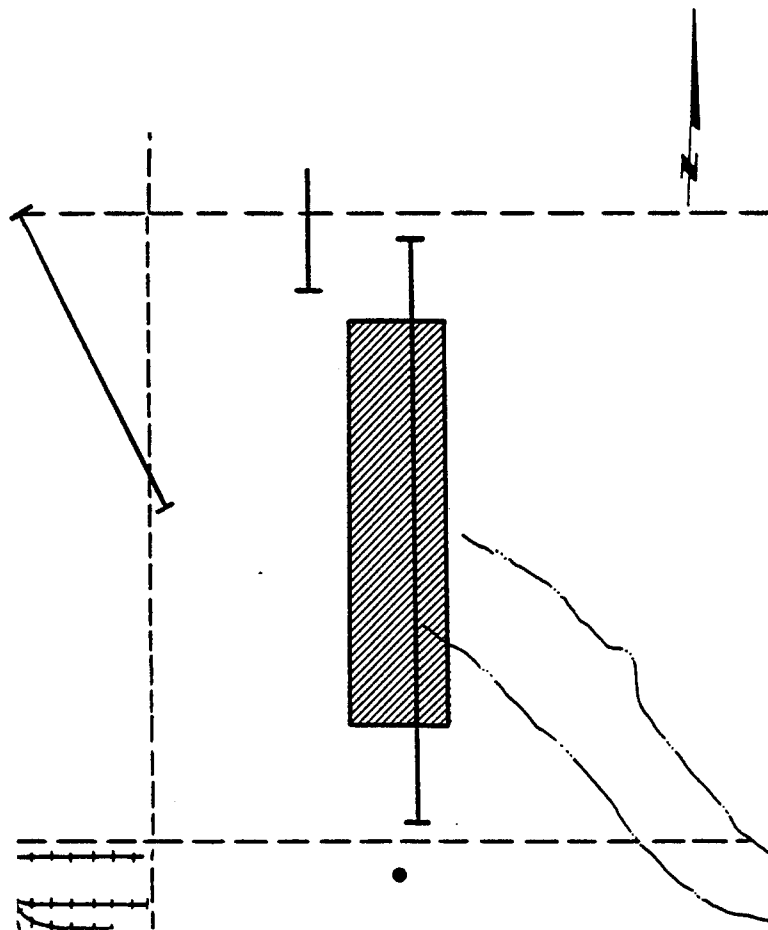



**SERIES C
ABANDONED FARM WELLS AND
CONTAMINANT PLUME**



SECTION 29

LEGEND

SERIES A MAPS

- | | |
|---|--------------------------|
|  | LINE OF CROSS SECTION |
|  | SURFACE STORAGE/DISPOSAL |
|  | BASIN/PIT DISPOSAL |
|  | NWI REGIONAL WELL |
|  | SHELL CHEMICAL WELL |
|  | OTHER WELL |

SERIES A
LOCATION OF BORINGS AND
LINE OF SECTION

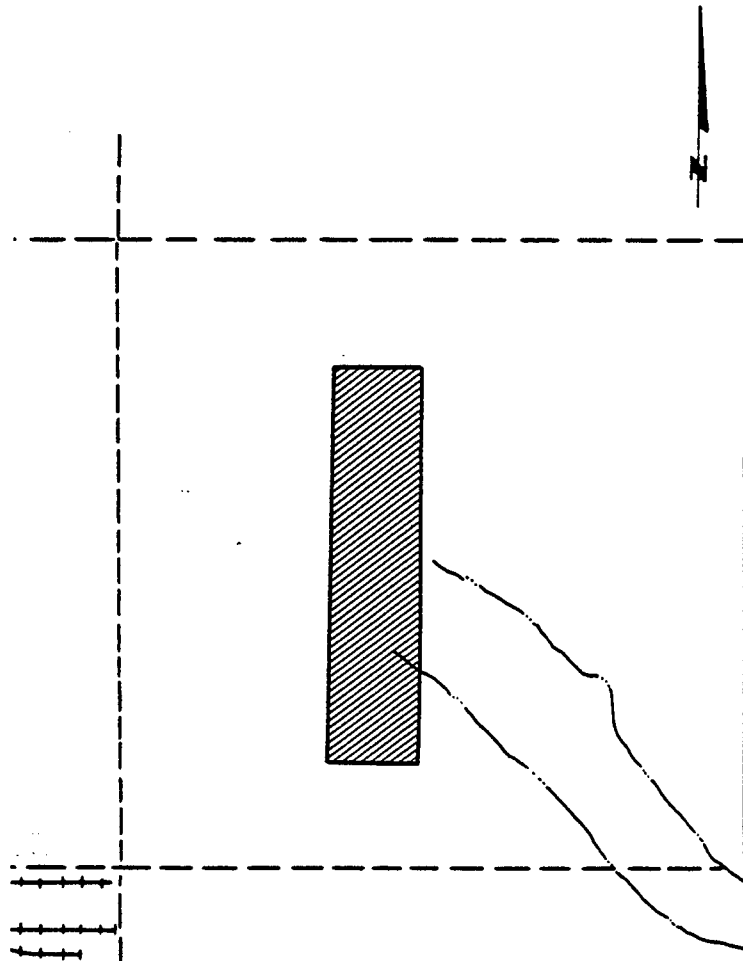

SECTION 29

LEGEND

SERIES C MAPS



BASIN/PIT DISPOSAL



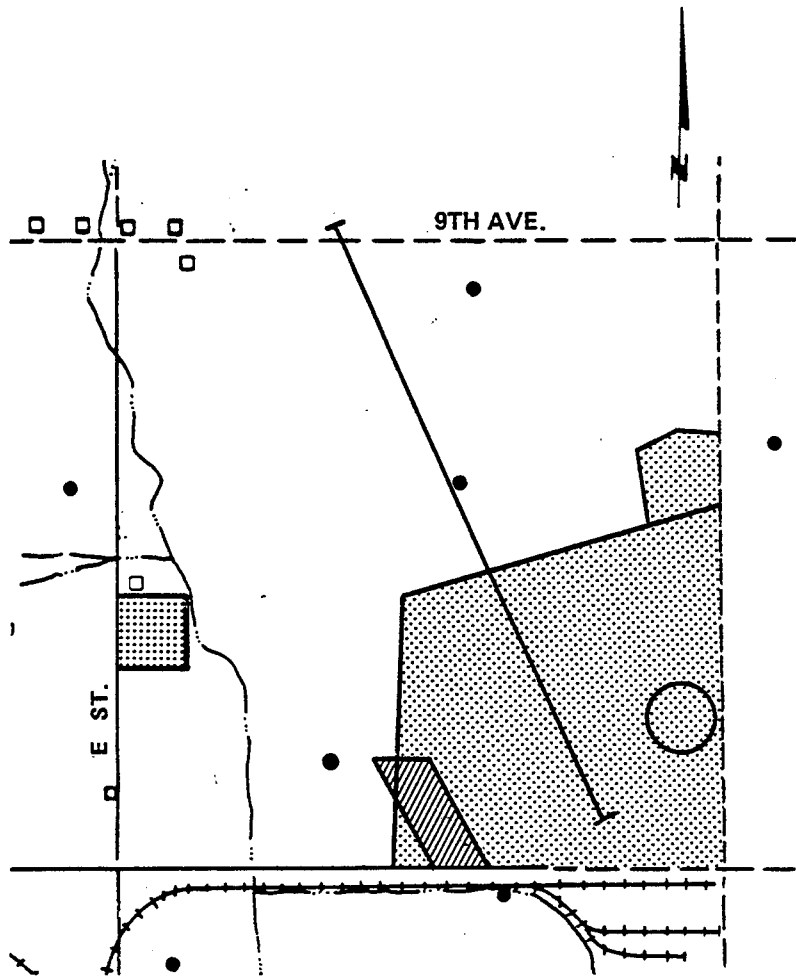



**SERIES C
ABANDONED FARM WELLS AND
CONTAMINANT PLUME**



SECTION 30

LEGEND

SERIES A MAPS

-  LINE OF CROSS SECTION
-  SURFACE STORAGE/DISPOSAL
-  BASIN/PIT DISPOSAL
-  NWI REGIONAL WELL
-  SHELL CHEMICAL WELL
-  OTHER WELL

SERIES A
LOCATION OF BORINGS AND
LINE OF SECTION

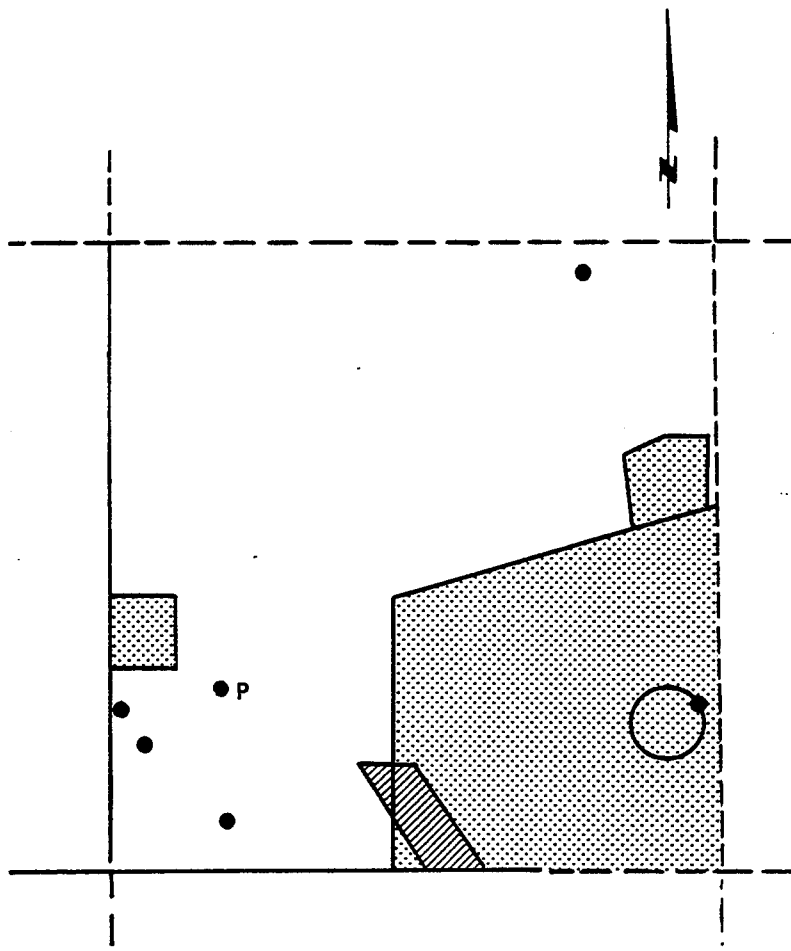

SECTION 30

LEGEND

SERIES C MAPS

- SHALLOW ABANDONED FARM WELL
- P SHALLOW ABANDONED FARM WELL, PLUGGED
- ▨ SURFACE STORAGE/DISPOSAL
- ▩ BASIN/PIT DISPOSAL



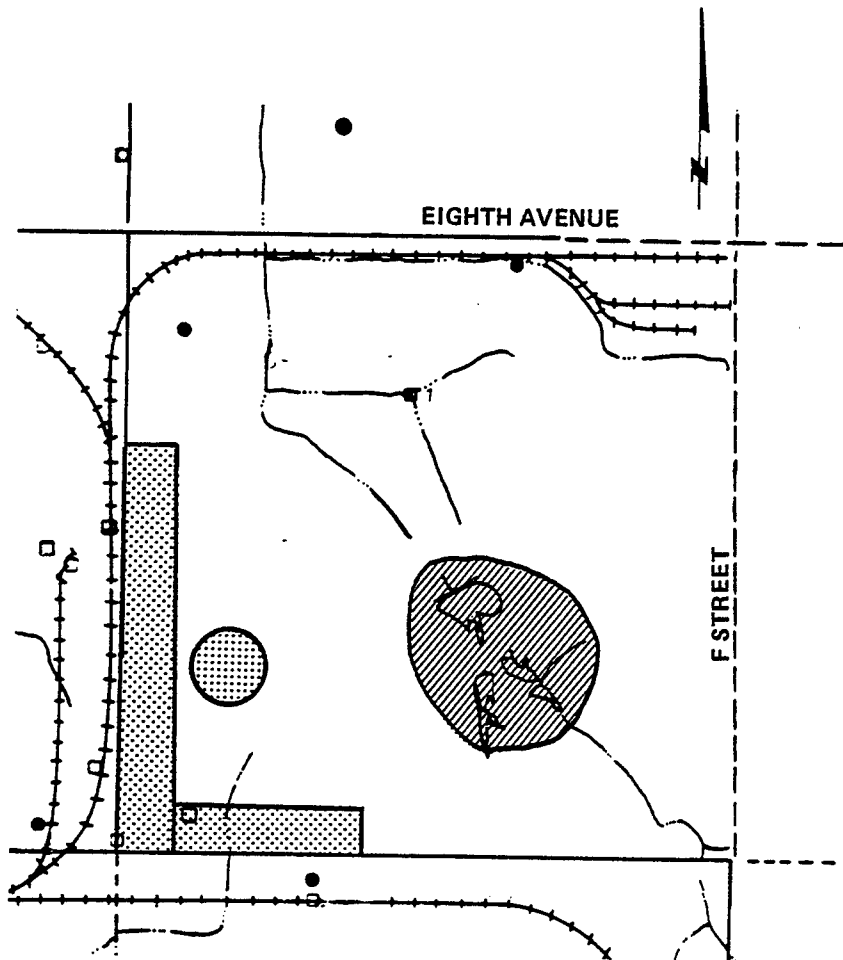



SERIES C
ABANDONED FARM WELLS AND
CONTAMINANT PLUME



SECTION 31

LEGEND

SERIES A MAPS

- 
LINE OF CROSS SECTION
- 
SURFACE STORAGE/DISPOSAL
- 
BASIN/PIT DISPOSAL
- 
NWI REGIONAL WELL
- 
SHELL CHEMICAL WELL
- 
OTHER WELL

**SERIES A
LOCATION OF BORINGS AND
LINE OF SECTION**

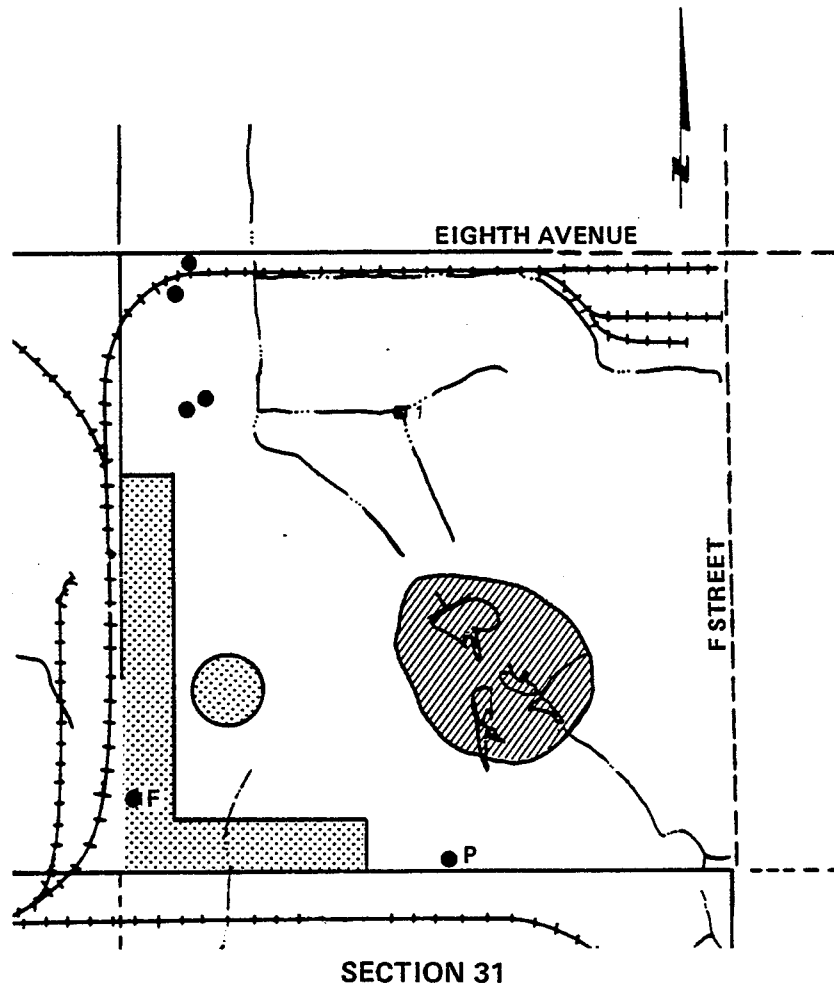

LEGEND

SERIES C MAPS

- SHALLOW ABANDONED FARM WELL
- F SHALLOW ABANDONED FARM WELL, FILLED
- P SHALLOW ABANDONED FARM WELL, PLUGGED
- ▨ SURFACE STORAGE/DISPOSAL
- ▩ BASIN/PIT DISPOSAL

**SERIES C
ABANDONED FARM WELLS AND
CONTAMINANT PLUME**

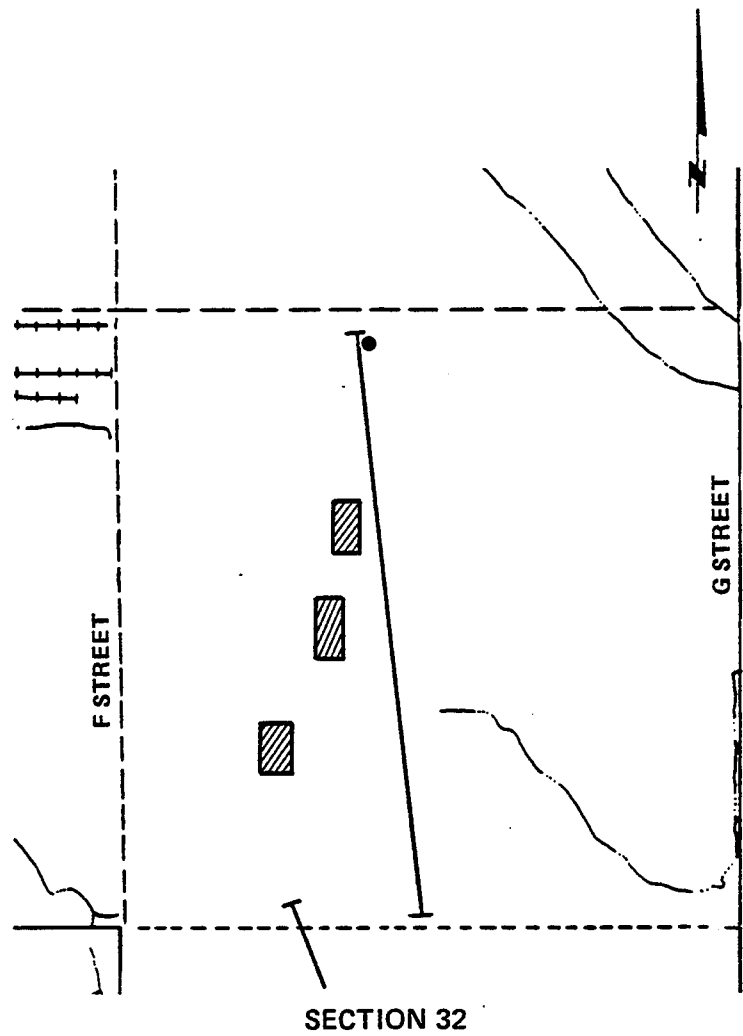

LEGEND

SERIES A MAPS



LINE OF CROSS SECTION



SURFACE STORAGE/DISPOSAL



BASIN/PIT DISPOSAL



NWI REGIONAL WELL



SHELL CHEMICAL WELL



OTHER WELL

**SERIES A
LOCATION OF BORINGS AND
LINE OF SECTION**

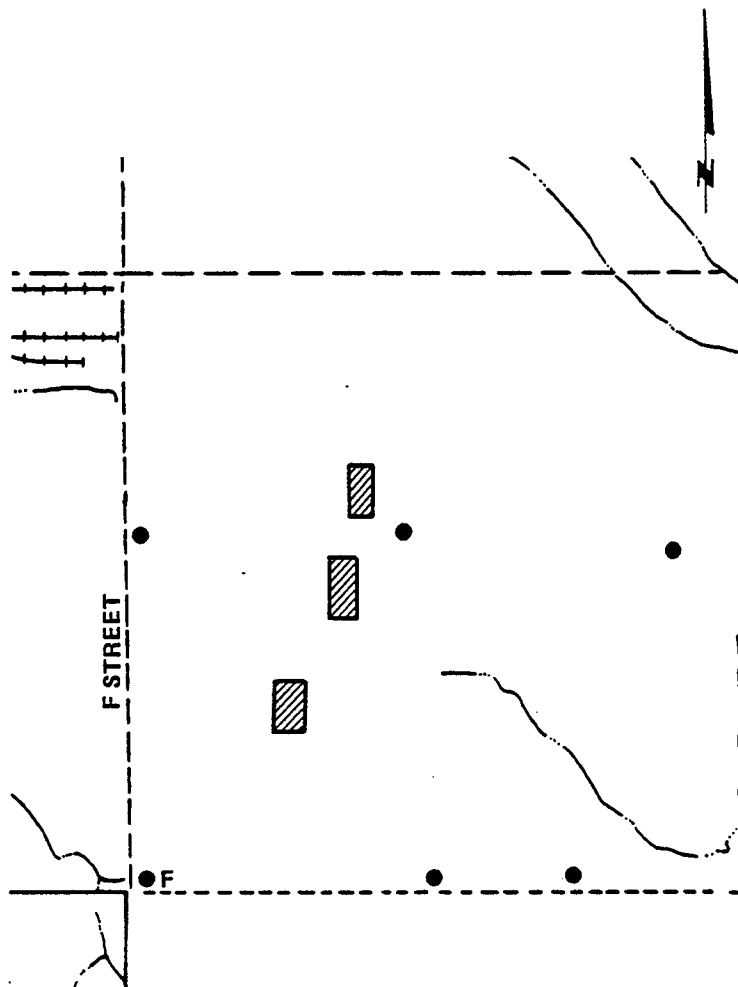

SECTION 32

LEGEND

SERIES C MAPS

- SHALLOW ABANDONED FARM WELL
- F SHALLOW ABANDONED FARM WELL, FILLED
-  BASIN/PIT DISPOSAL



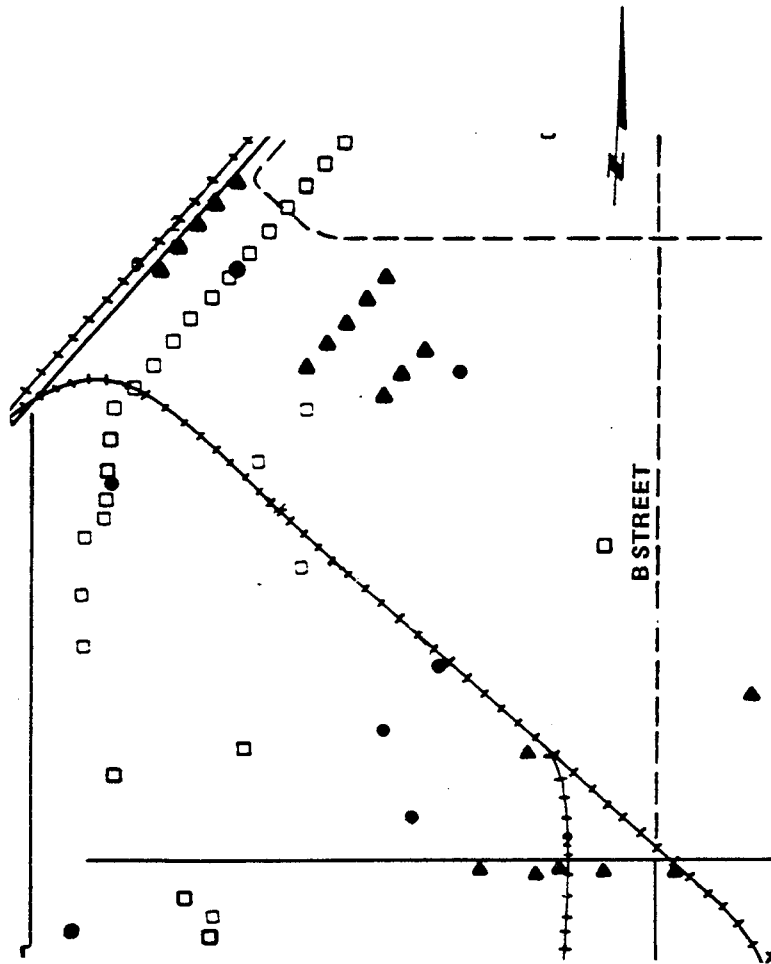



SERIES C
 ABANDONED FARM WELLS AND
 CONTAMINANT PLUME



SECTION 33

LEGEND

SERIES A MAPS

- 
LINE OF CROSS SECTION
- 
SURFACE STORAGE/DISPOSAL
- 
BASIN/PIT DISPOSAL
- 
NWI REGIONAL WELL
- 
SHELL CHEMICAL WELL
- 
OTHER WELL

SERIES A
 LOCATION OF BORINGS AND
 LINE OF SECTION

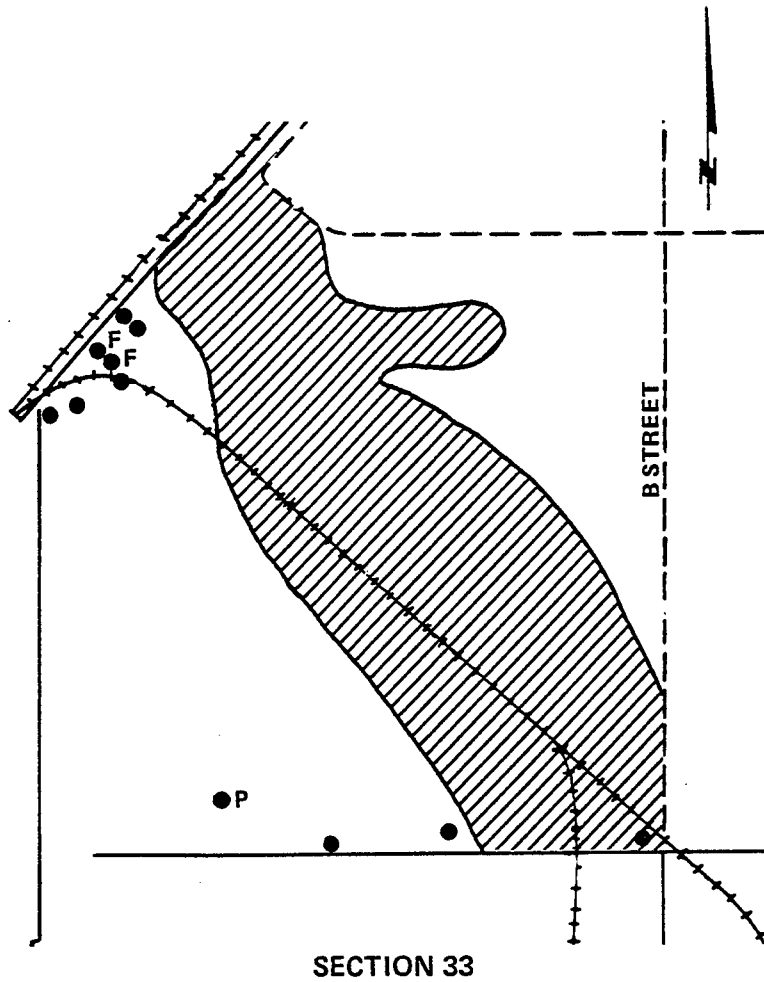

LEGEND

SERIES C MAPS

- SHALLOW ABANDONED FARM WELL
- F SHALLOW ABANDONED FARM WELL, FILLED
- P SHALLOW ABANDONED FARM WELL, PLUGGED
-  LATERAL EXTENT OF PLUME, IF PRESENT



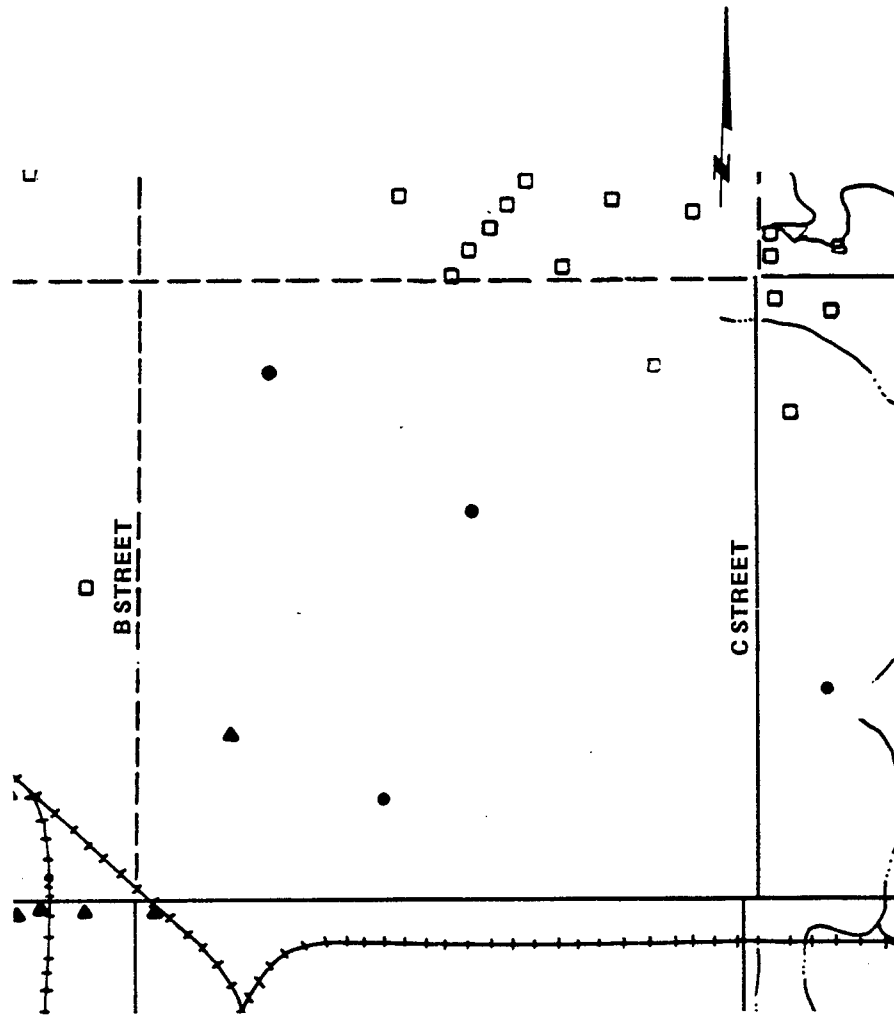



**SERIES C
ABANDONED FARM WELLS AND
CONTAMINANT PLUME**



SECTION 34

LEGEND

SERIES A MAPS

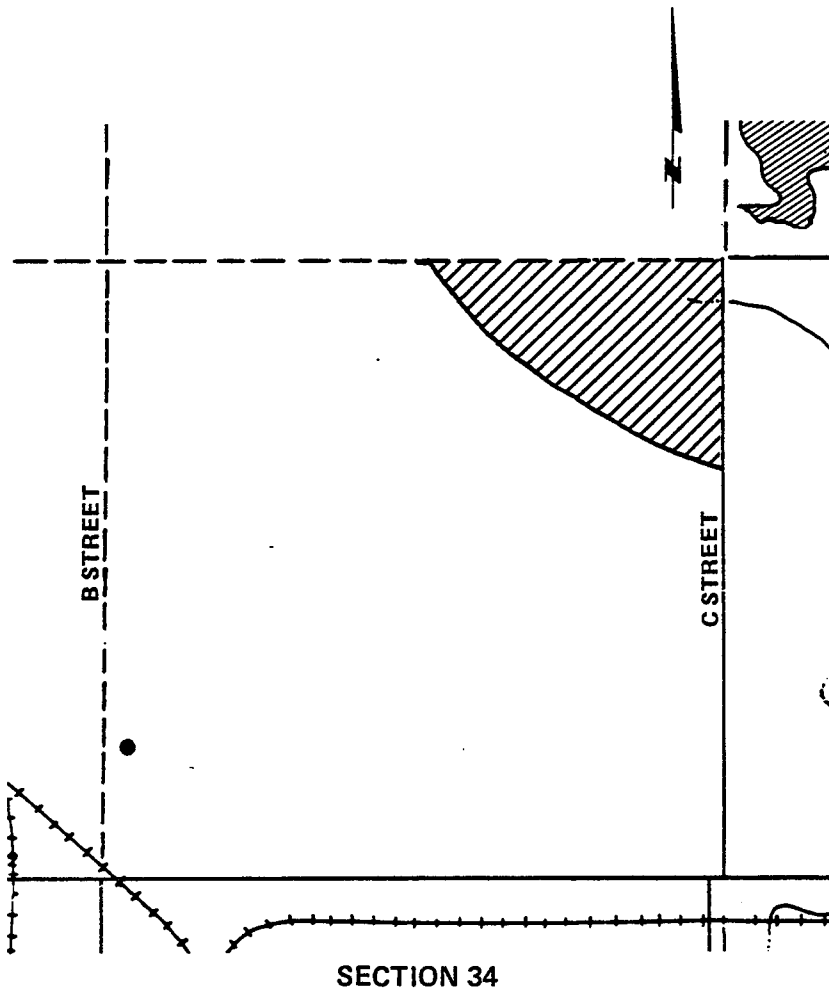

- 
 LINE OF CROSS SECTION
- 
 SURFACE STORAGE/DISPOSAL
- 
 BASIN/PIT DISPOSAL
- 
 NWI REGIONAL WELL
- 
 SHELL CHEMICAL WELL
- 
 OTHER WELL

SERIES A
 LOCATION OF BORINGS AND
 LINE OF SECTION



LEGEND

SERIES C MAPS

- SHALLOW ABANDONED FARM WELL
-  LATERAL EXTENT OF PLUME, IF PRESENT
-  BASIN/PIT DISPOSAL

**SERIES C
ABANDONED FARM WELLS AND
CONTAMINANT PLUME**

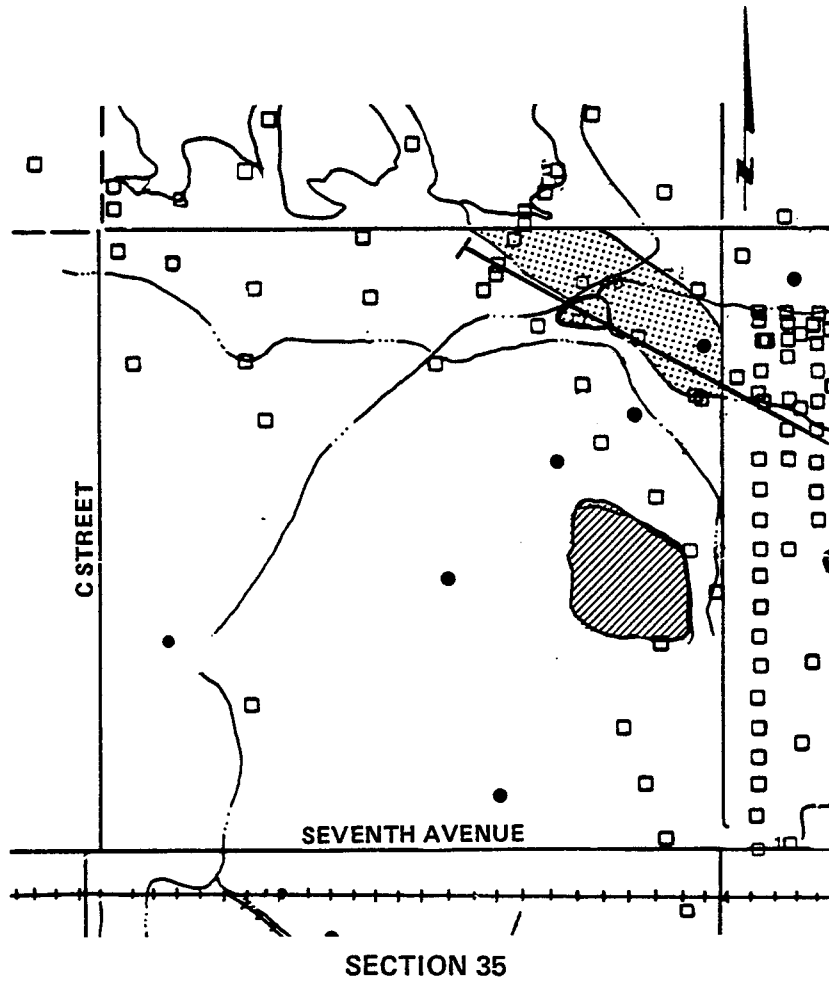

LEGEND

SERIES A MAPS



LINE OF CROSS SECTION



SURFACE STORAGE/DISPOSAL

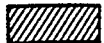

BASIN/PIT DISPOSAL



NWI REGIONAL WELL



SHELL CHEMICAL WELL



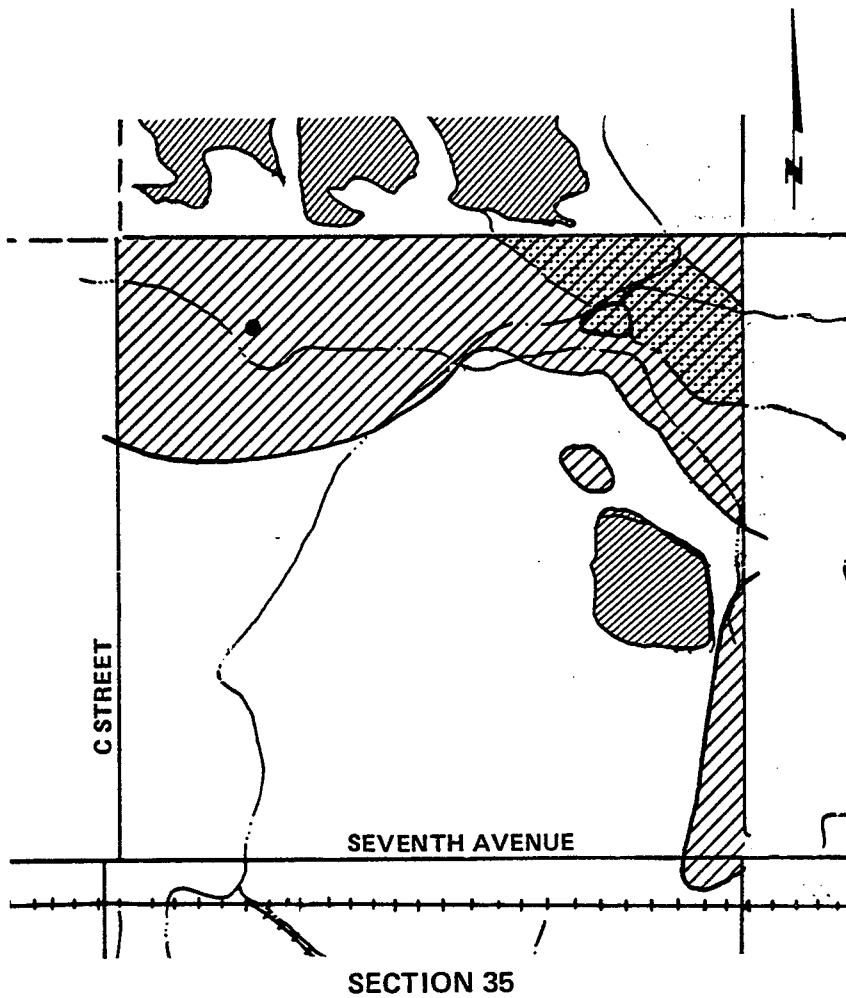

OTHER WELL

**SERIES A
LOCATION OF BORINGS AND
LINE OF SECTION**



LEGEND

SERIES C MAPS

- SHALLOW ABANDONED FARM WELL
-  LATERAL EXTENT OF PLUME, IF PRESENT
-  SURFACE STORAGE/DISPOSAL
-  BASIN/PIT DISPOSAL



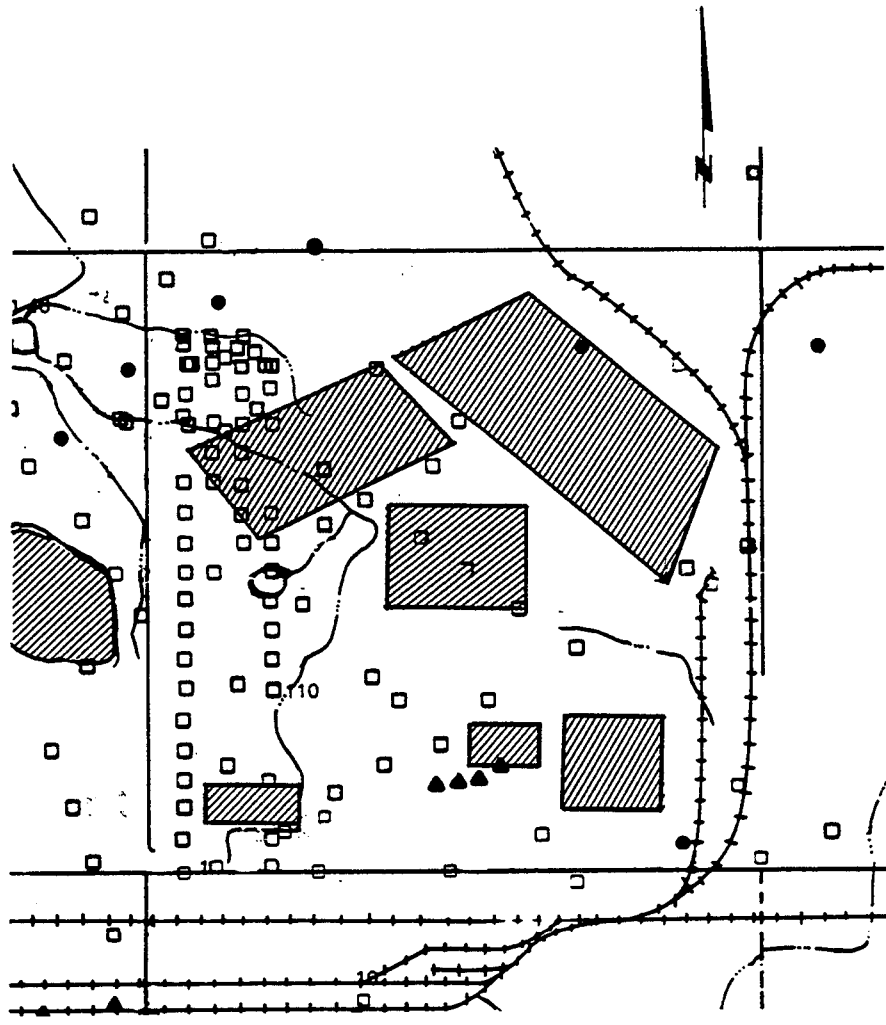



**SERIES C
ABANDONED FARM WELLS AND
CONTAMINANT PLUME**



SECTION 36

LEGEND

SERIES A MAPS

- 
LINE OF CROSS SECTION
- 
SURFACE STORAGE/DISPOSAL
- 
BASIN/PIT DISPOSAL
- 
NWI REGIONAL WELL
- 
SHELL CHEMICAL WELL
- 
OTHER WELL

**SERIES A
LOCATION OF BORINGS AND
LINE OF SECTION**

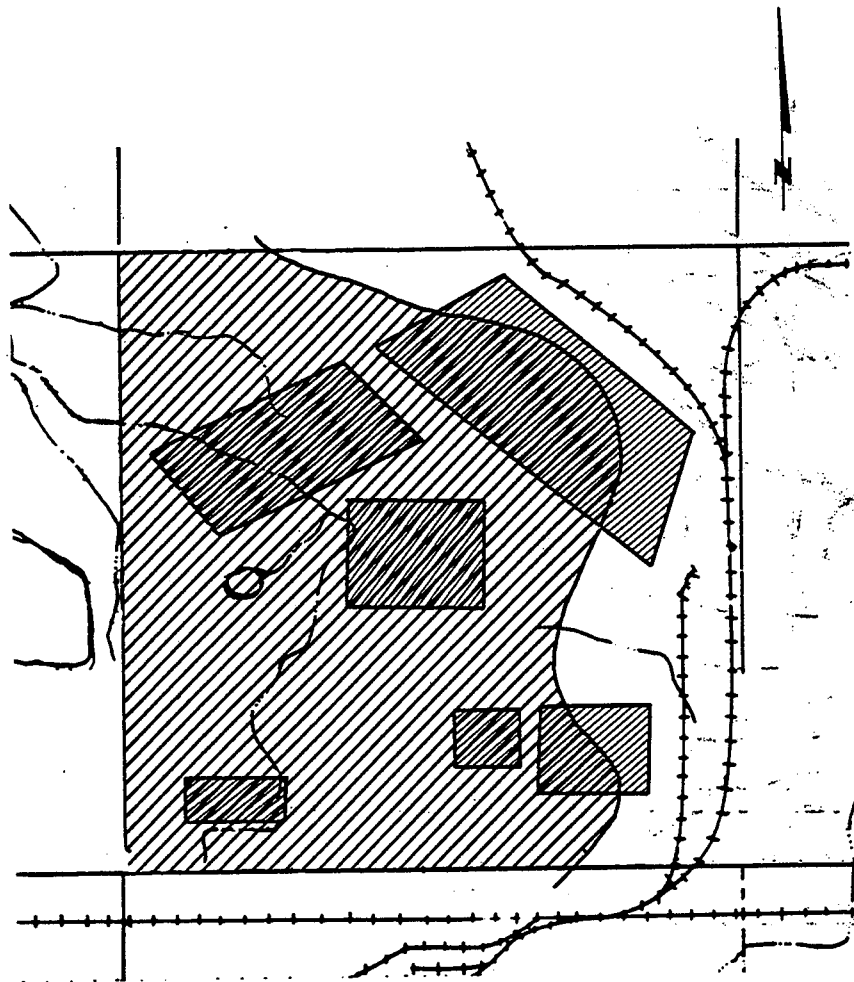

SECTION 36

LEGEND

LEGEND

SERIES C MAPS



LATERAL EXTENT OF PLUME, IF PRESENT



BASIN/PIT DISPOSAL

SERIES C
ABANDONED FARM WELLS AND
CONTAMINANT PLUME

BIBLIOGRAPHY

Asselin, Michael B., September 1977. Rocky Mountain Arsenal Source Treatment Plan Development System, Draft. Process Technology Branch, Munitions Division, Chemical Systems Laboratory, Aberdeen Proving Ground, Maryland.

Buhts, R. E., Francinques, N. R., Green, A. J., 1979. Basin F Investigative Studies, Report 2, Historical Review, U.S. Army Engineer Waterways Experiment Station, Vicksburg, Mississippi.

Cogley, David R., Grant, Donald C., and Hoover, Peter R., December, 1975. Report of Readily Available Data on 109 Compounds Associated with Shell Chemical Company Operations at Rocky Mountain Arsenal, Walden Research Division of Abcor, Inc., Cambridge, Massachusetts, Prepared for U.S. Army Bioengineering Research and Development Laboratory, Environmental Research Requirements Branch, Fort Detrick, Frederick, Maryland.

Department of the Army, November, 1973. Memo for Record: Survey of Buried Waste Plot, Rocky Mountain Arsenal, Denver, Colorado.

Department of the Army, May 1979. Quality Assurance Program for U.S. Army Toxic and Hazardous Materials Agency, U.S. Army Toxic and Hazardous Material Agency, Aberdeen Proving Ground, Maryland.

Department of the Army, - . Safety Planning for Installation Restoration Surveys and Projects, U.S. Army Toxic and Hazardous Materials Agency, Aberdeen Proving Ground, Maryland.

Geraghty & Miller, Inc., July 1979. Fourth Interim Report Hydrogeologic Description of Rocky Mountain Arsenal Ground-water Module, Prepared for Arthur D. Little, Inc.

Geraghty & Miller, Inc., 1981. Evaluation of the Hydrogeologic System and Contamination Migration Patterns, Rocky Mountain Arsenal, Denver, Colorado. Prepared for U.S. Army Toxic and Hazardous Materials Agency, Aberdeen Proving Ground, Maryland.

Geraghty & Miller, Inc., October, 1981. Summary Document Contract DAAK 11-80-C-0095, Prepared for U.S. Army Toxic and Hazardous Materials Agency, Aberdeen Proving Ground, Maryland.

Kolmer, Joseph R., July, 1979. Rocky Mountain Arsenal, Groundwater Quality Analysis, Environmental Engineering Laboratory, U.S. Army Engineer, Waterways Experiment Station, and Rocky Mountain Arsenal. Prepared for U.S. Army Toxic and Hazardous Materials Agency, Aberdeen Proving Ground, Maryland.

Konikow, Leonard F., 1977. Modeling Chloride Movement in the Alluvial Aquifer at the Rocky Mountain Arsenal, Colorado. Geological Survey Water Supply Paper 2044.

Konikow, Leonard F. and Thompson, Douglas W., - . Ground-water Contamination and Aquifer Reclamation at the Rocky Mountain Arsenal, Colorado. U.S. Geological Survey, Water Resources Division, Reston, Virginia; and U.S. Army Corps of Engineers, Waterways Experiment Station, Vicksburg, Mississippi.

May, James H., February, 1982. Hydrogeology of Rocky Mountain Arsenal, Colorado, Working Draft. Geotechnical Laboratory, U.S. Army Engineer Waterways Experiment Station, Vicksburg, Mississippi. Prepared for U.S. Army Toxic and Hazardous Materials Agency, Aberdeen Proving Ground, Maryland.

MITRE Corporation, 1981. Site Ranking Model for Determining Remedial Action Priorities Among Uncontrolled Hazardous Substance Facilities, Draft Report to U.S. Environmental Protection Agency, Project No. 1067E.

National Space Technology Laboratories, February, 1982. Information Management Plan for Rocky Mountain Arsenal, Commerce City, Colorado. Engineering Laboratory Computer Sciences Corporation, National Space Technological Laboratories, Mississippi. Prepared for U.S. Army Armament Research and Development Command Resident Operations Office.

Robson, S. G., June 1977. Digital-Model Study of Ground-water Contamination by Diisopropylmethylphosphonate (DIMP), Rocky Mountain Arsenal, Denver, Colorado, Final Report. U.S. Geological Survey Administrative Report, Prepared for U.S. Department of the Army, Rocky Mountain Arsenal.

Rocky Mountain Arsenal Contamination Control Study Team, August, 1981. Combination Control Strategies for Rocky Mountain Arsenal, Interim Report. Prepared for U.S. Army Toxic and Hazardous Materials Agency, Aberdeen Proving Ground, Maryland.

Rocky Mountain Arsenal Special Projects Division,
April 1970. Location of Discarded TX, Rocky
Mountain Arsenal, Denver, Colorado. Prepared for
Mr. Thomas Dashiell, AMXFD-DS, Fort Detrick,
Frederick, Maryland.

Rosenblatt, David H. et al, 1975. Problem
Definition Studies on Potential Environmental
Pollutants: I. Toxicology and Ecological Hazards
of 16 Substances at Rocky Mountain Arsenal. U.S.
Army Medical Biengineering Research and Development
Laboratory, Fort Detrick, Frederick, Maryland.

Thorne, David S., et al, July 1979. Biological
Monitoring of Pesticides, Heavy Metals and Other
Contaminants of Rocky Mountain Arsenal. Phase I.
Department of the Army, Rocky Mountain Arsenal,
Commerce City, Colorado.