

REPORT DOCUMENTATION PAGE

Form Approved
OMB No. 0704-0188

Public reporting burden for this collection of information is estimated to average 1 hour per response, including the time for reviewing instructions, searching existing data sources, gathering and maintaining the data needed, and completing and reviewing the collection of information. Send comments regarding this burden estimate or any other aspect of this collection of information, including suggestions for reducing this burden, to Washington Headquarters Services, Directorate for Information Operations and Reports, 1215 Jefferson Davis Highway, Suite 1204, Arlington, VA 22202-4302, and to the Office of Management and Budget, Paperwork Reduction Project (0704-0188), Washington, DC 20503.

1. AGENCY USE ONLY (Leave blank)	2. REPORT DATE November 1994	3. REPORT TYPE AND DATES COVERED
----------------------------------	---------------------------------	----------------------------------

4. TITLE AND SUBTITLE Analysis of Adiabatic Shear Bands in Thermoviscoplastic Materials Under Combined Loading	5. FUNDING NUMBERS DAALO3-92-G-0131
---	--

6. AUTHOR(S) Romesh C. Batra	<p style="text-align: center; font-size: 2em; font-weight: bold;">S DTIC ELECTE FEB 10 1995 G D</p>
---------------------------------	---

7. PERFORMING ORGANIZATION NAME(S) AND ADDRESS(ES) University of Missouri-Rolla Rolla, MO 65401-0249	8. PERFORMING ORGANIZATION REPORT NUMBER
--	--

9. SPONSORING/MONITORING AGENCY NAME(S) AND ADDRESS(ES) U. S. Army Research Office P. O. Box 12211 Research Triangle Park, NC 27709-2211	10. SPONSORING/MONITORING AGENCY REPORT NUMBER ARO 29907.1-EG-AAS
---	--

11. SUPPLEMENTARY NOTES
The view, opinions and/or findings contained in this report are those of the author(s) and should not be construed as an official Department of the Army position, policy, or decision, unless so designated by other documentation.

12a. DISTRIBUTION/AVAILABILITY STATEMENT Approved for public release; distribution unlimited.	12b. DISTRIBUTION CODE
--	------------------------

ABSTRACT (Maximum 200 words)

We study the initiation and growth of adiabatic shear bands in a thin-walled steel tube deformed first quasistatically either in simple compression or simple tension or by a pressure applied to the inner surface of the tube and then one end of the tube is kept fixed and the other end is twisted with a prescribed tangential speed. The objective is to see how prior quasistatic deformations of the tube affect the nominal shear strain at which a shear band initiates in the tube. The first set of numerical experiments simulates tests recently conducted by Murphy who found that the nominal strain at the initiation of the shear bands decreased with an increase in the axial static compressive stress induced in the tube.

19950203 291

14. SUBJECT TERMS Combined loading, adiabatic shear bands	15. NUMBER OF PAGES 13
--	---------------------------

		16. PRICE CODE
--	--	----------------

17. SECURITY CLASSIFICATION OF REPORT UNCLASSIFIED	18. SECURITY CLASSIFICATION OF THIS PAGE UNCLASSIFIED	19. SECURITY CLASSIFICATION OF ABSTRACT UNCLASSIFIED	20. LIMITATION OF ABSTRACT UL
---	--	---	----------------------------------

TABLE OF CONTENTS

I. STATEMENT OF THE PROBLEM STUDIED	1
II. BRIEF REVIEW OF THE COMPLETED WORK.....	2
III. DEGREES AWARDED	12
IV. PARTICIPATING SCIENTIFIC PERSONNEL	12
V BIBLIOGRAPHY	13

Accession For	
NTIS CRA&I	<input checked="" type="checkbox"/>
DTIC TAB	<input type="checkbox"/>
Unannounced	<input type="checkbox"/>
Justification	
By	
Distribution /	
Availability Codes	
Dist	Avail and/or Special
A-1	

I. STATEMENT OF THE PROBLEM

Adiabatic shear bands are narrow regions, usually a few microns wide, of intense plastic deformation that form during high strain-rate plastic deformation of most metals. Tresca¹ seems to be the first to observe these during the hot forging of platinum and he termed these "hot lines". Subsequently Massey² also noticed these during the hot forging process. However, the research activity in this area appears to be influenced strongly by the work of Zener and Hollomon³ who observed 32 μm wide shear bands during the punching of a hole in a steel plate. They also pointed out that the intense plastic deformations of the steel heated it up significantly and that it became unstable when the thermal softening equalled the hardening caused by strain and strain-rate effects. The reader is referred to Rogers⁴, Clifton⁵, Olson *et al.*⁶, and to recent issues of the Applied Mechanics Reviews⁷ and the Mechanics of Materials Journal⁸ for a review of the work in this area.

The experimental work under controlled conditions has been performed on tubular specimens using a Kolsky bar by Duffy and his students^{9,10} and Giovanola¹¹. These tests have involved the twisting of a thin tube, observing deformations of a grid pasted on the outer surface of the tube and using infrared lamps to measure the temperature rise of a small region either included in or enclosing the shear band. Such observations have enhanced significantly our understanding of the mechanism of the shear band formation. Recently Murphy¹² conducted a series of tests in which a steel tube was loaded quasistatically in simple compression and then twisted dynamically. He found that an increase in the prior compressive load increased the nominal strain at which a shear band initiated.

In many practical problems such as those encountered in manufacturing processes and the penetration of a deformable rod into a steel target, the stress-state at a point is quite complicated. Since shear bands are believed to precede shear fractures in these problems, it is important to investigate their initiation and growth under combined loading.

BRIEF REVIEW OF THE COMPLETED WORK

Mr. Mark Lanham worked on the project during the period 1 June 1992 through 30 November 1992. He conducted literature survey and established sufficient background to begin conducting some meaningful research. However, he decided to withdraw from school. In response to an advertisement in Mechanical Engineering, Mr. Forrest Flocker was recruited to work on the project. He was supported during the academic year 1993-94 but because of a rather heavy course work, he could not devote much time to research. The PI accepted a position at the Virginia Tech beginning Fall 1994, and upon his request, the project was terminated effective 5 July 1994. Another student, partially supported by the parent grant, worked on a similar problem and the results reported below were obtained with his help.

We have studied the dynamic twisting of a steel tube preloaded quasistatically either in simple tension, or simple compression or by an internal pressure. The maximum preload applied is such as not to cause plastic deformations of the tube. The material of the tube is modeled by the Johnson-Cook¹³ relation for which the effective stress σ_e is given by

$$\sigma_e = (A + B(\epsilon_p)^n) (1 + D \ln(\dot{\epsilon}_p/\dot{\epsilon}_o)) (1 - \nu\theta) \quad (1)$$

where A, B, n, D, ν are material parameters, ϵ_p is the effective plastic strain, $\dot{\epsilon}_p$ the effective plastic strain-rate, $\dot{\epsilon}_o$ the reference value of the effective plastic strain-rate usually taken as 1/sec, and θ is the temperature rise of a material particle. The tube is taken to be initially stress free, and at rest at a uniform temperature.

The preload is applied slowly with a rise time of $20\mu\text{s}$ and is held constant for $30\mu\text{s}$ for the waves to dissipate out. One end of the tube is kept fixed and the other end is twisted so as to produce the desired nominal strain-rate of 5000/sec. The thickness of the tube is assumed to vary sinusoidally with the smallest thickness occurring at the central cross-section of the tube as shown in Fig. 1. The values of material parameters for the 4340 steel are taken from Rajendran's¹⁴ report.

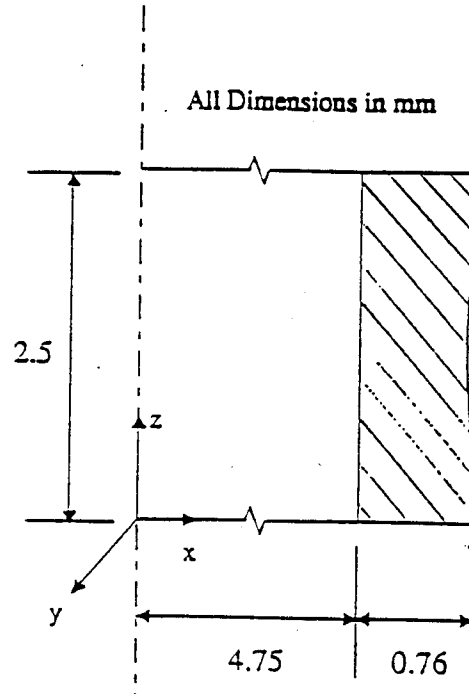

Figure 1 - Tube Geometry.

For the case when the tube is first axially loaded quasistatically either in compression or in tension and then twisted, Figs. 2 and 3 illustrate the torque versus average shear strain curves for four different values of the axial load. Note that the maximum axial stress applied equals 45% of the value of the material parameter A appearing in Eq. 1. Because of the prestress, the shear stress and hence the torque required to initiate yielding should be less than that necessary when there is no prestress applied. Results plotted in Figs. 2 and 3 confirm this. The average shear strain at which a shear band initiates, as indicated by the drop in the torque required to deform the tube, increases with an increase in the magnitude of the axial compressive prestress and the reverse happens when the prestress is tensile. This trend contradicts the experimental observations of Murphy¹² who reported that the average shear strain at the instant of the initiation of a shear band decreased with an increase in the magnitude of the axial compressive prestress. A close examination of the deformed shape of

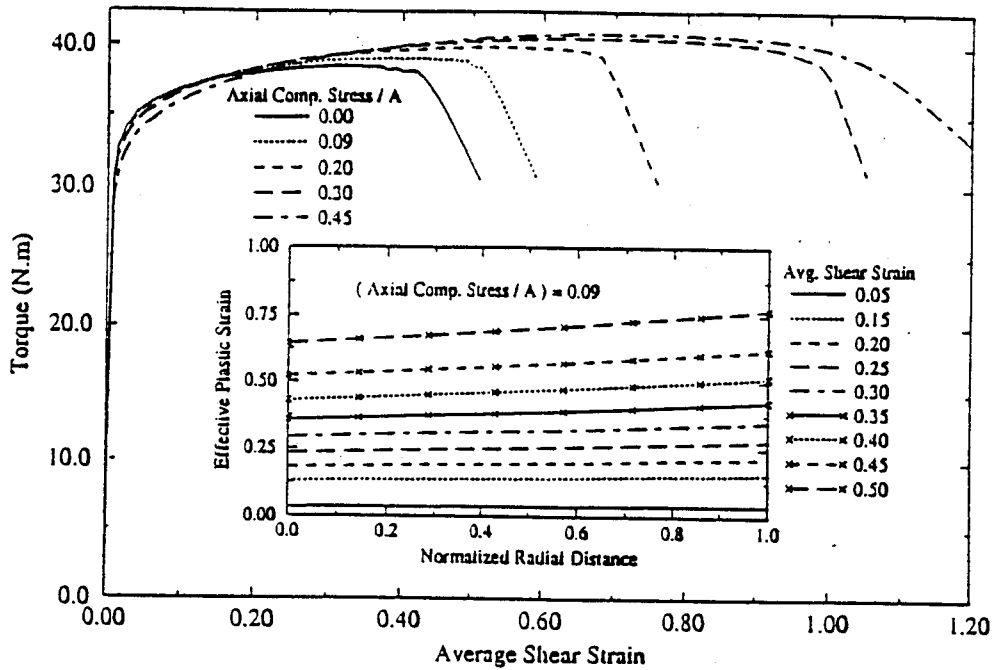

Figure 2 - Torque vs. average shear strain curves for five different values of the initial axial compressive stress. The Insert shows the distribution of the effective plastic strain, at different times, on a radial line in the thinnest cross-section.

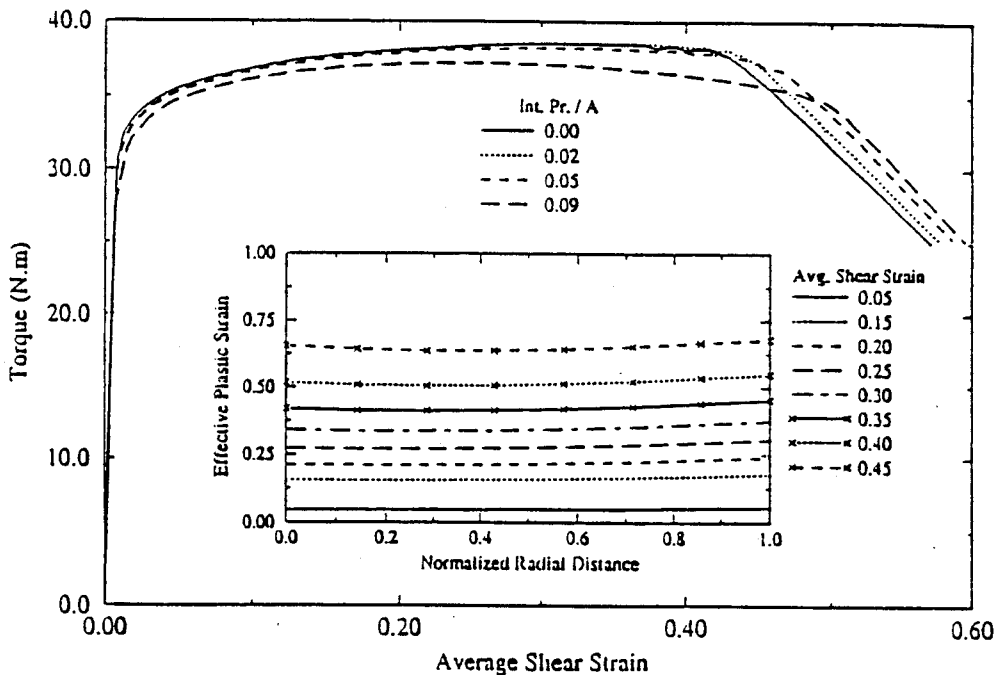

Figure 3 - Torque vs. average shear strain curves for four different values of the initial axial tensile stress. The insert depicts the distribution of the effective plastic strain, at different times, on a radial line in the thinnest cross-section.

the tube indicated significant radial displacements of points on the central cross-section; for example, see Fig. 4. The inserts in Figs. 2 and 3 depict the distribution of the effective plastic strain on a radial line in the thinnest section of the tube. It is clear that deformations of the tube are nonhomogeneous with the largest effective plastic strain occurring at points on the outermost surface of the tube. For axial prestress equal to $0.09A$, the shear band initiates at average shear strains of 0.48 and 0.37 for the compressive and tensile cases; however, the distribution of the effective plastic strain along the radial direction is essentially the same in the two cases. The severe deformations of the central cross-section result in an increase of the cross-sectional area for tubes prestressed in compression and in a decrease of the cross-sectional area for tubes preloaded in tension. This change in the cross-sectional area delays the initiation of the shear band for the tube prestressed in compression and enhances the initiation of the shear band in the tube prestressed in tension. We note that the axial length of the tube decreases (increases) for the tube prestressed in compression (tension). It is not clear whether Murphy's experimental setup allowed for this change in the axial length of the specimen. For the case of no preload, the tube length, the inner radius, and the outer radius remained unchanged.

We simulated a case when one end of the tube was held fixed and at the other end the axial component of velocity was first increased linearly from zero to the desired value in $20 \mu s$ so as to induce an axial compressive stress in the tube by the desired amount. Subsequently, the axial component of velocity was decreased to zero and a tangential component of velocity was prescribed. This type of boundary data resulted in a gradual decrease of the axial compressive stress to zero. Analysis of the quasistatic problem involving a cylinder subjected to compressive and torsion loads given in Ref. 15 suggests that this trend is consistent with the predictions of the Prandl-Reuss theory of plasticity.

Figure 5 depicts the evolution of the effective plastic strain on an axial line on the outer surface of the tube obtained by using a fine mesh. It is evident that deformations are nonhomogeneous even at an average shear strain of 0.05 and this nonhomogeneity in the

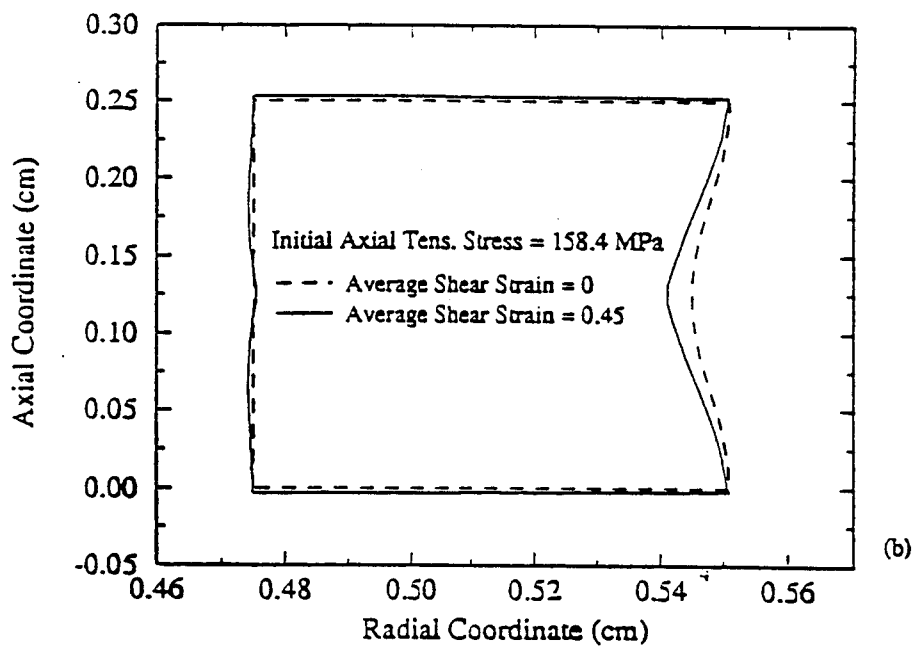
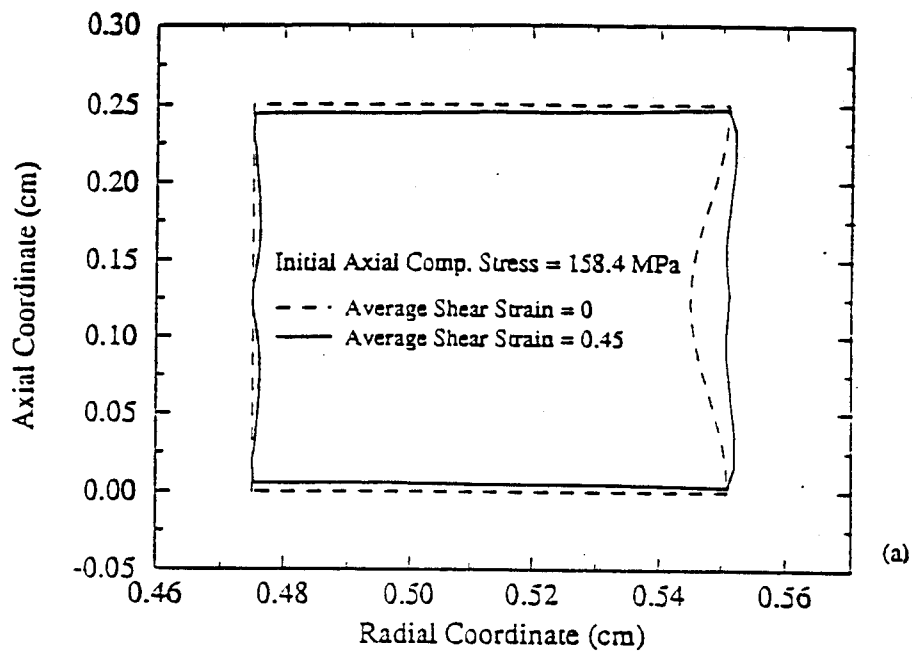

Figure 4 - Sections of the deformed tubes initially prestressed in (a) compression and (b) tension.

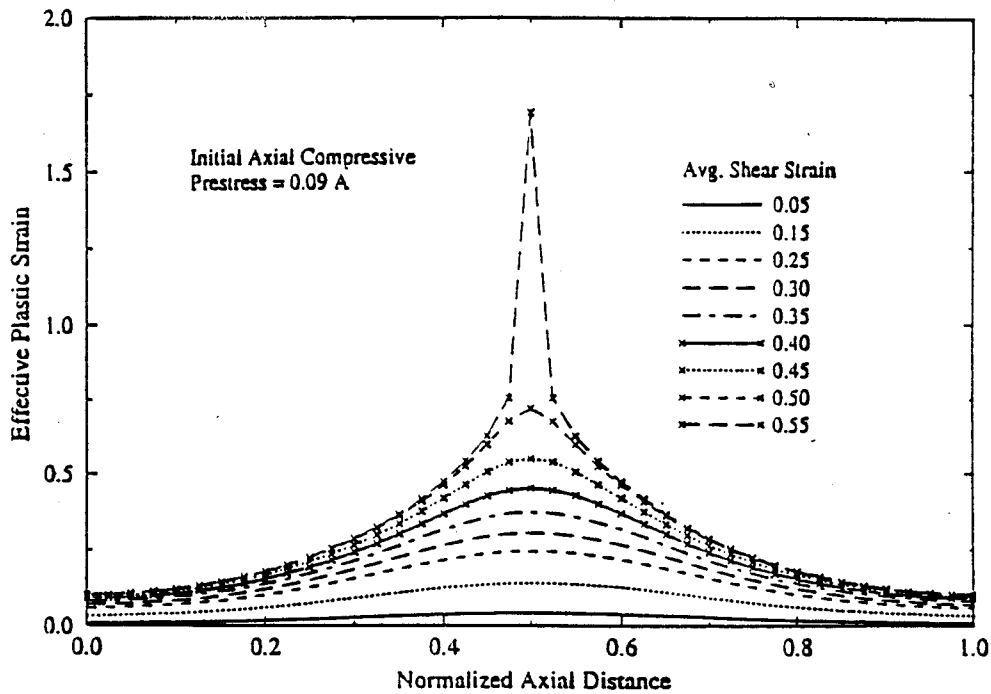

Figure 5 - Distribution of the effective plastic strain at different times on a line parallel to the axis of the tube passing through the outermost point of the thinnest cross-section.

deformations increases as the tube continues to be twisted. Eventually the deformations localize into the central element. Once it happens, the material outside of this element does not undergo any more plastic deformations, and some parts may even unload. The width of the region of localization cannot be deciphered accurately since the mesh used is not fine enough. For this reason, the computations were stopped soon after the torque required to deform the tube began to drop.

Effect of Initial Internal Pressure

We assume that the end surfaces are held fixed in the axial direction and an internal pressure is applied slowly to the tubular specimen. Even when the internal pressure applied was 713 MPa, the stress state at a point was such as not to cause any yielding of the material. Subsequently, with the internal pressure held steady, the end surfaces are twisted in equal and opposite directions by applying tangential velocity on them so as to induce an average

shear strain-rate of 5000 s^{-1} . In Fig. 6 we have plotted the torque required to deform the tube versus the average shear strain. As expected with an increase of the internal pressure the shear stress and hence the torque when the tube begins to deform plastically decrease. However, the average shear strain at which a shear band initiates increases with an increase in the value of the internal pressure because of an increase in the inner and outer radii of the tube. Figure 7 illustrates the distribution, on a radial line, of the effective plastic strain at different times. Whereas initially the effective plastic strain is a little higher at points on the outermost surface than that at points on the innermost surface, the reverse happens after the shear band has initiated. Also, the variation of the effective plastic strain in the radial direction is not linear as was the case for the tube prestressed in axial tension or compression. Figure 8 depicts the deformed sections of the tube just before the torque is applied and when the average strain equals 0.45. It is clear that significant radial displacements of material points occur during the time the tube is being twisted.

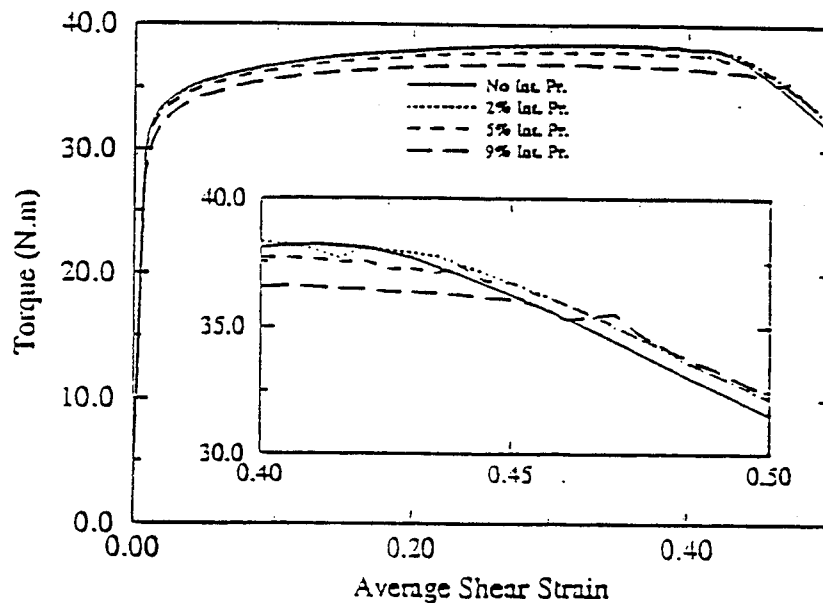

Figure 6 - Torque vs. average shear strain curves for four different values of the internal pressure

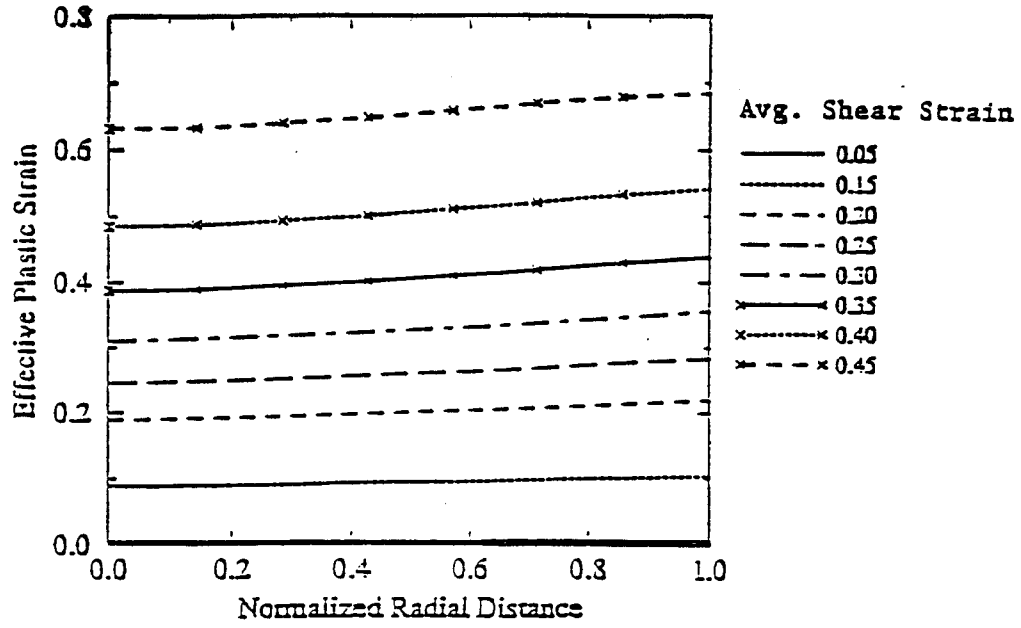

Figure 7 - The distribution of effective plastic strain, at different times, on a radial line in the thinnest cross-section.

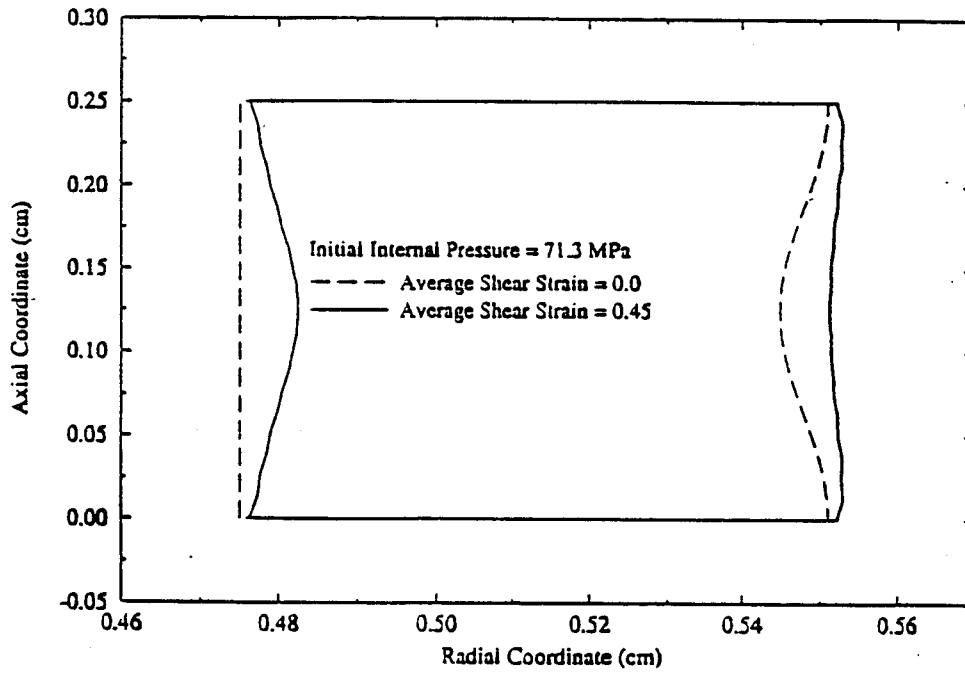

Figure 8 - Sections of the deformed tube

III. DEGREES AWARDED

None

IV. PARTICIPATING SCIENTIFIC PERSONNEL

Mark Lanhan (6/92 - 11/92)

Forrest Flocker (8/93 - 5/94).

V. BIBLIOGRAPHY

1. Tresca, H., "On Further Application of the Flow of Solids," *Proceedings of the Institute of Mechanical Engineers*, Vol. 30, 1878, pp. 301-345.
2. Massey, H.F., "The Flow of Metal during Forging," *Proceedings of the Manchester Association of Engineers*, pp. 21-26 (1926).
3. Zener, C. and Hollomon, J.H., "Effect of Strain Rate on Plastic Flow of Steel," *Journal of Applied Physics*, Vol. 14, 1944, pp. 22-32.
4. Rogers, H.C., "Adiabatic Plastic Deformation," *Annual Review of Material Science*, Vol. 9, 1979, pp. 299-311.
5. Clifton, R.J., "Adiabatic Shear Banding, *Material Response to Ultra-High Loading Rates*," NRC Report NMAB-356, 1980, pp. 129-142.
6. Olson, G.B., Mescall, J.F., and Azrin, M., "Adiabatic Deformation and Strain Localization," in *Shock Waves and High Strain-Rate Phenomenon in Metals*, M.A. Meyers and L.E. Murr (eds.), Plenum Press, NY, 1980, pp. 221-247.
7. Zbib, H.M., Shawki, T., and Batra, R.C. (eds.), *Materials Instabilities*, Special Issue of *Applied Mechanics Reviews*, Vol. 45, No. 3, March 1992, pp. S1-S173.
8. Armstrong, R., Batra, R.C., Meyers, M.A., and Wright, T.W. (guest editors), Special Issue on Shear Instabilities and Viscoplasticity Theories, *Mechanics of Materials*, Vol. 17, 1994, pp. 83-327.
9. Hartley, K.A., Duffy, J., and Hawley, R.H., "Measurement of the Temperature Profile During Shear Band Formation in Steels Deforming at High Strain Rates," *Journal of the Mechanics and Physics of Solids*, Vol. 35, 1987, pp. 283-301.
10. Marchand, A. and Duffy, J., "An Experimental Study of the Formation Process of Adiabatic Shear Bands in a Structural Steel," *Journal of the Mechanics and Physics of Solids*, Vol. 36, 1988, pp. 251-283.
11. Giovanola, J.H., "Adiabatic Shear Banding Under Pure Shear Loading - Part I: Direct Observation of Strain Localization and Energy Dissipation Measurements," *Mechanics of Materials*, Vol. 7, 1988, pp. 59-72.

12. Murphy, B.P., *Shear Band Formation in a Structural Steel Under a Combined State of Stress*, M.Sc. Thesis, Brown University, Providence, RI 1990.
13. Johnson, G.R. and Cook, W.H., "A Constitutive Model and Data for Metals Subjected to Large Strains, High Strain Rates, and High Temperatures," *Proceedings of the 7th International Symposium on Ballistics*, The Hague, The Netherlands, 1983, pp. 541-548.
14. Rajendran, A.M., *High Strain Rate Behavior of Metals, Ceramics, and Concrete*, Report #WL-TR-92-4006, Wright Patterson Air Force Base, OH 1992.
15. Chakrabarty, J., *Theory of Plasticity*, McGraw Hill Book Co., NY, 1987.