

# REPORT DOCUMENTATION PAGE

Form Approved  
OMB No. 0704-0188

Public reporting burden for this collection of information is estimated to average 1 hour per response, including the time for reviewing instructions, searching existing data sources, gathering and maintaining the data needed, and completing and reviewing the collection of information. Send comments regarding this burden estimate or any other aspect of this collection of information, including suggestions for reducing this burden, to Washington Headquarters Services, Directorate for Information Operations and Reports, 1215 Jefferson Davis Highway, Suite 1204, Arlington, VA 22202-4302, and to the Office of Management and Budget, Paperwork Reduction Project (0704-0188), Washington, DC 20503.

1. AGENCY USE ONLY (Leave blank)	2. REPORT DATE 08/28/80	3. REPORT TYPE AND DATES COVERED
----------------------------------	----------------------------	----------------------------------

4. TITLE AND SUBTITLE REMOVAL OF EXCESS FLUORIDE FROM ACTIVATED CARBON EFFLUENT, FINAL REPORT, PILOT TEST PROGRAM	5. FUNDING NUMBERS
--	--------------------

6. AUTHOR(S)	DAAA05 79 C 006
--------------	-----------------

7. PERFORMING ORGANIZATION NAME(S) AND ADDRESS(ES)  RUBEL & HAGER, INC. TUCSON, AZ	8. PERFORMING ORGANIZATION REPORT NUMBER  81324R22
---	--

9. SPONSORING/MONITORING AGENCY NAME(S) AND ADDRESS(ES)  ROCKY MOUNTAIN ARSENAL (CO.) COMMERCE CITY, CO	10. SPONSORING/MONITORING AGENCY REPORT NUMBER
--	--

DTIC  
ELECTE  
JAN 31 1995  
S G D

11. SUPPLEMENTARY NOTES
-------------------------

12a. DISTRIBUTION/AVAILABILITY STATEMENT  APPROVED FOR PUBLIC RELEASE; DISTRIBUTION IS UNLIMITED	12b. DISTRIBUTION CODE
--	------------------------

13. ABSTRACT (Maximum 200 words)  THE WORK REPORTED HEREIN IS THE FINAL PHASE OF A TECHNICAL DEVELOPMENT PROGRAM TO IDENTIFY AN ECONOMICALLY FEASIBLE SOLUTION TO THE REMOVAL OF EXCESS FLUORIDE FROM ACTIVATED CARBON TREATED GROUND WATER AT THE NORTH BOUNDARY OF RMA. THE OBJECTIVES OF THE FINAL PHASE OF THE PROGRAMS WERE: (1) TO DEMONSTRATE THE CALCIUM FLUORIDE PRECIPITATION PROCESS OVER A NUMBER OF CYCLES OF ACTIVATED ALUMINA REGENERATIONS (2) TO EVALUATE THE POTENTIAL RE-USE OF THE SUPERNATANT WASTE WATER REMAINING AFTER PRECIPITATION FOR SUBSEQUENT REGENERATION FLUID AND (3) TO REDUCE THE TOTAL VOLUME OF REGENERANT FLUIDS WHICH HERETOFORE AMOUNTED TO 3% OF RAW WATERFLOW.  <p style="text-align: center; font-weight: bold;">DTIC QUALITY INSPECTED 3</p>
--

14. SUBJECT TERMS  WATER RECYCLE, COST, TREATMENT	15. NUMBER OF PAGES
	16. PRICE CODE

17. SECURITY CLASSIFICATION OF REPORT UNCLASSIFIED	18. SECURITY CLASSIFICATION OF THIS PAGE	19. SECURITY CLASSIFICATION OF ABSTRACT	20. LIMITATION OF ABSTRACT
---	--	---	----------------------------

Copy # \_\_\_\_\_

81324R22  
Original

FINAL REPORT  
PILOT TEST PROGRAM

REMOVAL OF EXCESS FLUORIDE  
FROM  
ACTIVATED CARBON EFFLUENT

Submitted August 28, 1980

Rocky Mountain Arsenal  
Information Center  
Commerce City, Colorado

FOR

DEPARTMENT OF THE ARMY  
ROCKY MOUNTAIN ARSENAL  
CONTRACT # DAAA05-79-C-006.  
AS AMENDED P 00005  
APRIL 30, 1980

19950127 152

By

Rubel and Hager, Inc.  
4400 East Broadway  
Tucson, Arizona

Accession For	
NTIS CRA&I	<input checked="" type="checkbox"/>
DTIC TAB	<input type="checkbox"/>
Unannounced	<input type="checkbox"/>
Justification _____	
By _____	
Distribution / _____	
Availability Codes	
Dist	Avail and/or Special
A-1	

Copies: 1 - 6 Carl Loven  
7 - 9 Rubel & Hager, Inc.

FILE COPY



REPLY TO  
ATTENTION OF:

DEPARTMENT OF THE ARMY

ROCKY MOUNTAIN ARSENAL  
COMMERCE CITY, COLORADO 80022

SARRM-TOE-T

2 Aug 80

SUBJECT: Transmittal of Rubel and Hager Report

Commander  
US Army Toxic & Hazardous  
Materials Agency  
ATTN: DRXTH-IS  
Aberdeen Proving Ground, Maryland 21010

Inclosed is a copy of Rubel and Hager's "Removal of Excess Fluoride  
from Activated Carbon Effluent," dated 28 Aug 80.

FOR THE COMMANDER:

1 Incl  
as

WILLIAM MCNEILL  
Acting Director  
Technical Operations

*File  
as  
report*

TABLE OF CONTENTS

	<u>PAGE</u>
INTRODUCTION AND OBJECTIVES	1
TEST APPARATUS AND PROGRAM	2
TEST RESULTS	3
PROJECTED CHEMICAL COSTS FOR WATER RECYCLE	6
CONCLUSIONS	9
APPENDICES	
A. RELATED REFERENCES	10
B. TEST APPARATUS AND PROGRAM (DETAILED)	11
C. TREATMENT DATA	14
D. REGENERATION DATA	22

## INTRODUCTION

The work reported herein is the final phase of a technical development program to identify an economically feasible solution to the removal of excess fluoride from activated carbon treated ground water at the North Boundary of the Rocky Mountain Arsenal (RMA). Previous reports describing this program are listed in Appendix A - Related References and can be summarized as follows to describe the techno-economic status of fluoride removal at RMA prior to the final phase.

1. A treatment process employing activated alumina is capable of reducing fluoride ions in the activated carbon effluent to levels below the EPA maximum contamination level (MCL) for the Denver region of 2.4 mg/l.

2. Capital costs for a 1,000 gpm activated alumina system are projected to be \$270,000. Operating costs are projected to be 14.3 cents per 1,000 gallons. These cost projections were valid as of 1979.

3. Approximately 3% of the raw water flow is used to periodically regenerate and clean the activated alumina. Existing full scale facilities utilizing the activated alumina process presently lagoon this waste water. For RMA, waste water would amount to 26,000 gallons per day at an average treatment flow of 600 gpm.

4. Laboratory testing of the waste water from the fluoride removal test unit operating at RMA indicated that calcium chloride precipitation could concentrate the fluoride ions into an estimated sludge volume of 480 gallons per day (1.5% solids) for a 600 gpm water flow.

## OBJECTIVES

The objectives of the final phase of the program were (1) to demonstrate the calcium fluoride precipitation process over a number of cycles of activated alumina regenerations (2) to evaluate the potential re-use of the supernatant waste water remaining after precipitation for subsequent regeneration fluid and (3) to reduce the total volume of regenerant fluids which heretofore amounted to 3% of raw water flow.

## TEST APPARATUS

The testing apparatus was a trailer mounted system capable of treating 5 gpm of water at 50 psig maximum working pressure. One column containing 3.75 cubic feet of activated alumina (Alcoa F-1) was employed for the fluoride removal step. This system which additionally included pH modification equipment was used in previous investigations of fluoride removal at RMA. A detailed description of the test apparatus is reproduced from earlier reports in Appendix B.

## TEST PROGRAM

The scope of the test program included eight (8) fluoride reduction treatment cycles comprised of (1) pumping the activated carbon treated water at a flow rate of 5 gpm through the activated alumina bed while maintaining the effluent water pH at 5.5 and (2) periodic removal of the accumulated fluoride from the alumina by pumping caustic regeneration water and rinse water through the alumina in both an upflow and downflow sequence. A complete description of the fluoride removal and regeneration sequences which were developed and reported in earlier RMA tests has been included in Appendix B. The only exception in this fluoride removal sequence was Test #7 in which the pH was not controlled and ranged between 7 - 8.

Beginning with Test #8 and continuing through Test #13, the regeneration fluids were first collected in 50 gallon drums and after sampling, were then transferred to a 1,000 gallon holding tank. The composite fluids were thoroughly mixed and calcium chloride was added during mixing at a dosage of 500 mg/l. After thirty (30) minutes of mixing, sulfuric acid was added to lower the pH to 6.5. Mixing was continued for thirty minutes after a pH of 6.5 was reached. The calcium fluoride was allowed to settle for at least one hour. The supernatant was then re-used in subsequent regenerations for the following uses.

1. upflow caustic solution
2. upflow rinse water
3. downflow caustic solution

For the final downflow rinse in each regeneration sequence, softened raw influent water was used. In Tests 9 - 12, the upflow rinse (re-used) water was softened.

A summary of the testing variables follows:

TABLE 1  
SUMMARY  
TESTING VARIABLES

TEST #	FLUORIDE REMOVAL TREATMENT pH	REGENERATION FLUIDS			
		UPFLOW		DOWNFLOW	
		CAUSTIC WATER	RINSE WATER	CAUSTIC WATER	RINSE WATER
7	6-7	raw	softened raw	raw	softened raw
8	5.5 ± 0.25	raw	softened raw	raw	softened raw
9-12	5.5 ± 0.25	re-used	softened re-used	re-used	softened raw
13-14	5.5 ± 0.25	re-used	re-used	re-used	softened raw

Throughout the test program, water conservation procedures were used on the backwash and rinse cycles to minimize the total regenerant fluids which need to be treated or cycled.

#### TEST RESULTS

The raw data recorded during the eight (8) cycles of fluoride removal from the carbon system effluent water and subsequent regenerations of the activated alumina treatment beds are tabulated in Appendices C and D respectfully. A summary of these data follows:

TABLE 2  
FLUORIDE REMOVAL AND RECOVERY

TEST #	TREATMENT pH	TOTAL WATER TREATED (GALLONS)	TOTAL FLUORIDE REMOVED (GRAINS)	TOTAL FLUORIDE RECOVERED (GRAINS)
7	7-8	15510	2330	-
8	5.5	42540	6293	4289
9	5.5	47210	6568	4676
10	5.5	41700	5898	7051
11	5.5	41930	6077	6101
12	5.5	38685	5601	6539
13	5.5	42870	5787	8298
14	5.5	44620	6277	-
S/T 8-14 average	5.5	42489	6037	6159

In Test 7, a treatment pH of 7 - 8 was used for the fluoride removal process as compared with a pH of 5.5 for Tests 8 - 14. The higher pH resulted in the treatment of only 15,210 gallons of water compared with an average of 42,489 gallons treated in Tests 8 - 14 at the lower pH. Accordingly, only 2,330 grains of fluoride were removed compared with an average of 6,037 for the other tests.

The average removal of 6,037 grains per cycle using 3.5 cubic feet of activated alumina would amount to 1725 grains removed per cubic foot. This value can be compared to the 1700 - 1750 grains per cubic foot obtained in previous work (reported 11/30/79).

Beginning with Test 8 regeneration, the waste water was collected, treated with calcium chloride, acidified to a pH of 6.5 and re-used (supernatant) after the precipitation of calcium fluoride. The data in Table 2 clearly indicates that the re-use of waste water over and over in Tests 9 - 14 did not adversely affect the total gallons treated or the grains removed as compared with Test 8 which had been previously regenerated in Test 7 with fresh water.

The data presented in Table 3 summarizes the volumes of the various fluids utilized to backwash and regenerate the activated alumina in Tests 9 - 14.

TABLE 3  
BACKWASH AND REGENERATION FLUIDS

	GALLONS			
	#9	#10	#11	Average 9-11
Backwash	80	99	90	90
Upflow caustic and re-use plus downflow caustic	490	470	385	448
Downflow neutralization	250	230	275	252
TOTAL	820	799	750	790
Total treated water	47,210	41,700	41,930	43,613
% Total Regenerant Fluids/Treated Water				1.8%
% Water Re-use/Treated Water				1.0%
% Water to be Recycled (less sludge)				0.8%

These results can be compared to previous tests (11/30/79) as follows:

TABLE 4  
DISTRIBUTION OF WASTE WATER FLUIDS

(% of Raw Water Flow)

	<u>11/30/79 Report</u>	<u>Current Test Results</u>
1. Recycle to Head of Treatment Process (Backwash and Neutralization)	1%	-
Backwash and excess Supernatant recycle	-	0.76%
2. High Fluoride Waste Water (to lagoon)	2%	-
3. Sludge (to lagoon)	-	<u>0.04%</u>
	3%	0.80%
4. <u>Water Reused</u> within Regeneration Cycle	-	1.0%

Thus, the treated water increases from 97% of total raw water as previously reported, to 99.2% as a result of improved water management and waste water re-use.

A water flow diagram indicating the water recycling and re-use loops is shown in Figure 1.

Table 5 summarizes the fluoride concentrations in the waste water before and after chemical treatment and pH adjustment to remove fluoride by precipitation. Data is shown as determined by on-site testing, WES laboratories and MALD laboratories. The obvious differences in these data for the same samples illustrates the difficulty in analytical testing of concentrated waste waters. There is a discernable trend in the data indicating a build-up of fluoride concentration in the waste water as it was re-used over six (6) cycles. The data indicates an average reduction of fluoride concentration of 98.9 mg/l per treatment cycle. Using an average gallons of waste water of 700 (from Table 3) and an average fluoride removal of 6,037 grains (from Table 2) the expected reduction in fluoride concentration would be 146 mg/l to provide equilibrium. Thus, a fluoride build-up was occurring despite accurate analytical proof.

#### PROJECTED CHEMICAL COSTS FOR WATER RECYCLE

As shown in Figure 1, the total waste water to be treated is projected to be 13,820 gallons per day at a treatment level of 600 gpm. At a dosage of 500 mg/l of calcium chloride the costs are calculated as follows:

$$13,820 \times \frac{3.7 \text{ liters}}{\text{gallon}} \times \frac{0.5 \text{ gram}}{\text{liter}} \div \frac{454 \text{ grams}}{\text{pound}} \\ \times \frac{\$.10}{\text{pound}} = \$5.63 \text{ per day}$$

$$\$5.63 \div 848 = \$0.007 \text{ per 1,000 gallons of treated water}$$

The acid requirement to lower the pH of the waste water to a pH of 6.5 was determined to be 1.14 gallons of concentrated sulfuric acid per 1,000 gallons of waste water. Acid costs would be:

$$13.820 \times 1.14 \times \frac{\$.45}{\text{gallon}} = \$7.09 \text{ per day}$$

$$\$7.09 \div 848 = \$0.008 \text{ per 1,000 gallons of treated water}$$

It is projected that water recycled to the head of the treatment process will amount to 6,350 gallons at an average

FIGURE 1  
 WATER BALANCE  
 (600 gpm - 864,000 gallons/day)

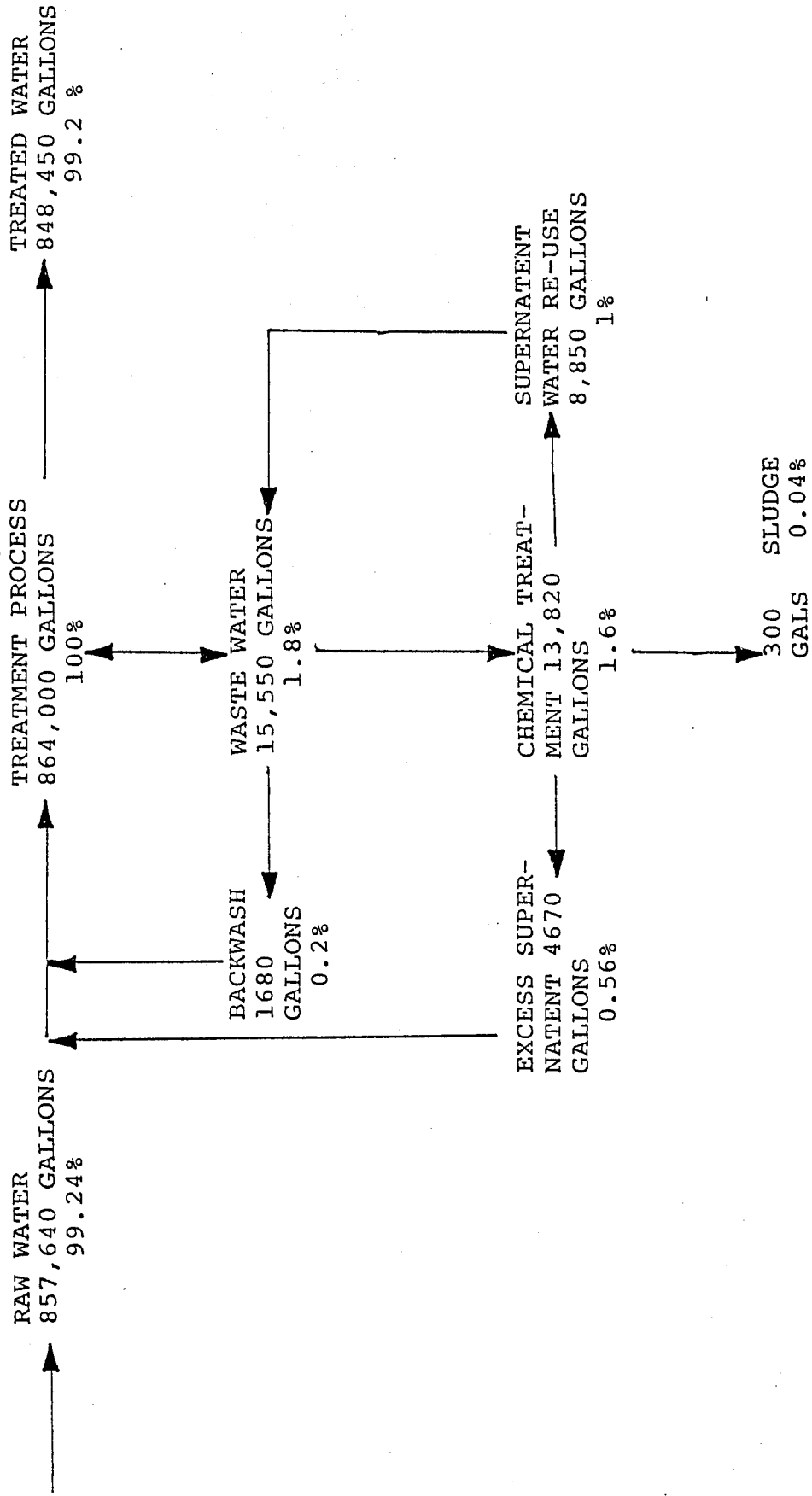

TABLE 5  
CALCIUM FLUORIDE PRECIPITATION

WASTE WATER			SUPERNATANT AFTER $\text{CoF}_2$ PRECIPITATION		NET FLUORIDE CONCENTRATION REDUCTION (mg/l)
REGENERATION #	PH	FLUORIDE CONCENTRATION (mg/l)	PH	FLUORIDE CONCENTRATION (mg/l)	
8	11.8	114 B	6.5	27 B	99
		130 M		19 B	
		122 A		23 A	
9	-	111 B	6.5	37 B	58.5
		130 M		85 W	
		119.5 A		61 A	
10	11.5	218 B	6.5	134 B	92
		229 M		129 M	
		222.5 A		131.5 A	
11	11.9	229 B	6.5	115 B	113
12	11.6	259 B	117 M		
		314 M	116 A		
13	11.7	286.5 A	6.5	83 M	203
		187 B		159 M	
		(194 ave)	6.5	(95.5 ave)	28
					(ave = 98.9)

B = Testing at Building 802  
M = Testing at MALD  
W = Testing at Waterways Experimental Station  
A = Average

fluoride concentration of 75 mg/l (4670 @ 100 mg/l plus 1680 @ 3.6 mg/l). On a total grains basis this would be equivalent to 136,000 gallons @ 3.6 mg/l fluoride. Therefore, this recycle cost can be projected as follows:

$$136 \times \$1.43 = \$19.45/\text{day}$$

$$\frac{\$19.45}{848} = \$0.023/1,000 \text{ gallons of water treated}$$

Total re-use and recycling chemical costs would therefore be:

	<u>\$1,000 Gallons Treated</u>
1. Calcium chloride	.006
2. pH reduction	.008
3. Recycle of excess supernatant and backwash water	<u>.023</u>
	\$.037
4. Sludge handling (300 + gallons per day)	not determined

#### CONCLUSIONS

1. Waste water from the activated alumina regeneration process was successfully re-used for six adsorption and regeneration cycles without measureable reduction in treatment efficiency.

2. Total water treated was increased to 99.2% of raw water flow from previously reported values of 97% (11/30/79) as a result of water re-use (1%) and lower total waste water generation (1.2%)

3. Of the 0.8% waste water to be handled, 0.76% can be recycled to the head of the treatment process and 0.04% contains the calcium fluoride sludge. (300 gallons per day)

4. Chemical costs for water re-use and waste water recycling are projected to be \$0.037 per 1,000 gallons treated.

5. Total treatment costs for fluoride reduction and water recycle are projected to be 17.7 cents per 1,000 gallons.

Appendix (A)

RELATED REFERENCES

Douglas W. Thompson, etal

TREATMENT AND DISPOSAL OF REGENERATION WASTEWATER FROM  
ACTIVATED ALUMINA COLUMNS USED FOR FLUORIDE REMOVAL  
FROM GROUNDWATER AT ROCKY MOUNTAIN ARSENAL

January, 1980

Rubel and Hager, Inc.

FINAL REPORT ON PILOT TEST PROGRAM FOR REMOVAL OF EXCESS  
FLUORIDE FROM ACTIVATED CARBON EFFLUENT

November 30, 1979

Rubel and Hager, Inc.

LABORATORY REPORT - REMOVAL OF FLUORIDE FROM CONCENTRATED  
FLUORIDE WASTES

October 31, 1979

Rubel and Hager, Inc.

THE REMOVAL OF FLUORIDE FROM CONCENTRATED FLUORIDE WASTEWATER  
A LITERATURE SEARCH

June 29, 1979

Rubel and Hager, Inc.

TEST PLAN FOR PILOT TEST PROGRAM FOR REMOVAL OF EXCESS FLUORIDE  
FROM ACTIVATED CARBON EFFLUENT

April 6, 1979

TEST APPARATUS

The test apparatus is a fully assembled skid-mounted treatment system (see Figure 1 for Schematic Flow Diagram). The system is designed to treat the activated carbon effluent at the rate of 5 gpm at 50 psig maximum working pressure. There are two treatment vessels (fourteen-inch diameter by ninety six inches high) each contains 3.75 cubic feet of Alcoa (grade F-1, - 28+48 mesh) activated alumina. This manually operated system is piped to permit one treatment unit to perform design flow treatment individually, or two units can be operated in either series or parallel. The system contains 1" PVC schedule 80 threaded pipe and fittings with manually operated full port ball valves. Accessories for each treatment unit include pH sensors with panel mounted indicators at inlet and outlet, sample points at inlet and outlet, a pressure gauge, an air vent, a flow totalizer, injection points for acid and caustic, and an in-line static chemical mixer.

The system also includes a feed water pump, a caustic feed system, an acid feed system, a zeolite softener, and sample points. The caustic feed system includes one twelve gallon solution tank and one metering pump for 50% sodium hydroxide. The caustic is employed during regeneration only; therefore, one pump serves both treatment units. The acid feed system includes one fifty gallon solution tank and two metering pumps for dilute sulfuric acid. One acid pump is required for pH adjustment for each treatment unit. The zeolite softener is an optional feature which can be used to pretreat raw water during caustic regeneration. There are also provisions for adding other pretreatment equipment, or additional treatment units.

The entire treatment system is mounted on a steel skid (six feet wide by ten feet long) which is elevated approximately eighteen inches above the floor. The skid is located adjacent to the activated carbon system in the north boundary treatment building. Raw water is piped from the carbon adsorbers to the feed water pump suction. The treated water is piped to a designated discharge point. Regeneration wastewater is collected in 50 gallon drums for analysis and waste treatment process development.

TEST PROGRAM

The scope of the test program for the 5 gpm pilot included six complete treatment cycles. Each cycle consisted of a treatment run through exhaustion of the treatment bed followed by a chemical regeneration.

Treatment Unit No. 1 was designated as the primary treatment unit; Treatment Unit No. 2 was designated as the standby treatment unit. All testing took place in the primary unit.

Upon completion of the installation of the pilot plant test

apparatus, initial start-up procedures began. This entailed placing the treatment media in the vessels and properly back-flushing. Concurrently all instruments were calibrated and mechanical equipment checked out. The EPA Technical Report, "Removal of Excess Fluoride from Drinking Water" by Rubel and Woosley<sup>2</sup> elaborates upon start-up and operating procedures which apply to this type of treatment plant.

During all treatment runs, operating personnel conducted pilot plant surveillance and operating functions which included the following:

1. Monitor raw water flow rate, maintain at 5 gpm  $\pm$  1/4 gpm (unless directed otherwise)
2. Monitor raw water pH, maintain at 5.3-5.5 (unless directed otherwise)
3. Sample raw and treated water for analysis at six hour intervals. Record pH and fluoride levels at time of sampling. Collect samples for laboratory analysis.
4. Maintain record at pilot plant of flow rate, total flow, pH and fluoride levels.
5. Maintain supply of dilute acid in solution tank. Record all concentrated acid additions.

Treatment runs were continuous until terminated upon saturation of the treatment bed. Saturation was defined as the point at which the average fluoride level in the treated water exceeded 1.20 mg/l (optimum level for this climate.) In any operational fluoride removal plant equipped with two or more treatment units and/or treated water storage facilities, blending is achieved resulting in constant distribution of optimum levels of fluoride.

The Regeneration Mode included backwash at 7-1/2 gpm for ten to twenty minutes. The bed was then drained, followed by an upflow regeneration with 100 gallons of 1% sodium hydroxide using softened raw water to dilute 50% sodium hydroxide at a flow rate of 2.5 gpm for forty minutes. This was followed by an upflow soft water rinse of 5 gpm for 120 minutes followed by another draining of the liquid level down to the top of the bed. Finally, a downflow regeneration identical to the upflow described above was accomplished. This was followed by downflow neutralization using soft raw water adjusted to pH 2.5 for 120 minutes. At this point raw water was switched over to unsoftened for the duration of the neutralization and treatment run. When the pH of the treated effluent dropped to 7.5, the pH of the raw water was adjusted to 3.5. When the pH of the treated effluent reached 6.5, the pH of the raw water was adjusted to 5.5 where it remained for the duration of the run.

Appendix B (3)

Wastewater from the regeneration and neutralization was collected in 50 gallon batches for study of ultimate disposal methods. The regeneration described above was not modified during the six test runs.

## Appendix C (1)

TABULATED DATA TREATMENT RUN NO. 7

DATE	TIME	METER READING	TOTAL FLOW	RAW WATER		TREATED WATER		
				pH	F (mg/l)	pH	F (mg/l)	TOTAL GRAINS
8/27/79	1320	153020	-	2.5	3.7	12.0	2.7	--
	1400	153240	170	2.5		11.1	1.1	18
	1430	153400	330			9.4	0.3	46
	1500	153540	470			8.9	0.2	74
	1530	153670	600			8.65	0.15	101
	1600	153810	740			8.3	0.11	130
	1800	154390	1320		3.7	6.9	0.06	252
	2200	155530	2460			6.7	0.04	499
8/28/79	0600	157810	4740			7.0	0.21	979
	1000	158950	5880		3.7	7.1	0.31	1212
	1400	160070	7000			7.2	0.65	1426
	1800	161210	8140			7.3	1.0	1626
	2200	162340	9270		3.9	7.3	1.5	1798
8/29/79	0600	164600	11530			7.3	2.3	2049
	1000	165700	12630			7.3	2.4	2145
	1400	166840	13770			7.4	2.65	2232
	1800	138140	14930			7.3	2.8	2300
	2000	168580	15510		3.8	7.4	2.9	2330

## Appendix C (2)

## TABULATED DATA TREATMENT RUN NO. 8

DATE	TIME	METER READING	TOTAL FLOW	RAW WATER		TREATED WATER			
				pH	F (mg/l)	pH	F (mg/l)	TOTAL GRAIN	
12/11/79	1545	169370	-	2.5	4.0	13.0	1.4	-	
	1615	169490	120	2.5	4.0	12.5	0.8	20	
	1645	169600	230	2.5	4.0	11.8	0.3	43	
	1715	169720	350	2.5	4.0	10.4	0.06	71	
	1745	169810	470	2.5	4.0	9.9	0.04	99	
	1815	169950	580	2.5	4.0	9.8	0.04	124	
	1845	170050	680	2.5		9.5	0.03	147	
	1915	170160	790	2.5	4.0	9.2	0.03	172	
	1945	170270	900	2.5		8.7	0.03	197	
	2015	170380	1010	2.5		8.3	0.02	222	
	2030			3.5		7.5	0.02		
	2045	170490	1120	4.5		6.6	0.02	247	
	12/12/79	0100	171620	2250	5.5	4.0	5.7	0.1	276
		0715			5.5	4.3	5.3	0.1	
0930		174160	4790	5.5	4.3	5.3	0.1	900	
1100		174550	5180	4.5	4.1	5.0	0.04	992	
1510		176150	6780	5.5	4.1	5.1	0.15	1361	
12/13/79	2400			6.0	3.7	5.9	0.01		
	0715	180780	11410	5.6	3.6	5.9	0.03	2326	
	1300	182420	13050	5.7	3.6	5.9	0.06	2665	
	1930	184390	15020	5.1	3.7	5.6	0.45	3030	
12/14/79	0100			5.5	3.7	5.6	0.62		
	0700	187790	18420	5.6	3.8	5.7	0.71	3653	
	1300			5.1	3.7	5.6	0.98		
	1600	190240	20870						
	1930	191480	22110	4.9	3.5	5.6	1.5	4069	
	1000			5.3	3.5	5.3	1.6	4418	
	0700	194380	25010	5.2	3.5	5.5	1.4		
12/15/79	1300			4.8	3.5	5.4	1.3		
	1900			4.9	3.5	5.3	1.6		
12/16/79	0100			5.3	3.5	5.5	1.5		
	0700	201590	32220	5.3	3.5	5.4	1.4	5265	
	1300			4.9	3.5	5.4	1.4		
12/17/79	1900	205030	35660	5.10	3.5	5.4	1.5	5661	
	0100			5.4	3.5	5.5	1.6		
	0700			5.5		5.7	1.7	6079	
	0925	209140	39770						
	1300			4.9	3.4	5.6	1.9		
	1420	210540	41170						
	1910	211910	42540	5.0	3.4	5.3	2.1	6293	

Appendix C (3)  
TABULATED DATA TREATMENT RUN NO. 9

DATE	TIME	METER READING	TOTAL FLOW	RAW WATER		TREATED WATER		
				pH	F (mg/l)	pH	F (mg/l)	TOTAL GRAINS
1/8/80	1730	225720		2.4		9.5	0.45	
	1800	225860	140			8.8	0.21	
	1830	226020	300	4.0		7.2	0.07	
	1845			4.8		6.7		
	1900	226170	450	5.0	3.3	6.5	0.04	87
1/9/80	0100			5.5	3.3	5.1	0.06	
	0700	229830	4110	5.5	3.4	5.4	0.05	806
	1300			5.3	3.4	5.5	0.05	
1/10/80	1900	233380	7660	5.4		5.4	0.02	1530
	0100			5.5	3.5	5.5	0.05	
	0700	237030	11310	5.4	3.6	5.5	0.08	2283
1/11/80	1300			5.1		5.3	0.10	
	1900	240550	14830	5.2	3.5	5.3	0.19	2973
	0100			5.2	3.5	5.3	0.32	
1/12/80	0700	244210	18490	5.4	3.5	5.3	0.45	3636
	1900	247740	22020	5.4	3.5	5.4	0.78	4210
	0100			5.3	3.5	5.4	0.64	
1/13/80	0700			5.3	3.4	5.4	0.91	
	1900	254910	29190	5.3	3.5	5.3	1.0	5254
	0100			5.2	3.6	5.3	2.3	
1/14/80	0700	258610	32890	5.3	3.7	5.4	2.3	5552
	1300			5.3	3.7	5.3	2.1	
	1800	262150	36430	5.3	3.6	5.3	2.3	5827
1/15/80	0100			5.2	3.6	5.3	2.1	
	0700	265750	40030	5.3	3.6	5.4	2.2	6134
	1300			5.3	3.6	5.4	2.5	
1/15/80	1900	269340	43620	5.3	3.5	5.3	2.5	6344
	0100			5.2	3.6	5.2	2.5	
	0700	272930	47210	5.2	3.6	5.3	2.5	6568

## Appendix C (4)

## TABULATED DATA TREATMENT RUN NO. 10

DATE	TIME	METER READING	TOTAL FLOW	RAW WATER		TREATED WATER		
				pH	F (mg/l)	pH	F (mg/l)	TOTAL GRAINS
2/14/80	1640	288750		2.5		12.1	6.8	
	1800	289330	380	2.5	3.5	9.5	0.7	62
	1830	289490	540	2.5	3.6	8.7	0.3	93
	1900	289650	700	2.5	3.6	7.9	0.1	125
	1930	289800	850	3.5	3.5	7.2	0.07	155
	2000	289940	990	4.5	3.5	6.6	0.02	183
	2400							
2/15/80	0830	293760	4810	5.5	3.6	5.3	0.02	983
	1300	295100	6150	5.2	3.6	5.3	0.01	1264
	1900	296950	8000	5.2	3.5	5.3	0.00	1642
2/16/80	1300	298800	9850	5.4	3.5	5.4	0.03	2017
	1900	300650	11700	5.5	3.6	5.5	0.08	2398
	1000	302525	13585	5.5	3.6	5.6	0.17	2776
	0700	304420	15470	5.6	3.6	5.6	0.34	3135
2/17/80	1300	306300	17350	5.5	3.6			
	1900	308180	19230	5.5	3.7	5.6	0.95	3739
	0100	310045	21095	5.5	3.7	5.5	1.2	4012
	0700	311910	22960	5.5	3.7	5.5	1.2	4284
2/18/80	1200	313775	24825	5.5	3.7	5.5	1.6	4517
	1900	315640	26690	5.5	3.7	5.6	1.9	4713
	0100	317515	28565	5.5	3.7	5.6	2.0	4899
	1900	319390	30440	5.5	3.6	5.6	2.1	5063
2/19/80	1300	321275	32325	5.4	3.8	5.5	2.1	5250
	1900	323160	34210	5.4	3.8	5.5	2.4	5404
	0100	335110	36060	5.5	3.6	5.6	2.4	5541
	1800	326580	37630	5.3	3.6	3.5	2.6	5627
2/20/80	1300	330650	41700	5.4	3.6	5.4	2.4	5898

## Appendix C (5)

TABULATED DATA TREATMENT RUN NO 11

DATE	TIME	METER READING	TOTAL FLOW	RAW WATER		TREATED WATER		
				pH	F (mg/l)	pH	F (mg/l)	TOTAL GRAINS
2/27/80	1725	333730		2.5		11.6	4.9	
	1845	334120	390	2.5	3.7	9.8	1.15	58
	1930	334360	630	2.5	3.7	8.5	0.17	107
	2015	334560	830	3.5	3.7	7.0	0.05	149
	2030	334630	900	4.5		6.6	0.03	164
2/29/80	0900	338110	4380	5.0	3.6	5.2	0.05	901
	1300	339230	5500	4.9	3.7	5.3	0.01	1143
	1930	341030	7300	5.4	3.6	5.5	0.04	1523
3/1/80	0100			5.3	3.6	5.5	0.06	
	0700							
	1300	345820	12090	5.1	3.6	5.6	0.08	2509
	1900	347690	13960	5.7	3.6	5.8	0.15	2886
3/2/80	0100			5.6	3.6	5.4	0.34	
	0800	351940	18209	5.6	3.6	5.7	0.67	3631
	1300			5.6	3.6	5.8	0.75	
3/3/80	1900	355340	21610	5.8	3.7	5.8	0.96	4176
	0100			5.7	3.5	5.5	1.1	
	0700	359160	25430	5.7	3.6	5.7	1.4	4667
	1300	361090	27360	5.8	3.7	5.9	1.9	4870
3/4/80	1800	362630	28900	5.2	3.6	5.6	2.3	4987
	0700	366550	32820	5.3	3.7	5.3	1.9	5386
	1300	368390	34660	5.3	3.7	5.5	2.3	5536
3/5/80	1800	369900	36170	5.2	3.7	5.4	2.3	5659
	0100			5.3	5.7	5.5	2.2	
	0730	374010	40280	5.4	3.7	5.5	2.4	5971
	1300	375660	41930	5.3	3.7	5.5	2.6	6077

## Appendix C (6)

TABULATED DATA TREATMENT RUN NO. 12

DATE	TIME	METER READING	TOTAL FLOW	RAW WATER		TREATED WATER		TOTAL GRAINS
				pH	F (mg/l)	pH	F (mg/l)	
3/26/80	0400	377075		2.5	3.8	11.1	1.8	
	0500	377347	272	2.5		9.3	0.7	49
	0515	377420	345	2.5		8.8	0.5	63
	0600	377630	555	3.5	3.8	7.4	0.12	108
	0630	377777	702	4.5	3.6	6.5	0.06	253
	0700	381580	4505	5.6	3.6	5.7	0.0	1053
	0950							
	1100	382710	5635	5.7	3.7	5.8	0.0	1297
	1900			5.5	3.7	5.7	0.0	
	3/28/80	0900	389290	12215	5.6	3.6	5.6	0.18
1300				5.5	3.6	5.7	0.29	
1730		391820	14745	5.5	3.6	5.6	0.45	3083
3/29/80	0100			5.6	3.6	5.7	0.8	
	1100	397050	19975	5.5	3.6	5.7	0.97	3909
	1930			5.6	3.6	5.6	1.2	
	2100	400040	22965					
3/30/80	0100			5.6	3.6	5.8	1.8	
	1230	404680	27605	5.6	3.6	5.6	1.7	4748
3/31/80	0100			5.6	3.5	5.7	1.9	
	0830	410650	33575	5.6	3.6	5.7	2.1	5261
	1300	411990	34915	5.5	3.6	5.5	2.4	5352
	1730	413350	36275	5.8	3.7	5.6	2.5	5446
	0100	452035	38685	5.7	3.8	5.8	2.5	5601

## Appendix C (7)

TABULATED DATA TREATMENT RUN NO 13

DATE	TIME	METER READING	TOTAL FLOW	RAW WATER			TREATED WATER	
				pH	F (mg/l)	pH	F (mg/l)	TOTAL GRAINS
4/21/80	1545	420660						
	1600	420730	70					
	1615	420810	150	3.8	3.3	11.7	4.6	
	1645	420970	310	3.0	3.4	11.2	1.5	17
	1745	421270	610	3.0	3.3	9.6	.40	67
	1830	421490	830	3.1	3.4	9.0	.27	108
	1930	421780	1120	2.5		8.4	.18	164
	2000	421930	1270	3.2		7.5		
	2030	422080	1420	4.5	3.4	6.7	.08	219
	4/22/80	0300	424030	3370	5.3	3.6	5.3	.02
0900		425800	5140	5.2	3.6	5.4	.03	1012
1300		427000	6340	5.2	3.6	5.4	.04	1262
1730		428300	7640	5.3	3.5	5.4	.03	1528
4/23/80	0100	430550	9890	5.4	3.6	5.5	.11	1990
	0800	432580	11920	5.3	3.6	5.5	.19	2396
	1300	434050	13390	5.3	3.7	5.5	.33	2686
	1730	435360	14700	5.0	3.7	5.2	.59	2919
4/24/80	0100	437610	16950	5.2	3.6	5.3	.85	3281
	0800	439550	18890	5.2	3.6	5.3	1.0	3575
	1300	441000	20340	5.2	3.5	5.3	1.1	3783
	1730	442290	21630	5.2	3.6	5.3	1.3	3951
4/25/80	0100	444540	23880	5.5	3.6	5.5	1.5	4236
	0800	446450	25790	5.4	3.5	5.5	1.6	4454
	1300	447870	27210	4.9	3.6	5.5	1.9	4595
	1900	449680	29020	5.4	3.6	5.5	1.9	4779
4/26/80	0100	451480	30820	5.5	3.5	5.6	2.2	4919
	0800	453400	32740	5.5	3.5	5.6	2.2	5069
	1300	454900	34240	5.5	3.6	5.6	2.1	5201
	1700	456000	35340	5.5	3.6	5.5	2.3	5287
4/27/80	0100	458400	37740	5.5	3.6	5.5	2.3	5468
	0930	460780	40120	5.4	3.7	5.5	2.6	5626
	1300	461830	41170	5.5	3.7	5.5	2.6	5694
	1900	463530	42870	5.5	3.7	5.5	2.8	5787

## Appendix C (8)

## TABULATED DATA TREATMENT RUN NO. 14

DATE	TIME	METER READING	TOTAL FLOW	RAW WATER		TREATED WATER		
				pH	F (mg/l)	pH	F (mg/l)	TOTAL GRAINS
5/16/80	1032	464670						
	2250	464750	80	2.4	3.6	11.3	3.5	
5/17/80	0120	465200	530	2.5		9.2	0.42	83
	0230	465270	600	2.4	3.5	8.8	0.23	96
	0100	465400	730	3.3	3.4	8.6	0.18	120
	0200			4.5		7.5		
	0700	467250	2580	4.9	3.4	4.9	0.09	489
	1300			4.9	3.7	5.1	0.04	
	1830	470790	6120	5.2	3.6	5.1	0.06	1232
5/18/80	0100			4.9	3.7	5.2	0.12	
	0800	474810	10140	5.0	3.9	5.1	0.38	2064
	1800	477980	13310	4.9	3.7	5.0	0.68	2624
5/19/80	0100			5.1	3.9	4.8	0.89	
	0700	482000	17330	4.9	3.7	5.1	1.0	3263
	1300	483800	19130	5.0	3.7	5.2	1.2	3532
	1730	485170	20500	5.2	3.8	5.3	1.4	3726
5/20/80	0100			5.1	3.6	5.2	1.4	
	0700	489390	24720	5.4	3.7	5.3	1.5	4249
	1315	491140	26470	5.4	3.7	5.4	1.9	4434
	1730	492520	27850	5.3	3.6	5.4	1.9	4577
5/21/80	0100	494770	30100	5.3	3.4	5.4	2.2	4756
	0830	497120	32450	5.3	3.5	5.4	2.3	4932
	1300	498500	33830	5.3	3.7	5.5	2.5	5700
	1730	499870	35200	5.3	3.7	5.4	2.6	5789
5/22/80	0100			5.3	3.5	5.4	2.6	
	0710	504070	39400	5.2	3.5	5.6	2.7	6042
	1300	505890	41200	5.3	3.6	5.5	2.9	6118
	1730	507240	42510	5.2	3.6	5.4	2.9	6177
5/23/80	0100	551860	44620	5.3	3.5	5.4	3.0	6277

Appendix D (1)

REGENERATION #7

GRAINS RECOVERY

Regeneration data not recorded.

REGENERATION #8

GRAINS RECOVERY

Tank composite 806 gallons ph 11.9 fluoride 91 mg/l

Grains Recovered 4219

Appendix D (2)

REGENERATION #9

GRAINS RECOVERY

<u>50 GALLON DRUM NUMBER</u>	<u>pH</u>	<u>FLUORIDE mg/l</u>	<u>GRAINS RECOVERED</u>
1	9.85	206	567
2	12.4	418	1246
3	12.1	295	850
4	11.8	120	287
5	11.6	73	
6	10.6	47	
7	9.8	42	124
8	11.7	242	777
9	11.9	133	427
10	11.8	73	214
11	11.6	20	63
12	11.4	9	<u>28</u>
		TOTAL GRAINS	4935
600		132 (ave)	

Appendix D (3)

REGENERATION #10

GRAINS RECOVERY

<u>50 GALLON DRUM NUMBER</u>	<u>pH</u>	<u>FLUORIDE mg/l</u>	<u>GRAINS RECOVERED</u>
1	9.8	206	662
2	11.6	786	2528
3	11.6	334	1074
4	11.4	130	418
5	11.2	92	296
6	11.1	145	466
7	10.7	75	241
8	11.8	269	865
9	11.9	122	392
10	11.7	25	80
11	11.6	9	<u>29</u>
		<u>TOTAL GRAINS</u>	<u>7051</u>
550		218 (ave)	

Appendix D (4)

REGENERATION #11

GRAINS RECOVERY

<u>50 GALLON DRUM NUMBER</u>	<u>pH</u>	<u>FLUORIDE mg/l</u>	<u>GRAINS RECOVERED</u>
1	7.8	68	219
2	11.4	773	2486
3	11.7	270	868
4	11.4	115	370
5	10.8	77	247
6	11.8	340	1093
7	12.2	216	695
8	12.2	30	96
9	11.9	8	<u>27</u>
			TOTAL GRAINS 6101
450		230 (ave)	

Appendix D (5)

REGENERATION #12

GRAINS RECOVERY

50 GALLON DRUM NUMBER	pH	FLUORIDE mg/l	GRAINS RECOVERED
1	9.4	168	540
2	11.8	690	2219
3	11.6	497	1598
4	11.3	240	772
5	11.2	100	322
6	11.1	52	168
7	10.9	31	102
8	10.8	18	58
9	10.2	13	43
10	11.8	155	498
11 ½ barrel	12.2	136	<u>219</u>
		TOTAL GRAINS	6539
575		193 (ave)	

Appendix D (6)

REGENERATION #13

GRAINS RECOVERY

50 GALLON DRUM NUMBER	pH	FLUORIDE mg/l	GRAINS RECOVERED
4	6.97	47	115
5	9.85	714	1753
6	11.75	1040	2554
7	11.92	516	1267
8	11.70	238	584
9	11.45	154	378
10	11.21	114	280
11	10.79	83	205
12	10.75	66	163
13	10.73	48	141
14	10.64	31	92
15	10.42	24	71
16	12.13	177	517
17	12.18	46	136
18	12.00	9	27
19 ½ barrel	11.52	10	<u>15</u>
		TOTAL GRAINS	8289
975		144 (ave)	