

81267R01

original

Rocky Mountain Arsenal
Information Center
Commerce City, Colorado

INVESTIGATION OF THE NORTHWEST AREA OF
ROCKY MOUNTAIN ARSENAL

GEOHYDROLOGY DIVISION
CONTAMINATION CONTROL DIRECTORATE

NOV 78

19950125 135

REPORT DOCUMENTATION PAGE

Form Approved
OMB No. 0704-0188

Public reporting burden for this collection of information is estimated to average 1 hour per response, including the time for reviewing instructions, searching existing data sources, gathering and maintaining the data needed, and completing and reviewing the collection of information. Send comments regarding this burden estimate or any other aspect of this collection of information, including suggestions for reducing this burden, to Washington Headquarters Services, Directorate for Information Operations and Reports, 1215 Jefferson Davis Highway, Suite 1204, Arlington, VA 22202-4302, and to the Office of Management and Budget, Paperwork Reduction Project (0704-0188), Washington, DC 20503.

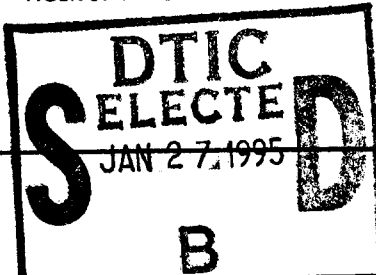
1. AGENCY USE ONLY (Leave blank)		2. REPORT DATE 11/00/78	3. REPORT TYPE AND DATES COVERED	
4. TITLE AND SUBTITLE INVESTIGATION OF THE NORTHWEST AREA OF ROCKY MOUNTAIN ARSENAL			5. FUNDING NUMBERS	
6. AUTHOR(S)				
7. PERFORMING ORGANIZATION NAME(S) AND ADDRESS(ES) ROCKY MOUNTAIN ARSENAL (CO.) COMMERCE CITY, CO			8. PERFORMING ORGANIZATION REPORT NUMBER 81267R01	
9. SPONSORING / MONITORING AGENCY NAME(S) AND ADDRESS(ES)			10. SPONSORING / MONITORING AGENCY REPORT NUMBER	
11. SUPPLEMENTARY NOTES				
12a. DISTRIBUTION / AVAILABILITY STATEMENT APPROVED FOR PUBLIC RELEASE; DISTRIBUTION IS UNLIMITED			12. DISTRIBUTION CODE	
13. ABSTRACT (Maximum 200 words) THE GOAL OF THE RMA NORTHWEST AREA EFFORT WAS TO EVALUATE GROUND WATER POLLUTION OF THE NEAR SURFACE AQUIFER IN THIS AREA OF THE ARSENAL. TO ACCOMPLISH THIS GOAL, SUFFICIENT ADDITIONAL GEOLOGICAL, HYDROLOGICAL AND WATER CHEMISTRY DATA WAS COLLECTED TO INTERPRET EXISTING INFORMATION AND PROVIDE DATA FROM PARTS OF THE STUDY AREA WHERE LITTLE OR NO DATA PREVIOUSLY EXISTED. SOIL SAMPLES WERE COLLECTED TO PROVIDE GEOLOGICAL AND HYDROLOGICAL INFORMATION. WELL WATER SAMPLES WERE DRAWN TO DETERMINE GROUND WATER CHEMISTRY. THE MOST SIGNIFICANT WATER CONSTITUENTS WERE DIMP DCPD, DBCP (NEMAGON) AND FLUORIDE. FLUORIDE LEVELS EXCEEDING THE ACCEPTABLE STANDARD APPEARED TO BE CROSSING THE NORTHWEST ARSENAL BOUNDARY. HIGH DIMP CONCENTRATIONS WERE OBSERVED IN AN AREA GENERALLY NORTHWEST OF THE NORTHWEST PART OF BASIN F. THE EXISTENCE OF DCPD COULD NOT BE ESTABLISHED BECAUSE OF PROBLEMS WITH SAMPLING. DBCP WAS OBSERVED AT VERY LOW CONCENTRATIONS AT WIDELY <div style="text-align: right; margin-right: 100px;">DTIC QUALITY INSPECTED 3</div>				
14. SUBJECT TERMS SOIL, GROUNDWATER, CHEMICALS, TOPOGRAPHY, DBCP, DIMP, DCPD, CONTAMINATION			15. NUMBER OF PAGES	
17. SECURITY CLASSIFICATION OF REPORT UNCLASSIFIED			16. PRICE CODE	
18. SECURITY CLASSIFICATION OF THIS PAGE	19. SECURITY CLASSIFICATION OF ABSTRACT	20. LIMITATION OF ABSTRACT		

ABSTRACT

1. The goal of the Rocky Mountain Arsenal (RMA) northwest area effort was to evaluate groundwater pollution of the near surface aquifer in this area of the Arsenal. To accomplish this goal, sufficient additional geological, hydrological, and water chemistry data was collected to interpret existing information and provide data from parts of the study area where little or no data previously existed.

2. Soil samples were collected to provide geological and hydrological information. Well water samples were drawn to determine groundwater chemistry. The most significant water constituents were DIMP, DCPD, DBCP (Nemagon), and Fluoride.

3. Similar geological and hydrological results were obtained as previously mentioned. Fluoride levels exceeding the acceptable standard appeared to be crossing the northwest Arsenal boundary. High DIMP concentrations were observed in an area generally northwest of the northwest part of Basin F. The existence of DCPD could not be established because of problems with sampling. DBCP was observed at very low concentrations at widely dispersed on-post sites. These results must be reviewed later as on-going work is completed in neighboring areas which impact upon the area of RMA. In particular, possible contamination of a deep aquifer may require investigation.

Accession For	
NTIS GRA&I	<input checked="" type="checkbox"/>
DTIC TAB	<input type="checkbox"/>
Unannounced	<input type="checkbox"/>
Justification	
By _____	
Distribution _____	
Availability Codes	
Dist	Avail and/or Special
A-1	

INVESTIGATION OF THE NORTHWEST AREA OF RMA

1. Introduction

a. Authorization - The detection of pollution in surface and subsurface waters off-post north of the Rocky Mountain Arsenal (RMA) caused the State of Colorado Department of Health to issue three Cease and Desist Orders against Shell Chemical Company (SCC) and RMA in Apr 75. These Orders stated that:

- (1) SCC and RMA immediately stop the off-post discharge (both surface and subsurface) of contaminants.
- (2) Take action to preclude future off-post discharge of contaminants.
- (3) Provide written notice of compliance with item (1).
- (4) Submit a proposed plan to meet the requirements of item (2).
- (5) Develop and institute a surveillance plan to verify compliance with items (1) and (2).

b. As a result of these orders, a program was developed and implemented by RMA to satisfy the compliance criteria. The Contamination Migration Division, Geohydrology Branch, was established as part of this program.

2. Purpose - The purpose of the Contamination Migration Division, Geohydrology Branch, was to:

- a. Undertake an investigation to enable a detailed understanding of the geology and hydrology of RMA.
- b. Utilize the geologic and hydrologic data to determine the contaminant transport mechanism as it relates to off-post contamination.
- c. Utilize all data relationships to identify the contamination sources.
- d. Establish a surveillance plan so that monitoring during and after the investigation can be accomplished. As part of the overall Contamination Control Program for RMA, the northwest area study was initiated.

3. Background

a. RMA History

(1) RMA was established in 1942 by the US Army to produce chemical warfare agents and incendiary munitions. The Arsenal is located immediately northwest of the City of Denver and seven miles south of the City of Brighton in Colorado.

INVESTIGATION OF THE NORTHWEST AREA OF RMA - Cont

(2) Since 1946, part of the Arsenal facilities were leased to private industry for chemical manufacturing. At the present time, they are leased to the SCC and are being used to manufacture pesticides.

(3) Production of chemical warfare agents by the US Government continued at the Arsenal until 1957. They were stored in various munitions and bulk containers.

(4) In 1968, the US Army Materiel Command made a decision to reduce stocks of obsolete chemical agents and munitions stored at RMA. In 1971, demilitarization was initiated utilizing the production facilities at the Arsenal. The demilitarization program has continued to the present time, with the major portions completed by 1977.

b. Chronology of Contamination

(1) During the production years (1942 to 1956), the industrial wastes generated at RMA by private leasee and Government operations were disposed of in unlined ponds. Basin A, located in Section 36 (Figure 1), was the most extensively used unlined pond. At the peak of production in 1955, the surface water area in the Basin reached approximately 300 acres in size. The use of the natural Basin with no provisions for waste containment allowed large quantities of contamination to percolate into the groundwater system.

(2) In 1951, the first indication of off-post pollution was evidenced in irrigation water being used on a farm northwest of RMA. In 1954, the pollution problems in irrigation water had increased. The water quality was deteriorating and the area influenced was increasing. In that same year, some crop damage was alleged from the use of polluted water for irrigation. Due to the increase in complaints from local farmers, the US Army initiated actions to investigate the groundwater contamination problem.

(3) As a result of the investigations, Reservoir F (Figure 1) was constructed. Since 1956, industrial wastes have been pumped to this Reservoir.

(4) Monitoring of groundwater from selected wells on and off post continued after 1956. In 1974, contaminants that originated from RMA operations were detected in surface waters located at the north boundary of RMA and also in wells located near the City of Brighton. As a result, the Cease and Desist Orders were issued by the Colorado Department of Health.

INVESTIGATION OF THE NORTHWEST AREA OF RMA - Cont

4. Investigative Procedures - Several studies of the contaminated groundwater problems and the geologic and hydrologic settings have been conducted since 1956. Petri and Smith (1956) studied pollution of groundwater near the Arsenal in 1955-56. The study indicated large concentrations of contaminated water existed from Basin A northwest to the South Platte River. The US Army Corps of Engineers, Omaha District (1961) conducted an investigation of the geologic and hydrologic conditions relating to the contamination problems for the Arsenal and adjoining property. In 1975, the US Geological Survey (USGS) conducted a study of the geologic and hydrologic conditions at the RMA, Konikow (1975). In 1976, the USGS developed a computer modeling program which was used to simulate groundwater movement and contaminant transport. Additional model studies were completed by Robson (1977) of the USGS using DIMP as the tracer contaminant rather than chlorides, as used in the Konikow model.

a. Several interim reports have been published on the geology, hydrology, and groundwater contamination in the study area as part of the northwest area investigation.

b. Final reports from the previous investigations have provided a variety of maps on bedrock contour, water level contour, contamination distribution, saturated thickness, and transmissivity.

c. Evaluation of these reports indicate that there are two major sources of contamination: Basins A and F. The studies also indicate that the northwest area is contaminated and pollutants are migrating off post in the groundwater system.

5. Present Investigations

a. Introduction

(1) The objective of this investigation was to: (a) Collect enough data from the study area so that existing reports and data could be adequately interpreted, and (2) Collect data from areas where little or no data previously existed. This investigation of the northwest area (Figure 1) incorporated the findings from all the previous studies, with a program of additional investigative effort.

(2) The exploratory borings were to be utilized to identify the bedrock erosional surface and gather subsurface data on the groundwater aquifer. Monitoring wells were to be installed which would permit monitoring of the groundwater quantity and quality.

INVESTIGATION OF THE NORTHWEST AREA OF RMA - Cont

(3) The investigation in the report area was started in 1976 and continued into 1978. Figure 2 shows the locations of the monitoring wells used to evaluate water quality. Figure 3 shows the locations of borings that were used to determine the geologic setting.

b. Procedures

(1) The field investigation included drilling borings using an auger drilling technique. Soil samples were collected during the drilling operation, and a field boring log was maintained for each site. The soil samples were returned to the laboratory, where a visual check of the samples and the boring log was conducted. Selected soil samples were submitted to the Geophysical Analysis Laboratory (GAL) for physical properties testing (e.g., grain size, Atterberg limits). Results of these tests were used to verify field interpretation of the physical characteristics of the subsurface soils, especially the aquifer materials.

(2) After drilling and sampling of each site was completed, a decision was made about installing a monitoring well. This decision was based upon the subsurface conditions encountered at that site. Monitoring wells were cased with a 2" I.D. PVC plastic pipe. A four foot perforated section with .020 inch slot openings was positioned at the bottom of each well in the saturated portion of the aquifer.

(3) Water samples (see Table 1 and Figure 2) to evaluate aquifer condition were collected and analyzed by MALD following the previously used and approved procedures. Wells were sampled at least once. Those wells which are part of the 360° monitoring program had been sampled many times over an extended time. A variety of constituents were investigated. In many cases, only a portion of these constituents were investigated in a particular sample. The following parameters were investigated: DIMP (diisopropylmethyl phosphonate), DCPD (dicyclopentadiene), DBCP (dibromochloropropane, Nemagon), Sodium, Chloride, Sulfate, Nitrate, Fluoride, Oxathiane, Dithiane, Parachlorophenyl methyl sulfide, Chlorophenyl methyl sulfoxide and sulfone, Aldrin, Dieldrin, Isodrin, DDE, DDT, and Endrin.

6. Results

a. Geology

(1) The report area is situated within the Colorado piedmont section of the Denver Basin. The Arsenal lies on the eastern edge of a broad valley of the South Platte River, east of the foothills of the front range of the Rocky Mountains.

INVESTIGATION OF THE NORTHWEST AREA OF RMA - Cont

(2) In the late Cretaceous and early Tertiary time, major deposition of sediments occurred in the Denver Basin. In time, a widespread uplift occurred causing erosion which removed most of the Tertiary sediments and exposed the late Cretaceous sediments. The remnants of this erosional period were pediments, gravel-capped hills, which were formed along the eastern plains near the foothills. With the retreat of the glaciers in Quaternary time, massive erosion of the Cretaceous formation continued. This erosion shaped the surface of the Denver-Arapahoe formation, which serves as the bedrock unit for the RMA Region. The Denver-Arapahoe formation is the first recognizable geologic unit, which is encountered beneath the alluvium overburden.

(3) The Denver-Arapahoe formation consists of varying mixtures of sand, silt, and clay that are generally impervious. The unit was heavily consolidated by the sediments of the tertiary formations which were eroded away. The consolidation characteristics of the formation provide the basic key for the identification of the bedrock surface.

(4) The formation outcrops at three gravel-capped pediments on the Arsenal. These outcrops are located west and north of Basin A and are characterized by the prominent topographic highs (Figure 4).

(5) Although this geologic unit is considered impervious, the formation is known to contain permeable zones (McConaghy 1964). Generally, these zones are less permeable than the alluvium overburden. Nonetheless, large saturated zones of 30 to 40 feet in thickness have a great potential for transporting contaminated groundwater. Such large saturated zones have been encountered in investigations done between the northwest area and Basin A, and analysis of water taken from these zones indicates that the water is contaminated.

(6) The subsurface conditions in the study area consist of alluvial sands and gravels interbedded with clay and silt lenses. The sands and gravels are overlaid with fine grained mixtures of clayey silts, silty clays, sandy clays, and silty sands. Sections constructed from the boring logs indicated that the sand and gravel unit is the major medium for the aquifer (see Figures 11 - 30).

(7) The field drilling operation identified the bedrock contact at 257 locations in the study area. From this data, both a bedrock contour map and transect map were constructed (Figures 5 and 6). The bedrock contours indicate that the Denver-Arapahoe unit slopes generally from southeast to northwest. In detail, the bedrock surface is irregular with numerous channels and gullies apparent. The study area overlies two major channels. The channel which has the most influence in the hydrology of the study area lies on the eastern edge of Sections 34, 27, and 22. The second channel is located on the southwestern

INVESTIGATION OF THE NORTHWEST AREA OF RMA - Cont

corner of the study area. Both channels are characterized by the close contour intervals on the bedrock contour map, Figure 5. The small irregularities of the bedrock surface are very likely due to the erosional characteristic of the material. The erosional forces moved the sand and silty sand bedrock materials easier than the clay and silty clay materials. With the formation of interbedded layers of these materials, the potential for an irregular erosional surface to be developed exists. The patterns of the erosional forces are also responsible for the irregular bedrock surface

b. Hydrology

(1) The study area is situated on the east side of the South Platte River Basin. Groundwater movement through this region is from southeast to northwest towards the South Platte River. The groundwater-flow system for the study area is complexed by local bedrock highs with unsaturated alluvium and the saturated alluvium of the bedrock lows. The groundwater-flow pattern is governed by the permeability properties of the aquifer materials and the configuration of bedrock. In some cases, the flow of groundwater can be controlled solely by the bedrock erosional surface. This condition exists in locations where the saturated thickness is small and the bedrock slope is great.

(2) Water-level hydrographs of wells in the region indicate that there has been no long-term change in the water level for the region since 1937. The only major drop in water levels occurred during a drought in 1954-57 when water levels dropped about three feet. The water levels returned to normal levels after the drought.

(3) Some localized effect of groundwater levels could have been created by the diversion of water into disposal ponds on the Arsenal. The diversion of water into these ponds has ceased, but the surface run-off from the rain and snow maintains surface water in most ponds year around. This water eventually recharges the aquifer and affects the water regime within the study area.

(4) The installation of monitoring wells in the study area was limited to the observation of the upper most (shallow) aquifer. The observed irregularities of the water table are most probably due to the bedrock configuration, nonuniformity of the aquifer, and the recharge from ponds.

(5) Water levels were monitored on the study area for two years, and only minor fluctuations in water levels were recorded. The small variations in water levels indicate the relative stability of the groundwater system. These water levels were used in constructing both a water table contour map and transect map (Figures 7 and 8). Close comparison of the bedrock contour map (Figure 5) and the water table contour map (Figure 7) shows that groundwater flow in the

INVESTIGATION OF THE NORTHWEST AREA OF RMA - Cont

study area is affected by the bedrock configuration. There are several areas within the study area where the bedrock surface is above the water table.

(6) Groundwater flowing into the study area can be associated with two sources or flow systems. The major source of water which flows into the northwest area enters from the south to southeast. Large quantities of water move along the southern parts of the Arsenal towards the northwest. The second flow source originates from the Basin A region and flows west and/or northwest towards the RMA boundary.

(7) The quantity of water flowing across the northwest boundary was computed from the data base used for the generation of the contour maps. A file matrix of water table gradients perpendicular to the northwest boundary was constructed and placed in the computer. This data was combined with saturated thickness and aquifer permeability to construct a flow intensity matrix (see Figures 9 and 10). With this data, the quantity of water moving in the northwest direction, perpendicular to the northwest boundary, can be computed.

c. Water Chemistry

(1) The quality of the groundwater was assessed from water samples collected within the study area. The northwest area of the Arsenal included wells from Sections 22, 27, and 33, parts of Sections 23, 26, and 35, and off-post sites (Table 1, Figure 2).

(2) Table 2 presents results of well water quality analyses. In addition to the constituents appearing in Table 2, results were available for five sulfur compounds and chlorinated pesticides. The sulfur compounds and chlorinated pesticides were rarely detected and at very low levels. Well 22-12 contained 0.59 ppb Dieldrin and 1.06 ppb Endrin. Several wells adjacent to Basin F contained low levels (less than 80 ppb) of Sulfone.

(3) Table 3 lists wells which had high concentrations of DIMP or fluoride, or in which DCPD or Nemagon was observed. Table 4 lists these values. High levels of DIMP were considered to be 250 ppb, Fluoride was 2.4 ppm (water standard). The DIMP criteria is one-half the present recommended "maximum permitted" (500 ppb). This concentration, however, gave a more informative overview of DIMP distribution within the study area.

(4) High fluoride levels were observed throughout the study area (Table 4, Figures 31 and 32). High concentrations were detected in wells adjacent to the Arsenal boundary in Section 22. The quantity of water moving off post in the portion of the area having significant water flow was calculated using the

INVESTIGATION OF THE NORTHWEST AREA OF RMA - Cont

flow intensity matrix. From half way between borings 304 and 343 to half way between 297 and 296, it was approximately 941 cubic feet per day. From that latter point to half way between borings 288 and 287 (Figure 3), the flow was 507 cubic feet per day. The very limited number of off-post wells in the area of Section 22 boundary wells did not contain elevated fluoride levels. Interior wells in Section 27 also had high fluoride levels. Wells in this Section at the Arsenal boundary and at the boundary of Sections 28 and 33, however, contained only low fluoride concentrations.

(5) High DIMP levels were detected at the edge of Basin F and in an area extending northwest from the northwest corner of that Basin (Table 4, Figures 33 and 34). Few high DIMP values were observed along the E-E' line. Well 27-23 had the highest value, but this sample was recovered from a hole drilled deeply into bedrock. This may be an accurate value or result from a concentration artifact as seepage into the hole evaporates. This well can only be sampled when long-time periods pass between sampling efforts to allow water build up. DIMP was observed along the northwest boundary, but at only extremely low levels.

(6) DCPD was very rarely observed (Table 4 and Figure 35), essentially only along the E-E' line. It was also normally only observed on the first analysis. Most of the positive results were obtained when the standard was later determined to be defective. DCPD, however, was detected when the standards were correct. The most recent sampling was negative.

(7) Nemagon was observed at several sampling sites (Table 4 and Figure 36) in very small amounts. Wells in Sections 22, 26, 27, and 33 contained DBCP.

(8) Table 2 lists the data for the remaining constituents. Figures 37, 38, and 39 depict the distribution of Sodium, Chloride, and Sulfate in the study area. As the objective of this paper was to provide information about pollutants, these remaining parameters are not individually discussed.

7. Discussion

a. The water quality analyses are from a shallow aquifer. On-going drilling in the area south of Basin F (Basin A neck) is concerned with both a shallow and a deep aquifer. The degree of pollution, if any, in the deep aquifer is unknown. Discovery of pollution in that aquifer would indicate that a similar effort is warranted in the northwest area of RMA. A well penetrating into the deep aquifer at the extreme southwest corner of Section 26 (26-62) revealed no significant pollution. However, this is only a single observation.

INVESTIGATION OF THE NORTHWEST AREA OF RMA - Cont

b. This study showed that only Fluoride existed at the Arsenal boundary at levels exceeding the groundwater standard. It is difficult to believe that discharge above the accepted limit is not occurring, despite the fact that off-post wells did not contain elevated levels. The off-post wells are not positioned at the boundary like the on-post wells. The source of the Fluoride, natural or the result of industry, is unknown.

c. High DIMP levels were observed along the edge of Basin F or in an area extending northwest of the northwest corner of the Basin. The question is whether DIMP is advancing. The area of concern does not reach the Arsenal boundary. A review of the Jun 77 USGS publication, "Digital-Model Study of Groundwater Contamination by DIMP, RMA, near Denver, Colorado - Final Report" indicates that concentrations above 200 ppb should not be observed in that portion of the study area, based upon the assumption that no additional DIMP input occurred beside the original source. The Report concluded that high DIMP levels observed in the northwest resulted from a secondary source. The Report indicated that insufficient information prevented identification of the mechanism or source(s) for this contamination. Possibilities were:

- (1) A leak in the Basin F liner or other associated reservoir structures.
- (2) Migration of contaminated water through permeable zones in an underlying bedrock formation.
- (3) Percolation in Ponds C, D, or E of contaminated surface run-off from Ponds A or B.
- (4) Release of contaminants previously concentrated in soil by sorbtion or evaporation of water.

The extremely low levels of DIMP at the boundary are most likely residual contamination from already exited pollution.

d. The status of DCPD cannot be resolved without careful further sampling. Initial sampling was normally the only sample in which the substance was detected, and the standards were later discovered to be faulty. In some instances, however, DCPD was observed in a second analyais; and the standards were correct. Other subsequent analyses were negative. Which effort is correct?

e. DBCP (Nemagon) was detected at generally less than a ppb in a few wells scattered throughout the study area. It was not detected in the limited number of possible off-post wells. Well 22-5 is a site of the on-going Nemagon sampling program; however, wells in Sections 27 and 33 are not included. These results,

INVESTIGATION OF THE NORTHWEST AREA OF RMA - Cont

coupled with other RMA-wide sampling, are beginning to demonstrate that this substance is widespread on the Arsenal and may represent an expanding problem because of the hazardous nature of DBCP.

f. This study, of necessity, was limited to the number of constituents investigated. Of concern, is the possibility of missing an important study parameter. If, as generally conceded, Basin F is leaking compounds into the northwest area (see discussion about DIMP above), the problem requires resolution. A study of pollutants in Basin F showed that the effluent contained approximately 16 ppm DIMP but also approximately 1,200 ppm DMMP (dimethyl methyl phosphonate). As the latter is approximately 100 times the former, the compound of concern may be DMMP instead of DIMP at this location.

8. Conclusions - The conclusions of this report are based upon data available to the study area at this time. They may change as work in areas adjacent to the study area is completed.

a. The drilling adequately defined the bedrock surface of the study area. The minor irregularity of the erosional bedrock surface did not appear to affect groundwater flow; therefore, the general bedrock surface was used for the system evaluation.

b. Saturated zones can exist in the bedrock. The bedrock contact in parts of the study area were determined to be saturated bedrock sands, thus providing a hydraulic connection between near surface aquifers and permeable bedrock zones.

c. Groundwater flow is affected by both the general bedrock topography and the aquifer physical properties.

(1) The region where groundwater is most affected by the bedrock surface lies along the eastern sections of the study area. These areas are characterized by steep sloping bedrock and water table, thin saturated thickness, and high flow intensity.

(2) The region where groundwater is least affected by bedrock topography lies along the western sections of the study area. These areas have level bedrock and water table and large saturated thicknesses.

d. Fluoride is egressing the Arsenal along parts of Section 22 above accepted groundwater standards. Its origin, natural or industry, is unknown.

e. High DIMP levels exist in an area northwest of the northwest corner of Basin F. This DIMP may have leaked out of Basin F (or other source) and be moving towards the Arsenal boundary. Insufficient information presently precludes confirmation of this possibility. DIMP was detected along the northwest boundary at very low levels. Review of literature suggests this is residual contamination.

INVESTIGATION OF THE NORTHWEST AREA OF RMA - Cont

f. The occurrence or absence of DCPD in the study area has not been resolved because of sampling problems. Most results suggest that DCPD is absent.

g. DBCP (Nemagon) is widely distributed but only at extremely low levels. Limited off-post sampling sites preclude a complete determination that it has not migrated off post at the northwest boundary. DBCP, however, was not detected in these few off-post wells.

h. The likelihood of leakage from Basin F suggests that additional compounds should be analyzed for in northwest area wells. DMMP exists in extremely high concentrations in Basin F. If Basin F leaks constituents to the northwest, large amounts of DMMP may be entering the study area.

9. Recommendations - The recommendations of this report are based upon data available to the study area at this time. They may change as work in areas adjacent to the study area is completed.

a. Work may be required on two major tasks: (1) Identify the permeable zones within the bedrock and establish whether contaminated water exists in these sediments. (2) Determine the hydrological interface between the near surface aquifer(s) and permeable bedrock zone(s).

b. Sample fluoride on a periodic basis, perhaps every six months, to monitor its status. Present 360° monitoring wells could partially satisfy this requirement; however, its distribution is widespread enough to add other sampling sites.

c. Sample wells where DCPD was detected previously and conduct careful MS/GC analyses. These results should demonstrate the presence/absence of this compound.

d. Sample wells containing high DIMP levels on a periodic basis, perhaps every six months, to monitor its status until satisfied that the data indicates that a possible problem does not exist northwest of Basin F.

e. Add wells (e.g., Sections 27 and 33) to the Nemagon-sampling program.

f. Sample wells at the Basin F boundary and conduct careful MS/GC analyses. These results should uncover other possible contaminants entering the northwest Arsenal area.

TABLE 1. LIST OF SAMPLE SITES IN THE NORTHWEST AREA
OF RMA

<u>Section</u>	<u>Well No.</u>	<u>Boring No.</u>
22	22-1	2
	22-2	39
	22-3	104
	22-4	105
	22-5	108
	22-6	302
	22-7	1
	22-8	43
	22-9	69
	22-10	292
	22-11	303
	22-12	356
	22-13	671
	22-14	672
23	23-2	71
	23-107	612
	23-108	613
	23-109	614
26	26-1	62
	26-2	142
	26-3	125
	26-4	41
	26-5	98
	26-6	141
	26-16	410
	26-17	414
	26-18	418
	26-19	421
	26-20	422
	26-21	423
	26-22	425
	26-23	426
	26-24	430
	26-25	436
26-62	660	

TABLE 1. LIST OF SAMPLE SITES IN THE NORTHWEST AREA OF RMA - Cont

27	27-1	103
	27-2	99
	27-3	24
	27-4	304
	27-5	305
	27-6	306
	27-7	307
	27-8	308
	27-9	309
	27-10	342
	27-11	343
	27-12	615
	27-13	616
	27-14	617
	27-16	619
	27-17	620
	27-18	621
	27-23	626
	27-24	627
	27-25	628
	27-26	629
	27-27	630
	27-28	631
	27-29	632
	27-30	633
	27-31	634
	27-33	636
	27-34	637
	27-35	638
	27-36	639
	27-37	661
	27-40	663
	27-41	664
	27-42	665
	27-43	666
	27-44	668
	27-45	669
	27-49	675

TABLE 1. LIST OF SAMPLE SITES IN THE NORTHWEST AREA OF PMA - Cont

28	28-1	310
	28-2	311
	28-3	312
	28-4	313
	28-5	314
	28-6	315
	28-7	316
	28-8	317
	28-9	318
	28-10	319
	28-11	320
	28-12	321
	28-13	322
	28-14	323
	28-15	324
	28-16	325
	28-17	326
	28-18	327
	28-19	328
	28-20	329
	28-21	330
	28-22	667
33	33-1	38
	33-2	50
	33-3	331
	33-4	332
	33-5	333
	33-6	334
	33-7	335
	33-8	336
	33-9	337
	33-10	338
	33-11	339
	33-12	340
	33-13	341
35	35-4	139
	35-5	17
	35-6	15
	82	NA ¹
	84	NA
	LV	NA
	XXVIII	NA
	XXXI	NA
XXXII	NA	

1 NA - Not Applicable

TABLE 2. RESULTS OF WATER QUALITY ANALYSES IN THE
NORTHWEST AREA OF RMA

<u>Sample No.</u>	<u>Constituent 1,2,3,4,5</u>							
	<u>DIMP</u>	<u>DCPD</u>	<u>Na</u>	<u>Cl</u>	<u>SO4</u>	<u>NO3</u>	<u>F</u>	<u>DBCP</u>
22-1 (2)	275 580	ND	263 310	162 210	122 155	1.03 1.6	6.14 7.8	ND
22-2 (39)	2.01 8.2	ND	552 766	282 330	1,341 1,510	6.36 9.0	.46 .62	ND
22-3 (104)	10.23 28.7	ND	352 444	430 651	193 250	3.43 4.7	2.53 2.93	ND
22-4 (105)	2.94 4.6	ND	252 300	132 160	127 150	.21 .29	7.49 8.48	ND
22-5 (108)	8.38 16	ND	410 478	627 840	247 313	2.57 4.4	2.24 3.65	.58 1.43
22-6 (302)	20.83 26	ND	756 957	199 225	1,811 2,020	6.21 6.8	5.18 6.75	ND
22-7 (1)	82	ND	290	162	NR	ND	1.81	ND
22-8 (43)	115 226	ND	441 469	750 790	251 252	1.93 2.35	3.6 3.6	.39 .77
22-9 (69)	3.2 3.7	ND	120 123	141 142	27 30	3.72 5.1	1.0 1.0	ND
22-10 (292)	9.4 10	ND	281 307	396 460	226 230	.17 .3	2.44 2.44	ND
22-11 (303)	5.9 6.5	ND	258 262	141 142	138 140	.19 .21	6.05 6.05	ND
22-12 (356)	19.7 28	319 958	310 331	156 174	29 66	.03 .09	1.6 1.6	ND
22-13 (671)	15.3	ND	432	701	268	3.29	3.0	ND

TABLE 2. RESULTS OF WATER QUALITY ANALYSES IN THE NORTHWEST AREA OF RMA - Cont

22-14 (672)	313	ND	447	411	468	ND	5.28	ND
23-2 (71)	338 348	ND	274 295	196 269	219 300	.09 .16	5.84 6.6	ND
23-107 (612)	50 56	ND	230 230	221 234	109 118	ND	5.7 5.9	ND
23-108 (613)	216 217	ND	256 260	187 192	112 127	ND	6.5 7.2	ND
23-109 (614)	10 20	ND	82 140	38.9 43.5	45 45	ND	3.0 3.6	ND
26-1 (62)	758 1,413	ND	294 498	340 929	152 275	.45 .85	3.71 4.55	ND
26-2 (142)	60.3 193	ND	477 804	723 1,320	307 560	.31 .88	2.6 4.09	ND
26-3 (125)	101 140	ND	525 680	862 955	335 455	.52 .80	2.54 2.80	ND
26-4 (41)	850 2,108	3.83 27	550 800	677 1,480	299 412	.09 .25	4.38 5.32	ND
26-5 (98)	3,191 6,906	ND	1,174 1,400	1,582 2,600	648 800	8.55 16.0	2.21 2.75	ND
26-6 (141)	2,260 2,696	ND	639 1,200	873 1,650	560 1,120	3.71 9.5	1.68 2.6	1.37 2.57
26-16 (410)	1,100	ND	411	570	260	1.5	3.2	NR
26-17 (414)	1,400	ND	502	780	180	7.9	1.65	NR
26-18 (418)	327	ND	392	580	127	21	3.6	NR
26-19 (421)	67 74	ND	496 526	820 840	313 334	.35 .65	3.76 3.96	NR
26-20 (422)	3,520	ND	362	640	125	2.6	2.1	NR

TABLE 2. RESULTS OF WATER QUALITY ANALYSES IN THE NORTHWEST AREA OF RMA - Cont

26-21 (423)	320	ND	500	880	336	.72	2.6	NR
26-22 (425)	1,860	ND	760	1,700	325	ND	2.76	NR
26-23 (426)	154 188	ND	541 636	720 920	306 412	.36 .60	3.5 3.6	NR
26-24 (430)	307 495	ND	1,103 1,426	1,660 1,960	1,012 1,380	30 33	3.35 3.44	NR
26-25 (436)	108	ND	338	432	167	.98	4.4	NR
26-62 (660) DEEP	.54	ND	222	171	169	7.30	2.27	ND
27-1 (103)	.29 2.6	ND	93 105	119 250	82 115	.79 1.86	.84 1	ND
27-2 (99)	3.4 5.95	ND	237 310	379 460	145 193	4.53 5.60	1.35 1.5	ND
27-3 (24)	1.44 7.5	ND	86 97	102 110	66 97	.56 1.7	.84 1.15	ND
27-4 (304)	1.21	ND	82	85	80	.05	1.12	ND
27-5 (305)	1.02	ND	99	116	79	ND	1.27	ND
27-6 (306)	1.78	ND	93	114	71	.07	1.17	ND
27-7 (307)	1.41	ND	27	43	53	.07	.86	ND
27-8 (308)	1.13	ND	71	85	65	.04	1.08	ND
27-9 (309)	.94	ND	51	60	65	.10	1.06	ND
27-10 (342)	.77	ND	24	38	30	.04	.85	ND
27-11 (343)	.88	ND	34	48	36	.11	.94	ND
27-12 (615)	173	ND	410	492	33	.045	1.79	ND
27-13 (616)	78 79	634 963	402 410	460 494	966 1,170	.06 .1	2.9 3.5	ND

TABLE 2. RESULTS OF WATER QUALITY ANALYSES IN THE NORTHWEST AREA OF RMA - Cont

27-14 (617)	57 48	ND	345 360	241 245	171 174	1.9 1.9	3.85 4.1	ND
27-16 (619)	488 592	323 970	277 282	184 193	149 160	.88 1.35	12.07 12.4	ND
27-17 (620)	48 49	ND	795 840	982 1,074	353 440	.03 .06	3.2 3.8	ND
27-18 (621)	207 281	ND	645 670	1,094 1,100	425 520	.08 .15	2.4 2.7	ND
27-23 (626)	1,840	ND	417	611	255	.045	2.87	ND
27-24 (627)	44 48	ND	680 720	1,194 1,210	450 570	.34 .68	2.0 2.0	.65 .74
27-25 (628)	33 33	ND	675 720	1,342 1,383	434 570	2.4 3.0	1.9 1.9	.9 1.04
27-26 (629)	54 56	315 946	659 690	1,335 1,465	451 590	2.87 3.0	2.2 2.8	.98 1.31
27-27 (630)	108 200	232 930	418 490	1,071 1,271	260 324	.22 .55	1.87 2.0	ND
27-28 (631)	42 49	221 833	299 310	700 711	174 177	1.08 2.7	2.2 2.8	ND
27-29 (632)	7.2 9.5	ND	397 449	544 658	203 218	3.3 3.8	2.58 2.85	ND
27-30 (633)	4.0	ND	295	319	154	ND	2.83	ND
27-31 (634)	1.5	ND	267	378	160	1.63	1.8	ND
27-33 (636)	.51	ND	160	211	64	.04	.91	ND
27-34 (637)	ND	ND	ND	15	ND	ND	1.9	ND
27-35 (638)	.7	ND	170	300	112	2.7	2.0	ND
27-36 (639)	.5	ND	41	50	13	.11	1.3	ND

TABLE 2. RESULTS OF WATER QUALITY ANALYSES IN THE NORTHWEST AREA OF RMA - Cont

27-37 (661)	ND	ND	95 165	179 295	52 75	1.4 2.8	.98 1.17	ND
27-40 (663)	35 39	ND	616 662	1,067 1,085	463 546	.13 .26	2.18 2.21	.4 .8
27-41 (664)	8.6 8.9	ND	319 338	454 464	199 203	4.72 4.79	2.25 2.27	ND
27-42 (665)	ND	ND	49 53	91 105	45 50	ND	.92 .93	ND
27-43 (666)	.3 .6	ND	5.5 11	12 24	21 24	ND	.78 .79	ND
27-44 (668)	6.7 13.4	ND	74 74	87 96	41 42	.028 .055	1.24 1.25	ND
27-45 (669)	1.04 .67	ND	ND	10 20	20 28	ND	.73 .73	ND
27-49 (675)	3.5 5.7	ND	78 114	119 167	62 78	ND	1.19 1.36	ND
28-1 (310)	1.07	ND	86	93	50	ND	1.26	ND
28-2 (311)	1.75	ND	33	85	67	.05	1.14	ND
28-3 (312)	1.02	ND	84	97	73	.05	1.23	ND
28-4 (313)	.92	ND	31	43	73	.22	1.17	ND
28-5 (314)	.83	ND	74	64	104	ND	1.03	ND
28-6 (315)	.78	ND	74	55	148	ND	1.17	ND
28-7 (316)	.77	ND	77	60	239	ND	1.03	ND
28-8 (317)	1.13	ND	69	57	240	ND	1.49	ND
28-9 (318)	.83	ND	95	52	70	ND	1.03	ND
28-10 (319)	.73	ND	84	48	238	.07	.97	ND

TABLE 2. RESULTS OF WATER QUALITY ANALYSES IN THE NORTHWEST AREA OF RMA - Cont

28-11 (320)	.80	ND	72	42	173	ND	.82	ND
28-12 (321)	.84	ND	69	43	123	ND	.78	ND
28-13 (322)	.81	ND	63	45	111	.05	.81	ND
28-14 (323)	.90	ND	74	43	107	.10	.89	ND
28-15 (324)	.75	ND	66	46	105	.04	.81	ND
28-16 (325)	.9	ND	69	47	106	ND	.82	ND
28-17 (326)	.81	ND	77	45	112	ND	.74	ND
28-18 (327)	.82	ND	72	47	92	.22	.8	ND
28-19 (328)	.89	ND	38	45	51	.05	.8	ND
28-20 (329)	1.06	ND	82	48	62	.05	1.14	ND
28-21 (330)	1.0	ND	69	51	106	ND	.72	ND
28-22 (667)	ND	ND	56	50	130	4.3	.78	ND
33-1 (38)	.49 3.4	ND	90 176	46 88	164 317	6.1 7.2	.6 .93	.19 .58
33-2 (50)	.36 3.1	ND	154 173	102 120	345 450	3.45 4.8	.48 .75	ND
33-3 (331)	1	ND	69	53	102	ND	.87	ND
33-4 (332)	.9	ND	65	57	103	ND	1.06	ND
33-5 (333)	1.05	ND	66	100	1,250	ND	.92	ND
33-6 (334)	.95	ND	66	57	106	.05	.95	ND
33-7 (335)	1.22	ND	71	62	110	.14	.8	ND
33-8 (336)	1.55	ND	69	64	120	ND	.79	ND
33-9 (337)	1.2	ND	63	63	123	ND	.75	ND

TABLE 2. RESULTS OF WATER QUALITY ANALYSES IN THE NORTHWEST AREA OF RMA - Cont

33-10 (338)	.82	ND	51	66	112	3.2	.68	ND
33-11 (339)	.85	ND	58	51	145	ND	.75	ND
33-12 (340)	.92	ND	44	45	119	ND	.81	ND
33-13 (341)	1.75	ND	36	40	105	ND	.95	ND
35-4 (139)	61 80	ND	535 625	1,091 1,155	275 300	2.21 2.5	1.6 1.94	NR
35-5 (17)	18.7 71	ND	368 440	837 1,140	225 248	2.07 2.81	1.41 2.54	ND
35-6 (15)	.59 2.4	ND	165 195	86 97	170 225	1.24 2.10	1.86 2.25	ND
82	ND	ND	139	170	170	.19	1.25	ND
84	10.7 15	ND	117 125	135 167	152 158	8.2 8.6	NR	NR
LV	23.9 22	ND	217 300	275 345	197 320	7.09 9.35	2.19 2.38	ND
XXVIII	ND	ND	107 163	131 250	126 180	8.05 25.0	1.13 1.95	ND
XXXI	ND	ND	69 76	67 77	145 180	7.01 10.0	.64 .9	ND
XXXII	ND	ND	73 89	51 58	179 263	4.89 7.25	.74 1.04	ND

1 - DIMP - diisopropylmethyl phosphonate, DCPD - dicyclopentadiene, DBCP - dibromochloro-propane, Na-sodium, Cl- chloride, SO4-sulfate, NO3-nitrate, F-fluoride

2 - 22-1, Well number; (2), Boring number

3 - ND - not detected, NR - not run

4 - DIMP, DCPD, DBCP-ppb, others - ppm

5 - A single line of values indicates that only one observation is available; two lines of values indicate that at least two observations are available. The top of two lines is the average value, the bottom value is the highest value.

TABLE 3. LIST OF WELLS CONTAINING SIGNIFICANT CONCENTRATIONS OF DIMP OR FLUORIDE OR IN WHICH DCPD OR DBCP WAS DETECTED

<u>Constituent</u> ^{1,2}			
<u>DIMP</u>	<u>DCPD</u>	<u>DBCP</u>	<u>F</u>
22-1 (2)	22-12 (356)	22-5 (108)	22-1 (2)
22-14 (672)	26-4 (41)	22-8 (43)	22-3 (104)
23-2 (71)	27-13 (616)	26-6 (141)	22-4 (105)
23-108 (613)	27-16 (619)	27-24 (627)	22-5 (108)
26-1 (62)	27-26 (629)	27-25 (628)	22-6 (302)
26-4 (41)	27-27 (630)	27-26 (629)	22-8 (43)
26-5 (98)	27-28 (631)	27-40 (663)	22-10 (292)
26-6 (141)		33-1 (38)	22-11 (303)
26-16 (410)			22-13 (671)
26-17 (414)			22-14 (672)
26-18 (418)			23-2 (71)
26-19 (421)			23-107 (612)
26-20 (422)			23-108 (613)
26-21 (423)			23-109 (614)
26-22 (425)			26-1 (62)
26-24 (430)			26-2 (142)
27-16 (619)			26-3 (125)
27-18 (621)			26-4 (41)
27-23 (626)			26-5 (98)
			26-6 (141)
			26-16 (410)
			26-18 (418)
			26-19 (421)
			26-21 (423)
			26-22 (425)
			26-23 (426)
			26-24 (430)
			26-25 (436)
			27-13 (616)
			27-14 (617)
			27-16 (619)
			27-17 (620)
			27-18 (621)
			27-23 (626)
			27-26 (629)
			27-28 (631)
			27-29 (632)
			27-30 (633)
			35-5 (17)

1 - DIMP - diisoprophylmethyl phosphonate, DCPD-dicyclopentadiene, DBCP - dibromo-chloropropane, F-fluoride

2 -22-1, Well number; (2), Boring number

TABLE 4. WELLS CONTAINING SIGNIFICANT CONCENTRATIONS OF
DIMP OR FLUORIDE OR IN WHICH DCPD OR DBCP
WAS DETECTED

<u>Sample No.</u>	<u>Constituent</u> 1,2,3,4,5,6			
	<u>DIMP</u>	<u>DCPD</u>	<u>DBCP</u>	<u>F</u>
22-1 (2)	275 580	NA	NA	6.14 7.8
22-3 (104)	NA	NA	NA	2.53 2.93
22-4 (105)	NA	NA	NA	7.49 8.48
22-5 (108)	NA	NA	.58 1.43	2.24 3.65
22-6 (302)	NA	NA	NA	5.18 6.75
22-8 (43)	NA	NA	.39 .77	3.6 3.6
22-10 (292)	NA	NA	NA	2.44 2.44
22-11 (303)	NA	NA	NA	6.05 6.05
22-12 (356)	NA	319 958	NA	NA
22-13 (671)	NA	NA	NA	3.0
22-14 (672)	313	NA	NA	5.28
23-2 (71)	338 348	NA	NA	5.84 6.6
23-107 (612)	NA	NA	NA	5.7 5.9
23-108 (613)	216 217	NA	NA	6.5 7.2

TABLE 4. WELLS CONTAINING SIGNIFICANT CONCENTRATIONS OF DIMP OR FLUORIDE OR IN WHICH DCPD OR DBCP WAS DETECTED - Cont

23-109 (614)	NA	NA	NA	3.0 3.6
26-1 (62)	758 1,413	NA	NA	3.71 4.55
26-2 (142)	NA	NA	NA	2.6 4.09
26-3 (125)	NA	NA	NA	2.54 2.80
26-4 (41)	850 2,108	3.83 27	NA	4.38 5.32
26-5 (98)	3,191 6,906	NA	NA	2.21 2.75
26-6 (141)	2,260 2,696	NA	1.37 2.57	1.68 2.6
26-16 (410)	1,100	NA	NA	3.2
26-17 (414)	1,400	NA	NA	NA
26-18 (418)	327	NA	NA	3.6
26-19 (421)	NA	NA	NA	3.76 3.96
26-20 (422)	3,520	NA	NA	NA
26-21 (423)	320	NA	NA	2.6
26-22 (425)	1,860	NA	NA	2.76
26-23 (426)	NA	NA	NA	3.5 3.6
26-24 (430)	307 495	NA	NA	3.35 3.44

TABLE 4. WELLS CONTAINING SIGNIFICANT CONCENTRATIONS OF DIMP OR FLUORIDE OR IN WHICH DCPD OR DBCP WAS DETECTED - Cont

26-25 (436)	NA	NA	NA	4.4
27-13 (616)	NA	634 963	NA	2.9 3.5
27-14 (617)	NA	NA	NA	3.85 4.1
27-16 (619)	488 592	323 970	NA	12.07 12.4
27-17 (620)	NA	NA	NA	3.2 3.8
27-18 (621)	207 281	NA	NA	2.4 2.7
27-23 (626)	1,840	NA	NA	2.87
27-24 (627)	NA	NA	.65 .74	NA
27-25 (628)	NA	NA	.9 1.04	NA
27-26 (629)	NA	315 946	.98 1.31	2.2 2.8
27-27 (630)	NA	232 930	NA	NA
27-28 (631)	NA	221 833	NA	2.2 2.8
27-29 (632)	NA	NA	NA	2.58 2.85
27-30 (633)	NA	NA	NA	2.83
27-40 (663)	NA	NA	.4 .8	NA
33-1 (38)	NA	NA	.19 .58	NA

TABLE 4. WELLS CONTAINING SIGNIFICANT CONCENTRATIONS OF DIMP OR FLUORIDE OR IN WHICH DCPD OR DBCP WAS DETECTED - Cont

35-5 (17)	NA	NA	NA	1.41 2.54
-----------	----	----	----	--------------

1 - DIMP - diisopropylmethyl phosphonate, DCPD - dicyclopentadiene, DBCP - dibromochloro-propane, F - fluoride

2 - DIMP, DCPD, DBCP-ppb, F-ppm

3 - NA - not applicable

4 - 22-1, Well number; (2), Boring number

5 - A single line of values indicates that only one observation is available; two lines of values indicate that at least two observations are available. The top value of two lines is the average value, the bottom value is the highest value.

6 - Significant value: DIMP - 250 ppb, F - 2.4 ppm

LITERATURE CITED

US Army Engineer District, Omaha, Corps of Engineers. Program for Reclamation of Surface Aquifer, Jan 61.

US Department of Army, Off-Post Contamination Control Plan, 30 May 75.

Konikow, Leonard F., US Geological Survey, Modeling Solute Transport in Groundwater, Sep 75.

Robson, S.G., US Geological Survey, Digital-Model Study of Groundwater Contamination by Diisoprophylmethyl phosphonate (DIMP), Rocky Mountain Arsenal near Denver, Colorado -- Final Report, Jun 77.

Arndt, B. M., US Department of Army, Rocky Mountain Arsenal, Interim Report on Basin F, Mar 78.

Arndt, B. M., US Department of Army, Rocky Mountain Arsenal, Interim Report on Groundwater Quality at the Northwest Boundary of RMA, Apr 78.

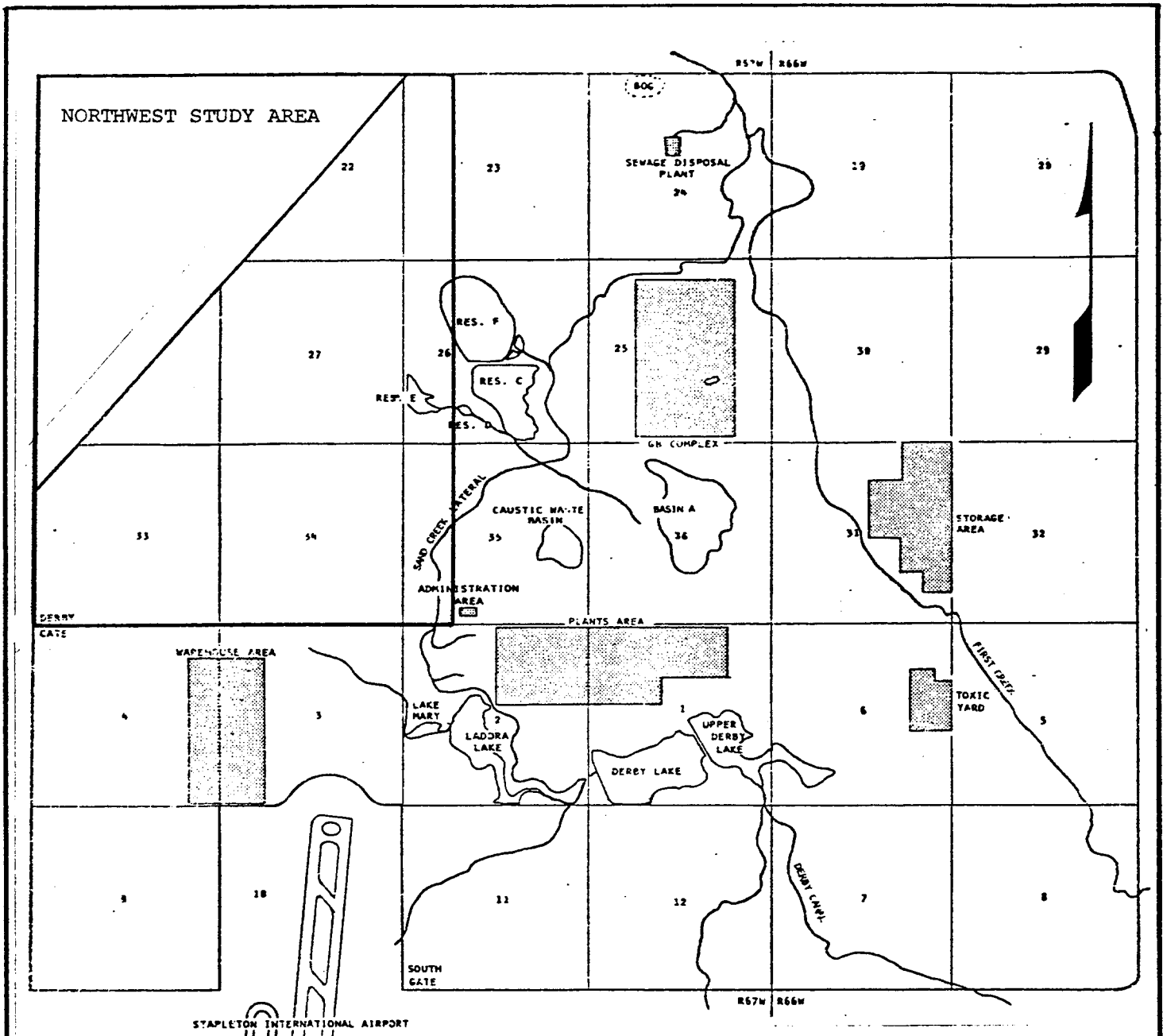

STAPLETON INTERNATIONAL AIRPORT

UNITED STATES ARMY
 ROCKY MOUNTAIN ARSENAL
 COMMERCE CITY, COLORADO

CONTAMINATION MIGRATION DIV.

GEOHYDROLOGY BRANCH

GROUNDWATER CONTAMINATION
 MIGRATION FOR THE
 NORTHWEST AREA OF RMA
 SITE LOCATION MAP

SCALE: None

APPROVED

DATE Oct 78

FIGURE 1

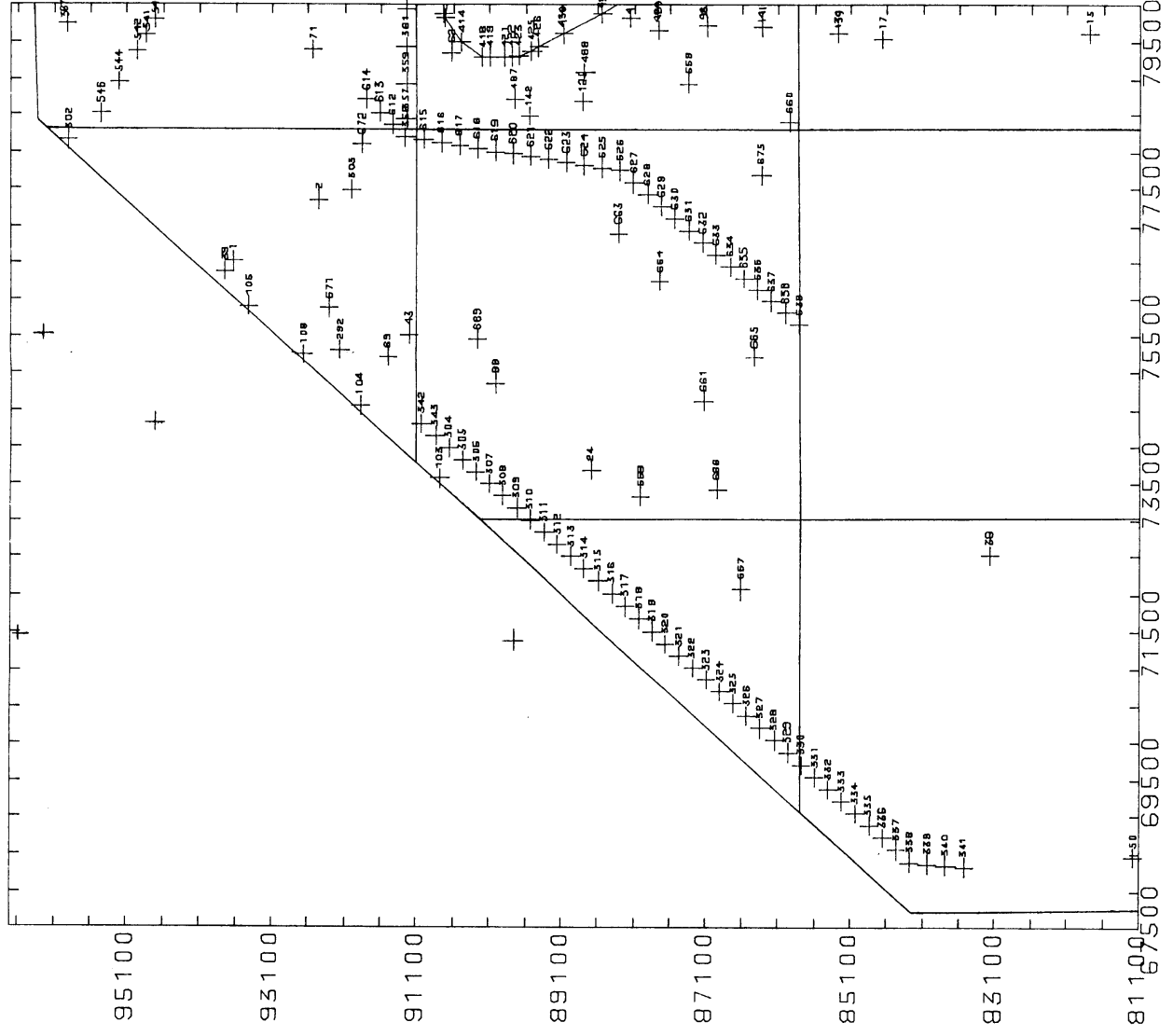

* NORTH-WEST QUADRANT STUDY AREA - CASED BORINGS
 PLOT NO. 1 DATE 10/25/78 TIME 12.01.37

CONTAMINATION MIGRATION DIV.
 UNITED STATES ARMY
 ROCKY MOUNTAIN ARSENAL
 COMMERCE CITY, COLORADO
 "CONDUIT" BRANCH

GROUNDWATER CONTAMINATION
 MIGRATION FOR THE
 NORTHWEST AREA OF RMA
 WELL LOCATION MAP

SCALE: AS SHOWN	APPROVED	DATE Oct. 78
--------------------	----------	-----------------

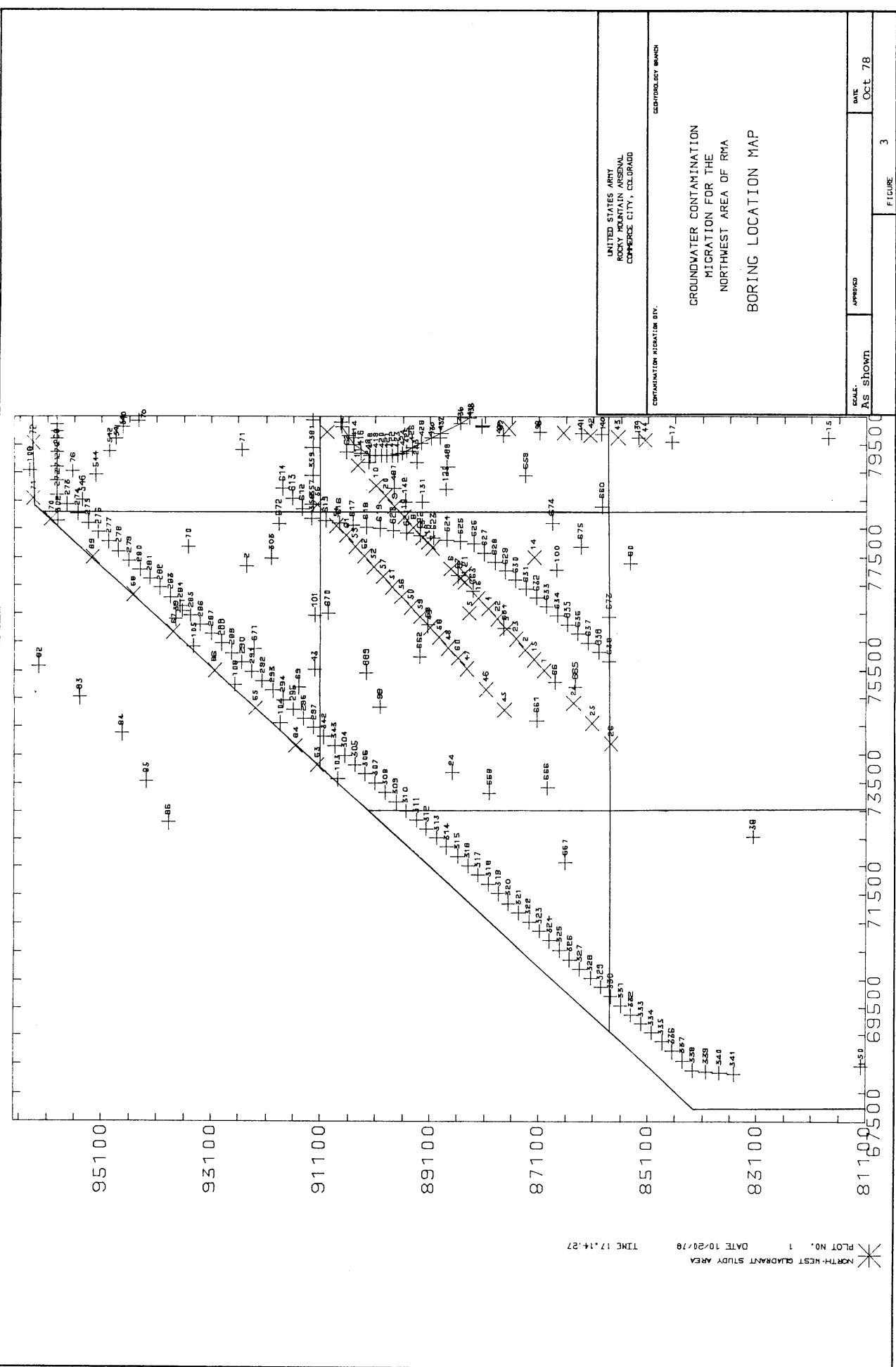

NORTH-NEST PLUQUANT STUDY AREA
 DATE 10/20/78
 TIME 17.14.27

CONTAMINATION MIGRATION DIV.
 UNITED STATES ARMY
 ROCKY MOUNTAIN ARSENAL
 COMMERCE CITY, COLORADO

GSEHYDROLOGY BRANCH

GROUNDWATER CONTAMINATION
 MIGRATION FOR THE
 NORTHWEST AREA OF RMA
 BORING LOCATION MAP

SCALE: AS SHOWN
 APPROVED
 DATE: OCT 78
 FIGURE 3

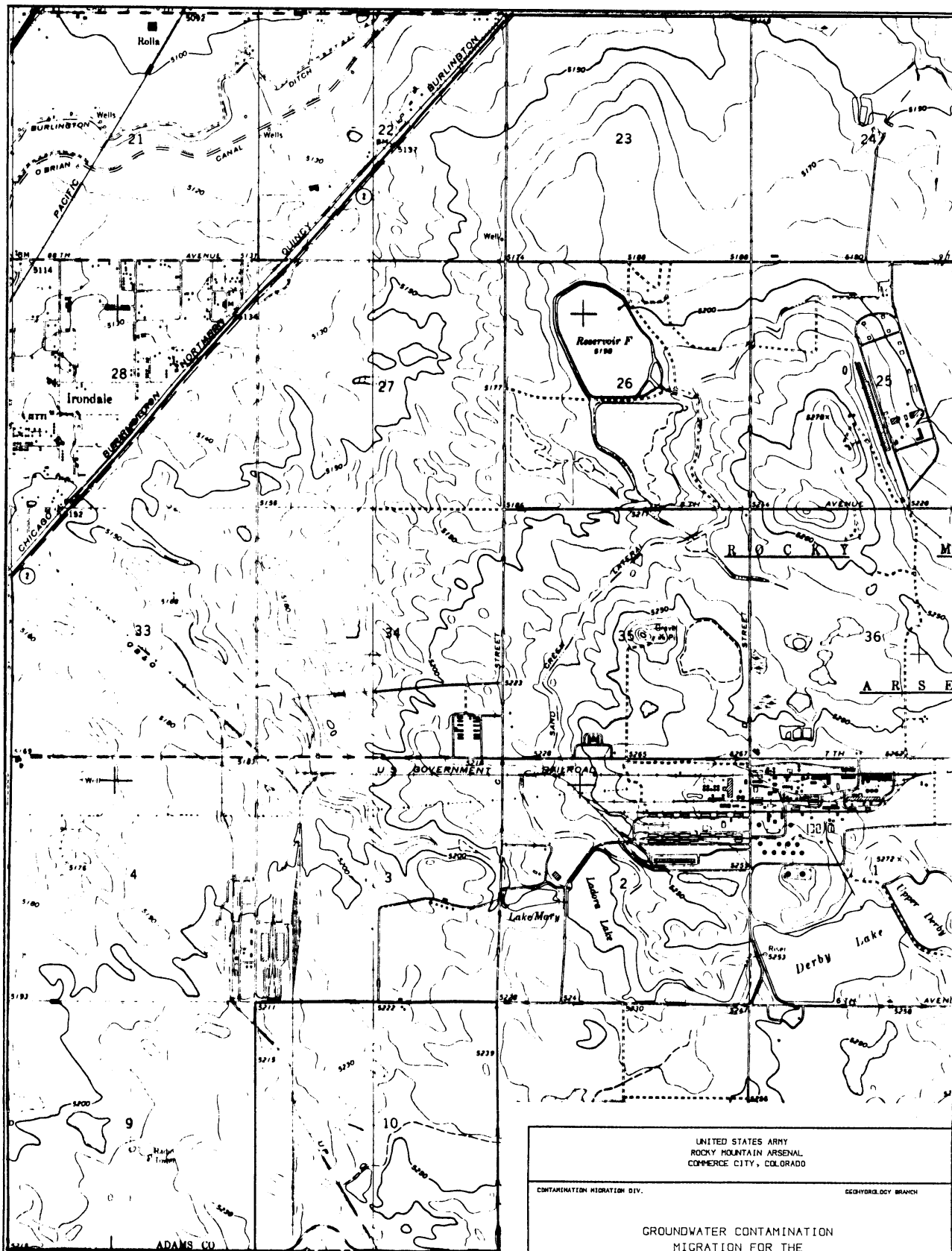

UNITED STATES ARMY
 ROCKY MOUNTAIN ARSENAL
 COMMERCE CITY, COLORADO

CONTAMINATION MIGRATION DIV. GEOHYDROLOGY BRANCH

GROUNDWATER CONTAMINATION
 MIGRATION FOR THE
 NORTHWEST AREA OF RMA

GROUND ELEVATION MAP

SCALE: As shown	APPROVED	DATE Oct 78
FIGURE 4		

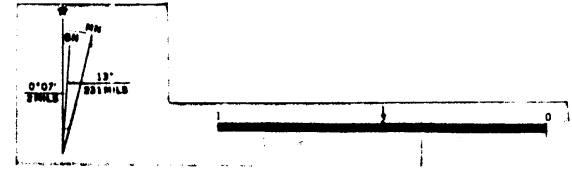

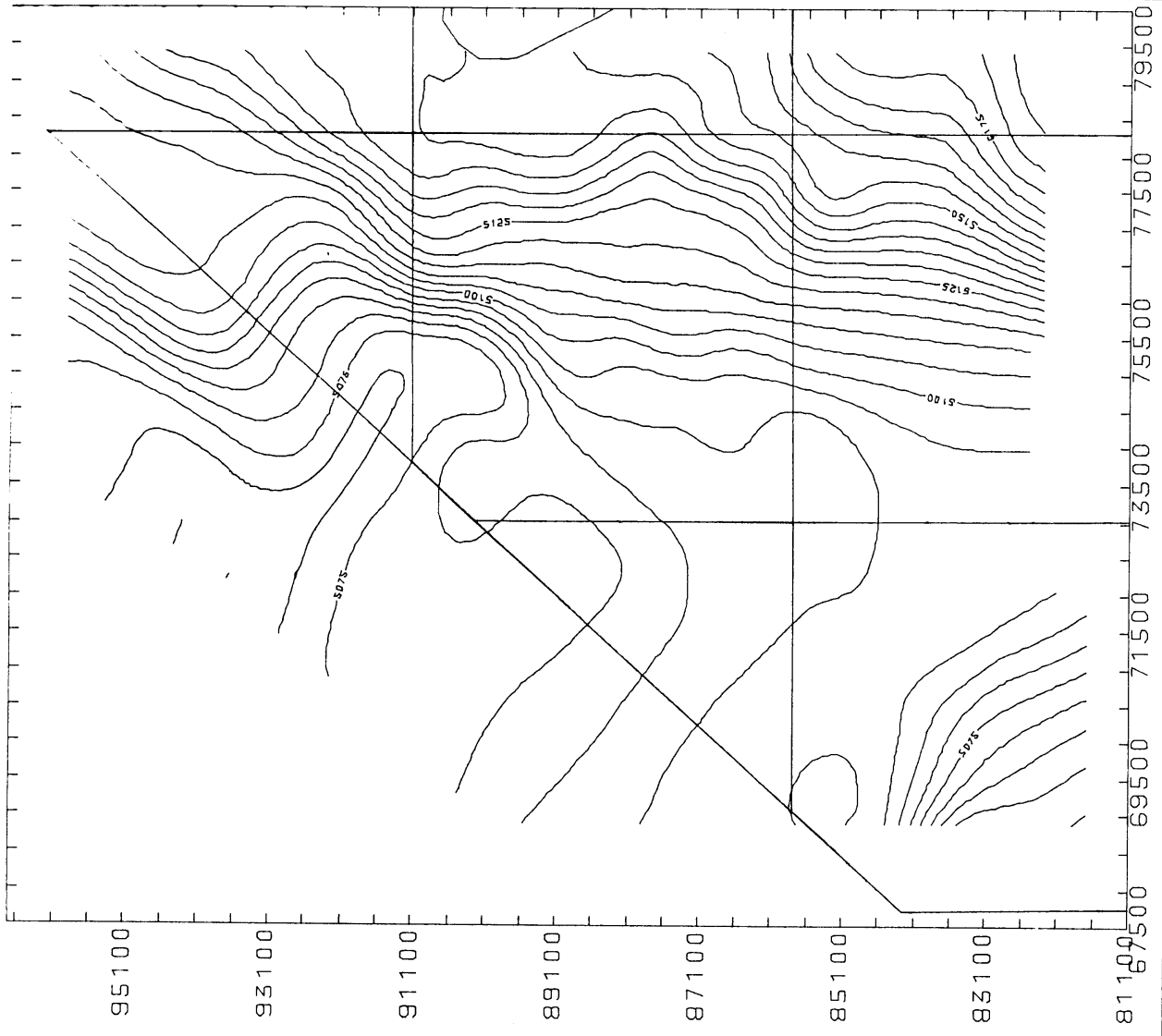

* NORTH-WEST QUADRANT STUDY AREA - BEDROCK
 PLOT No. 1 DATE 10/28/78 TIME 17.50.01

UNITED STATES ARMY ROCKY MOUNTAIN ARSENAL COMMERCE CITY, COLORADO		DATE Oct 78
CONTAMINATION MIGRATION DIV	GEOLOGY BRANCH	
GROUNDWATER CONTAMINATION MIGRATION FOR THE NORTHWEST AREA OF RMA BEDROCK ELEVATION MAP		
SCALE AS SHOWN	APPROVED	FIGURE 5
Contour Interval 5 Ft.		

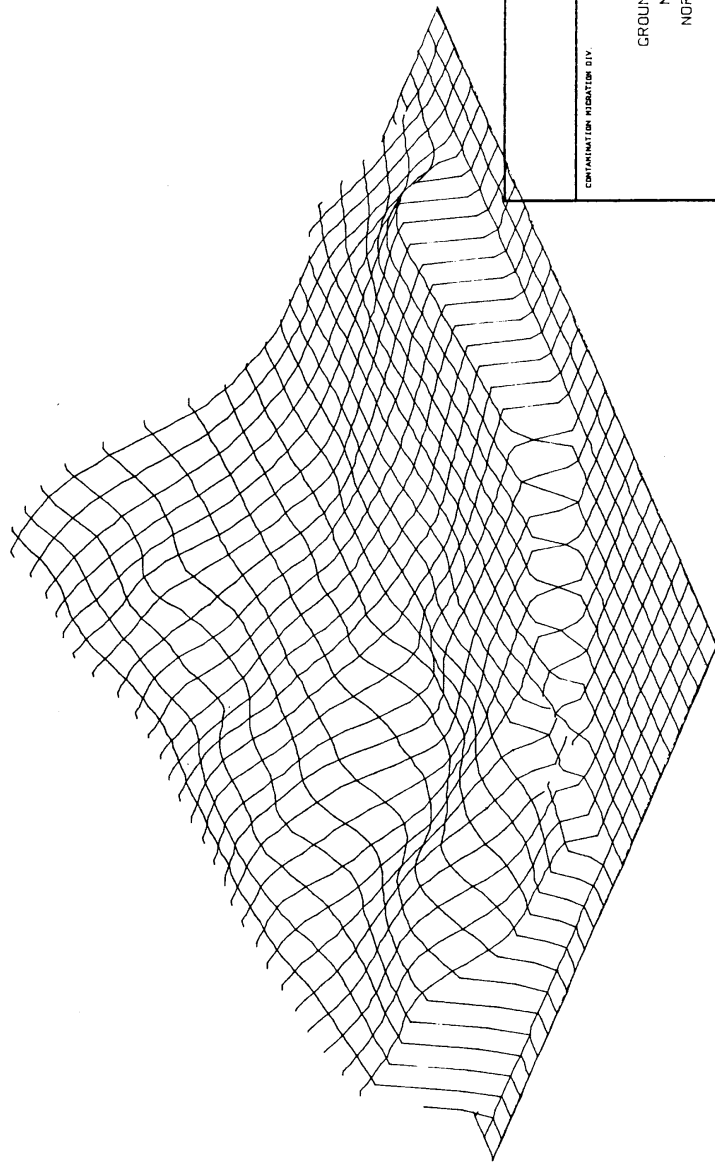

* NORTH-WEST QUADRANT STUDY AREA - BEDROCK
 PLOT NO. 4
 DATE 10/26/78
 TIME 17.48.50
 AZIM = -135.0
 ELEV = 25.0
 DIST = 250000

UNITED STATES ARMY
 ROCKY MOUNTAIN ARSENAL
 COPPER CITY, COLORADO

CONTAMINATION MIGRATION DIV.

GEOMORPHOLOGY BRANCH

GROUNDWATER CONTAMINATION
 MIGRATION FOR THE
 NORTHWEST AREA OF RMA

BEDROCK ELEV BLOCK DIAGRAM

SCALE:
AS SHOWN

APPROVED

DATE
Oct 78

FIGURE 6

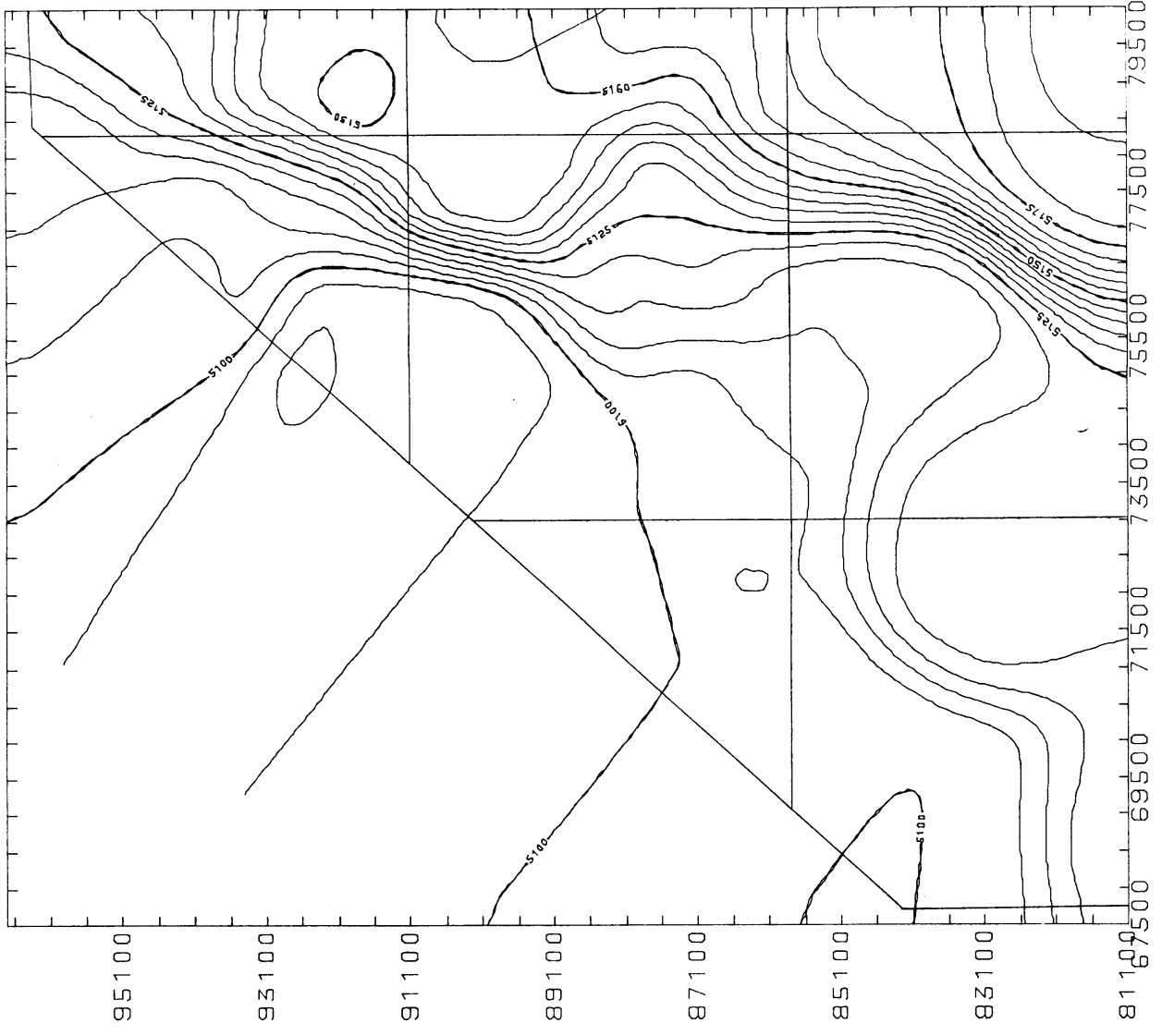

WATER LEVELS FOR NORTH-EAST QUADRANT STUDY AREA
 * PLOT NO. 1 DATE 10/31/78 TIME 17.27.44

UNITED STATES ARMY MISSISSIPPI VALLEY DISTRICT (ATTENTION: CIVIL ENGINEER)		GEOLOGICAL BRANCH	
GROUNDWATER CONTAMINATION INVESTIGATION FOR THE NORTHWEST AREA OF RMA			
GROUND WATER ELEVATION MAP			
CONSTRUCTION DIVISION	APPROVED	DATE	Oct 78
SCALE: AS SHOWN		Contour Interval 5 Ft.	
		PLACING	7

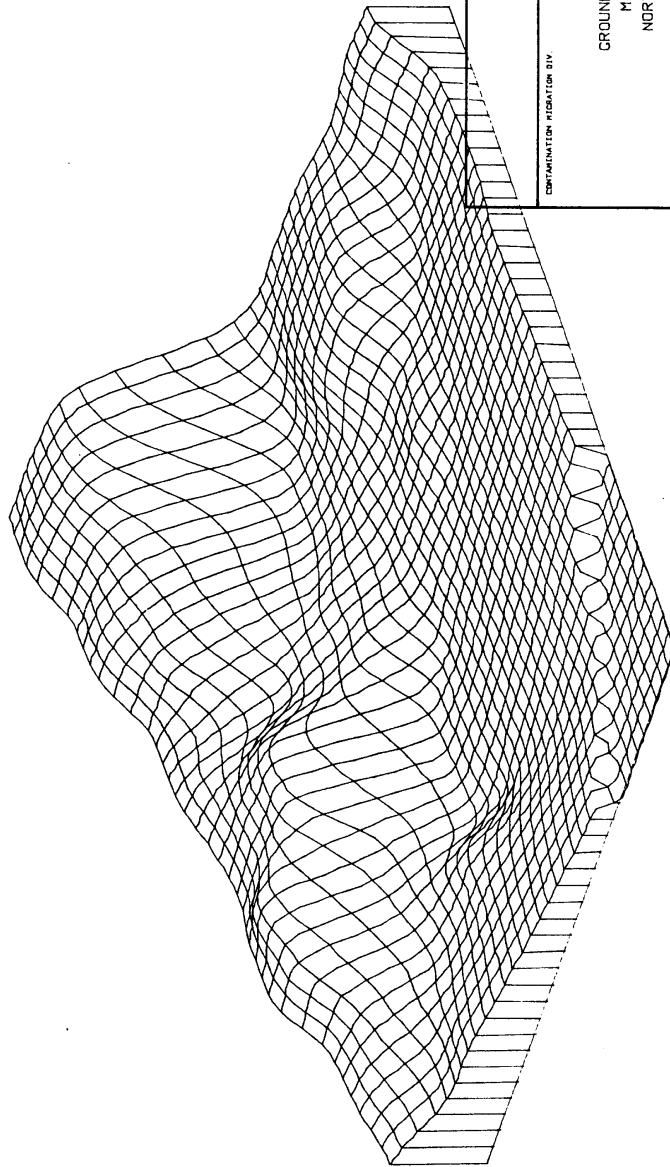

WATER LEVELS FOR NORTH-WEST QUADRANT STUDY AREA
 * PLOT NO. 2 DATE 10/31/78 TIME 17.28.42
 AZIM = -155.0 ELEV = 20.0 DIST = 250000

UNITED STATES ARMY
 ROCKY MOUNTAIN ARSENAL
 COMMERCE CITY, COLORADO

CONTAMINATION ABATEMENT DIV.

GEOMORPHOLOGY BRANCH

GROUNDWATER CONTAMINATION
 MIGRATION FOR THE
 NORTHWEST AREA OF RMA

GROUND WATER ELEV. BLOCK DIAGRAM

SCALE:
AS shown

APPROVED

DATE Oct 78

FIGURE 8

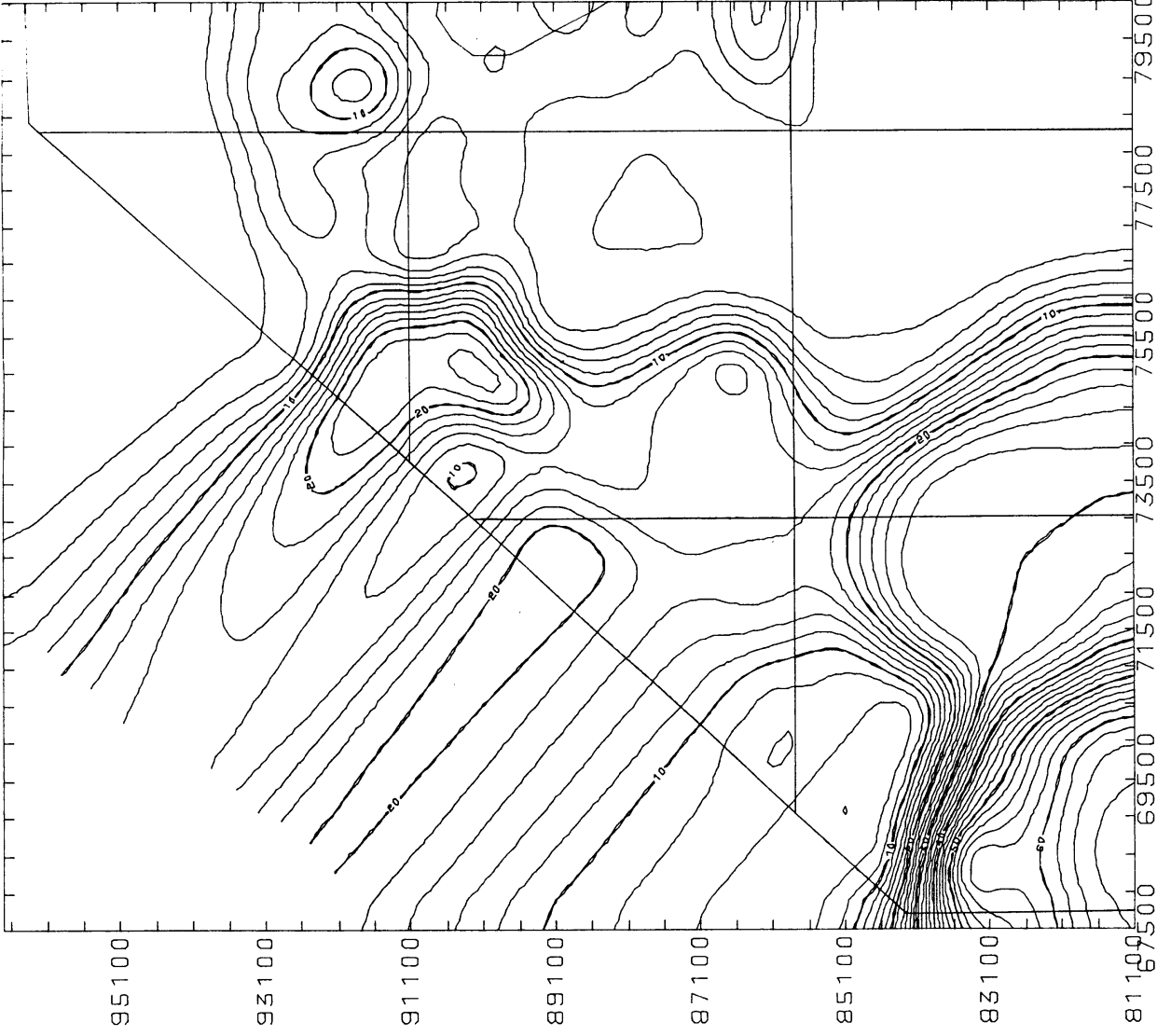

WATER LEVELS FOR NORTH-WEST QUADRANT STUDY AREA
 * PLOT NO. 1 DATE 11/01/78 TIME 12.09.56

UNITED STATES ARMY ROCKY MOUNTAIN ARSENAL COMMERCE CITY, COLORADO		GEOLOGICAL BRANCH	
CONTAMINATION MIGRATION DIV.		APPROVED	
GROUNDWATER CONTAMINATION MIGRATION FOR THE NORTHWEST AREA OF RMA		DATE Oct 78	
SATURATED THICKNESS MAP		FIGURE 9	
SCALE: AS SHOWN		Contour Interval 2 Ft	

* WATER LEVELS FOR NORTH-WEST QUADRANT STUDY AREA
 PLOT NO. 2
 DATE 11/01/78
 TIME 12.11.80
 AZIM = -155.0
 ELEV = 20.0
 DIST = 250000

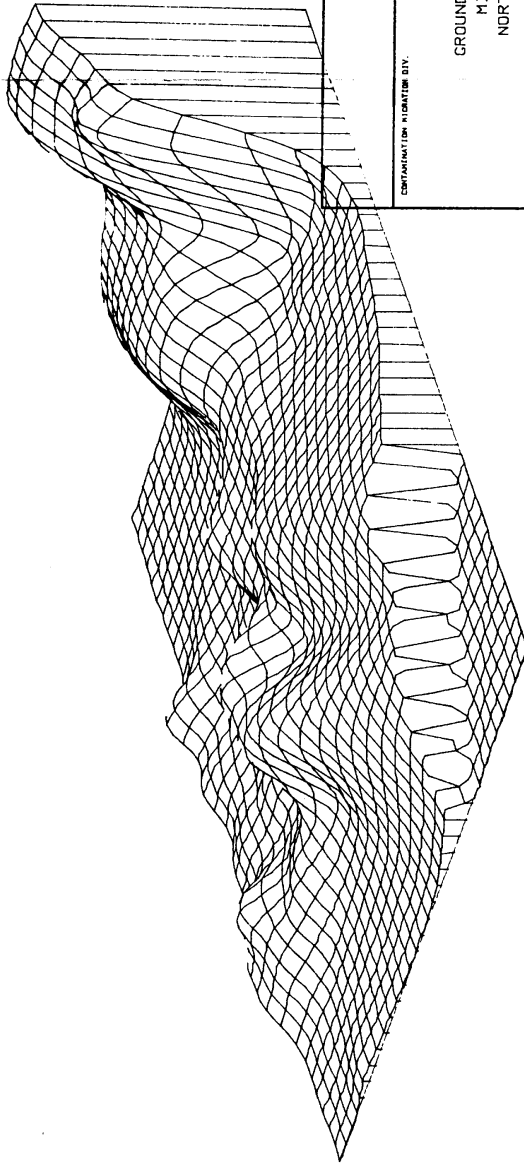

UNITED STATES ARMY
 ROCKY MOUNTAIN ARSENAL
 COMMERCE CITY, COLORADO

CONTAMINATION MIGRATION DIV. GEOHYDROLOGY BRANCH

GROUNDWATER CONTAMINATION
 MIGRATION FOR THE
 NORTHWEST AREA OF RMA

SATURATED THICKNESS BLOCK DIAGRAM

SCALE: AS SHOWN	APPROVED	DATE Oct 78
		FIGURE 10

5170
 5100
 5150
 5140
 5130
 5120
 5110
 5100
 5090
 5080
 5070
 5060
 5050
 5040
 5030
 5020

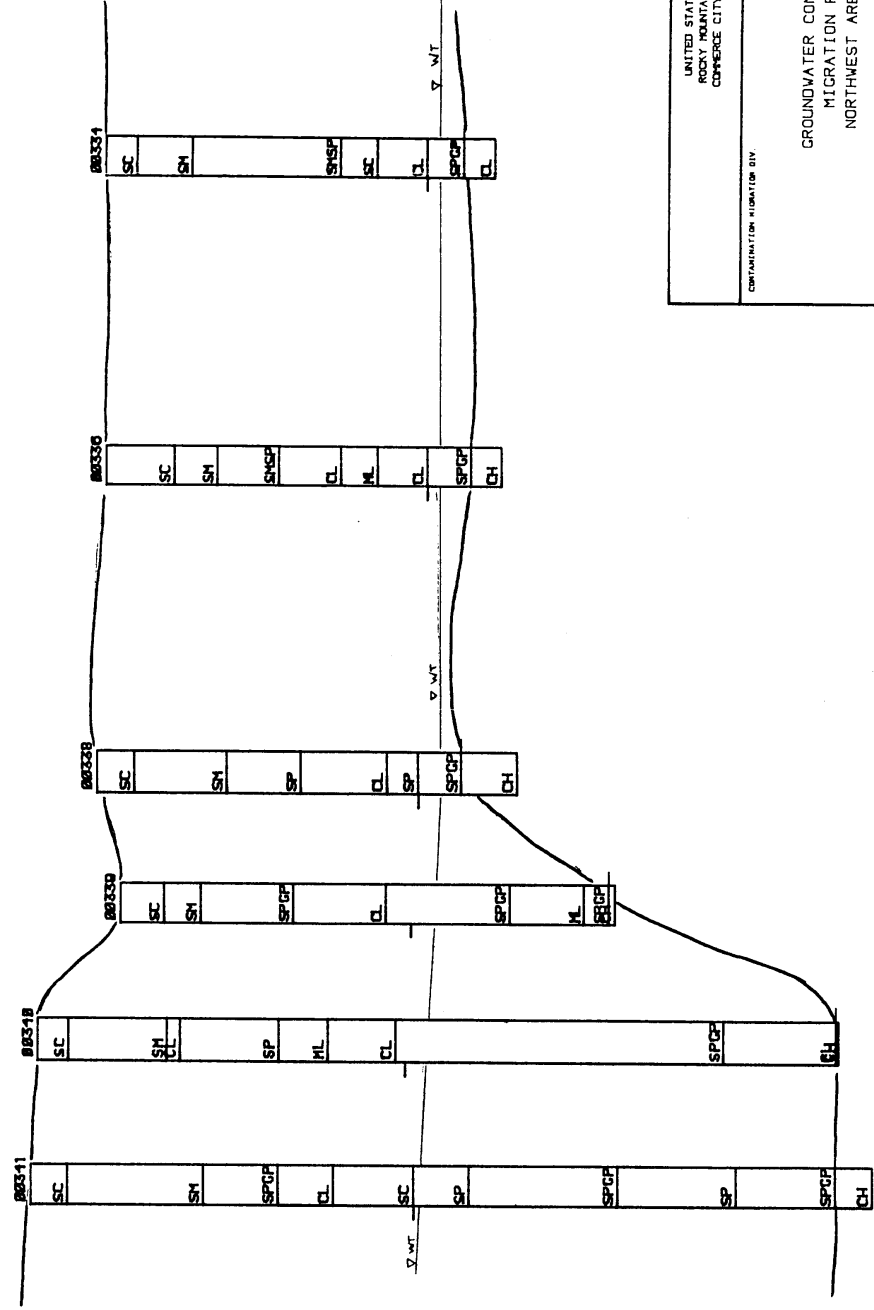

UNITED STATES ARMY ROCKY MOUNTAIN ARSENAL COMMERCE CITY, COLORADO		GEOLOGY BRANCH	
CONTAMINATION REMEDIATION DIV.		GROUNDWATER CONTAMINATION MIGRATION FOR THE NORTHWEST AREA OF RMA	
CROSS SECTION A-A' UNIT 1		APPROVED AS SHOWN	DATE Oct 78
		FIGURE 12	

5100
5150
5110
5120
5120
5110
5100
5000
5000

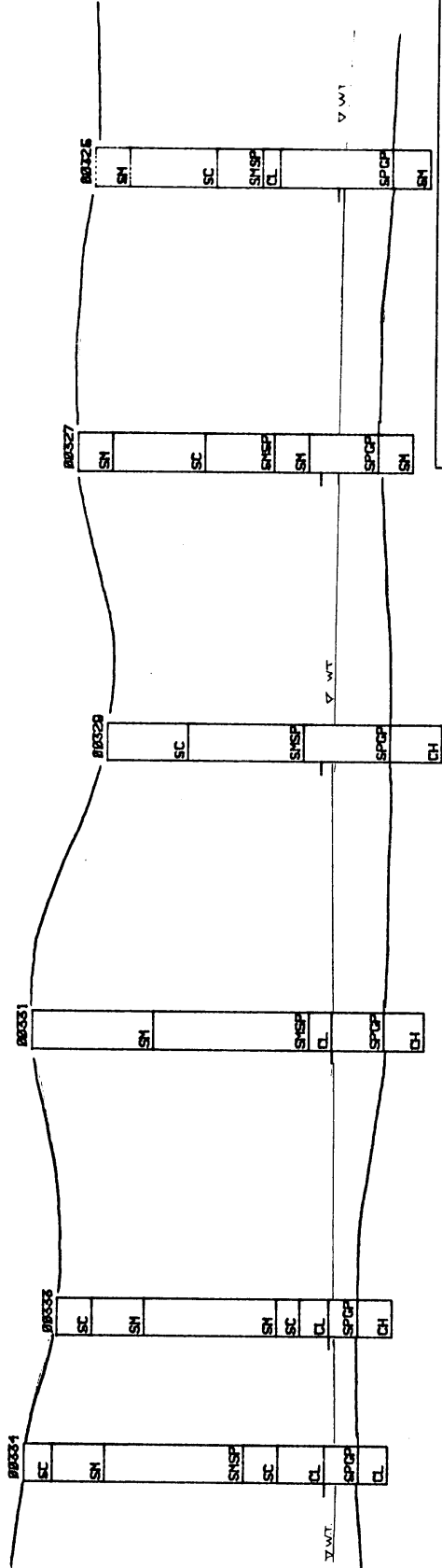

5000 1:100 FT.

UNITED STATES ARMY
ROCKY MOUNTAIN ARSENAL
COMMERCE CITY, COLORADO

CONTAMINATION MONITORING DIV. GEOCHEMISTRY BRANCH

GROUNDWATER CONTAMINATION
MIGRATION FOR THE
NORTHWEST AREA OF RMA

CROSS SECTION A-A' UNIT 2

SCALE AS SHOWN	APPROVED	DATE Oct 78
-------------------	----------	----------------

FIGURE 13

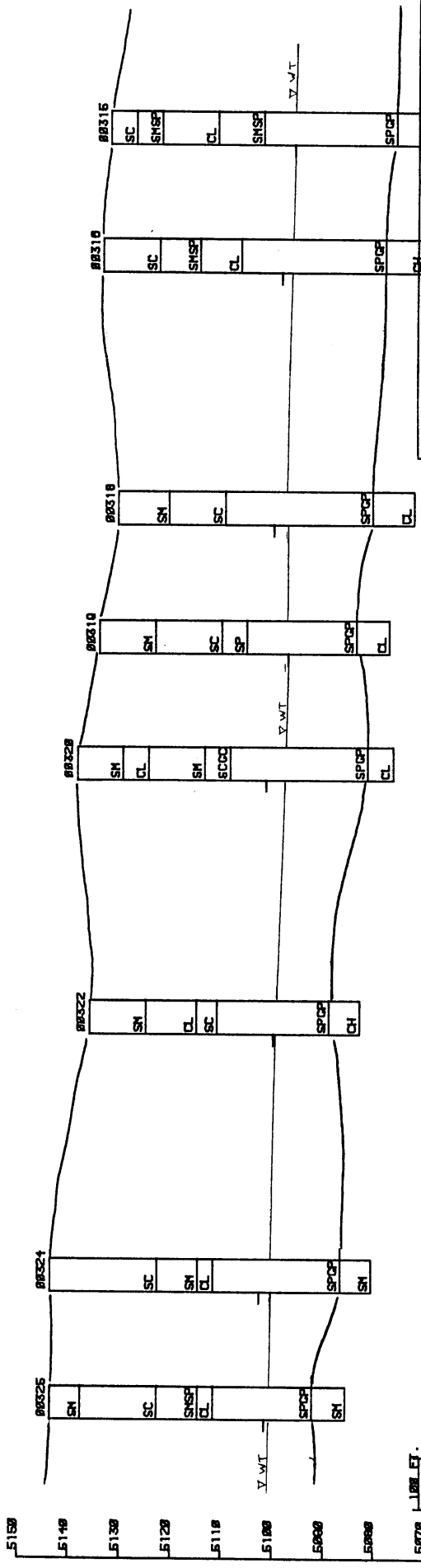

UNITED STATES ARMY
 CORP. OF ENGINEERS
 CONFERENCE CITY, COLORADO

CONTAMINATION IDENTIFICATION DIV.
 CENTRAL/CITY BRANCH

GROUNDWATER CONTAMINATION
 MIGRATION FOR THE
 NORTHWEST AREA OF RMA
 CROSS SECTION A-A' UNIT 3

DATE: 10/78
 APPROVED: [Signature]
 FIGURE 14

5149
 5130
 5120
 5110
 5100
 5000
 5050
 5070
 5000 1.00 FT.

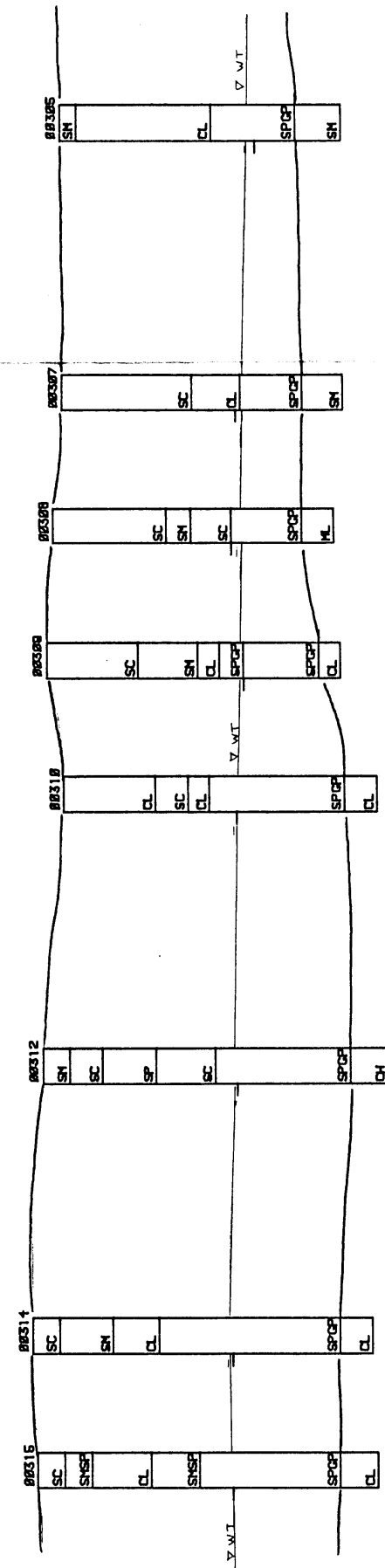

CONTAMINATION MONITORING DIV.		SCHEMATIC BRANCH	
UNITED STATES ARMY ROCKY MOUNTAIN ARSENAL COMMERCE CITY, COLORADO			
GROUNDWATER CONTAMINATION MIGRATION FOR THE NORTHWEST AREA OF RNA			
CROSS SECTION A-A, UNIT 4			
DATE	APPROVED	FIGURE 15	
Oct 78			

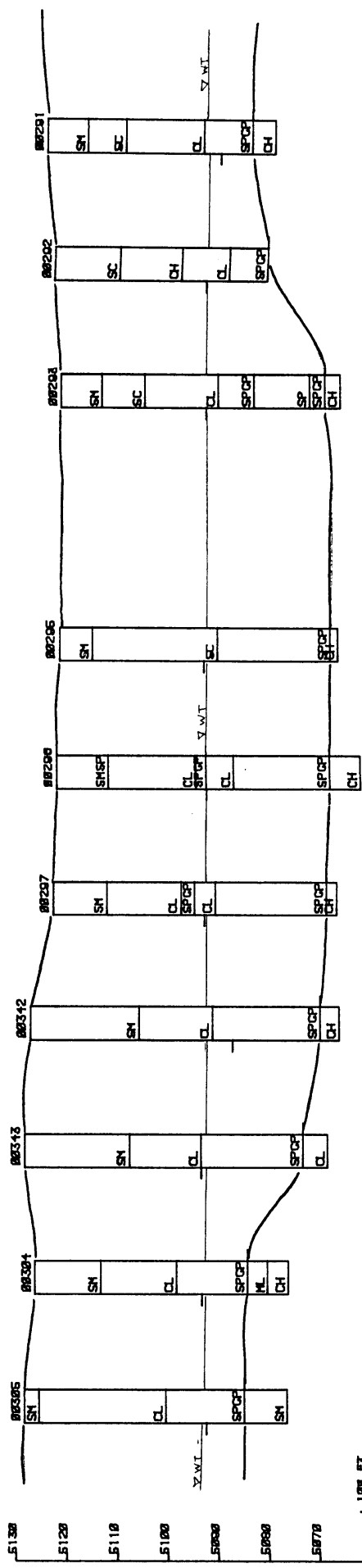

UNITED STATES ARMY
 ROCKY MOUNTAIN ARSENAL
 COFFEE CITY, COLORADO

CONTAMINATION MONITORING DIV.

GROUNDWATER CONTAMINATION
 MIGRATION FOR THE
 NORTHWEST AREA OF RMA

CROSS SECTION A-A' UNIT 5

DATE: Oct 78

FIGURE 16

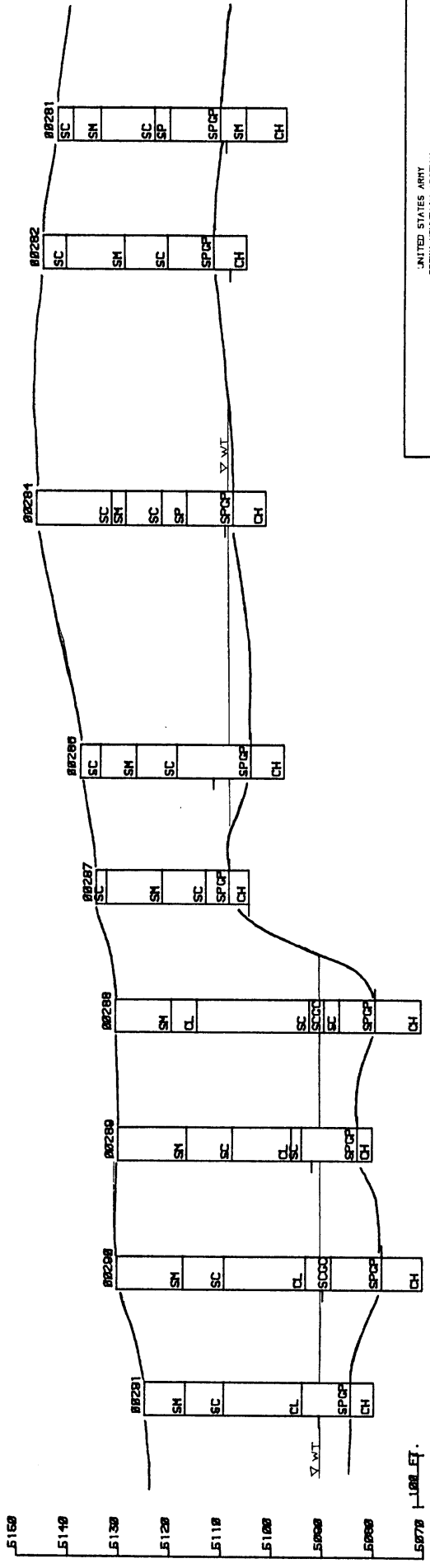

UNITED STATES ARMY
 ROCKY MOUNTAIN ARSENAL
 COMMERCE CITY, COLORADO

CONTAMINATION INVESTIGATION DIV. GEOLOGICAL BRANCH

GROUNDWATER CONTAMINATION
 MIGRATION FOR THE
 NORTHWEST AREA OF RMA

CROSS SECTION A-A' UNIT 6

SCALE: AS SHOWN APPROVED DATE: Oct 78

FIGURE 17

5150
5140
5130
5120
5110
5100
5000 1.000 FT.

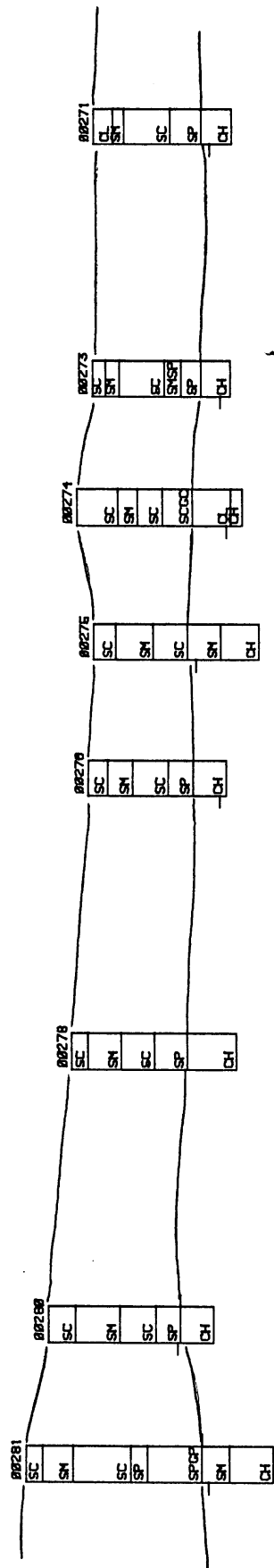

UNITED STATES ARMY
ROCKY MOUNTAIN ARSENAL
CORNER CITY, COLORADO

CONTAMINATION MIGRATION DIV. SCIENTIFIC BRANCH

GROUNDWATER CONTAMINATION
MIGRATION FOR THE
NORTHWEST AREA OF RMA

CROSS SECTION A-A' UNIT 7

SCALE AS SHOWN	APPROVED	DATE
		Oct 78

FIGURE 18

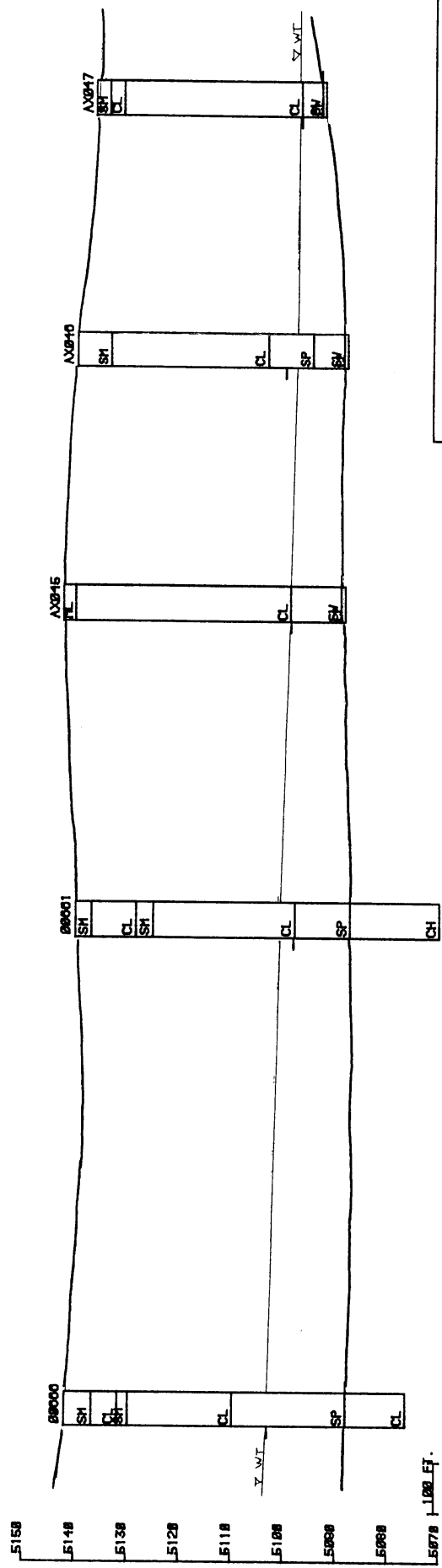

UNITED STATES ARMY
 ROCKY MOUNTAIN ARSENAL
 COMMERCE CITY, COLORADO

CONTAMINATION RESOLUTION DIV. GEOLOGICAL BRANCH

GROUNDWATER CONTAMINATION
 MIGRATION FOR THE
 NORTHWEST AREA OF RMA

CROSS SECTION B-B', UNIT 1

SCALE: AS SHOWN	APPROVED	DATE Oct 78
FIGURE 19		

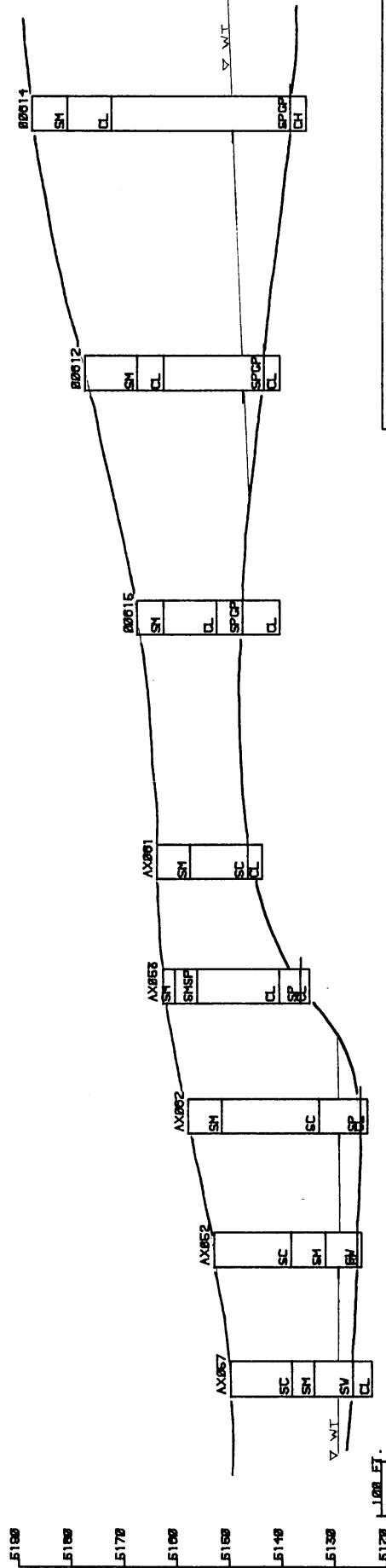

UNITED STATES ARMY
 ROCKY MOUNTAIN ARSENAL
 COMMERCE CITY, COLORADO

CONTAMINATION MIGRATION DIV. GEOHYDROLOGY BRANCH

GROUNDWATER CONTAMINATION
 MIGRATION FOR THE
 NORTHWEST AREA OF RMA

CROSS SECTION B-B' UNIT 3

SCALE: AS SHOWN	APPROVED	DATE Oct 78
		FIGURE 21

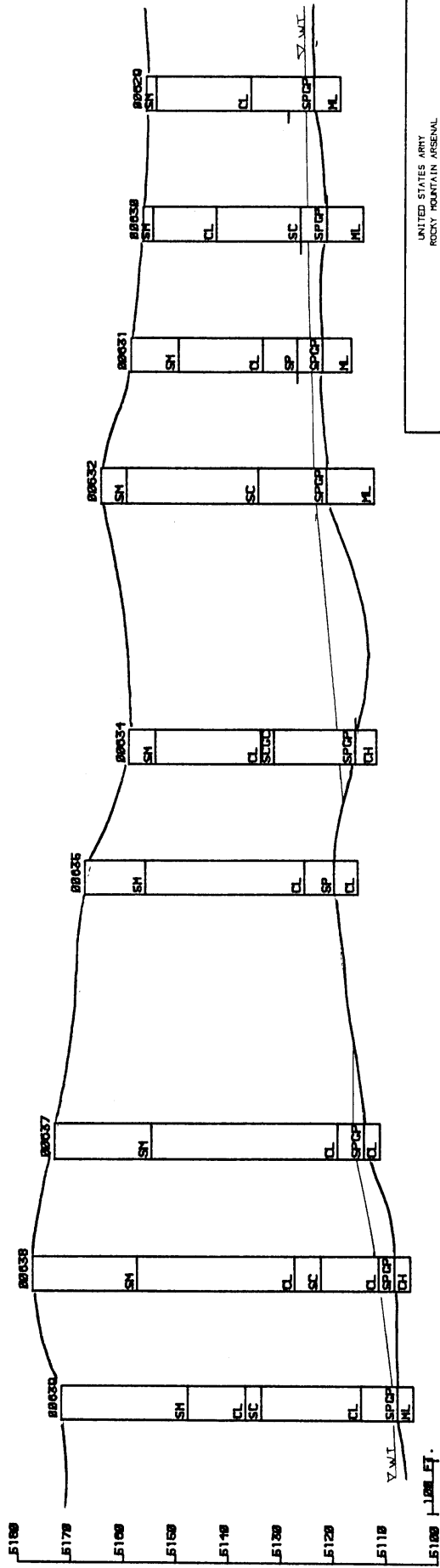

UNITED STATES ARMY
 ROCKY MOUNTAIN ARSENAL
 COFFEE CITY, COLORADO

GROUNDWATER CONTAMINATION
 MIGRATION FOR THE
 NORTHWEST AREA OF RMA
 CROSS SECTION C-C' UNIT 1

CONTAMINATION INDICATION DIV. GEOLOGICAL BANDS

SCALE AS SHOWN	APPROVED	DATE OCT. 78
-------------------	----------	-----------------

FIGURE 22

51169
 51170
 51180
 51182
 51140
 51180
 51120
 51110 1-100 LF

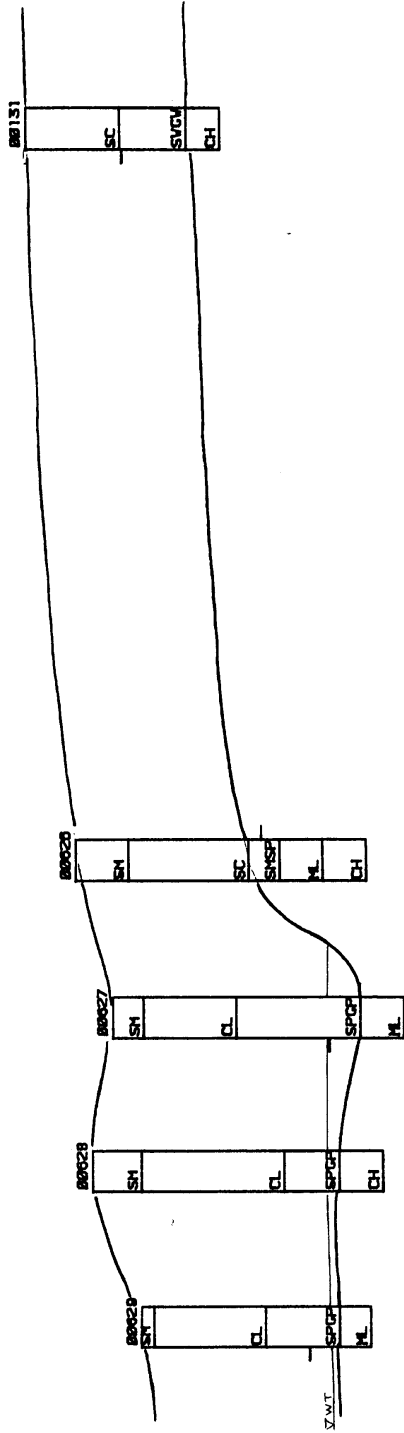

UNITED STATES ARMY
 ROCKY MOUNTAIN ARSENAL
 COMMERCE CITY, COLORADO

CONTAMINATION MIGRATION DIV. GEOHYDROLOGY BRANCH

GROUNDWATER CONTAMINATION
 MIGRATION FOR THE
 NORTHWEST AREA OF RMA

CROSS SECTION C-C' UNIT 2

SCALE: As shown APPROVED: DATE: Oct 78

FIGURE 23

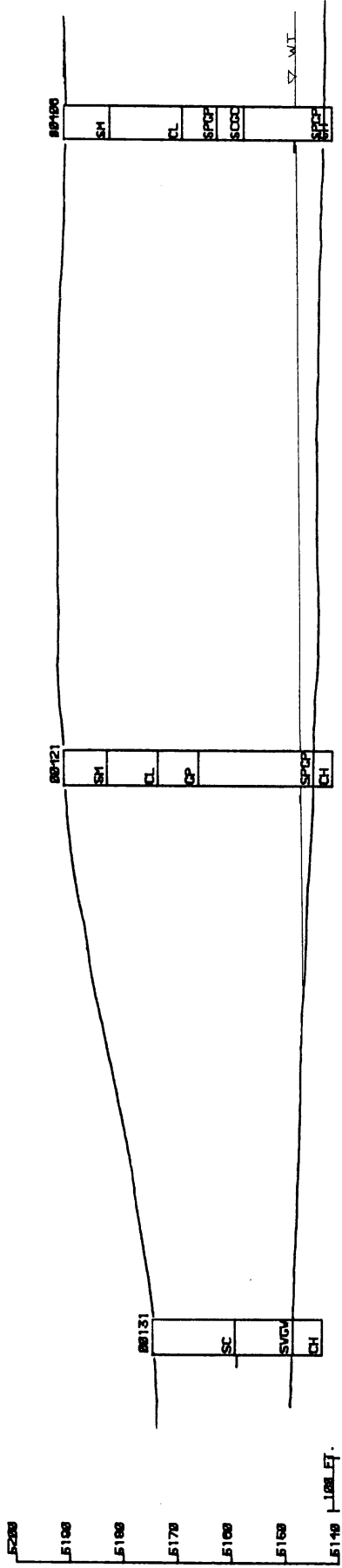

UNITED STATES ARMY ROCKY MOUNTAIN ARSENAL CONNECCT CITY, COLORADO		GROUNDWATER CONTAMINATION MIGRATION FOR THE NORTHWEST AREA OF RMA	
CONTAMINATION ABATEMENT DIV.		GSH/ROBERTS/RYAN	
SCALE: AS SHOWN		APPROVED	DATE Oct 78
		FIGURE 24	

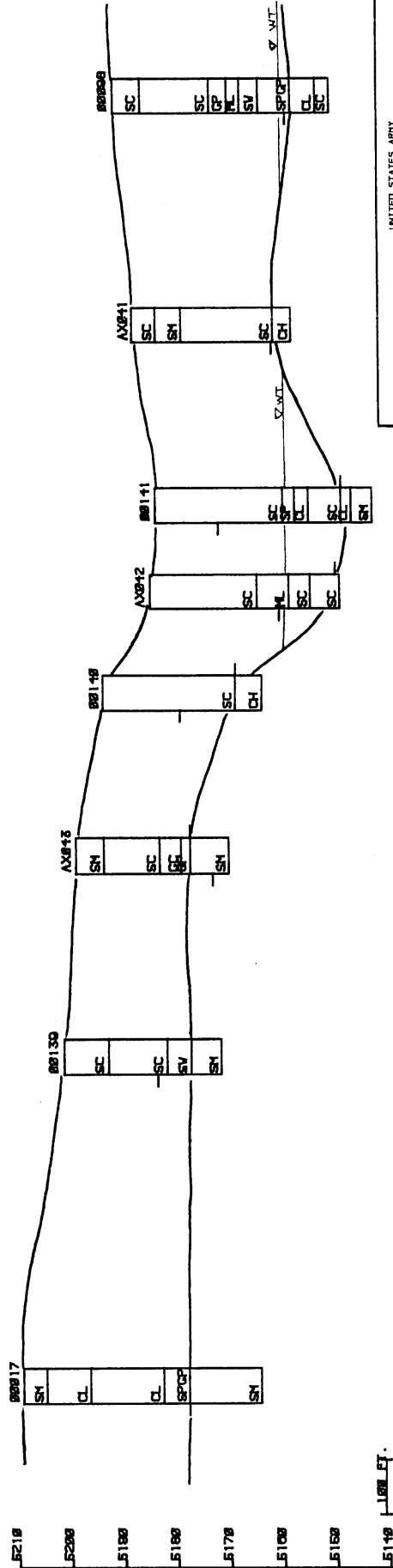

5140 1000 FT.

UNITED STATES ARMY
 ROCKY MOUNTAIN ARSENAL
 COMMERCE CITY, COLORADO

CONTAMINATION MIGRATION DIV. GEOHYDROLOGY BRANCH

GROUNDWATER CONTAMINATION
 MIGRATION FOR THE
 NORTHWEST AREA OF RMA

CROSS SECTION D-D' UNIT 1

SCALE: AS SHOWN APPROVED DATE: OCT. 78

FIGURE 25

5210
 5200
 5180
 5160
 5170
 5100
 5150
 5140 1100 FT.

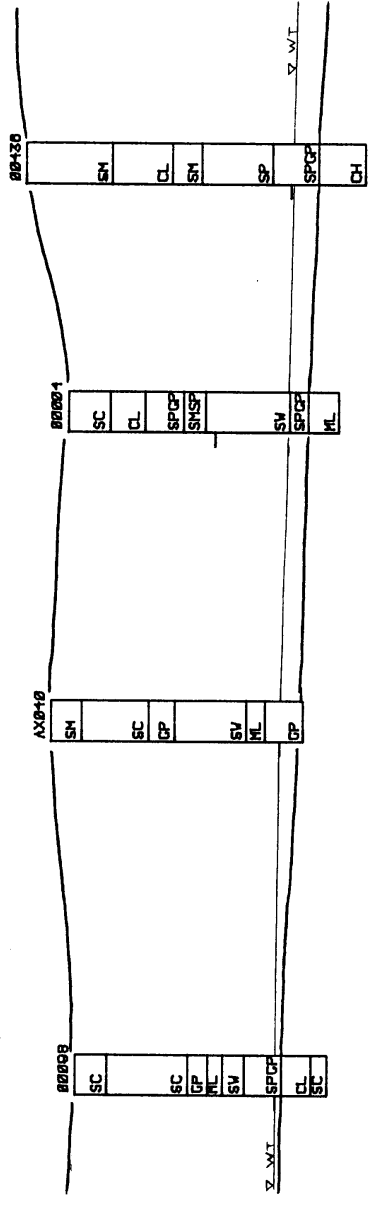

UNITED STATES ARMY
 ROCKY MOUNTAIN ARSENAL
 COMMERCE CITY, COLORADO

CONTAMINATION MIGRATION DIV.
 SCHEMATIC BRANCH

GROUNDWATER CONTAMINATION
 MIGRATION FOR THE
 NORTHWEST AREA OF RMA
 CROSS SECTION D-D', UNIT 2

SCALE: AS shown
 APPROVED: [Signature]
 DATE: Oct 78

FIGURE 26

5200
 5100
 5180
 5170
 5108
 5150
 5140
 5130
 5120
 5110
 5100
 5000
 5080
 5070
 5000

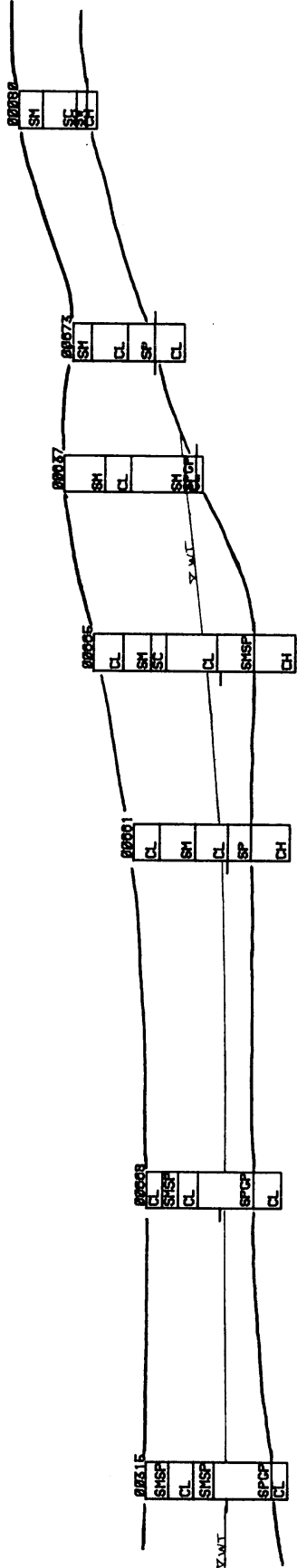

UNITED STATES ARMY
 ROCKY MOUNTAIN ARSENAL
 COFFEE CITY, COLORADO

CONTAMINATION REMEDIATION DIV.

GROUNDWATER CONTAMINATION
 MIGRATION FOR THE
 NORTHWEST AREA OF RMA
 CROSS SECTION W-W'

SCALE: HOF 1" = 500'	APPROVED	DATE Oct 7/81
FIGURE 27		

5200
5100
5180
5170
5100
5150
5140
5130
5120
5110
5100
5000
5080
5070
5060

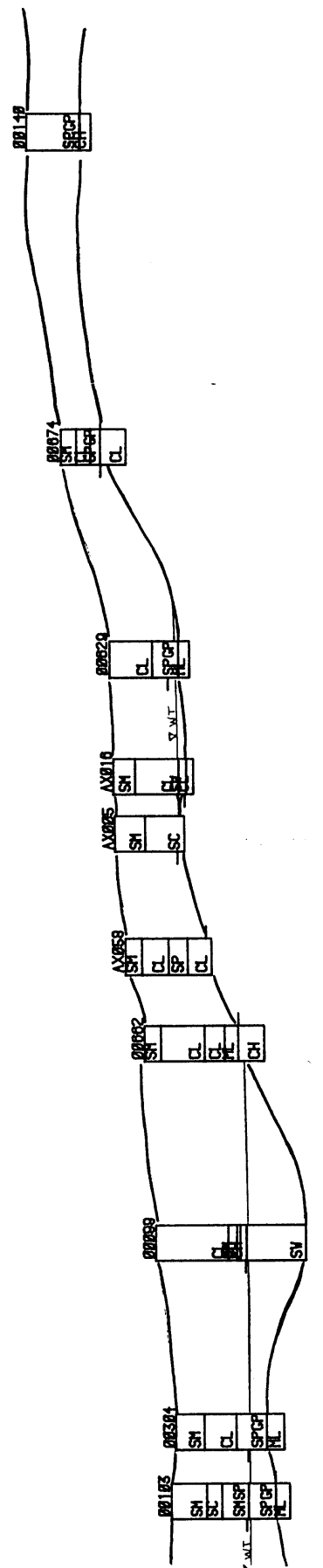

UNITED STATES ARMY
ROCKY MOUNTAIN ARSENAL
COMMERCE CITY, COLORADO

CONTAMINATION MONITORING DIV.

COMBINATIONARY MAP

GROUNDWATER CONTAMINATION
MIGRATION FOR THE
NORTHWEST AREA OF RMA
CROSS SECTION X-X'

SCALE: HOR. 1" = 600'	APPROVED	DATE Oct 78
--------------------------	----------	----------------

FIGURE 28

E2000
 E1900
 E1800
 E1700
 E1600
 E1500
 E1400
 E1300
 E1200
 E1100
 E9900
 E9800
 E9700
 E9600

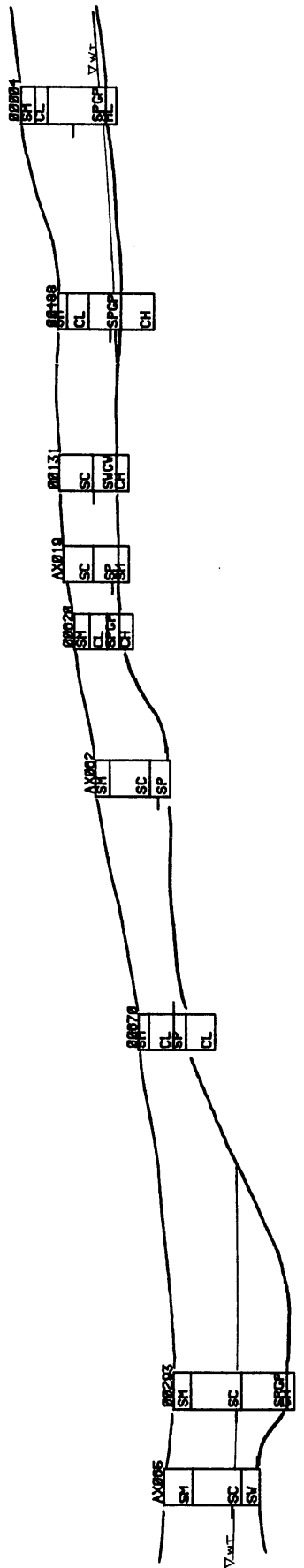

UNITED STATES ARMY ROCKY MOUNTAIN ARSENAL COMMERCE CITY, COLORADO		GEOBIOLOGY BRANCH	
CONTAMINATION MIGRATION DIV.		GROUNDWATER CONTAMINATION MIGRATION FOR THE NORTHWEST AREA OF RMA CROSS SECTION Y-Y'	
SCALE: HOR: 1" = 500'	APPROVED	DATE Oct 78	FIGURE 29

5200
5100
5180
5170
5100
5150
5148
5130
5120
5110
5100
5000

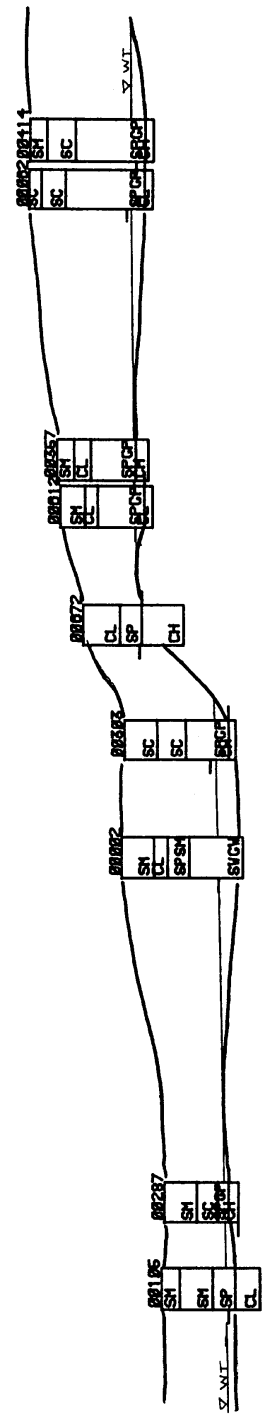

UNITED STATES ARMY ROCKY MOUNTAIN ARSENAL COMMERCE CITY, COLORADO		GEOLOGICAL BRANCH	
CONTAMINATION ABIGATION DIV.		GROUNDWATER CONTAMINATION MIGRATION FOR THE NORTHWEST AREA OF RNA CROSS SECTION Z-Z'	
SCALE Hor. 1" = 500'	APPROVED	DATE Oct 78	FIGURE 30

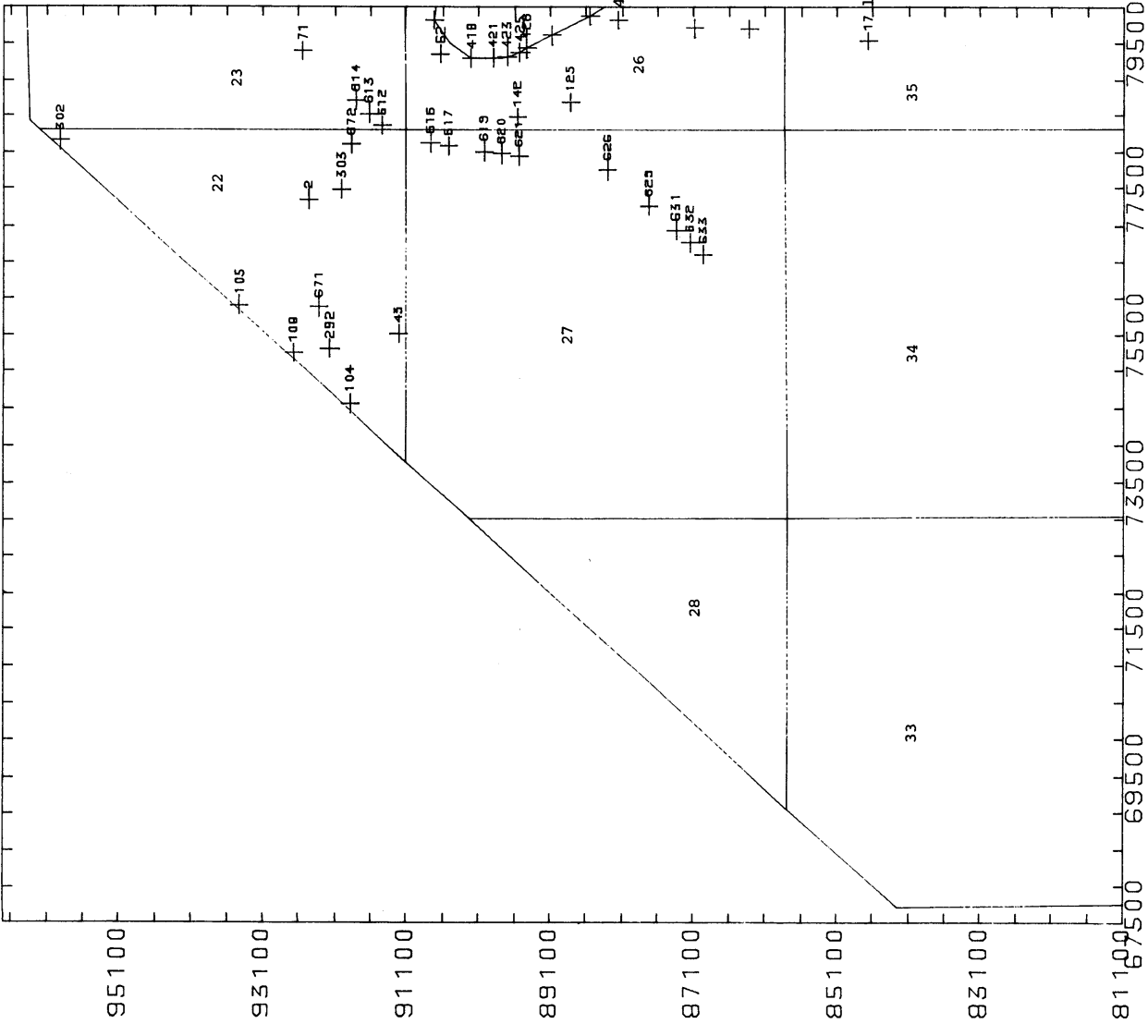

FIGURE 31. LOCATION OF WELLS IN THE NORTHWEST AREA OF RMA CONTAINING SIGNIFICANT LEVELS OF FLUORIDE
SCALE: As shown

LOCATIONS OF SIGNIFICANT FLUORIDE
 * PLOT NO. 1
 DATE 11/03/78
 TIME 10:58:27

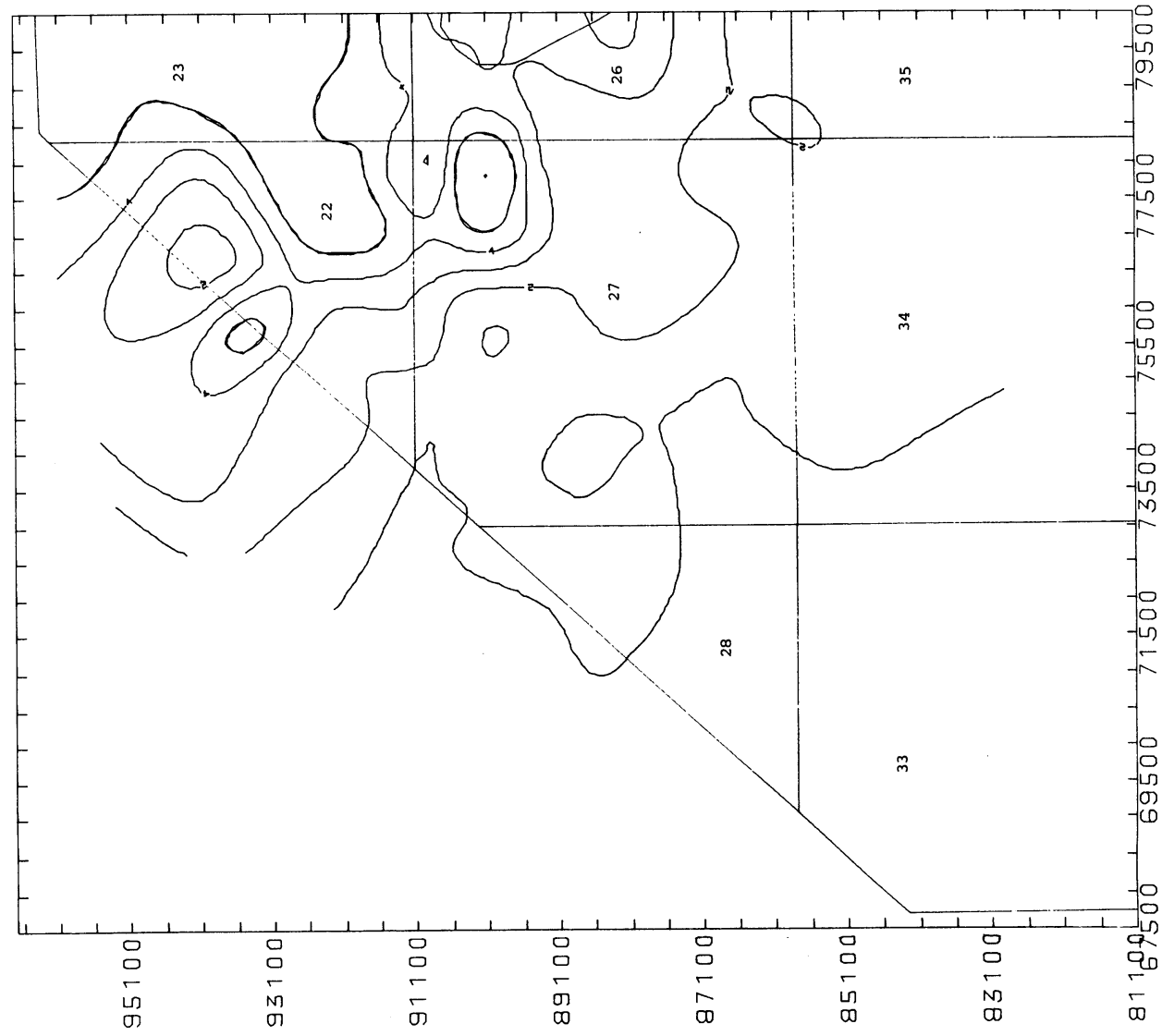

FIGURE 32. DISTRIBUTION OF FLUORIDE
IN THE NORTHWEST AREA OF RMA.

SCALE: As shown
CONTOUR INTERVAL: 1 ppm

* FLUORIDE DISTRIBUTION
PLOT NO. 1
DATE 11/03/78
TIME 10:38:54

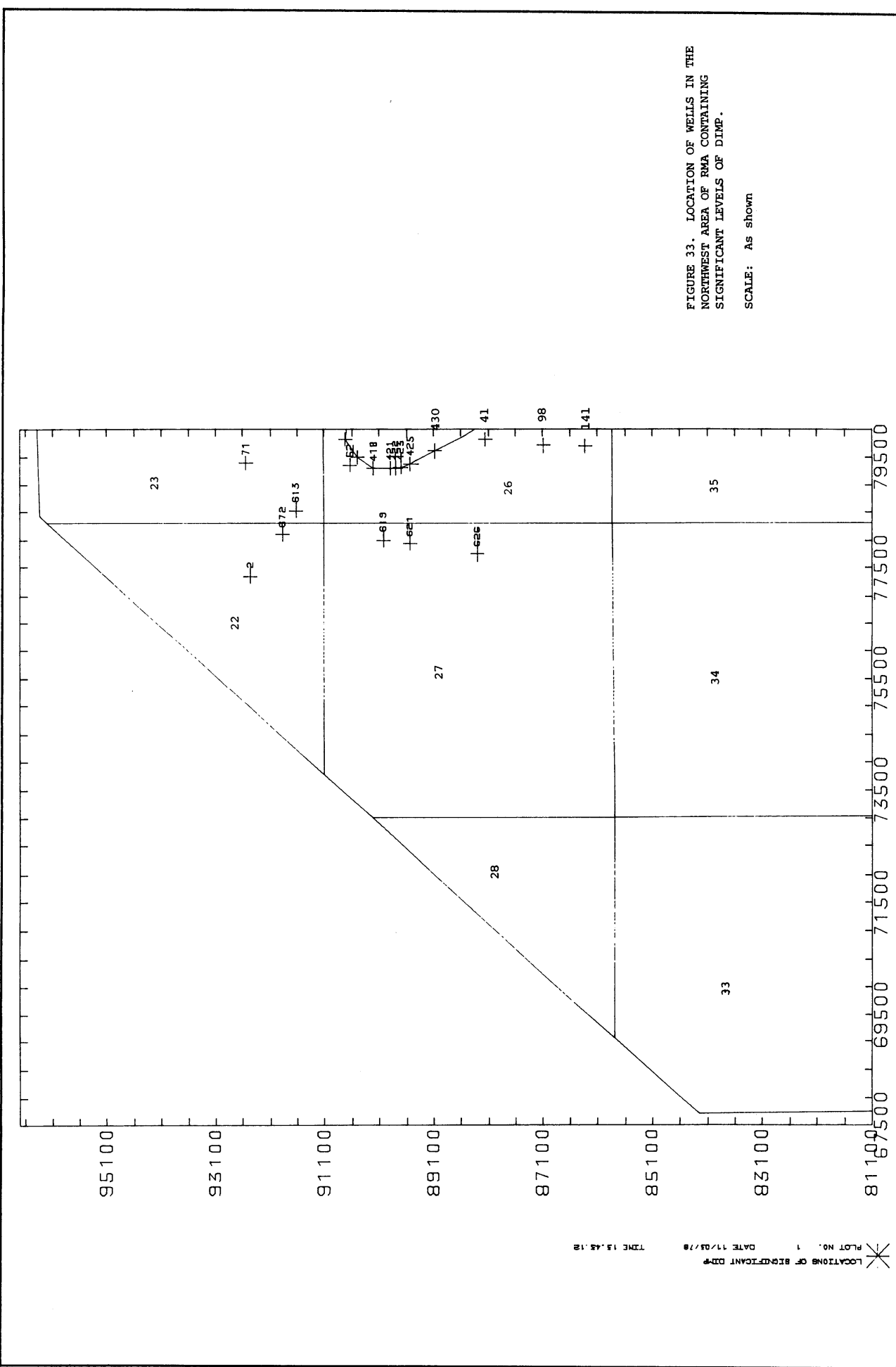

FIGURE 33. LOCATION OF WELLS IN THE NORTHWEST AREA OF RMA CONTAINING SIGNIFICANT LEVELS OF DIMP. SCALE: As shown

LOCATIONS OF SIGNIFICANT DIMP
 PLOT NO. 1
 DATE 11/23/78
 TIME 15.45.12

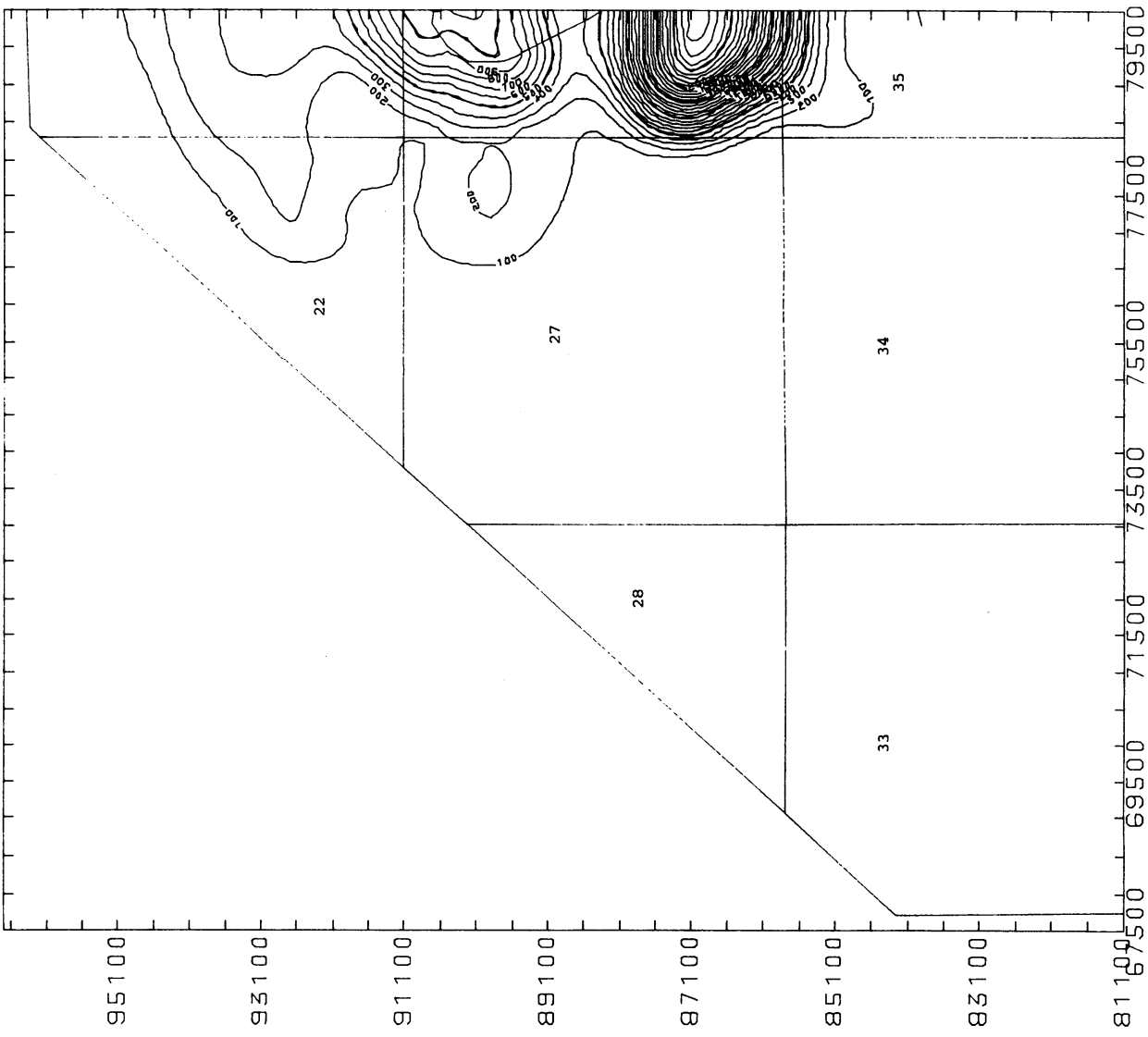

FIGURE 34. DISTRIBUTION OF DIMP
IN THE NORTHWEST AREA OF RMA.

SCALE: As shown

CONTOUR INTERVAL: 100 ppb

* DIMP DISTRIBUTION
 PLOT NO. 1
 DATE 11/23/78 TIME 17.19.54

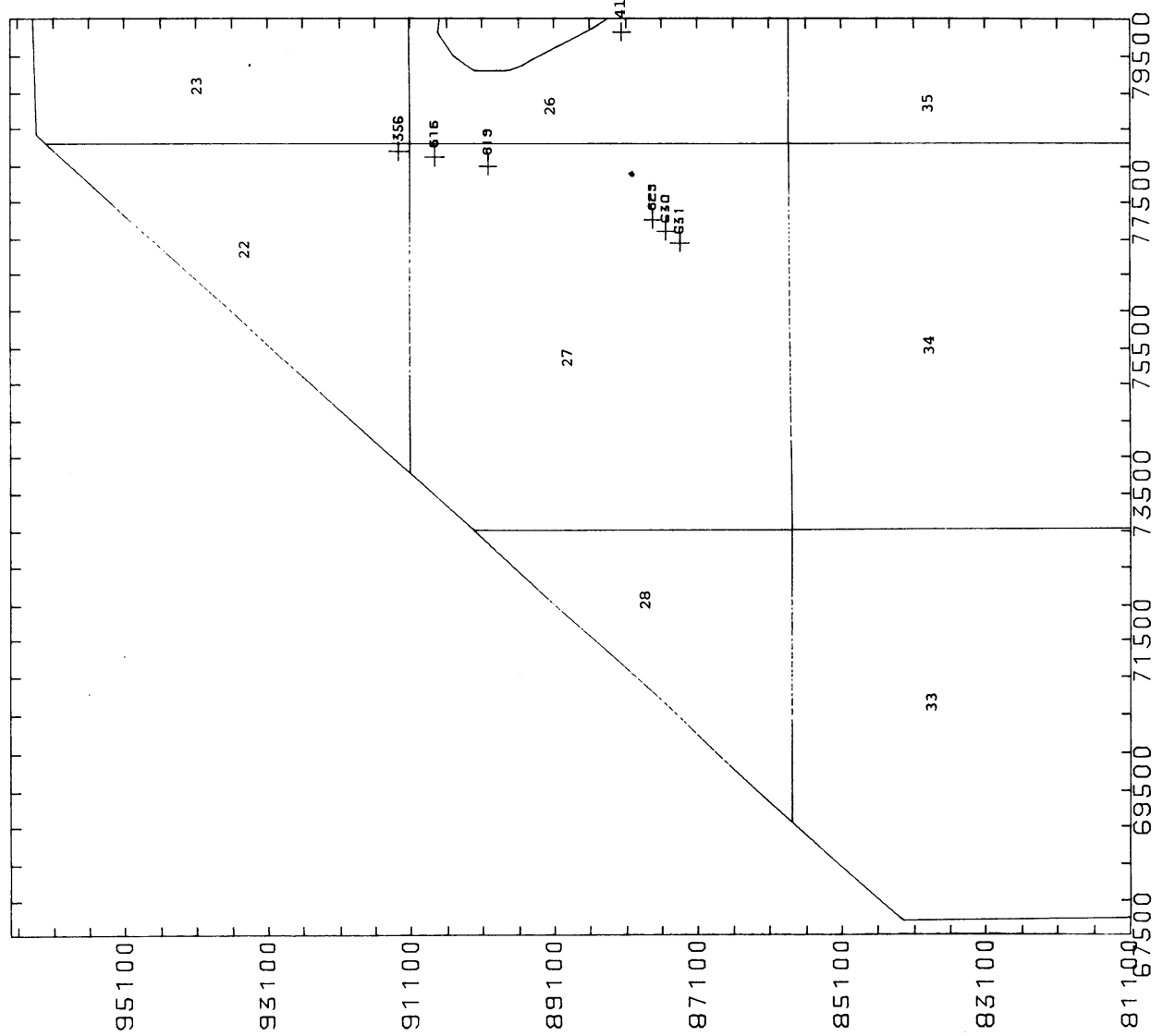

FIGURE 35. LOCATION OF WELLS IN THE NORTHWEST AREA OF RMA IN WHICH DCPD WAS DETECTED.
SCALE: AS SHOWN

LOCATIONS OF DETECTABLE DCPD
 * PLOT NO. 1 DATE 11/23/78 TIME 15.28.88

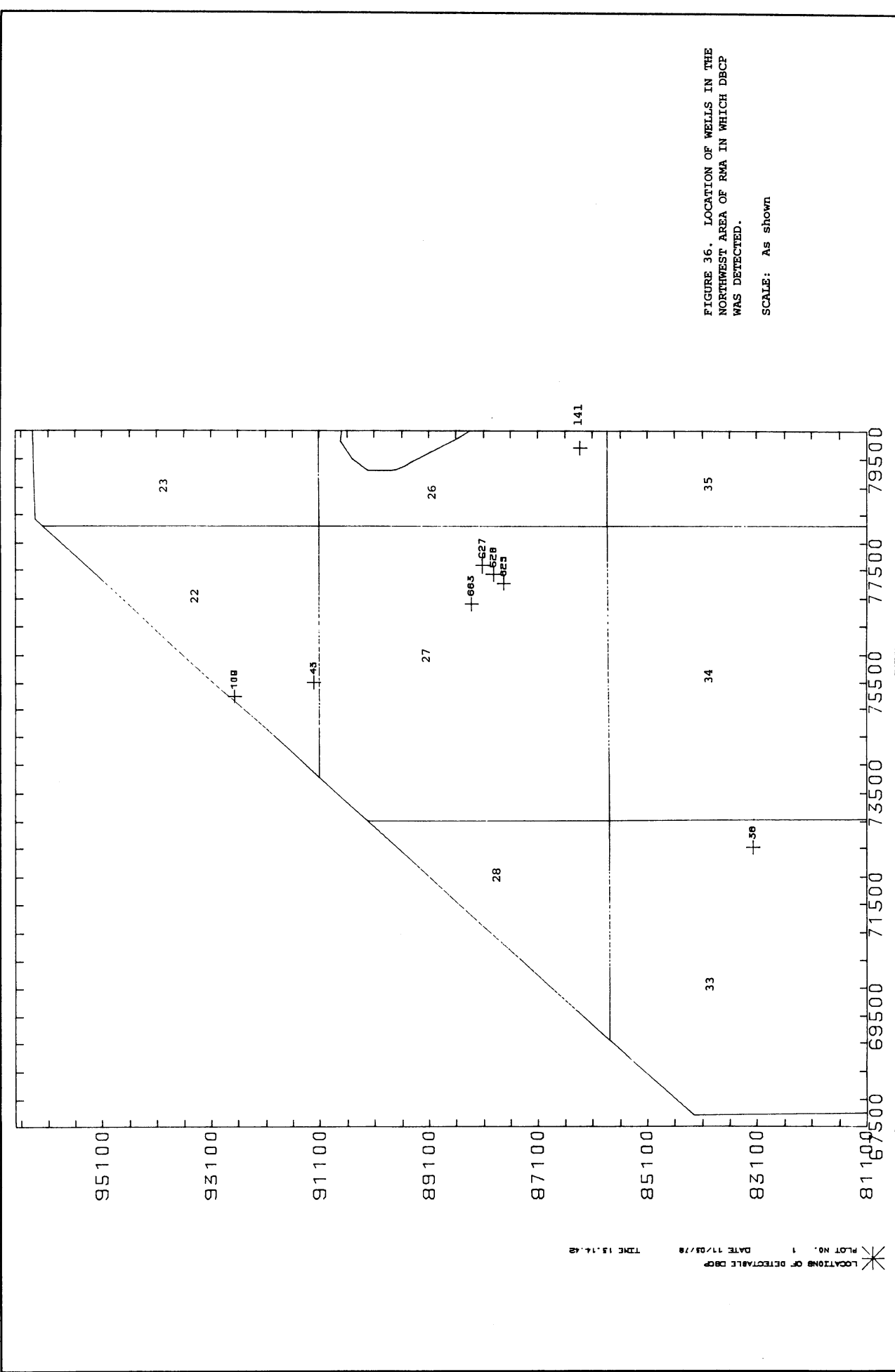

FIGURE 36. LOCATION OF WELLS IN THE NORTHWEST AREA OF RMA IN WHICH DBCP WAS DETECTED.
SCALE: As shown

LOCATIONS OF DETECTABLE DBCP
 * PLOT NO. 1
 DATE 11/23/78
 TIME 15.14.48

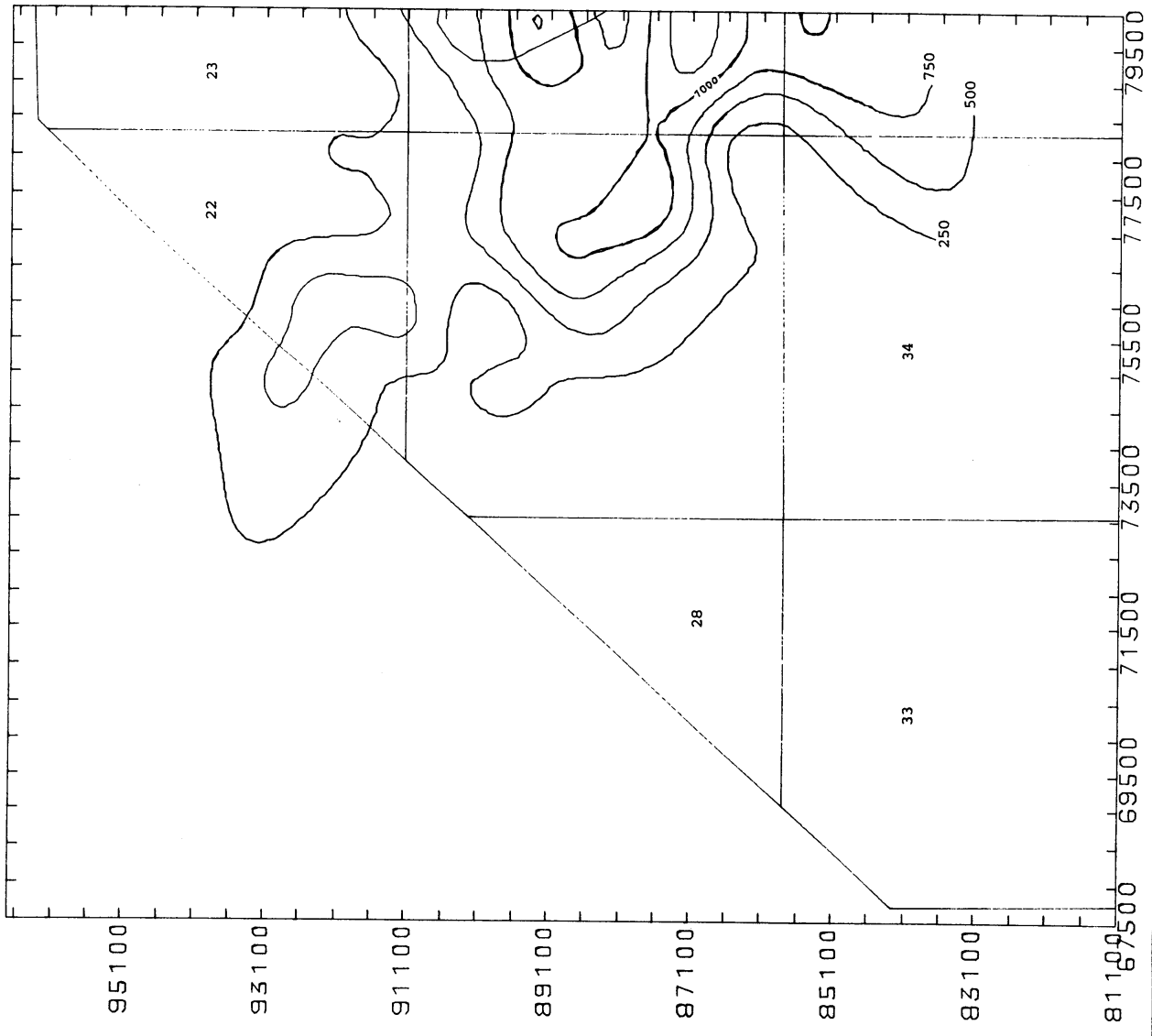

FIGURE 37. DISTRIBUTION OF CHLORIDE
 IN THE NORTHWEST AREA OF RMA.
 SCALE: AS SHOWN
 CONTOUR INTERVAL: 250 ppm

* CHLORIDE DISTRIBUTION
 PLOT NO. 1
 DATE 11/03/78
 TIME 18.01.18

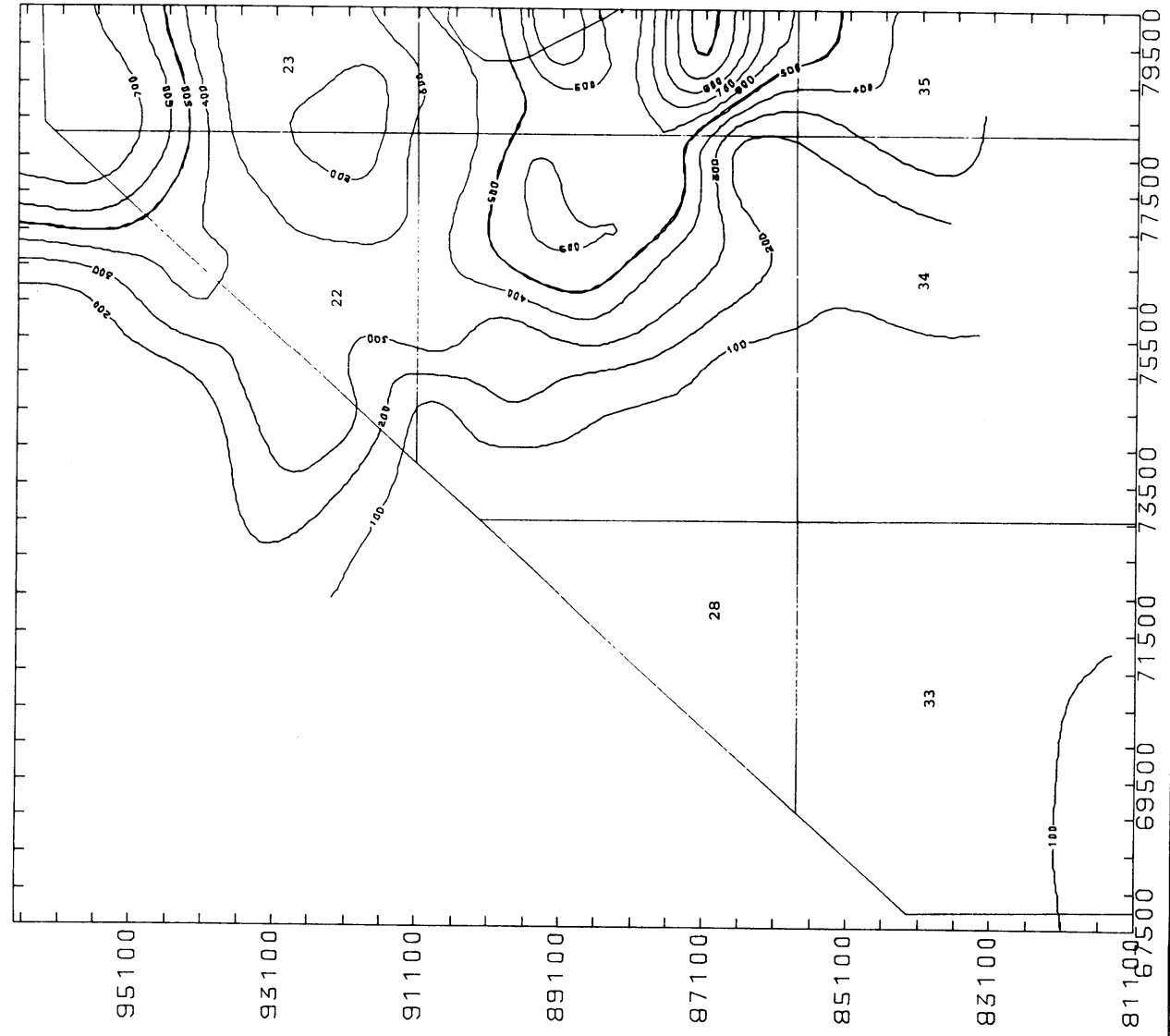

FIGURE 38. DISTRIBUTION OF SODIUM
 IN THE NORTHWEST AREA OF RMA.
 SCALE: As shown
 CONTOUR INTERVAL: 100 ppm

*
 SODIUM DISTRIBUTION
 PLOT NO. 1
 DATE 11/23/78
 TIME 18:48:05

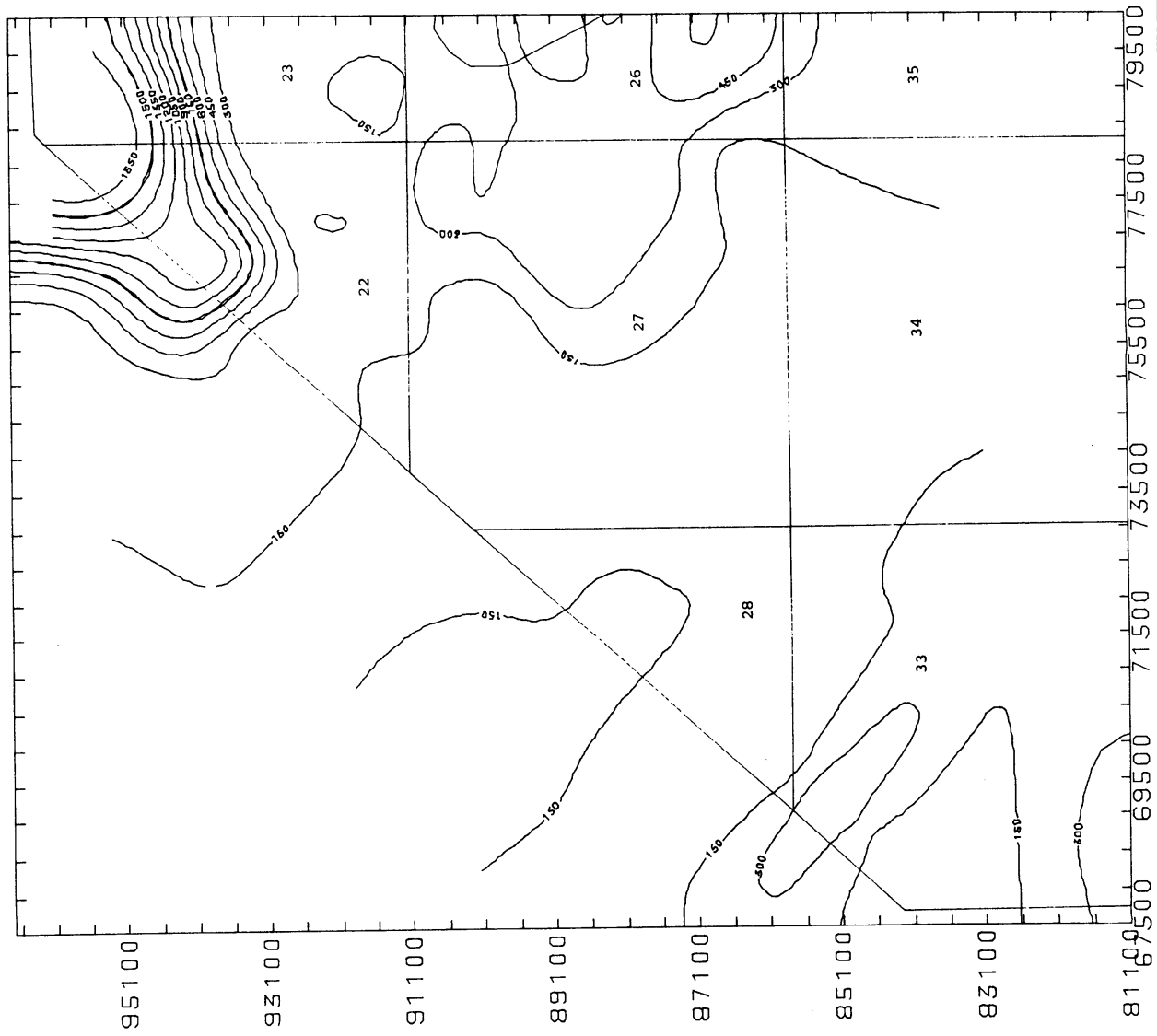

FIGURE 39. DISTRIBUTION OF SULFATE
IN THE NORTHWEST AREA OF RMA.

SCALE: As shown

CONTOUR INTERVAL: 150 ppm

SULFATE DISTRIBUTION
 PLOT NO. 1
 DATE 11/23/78
 TIME 18.58.27