



**SURVIVABILITY - SUSTAINABILITY - MOBILITY
SCIENCE AND TECHNOLOGY
SOLDIER SYSTEM INTEGRATION**

TECHNICAL REPORT
NATICK/TR-95/015

AD _____

COMPARISON OF EQUIPMENT FOR DRYING FOODS

by

Markus Langner, Fred Colhoun, Arpan Mahorowala

Department of Chemical Engineering,
Massachusetts Institute of Technology

Joseph S. Cohen and Linnea Hallberg

January 1995

Final Report

June 1994 - July 1994

19950203 383

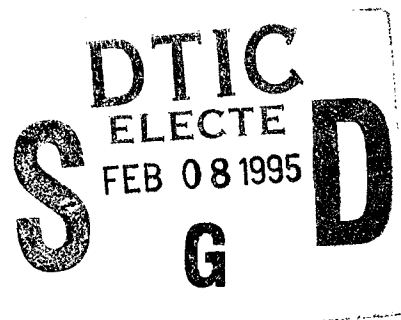

Approved for Public Release, Distribution Unlimited

**UNITED STATES ARMY NATICK
RESEARCH, DEVELOPMENT AND ENGINEERING CENTER
NATICK, MASSACHUSETTS 01760-5000**

SUSTAINABILITY DIRECTORATE

DISCLAIMERS

The findings contained in this report are not to be construed as an official Department of the Army position unless so designated by other authorized documents.

Citation of trade names in this report does not constitute an official endorsement or approval of the use of such items.

DESTRUCTION NOTICE

For Classified Documents:

Follow the procedures in DoD 5200.22-M, Industrial Security Manual, Section II-19 or DoD 5200.1-R, Information Security Program Regulation, Chapter IX.

For Unclassified/Limited Distribution Documents:

Destroy by any method that prevents disclosure of contents or reconstruction of the document.

REPORT DOCUMENTATION PAGE

Form Approved
OMB No. 0704-0188

Public reporting burden for this collection of information is estimated to average 1 hour per response, including the time for reviewing instructions, searching existing data sources, gathering and maintaining the data needed, and completing and reviewing the collection of information. Send comments regarding this burden estimate or any other aspect of this collection of information, including suggestions for reducing this burden, to Washington Headquarters Services, Directorate for Information Operations and Reports, 1215 Jefferson Davis Highway, Suite 1204, Arlington, VA 22202-4302, and to the Office of Management and Budget, Paperwork Reduction Project (0704-0188), Washington, DC 20503.

1. AGENCY USE ONLY (Leave blank)	2. REPORT DATE January 1995	3. REPORT TYPE AND DATES COVERED June 1994 - July 1994	
4. TITLE AND SUBTITLE COMPARISON OF EQUIPMENT FOR DRYING FOODS		5. FUNDING NUMBERS	
6. AUTHOR(S) Markus Langner,* Fred Colhoun,* Arpan Mahorowala,* Joseph S. Cohen, and Linnea Hallberg		FTBB 1313 PR: ID:TB-PST	
7. PERFORMING ORGANIZATION NAME(S) AND ADDRESS(ES) U.S. Army Natick Research, Development and Engineering Center Kansas St., ATTN: SATNC-WRA Natick, MA 01760-5018		8. PERFORMING ORGANIZATION REPORT NUMBER NATICK/TR-95/015	
9. SPONSORING / MONITORING AGENCY NAME(S) AND ADDRESS(ES)		10. SPONSORING / MONITORING AGENCY REPORT NUMBER	
11. SUPPLEMENTARY NOTES * Practice School student, Department of Chemical Engineering, Massachusetts Institute of Technology			
12a. DISTRIBUTION / AVAILABILITY STATEMENT Approved for public release, distribution unlimited		12b. DISTRIBUTION CODE	
13. ABSTRACT (Maximum 200 words) This report deals with the comparison of equipment for drying peas. Dryers investigated were the ball dryer (BD), the centrifugal fluidized bed dryer (CF) and the microwave-augmented freeze dryer (MW). Peas dried in each unit were rehydrated and subjected to quality tests for color and texture. The MW gave the best quality peas. An economic comparison was also made. Calculation of fixed-capital, utility, operating and manufacturing costs were based on data from Sapakie and Renshaw (1984) and measurements made on the pilot scale equipment. The manufacturing costs of the CF peas were marginally less than that of the BD peas. The MW peas were about four times more expensive than the BD peas. A trade-off between quality and economics arises. Processing strategies to resolve this conflict are suggested. Operating conditions and equipment modifications are recommended for the pilot-scale equipment. <p style="text-align: center;">DTIC QUALITY INSPECTED 4</p>			
14. SUBJECT TERMS MOST COMPARISON EQUIPMENT VEGETABLES CARROTS DRYING FOODS FREEZE DRYING PEAS DRIED VEGETABLES REHYDRATION BEANS DRYING APPARATUS COMPARISON ANALYSIS			15. NUMBER OF PAGES 59
			16. PRICE CODE
17. SECURITY CLASSIFICATION OF REPORT Unclassified	18. SECURITY CLASSIFICATION OF THIS PAGE Unclassified	19. SECURITY CLASSIFICATION OF ABSTRACT Unclassified	20. LIMITATION OF ABSTRACT

TABLE OF CONTENTS

	<u>Page</u>
List of Figures	v
List of Tables	vi
Preface	vii
Summary	1
Introduction	2
Background	2
Objectives of the Project	3
General Method of Approach	3
Equipment and Procedures	3
Ball Dryer (BD)	3
Centrifugal Fluidized Bed Dryer (CF)	5
Microwave Augmented Freeze Dryer (MW)	7
Results and Discussion	9
Equipment Performance	9
Ball Dryer	9
Centrifugal Fluidized Bed Dryer	10
Microwave Augmented Freeze Dryer	13
Quality Results	13
Quality Under Different Operating Conditions	16
Ball Dryer	16
Centrifugal Fluidized Bed Dryer	18
Microwave Augmented Freeze Dryer	19
Cross Equipment Comparison	21
Discussion of Errors in the Quality Results	22
Conclusions	23
References	24
Appendix A - Cost Comparisons	25
Operating Costs of Pilot Scale Equipment	25
Microwave Augmented Freeze Dryer Cost Data	26
Costs of Commercial Scale Equipment	26
Fixed Cost Calculations	27
Manufacturing Cost Calculations	34
References	35

Appendix B - Additional Results and Discussion	41
Ball Dryer: Comparison of Previous and Current Moisture Results	41
Effect of Feeder on Ball Dryer Quality	42
Other Ball Dryer Problems	44
References	44
Appendix C - Recommendations	45
Recommendations for Commercial Equipment Installation	45
Recommended Operating Conditions for Each Pilot Equipment	47
Recommendations for Improvement of Pilot Scale Equipment	47
Ball Dryer	47
Centrifugal Fluidized Bed Dryer	48
Microwave Augmented Freeze-Dryer	48
Appendix D - Sample Calculations	49
Microwave Augmented Freeze Dryer	49
Determination of Cooling Water Flow rate	49
Sample CF Run Cost Calculation	49
Minimum Fluidization and Terminal Velocity Calculations	50
Number of Operating Days for the Plant	51

Accession For	
NTIS	<input checked="" type="checkbox"/>
CRA&I	<input type="checkbox"/>
DTIC	<input type="checkbox"/>
TAB	<input type="checkbox"/>
Unannounced	<input type="checkbox"/>
Justification	
By	
Distribution /	
Availability Codes	
Dist	Avail and/or Special
A-1	

List of Figures

	<u>Page No.</u>
1. Schematic Diagram of Ball Dryer	4
2. Schematic Diagram of Centrifugal Fluidized Bed Dryer	6
3. Schematic Diagram of Microwave Augmented Freeze Dryer	8
4. Drying Curve for Centrifugal Fluidized Bed Dryer	11
5. Microwave Drying Curves	14
6. Effect of Platens on Drying at 250 W Microwave Power	15
A-1. Hypothetical Dryer	28
A-2. Cost Comparison of Dryers, Fixed and Variable Costs	38
A-3. Cost Comparison of Dryers, Variable Costs	39
A-4. Cost Comparison of Dryers, Selected Variable Costs	40
C-1. New Drying Strategies	46

List of Tables

1.	Operating Conditions for Ball Dryer	9
2.	Fluidization Calculations	12
3.	Ball Dryer Quality Values	16
4.	Operating Conditions for Ball Dryer	17
5.	Effect of Inlet Air Temperature on Quality Values	17
6.	ANOVA of Ball Dryer Quality Values	17
7.	Centrifugal Fluidized Bed Dryer Quality Results	18
8.	ANOVA of Centrifugal Fluidized Bed Quality Values	19
9.	Microwave Augmented Freeze Dryer Quality Results	20
10.	ANOVA of Microwave Augmented Freeze Dryer Values	20
11.	Quality Comparison Summary	21
12.	ANOVA for Quality Comparisons	21
13	Effect of Temperature on Moisture Measurements	23
A-1.	1983 Utility Costs for Drying 2 kg of Peas	25
A-2.	Microwave Power Breakdown	26
A-3.	Microwave Power Supply Cost	26
A-4.	Comparison to Sapakie and Renshaw Processing Conditions	27
A-5.	Fixed Cost Calculations	29
A-6.	Manufacturing Cost Calculations	29
A-7.	1983 Dryer Utility Costs	31
A-8.	1983 Manufacturing Cost Summary	32
A-9.	Utility Costs	32
A-10.	1994 Utility Costs	33
A-11.	Overall Cost Summary, 1994	33
A-12	Relative Manufacturing Costs	33
A-13.	1983 Cost Calculations	36
A-14.	1994 Cost Calculations	37
B-1.	Effect of Feed Type on Ball Dryer	43
D-1.	Steam Flow Rate	49

PREFACE

This study was undertaken during the period June 1994 to July 1994 at the U.S. Army Natick Research, Development and Engineering Center, Natick MA. The funding was FTBB 1313, Project ID:TB-PST.

We would like to thank Joseph Cohen and Linnea Hallberg of the Sustainability Directorate at Natick for their help and guidance. We are grateful to Dr. Michael Mohr, Massachusetts Institute of Technology Practice School Director, for his technical advice. We are also thankful to Assistant Director Colleen Vandevoorde for her suggestions.

Citation of trade names in this report does not constitute an official endorsement of the product.

Markus Langner
Fred Colhoun
Arpan Mahorowala

COMPARISON OF EQUIPMENT FOR DRYING FOODS

Summary

This study presents a comparison of equipment for drying peas. The dryers investigated were the ball dryer (BD), the centrifugal fluidized bed dryer (CF), and the microwave augmented freeze dryer (MW). Peas were dried in each unit from an initial 78% moisture to a final 5 to 10% moisture. (Freeze dried peas are currently commercially available at 3% moisture and military specifications specify less than 2%.)

The dried peas were rehydrated and subjected to quality tests for color and texture within 24 to 48 hours of drying. They were held at 45 F (7 C). Frozen peas that had been placed in boiling water served as control samples for similar measurements.

The MW gave the best quality. There was no significant difference in the quality between the MW and the control. The color of both the BD and CF peas was different than that of the control. The CF peas were the hardest.

An economic comparison was made among all the technologies. Fixed capital costs for drying capacities of 1,000 and 10,000 lb per hour (454 and 4,540 kg per hour) of water removed were calculated from purchased equipment costs listed by Sapakie and Renshaw (1984).¹ Relative utility costs were estimated from measurements made on the pilot scale equipment.

Operating costs were obtained by scaling the utility costs from Sapakie and Renshaw (1984) and including labor costs. Finally manufacturing costs were calculated based on the assumptions of Sapakie and Renshaw (1984). The manufacturing costs of the CF were marginally less than those of the BD. The MW manufacturing costs were about four times as great as those of the BD. For a 1,000 lb per hour capacity for the BD, CF, and MW, the manufacturing costs were respectively 0.32, 0.25 and 1.16 dollars per lb (0.70, 0.55 and 2.55 dollars per kg) of dried peas. These costs compare with 1.29 dollars per lb (2.84 dollars per kg) for the current freeze-drying process.

The trade-off between quality and economics is discussed. Several drying strategies aimed at achieving better product quality at a lower cost are recommended. Operating conditions and equipment modifications are recommended for the pilot scale equipment.

Introduction

Background

Two important components of a soldier's diet are fruits and vegetables. The Army and especially the Navy often require these products to be dried. The Sustainability Directorate at the US Army Natick Research, Development and Engineering Center is investigating different drying technologies to increase the shelf stability of fruits and vegetables and to reduce the mass of military rations. Three types of specialized drying equipment are located at the Center:

Ball Dryer (BD)

Centrifugal Fluidized Bed Dryer (CF)

Microwave Augmented Freeze Dryer (MW)

Schematic diagrams of these dryers are shown in the Equipment and Procedures Section.

Prior work has been done on three dryers using whole peas, sliced green beans and diced carrots. (Cohen, Hallberg and Yang, 1994)². This work was designed to identify the parameters that have a significant effect on product quality.

Peas are used as a representative vegetable in this study. They are ideal samples because of their spherical geometry and regular size. The commercial pea product quality must meet the military specifications.³ According to this specification, the peas should not be scorched or damaged by heat or drying. They must be compressed into discs and have a final moisture content of less than 2%.

Sapakie, Mihalik and Hallstrom⁴ (1979) point out seven factors which influence the selection of a dryer:

1. Properties of feed material
2. Drying characteristics of drying material
3. Material flow
4. Product qualities
5. Recovery concerns
6. Available facilities
7. Economics

Before these drying technologies can be commercialized, further data are required to compare the quality of the product resulting from each process. Moreover, the relative costs of the commercial-scale equipment must be determined.

Objectives of the Project

The current production process is very expensive. Technologies with lower production costs but comparable product quality are desired. The objectives for this project are to:

1. Compare the quality of the reduced moisture peas produced by the three types of equipment.
2. Compare the cost effectiveness of the three technologies.
3. Establish the trade-off between quality and cost.

General Method of Approach

For each experimental run 4.4 lb (2 kg) of peas with initial moisture content of 78% were dried to a consistent end point of approximately 5 to 10% moisture. Moisture measurements were made with a Computrac™ moisture analyzer. The processing parameters such as cooling water flow rate and power consumption were recorded to determine the operating costs of each type of equipment. To complete the economic analysis, the fixed capital cost and the manufacturing cost of each equipment were estimated. After drying, the peas were rehydrated and subjected to quality tests for color and texture.

Equipment and Procedures

Ball Dryer (BD)

The BD is a Precision Drying Systems (PDS) Ball Dryer Model 25N™ (Figure 1). Peas are fed to the drying chamber through a screw conveyor (or hopper, funnel, etc.), where they come in contact with hot polyester balls. The drying chamber is heated by air, which also aids the flow of peas through the sieve and through the product exhaust pipe to the product discharge cyclone. A rotating inner cylinder moves the polyester balls from the bottom of the chamber to the top, ensuring constant circulation of the balls and downward flow of the product.

For the BD, the rotation rate of the interior cylinder, the air temperature and the feed rate of the peas were investigated in previous experiments.² The first two parameters affected product quality. The rotational speed of the interior cylinder is the most significant parameter affecting the residence time of the peas and, therefore, their final moisture level.

Previous experiments indicated that a rotational speed of 1.2 revolutions per minute (rpm) resulted in a final moisture level of

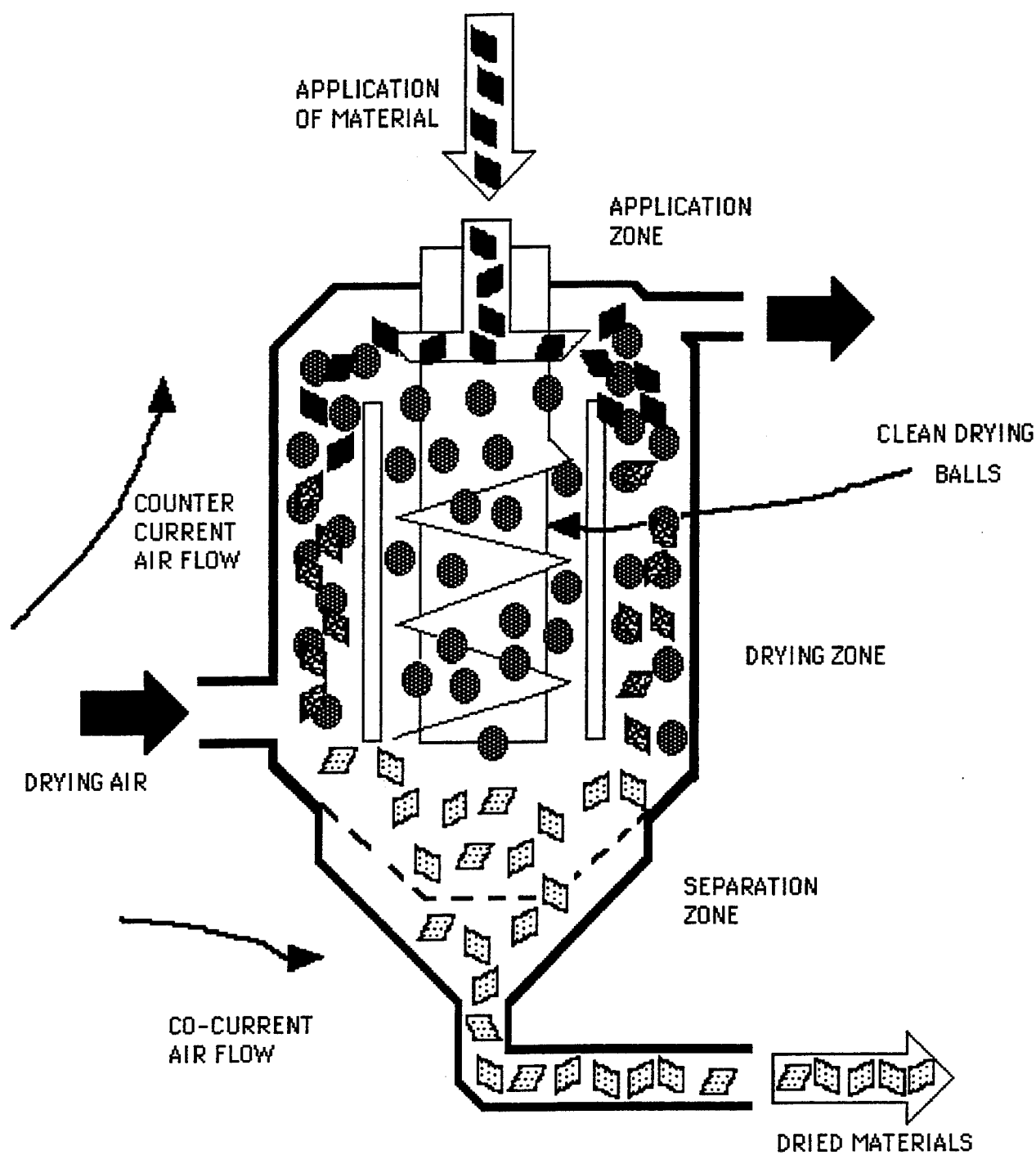

FIGURE 1 - SCHEMATIC DIAGRAM OF BALL DRYER

approximately 5%² The other parameters were an inlet temperature of 180 F (82 C) and a 10% feed rate. (This value refers to the setting of the variable speed drive of the screw conveyor.) These experiments also showed that there is no significant difference between a 10 and 15% feed rate.

The parameters for the experiments in this portion of the study were:

1. Inlet air temperatures: 170, 220 F (77, 104 C)
2. Inner cylinder speed: 0.75, (1.2 rpm)
3. Feed rate: 20%

Centrifugal Fluidized Bed Dryer (CF)

The CF is an APV Mitchell (Dryers) Ltd.TM centrifugal fluidized bed dryer (Figure 2). The equipment consists of a cylindrical chamber whose rotational speed is controlled by a variable speed drive. The peas are placed in this chamber. Hot air (heated by steam in a heat exchanger) is mixed with ambient air. The air mixture enters through the bottom surface of the chamber.

Fluidized beds have been used in the food industry for drying. For large and relatively low-density particles such as peas, the transition from fixed-bed conditions to the slugging conditions is almost immediate with increasing gas velocity. This transition is undesirable from the viewpoint of gas-to-solid contact as the intimate contact desired will not occur.

The CF overcomes this limitation by subjecting the food particles to a centrifugal force greater than the gravitational force, which has the effect of increasing the apparent density of the particles and allowing homogenous fluidization. More importantly, proper fluidization, in which the particles are levitated and achieve intimate contact with the heated air, can be achieved at any desired gas velocity by varying the centrifugal force. Centrifugal force allows the bed operating parameters to be set independently of the physical properties of the material being fluidized.

The most significant parameter for the CF is the air temperature in the drying chamber. The rotation rate of the centrifuge and the air flow rate are important to achieve fluidization of the peas.

The parameters for the experiments in this portion of the study were:

1. Air flow rate: 25 cubic feet per s (cfs) (0.71 cubic m per s)
2. Rotation rate of drying chamber: 60, 150 revolutions per min (rpm)
3. Air temperature: 50, 80 C (122, 176 F)

These values lie in the range of those used by Cohen, Hallberg and

Yang² (1994). However the drying time was extended to 120 minutes (from 15 to 20 minutes) to achieve the desired final moisture content of 5 to 10%.

Microwave Augmented Freeze Dryer (MW)

The MW equipment (Figure 3) was custom-made by Cober ElectronicsTM. The MW works on the principle of subliming moisture from a sample. Frozen peas are placed on a tray in the chamber. The chamber is refrigerated and evacuated. The heat of sublimation is supplied to the peas volumetrically with microwaves and by radiation from a platen under the tray. The mass of the sample is monitored by a scale, which supports the sample tray. The removed moisture is condensed on coils in the rear of the chamber.

The effect of platen temperature, load mass and microwave power were investigated in previous experiments.⁵ Only the power had an effect on product quality. Both the load mass and the power affected the drying time.

The parameters for the experiments in this portion of the study were:

1. Platen temperature: 150 F (66 C).
2. Chamber pressure: approximately 12 Pa
3. Microwave power: 0, 250, 500 W

The values for the microwave power were selected to facilitate comparisons with existing data. While previous experiments were run at a microwave power of 750 W, the extra power did not significantly shorten the drying time. In addition, there were problems with corona formation and arcing inside the dryer at this power level. The chamber should be operated at a low pressure to increase the driving force for the sublimation process and to reduce the likelihood of corona formation and arcing. The lowest pressure the vacuum pump can maintain is about 12 Pa. The platen temperature is thought to be relatively unimportant⁶. The platen temperature of 150 F was chosen to facilitate comparison with previous experiments. To test the hypothesis that the platen temperature is unimportant, a run was made in which no power was supplied to the platen.

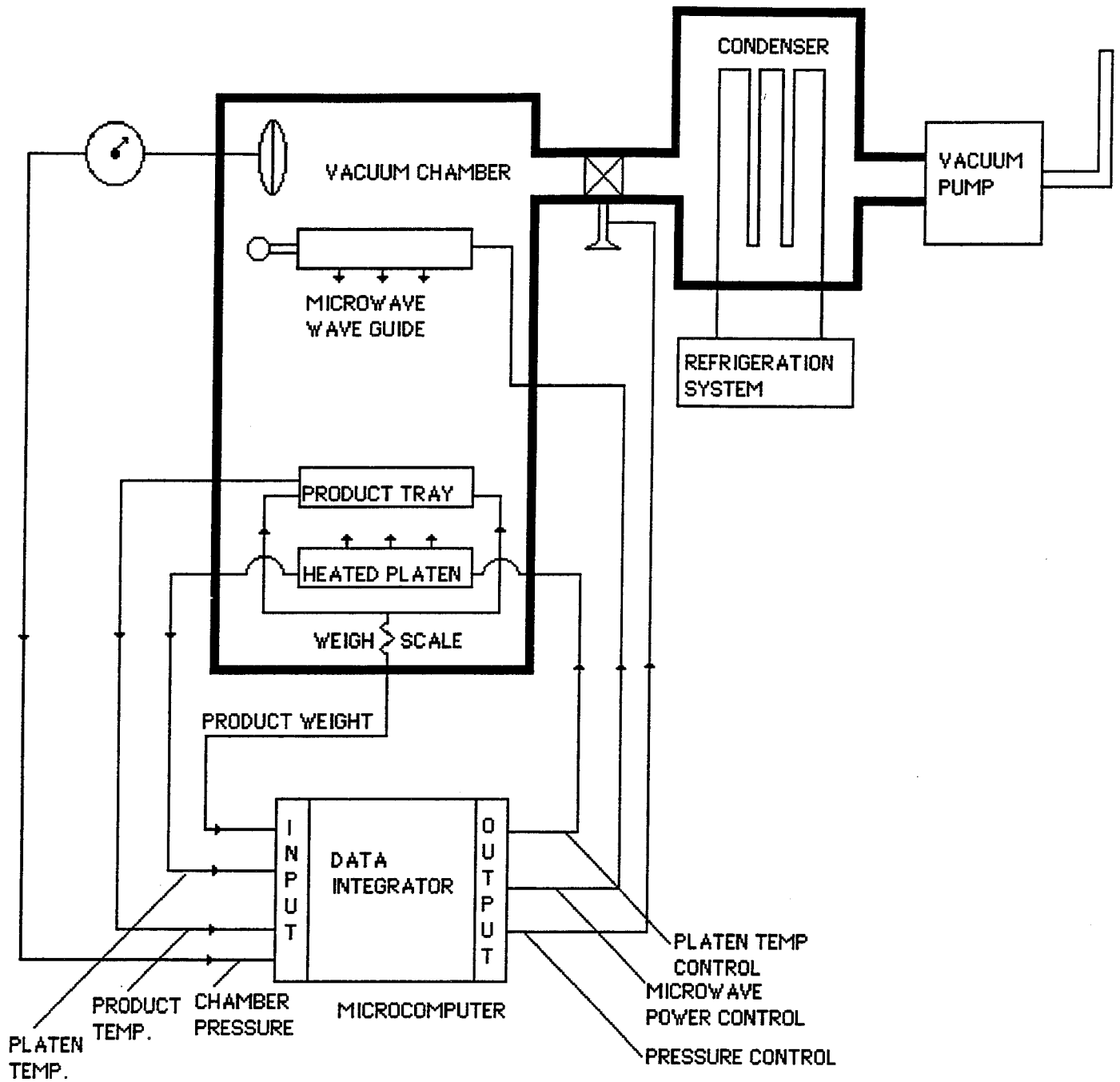

FIGURE 3 - SCHEMATIC DIAGRAM OF MICROWAVE AUGMENTED FREEZE-DRYER

Results and Discussion

Equipment Performance

Ball Dryer

The operating conditions and final moisture for all runs are summarized in Table 1. Runs 1 and 5 were ended prematurely.

TABLE 1 - Operating Conditions for Ball Dryer

Run No.	Inlet Temp. F	Rotational Speed, rpm	Feed Type	Feeds from Run No.	Final % Moisture
2	220	1.2	batch	--	21.1
3	220	0.75	batch	--	12.1
4	220	1.2	funnel	--	19.0
6	220	1.2	screw	--	19.9
7	220	1.2	screw	--	19.3
8	170	1.2	screw	--	34.1
9	170	1.2	screw	--	37.4
10	170	1.2	screw	8, 9	12.0
11	220	1.2	screw	6, 7	4.6

During run 1, at least half of the peas were severely damaged by the screw conveyor. The peas were "mushed", split and their skins came off. Alternative feeding techniques were explored. For run 2, the peas were loaded through the side window of the drying chamber (subsequently referred to as "batch" mode.) The exhaust temperature dropped from 180 F (82 C) to 120 F (49 C) because most of the hot air escaped through the window. After the window was closed, the exhaust temperature did not reach steady-state (180 F) for about an hour. Although the final product was shriveled, it was not otherwise structurally damaged.

During run 4 the peas were fed through a funnel placed on top of the drying chamber. The high air flow rate prevented the peas from falling into the chamber at a steady rate. The funnel required operator intervention for smooth operation. The final moisture content of the peas for the screw conveyor, batch and funnel feeding techniques, with the other operating parameters unchanged, were 19.6% (average of two runs), 21.1%, and 19.0% respectively. (A discussion of the moisture measurements follows.)

The batch feed did not result in a significantly greater final moisture

level (the standard deviation is two percentage points) because the 2 kg feed is small in comparison with the capacity of the equipment. According to the manufacturer, the equipment has a drying capacity of 55 lb (25 kg) of water per hour for a temperature difference of 100F (56 C) between the inlet and the exhaust air. This corresponds to 12.2 lb (5.5 kg) water per hour for a 40 F (25 C) difference (operating condition of 220 F (104 C) runs) or a processing rate of 7.1 kg (14.3 lb) peas per hour. Hence, the feed rate of the screw conveyor can be increased beyond 15% without significantly affecting the final moisture. At the 15% feedrate, the feeding takes almost one hour.

Subsequent experiments were run with the screw conveyor, because it is more convenient to operate and provides a steady feed rate. When comparing the quality of the peas dried by this process to peas dried by the other technologies, the negative impact of the screw conveyor on product quality should be taken into account. This was partially achieved by selecting less damaged peas for the quality measurements.

Run 3 was operated at 0.75 rpm to reduce the moisture to the desired level of 5 to 10%. With an inlet temperature of 220 F (104 C) the final moisture content was 12.1%. While this moisture is closer to the target value, the torque of the motor at 0.75 rpm is very small and is occasionally inadequate to turn the interior cylinder. Since the motor can be damaged, a rotational speed of 0.75 rpm should be avoided. The torque at 1.2 rpm is just above the minimum required; therefore, 1.2 rpm was used in all subsequent measurements.

Duplicate runs were performed at 1.2 rpm, a screw conveyor feed rate of 20% and inlet temperatures of 220 F (104 C (runs 6 and 7) and 170 F (77 C) (runs 8 and 9). The products from each duplicate run were combined and fed to the drying chamber for a second pass. (The partially dried peas from runs 6 and 7 were combined in run 10 and the peas from runs 8 and 9 were combined in run 11.) While the minimum rotational speed limits the maximum residence time and, therefore, drying time in the chamber, a second pass effectively doubles the bed length. The moisture level was further reduced to 12.0% (run #10) and 4.6% (run #11).

Centrifugal Fluidized Bed Dryer

Since moisture levels of 5 to 10% had not been achieved in the previous study, the first step was to obtain a drying curve. The operating conditions for this run were an air flow rate of 15 cfs (0.453 cubic m per s), an air temperature of 80 C (176 F) and a rotation rate of 150 rpm. Small

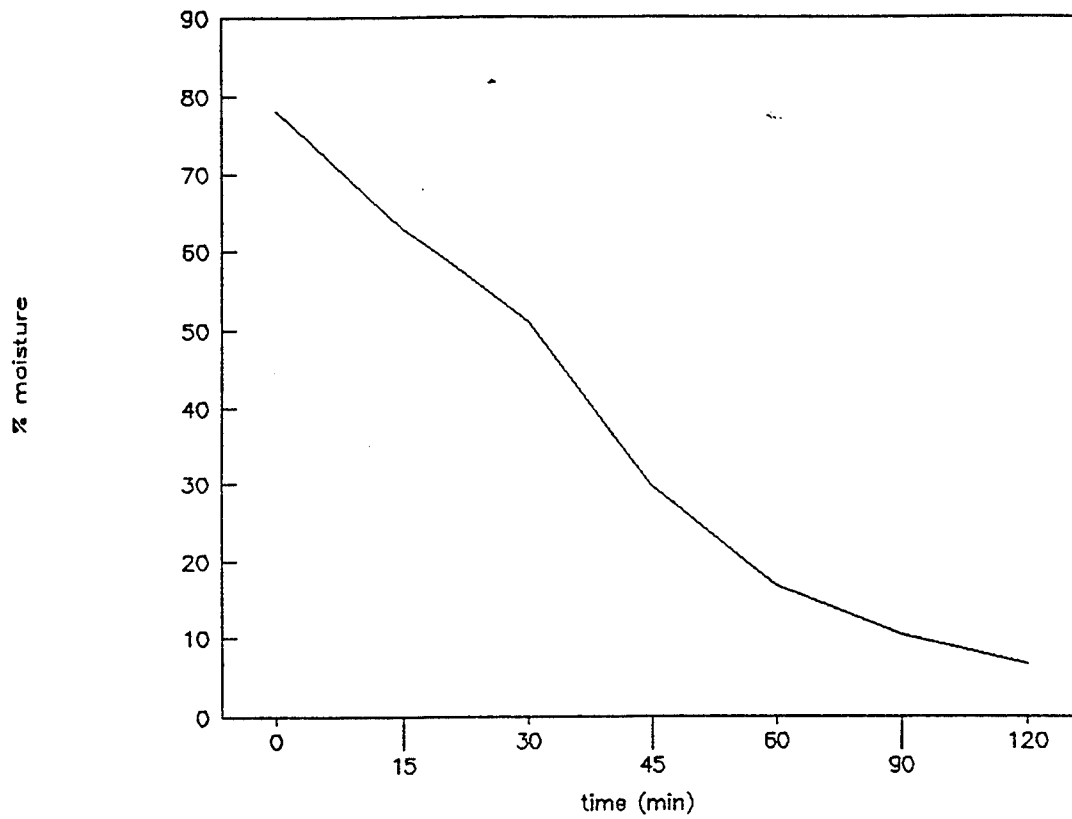

FIGURE 4 - DRYING CURVE FOR CENTRIFUGAL FLUIDIZED BED DRYER

samples of peas were withdrawn for moisture measurements after 15, 30, 45, 60, 90 and 120 minutes. The initial part of the resulting drying curve, Figure 4, agrees with the previous results of Cohen, Hallberg and Yang,² 1994. The moisture content of the peas after 120 minutes was 6.6%.

The consumption of power at 100 psig (690 kPa) did not vary significantly for all subsequent experiments. On average, 16 kWh of electricity and 670 lb (300 kg) of steam were consumed for each two-hour run.

The fluidization observed in the centrifugal chamber was not effective. Increasing the air flow rate to the maximum possible did not improve the fluidization. The minimum fluidization and terminal velocities for frozen and dehydrated peas were calculated. The calculations are shown in Table 2.

TABLE 2 - Fluidization Calculations

Type of Peas	Minimum Fluid Velocity	Minimum Fluid Velocity	Terminal Velocity
Percent Moist.	m/s *	m/s**	m/s ***
Frozen (78%)	3.30	3.82	30.81
Dehydrated (7%)	2.67	3.12	25.42

* Goroshko-Rozenbaum-Todes relationship (Farkas, et al.⁷)

** Wen-Yu correlation (Cammarn, et al.⁸)

*** Farkas, et al.⁷

An air flow rate of 15 cfs corresponds to an air inlet velocity of 5.8 m/s. This velocity is well above the minimum fluidization velocity (and less than the terminal velocity) for peas and therefore should cause fluidization. However, on entering the drum the air experiences a sudden expansion and as a result, the air velocity drops. This reduced air velocity may be insufficient to fluidize the peas, even when operating at the highest possible air flow rate for this equipment.

The peas tended to stick to the centrifuge walls during the 150 rpm runs. These runs were briefly stopped to scrape off the peas from the wall.

During the 50C (122 F) runs the CF equipment frequently overheated and shut down. The equipment was allowed to cool. These runs were extended to compensate for the down time. The air heater has a constant heat duty. To operate the CF at lower temperatures, more ambient air

must be sucked in. This increase in the load on the blower causes the circuit breaker to trip and the dryer to shut down. The heated mixture of recycled and ambient air is partially vented to maintain a constant air flow rate.

Microwave Augmented Freeze Dryer

The microwave power output was the main parameter investigated.

Figure 5 shows the effect of microwave power on the drying of the peas. Runs were stopped when the sample mass did not change appreciably for 15 minutes. As the microwave power was increased, the drying time decreased. The drying times were 5, 7 and 17 hours for 500, 250 and 0 W, respectively. The reproducibility for the 500 and 250 W drying curves is good. A duplicate run for 0 W power was not performed. If the data are converted to percent moisture as a function of time, "noise" in the drying curve is damped at high moisture levels while it is amplified at lower moisture levels. The average final moisture levels were calculated from the drying curves using a 72% initial moisture level. (See Discussion of Errors in Moisture Results).

The values are 2.1, 3.9 and 4.1% for 500, 250 and 0 W of microwave power, respectively. The moisture content of the dried samples were also measured in the moisture analyzer. These values were 6.0, 14.6 and 7.5% for the 500, 250 and 0 W.

Figure 6 shows the effect of the heating platen on drying at a microwave power of 250 W. Five instead of four hours were required to reach a 1.10 kg (2.4 lb) product mass with the platen turned off. Therefore the platen significantly reduces the drying time. This effect will be more pronounced if the sample is closer to the platen

Quality Results

The dried peas were rehydrated in boiling water for two minutes and then subjected to several quality tests. The control samples were the frozen peas used as raw material for the dryers. The frozen peas were also boiled for two minutes prior to the quality tests.

The rehydration ratio (RR) is a measure of how much water the dried peas are able to absorb. It is defined as the mass of water absorbed divided by the mass of the unhydrated sample.

HunterTM reflectance measurements characterize the color of the peas. In these measurements, three parameters were measured. A greater "L" value means a lighter sample. "a" represents the redness/greenness of the

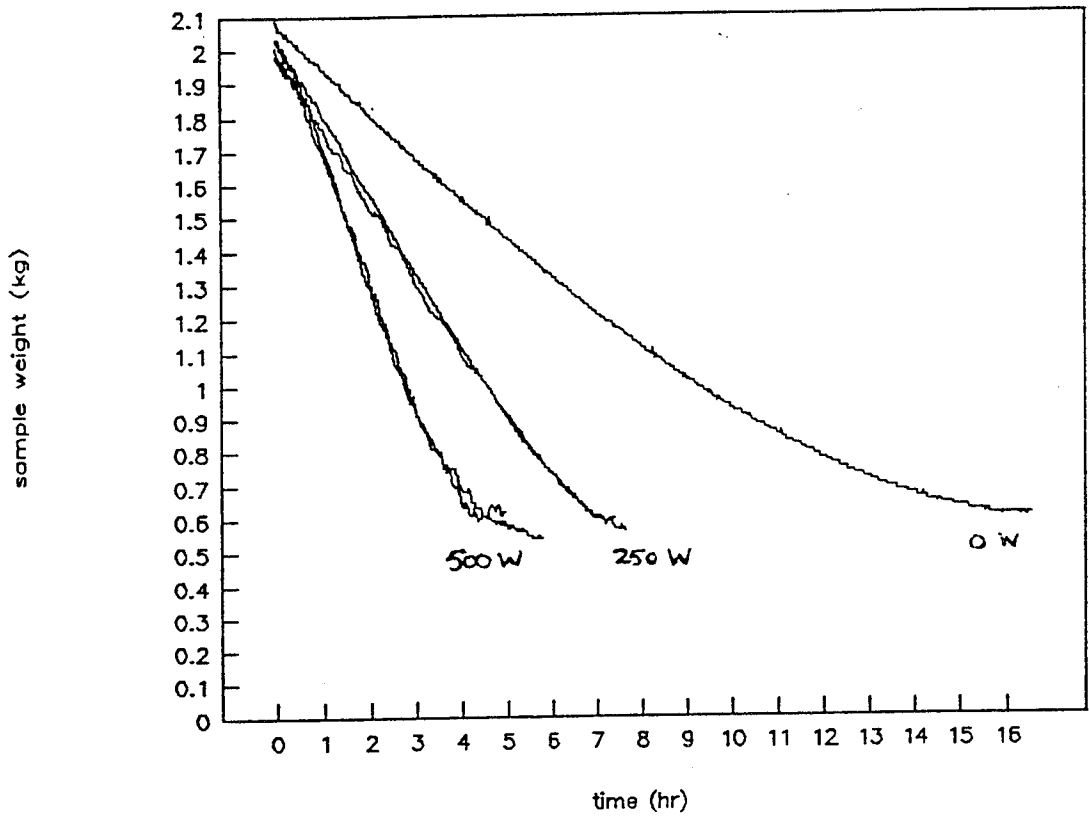

FIGURE 5 - MICROWAVE DRYING CURVES

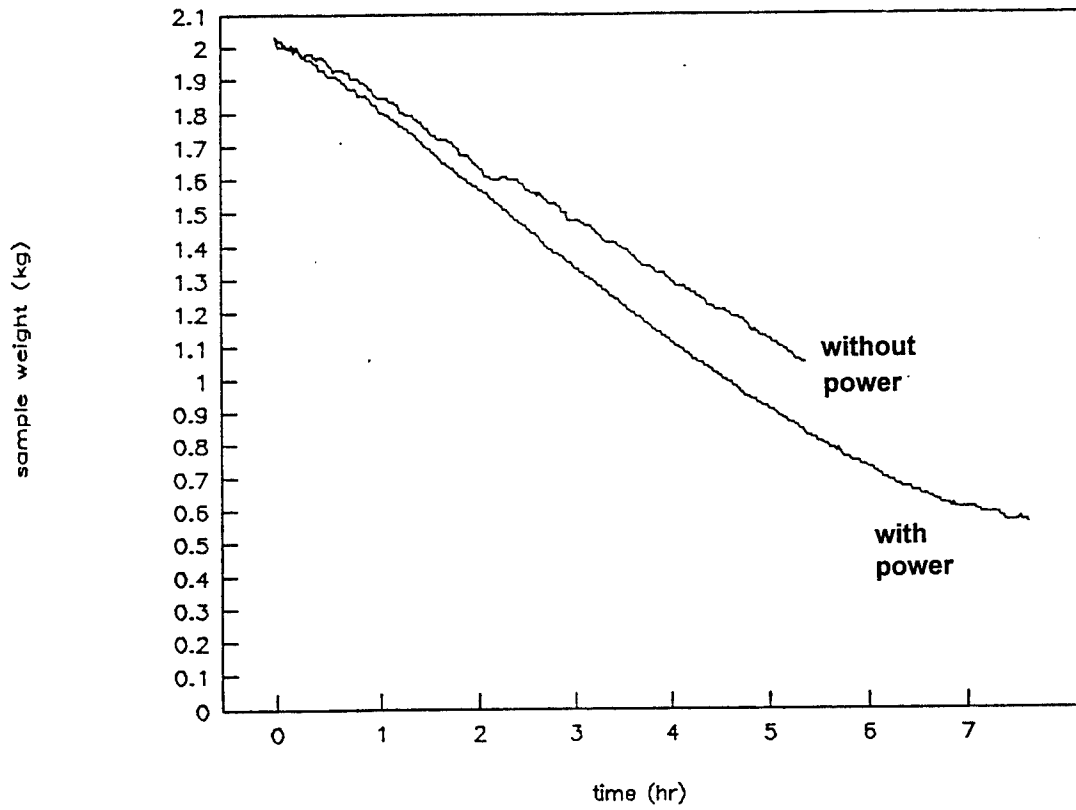

FIGURE 6 - EFFECT OF PLATENS ON DRYING AT 250 W MICROWAVE POWER

sample. A more negative “a” value means a greener sample. “b” represents the yellowness/blueness of the sample. A greater “b” value means a yellower sample.

Shear force measurements characterize the texture of the peas. The peak shear force is the maximum force required while cutting through the sample. The area under the force vs. distance curve is the total required to cut through the peas. A lesser peak force and area (work) implies a more tender sample. Tests on the BD, MW, and control samples needed seven peas to cover the single slit while the tests on CF samples required eight peas. The CF results were scaled by a factor of 7/8 for comparison.

Quality Under Different Operating Conditions

Ball Dryer

The quality results of the peas after the first pass through the BD are shown in Table 3. The reported values are the mean of four measurements, except for the rehydration ratio, which is the mean of two measurements, and the moisture level, which is a single measurement.

Table 3 - Ball Dryer Quality Values

Run No.	Inlet Temp. F	Percent Moist.	“L”	“a”	b”	Rehyd. Ratio	Peak Force, N	Work Nm
6	220	19.9	27.4	-6.30	11.6	1.07	49.7	0.429
7	220	19.3	28.9	-6.86	12.6	1.16	53.0	0.442
8	170	34.1	31.0	-8.06	13.9	1.11	54.2	0.402
9	170	37.4	32.0	-9.58	15.8	1.05	52.9	0.371
control	n/a	78.0	33.0	-8.97	14.4	n/a	60.0	0.403

The negative impact of the screw conveyor on product quality was partially offset by selecting less damaged peas for the quality measurements. (The sections on the operating conditions and the effect of the feeder give more detail.)

The quality results of runs 6 to 9 must be interpreted carefully because the final moisture contents are not the same. Regardless of the processing temperature, a lower moisture content of the dried peas will result in a lower quality upon rehydration. Hence, significant differences in the quality must be attributed to a combination of the final moisture content and the processing temperature.

The dried peas from runs 3 and 10, however, have about the same final moisture and can be compared. The operating conditions for these runs are presented in Table 4.

Table 4 - Operating Conditions for Ball Dryer

Run Number	Inlet Temp. F	Cylinder Speed rpm	Feed Type	Feeds From Run No.	Final Percent Moisture
3	220	0.75	batch	n / a	12.1
10	170	1.20	screw	8 and 9	12.0

The effective residence times, a function of the cylinder speed and the number of passes, were different in these two runs in order to achieve the same final moisture content. Hence the effect of temperature can be analyzed with these two runs. Average quality values are given in Table 5.

Table 5 - Effect of Inlet Air Temperature on Quality Values

Sample	"L"	"a"	"b"	Rehyd Ratio	Peak Force, N	Work Nm
220 F	27.88	-5.69	11.76	0.95	71.4	0.524
170 F	28.36	-7.58	13.45	1.33	60.8	0.474
control	33.41	-8.97	14.40	n / a	60.0	0.403

An analysis of variance (ANOVA) was performed on these results and is shown in Table 6. The numbers represent the confidence level of the differences while "nsd" stands for "no significant difference".

Table 6 - ANOVA of Ball Dryer Quality Values

Comparison	L"	"a"	"b"	Rehyd. Ratio	Peak Force, N	Work Nm
220/170 F	nsd	99%	92%	99%	99%	nsd
220 F/control	99%	99.9%	95%	n / a	95%	99%
170 F/control	99.9%	94%	nsd	n / a	nsd	95%

The results of the ANOVA and the trend of the results in Table 5 indicate that the 170 F samples is of a better quality than the 220 F sample. The difference would have been even more significant if the 220 F peas had also been fed with the screw conveyor. (They were fed as a batch.) Some quality parameters of the 170 F peas are not as good as those for the control, namely "L", "a", and the work required to cut the peas. These peas are harder than the control peas.

Centrifugal Fluidized Bed Dryer

The air temperature and the rotation rate were varied in the experiments. The air flow rate was fixed at 15 cfs. The results from these runs are presented in Table 7.

Table 7 - Centrifugal Fluidized Bed Quality Results
(Mean Value \pm Standard Deviation)

Temp. C	rpm	"L"	"a"	"b"	Peak Force, N	Work Nm	Rehyd. Ratio	Percent Moisture
50	150	27.23 \pm 0.99	-6.41 \pm 0.50	11.10 \pm 0.59	57.0 \pm 4.8	0.4 \pm 0.04	1.16 \pm 0.10	12.60 \pm 0.80
50	60	28.96 \pm 1.41	-6.61 \pm 0.47	11.79 \pm 0.78	75.8 \pm 11.7	0.50 \pm 0.05	1.02 \pm 0.07	13.05 \pm 0.33
80	150	26.15 \pm 0.66	-4.26 \pm 0.51	10.32 \pm 0.52	64.3 \pm 8.7	0.47 \pm 0.08	1.05 \pm 0.04	6.24 \pm 1.29
80	60	27.21 \pm 0.67	-3.94 \pm 0.99	11.56 \pm 0.30	75.5 \pm 18.6	0.50 \pm 0.10	0.98 \pm 0.04	7.71 \pm 0.13
control		33.40 \pm 1.07	-8.97 \pm 0.88	14.40 \pm 1.40	60.0 \pm 6.5	0.40 \pm 0.01	n / a	n / a

An ANOVA was performed to compare the quality of the dried peas with the control peas. The color measurement differences for each set of operating conditions are significantly different from the control peas at a confidence level of 99%. There were no significant differences in the peak forces of the texture measurements. The work required to cut through the peas, however, was significantly different at a confidence level of 99%. In general, all CF dried peas were significantly different from the controls.

To understand the dependence of the various quality parameters on the operating conditions, an ANOVA was performed. The results of the analysis are summarized in Table 8.

Table 8 - ANOVA of Centrifugal Fluidized Bed Dryer Quality Values

Quality Parameter	Significance of Temperature	Significance of Rotat. Speed	Favorable Conditions
Percent Moisture	99.9 %	nsd	High Temperature
Rehydration Ratio	95.0 %	99.0%	Low Temperature and high rpm
"L"	99.9 %	99.9%	Low Temperature and Low rpm
"a"	99.9%	nsd	Low Temperature
"b"	95.0%	99.9%	Low Temperature and Low rpm
Peak Work	nsd	99.0%	High rpm
	nsd	90.0%	High rpm

The product color is better when the peas are treated at lower temperatures and rpms. The peas processed at higher rpms have a better texture and rehydration ratio. However, for a fixed drying time, the peas treated at lower temperatures have higher moisture content.

By running the CF for longer times, lower moisture contents can be achieved at lower temperatures. The rpm has conflicting effects on the color and texture of the peas. Since many peas stuck to the wall at higher rpms, the CF should be operated at lower rpms. After taking these factors into account, the 50 C/60 rpm run (Table 7, row 2) gave the best product quality.

Microwave Augmented Freeze-Dryer

The effect of microwave power on the various quality parameters is shown in Table 9. The values for the rehydrated peas are compared to those of the control peas. Each value represents the mean and standard deviation of all measurements for a given set of operating conditions.

Table 9 - Microwave Augmented Freeze Dryer Quality Results
(Mean value \pm Standard Deviation)

Power Watts	Rehyd. Ratio	Percent Moisture	"L"	"a"	"b"	Peak Force, N	Work Nm
Control	n / a	78.00	33.40 \pm 1.07	-8.97 \pm 0.88	14.40 \pm 1.40	60.01 \pm 6.52	0.40 \pm 0.01
500	1.86 \pm 0.11	5.96 \pm 1.72	32.21 \pm 1.56	-8.76 \pm 0.36	13.78 \pm 0.91	61.75 \pm 3.30	0.43 \pm 0.03
250	1.65 \pm 0.10	14.57 \pm 4.35	32.26 \pm 2.02	-8.76 \pm 0.25	14.26 \pm 0.70	55.51 \pm 4.30	0.39 \pm 0.04
0	2.54 \pm 0.21	7.50 \pm 1.30	30.92 \pm 0.10	-10.07 \pm 0.29	14.67 \pm 0.19	54.54 \pm 10.00	0.42 \pm 0.03

An ANOVA was performed to determine which quality differences were significant. The results are presented in Table 10.

Table 10 - ANOVA of Microwave Augmented Freeze Dryer Values

Quality Parameter	Significance	Comments
Rehydration Ratio	99%	MW different from 0 W
"L"	95%	all samples different from 0 W
"a"	99%	all samples different from 0 W
"b"	nsd	no differences
Peak Force	99%	0 and 250 W different from 500 W and control
Work	nsd	no differences

The 0 watt run served as a point of reference because it simulates the current freeze drying technology. There were no significant differences between the control results and either the 500 or 250 watt results for any quality parameter.

When the 0 watt results were compared to the control, there were significant differences at a confidence level of 95% with the "L" and "a" values. Significant differences also appeared in the "a" values when the 0 watt values were compared to either the 250 or 500 watt values.

Lastly, there was a significant difference in the peak force values for the 250 and 500 watt results. Since there is no difference in quality due to the microwave power, it is best to operate at 500 watts because the drying time is shorter.

Cross Equipment Comparison

Since each dryer was run at several different conditions, the peas of the best quality were compared. The best peas from the BD were processed under an inlet air temperature of 170 F (77 C), an inner cylinder rotation rate of 1.2 rpm, a feedrate of 20% and two passes through the dryer. The best CF operating conditions were an air flow rate of 15 cubic feet per s (0.028 cubic meters per s), a rotation rate of 60 rpm and an air temperature of 50 C (122 F). The best MW operating conditions were a microwave power of 500 W and a platen temperature of 150 F (66 C).

Table 11 summarizes the findings.

Table 11 - Quality Comparison Summary
(Mean value \pm Standard Deviation)

Dryer Type	Rehyd. Ratio	Percent Moisture	"L"	"a"	"b"	Peak Force, N	Work Nm
Control	n/a	78.00	33.40 ± 1.07	-8.97 ± 0.88	14.40 ± 1.40	60.01 ± 6.52	0.40 ± 0.01
BD	1.32	11.96	28.36 ± 1.21	-7.58 ± 0.80	13.44 ± 1.38	60.80 ± 1.81	0.47 ± 0.05
CF	1.02	13.05	28.96 ± 1.41	-6.61 ± 0.47	11.79 ± 0.78	75.80 ± 11.7	0.50 ± 0.05
MW	1.86	5.96	32.21 ± 1.56	-8.76 ± 0.36	13.78 ± 0.91	61.75 ± 3.30	0.43 ± 0.03

An ANOVA was performed to detect significant differences for the quality parameters between the control peas and the peas produced by each drying method and also among the different techniques. The results are given in Table 12.

Table 12 -ANOVA for Quality Comparisons

Quality Parameter	Significance	Comments
Rehydration Ratio	99%	All samples different
"L"	99%	BD and CF different from MW and control
"a"	95%	CF different from all others
Peak Force	99%	BD different from all others
Work	95%	All samples different from control

The BD values were significantly different from the control values for the "L", "a" and Work parameters. For the CF peas, all parameters except the Peak Force were significantly different from the control. Every quality parameter was different between CF and MW. In each case, MW gave better results. For the BD, the only significant differences with the MW were in the "L" and "a" values. The significant differences between the BD and CF were with the "a", "b" and Peak Force values. The MW and the control pea quality parameters showed no significant differences. This analysis implies that the MW dried peas have the best quality upon rehydration

Discussion of Errors in the Quality Results

Several factors contribute to the variability in the quality results. First, food products are, in essence, nonhomogenous. A direct comparison of the quality results from this study to previous work was impossible because the control peas were different.

There is also inhomogeneity in the processing of the peas. In the MW, the microwave intensity will vary with position in the dryer. With the BD, there was a large distribution of residence times for the peas. These factors could influence the quality results, depending on how the sample to be analyzed was taken. The CF samples can be considered well mixed.

The shear force measurements are biased. Only the best looking whole peas were selected for these measurements. The average texture quality will be worse than the values in this report if the samples were taken at random.

Moisture measurements have significant errors. The moisture analyzer was operated at 150 C (302 F). At this temperature, the peas were scorched and some solids possibly volatilized. This implies that all the percent moisture values were too high because the instrument could not distinguish between loss of water and solids. Moisture measurements taken at 100 C (212 F) indicated that this was true. The results are summarized in Table 13.

Table 13 - Effect of Temperature on Moisture Measurements

Temperature of Measurement, C	Percent Moisture of Control Peas	Percent Moisture of Run 3 Peas (500 W)
150	78.0	72.0
100	7.4	3.3

The moisture measurements are expected to have a lower accuracy for samples with greater moisture content because the instrument uses an exponential extrapolation to determine the final moisture content.

Conclusions

In this analysis, quality and economic issues have been treated separately. However, when the quality and economic results are considered in light of the objective to provide the best quality peas at the lowest cost, a trade-off arises.

If the most important consideration is the quality of the peas that the soldiers will eat, the obvious choice is to process the peas in the MW.

If the primary objective is to minimize the manufactured cost of the peas, then the peas should be processed in either the BD or CF. However, the resulting product quality would be different. Peas dried by the BD or CF must be evaluated by a sensory panel to determine whether they are of suitable quality for military rations.

References

1. Sapakie, S.F. and Renshaw, T.A., Economics of Drying and Concentration of Foods, Engineering and Food, vol. 2, Processing Applications, 927-937, 1984
2. Cohen, J.S., Rees, C., Hallberg, L., and Yang, T.C.S. Vegetable Drying in Two Novel Food Dryers, Technical Report NATICK/TR-94/027, U.S. Army Natick Research, Development and Engineering Center, Natick, MA, November 1994
3. Military Specification, Peas Dehydrated Compressed, MIL-P-43873A, U.S. Army Natick Research, Development and Engineering Center, Natick, MA, 30 June 1986
4. Sapakie, S.F., Mihalik, D.R., and Hallstrom, C.H. Drying in the Food Industry, Chem. Eng. Prog., 44-49, April 1979
5. Cohen, J.S., Yang, T.C.S., and Ayoub, J. Microwave-Augmented Freeze-Drying - Four Studies, Technical Report, NATICK/TR-94/017, U.S. Army Natick Research, Development and Engineering Center, Natick, MA April 1994 (AD A278 648)
6. Cohen, J.S. Personal Communication, June 30, 1994
7. Farkas, D.F., Lazarus, M.A. and Butterworth, T. The Centrifugal Fluidized Bed, 1. Flow and pressure relationships, Food Tech. 23: 1457, 1969
8. Cammarn, S.R., Lange, T.J. and Beckett, G.D. Continuous Fluidized Bed Roasting, Chem. Eng. Prog. 47-53, June 1990

APPENDIX A - Cost Comparisons

Operating Costs of Pilot Scale Equipment

The utility consumption of the pilot scale equipment was measured, from which the 1983 operating costs were calculated using the electricity and steam costs listed in Sapakie and Renshaw¹ and a cooling water cost of \$0.13 per 1,000 gallons (\$0.49 per cubic meter) as determined in Peters and Timmerhaus². These 1983 operating costs will be used later for comparison to Sapakie and Renshaw's calculation and for scale-up to 1994 costs. Electricity consumption for each piece of equipment was measured. Steam condensate was collected from the CF. Total condensation of the steam was assumed. The MW cooling water flow rate was also measured.

For the BD, approximately 85% of the electricity is consumed by the heater. This is an inefficient method of heating. Steam heating was calculated to be about 30% cheaper and is more likely to be used on a commercial scale. To calculate a more realistic operating cost for the BD, steam was assumed to provide 85% of the measured electrical load. The results are presented in Table A-1.

Table A-1 -1983 Utility Costs (Cents) for Drying 2 kg of Peas

Equipment Type	Total Utility Cost	Electricity Cost	Steam Cost	Water Cost	Drying Time Hours
BD	105	19	86	--	3 to 5
CF	139	57	82	--	2.0
MW @ 500 W	136	123	--	13	5.5
MW @ 250 W	198	179	--	19	7.0
MW @ 0 W	365	326	--	39	17.0

Electricity comprises the greatest percentage of the operating costs for the MW and least for the CF. The BD has the least operating costs while the MW and CF have the greatest. The trend in cost is closely related to the time required to dry the peas for the MW.

The power consumptions of the MW components were measured at the end of a run when power consumption was assumed to be at steady state. Instantaneous power readings were made using a digital wattmeter after each component was shut off. The results are shown in Table 15.

Table A-2 - MW Power Breakdown

<u>Component</u>	<u>Percent of Power Consumption</u>
Microwaves @ 250 W	9.5
Microwaves @ 500 W	7.9
Heating Platens @ 150 F (66 C)	1.6
Vacuum Pumps	28.6
Refrigeration Unit	50.8
Electronic Control Panel	1.6

From Table A-2, it can be seen that it is cheapest to run the MW at 500 W power. Although more power is being consumed at 500 W than at 250 W, the drying time is substantially reduced. Since the vacuum pumps and the refrigeration unit consume nearly 80% of the power, the shorter drying time at 500 W reduces the overall cost. While further savings could be achieved by operating at a greater power level, problems with arcing limit such a strategy to pilot scale equipment.

Microwave Augmented Freeze Dryer Cost Data

Costs for microwave power supplies were furnished by Microdry™, Inc. and are shown in Table A-3.

Table A-3 - Microwave Power Supply Costs

<u>Power Supply Capacity</u> <u>kW</u>	<u>Cost in 1994</u> <u>\$1,000</u>
6	20
10	23
15	30

Costs of Commercial Scale Equipment

Initially, it was attempted to estimate the capital cost of the pilot scale equipment at Natick and then scale up the costs to commercial scale using a power law. This approach was abandoned because of the difficulties and large uncertainties in estimating the cost of the pilot-scale equipment and the power law exponent. Instead, the estimates are based on Sapakie and Renshaw (1984), who directly estimate the cost of the commercial scale equipment.

The absolute values of the costs are not as significant as the relative values. For an estimate study, the absolute costs can be in error by as

much as 30%. Since the same assumptions and methods are used for all three technologies, the relative costs remain valid. Absolute fixed capital costs have an impact on relative manufacturing costs.

Fixed Cost Calculations

Sapakie and Renshaw (1984)¹ based their calculations on a mass balance around a generic dryer (Figure 7). They used the following hypothetical process conditions, which are similar to the conditions investigated in this study.

Table A-4 is a comparison of actual processing conditions for the peas to a hypothetical product.

Table A-4 - Comparison to Sapakie and Renshaw Processing Conditions

Physical Parameter	Hypothetical Product	Peas
Input Moisture, %	70	72
Input Specific Gravity	0.9	1.06
Heat Capacity (J/kg-°K)	3770	>4188 *
Output Moisture, %	5	ca 5
Output Specific Gravity	0.7	0.94

* The heat capacity of water at 25 C is 4,200. Assuming that solid peas have a lower heat capacity than water, the cited heat capacity seems reasonable.

The mass balance is based on a water removal rate of 1,000 lb (454 kg) per hour. The corresponding mass flows are shown in Figure A-1. The purchased capital costs were calculated as follows: (Sapakie and Renshaw (1984).

- 1) Establish inlet and outlet conditions.
- 2) Determine heat transfer coefficients and calculate energy balances.
- 3) Develop equipment list and size equipment.
- 4) Calculate purchased equipment cost.

The purchased capital cost was calculated for six different types of dryers: forced air, drum, fluidized bed, spray (SD), continuous vacuum and freeze (FD). The purchased capital costs were not verified in this study.

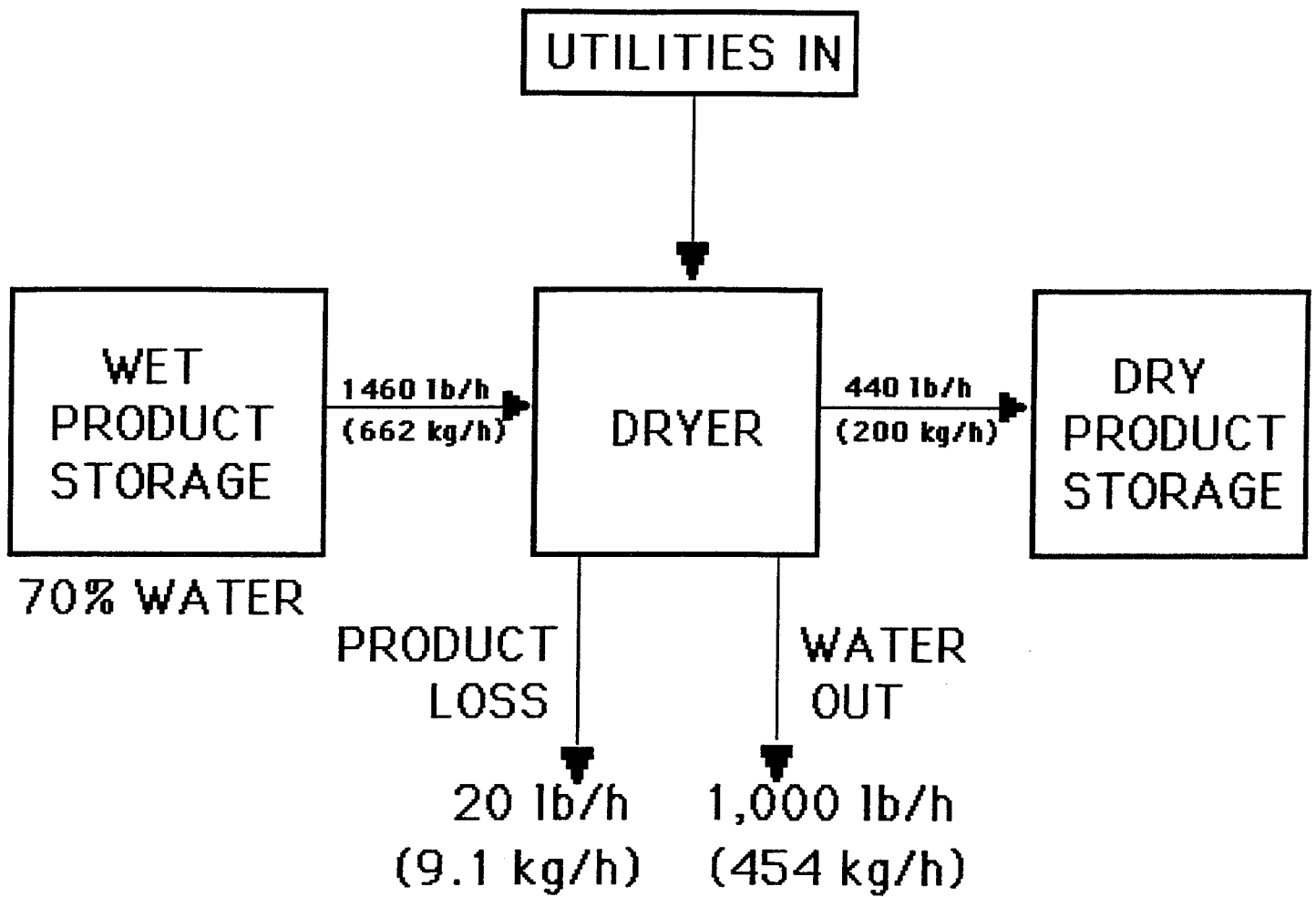

Basis: 1,000 lb/h (454 kg/h) water removed

FIGURE A-1 - HYPOTHETICAL DRYER

Using a basis of 100 for the purchased equipment, the total fixed cost as shown in Table A-5 are calculated as follows:

Table A-5 - Fixed Cost Calculations

Factor	Cost
Purchased Equipment	100
Installation	<u>40</u>
Total Direct Cost	140
Engineering	14 (10% of total direct cost)
Contingency	<u>21</u> (15% of total direct cost)
Total Fixed Cost	175

The total fixed cost assumes that the equipment will be installed into an existing facility with all service facilities, storage areas, etc. available. However, it is not clear whether instrumentation, controls, piping and electrical connections were included. For a solid-processing plant, these four items amount to about 35% of purchased equipment cost (Peter and Timmerhaus, 1991)² ..

The manufacturing cost calculations are shown in Table A-6.

Table A-6 - Manufacturing Cost Calculations *

Factor	Cost, dollars
Electricity	0.035 per kWh
Steam	6.000 per 1,000 lb (13.2 per 1,00 kg)
Natural Gas	6.060 per 100 ft ³ (0.172 per 100 m ³)
Labor	18.900 per h

Other assumptions in their calculations were:

Factor	Percent of Fixed Capital
Working Capital	15.0
Interest on Working Capital	15.0
Depreciation	15 year straight line
Taxes and Insurance	3.8
Maintenance and Supplies	6.0
Fixed Plant Overhead	75.0 (% of labor)
Plant Operation	250 days per year, 2 shifts per day, 7 hours per shift = 3500 hours per year

* Based on Sapakie and Renshaw, 1984 ¹

The percentages used for the fixed capital and manufacturing cost calculations agree with values in Peters and Timmerhaus (1991)².

The individual contributions to the total manufacturing costs were only listed for a SD with a water removal rate of 1,000 lb (454 kg) per hour. The above assumptions were used to reproduce the components of the manufacturing costs for the SD based on the listed fixed equipment cost.

The manufacturing costs were converted from dollars per year to cents per pound of water removed. (It is easier to compare the costs of the equipment with different capacities on this basis. All subsequent manufacturing costs will be expressed on that basis.)

The manufacturing costs for the SD could not be reproduced using the above assumptions. For the SD, the maintenance and supplies cost estimate was based on 2.45% of fixed capital (Sapakie and Renshaw, 1984). This study bases the estimate on 6%, the average reported by Peters and Timmerhaus (1991). Sapakie and Renshaw combined depreciation, taxes and insurance as well as interest on working capital into one category. Based on their assumptions, this cost could not be reproduced by the authors of this report. (\$1.57 per lb cf. \$1.50 per lb) (\$3.45 per kg cf. \$3.30 per lb). The labor cost used for the 1,000 lb (454 kg) per hour SD implied one operator per unit per shift.

In the next step, we attempted to reproduce the manufacturing costs for a 10,000 lb (4,540 kg) per hour SD, as well as two other types of dryers. Here, only the total manufacturing cost could serve as a check. For the calculations, maintenance and supplies costs were taken as 2.45% and overhead as 68.8% of fixed capital costs. (The other manufacturing costs can only be approximated because of the large uncertainty in the unknown labor and utility costs as well as the slight irreproducibility of depreciation, insurance, taxes and interest. It is not known whether Sapakie and Renshaw (1984) ¹ used their assumptions consistently in the calculations for each piece of equipment.

For the CF, the same labor requirements as for the SD were assumed (One operator per unit per shift). For the FD and MW, the labor requirements were doubled to account for the complexity of the equipment.

The labor requirements for the 10,000 lb (4,540 kg) per hour plants also had to be estimated. For the scaling of the labor requirement, the "one-fourth rule" was used (Popper, 1970)³. That approximation is that a ten-fold increase in capacity will double the labor requirement. Due to the per capacity basis of the manufacturing costs, doubling the labor

requirement has a relatively small effect on the cost for larger equipment.

Estimating the utility costs to reproduce Sapakie and Renshaw's manufacturing costs (1984) for the other dryers was difficult because the utility requirements are unknown for all the dryers.

For the hypothetical dryer (Figure A-1) a rough energy balance is established. If one assumes that all the energy is supplied by steam, this implies a reasonable efficiency of 70%. (For commercial SD and CF, the energy consumption for heating comprises the largest contribution to the total energy consumption., i.e. blowers and motors consume relatively little energy. Steam is most commonly used for heating.)

The United States Department of Agriculture (USDA) performed cost calculations for their PDS™ ball dryer (also a Model 25) in Gloucester, MA (used for drying fish). They based their estimate for the manufacturing costs of a BD, on the cost of a SD. According to the manufacturer of the BD, Ecal PDS™, the commercial scale BD requires 1,200 to 1,600 Btu per lb (2,790 to 3,720 kJ per kg) of water removed. The heat of vaporization of water is roughly 1,000 Btu (2,320 kJ) per lb. Using the median energy requirement of 1,400 Btu (3,250 kJ) this implies a 70% efficiency. This confirms the assumption of steam heating.

The USDA estimated that the utility costs of the SD are 26% higher than those of the BD. (A calculation for this difference was not cited. However, it is reasonable because of the better heat transfer in the BD.)

The utility cost for the FD was obtained indirectly from the BD utility cost. The ratio of the BD and the FD (MW at 0 watts) utility costs was used to find the freeze-dryer utility cost. The utility cost of the CF was assumed to be the same as the SD utility cost. The comparison is shown in Table A-7.

Table A-7 - 1983 Dryer Utility Costs

Factor	Type of Dryer			
	SD	BD	FD	CF
Ratio	1.00	0.87	3.19	1.00
Utility Cost, cents per lb (per kg)	1.10 (2.42)	n/a (n/a)	3.51 (7.37)	1.10 (2.42)

The utility costs were assumed to scale linearly with capacity.

The results of the manufacturing cost calculations for all three dryers at two capacities are shown in Table A-8. Sapakie and Renshaw, 1984¹, values are cited for comparison.

Table A-8 - 1983 Manufacturing Cost Summary

	Type of Dryer					
	SD		CF		FD	
Capacity, 1,000 lb per hour	1	10	1	10	1	10
Calculated	6.15	2.58	5.66	2.42	25.17	13.52
Sapakie and Renshaw	6.10	3.00	5.40	2.40	29.90	16.30

Given the number of approximations, these costs agree well with each other. The 1994 manufacturing costs for the BD, CF and MW could now be estimated.

For the BD, the supplier cited the 1994 cost for a commercial scale unit with a capacity of 500 kg (1,100 lb) per hour of water removal as \$725,000 FOB Swedish port. If a 25% surcharge is assumed for the delivery from international locations (Perry and Green, 1984)⁴, the delivered BD costs \$906,250 (1994). This is 60% greater than the cost of a SD updated to 1994 costs. This 60% increase was used to estimate the cost of the 10,000 lb (4,540 kg) per hour BD. Ecal PDS™ does not produce a BD with that capacity.

The fixed cost of the CF is assumed to be the same as that of the CF. The CF is expected to be more expensive, because it requires a rotating drying chamber. However, there was no basis to evaluate the cost increase. The fixed cost of the MW is estimated to be the same as the FD cost. The MW is actually more expensive because it is a FD with a microwave generator added.

The Marshall & Swift Equipment Cost Index™ was used to update the fixed costs from 1983 to 1994. The Hourly Earning Index for chemicals and allied products in Chemical Engineering Magazine was used to update the labor costs. Table A-9 lists the utility costs for 1994 (Peters and Timmerhaus, 1991)

Table A-9 - Utility Costs

Factor	Cost, Dollars
Electricity (per kWh)	0.035
Steam (per 1,000 lb) @100 psig	6.000
Steam (per 1,000 kg) @100 psig	13.210
Cooling Water (per 1,000 US gallons)	0.130
Cooling Water (per cubic meter)	0.034

The experimental utility costs were recalculated with these values. The commercial BD 1983 utility cost, calculated from the spray dryer utility cost with the USDA factor, was used as a basis to calculate the 1994 utility costs. The ratios of the 1994 experimental utilities cost were then used to determine the utilities costs for the commercial scale CF, MW and FD. The FD is presented for comparison. The utility costs are presented in Table A-10.

Table A-10 - 1994 Utility Costs

Cost	Type of Dryer			
	BD	CF	MW	FD
cents per lb water removed	0.82	1.40	2.04	5.74
cents per kg	1.80	3.08	4.49	12.63

The final cost results are presented in Table A-11.

Table A-11 - Overall Cost Summary, 1994

	Dryer							
	BD		CF		MW		FD	
Capacity	1	10	1	10	1	10	1	10
1,000 lb per hour	0.9	4.1	0.4	2.1	4.6	26.3	4.6	26.3
Fixed Costs (SMM)	9.4	3.8	7.3	3.2	34.1	17.6	37.8	21.3
Manufacturing Costs (cents per lb)								

In analyzing these costs, it must be remembered that the cost of the CF and MW are at the lower bound. The lower manufacturing costs for the 10,000 lb (4,540 kg) per hour plant indicate the economies of scale. The ten-fold increase in capacity decreased the costs by about 50%. The relative manufacturing costs at both capacities are shown in Table A-12.

Table A-12- Relative Manufacturing Costs

Ratio	Type of Dryer			
	BD	CF	MW	FD
	1.0	0.8	3.5 to 5.0	4.0 to 5.5

Manufacturing Cost Calculations

Economic calculations are usually based on the cost per pound of water removed, as this facilitates cost calculations for products with different moisture contents. To compare the cost of a particular product, it is more meaningful to express the cost on a dried product basis.

The drying costs for the BD, CF, MW and FD at a 1,000 lb (454 kg) per hour capacity are shown in Table 19. These costs are equivalent to 32, 25, 116 and 129 cents per lb (70, 55, 255 and 284 cents per kg) of dry product respectively. For these calculations, it was assumed that the moisture content was reduced from 78 to 3%.

The Army purchases peas for \$184.35 per case which corresponds to \$6.47 per lb (\$14.23 per kg) of dry peas. This includes the procurement cost and all processing costs (freeze drying, rehydrating, compressing, freeze drying of the compressed product, and canning). When compared to the drying costs of the freeze dryer, the savings for the CF, BD and MW are \$5.50, \$5.43 and \$6.34 per lb (\$11.55, \$11.95 and \$13.95 per kg) of dry product. These amount to overall savings of 15, 16 and 2% over the current manufacturing costs. Thus, switching to any one of these technologies will result in a more cost-effective process.

The Army currently purchases 950 cases of 24 No. 2.5 cans of peas. The plant would have to operate for 5 days per year (based on a drying capacity of 1,000 lb (454 kg) of water per hour) to dry the peas. The plant can be used to dry other food products for the remaining 245 working days of the year.

The cost calculations are summarized in Tables A-13 and A-14.

The tables are based on the following assumptions:

Marshall and Swift Equipment Cost Index

(1926 = 100; 1983, 1st Q = 751.0; 1994, 1st Q = 980.3

Hourly Earning Index, chemicals and allied products, Chem. Eng. J.

1967 = 100; 1st Q '83 = 334.5/1.675/1.9224 = 104.86, Feb. '94 = 121.9

MS Index Ratio: 1.31

Labor Index Ratio: 1.16

Labor Cost, \$/hr (1983): 18.90

Labor Cost, \$/hr (1994): 21.96

Assumptions for Manufacturing Costs

Working Capital, % of Fixed Costs: 15

Straight Years: 15

Interest, % of Capital: 15

The cost comparison data are illustrated in Figures A-2 to A-4.

Figure A-2 is a comparison of the fixed and variable costs for each dryer for capacities of both 1,000 and 10,000 lb water removed per hour. The much higher fixed costs for the MW and FD (same equipment) reflect the higher cost of the equipment. Figure A-3 is a breakdown of all the variable costs. Maintenance, depreciation, interest and taxes and insurance are all based on a fixed percentage of the fixed costs. Because of that, Figure A-4 shows the variable costs of only utilities, labor and overhead. Overhead costs are a percentage of labor costs. This figure shows the much greater utility costs of the freeze dryer. Figures A-3 and A-4 are both based on 10,000 lb water removed per hour.

References

1. Sapakie, S.F. and Renshaw, T.A. Economics of Drying and Concentration of Foods, Engineering and Food, vol. 2, Processing Applications, 927-937, 1984
2. Peters, R.H. and Timmerhaus, K.D. Plant Design and Economics for Chemical Engineers, McGraw-Hill, New York, NY 1991
3. Popper, H. ed., Modern Cost Engineering Techniques, McGraw-Hill, New York, NY 1970
4. Per, R.H. and Green, D. Perry's Chemical Engineer's Handbook, 6th ed., McGraw-Hill, New York, NY 1984

Table A-13 - 1983 Cost Calculations

Factor	Type of Dryer					
	SD		CF		FD	
Capacity in lb H ₂ O/hr	1,000	10,000	1,000	10,000	1,000	10,000
Fixed Cost \$000	429	1950	315	1575	3528	20160
¢/lb H ₂ O removed	12.26	5.57	9.00	4.50	100.80	57.60
Working Capital, 15%	1.84	0.84	1.35	0.68	15.12	8.64
Labor Cost \$/hr	18.90	18.90	18.90	18.90	18.90	18.90
People	1	2	1	2	2	4
Straight years	15	15	15	15	15	15
Interest, %	15	15	15	15	15	15
Manufacturing Cost Summary						
Labor ¢/lb H ₂ O removed	1.89	0.38	1.89	0.38	3.78	0.76
Overhead, 68.8%	1.30	0.26	1.30	0.26	2.60	0.52
Maintenance/ Supply, 2.45%	0.30	0.14	0.22	0.11	2.47	1.41
Depreciation	0.82	0.37	0.60	0.30	6.72	3.84
Taxes/Insurance	0.47	0.21	0.34	0.17	3.83	2.19
Interest on Working Capital	0.28	0.13	0.20	0.10	2.27	1.30
Utilities	1.10	1.10	1.10	1.10	3.50	3.50
TOTAL	6.15	2.58	5.66	2.42	25.17	13.52
Comparison with Sapakie and Renshaw	6.10	3.00	5.40	2.40	29.90	16.30

Table A-14 - 1994 Cost Calculations

Factor	Type of Dryer							
	BD		CF		MW *		FD	
Capacity in 1,000 lb H ₂ O/hr	1	10	1	10	1	10	1	10
Fixed Cost, \$000 (1983)			315	1575	3528	20160	3528	20160
Fixed Cost, \$000 (1994)	906	4123	411	1056	4605	26315	4605	26315
¢/lb H ₂ O removed	25.89	11.78	11.75	5.87	131.57	75.19	131.57	75.19
Manufacturing Cost Summary								
Workers/unit/shift	1	2	1	2	2	4	2	4
Utilities, 1983	0.96	0.96	1.27	1.27	1.24	1.24	3.50	3.50
Utility Factor for 1994	0.86	0.86	1.10	1.10	1.64	1.64	1.64	1.64
Labor ¢/lb H ₂ O	2.20	0.44	2.20	0.44	4.39	0.88	4.39	0.88
Overhead, 70%	1.54	0.31	1.54	0.31	3.07	0.61	3.07	0.61
Maintenance/ Supply, 6%	1.55	0.71	0.70	0.35	7.89	4.51	7.89	4.51
Depreciation	1.73	0.79	0.78	0.39	8.77	5.01	8.77	5.01
Taxes/Insurance	0.98	0.45	0.45	0.22	5.00	2.86	5.00	2.86
Interest on Working Capital	0.58	0.27	0.26	0.13	2.96	1.69	2.96	1.69
Utilities, 1994	0.82	0.82	1.40	1.40	2.04	2.04	5.74	5.74
TOTAL	9.40	3.77	7.33	3.25	34.13	17.61	37.84	21.3

* same fixed costs as FD

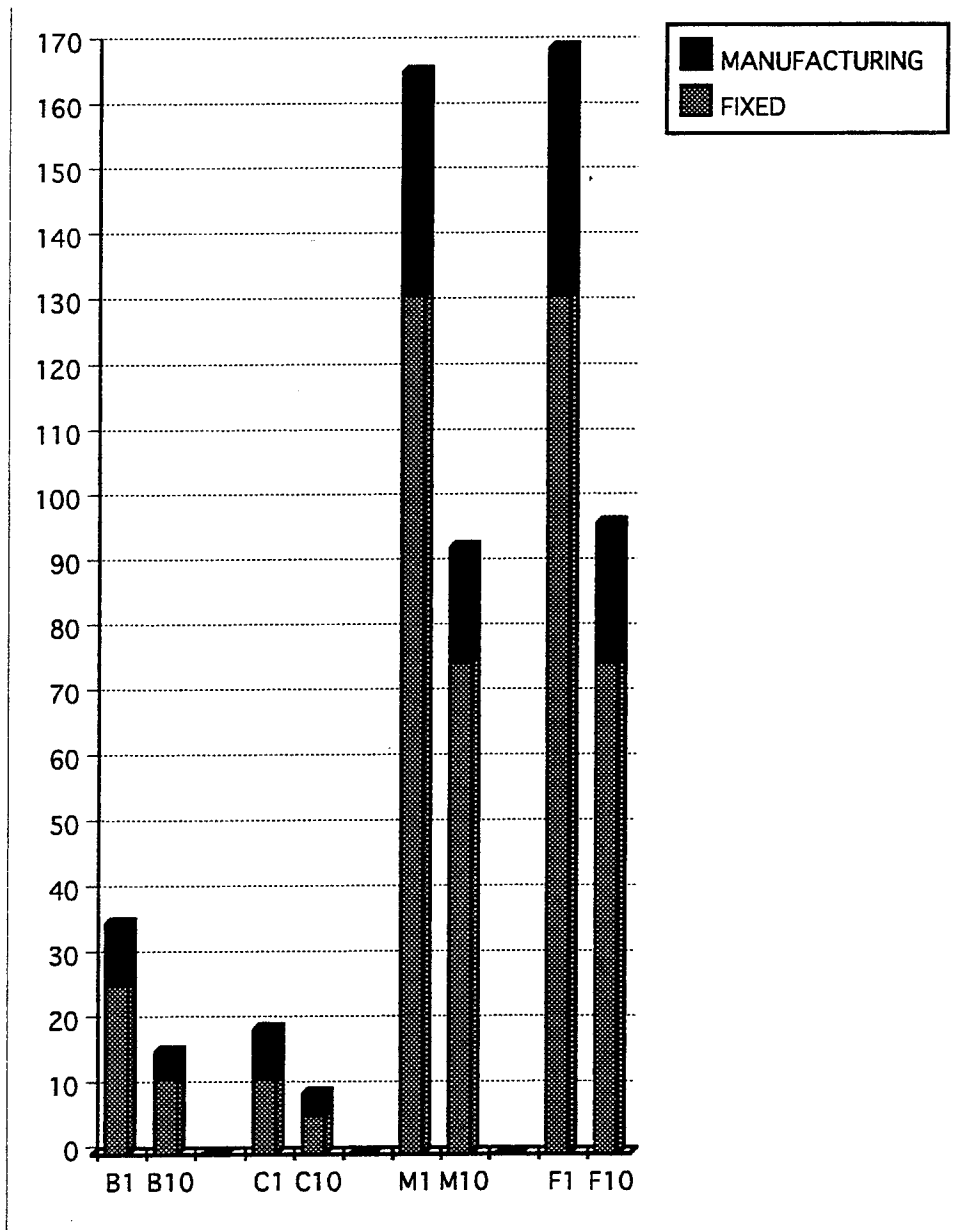

FIGURE A-2 - COST COMPARISON OF DRYERS, FIXED AND VARIABLE COSTS

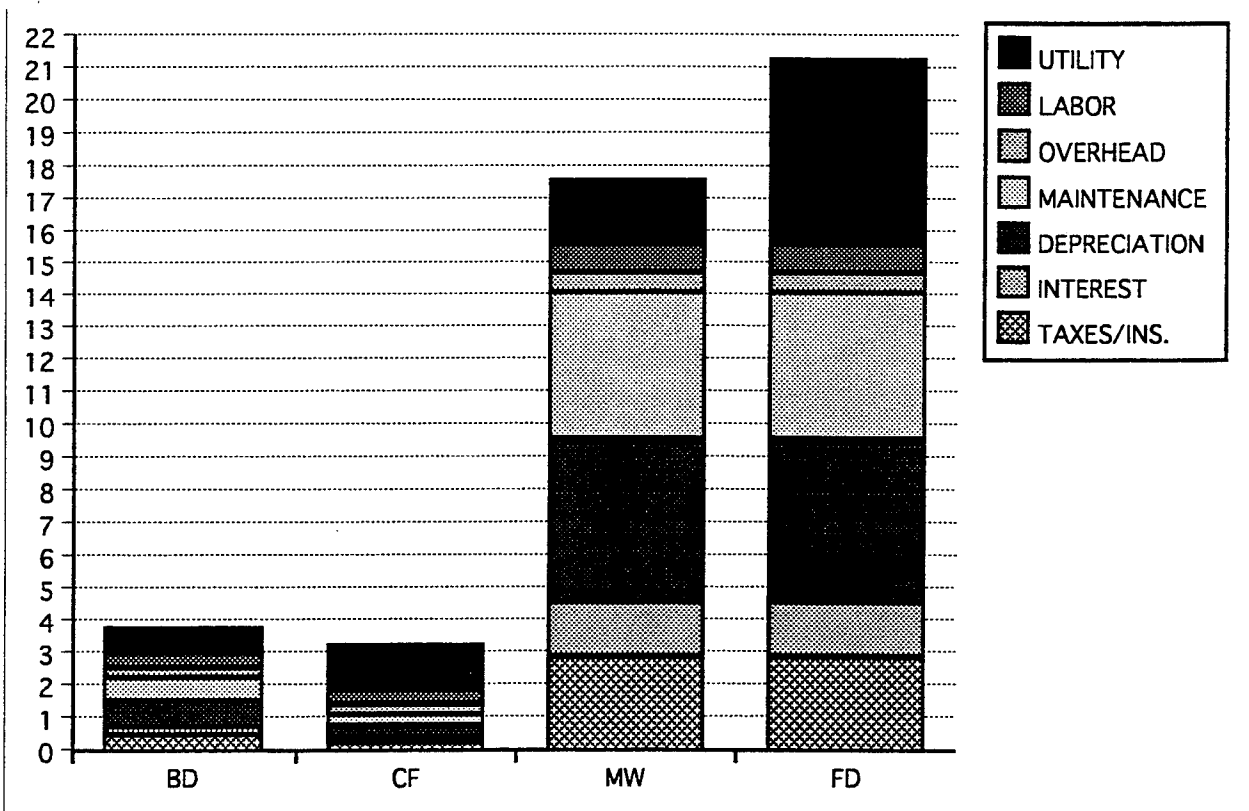

FIGURE A-3 - COST COMPARISON OF DRYERS, VARIABLE COSTS

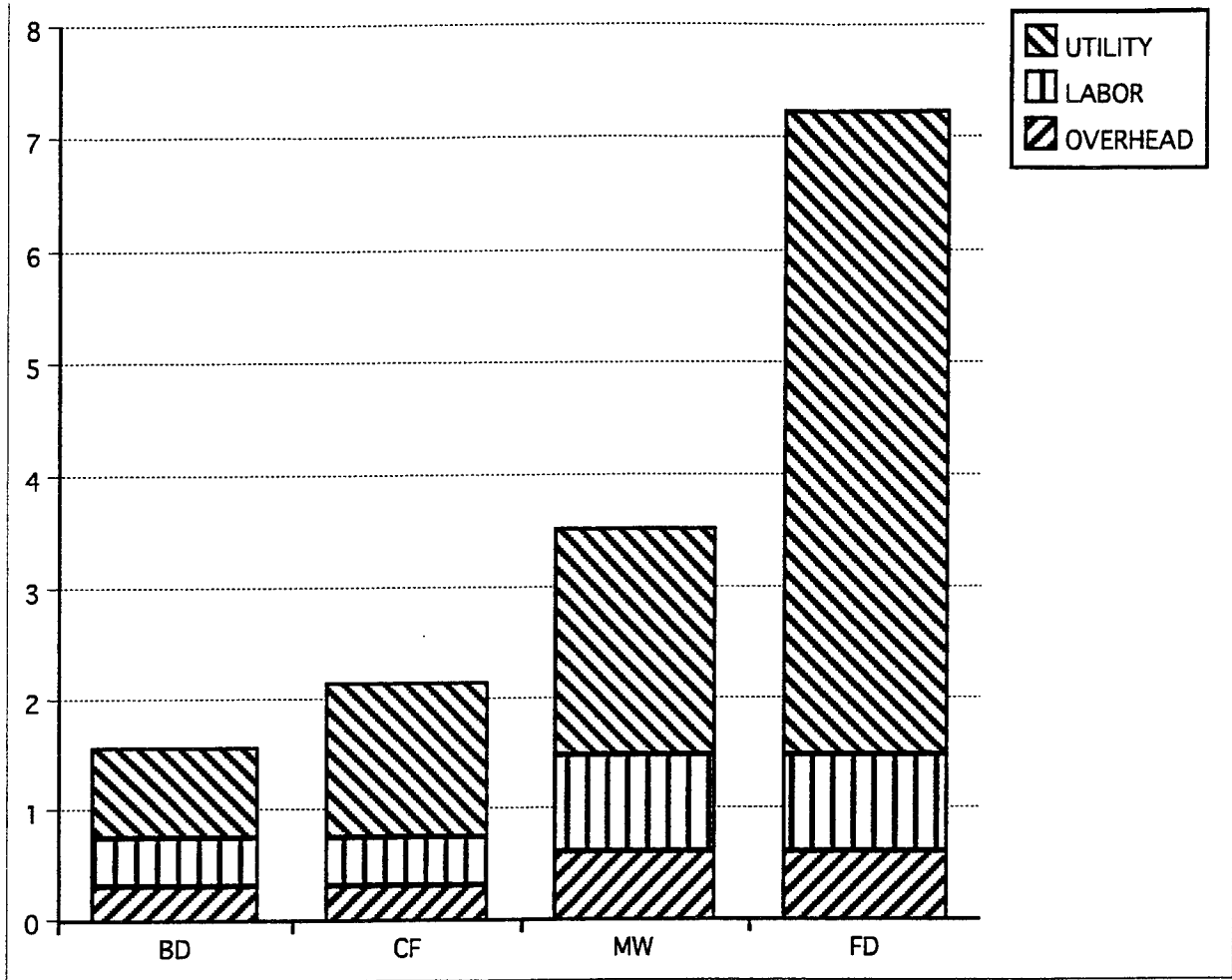

FIGURE A-4 - COST COMPARISON OF DRYERS, SELECTED VARIABLE COSTS

APPENDIX B - Additional Results and Discussion

Ball Dryer: Comparison of Previous and Current Moisture Results

The final moisture values from runs 6 and 7 do not agree with previous experiments by Cohen, Rees, Hallberg and Yang (1994).¹ The interior cylinder speed was 1.2 rpm for both experiments. The inlet temperature for the Cohen experiments was 180 F (82 C) as compared to 220 F (104 C) for the current experiments. The Cohen work obtained moisture values of 5 to 13% as compared to approximately 20% in the recent experiments. The higher inlet air temperature of the recent experiments should have resulted in a lesser moisture level.

The ambient relative humidity during run 7 of the current experiments was 65%. The other current experiments were also performed on humid days. The Cohen experiments were performed in April, 1994, when the weather was cooler and less humid. The humidity was not measured at that time but it can be assumed to be less than 65%.

The relative humidity of the exhaust air for run 7 was 20%. The wet bulb temperature (and therefore the relative humidity) could only be measured after some mixing had taken place with the air of the exhaust pipe. The dry bulb temperature inside the exhaust pipe was about 180 F (82 C). From the ambient and exhaust pipe outlet temperatures as well as the temperature inside the exhaust pipe, an energy balance can be established and the relative air flow rates can be determined. Since the absolute moisture level of the ambient air and the exhaust pipe outlet air are about the same (0.013 kg water per kg air), the closure of the mass balance requires the absolute moisture inside the exhaust pipe to be about the same. This constraint implies that the absolute moisture does not increase significantly as the air passes through the dryer, i.e. it does not pick up much moisture from the peas. This conclusion was confirmed by calculations, which indicated that during a run 1,800 kg (36,400 lb) of air picked up 1.45 kg (3.2 lb) of water. i.e. 0.00081 kg water per kg air. This is an insignificant addition to an absolute moisture level of about 0.013 kg water per kg air, about 6%.

From the absolute humidity and the dry bulb temperature, the relative humidity within the exhaust pipe is 4%. The relative humidity dropped because the temperature of the air within the exhaust pipe was 100 F (56 C) greater than the ambient temperature. This increase in the absolute humidity of the air and therefore the relative humidity throughout the

the drying chamber can be assumed to be about 4%. (It would be somewhat lower at the inlet of the drying chamber where the temperature is close to 220 F (121 C).) The driving force for the drying process is proportional to the partial pressure difference between the water on the surface of the pea and the water in the air. The proportionality constant is the external mass transfer coefficient for the transport from the surface to the bulk air. There is also an internal mass transfer coefficient for the transport of moisture within the pea. During the early stages of drying, the mass transfer to the surface of the pea takes place readily. The surface resistance to evaporation of the pea shell primarily controls the drying rate. During the later stages of drying, the moisture gradient is smaller and the internal transfer resistance is controlling the transport of moisture. Hence, an increase in the drying potential of the air by increasing the wet-bulb depression (the difference between wet-bulb and dry-bulb temperature) has no significant effect on the drying rate.

It can be concluded that the lower ambient humidity during the experiments by Cohen, Hallberg and Yang (1994) had an insignificant effect on drying. Several other reasons could explain the difference of the moisture levels between the current and earlier experiments. First, the reproducibility of the earlier experiments is not as good as that of the present experiments. For the same operating conditions they obtained 5.8 and 13.5% final moistures, while we obtained 19.9 and 19.3% values. Secondly, they used peas from a different supplier. Thirdly they measured the moisture at about the mid-point of each run, whereas we took the measurements after completion of each run. When combined, these effects can account for the differences in the results.

Effect of Feeder on Ball Dryer Quality

The effect of the type of feeder on the product quality was investigated because the screw conveyor seemed to destroy too many peas. These results are shown in Table B-1. The reported values are the means of four measurements, except for the rehydration ratio which is the average of two measurements.

Table B-1 - Effect of Feed Type on Ball Dryer

Run No.	Feed Type	"L"	"a"	"b"	Rehyd. Ratio	Peak Force, N	Work, Nm
2	batch	26.9	-4.03	11.2	1.00	59.0	0.448
3	batch *	27.9	-5.69	11.8	0.95	71.4	0.524
6	screw	27.4	-6.30	11.6	1.07	49.7	0.429
7	screw	28.9	-6.86	12.6	1.16	53.0	0.442
control	n/a	33.0	-8.97	14.4	n/a	60.0	0.403

* This run is at a rotation rate of 0.75 rpm. All others at 1.2 rpm.

The negative impact of the screw conveyor on product quality was partially offset by selecting less damaged peas for the quality measurements. (Refer to the section on BD equipment performance for more detail.)

A comparison of the quality measurements of peas dried at the same operating conditions but with different feeding techniques indicates that the quality of the screw conveyor-fed peas (runs 6 and 7) is not significantly different from the batch-fed (run 2) peas, except for the greenness. The screw-fed were greener (closer to the control value) than the batch-fed. The accuracy of the greenness measurement of the batch-fed peas is questionable because run 3 (with the same feeding technique but a longer residence time and therefore, a lower moisture content) produced peas of better quality. It is expected that with increasing extent of drying the quality of a rehydrated product either decreases or remains unchanged, but never improves. The run 3 quality results are expected to be more accurate because they are in better agreement with the other measurements.

The difference in the texture measurements is not meaningful because only non-damaged peas were selected for these measurements. Rather, the difference is an indication of the weak reproducibility of the texture measurements.

There could have been a difference in quality because the run 2 peas were stored longer than the run 6 and 7 peas. At a moisture content of about 20%, degradation of the product can take place even when the product is frozen.

While these measurements do not indicate a significant difference between the feeding techniques, nevertheless, about 50% of the screw-fed peas were damaged. This is clearly unacceptable.

Other Ball Dryer Problems

The basket separating the peas from the polyester balls broke during one run. This was noticed because fewer peas than usual were collected after completion of the regular run time. Polyester balls fell into the exhaust pipe and clogged the flow of peas into the cyclone.

Reference

1. Cohen, J.S., Rees, C., Hallberg, L., and Yang, T.C.S. Vegetable Drying in Two Novel Food Dryers, Technical Report NATICK/TR-94/027, U.S. Army Natick Research, Development and Engineering Center, Natick, MA, November 1994

APPENDIX C - Recommendations

Recommendations for Commercial Equipment Installation

The first step in the current processing sequence is to freeze dry the peas to 3% moisture to eliminate the ice core left by surface heating at greater moisture levels. Surface heating leaves the peas dry and brittle. Subsequently the dried peas are rehydrated to 20% moisture to make them more pliable, and are then compressed into discs. These discs are dried to 3% moisture to obtain the required shelf stability of three years. This sequence and options for its improvement are shown schematically in Figure C-1..

One option is to follow the above sequence using a MW instead of a FD. There would be savings in the utility costs, although these may be offset by greater capital costs.

It may be possible to eliminate the rehydration step. Since the microwaves heat an individual pea more uniformly, there would not be any ice core at 20% moisture. Therefore, the peas could be dried in a MW to 20% moisture, followed by compression and final drying. The pliability of the peas at 20% moisture obtained from MW must still be verified. Eliminating the rehydration step, and thereby drying the peas to 3% only once, will reduce the processing costs.

Alternatively, the frozen peas can be dried in a BD or CF to 20% moisture levels. These peas are not brittle and therefore are compressible. The compressed peas must be dried in a MW because the CF or BD would damage the discs.

If the quality of the peas from this process is not satisfactory, a BD or CF could be used to dry the peas to an intermediate moisture level (30 to 50%) before significant quality degradation begins. The peas could then be dried to 20% in a MW followed by compression and final drying.

Substituting the MW with a BD or CF reduces the cost of the first drying step. However, this requires adding a second type of dryer. This would increase the capital cost if the drying requirements of the plant could be met with a single dryer.

For each operating strategy, the quality of the peas should be assessed by a sensory panel. An economic analysis incorporating all processing steps should be conducted. The trade-off between product cost and quality should be resolved. Only then should an option be selected and implemented.

Present:

78% Freeze → 3% Rehyd. → 20% Compress Discs Freeze → 3%

Options:

MW instead of freeze dryer

78% MW → 20% Compress Discs MW → 3%
BD/CF

78% BD/CF → 30-50% MW → 20% Compress Discs MW → 3%

FIGURE C-1 - NEW DRYING STRATEGIES

Recommended Operating Conditions for Each Pilot Equipment

These operating conditions are recommended for the production of the best quality product at the pilot scale,

For the BD:

1. Inner cylinder rotation rate: 1.2 rpm
2. Inlet air temperature: 170 F (77 C)
3. Feedrate: 20%

For the CF:

1. Rotation rate: 60 rpm
2. Air temperature 122 F (50 C)
3. Air flowrate: 15 cfs (0.43 cubic meters per sec)

For the MW:

1. Microwave power: 500 W
2. Bottom platen temperature: 150 F (66 C)

Recommendations for Improvement of Pilot Scale Equipment

Peas dried using the different technologies should be evaluated by a sensory panel.

The temperature at which all future moisture measurements are made with the Computrac™ analyzer should be at 212 F (100 C) or less to improve accuracy. This applies not only to peas, but to other vegetables as well.

Ball Dryer

The BD should be run at an inlet temperature of approximately 170 F (77 C) to ensure good product quality. Temperatures above 212 F (100 C) should be avoided.

The size of the drying chamber should be carefully re-designed so that the desired moisture level can be achieved. Alternatively, more than one BD can be run in series.

The screw conveyor can be improved in several ways. The distance between the screw and the circular casing at the bottom of the feeder is too large, allowing peas to be squeezed through this gap. Small holes should be drilled in the bottom of the feeder to allow water from the defrosted peas to drain. The peas should still be fed frozen as this way

fewer will be damaged. Another improvement is to reduce the distance between the windings of the screw. Currently, this distance is almost two pea diameters. The friction on the edges of the winding creates a shear force between the peas which damages them. If the distance is reduced to just slightly more than one pea diameter, 1 cm (0.4 in), this shear will be minimized, but the reduction would limit the size of items that could be dried.

Centrifugal Fluidized Bed Dryer

To improve the CF product quality, it is necessary to obtain better fluidization. The air flow rate must be increased to achieve this. This can be done by installing a larger blower.

The problem of peas sticking to the centrifuge wall can be eliminated by running the equipment at lower rotation rates, at least during the beginning of the run when the peas are soft and moist.

Temperatures of over 80 C (176 F) can reduce the moisture content further at the expense of overall quality.

The heater should have a variable heat duty so that only the required amount of air is heated and none is wasted. (Refer to the equipment performance section for details.) This scheme will also reduce the total energy consumption.

Microwave Augmented Freeze Dryer

Solutions to the arcing problem in the MW should be investigated. The chamber might be coated with a non-reflective material. It is important to determine the optimum microwave power level for both the pilot and commercial scale equipment.

None of the microwave power levels studied had a significant effect on product quality. The maximum power level attainable prior to the onset of quality degradation should be determined.

The distance from the rotating MW sample tray to the platen should be minimized to enhance the effect of radiant heat transfer on drying.

The MW could be equipped with multiple rotating trays with individual platens for each tray to increase the dryer capacity.

APPENDIX D - SAMPLE CALCULATIONS

Microwave Augmented Freeze Dryer

Determination of Cooling Water Flow Rate

The amount of time to fill a 3 liter (0.79 gal.) can with the cooling water was an average of 15.7 seconds. This gave a flow rate of 11.5 liters (3.0 gal.) per minute.

Sample CF Run Cost Calculation

The utility costs for the three dryers were calculated in a similar manner. A sample CF run calculation is presented below. The data are from a run conducted at 176 F (80 C) air temperature and a drum rotation rate of 150 rpm.

Electricity:

Initial wattmeter reading: 08539
Wattmeter reading after reheating: 08540
Final wattmeter reading: 08554
Electricity consumed: $08554 - 08539 = 15$ kWh
Cost of one kWh: 6.0 cents
Cost of electricity: $(0.06)(15) = \$0.90$

Steam:

Condensed steam was collected in a bucket at the beginning, in the middle and towards the end of the run. It was assumed that the 100 psig steam was condensing fully.

Table D-1 illustrates the data thus collected.

Table D-1 - Steam Flow Rate

Portion of Run	Collection Time, min.	Condensate Collected, g	Condensate Flow Rate g per min
Initial	6	4,280	713
Middle	10	4,030	403
Final	10	3,970	397

It was observed that more steam was being consumed during the beginning of the run. The total steam consumption was estimated by:

$$\begin{aligned} \text{Total steam} &= 30 \text{ (Initial rate)} + 90 \text{ (Average of final and middle rates)} \\ &= 57.39 \text{ kg} \end{aligned}$$

In these calculations, the steam used for the initial preheating was neglected.

$$\text{Cost of steam} = \$4 \text{ per 1,000 lb } (\$8.80 \text{ per 1,000 kg})$$

$$\text{Total steam cost} = (\text{steam consumed}) (\text{unit cost of steam}) = \$0.52$$

$$\text{Operational cost of run} = \text{steam cost} + \text{electricity cost} = \$1.42$$

Minimum Fluidization and Terminal Velocity Calculations

These calculations were done for a run with an air temperature of 80°C (176 F) and a rotation rate of 150 rpm.

$$\text{Density of air } (\rho_a) = 1.19 \text{ kg per cubic meter}$$

$$\text{Viscosity of air } (\mu) = 0.00002 \text{ kg per m per s}$$

$$\text{Kinematic viscosity } (\nu) = 0.0000168 \text{ m}^2 \text{ per s}$$

$$\text{Acceleration due to gravity } (g) = 9.8 \text{ m per s}^2$$

$$\text{Density of frozen peas (78\% moisture)} (\rho_1) = 1,065 \text{ kg per m}^3$$

$$\text{Density of dried peas (7\% moisture)} (\rho_2) = 938 \text{ kg per m}^3$$

$$\text{Diameter of frozen peas } (d_{p1}) = 0.00933 \text{ m}$$

$$\text{Diameter of dried peas } (d_{p2}) = 0.00635 \text{ m}$$

Goroshko-Rosenbaum-Todes Relationship:

$$\text{Remf} = \text{Ar}' / [K + L * (\text{Ar}')^2] \quad (1)$$

Wen and Yu Correlation:

$$\text{Remf} = [(33.7)^2 + (0.048) \text{Ar}'^{0.5}] - 33.7 \quad (2)$$

$$\text{Terminal Velocity } (V_t) \quad (3)$$

$$V_t = [(F_c) (g)(d_p)(d - d_a)]^{0.5}$$

Where Ar' = Archimedes Number modified for effect of centrifugal force

$$= (d_p^3) [(g)(F_c)(d - d_a)] / [(d_a)(\nu^2)] \quad (4)$$

F_c = Centrifugal force applied on a particle in multiple of gravity = $[(r)(\omega)^2] / g \quad (5)$

r = radius of drum = 6 in (-0.152 m)

ω = angular velocity of drum = 6.28 (rpm)

$$K = [150 (1 - E)/E^3] \quad (6)$$

$$E = \text{voidage} = 0.4 \text{ (assumed)}$$

$$L = 0.5 (1.75)/E^3 \quad (7)$$

$$\text{Remf} = \text{Reynolds Number at vmf} =$$

$$[(d_p)(\text{vmf})(\rho_a)]/\mu \quad (8)$$

$$\text{vmf} = \text{Air velocity at minimum fluidization (m/s)}$$

$$v_t = \text{Terminal velocity}$$

Number of Operating Days for the Plant

Capacity of plant: 1,000 lb (454 kg) of water removed per hour

Present Demand: 950 Cases of No. 2.5 cans per year

No. of cans per case: 24

Mass of dried peas in one can: 19 oz. = 1.19 lb = 0.54 kg

Mass of peas to be supplied in one year = 27,000 lb = 12,260 kg

Mass of water to be removed from peas = 66,600 lb = 30,200 kg *

* moisture reduced to 3% from 72%

Operating time of the plant: 66.6 hours

Working time in one day = (No. of shifts) (Duration of shift) = (2)(7) = 14

No. of operating days per year = 66.6/14 = 5