



**US Army Corps
of Engineers**

Construction Engineering
Research Laboratories

USACERL Technical Report FM-94/16
September 1994

Off-Potential Measurement Systems for Impressed Current Cathodic Protection

by
Vincent F. Hock
Lewis F. Setliff
Wesley A. Houtz
Michael Noble
Brad J. Lewis
Malcolm E. McLeod

The Army currently maintains more than 20,000 underground storage tanks, over 3000 miles of buried pipeline, and more than 300 elevated water storage tanks, all requiring some form of corrosion control. Impressed current, cathodic protection (CP) systems are a widely used form of corrosion control for these structures. These CP systems contain numerous components that are susceptible to failure if not installed or maintained correctly. To ensure corrosion protection for a structure, the performance of a CP system must be determined in the field.

This study investigated off-potential measurement systems for impressed current CP systems in the laboratory and in the field. Commercially available off-potential measurement devices were investigated to test their reliability in recording off-potentials, which define the effectiveness of a CP system. Off-potential measurement devices were found to provide accurate system performance data.

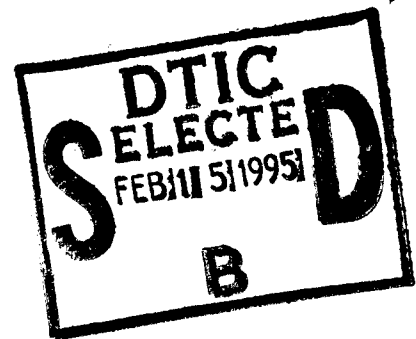

19950206 199

The contents of this report are not to be used for advertising, publication, or promotional purposes. Citation of trade names does not constitute an official endorsement or approval of the use of such commercial products. The findings of this report are not to be construed as an official Department of the Army position, unless so designated by other authorized documents.

DESTROY THIS REPORT WHEN IT IS NO LONGER NEEDED

DO NOT RETURN IT TO THE ORIGINATOR

USER EVALUATION OF REPORT

REFERENCE: USACERL Technical Report FM-94/16, *Off-Potential Measurement Systems for Impressed Current Cathodic Protection*

Please take a few minutes to answer the questions below, tear out this sheet, and return it to USACERL. As user of this report, your customer comments will provide USACERL with information essential for improving future reports.

1. Does this report satisfy a need? (Comment on purpose, related project, or other area of interest for which report will be used.)

2. How, specifically, is the report being used? (Information source, design data or procedure, management procedure, source of ideas, etc.)

3. Has the information in this report led to any quantitative savings as far as manhours/contract dollars saved, operating costs avoided, efficiencies achieved, etc.? If so, please elaborate.

4. What is your evaluation of this report in the following areas?

a. Presentation: _____

b. Completeness: _____

c. Easy to Understand: _____

d. Easy to Implement: _____

e. Adequate Reference Material: _____

f. Relates to Area of Interest: _____

g. Did the report meet your expectations? _____

h. Does the report raise unanswered questions? _____

i. General Comments. (Indicate what you think should be changed to make this report and future reports of this type more responsive to your needs, more usable, improve readability, etc.)

5. If you would like to be contacted by the personnel who prepared this report to raise specific questions or discuss the topic, please fill in the following information.

Name: _____

Telephone Number: _____

Organization Address: _____

6. Please mail the completed form to:

Department of the Army
CONSTRUCTION ENGINEERING RESEARCH LABORATORIES
ATTN: CECER-IMT
P.O. Box 9005
Champaign, IL 61826-9005

REPORT DOCUMENTATION PAGE

Form Approved
OMB No. 0704-0188

Public reporting burden for this collection of information is estimated to average 1 hour per response, including the time for reviewing instructions, searching existing data sources, gathering and maintaining the data needed, and completing and reviewing the collection of information. Send comments regarding this burden estimate or any other aspect of this collection of information, including suggestions for reducing this burden, to Washington Headquarters Services, Directorate for Information Operations and Reports, 1215 Jefferson Davis Highway, Suite 1204, Arlington, VA 22202-4302, and to the Office of Management and Budget, Paperwork Reduction Project (0704-0188), Washington, DC 20503.

1. AGENCY USE ONLY (Leave Blank) 2. REPORT DATE
September 1994 3. REPORT TYPE AND DATES COVERED
Final

4. TITLE AND SUBTITLE
Off-Potential Measurement Systems for Impressed Current Cathodic Protection 5. FUNDING NUMBERS
4A162784
AT41
MA-CM2

6. AUTHOR(S)
Vincent F. Hock, Lewis F. Setliff, Wesley A. Houtz, Michael Noble, Brad J. Lewis, Malcolm E. McLeod

7. PERFORMING ORGANIZATION NAME(S) AND ADDRESS(ES)
U.S. Army Construction Engineering Research Laboratories (USACERL)
P.O. Box 9005
Champaign, IL 61826-9005 8. PERFORMING ORGANIZATION
REPORT NUMBER
FM-94/16

9. SPONSORING / MONITORING AGENCY NAME(S) AND ADDRESS(ES)
Commander, Headquarters, U.S. Army Corps of Engineers
ATTN: CECPW-ES
20 Massachusetts Avenue, NW.
Washington, D.C. 20314-1000 10. SPONSORING / MONITORING
AGENCY REPORT NUMBER

11. SUPPLEMENTARY NOTES
Copies are available from the National Technical Information Service, 5285 Port Royal Road, Springfield, VA 22161.

12a. DISTRIBUTION / AVAILABILITY STATEMENT
Approved for public release; distribution is unlimited. 12b. DISTRIBUTION CODE

13. ABSTRACT (Maximum 200 words)
The Army currently maintains more than 20,000 underground storage tanks, over 3000 miles of buried pipeline, and more than 300 elevated water storage tanks, all requiring some form of corrosion control. Impressed current, cathodic protection (CP) systems are a widely used form of corrosion control for these structures. These CP systems contain numerous components that are susceptible to failure if not installed or maintained correctly. To ensure corrosion protection for a structure, the performance of a CP system must be determined in the field.
This study investigated off-potential measurement systems for impressed current CP systems in the laboratory and in the field. Commercially available off-potential measurement devices were investigated to test their reliability in recording off-potentials, which define the effectiveness of a CP system. Off-potential measurement devices were found to provide accurate system performance data.

14. SUBJECT TERMS
cathodic protection underground storage tanks
ceramic anode
corrosion mitigation 15. NUMBER OF PAGES
74 16. PRICE CODE

17. SECURITY CLASSIFICATION OF REPORT
Unclassified 18. SECURITY CLASSIFICATION OF THIS PAGE
Unclassified 19. SECURITY CLASSIFICATION OF ABSTRACT
Unclassified 20. LIMITATION OF ABSTRACT
SAR

Foreword

This study was conducted for Directorate of Military Programs, Headquarters, U.S. Army Corps of Engineers (HQUSACE) under Project 4A162784AT41, "Military Facilities Engineering Technology"; Work Unit MA-CM2, "Low Maintenance Cathodic Protection Systems." The technical monitors were Malcolm McLeod, CECPW-ES and G. Evans, CEMP-ET

The work was performed by the Engineering and Materials Division (FM) of the Infrastructure Laboratory (FL), U.S. Army Construction Engineering Research Laboratories (USACERL). Appreciation is expressed to Malcolm McLeod, Branch Chief of the Sanitary and Chemical Branch, U.S. Army Center for Public Works (USACPW). Technical assistance was provided by Roch Ducey, of the Energy and Utilities Systems Division, USACERL. Brad J. Lewis, corrosion engineer for Santa Fe Pacific Pipelines, Eastern District, assisted USACERL in field evaluation of underground pipelines. Also invaluable to the successful completion of this work were Leon Howard, Directorate of Public Works (DPW), Fort Hood, TX, and Carrol Shepherd, DPW, Fort Lee, VA. The USACERL principal investigator was Vincent F. Hock. Dr. Paul Howdysshell is Chief, CECER-FM, and Dr. David M. Joncich is Acting Chief, CECER-FL. The USACERL technical editor was William J. Wolfe, Information Management Office.

LTC David J. Rehbein is Commander and Acting Director of USACERL, and Dr. Michael J. O'Connor is Technical Director.

Accession For	
NTIS GRAM	<input checked="" type="checkbox"/>
DTIC TAB	<input type="checkbox"/>
Unannounced	<input type="checkbox"/>
Justification	
By _____	
Distribution/	
Availability Codes	
Dist	Avail and/or Special
A-1	

Contents

SF 298	1
Foreword	2
List of Figures and Tables	5
1 Introduction	9
Background	9
Objective	10
Approach	10
Mode of Technology Transfer	11
2 Cathodic Protection: An Overview	12
Corrosion of Steel Structures	12
Cathodic Protection	12
3 Impressed Current Cathodic Protection Systems	14
Anodes	14
Power Sources	15
Ancillary Equipment	16
4 CP System Effectiveness	18
Criteria for Protection	18
Measurement Techniques	19
Measurement Devices	21
5 Laboratory Tests	27
Laboratory CP Systems	27
Test Procedures	28
Discussion of Results	28
6 Field Tests	43
Underground Fuel Storage Tank–Fort Lee, VA	43
Elevated Water Storage Tanks–Fort Hood, TX	45
Underground Pipeline Systems–Tucson, AZ	47

7 Conclusions 58
 Underground Fuel Storage Tank 58
 Elevated Steel Water Storage Tanks 59
 Underground Gas Distribution Systems 59

8 Recommendations 60

References 61

Appendix A: Laboratory Data 62

Appendix B: Fort Hood Field Data 65

Appendix C: Criteria for a Low-Maintenance CP System 69

Distribution

List of Figures and Tables

Figures

1	A typical corrosion cell	13
2	A typical cathodic protection system	13
3	Potential and potential shift criteria for cathodic protection of steel	23
4	Typical CP measurement circuit	24
5	Typical cathodic protection waveform	24
6	Pulse generator and waveform analyzer model WFA-1	25
7	Waveform analyzer/pulse generator measurement system	25
8	Cathodic protection analyzer Model 730 and SP1 Probe	26
9	Measurement circuit for cathodic protection analyzer Model 730	26
10	Laboratory CP system configuration	31
11	Experimental CP systems	32
12	Steel plates used in laboratory experiment	32
13	Ceramic-coated rod anode used in laboratory tests	33
14	GoodAll rectifier (Tank 1)	34
15	VADC rectifier (Tank 3)	35
16	Hewlett Packard DC power source (Tank 4)	36
17	Photovoltaic panel (Tank 2)	36
18	Full-wave rectified waveform from Tank 1	37

19	On-potentials vs. time for Tank 1	38
20	Off-potentials vs. time for Tank 1	38
21	CP waveform from Tank 3	39
22	On-potential vs. time for photovoltaic panel for 48-hour period	42
23	On-potential vs. time for photovoltaic panel for 20-day period	42
24	Location of soil resistivity test points using Wenner 4-pin method	48
25	Location of current requirement test points	50
26	A typical ceramic-coated canister anode	51
27	Layout of installed cathodic protection system	52
28	Amplified oscilloscope trace CP waveform for UST at Fort Lee, VA	54
29	Typical elevated water tank showing ceramic-coated rod anode arrangement	55

Tables

1	Native potentials for experimental steel plates	33
2	Power sources used in laboratory tests	33
3	Potential voltage measurements for Tank 1	37
4	Potential measurements by reference cell position for Tank 1	37
5	Potential measurements for Tank 3	40
6	Potential measurements by reference cell position for Tank 3	40
7	Potential measurements for Tank 4	40
8	Potential measurements by reference cell position for Tank 4	41

9	Potential measurements for Tank 2	41
10	Potential measurements by reference cell positions for Tank 2	41
11	Soil resistivity data	49
12	Structure-to-soil potential measurements at CP system energization (1989)	49
13	Current requirements test data	50
14	Structure-to-electrolyte potentials	53
15	Pipe-to-soil potential measurements, 6-in. pipeline	56
16	Pipe-to-soil potential measurements, 8-in. pipeline	56
17	Pipe-to-soil potential measurements, 12-in. pipeline	57
A1	Water sample chemistry data	62
A2	Laboratory structure-to-electrolyte potential (Tank 1)	63

1 Introduction

Background

Metallic structures buried in soil or immersed in water tend to corrode. In storage tanks and piping systems, corrosion can cause system failures, costly maintenance, and leaks of hazardous materials such as fuel and oil into the environment. The Army currently operates and maintains more than 20,000 underground steel tanks, 3000 miles of buried pipeline, and 300 elevated water storage tanks. Such a vast network of steel structures requires some form of corrosion control—corrosion alone costs the Army \$300 million annually. Moreover, U.S. Environmental Protection Agency (USEPA) rules require the Army to provide cathodic protection, leak detection, and inspection of existing underground fuel storage tanks.

Impressed current cathodic protection (CP) systems can help control corrosion-induced leaks when a steel structure is exposed to an aggressive soil or water. The development of the ceramic coated anode for impressed current CP systems has reduced the problems associated with anode installation and maintenance. However, once a CP system is installed, its effectiveness must be determined to maintain corrosion control for a given structure. The effectiveness of any impressed current CP system can be determined by taking potential measurements between the structure and a reference electrode. Such potential measurements have traditionally been recorded with average reading digital voltmeters while the protective current is flowing. These on-potential measurements contain the error produced by the voltage drop in the electrolyte (soil or water) and the voltage drop in the structure being protected. This error is often referred to as IR drop. An off-potential measurement is a reading taken instantaneously after the protective current reaches zero. Off-potential measurements eliminate the IR drop error, allowing the true polarized potential of a cathodically protected structure to be determined in the field. Several commercially available systems are designed to make this crucial measurement. Laboratory and field tests of these systems are needed to determine if they can be used to help evaluate Army CP systems.

Objective

The objective of this study was to evaluate the laboratory and field performance of commercially available off-potential measurement systems for impressed current cathodic protection. The ability of off-potential instrumentation to measure the true polarized potential of a structure was to be determined to ensure compliance with NACE RP0169 criteria for cathodic protection.

Approach

1. Four separate CP systems were set up in four laboratory experiments, each system powered by a different type of power source.
2. Performance of each experimental system was monitored by taking measurements between the structure and the Cu/CuSO₄ reference cells.
3. Commercially available systems were used to measure off- and on-potentials, and off-potential measurements were compared to actual readings taken with an oscilloscope.
4. Three sites were selected for field tests of off-potential measurement devices on one underground storage tank (at Fort Lee, VA), one elevated water storage tank (at Fort Hood, TX), and an underground pipeline system (Tucson, AZ).
5. System performance was monitored to determine effectiveness relative to revised National Association of Corrosion Engineers (NACE) Recommended Practice (RP) 0169 (1992 Revision), "Control of External Corrosion on Underground or Submerged Metallic Piping Systems," and RP0285, "Control of External Corrosion on Metallic Buried, Partially Buried, or Submerged Liquid Storage Systems." The accuracy of off-potential measurement devices was also determined in relationship to the revised criteria.
6. Results of the measurements taken with the various systems were compared with readings taken with an oscilloscope and analyzed, and appropriate recommendations were made for CP system monitoring.

Mode of Technology Transfer

Demonstrations of this technology at Army installations are planned for Fiscal Year 1993 (FY93) as part of the Facilities Engineering Applications Program (FEAP). Specifications for this instrumentation will be published as a Public Works Technical Bulletin (PWTB), to be published by the U.S. Army Center for Public Works. It is recommended that the results of this study be incorporated into Corps of Engineers Guide Specifications (CEGS) 16640, 16641, 16642, and Engineer Technical Letter (ETL) 1110-9-10 (FR), *Impressed Current Cathodic Protection Systems Using Ceramic Anodes* (Headquarters, U.S. Army Corps of Engineers [HQUSACE], 1991).

2 Cathodic Protection: An Overview

Corrosion of Steel Structures

Corrosion occurs by an electrochemical process. A corrosion cell consists of four parts: an anode, cathode, electrolyte (corrosive soil or water), and metallic connection. Current leaves the structure at the anode site, passes through the electrolyte, re-enters the structure at the cathode site, and returns to the anode via the structure metal (Figure 1).*

Corrosion, or the dissolution of metal, occurs at the anode site. Electrons that are lost at the anode flow through the metallic circuit to the cathode and permit a cathodic reaction to occur. This results in a gain of electrons at the cathode, which produces an overall oxidation-reduction reaction. Insoluble corrosion products are the net result, which form at the cathode by a nonelectrochemical reaction (Myers 1974).

Cathodic Protection

To mitigate corrosion, the anodic current leaving the structure must be appreciably reduced. Cathodic protection minimizes anodic dissolution by reducing the potential difference between the cathodic and anodic sites. This is an electrical method of preventing corrosion on structures that are exposed to electrolytes such as soils and waters. A CP system forces all parts of the structure to become a cathode by applying a current from an outside source. When enough current is applied, the anode and cathode sites do not exist on the structure, so that corrosion does not occur. Figure 2 shows a typical CP system.

The protective current in a CP system can be produced in two ways. When two electrochemically dissimilar metals/alloys are connected and exposed to an electrolyte, a current is produced. This process is used in sacrificial anode type systems. Impressed current systems use an external power source to apply protective current through an auxiliary anode (Myers 1974).

* Figures and tables are included at the end of their associated chapter.

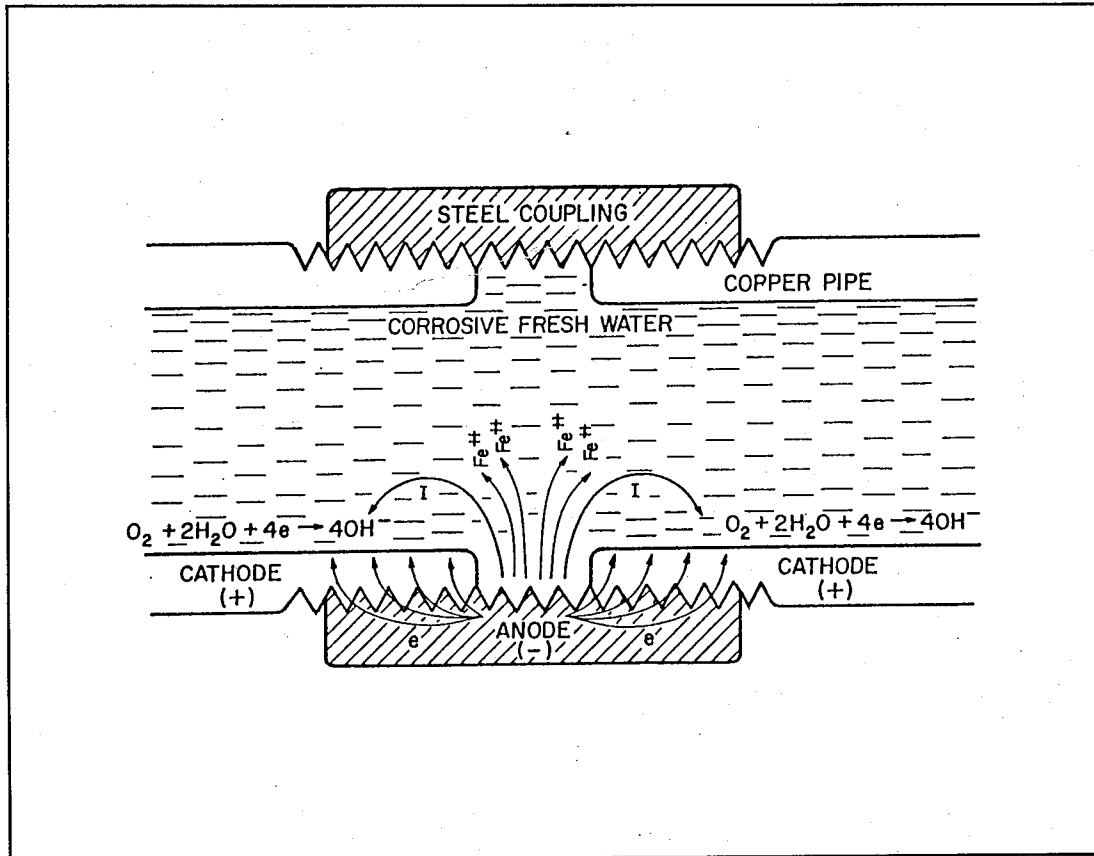

Figure 1. A typical corrosion cell.

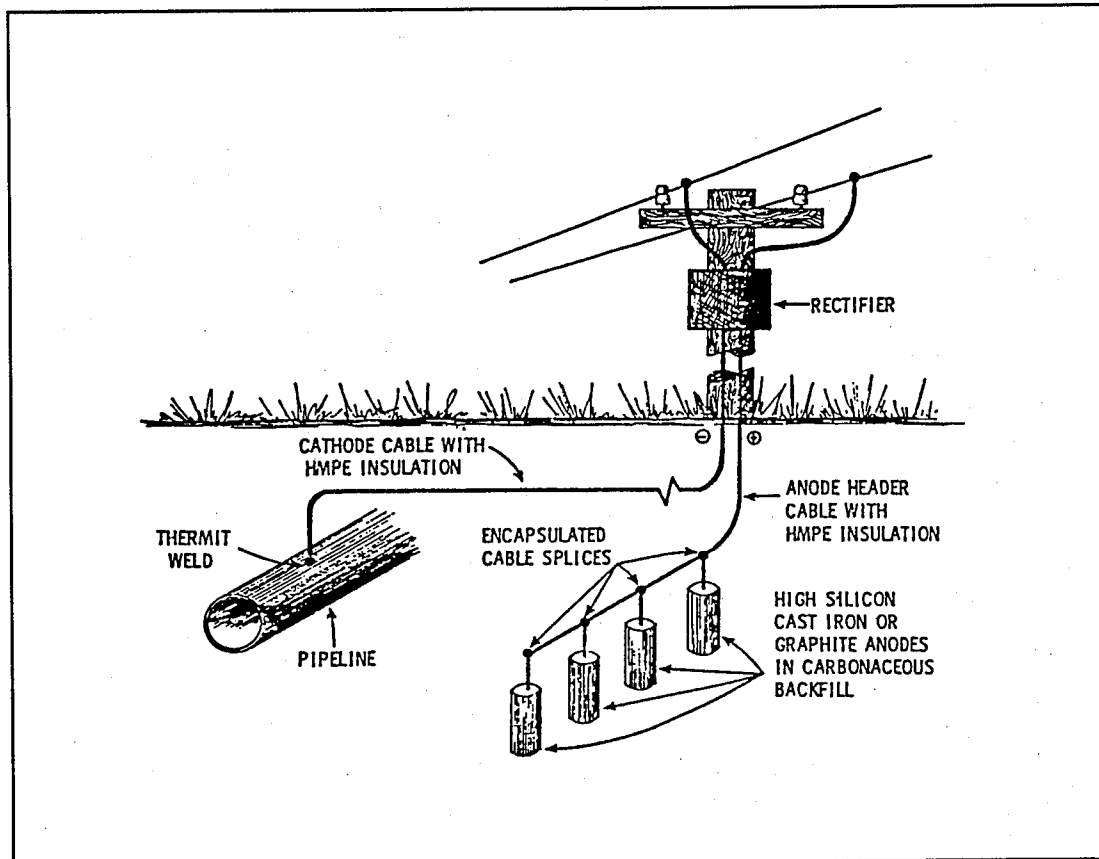

Figure 2. A typical cathodic protection system.

3 Impressed Current Cathodic Protection Systems

The basic components of an impressed current type CP system are a direct current (DC) power source (usually a rectifier), a group of auxiliary anodes, the structure to be protected, and leadwires connecting the anodes and structure to the power source.

Anodes

The cathodic protection current is applied through an anode, which is consumed over time. Silicon-iron and graphite, the most commonly used impressed current anode materials, have two major disadvantages: (1) They have a high consumption rate (1 lb per ampere-year),* and (2) they tend to be brittle and break easily when mishandled. The high consumption rate of the anode necessitates a large size, making it more vulnerable to damage and less easily placed in small spaces. Standard impressed current anode systems are also prone to problems with field installation, particularly in the anode-to-lead wire connection, which can result in electrical shorts in the system. These problems reduce the reliability of impressed current cathodic protection systems to only 50 percent in some cases.

Since the early 1980s, a new type of composite anode material has been used for various electrochemical processes, particularly in the electrolytic production of chlorine and cathodic protection systems including off-shore, water tank, and grounded applications. The development of various ceramic-coated anode shapes has eliminated many of the problems related to the design and installation of a CP system. The mixed metal oxide (MMO) ceramic-coated anodes consist of a 50/50 atomic percent mixture of iridium and titanium oxides, with a small amount of ruthenium and tantalum oxides. The MMO films are fabricated by spraying aqueous salts of the metals onto the titanium substrate and then heating the titanium to a temperature of several hundred degrees Celsius.

* 1 lb = 0.453 kg.

The advantage of fabricating anodes from these materials is a very low dissolution (wear) rate. Typical wear rate values are 6 mg/A-yr in chloride deficient (fresh) waters, at an anode current density of 13.9 A/sq ft (150 A/m²), and 0.5 to 1.0 mg/A-yr in seawater or brine at an anode current density of 55.7 A/sq ft (600 A/m²).* Information regarding specifications of these types of anodes has been previously published. (ETL 1110-9-10 January 1991; Kumar, Hock, and McLeod 1992).

Power Sources

To provide continuous protective current for a CP system, a DC power source is required. The DC source used with impressed current CP systems can be a transformer-rectifier, solar photovoltaic cell, thermoelectric generator, turbine generator, engine generator, or a wind-powered generator. The transformer-rectifier is the most common (and practical) power source used in the field (estimated 95 percent). A rectifier takes an ordinary AC signal from a power line, and converts it into a DC signal through a transformer and rectifying elements. All components are enclosed in a suitable cabinet or housing. There are three basic types of rectifiers used in cathodic protection: (1) the constant voltage rectifier, (2) the constant current rectifier, and (3) the automatic potential controlled rectifier.

The constant voltage rectifier is the cheapest and the most simple to operate, but is not the most practical in keeping a structure protected in some CP system environments because it provides the anode and the cathode (or structure) with a constant voltage rather than a constant current. A supplied constant voltage does not ensure proper protection because cathodic protection requires a specific amount of current—not simply voltage—to be supplied. A constant voltage supply can allow the resistivity between the anode and the cathode to change. If the anode and cathode are in soil, the resistivity will change due to the moisture content in the soil. If the anode and the cathode are in water, the resistivity will change due to the varying water levels and the different ions in the water each day. The constant voltage rectifier may not be the most practical to use in a low-maintenance CP system.

The constant current rectifier is practical for more applications than the constant voltage rectifier because the operator can ensure that a structure will be protected by simply setting the output of the constant current rectifier to the specific CP current previously measured in the current requirements testing. In energizing most CP systems, the DC current output is adjusted to maintain the level of protection specified by the National Association of Corrosion Engineers (NACE). (Chapter 4 gives

* 1 sq ft = 0.093 m².

protection criteria.) The constant current rectifier is best suited for CP applications where the range in expected soil resistivities is relatively small, and where there is no dramatic change in the structure area to be protected or the anode output area due to rising and falling water levels.

The automatic potential-controlled rectifier is the most advanced, but also the most expensive of the three basic types of rectifiers. It is only practical for CP systems where there is a fluctuation in the properties of the electrolyte. If a CP system will be subject to a wide range of electrolyte resistivities, or if the surface area of the structure to be protected and of the anode output changes (for example, rising or falling water levels in a tank or on a lock gate), an automatic potential-controlled rectifier is suitable. This rectifier operates by using a specified threshold setting as a control to maintain a structure-to-electrolyte potential that ensures protection. The rectifier continuously measures the corrosion potential and varies its output to obtain the set potential. This rectifier is recommended for use in all submerged and/or all moving water applications.

A new type of rectifier is being developed by industry that will contain dependable switch-mode technology. It will switch between a constant-current and a varying output that would be determined by measuring a structure-to-electrolyte potential. This rectifier will contain a 16-bit coprocessor that allows a user to access a menu to set current and potential levels through a keyboard that can be plugged into the rectifier. An option available on this rectifier will be a modem that will permit a facility inspector to check the operation of the rectifiers from the office by calling each rectifier through a computer. This would eliminate the monthly requirement for facility personnel to inspect each rectifier in the field to guarantee its operation.

Ancillary Equipment

The ancillary equipment in a CP system includes the anode-to-lead wire connections and moisture seals, backfill material, vent pipe, shunts and junction boxes. For a CP system to operate efficiently and effectively, the ancillary equipment must not fail.

The anode lead wire connections and moisture seals are of utmost importance. The lead wire connections must be well insulated from the environment and must carry the protection current without a loss of power due to high resistance. The wire connection to the anode, and any other wire connections, must prohibit the influx of water. A permeable moisture seal at a wire connection will provide an environment for rapid corrosion to occur on the wire. If the wire corrodes, it produces a higher resistance, and a power loss in the connection means less protective current reaching the cathode

via the anode. Eventually the wire will corrode to the breaking point, leaving no protective current; the structure will corrode rapidly, and repair and replacement costs will skyrocket. The ceramic-coated anode technology eliminates this problem by using anode rod segments that can be threaded together to provide a custom length anode system.

Proper backfill material will ensure that the anode is exposed to a low resistance environment. The gases produced at the anode (for example; oxygen, carbon dioxide, chlorine, or others) build up pressure and drive water away from the anode. This increases electrolyte resistance, which should be minimized. Even though the backfill material provides a low resistance environment for the anode, it cannot provide an easy escape for gases in all CP applications. In this case, a vent pipe must be installed into the anode bed. Vent pipes are typically installed in deep ground beds where the path for the gases to reach ground level is substantial. Vent pipes provide an easy path for gases to reach ground level and not increase the resistance of the electrolyte surrounding the anode.

Shunts and junction boxes are used to help make maintenance measurements to ensure that the CP system is operating correctly. The junction boxes should be easily accessible by an inspector, but must keep moisture out. The hazards of moisture have been explained above. The shunts used in the junction boxes shall have a simple ratio such as 1 mV/1 A or 10 mv/1 A. This makes it easier for an inspector to read a voltage and calculate the corresponding current via Ohm's Law, $V=IR$.

Other ancillary equipment may include anode centering devices, anode support pipes, or anode weights. These devices are used mostly in water CP applications and they help ensure that the anode is placed in accordance with the engineering drawings that define the system. Although there may be moving water around the anode, these devices will keep them in a stationary, correct position.

4 CP System Effectiveness

Criteria for Protection

To monitor CP system performance, one must be able to pinpoint malfunctions in the system. It is therefore essential to understand the criteria used to determine whether the structure is being cathodically protected. Cathodic protection engineers have not accepted a single criterion to practically measure cathodic protection in the field under all circumstances. Therefore, to understand the criteria of CP, it is critical to understand the changes that occur in the electrical potential of a structure when the protective current is applied. Husock (1979) explains:

It should be noted that cathodic protection when properly applied produces a change in the potential of a structure with respect to a reference electrode placed in the soil in proximity to that structure. The cathodic protection current makes the potential thus measured more negative than the potential was before the current was applied, and the amount of change produced is a measure of the effectiveness of the cathodic protection at that location.

Figure 3 shows the changes in the structure's electrical potential (with respect to a copper-copper sulfate reference electrode) that occur when the cathodic protection current is applied. Before current is applied, the structure is at its original or "native" potential. When the current is applied, there is a change in potential in the negative direction at the instant the current is turned on. As the current is continuously applied over an extended period of time, the potential tends to increase negatively because of polarization. According to Husock (1979), "polarization of a structure is a phenomenon which occurs over a long time period and a structure may not be entirely polarized even after the cathodic protection system has been in operation for many months." If the current is interrupted after the structure has polarized, the potential becomes less negative at the instant of turn-off. The potential then begins to decay, or depolarize, back to the original or native potential.

For cathodic protection criteria, corrosion engineers usually rely on two NACE Recommended Practices (RPs): RP0169 (1992 Revision), "Control of External Corrosion on Underground or Submerged Metallic Piping Systems," and RP0285, "Control of External Corrosion on Metallic Buried, Partially Buried, or Submerged Liquid Storage Systems." Although there are some differences in the wording of the

two RPs due to the different structures that are described, the content is essentially the same.

The current NACE criteria for underground or submerged metallic piping (RP0169-92) states that the following conditions may be used:

6.2.2 Steel and Cast Iron Piping

6.2.2.1 Corrosion control can be achieved at various levels of cathodic polarization depending on the environmental conditions. However, in the absence of specific data that demonstrate that adequate cathodic protection has been achieved, one or more of the following shall apply:

6.2.2.1.1 A negative (cathodic) potential of at least 850 mV with the cathodic protection applied. This potential is measured with respect to a saturated copper/copper sulfate reference electrode contacting the electrolyte. Voltage drops other than those across the structure-to-electrolyte boundary must be considered for valid interpretation of this voltage measurement.

NOTE: Consideration is understood to mean the application of sound engineering practice in determining the significance of voltage drops by methods such as:

6.2.2.1.1.1 Measuring or calculating the voltage drop(s);

6.2.2.1.1.2 Reviewing the historical performance of the cathodic protection system;

6.2.2.1.1.3 Evaluating the physical and electrical characteristics of the pipe and its environment; and

6.2.2.1.1.4 Determining whether or not there is physical evidence of corrosion.

6.2.2.1.2 A negative polarized potential of at least 850 mV relative to a saturated copper/copper sulfate reference electrode.

6.2.2.1.3 A minimum of 100 mV cathodic polarization between the structure surface and a stable reference electrode contacting the electrolyte. The formation or decay of polarization can be measured to satisfy this criterion.

Measurement Techniques

To monitor system performance, potential measurements are taken between the structure and a reference cell, usually Cu/CuSO₄. Figure 4 shows a typical measure-

ment circuit for a CP system. To meet the NACE criteria, the true polarized potential of the structure must be determined. Therefore, when measurements are interpreted, the IR drop error must be accounted for to obtain an IR free potential. Figure 3 shows the region—of the potential-versus-time curve—that is considered to be the IR drop.

Any attempt to measure the structure-to-soil potential must take these IR drops into account: the soil (electrolyte) IR drop and the structure (metal) IR drop. It is possible to significantly reduce the soil IR drop by placing the reference electrode immediately adjacent to the structure. This technique will only provide a localized potential reading for the structure because the reference cell is only reading a limited area. An overall structure potential can be determined by taking measurements at several locations on the structure using this method. This method is also limited to structures for which close placement of the reference cell is possible.

Another method of measuring the polarized potential of a structure is to measure the potential instantaneously after the cathodic protection current is interrupted. This is known as the off-potential, or the “instant-off” potential (IOP). IR drop error is eliminated since there is no current flowing when the measurement is taken (i.e., $I=0$). IOP measurements in the field allow the polarized potential of the protected structure to be determined, and can provide information regarding both rectifier performance and corrosion prevention for the CP system.

Two methods of IOP measurement are possible. One method involves a real time analysis of the waveform produced by the CP rectifier. A typical CP rectifier will produce a full-wave rectified waveform (Figure 5). On the flat portion of the waveform, or the minimum, the CP current instantaneously reaches zero. The potential measured at this point may be taken as the IOP. This method of measurement is dependent on the presence of a clearly defined CP waveform, which will reveal a well defined flat portion.

Besides direct analysis of the CP waveform, an IOP may be determined by measuring the potential of the structure after interruption of protective current. Current interruption is usually accomplished by installing an interruption device in series with the power source. When current is interrupted, the potential of the structure will begin to decay, as shown in Figure 3, and will eventually reach the native potential. When using this technique, a measurement of the IOP must be taken before the potential has substantially decayed. The interruption device is often set to an exact timing cycle for this purpose.

On some structures, inductive and capacitive spiking may occur upon interruption of protective current. This is sometimes seen on cathodically protected long distance

pipelines. Spiking may be present on the CP waveform, or may be the result of current interruption. The measurement of the IOP must account for such spikes.

Measurement Devices

Digital Multimeter

A common device used to measure potentials in the field is a Digital Multimeter (DMM). This device, when operated in DC mode, measures an average value of DC current (or voltage) for a given waveform, which is considered to be the on-potential. The IR drop error is present in this measurement, and can be corrected by moving the reference cell very close to the structure or by turning off the power source and taking a IOP reading after the meter has updated. A current interrupter may also be placed in the CP circuit to interrupt the current on an exact timing cycle.

Oscilloscope

An oscilloscope can provide a complete description, or picture, of a given waveform (Figure 5). This will precisely determine the real-time cathodic protection potential seen by the structure. Oscilloscopes are mainly used in laboratory settings, but digital handheld oscilloscopes are available for use in the field. With storage capabilities, the potential readings may be recorded by a digital oscilloscope.

M.C. Miller Waveform Analyzer (WFA) Model WFA-1

The Waveform Analyzer Model WFA-1 is a portable, handheld, auto-ranging voltmeter that measures real-time characteristics of the cathodic protection waveform (Figure 6). This device uses a complex algorithm to measure the on and IOP potentials. This device has three modes of operation: (1) the WFA mode; (2) the DC mode, and (3) the AC mode. The WFA mode consists of both on- and off-potential readings. The on-potential is an average value, while the off represents the IOP, or the minimum portion of the waveform shown in Figure 5. In the DC mode, the average potential of the CP waveform can also be read. The AC mode is similar to an auto-ranging AC voltmeter (M.C. Miller Co.).

To accurately calculate the off-potential, a pulse generator must be installed for each power source providing cathodic protection current. The pulse generator interrupts the rectifier current on a precise timing cycle, thus generating a "zero current pulse." A pulse generator can be installed permanently in a CP system, and requires no

synchronization. Figure 7 shows the CP system and the measurement circuit using the WFA-1/Pulse Generator system.

The algorithm used by the WFA-1 to calculate the off-potential involves sampling thousands of readings per second and digitally filtering out any induced AC noise to obtain an on-potential. Then, the total IR drop contribution is calculated and subtracted from the on-potential to give the desired off-potential.

Xetron Cathodic Protection Analyzer (CPA) Model 730

The CPA Model 730 is a handheld datalogging instrument used with a reference electrode to measure real-time characteristics of the cathodic protection voltage waveform (Figure 8) (*Pipeline and Gas Journal* 1990). A real-time analysis is performed without the need of a current interruption device. Figure 9 shows the measurement circuit for the CPA 730. The CPA has six modes of operation, including maximum, average, and minimum potential readings. The average reading is equal to the reading from an accurate averaging digital voltmeter, or the on-potential. The minimum reading, the most positive voltage on the cathodic protection waveform, is taken as the polarized potential, or IOP (CPA 730 Manual).

Three additional modes of the CPA 730 include a threshold setting, threshold percent time, and threshold average. The threshold voltage can be entered by the user on the numerical keypad. The threshold percent time is the percentage of time that the cathodic waveform is more positive than the selected threshold voltage. The threshold average reading is the average of the cathodic protection waveform voltage that is more positive than the selected threshold voltage (Xetron Corp. 1990).

The CPA may be used with a standard Cu/CuSO₄ reference electrode, or with the optional SP1 probe (a shielded reference electrode that is the same size as a conventional half cell). This device is designed to electronically bring the structure to the surface, which eliminates the resistance of the soil (or water) in the IR drop equation. Within the probe is a reference electrode, a coupon, and an anode. The probe is filled with a liquid electrolyte. An internal calibration is used to give the same type of IR drop free measurement as a reading taken in close proximity of the protected structure. The probe has been designed to operate on any type of CP system, and to work in congested areas with a myriad of adjacent structures (Watts 1989).

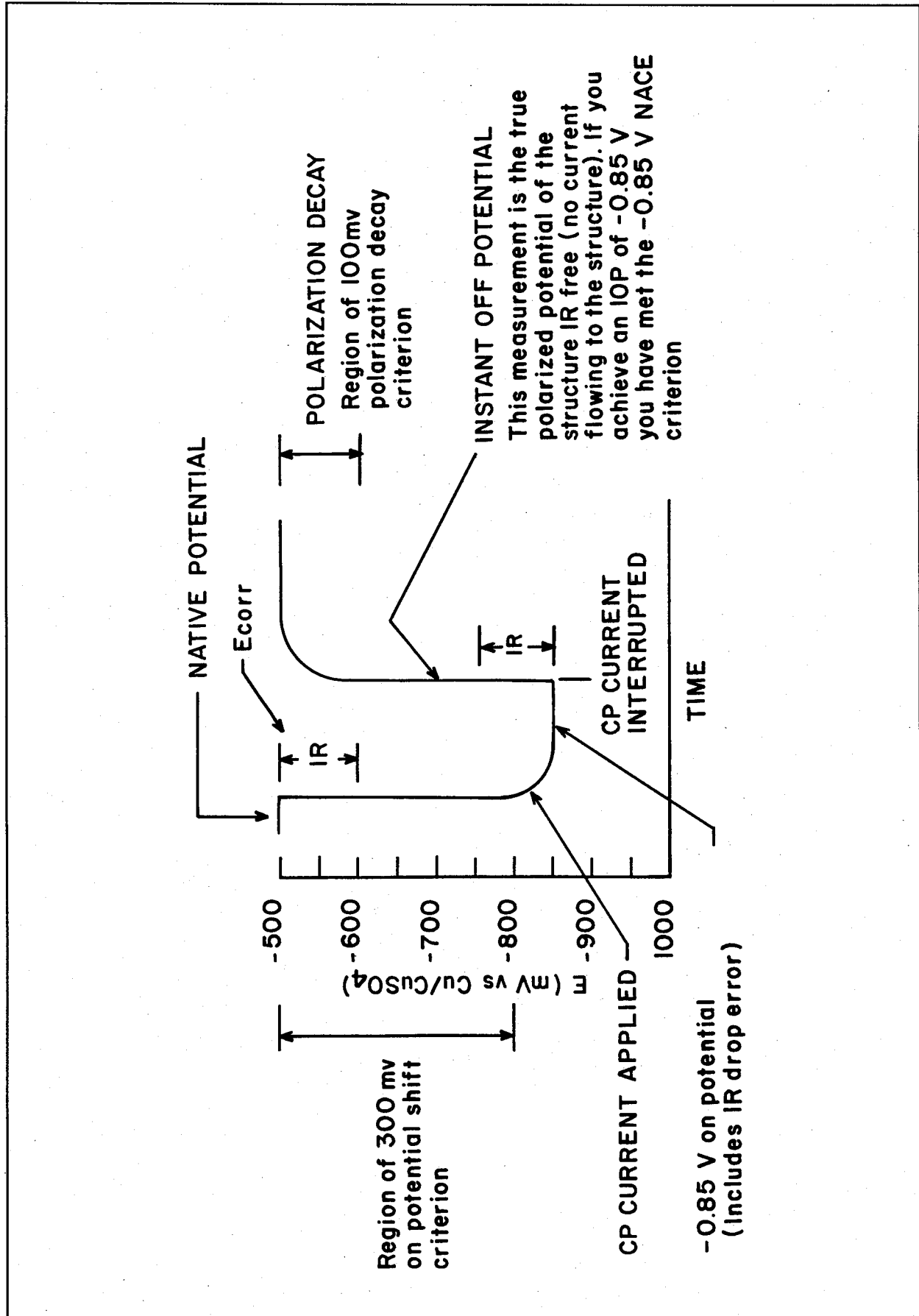

Figure 3. Potential and potential shift criteria for cathodic protection of steel.

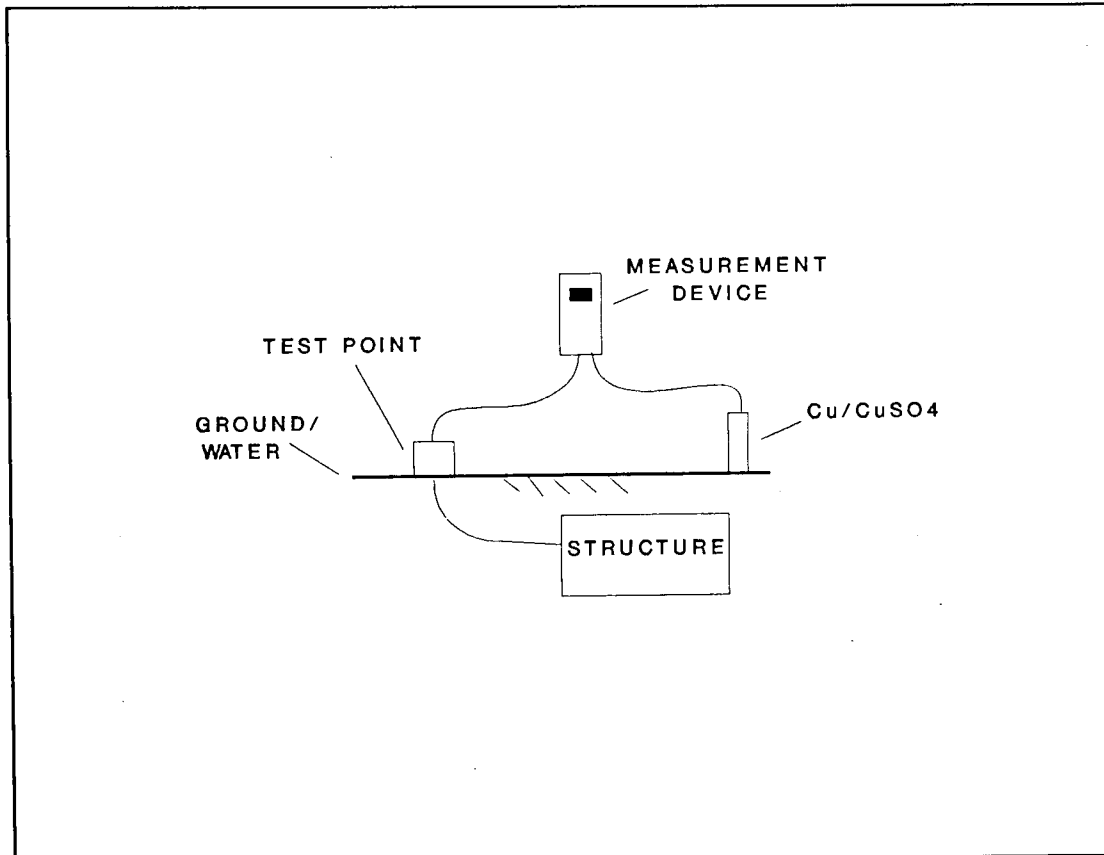

Figure 4. Typical CP measurement circuit.

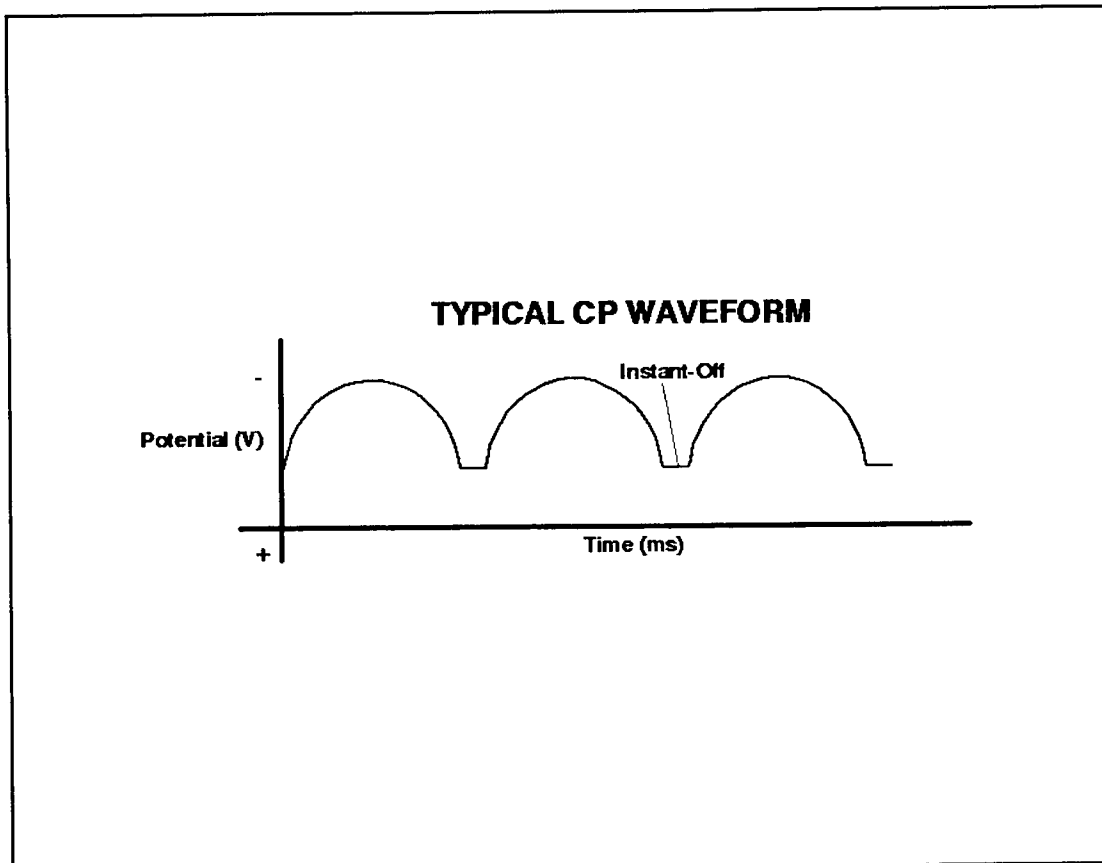

Figure 5. Typical cathodic protection waveform.

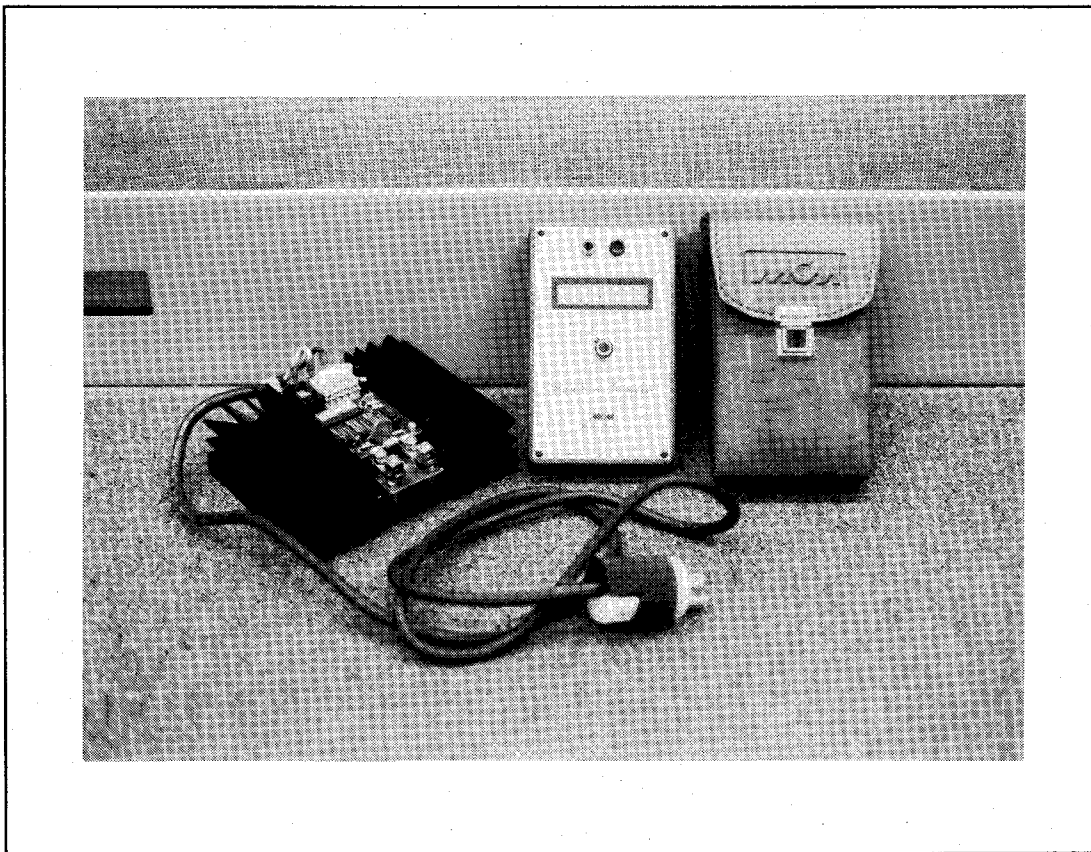

Figure 6. Pulse generator and waveform analyzer model WFA-1.

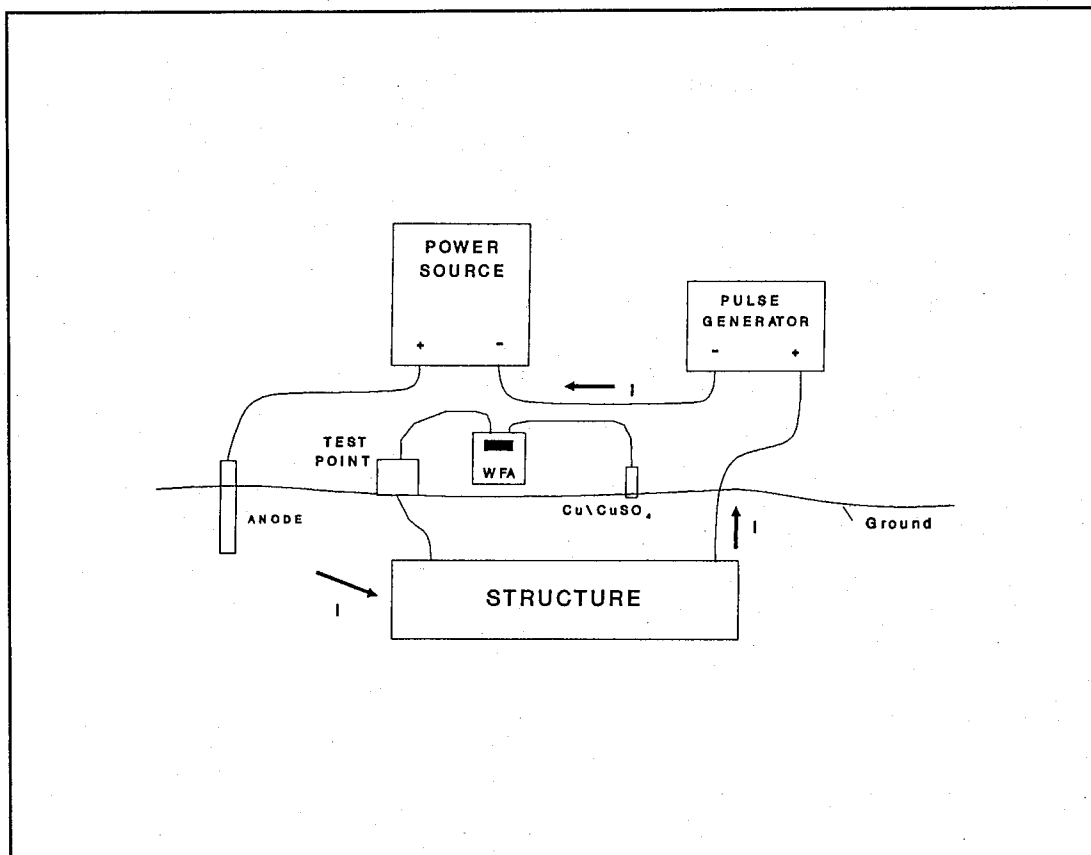

Figure 7. Waveform analyzer/pulse generator measurement system.

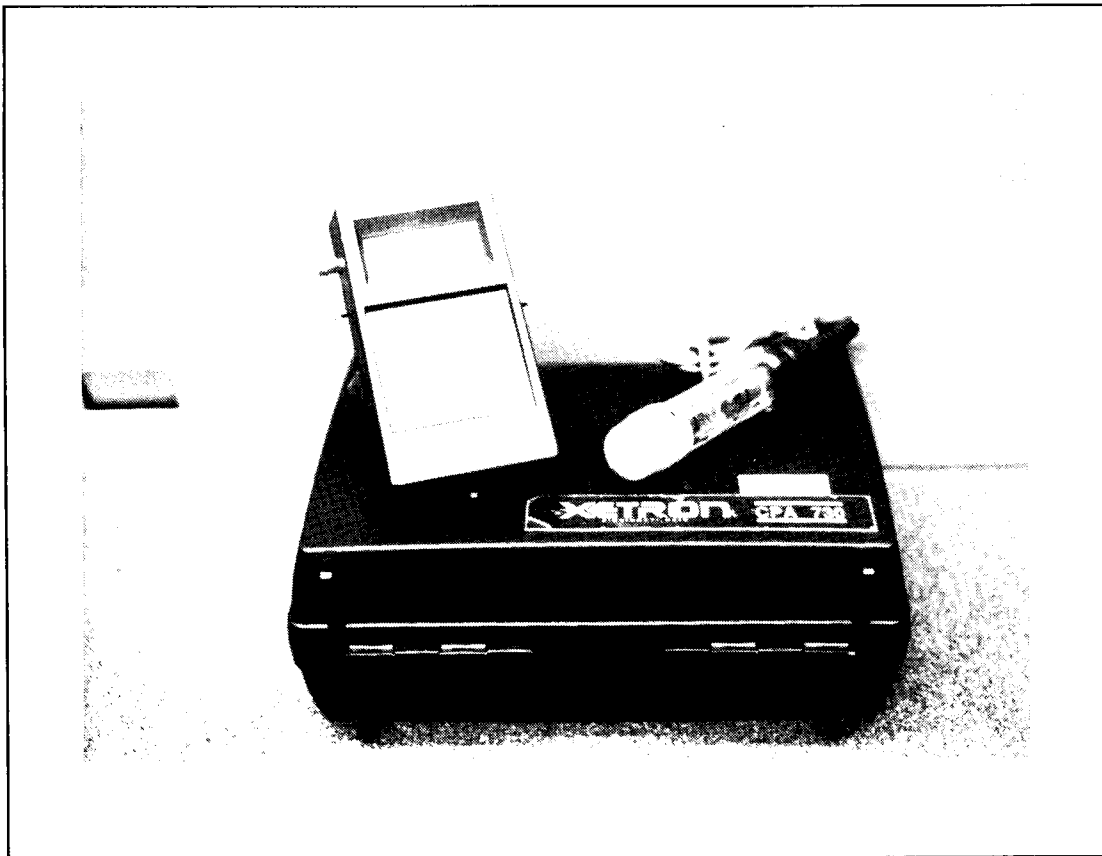

Figure 8. Cathodic protection analyzer Model 730 and SP1 Probe.

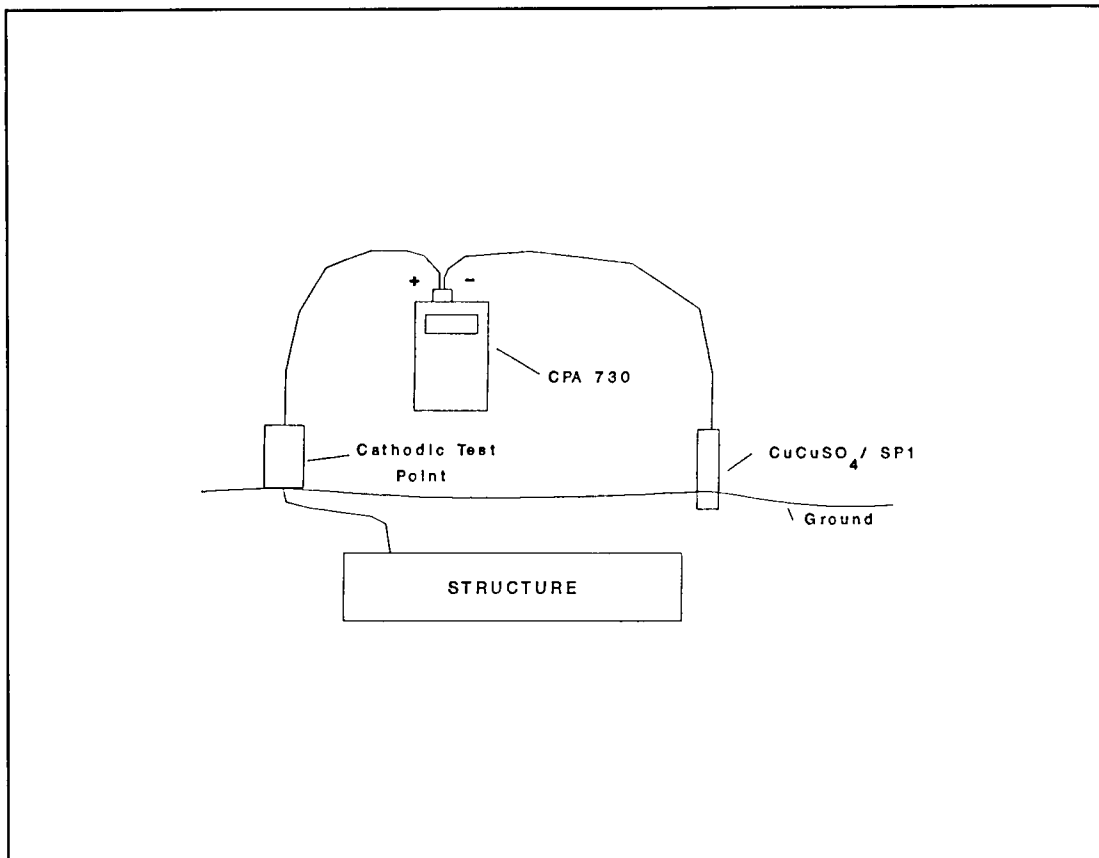

Figure 9. Measurement circuit for cathodic protection analyzer Model 730.

5 Laboratory Tests

The laboratory investigation evaluated the system performance of four CP systems in a controlled experimental environment. Various power sources were used and potential measurement instrumentation was evaluated. The objective of the laboratory tests was to determine the ability of the off-potential instrumentation to measure the true polarized potential of the structures being protected for each system.

Laboratory CP Systems

Four separate CP systems were set up and configured (Figure 10). Each system consisted of a nonmetallic freshwater tank in which steel plates (structures) and ceramic-coated rod type anodes were immersed. Standard, permanent Cu/CuSO₄ reference cells were used to take potential measurements of the immersed structures. Figure 11 shows the experimental setup.

The dimensions of the A36 steel plates used were 12 X 12 X 1/16 in. (Figure 12) and the plate surfaces were sandblasted to near white before being immersed in the water tanks. Native potentials were measured after immersing the plates in fresh water and allowing the potentials to come to rest after several minutes. Table 1 lists the results. Typical corrosion rates for such steel are 2-4 mils per year.

Ceramic-coated rod type anodes were used on each system. Figure 13 shows an anode in one of the experimental systems.

Different power sources were used on each of the four CP systems set up in the laboratory (Table 2). Figures 14 to 17 show each examined power source. Two types of rectifiers were evaluated to determine their capabilities of maintaining a constant polarized potential of the steel structures. A photovoltaic panel was also evaluated to determine its ability to provide continuous corrosion protection during the day and to observe the effects of polarization decay at night.

Test Procedures

Each experimental CP system's performance was monitored by taking potential measurements between the structure and Cu/CuSO₄ reference cells, using the NACE criteria of -0.85V polarized potential. The CPA 730 and WFA-1/Pulse Generator were evaluated to determine the ability of each to measure off-potentials (IOPs) for the different CP waveforms generated by each source. A Fluke 75 digital multimeter was also used to measure on-potentials. The off-potential measurements were compared to actual readings determined with an oscilloscope.

Test procedures were:

1. Water samples (electrolyte) were taken for each tank (Appendix A).
2. Native potentials were measured when the plates were immersed in each tank (Table 1).
3. The power sources were adjusted to produce a polarized potential of about -0.85V with respect to a Cu/CuSO₄ reference cell.
4. Each system was allowed to polarize.
5. Further adjustments were made as necessary, and then the settings were not altered.
6. On- and off-potential measurements were taken for each system using various instrumentation.
7. The standard reference cell was moved and the measurements were repeated.
8. The measurements were repeated with a permacell for comparison.
9. A data logger was interfaced with a PC to log on-potentials continuously.
10. Water samples were taken at the end of the experiment (Appendix A).

Discussion of Results

For the GoodAll full-wave rectified waveform of Tank 1, measurements were taken with the CPA 730 (with and without the SP1 probe), WFA-1/Pulse Generator, Fluke

75 multimeter, and an oscilloscope. The VADC filtered rectifier, the DC source, and the photovoltaic panel each produce a pure DC signal. Therefore (neglecting measurement noise) the maximum, average, and minimum values of the waveform are all equal. For these power sources, the CPA 730 with SP1 probe, WFA-1/Pulse Generator, and Fluke 75 were used. Readings were taken over a 6-week period, and a total of 54 measurements were recorded for each tank. Appendix A lists the raw data. The remainder of this chapter elaborates on selected data points.

GoodAll Full-Wave Rectifier—Tank 1

Figure 18 shows a full-wave rectified waveform reproduced from an actual oscilloscope trace for Tank 1. The waveform clearly shows the maximum, average, and minimum values. The flat portion, or minimum, corresponds to the point where the current instantaneously reaches zero. This point is considered the IOP for measurement purposes. Table 3 shows some potential measurements with the reference cell 4.0 in. from the structure.

The results in Table 3 show a very close agreement for each device. The CPA minimum, SP1, and WFA-1 off readings are nearly identical to the minimum reading given by the oscilloscope. This indicates each device is accurately measuring the IOP for this particular system.

The effect of the reference cell position was also investigated. Measurements were taken at distances of 0.5, 9.0, and 18.0 in. from the structure. Table 4 shows sample results. The results show an increase (negatively) in on-potentials as the distance from the structure is increased. This increase is due to the IR drop associated with the water (as discussed in Chapter 4). The CPA minimum and WFA-1 off-potential readings show consistency with the oscilloscope for each of the reference cell locations. Small differences can be attributed to error in placing the reference cell. The CPA/SP1 probe readings show an increase in potential (negatively) with increased distance from the structure. This indicates an IR drop error in these measurements.

Figure 19 shows on-potentials, and Figure 20 shows IOP potentials for each device for tank 1. Each plot shows experimental system performance for approximately 1 month.

VADC Filtered Rectifier—Tank 3

Figure 21 shows a waveform reproduced from an actual oscilloscope trace for Tank 3, the VADC rectifier. The waveform shows a straight DC signal. Table 5 shows some sample measured potentials with the reference cell 0.5 in. from the structure. The IOP

readings of the WFA-1 and CPA/SP1 probe are in agreement, and the CPA/SP1 probe readings are slightly more negative (10-20 mV) for each reading.

The effect of the reference cell position was also investigated. Measurements were taken at 0.5, 9.0, and 18.0 in. from the structure. Table 6 shows the results. All of the off-potential readings of the WFA-1 are in close agreement. The CPA/SP1 probe readings show increases (negatively) in potential with increasing distance from the structure, indicating an IR drop error.

Hewlett Packard DC Power Source—Tank 4

For Tank 4, the DC power source, is a CP waveform similar to that of the VADC rectifier, as shown in Figure 21. Table 7 shows some sample measured potentials with the reference cell 0.5 in. from the structure. The IOP readings of the WFA-1 and CPA/SP1 probe are in close agreement. The CPA/SP1 probe readings are slightly more negative (20-60 mV) for each reading.

The effect of the reference cell position was also investigated. Measurements were taken at 0.5, 9.0, and 18.0 in. from the structure. Table 8 shows the results. The WFA-1 off readings are all in close agreement. Close to the structure (0.5 in.) the CPA/SP1 probe readings are slightly less negative. For distances further away from the structure, the CPA/SP1 probe readings increase negatively with distance.

Photovoltaic Panel-Tank 2

The photovoltaic source, Tank 2, was also evaluated with off-potential measurement devices. Tables 9 and 10 list readings taken during daytime hours and show the potential readings and effects of reference cell locations, respectively. Fluctuations in potential are due to varying sunlight intensity. The CPA/SP1 readings are all more negative (40 to 60 mV) than the WFA-1 off measurements.

The effect of the reference cell position was also investigated. Measurements were taken at 0.5, 9.0, and 18.0 in. from the structure. Table 10 lists the results. The WFA-1 off readings are all in close agreement. Close to the structure (0.5 in.), the CPA/SP1 probe readings are slightly less negative. For distances further away from the structure, the CPA/SP1 probe readings increase negatively with distance.

Figures 22 and 23 show on-potentials vs. time for the photovoltaic panel. These values were recorded continuously with a data logger interfaced with a personal computer. On-potentials were read and stored every 15 minutes. Figure 22 shows the on-potential readings over a 48-hour period. The data indicate that protection is only

achieved during daytime hours and polarization is reversed as sunlight disappears overnight. Figure 23 shows the on-potential readings over a 20-day period. The periodic behavior is also seen over more extended periods.

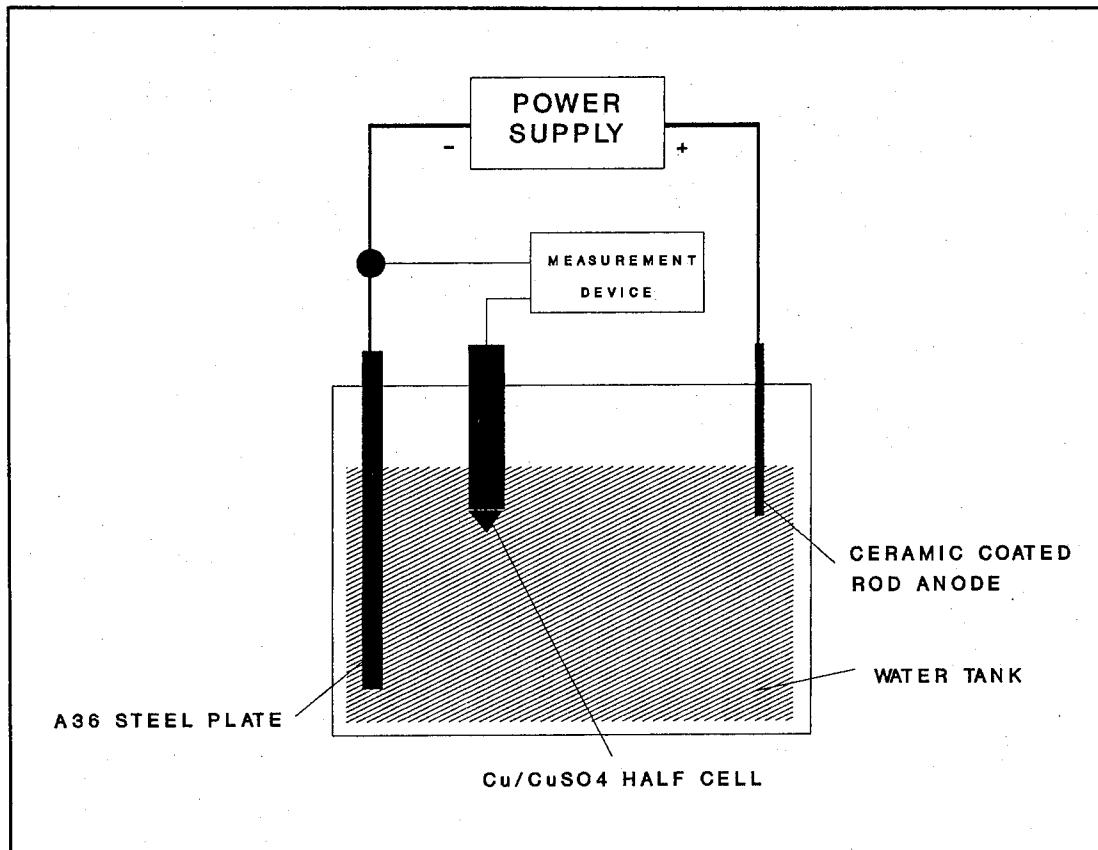

Figure 10. Laboratory CP system configuration.

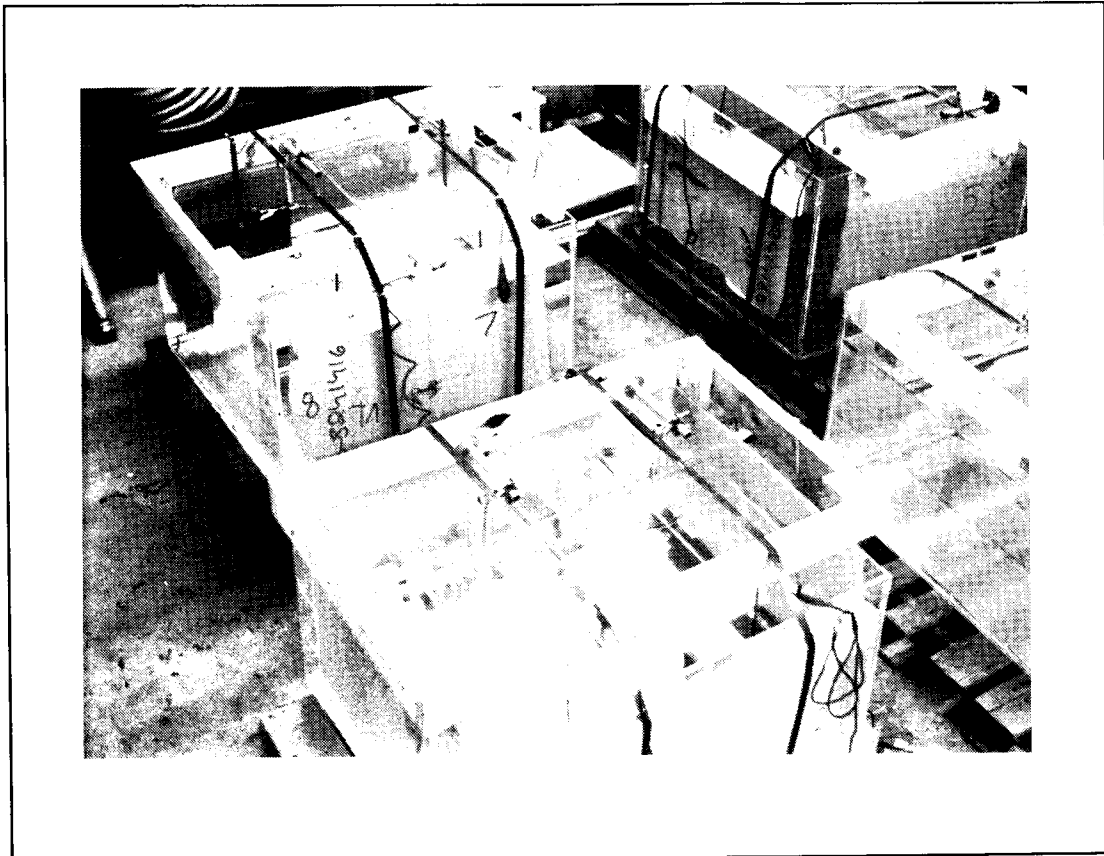

Figure 11. Experimental CP systems.

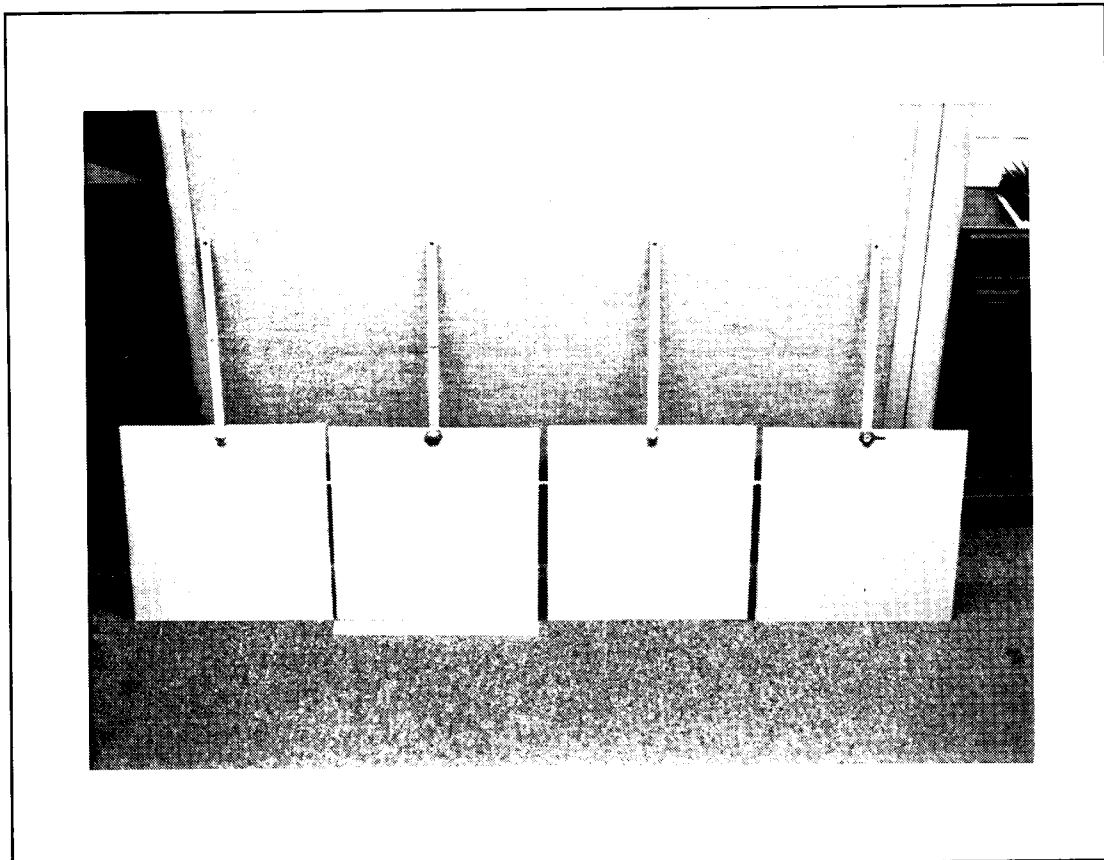

Figure 12. Steel plates used in laboratory experiment.

Table 1. Native potentials for experimental steel plates.

Tank #	Native Potential*
1	-477 mV
2	-482 mV
3	-470 mV
4	-493 mV

*Referenced to copper/copper sulfate half cells.

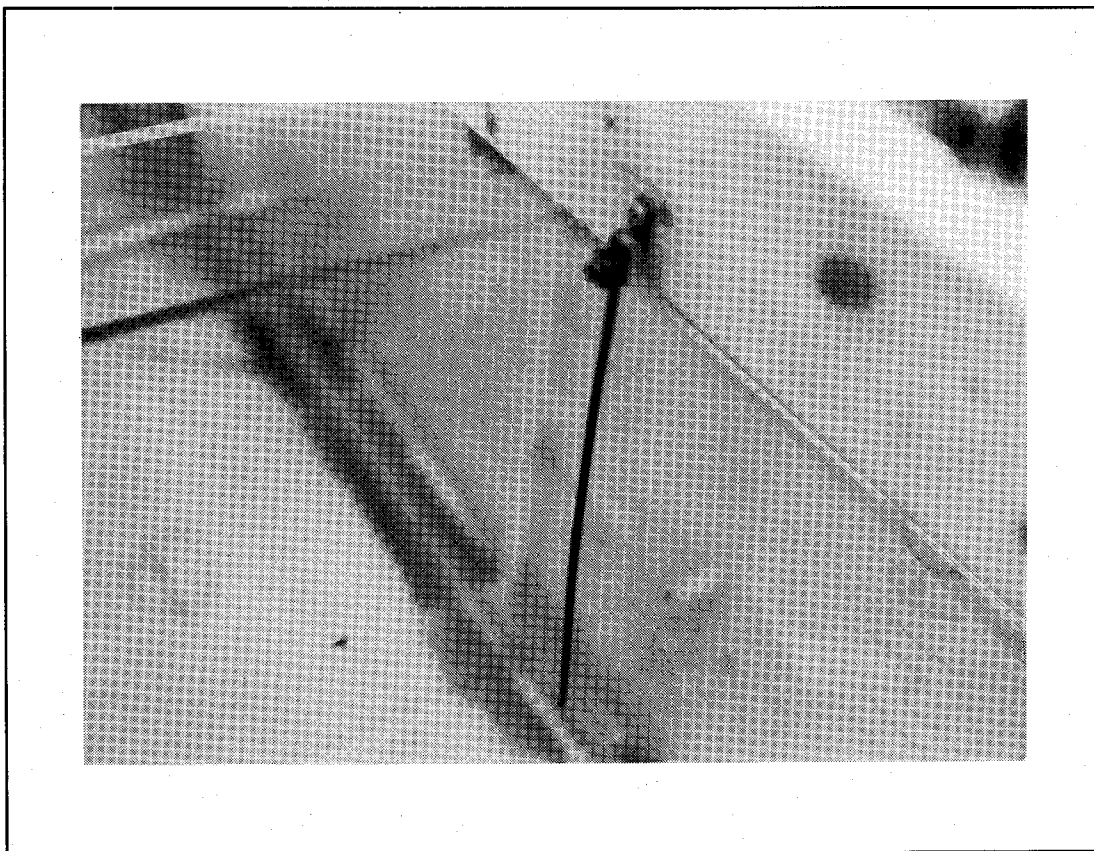

Figure 13. Ceramic-coated rod anode used in laboratory tests.

Table 2. Power sources used in laboratory tests.

Tank No.	Power Source
1	Constant voltage GoodAll tap-adjust full-wave rectifier
2	Photovoltaic panel
3	VADC switchmode filtered rectifier
4	Hewlett Packard Laboratory DC power source

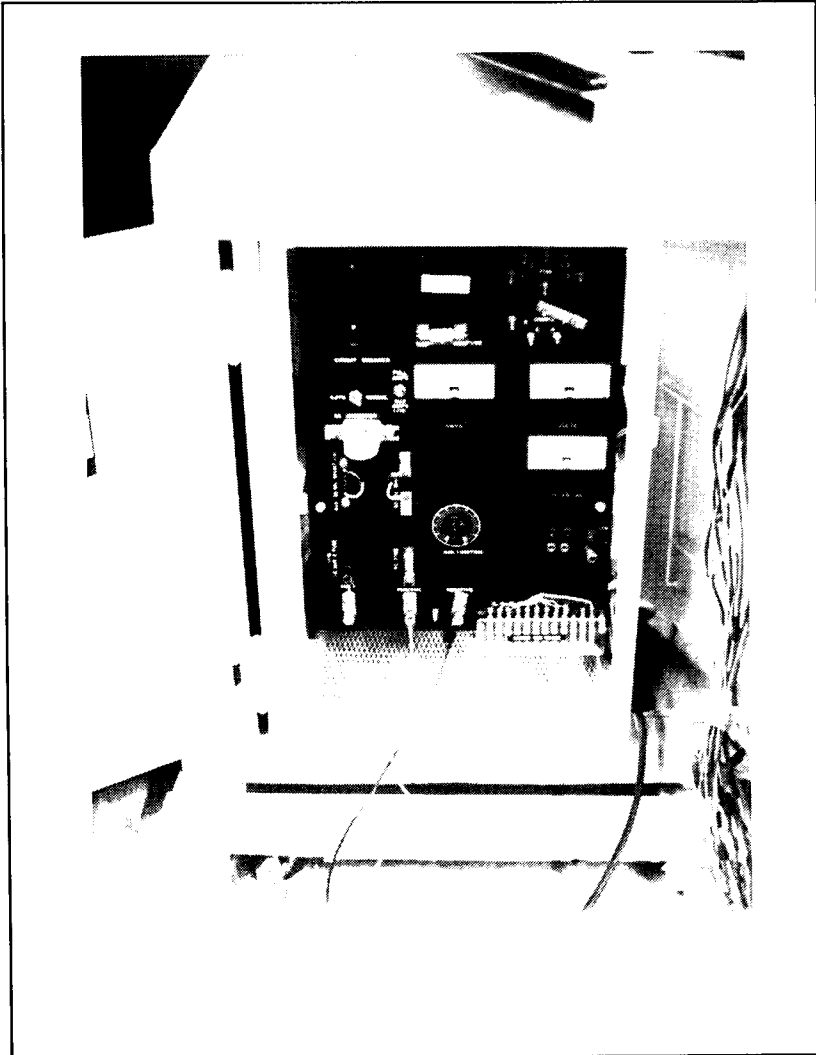

Figure 14. GoodAll rectifier (Tank 1).

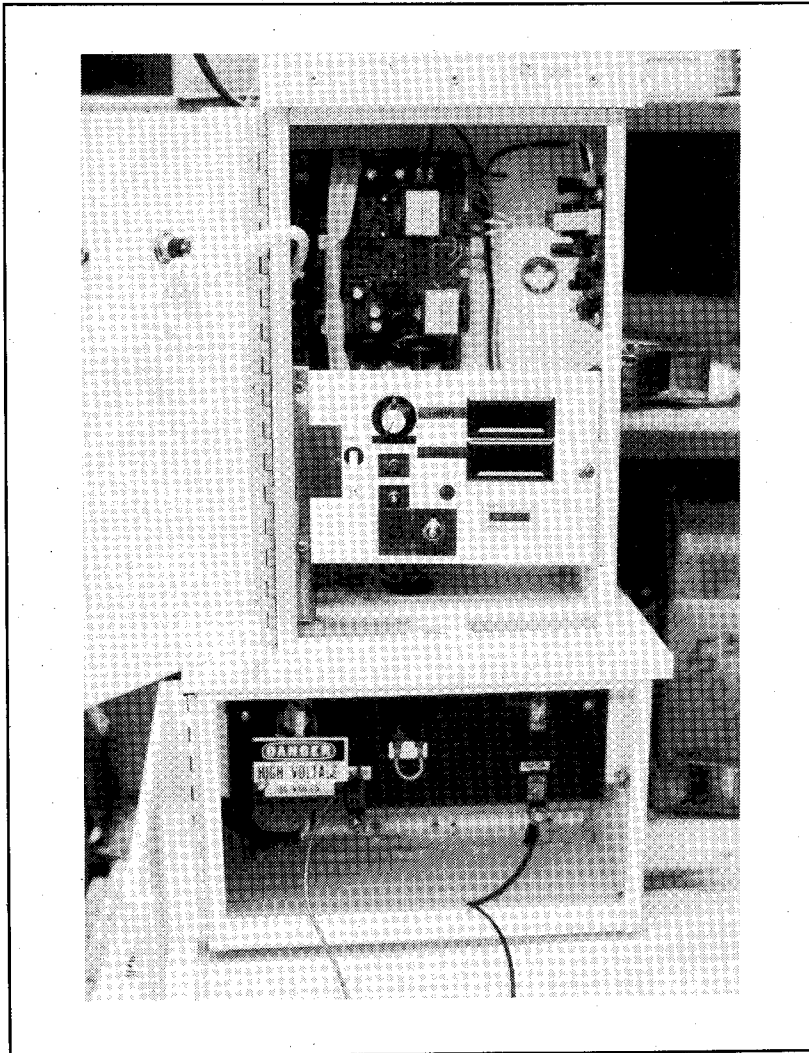

Figure 15. VADC rectifier (Tank 3).

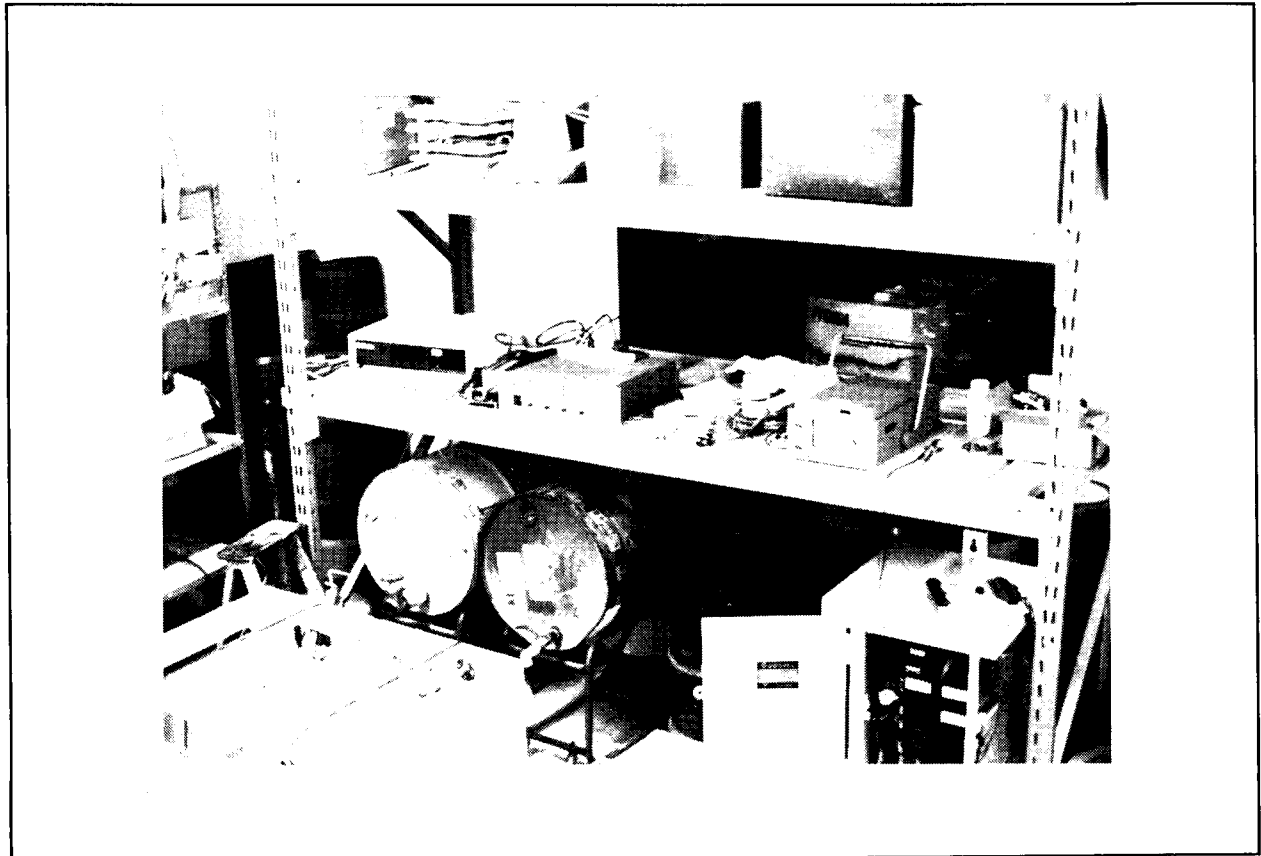

Figure 16. Hewlett Packard DC power source (Tank 4).

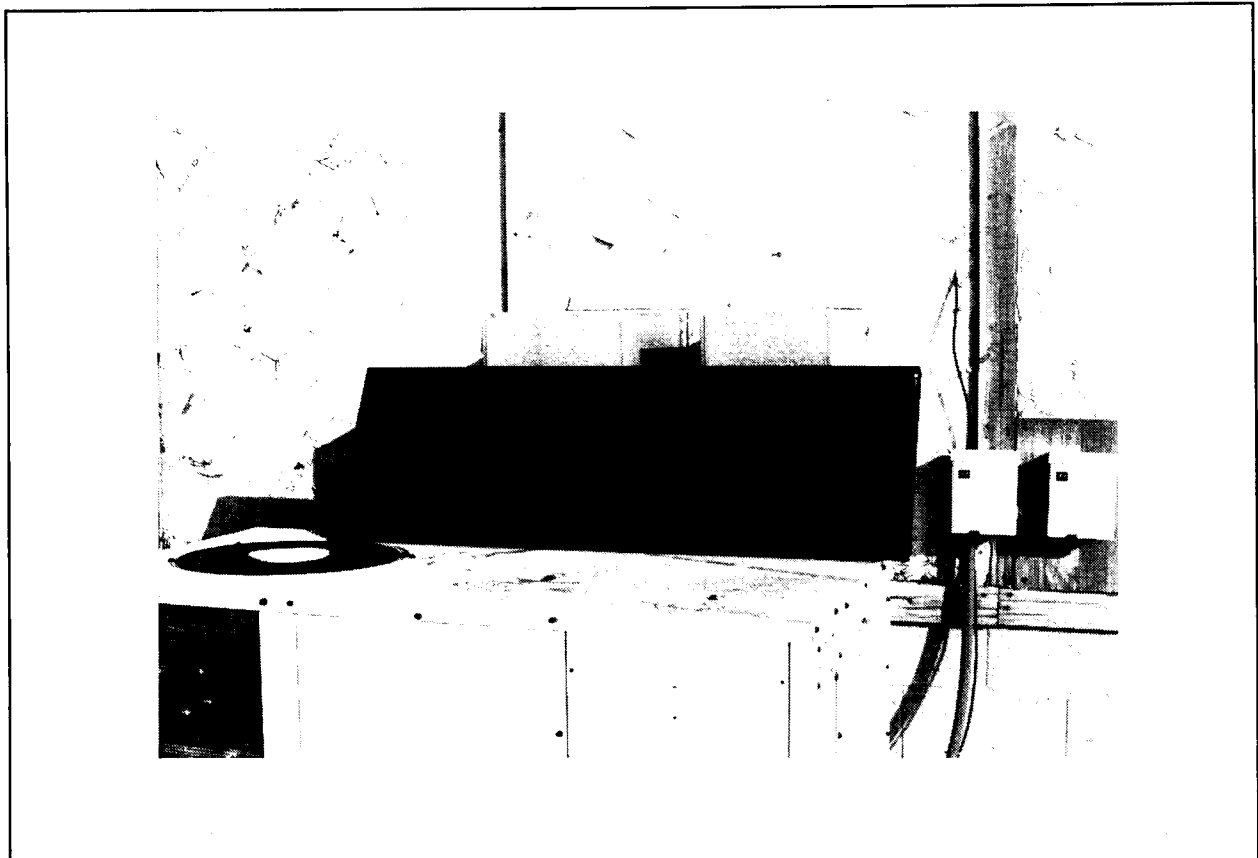

Figure 17. Photovoltaic panel (Tank 2).

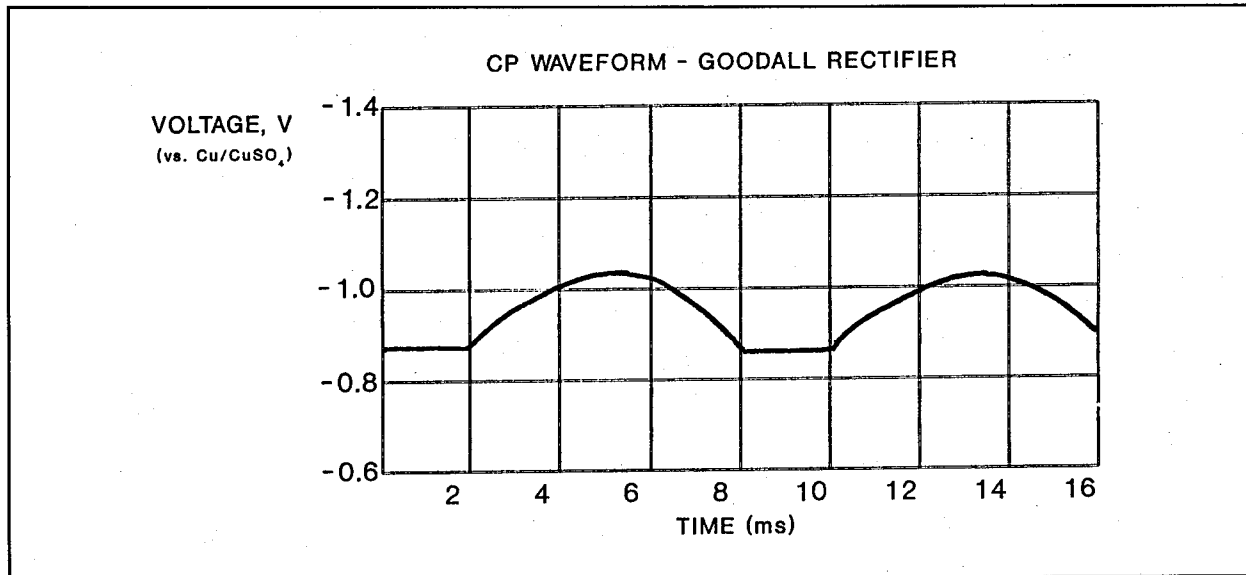

Figure 18. Full-wave rectified waveform from Tank 1.

Table 3. Potential voltage measurements for Tank 1.

Oscilloscope		Cathodic Protection Analyzer (CPA)				Waveform Analyzer (WFA)		Fluke (DMM) On	Vout +V
Max	Min	Max	Avg	Min	SP1	On	Off		
-0.926	-0.840	-0.932	-0.884	-0.845	-0.839	-0.879	-0.844	-0.878	3.112
-0.880	-0.796	-0.875	-0.833	-0.796	-0.772	-0.832	-0.797	-0.832	3.063
-0.936	-0.862	-0.938	-0.894	-0.860	-0.854	-0.882	0.848	-0.884	3.095
-0.892	-0.810	-0.895	-0.850	-0.810	-0.810	-0.812	-0.845	-0.845	3.085
-0.920	-0.838	-0.918	-0.875	-0.836	-0.853	-0.872	-0.835	-0.873	3.068
-0.952	-0.856	-0.951	-0.900	-0.857	-0.868	-0.895	-0.859	-0.896	3.074
-0.880	-0.778	-0.883	-0.829	-0.782	-0.784	-0.823	-0.784	-0.822	3.086
-0.868	-0.766	-0.863	-0.810	-0.763	-0.769	-0.805	-0.765	-0.807	3.106

Table 4. Potential measurements by reference cell position for Tank 1.

Trial	Dist. (in.)	Scope Min	Fluke (DMM) On	Waveform Analyzer (WFA)		Xetron (CPA 730)	
				On	Off	Min	SP1
#1	0.5	-0.830	-0.880	-0.868	-0.833	-0.817	-0.811
	9.0	-0.836	-1.073	-1.068	-0.834	-0.830	-0.974
	18.0	-0.838	-1.291	-1.263	-0.835	-0.839	-1.105
#2	0.5	-0.832	-0.878	-0.856	-0.827	-0.815	-0.818
	9.0	-0.840	-1.079	-1.074	-0.833	-0.829	-0.982
	18.0	-0.840	-1.288	-1.270	-0.833	-0.827	-1.105

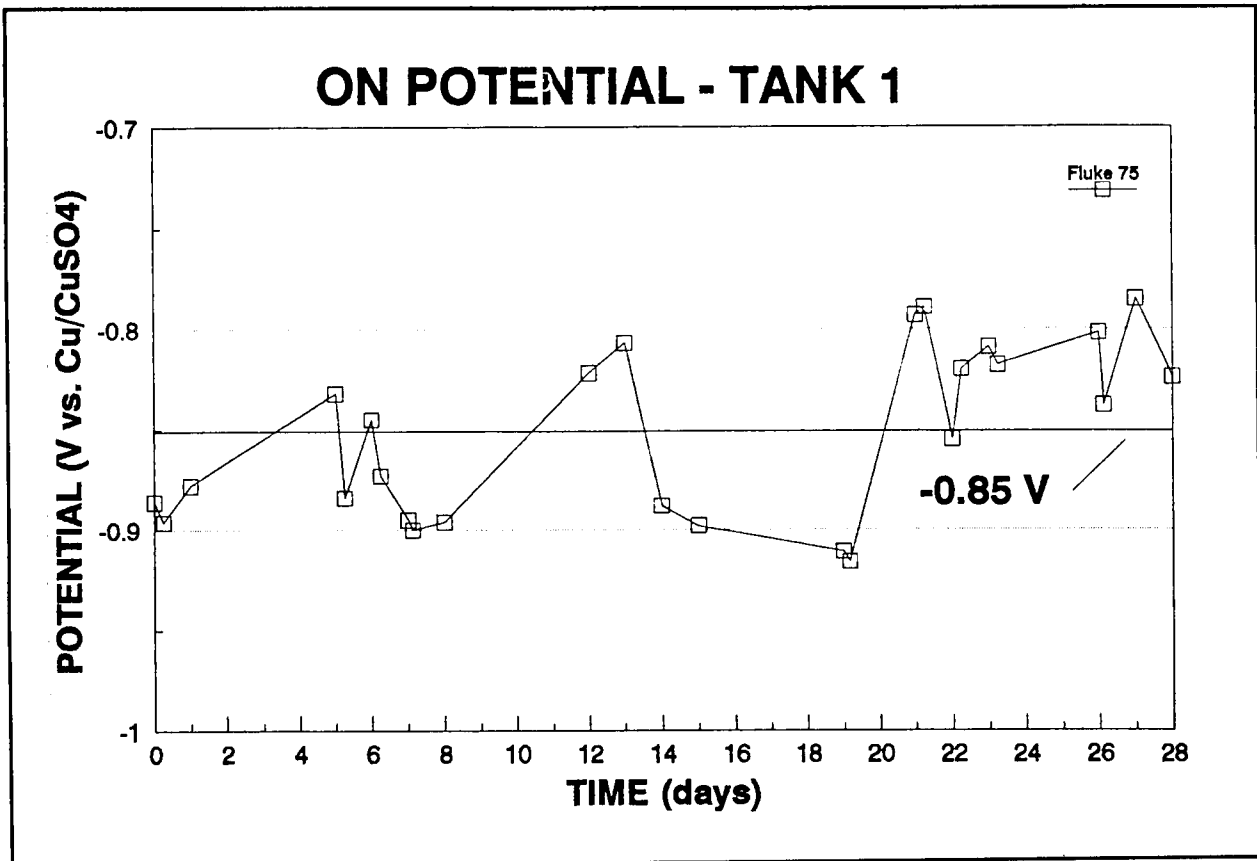

Figure 19. On-potentials vs. time for Tank 1.

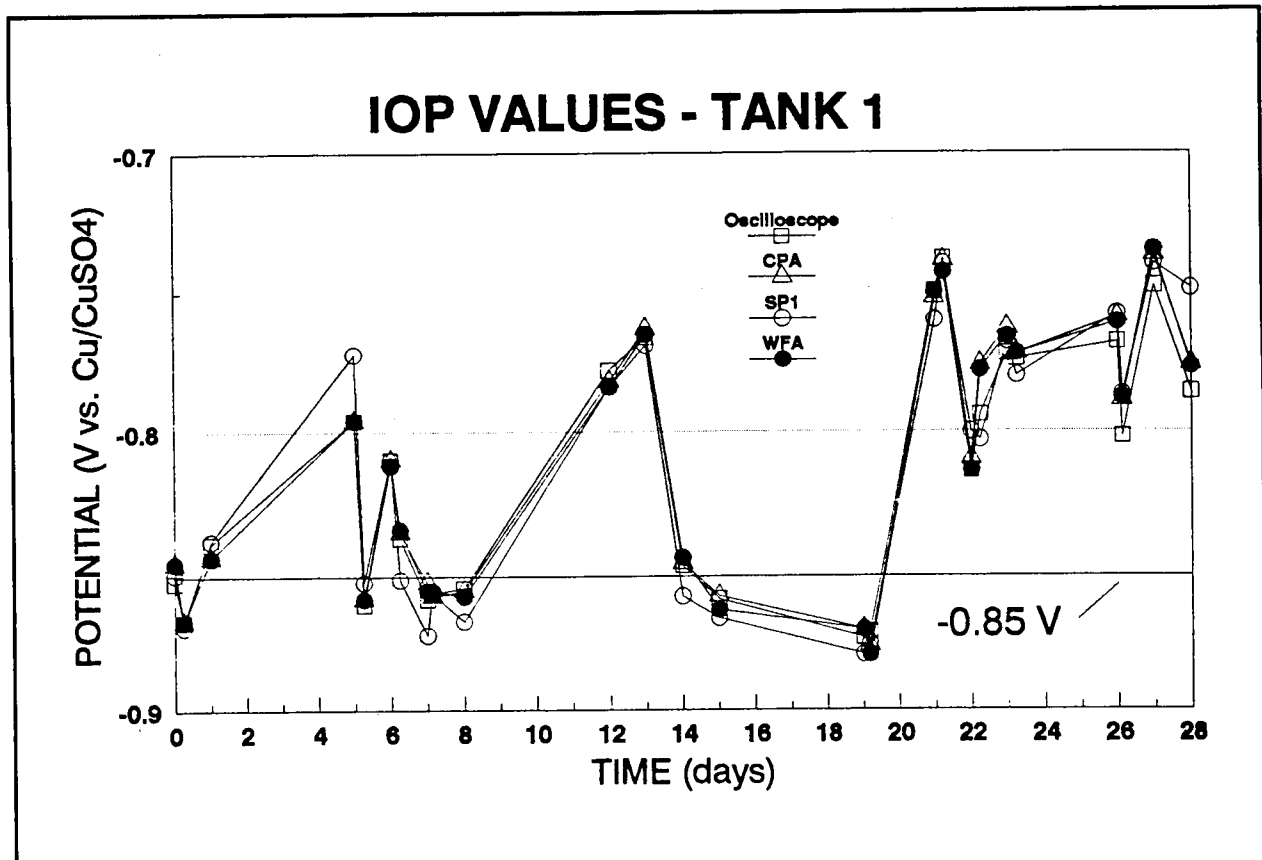

Figure 20. Off-potentials vs. time for Tank 1.

CP WAVEFORM - VADC RECTIFIER

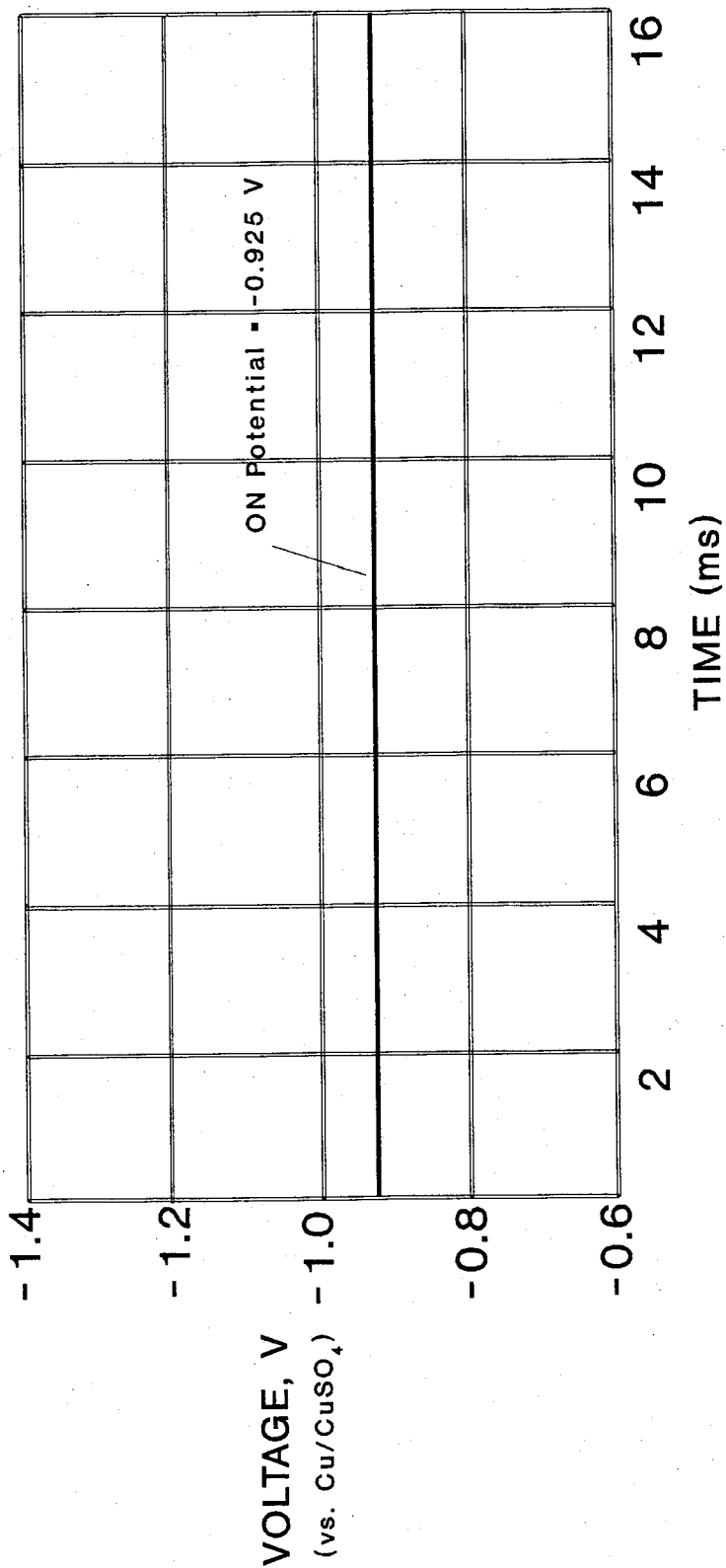

Figure 21. CP waveform from Tank 3.

Table 5. Potential measurements for Tank 3.

Fluke (DMM)	Waveform Analyzer (WFA)		CPA/ SP1
	On	Off	Off
-0.912	-0.905	-0.855	-0.875
-0.897	-0.898	-0.846	-0.856
-0.862	-0.856	-0.816	-0.838
-0.841	-0.839	-0.791	-0.816
-0.879	-0.878	-0.826	-0.836
-0.838	-0.838	-0.789	-0.808
-0.873	-0.872	-0.822	-0.833
-0.865	-0.861	-0.812	-0.856

Table 6. Potential measurements by reference cell position for Tank 3.

Trial	Dist. (in.)	Fluke (DMM)	Waveform Analyzer (WFA)		CPA/ SP1
		On	On	Off	Off
#1	0.5	-0.885	-0.893	-0.827	-0.833
	9.0	-1.103	-1.092	-0.824	-0.981
	18.0	-1.340	-1.334	-0.827	-1.088
#2	0.5	-0.883	-0.887	-0.831	-0.844
	9.0	-1.091	-1.091	-0.817	-0.977
	18.0	-1.316	-1.330	-0.822	-1.094

Table 7. Potential measurements for Tank 4.

Fluke (DMM)	Waveform Analyzer (WFA)		CPA/SP1
	On	Off	Off
-0.924	-0.917	-0.867	-0.894
-0.918	-0.916	-0.866	-0.897
-0.848	-0.837	-0.788	-0.839
-0.829	-0.824	-0.778	-0.813
-0.884	-0.882	-0.835	-0.862
-0.833	-0.833	-0.782	-0.821
-0.866	-0.866	-0.815	-0.835
-0.886	-0.882	-0.831	-0.892

Table 8. Potential measurements by reference cell position for Tank 4.

Trial	Dist. (in.)	Fluke (DMM)	Waveform Analyzer (WFA)		CPA/SP1
		On	On	Off	Off
#1	0.5	-0.912	-0.899	-0.878	-0.830
	9.0	-1.028	-0.983	-0.873	-0.923
	18.0	-1.140	-1.143	-0.880	-1.000
#2	0.5	-0.907	-0.889	-0.867	-0.836
	9.0	-1.008	-0.998	-0.875	-0.927
	18.0	-1.132	-1.116	-0.872	-1.009

Table 9. Potential measurements for Tank 2.

Fluke (DMM)	Waveform Analyzer (WFA)		CPA/ SP1
On	On	Off	Off
-0.810	-0.813	-0.742	-0.803
-0.812	-0.815	-0.767	-0.805
-0.817	-0.823	-0.745	-0.816
-0.836	-0.836	-0.749	-0.840
-0.854	-0.868	-0.766	-0.831
-0.804	-0.800	-0.744	-0.804
-0.867	-0.872	-0.778	-0.845
-0.810	-0.822	-0.756	-0.832

Table 10. Potential measurements by reference cell positions for Tank 2.

Trial	Dist. (in.)	Fluke (DMM)	Waveform Analyzer (WFA)		CPA/SP1
		On	On	Off	Off
#1	0.5	-0.866	-0.867	-0.851	-0.794
	9.0	-0.964	-0.951	-0.846	-0.857
	18.0	-1.058	-1.047	-0.844	-0.930
#2	0.5	-0.865	-0.869	-0.850	-0.795
	9.0	-0.951	-0.957	-0.839	-0.865
	18.0	-1.050	-1.052	-0.836	-0.925

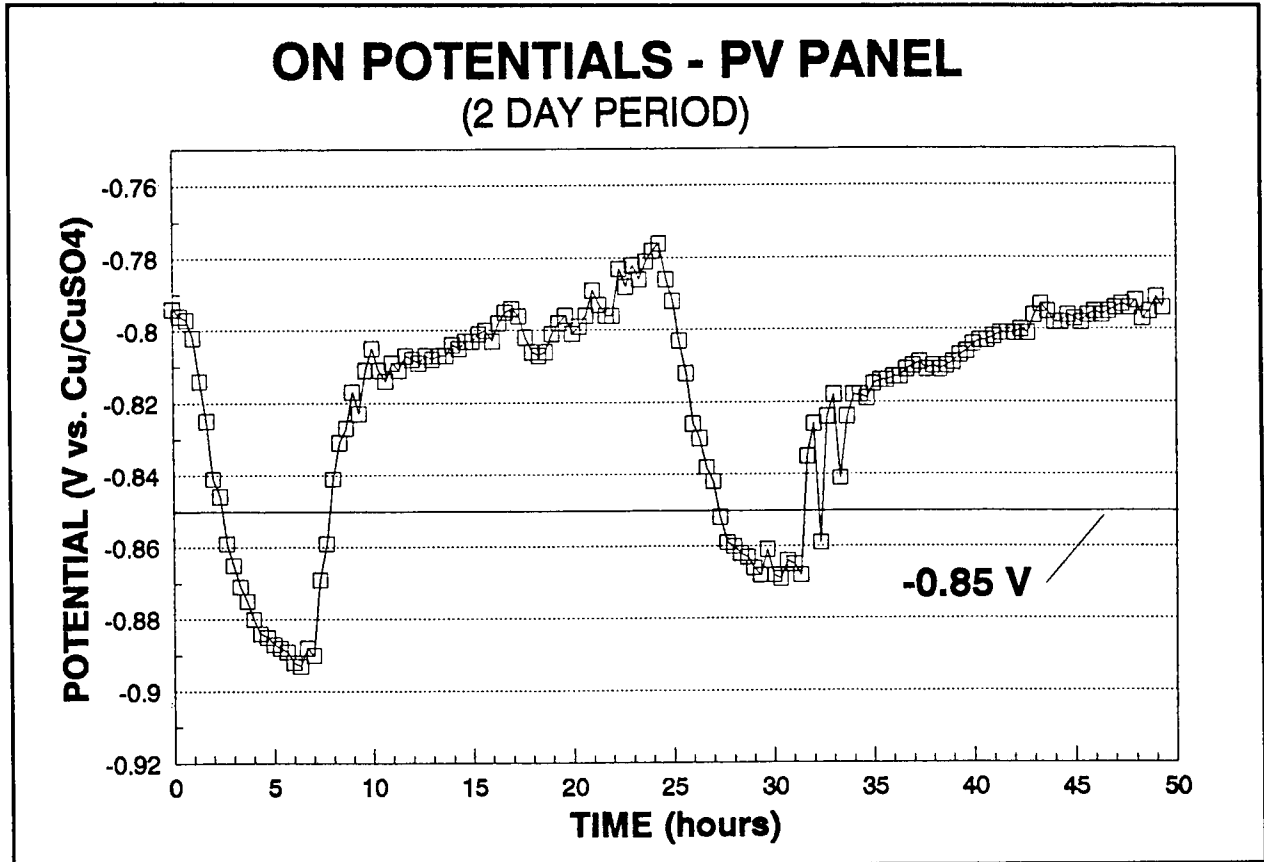

Figure 22. On-potential vs. time for photovoltaic panel for 48-hour period.

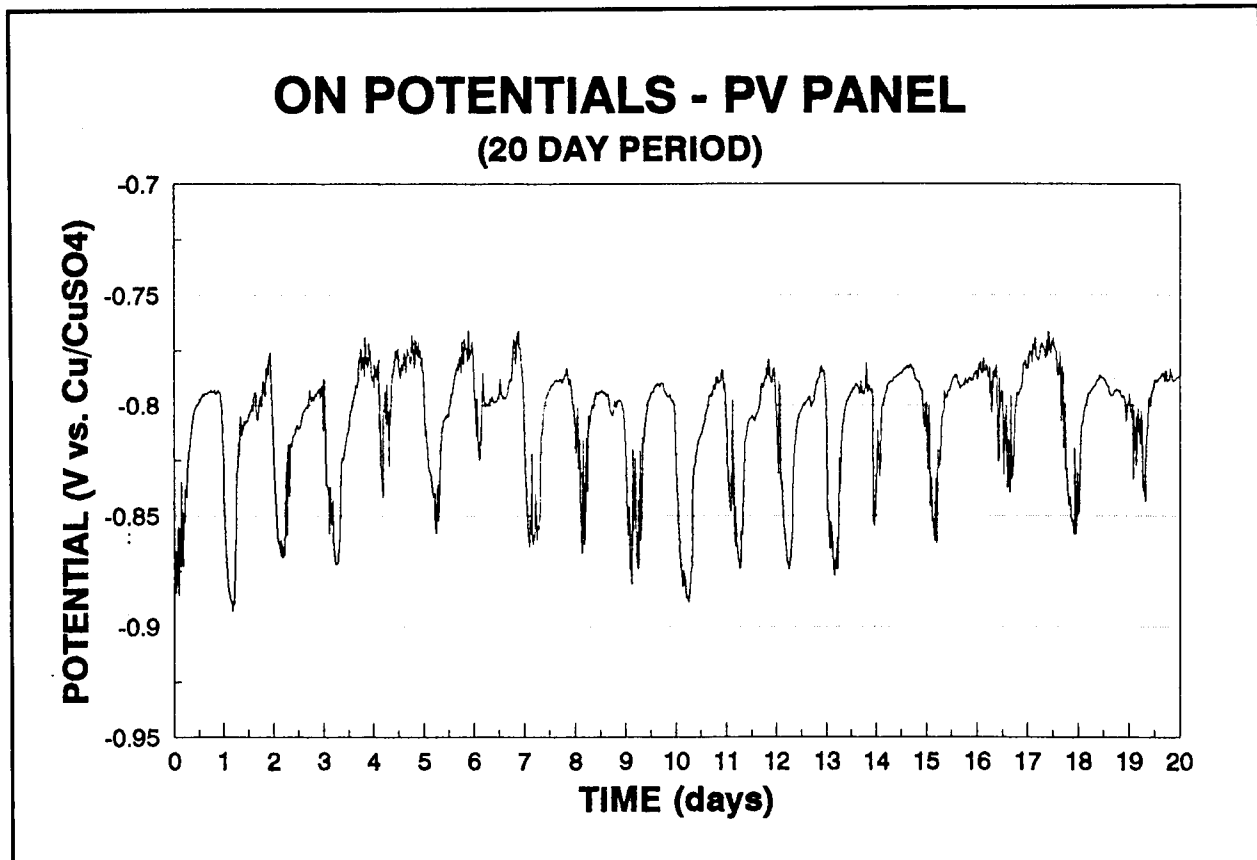

Figure 23. On-potential vs. time for photovoltaic panel for 20-day period.

6 Field Tests

Three sites were chosen for field tests of offpotential measurement devices. The underground fuel storage tank at Fort Lee, VA, and the elevated water storage tanks at Fort Hood, TX were chosen for this study because data were already available from a previous site study (Evans 1989; Corrpro 1989). Additionally, underground pipeline systems were evaluated in Tucson, AZ from Santa Fe Pacific Pipelines.

Underground Fuel Storage Tank—Fort Lee, VA

Background

During September 1989, an impressed current cathodic protection system using ceramic anode canisters was installed on a 5000-gal underground fuel storage tank.* Prior to the design of the CP system, preliminary field data were collected, which included soil resistivity, native structure-to-soil potentials, electrical continuity, and current requirement tests.

Measurements were made using a Nilsson Model 400 resistivity meter and the Wenner Four-Electrode Method to obtain the soil resistivity at depths of 5, 10, and 15 ft (Figure 24). The average soil resistivity values obtained ranged from 11,970 ohm-cm to 62,000 ohm-cm at a 2.5-ft depth; 12,500 ohm-cm to 23,900 ohm-cm at a 5-ft depth; and 10,000 ohm-cm to 19,100 ohm-cm at a 10-ft depth (Table 11). This range of soil resistivity values indicates that the structure is in a moderately corrosive environment. In addition, a chemical analysis of the soil was conducted, and a significant level of chloride ions in the soil (300 mg/L) was found. Soil pH was 4.9 (acidic). The resistivity value of the deionized water saturated sample was 6000 ohm-cm.

“Native” structure-to-soil potential measurements were performed at representative locations around the storage tank and associated piping. The measurements were obtained by using a copper-copper sulfate (Cu/CuSo₄) reference electrode placed in contact with the soil over the structure and a direct contact to the structure through the use of a high impedance digital voltmeter. The “native” structure-to-soil potential

* 1 gal = 3.78L; 1 ft = 0.305 m.

measurements (Table 12) ranged from -286 millivolts to -434 millivolts. These values indicate levels much lower than expected for carbon steel. (Lower numbers usually mean buried copper.)

A temporary cathodic protection system was used to simulate a permanent system. The temporary CP system consisted of rods driven around the tank and a portable test rectifier (Figure 25). Structure-to-soil potential was measured with the cathodic protection system cycling on and off (Table 13) to gauge the effectiveness of applying cathodic protection current. The average potential change as a result of applying cathodic protection current from the temporary groundbed was about 74 millivolts polarization.

An impressed current CP system was designed and specifications were prepared based on the preliminary field data. Figure 26 shows a typical ceramic-coated anode canister used in the CP system. Such ceramic-coated anode canisters consist of a mixed metal oxide-coated, 1/8- to 1/4-in. diameter titanium rod, surrounded by calcined fluid petroleum coke breeze. The canisters are lightweight, averaging from 6 to 44 lb depending on size, which can vary from a minimum of 2-in. diameter x 30-in. length to a maximum of 3-in. diameter x 120-in. length, and are well suited for use in underground applications (Hock 1992a, 1992b).

Figure 27 shows the layout of the CP system. The rectifier was energized during September 1989. The structure-to-soil off-potential on the southeast side of the tank was -0.71 volts relative to a copper-copper sulfate electrode. The rectifier output was set at 19.3 V DC and 0.7 A DC. After allowing time for polarization of the structure, the final rectifier adjustments were made. Table 12 lists the structure-to-soil potential measurements at time of CP system energization. The data show that the 100 millivolt polarization decay criteria was satisfied.

Procedure and Results

To measure the entire cathodic protection voltage in real time, a full-wave unfiltered rectifier, similar in design to the tank 1 rectifier used in the laboratory test (outlined in Chapter 5), was selected for the CP power supply. This allowed IOP readings to be recorded a fraction of a millisecond after the full wave unfiltered rectifier went to zero. The potential difference between the cathodically protected tank and a copper-copper sulfate reference electrode were measured.

The CPA Model 730 and the WFA-1 were used to measure instant off-potentials. The results were compared to measurements obtained using a Leader LCD-100 digital storage oscilloscope in conjunction with the appropriate voltage offset circuitry to

provide a 10mV resolution. In addition, a Fluke Model 75 Digital Voltmeter with an 11 megohm input resistance was also used in conjunction with a current interrupter. Current was interrupted and the second DVM display update was recorded as the interrupted instant off-potential.

The data presented in Table 14 show the relationship between the various methods of measuring the on, off, and instant off-potential. Figure 28 shows actual amplified oscilloscope traces of the CP waveform. When the oscilloscope measurement is only a fraction of a second into the polarization decay, it is the most negative or closest to the true IOP. The minimum measurements obtained by the CPA 730, which represent the IOP, varied by less than 1 percent from the minimum oscilloscope readings, indicating the CPA is reading essentially the same point on the polarization decay curve. Any slight difference is due to measurement error or noise. The difference however, does not appear to be significant.

As measured by the WFA-1, the difference between the IOP and the oscilloscope IOP varied between 34 and 141 millivolts. It appears that the WFA-1 is measuring a point lower down on the polarization decay curve than the oscilloscope. However, for this particular cathodically protected structure, the difference is not significant.

The worst case or lowest point on the decay curve was obtained by measuring the off-potential using an interrupted DVM method. The difference varied from 130 to 280 millivolts. Although the interrupted off-potential values satisfied both NACE criteria, the potential for coating damage exists since the true IOP obtained by the oscilloscope shows two potential measurements in excess of $-1.2V$ at locations 2 and 4 on the tank.

Elevated Water Storage Tanks—Fort Hood, TX

Background

In designing a cathodic protection system for an elevated water storage tank, the size and shape of the tank directly determine the number of anodes and length of each anode necessary to protect the tank bowl. To maximize the effectiveness of the system, the height of the tank riser pipe must be known. From this, the length of the anode necessary to supply complete cathodic protection can be determined. The tank coating condition and its uniformity also affect anode spacing.

Under the Facilities Engineering Application Program (FEAP), a cathodic protection system using ceramic-coated anodes was installed in 1988 at Fort Hood, TX. Two water storage tanks (#1673 and #4001) were chosen as demonstration sites for the

system. Both tanks use identical system designs—six bowl anode strings, three stub anode strings, and one riser string (Figure 29), and detailed in ETL 1110-9-10(FR), sections 2-6 and 2-7.

Based on the performance of the ceramic-coated anodes in the demonstration tanks, the Fort Hood Directorate of Engineering and Housing (DEH) personnel installed a CP system in June 1989 using ceramic-coated anodes on another elevated water storage tank, #4655. All the anodes in this tank are supported by clevis-connector cables tied to a porcelain insulator on the inside of the tank's roof. The bowl anode segments consist of 120-cm solid titanium rods. There are no riser anodes in tank #4655 because the diameter of the riser pipe is less than 30 in. (and was not accessible). The rectifier used was a Wallace Tiernan 10V, 10A constant voltage tap-adjust, rectifier powered by 120V AC line power. This rectifier is similar in design to the tank 1 rectifier used in laboratory testing.

Procedure and Results

Tank-to-water potential measurements were taken on tank #4655 in the summers of 1990, 1991, and 1992. The 1990 measurements were taken with a Nilsson Model 510A analog voltmeter. These readings are only on or average potentials. The potential measurements were all around -1100 mV, indicating protection (Appendix B, p 65). IR drop error is present in these readings, so actual polarized potentials of the tank are not as negative. The tank interior was reported to be in very good condition. The 1991 measurements were taken with the same Nilsson Model 510A voltmeter and a M.C. Miller Model CI-30 current interrupter. These readings include both on- and off-potentials. The on readings were all quite close to -850 mV, and the off readings were all around -750 mV (Appendix B, p 66). Since the tank interior was reported to be in good condition, the interrupted off measurements may reveal depolarization of the structure during measurement.

Before the 1992 readings were taken, the rectifier tap settings were slightly adjusted to comply with the NACE criteria of -850 mV. Since the CP power source is a constant output rectifier, the adjustments were necessary due to changes in the system environment, such as a varying water level in the tank.

In the summer of 1992, the measurements were taken with the CPA Model 730. The negative lead was clamped to the tank at an access port at the top of the tank, and a copper/copper sulfate reference cell was lowered through other access ports to take readings at locations A-J. The off-potential measurements indicate complete protection is being achieved (Appendix B).

Underground Pipeline Systems—Tucson, AZ

Background

Underground petroleum pipelines of the Santa Fe Pacific Pipelines network were evaluated in Tucson, AZ. The pipeline system selected for testing consisted of three separate parallel lines of 6, 8, and 12 in. in diameter. The three separate pipelines were of varying age and coating conditions. The oldest line (6-in. diameter) was about 35 years old and poorly coated. The 12-in. line has been in use for approximately 2 years, and is well coated. The 8-in. line has a moderate coating condition. Each of the lines were cathodically protected using impressed current CP systems with constant current rectifiers.

An initial potential survey was conducted in early 1993 along approximately 25 miles of the pipeline system. On-potentials were recorded at various test stations located along the 25-mile stretch. The results showed regions along each pipeline of varying structure-to-soil potentials, indicating some areas of pipe were not being adequately protected.

Procedure and Results

Based on the initial potential survey, a 5.4-mile section between two rectifiers was chosen for evaluation. This section will be denoted as mile markers 319.6 through 325.0. The potential survey revealed on-potentials with fluctuations exceeding 500 mV in some cases. Potential measurements were taken at 14 test stations along this section on each of the three parallel lines (6, 8, and 12-in. diameters).

Before measurements were taken, pulse generators were installed in five rectifiers along the 25-mile section of pipeline. Beginning at one rectifier, on-potentials were taken with a Fluke 75 Digital Multimeter and on- and off-potentials were taken with the WFA-1 and a Polycorder. The Polycorder uses the same algorithm as the WFA-1 for calculating on- and off-potentials (See Chapter 4). Readings were at the various test stations upon reaching the next rectifier. The five pulse generators were then set for no current interruption. Measurements at the same test stations were repeated with the Xetron CPA 730 and SP1 probe to record maximum, average, and minimum potentials. The SP1 probe was used in both high and normal modes.

The data presented in Tables 15 to 17 show the relationships between the various instrumentation systems for the 6, 8, and 12-in. diameter pipelines, respectively.

Based on the results of the off-potential measurements, adequate protection was being achieved for the 12-in. pipeline for approximately half of the 5.4-mile section under consideration (based on the 850 mV NACE criteria). Readings taken on the 6 and 8-in. lines show that the 850 mV criteria is being met on very few test points, and most readings are between -550 and -700 mV. The WFA-1 and Polycorder on and off readings were approximately equal for each pipeline, as expected. The CPA 730 minimum readings were on the average approximately 50 mV more negative than the WFA and Polycorder. SP1 probe readings were in excess of 100 mV more negative for most test points. In regions of the pipeline where protection is not being achieved (i.e., mile markers 321.9 to 325.0 for 6 and 8-in. lines), the on and off values are quite close to each other. This indicates a flatter CP waveform is present. As seen in the data tables, the WFA-1, Polycorder, and CPA 730 readings show close agreement. However, it should be noted that the 850 mV criteria is not being achieved at these test points.

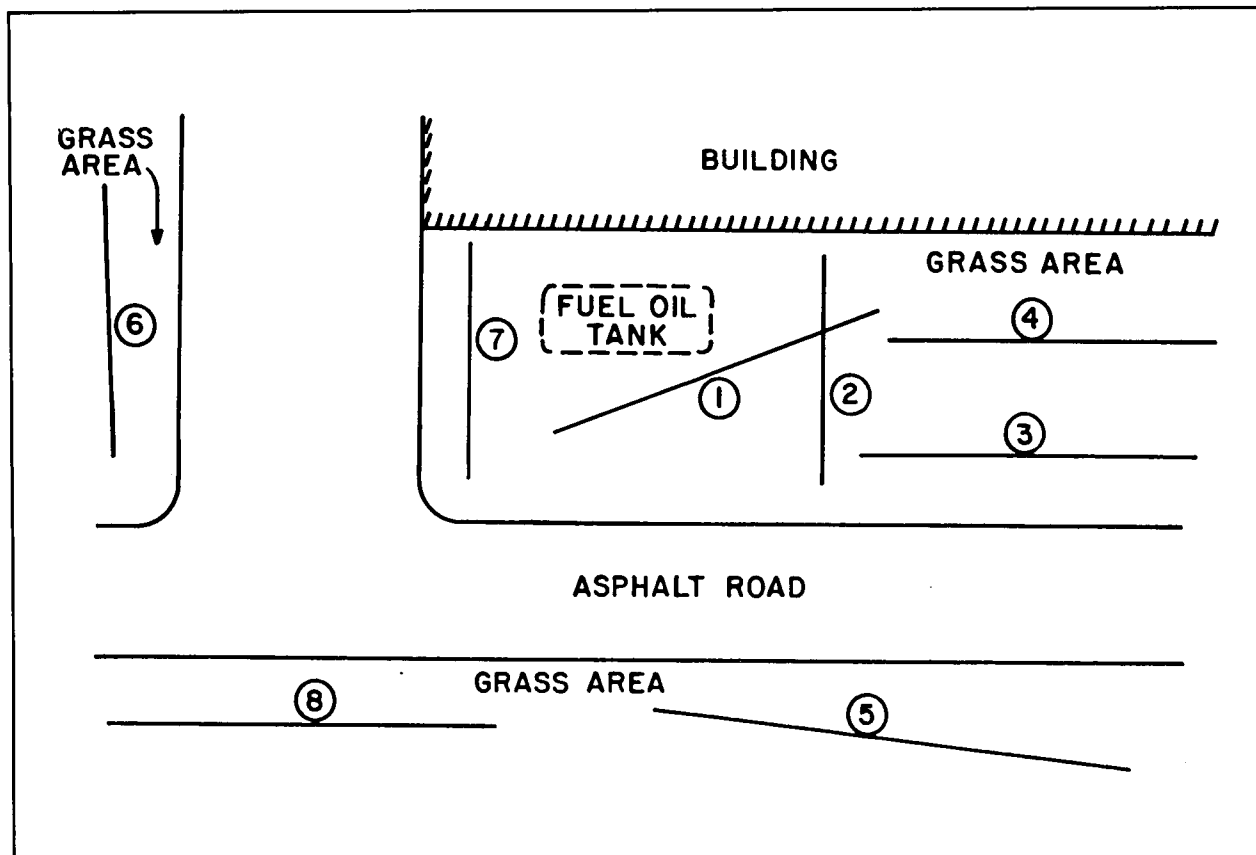

Figure 24. Location of soil resistivity test points using Wenner 4-pin method.

Table 11. Soil resistivity data.

Location	Resistivity in ohm-cm			
	2.5 ft.	5 ft.	10 ft.	5-10 ft. Layer
1	42,600	23,900	16,280	12,344
2	35,430	23,900	17,430	13,716
3	5,480	23,900	13,220	9,137
4	23,000	16,280	16,280	16,280
5	12,500	12,500	19,150	40,918
6	62,000	42,130	18,580	11,918
7	25,400	14,400	10,920	8,794
8	11,970	14,400	18,960	27,746
Average	32,298	21,426	16,353	15,296

Table 12. Structure-to-soil potential measurements at CP system energization (1989).

Location	Native (V)*	On (V)	Off (V)
1	-0.434	-3.7	-0.815
2	-0.405	-1.50	-
3	-0.424	-3.65	-
4	-0.387	-1.82	-
5	-0.286	-1.08	-0.710
6	-0.371	-1.92	-
7	-	-3.35	-0.900

*Rectifier Data:
M.P. Power Systems Model VADCA 40-08Z1-356, S/N MP-89075
Rated Input 115V AC, 5A AC
Rated Output 40V DC, 8A DC
Operating Output 20.0V DC, 0.7A DC

Anode Data:
Anode #1 0.30 A DC
Anode #2 0.40 A DC

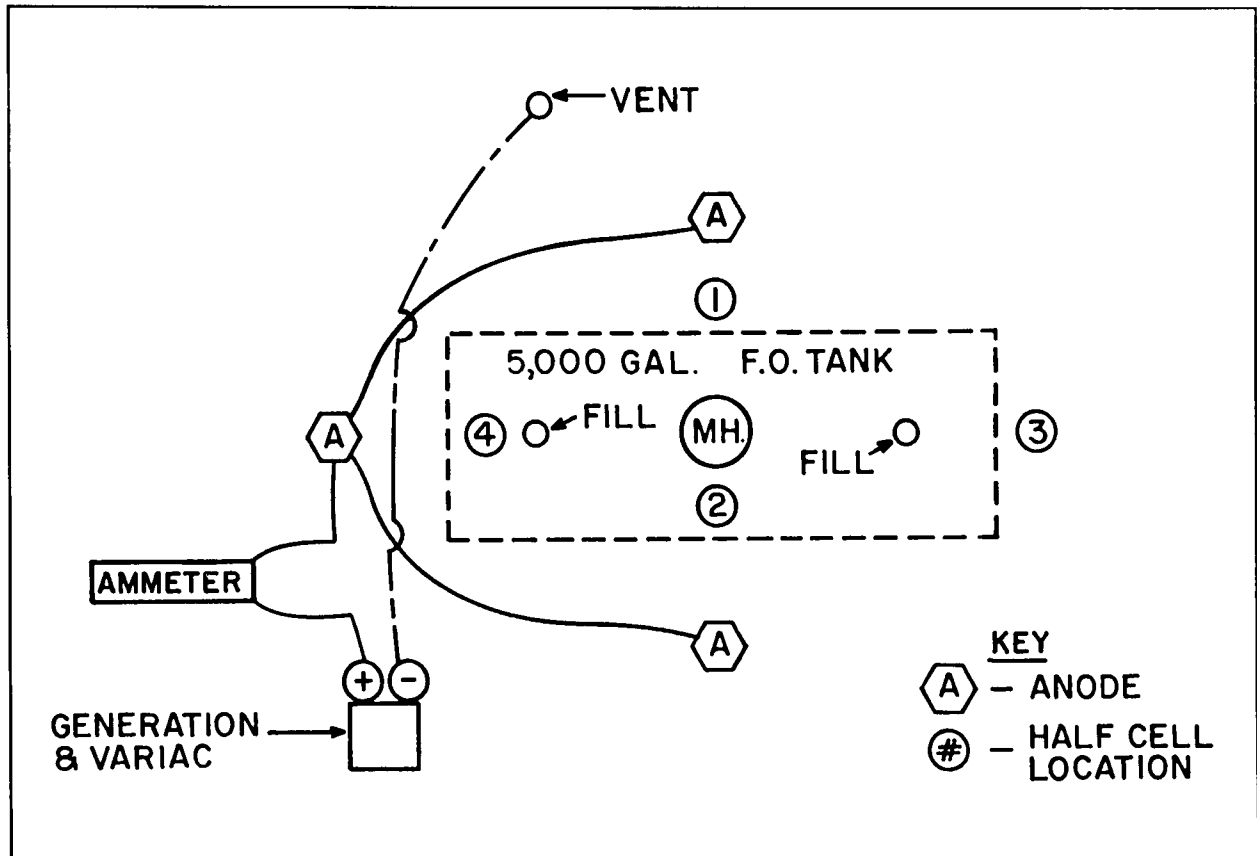

Figure 25. Location of current requirement test points.

Table 13. Current requirements test data.

Pipe-to-Soil Potentials in Millivolts*			
Location	On	Off	Native
1	-841	-400	-286
2	-3600	-500	-380
3	-587	-410	-405
4	-826	-478	-421

*Current Applied = 0.7 A

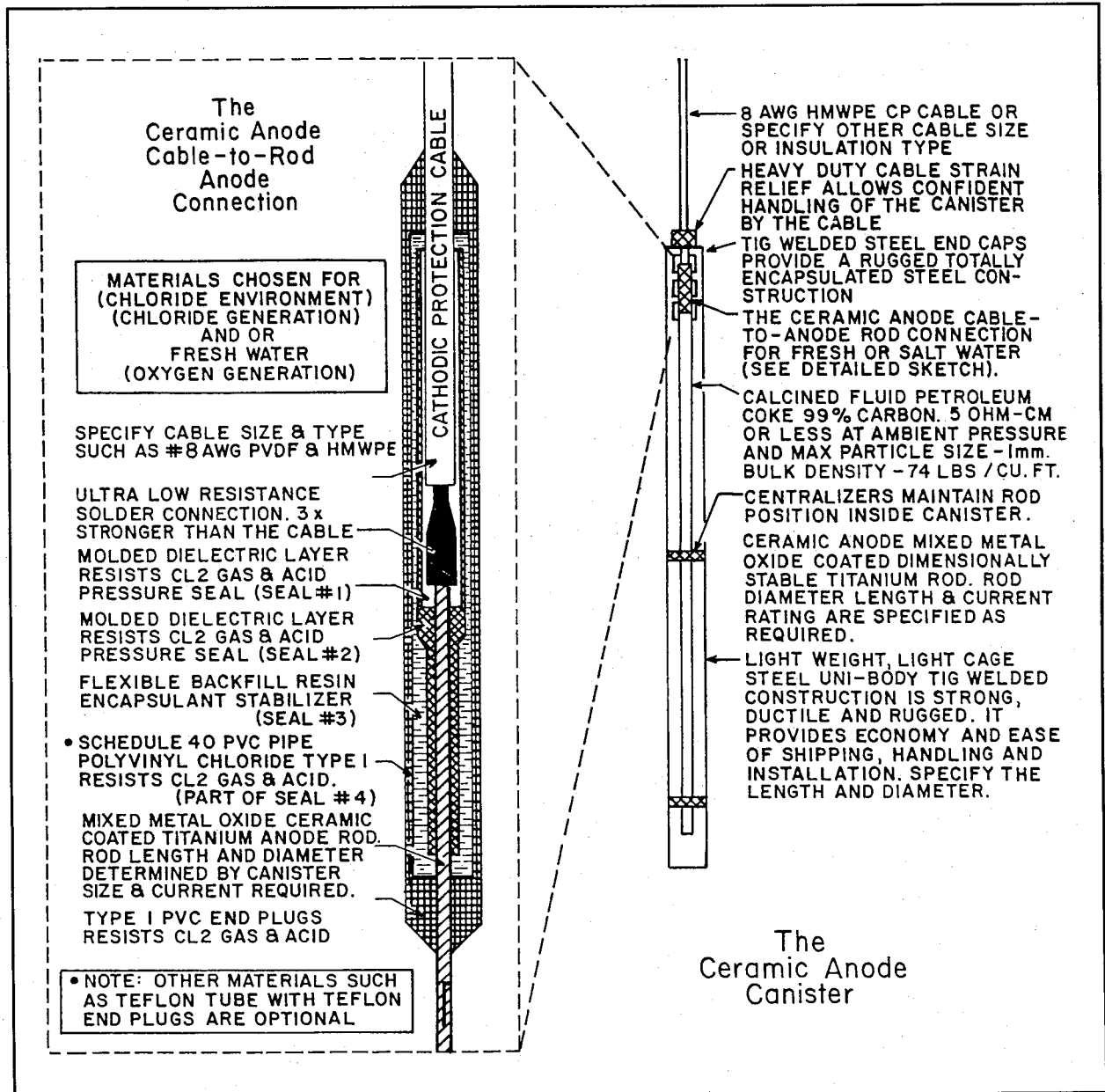

Figure 26. A typical ceramic-coated canister anode.

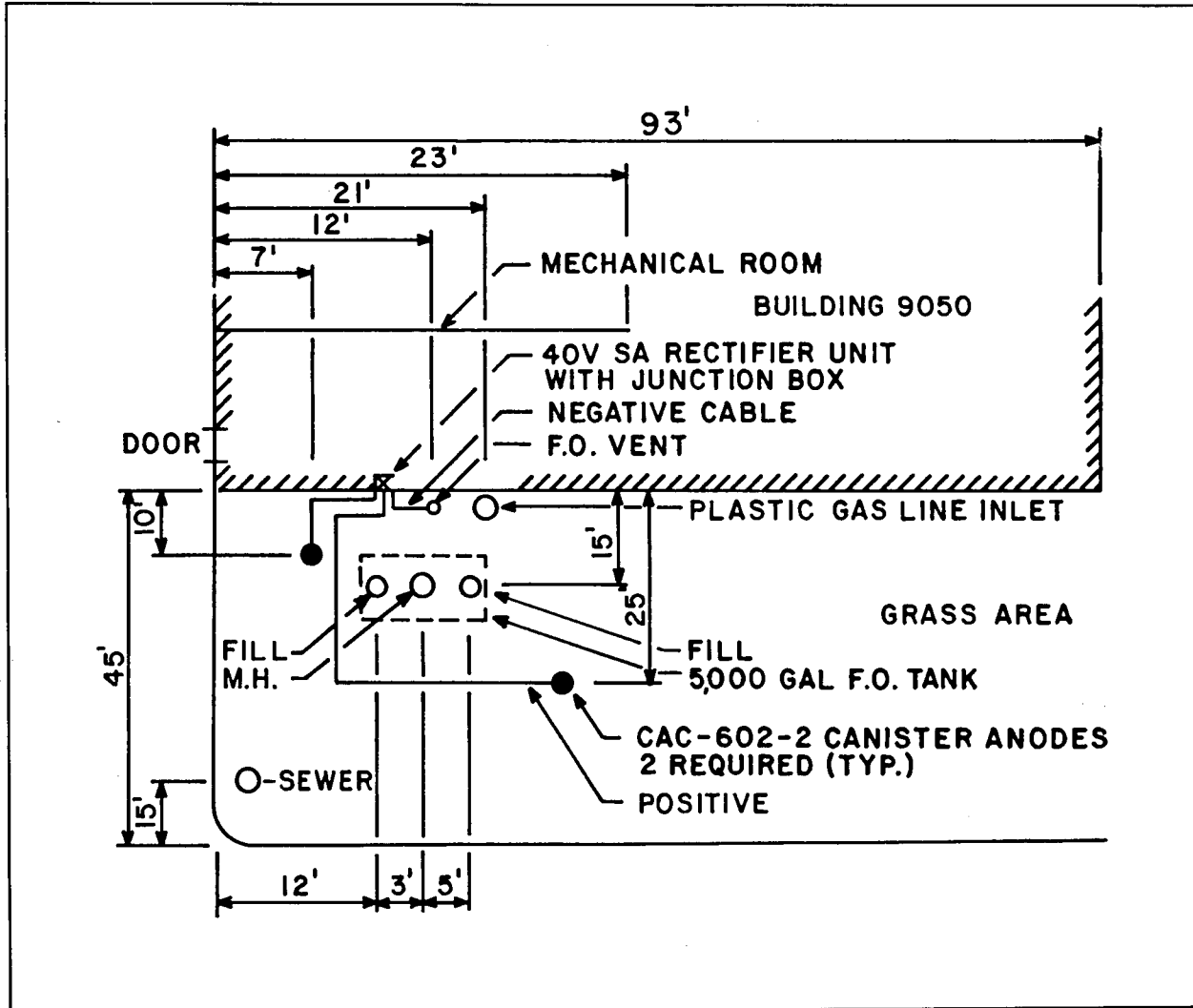

Figure 27. Layout of installed cathodic protection system.

Table 14. Structure-to-electrolyte potentials.

Without Interrupter:									
Location	Oscilloscope		Cathodic Protection Analyzer			Waveform Analyzer		DVM	
	max	min	max	avg	min	on	off	on	
1	1.240	1.065	1.239	1.168	1.068	1.165	1.031	1.167	
2	3.100	1.350	3.015	2.270	1.339	2.276	1.313	2.266	
3	1.410	1.050	1.403	1.247	1.055	1.244	0.964	1.245	
4	2.800	1.440	2.752	2.152	1.454	2.129	1.299	2.172	
Note: Waveform Analyzer (WFA) used with pulse generator.									
With Interrupter:									
Location	DVM								
	on	off							
1	1.080	0.935							
2	2.212	1.150							
3	1.204	0.894							
4	2.092	1.160							
Tank-to-Soil Measurement Locations:									
			4						
	Tank		<div style="border: 1px solid black; width: 200px; height: 60px; margin: 0 auto; display: flex; justify-content: space-around; align-items: center;"> * 1 MH *2 </div>						* = fill MH = manhole
			3						
	Building		<div style="border: 1px solid black; width: 150px; height: 30px; margin: 0 auto; display: flex; justify-content: space-between; align-items: center;"> Rectifier </div>						
<u>Rectifier Data:</u> DC Volts 18.0V DC Amps 0.6A									

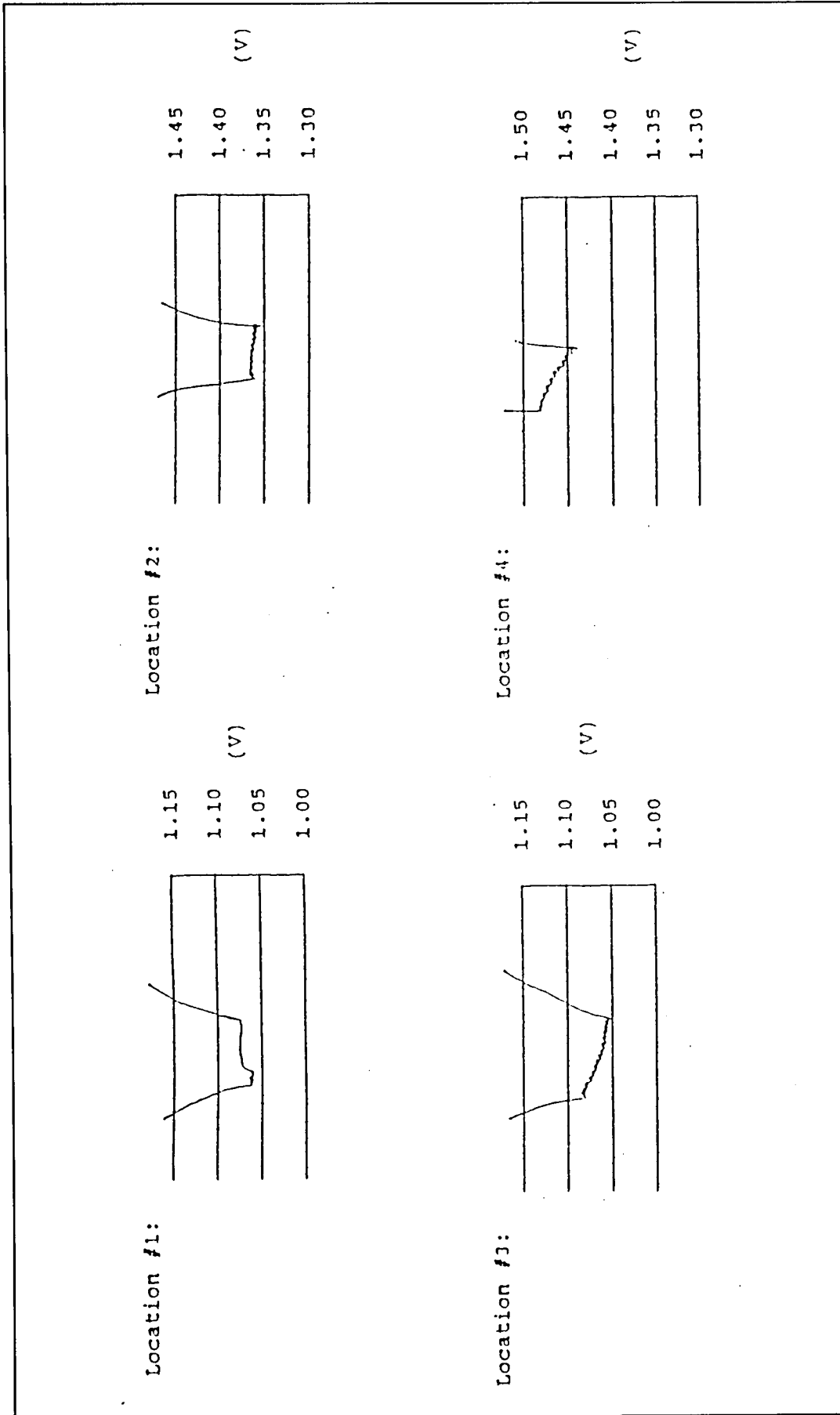

Figure 28. Amplified oscilloscope trace CP waveform for UST at Fort Lee, VA.

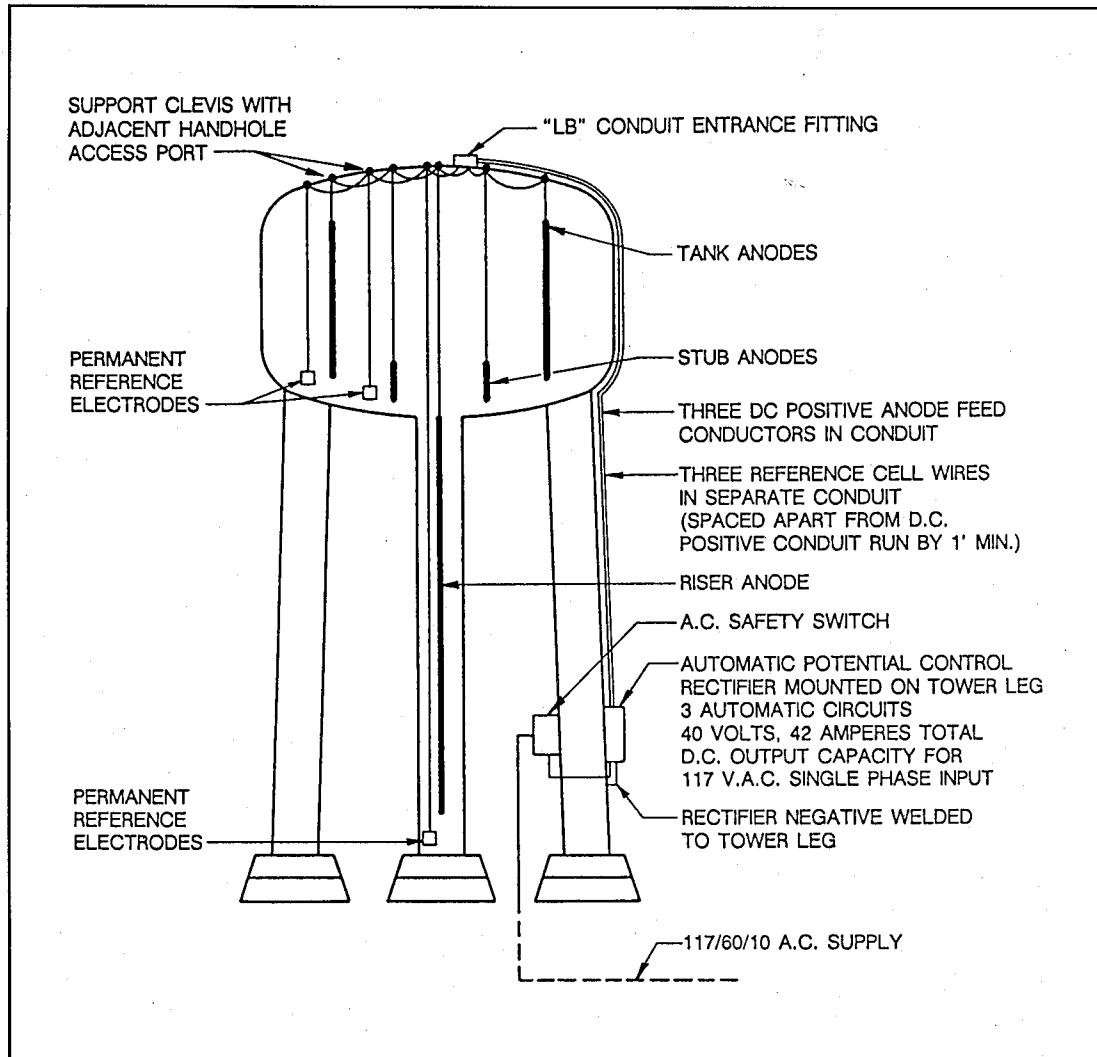

Figure 29. Typical elevated water tank showing ceramic-coated rod anode arrangement.

Table 15. Pipe-to-soil potential measurements, 6-in. pipeline.

(All Readings in Volts)										
MILE	WFA-1		POLYCODER		CPA-730			CPA/SP1		FLUKE 75
	on	off	on	off	max	avg	min	high	norm	on
319.6	-1.143	-0.845	-1.148	-0.806	-1.507	-1.166	-0.773	-0.966	-1.014	-1.143
320.3	-0.872	-0.800	-0.874	-0.790	-0.906	-0.887	-0.871	-0.863	-0.853	-0.872
320.8	-0.856	-0.711	-0.859	-0.691	-0.895	-0.873	-0.855	-0.837	-0.837	-0.856
321.0	-1.133	-1.049	-1.140	-1.043	-1.158	-1.143	-1.126	-0.966	-1.014	-1.135
321.2	-0.801	-0.729	-0.804	-0.727	-0.824	-0.816	-0.809	-0.795	-0.792	-0.801
321.9	-0.483	-0.475	-0.486	-0.475	-0.498	-0.495	-0.492	-0.581	-0.575	-0.483
322.4	-0.552	-0.546	-0.554	-0.554	-0.566	-0.562	-0.558	-0.544	-0.542	-0.551
322.8	-0.559	-0.553	-0.562	-0.562	-0.567	-0.564	-0.561	-0.544	-0.541	-0.559
323.3	-0.635	-0.604	-0.638	-0.609	-0.658	-0.645	-0.634	-0.664	-0.655	-0.635
323.35	-0.572	-0.558	-0.575	-0.575	-0.596	-0.587	-0.579	-0.555	-0.551	-0.572
323.7	-0.668	-0.656	-0.670	-0.670	-0.676	-0.671	-0.667	-0.645	-0.645	-0.668
324.3	-0.461	-0.461	-0.465	-0.465	-0.471	-0.462	-0.452	-0.400	-0.459	-0.461
324.8	-0.561	-0.556	-0.565	-0.565	-0.579	-0.565	-0.549	-0.540	-0.540	-0.561
325.0	-0.567	-0.553	-0.567	-0.567	-0.605	-0.574	-0.534	-0.552	-0.554	-0.567

Table 16. Pipe-to-soil potential measurements, 8-in. pipeline.

(All Readings in Volts)										
MILE	WFA-1		POLYCODER		CPA-730			CPA/SP1		FLUKE
	on	off	on	off	max	avg	min	high	norm	on
319.6	-1.112	-0.927	-1.119	-0.909	-1.329	-1.127	-0.891	-0.948	-0.980	-1.109
320.3	-0.824	-0.759	-0.827	-0.751	-0.867	-0.844	-0.821	-0.831	-0.827	-0.824
320.8	-0.822	-0.705	-0.826	-0.693	-0.863	-0.843	-0.824	-0.827	-0.822	-0.822
321.0	-1.121	-1.029	-1.124	-1.022	-1.147	-1.131	-1.115	-0.966	-1.014	-1.121
321.2	-0.795	-0.725	-0.798	-0.720	-0.821	-0.812	-0.804	-0.789	-0.787	-0.796
321.9	-0.542	-0.504	-0.544	-0.507	-0.555	-0.551	-0.548	-0.660	-0.638	-0.541
322.4	-0.546	-0.521	-0.549	-0.525	-0.560	-0.556	-0.553	-0.660	-0.640	-0.545
322.7	-0.648	-0.605	-0.651	-0.609	-0.672	-0.666	-0.661	-0.640	-0.639	-0.649
322.8	-0.579	-0.565	-0.580	-0.580	-0.592	-0.589	-0.585	-0.610	-0.605	-0.579
323.3	-0.641	-0.595	-0.643	-0.601	-0.670	-0.655	-0.643	-0.680	-0.674	-0.641
323.7	-0.694	-0.662	-0.696	-0.667	-0.707	-0.703	-0.699	-0.699	-0.690	-0.695
324.3	-0.423	-0.417	-0.425	-0.425	-0.437	-0.429	-0.420	-0.451	-0.451	-0.423
324.8	-0.486	-0.482	-0.488	-0.488	-0.499	-0.490	-0.479	-0.470	-0.469	-0.485
325.0	-0.599	-0.578	-0.599	-0.599	-0.651	-0.603	-0.541	-0.580	-0.577	-0.597

Table 17. Pipe-to-soil potential measurements, 12-in. pipeline.

(All Readings in Volts)										
MILE	WFA-1		POLYCODER		CPA-730			CPA/SP1		FLUKE
	on	off	on	off	max	avg	min	high	norm	on
319.6	-1.416	-0.911	-1.421	-0.853	-1.993	-1.436	-0.785	-1.014	-1.085	-1.418
319.7	-1.162	-0.900	-1.166	-0.867	-1.484	-1.179	-0.807	-0.965	-1.015	-1.163
320.0	-1.680	-1.050	-1.686	-0.937	-2.377	-1.705	-0.998	-1.075	-1.164	-1.680
320.3	-1.260	-0.940	-1.268	-0.861	-1.813	-1.286	-0.723	-0.996	-1.062	-1.266
320.8	-1.300	-0.810	-1.295	-0.783	-1.861	-1.311	-0.772	-1.105	-1.074	-1.292
321.1	-1.370	-0.990	-1.381	-0.932	-1.888	-1.392	-0.921	-1.020	-1.095	-1.376
321.18	-1.370	-0.900	-1.376	-0.856	-1.911	-1.460	-1.020	-1.037	-1.110	-1.370
321.19	-1.350	-0.920	-1.352	-0.856	-1.839	-1.372	-0.925	-1.015	-1.091	-1.351
321.2	-1.330	-0.940	-1.331	-0.893	-1.346	-0.892	-0.827	-1.024	-1.101	-1.326
321.9	-1.090	-0.740	-1.092	-0.722	-1.535	-1.109	-0.680	-0.960	-1.005	-1.092
322.4	-1.130	-0.820	-1.134	-0.793	-1.556	-1.150	-0.749	-0.980	-1.031	-1.132
322.8	-1.128	-0.833	-1.134	-0.830	-1.522	-1.142	-0.774	-0.970	-1.017	-1.130
323.3	-1.165	-0.884	-1.169	-0.880	-1.497	-1.185	-0.874	-0.985	-1.046	-1.166
323.7	-1.115	-0.899	-1.116	-0.893	-1.417	-1.130	-0.863	-0.964	-1.016	-1.116
324.3	-0.811	-0.680	-0.817	-0.683	-1.059	-0.816	-0.601	-0.764	-0.784	-0.811
324.8	-0.716	-0.662	-0.720	-0.664	-0.834	-0.724	-0.601	-0.696	-0.699	-0.716
325.0	-0.693	-0.653	-0.699	-0.659	-0.768	-0.703	-0.620	-0.675	-0.674	-0.693

7 Conclusions

Commercially available instant off-potential measurement devices were evaluated both in a laboratory and field environment. The ability of off-potential instrumentation to measure the true instant off-potential of a structure was determined for three different types of cathodically protected structures. The types of structures evaluated were an underground fuel storage tank, elevated steel water storage tank, and underground gas distribution system. The types of instant off-potential measurement systems evaluated were as follows:

1. A Xetron Cathodic Protection Analyzer (CPA) Model 730
2. A M.C. Miller Waveform Analyzer Model WFA-1
3. A digital voltmeter (DVM) and current interrupter
4. A portable oscilloscope.

Each system provided slightly different CP system performance monitoring based on "Instant Off-Potential" (IOP) criteria for elevated water storage tanks, underground storage tanks, and an underground gas distribution system according to the revised NACE RP0169-92 Criteria.

The following conclusions can be drawn for each type of instant off-potential measurement system utilized for evaluation of a CP system installed on USTs, elevated water storage tanks, and on underground gas distribution systems.

Underground Fuel Storage Tank

The minimum measurements, which represent the IOP, obtained by the Xetron Cathodic Protection Analyzer (CPA) Model 730 varied by less than 1 percent from the minimum oscilloscope readings both in the laboratory and in the field. This indicates that the CPA reads the same point as observed by the oscilloscope on the polarization decay curve.

For the M.C. Miller Waveform Analyzer Model WFA-1, the difference between the IOP and the oscilloscope IOP varied between 34 and 141 millivolts in the field measurements. From these measurements, it can be inferred that the WFA-1 is measuring a

point lower down on the polarization decay curve than the oscilloscope. However, for this particular cathodically protected structure, the difference is not significant.

The worst case, or lowest point on the decay curve, was obtained by measuring the off-potential using a digital voltmeter (DVM) and current interrupter, and by taking the second updated reading as the IOP. Field measurements showed a difference between the two readings of 130 to 280 millivolts. Although the interrupted off-potential values satisfied both NACE RP0169-92 criteria, it may be possible for coating to be damaged while using this method since the true IOP may be more negative than the readings indicate.

Elevated Steel Water Storage Tanks

The instant off-potential measurements (IOP) obtained by the Xetron Cathodic Protection Analyzer (CPA Model 703) varied from -0.853V to 0.920V for the top section, -0.848V to -0.914V for the middle section and -0.83V to -0.91V for the bottom section of the tank. The IOP readings indicated complete cathodic protection was being provided to the wetted surface of the tank. The IOP data also demonstrated that some of the areas on the tank surface may be polarized slightly greater than the -0.85V IOP NACE criteria require. However, there was no danger of exceeding the hydrogen over voltage of -1.2V and causing cathodic disbondment of the coating system.

Underground Gas Distribution Systems

The effectiveness of using IOP measurement devices on underground utility distribution systems depends on several factors such as size of system (e.g., pipe diameter and length), proximity of foreign structures that are also cathodically protected, and electrical isolation. The current level of IOP technology works well on discreet, well isolated pipe sections but does not have the capability of waveform discrimination on long line pipelines. The long line pipelines have spikes induced along the length of the pipeline. These inductive spikes occur from rectifier overlap and interference from other close proximity cathodically protected structures. In general, the Wave Form Analyzer (WFA-1), Polycorder, and Cathodic Protection Analyzer (CPA 730) readings were within 50 mV of each other.

8 Recommendations

It is recommended that instant off-potential measurement devices such as the Cathodic Protection Analyzer, Wave Form Analyzer, and Polycorders be considered as alternative systems to evaluate the effectiveness of a cathodically protected steel structure such as underground fuel storage tanks, elevated steel water storage tanks, and underground gas distribution systems. The IOP measurements taken must be in accordance with NACE RP0169 criteria.

The effectiveness of IOP measurement devices for underground utility distribution systems will depend on the electrical isolation of that system and the proximity of the cathodically protected foreign structures.

References

- Corrpro Corp., *Ft. Lee, Virginia Corrosion Evaluation Survey Preliminary Report* (U.S. Army Engineering and Housing Support Center [USAEHSC], Fort Belvoir, VA, October 1989).
- Engineering Technical Letter (ETL) 1110-9-10(FR), *Impressed Current Cathodic Protection Systems Using Ceramic Anodes* (Headquarters, U.S. Army Corps of Engineers [HQUSACE], January 1991).
- Evans, Antonio, and Ivan Leef, *Water Storage Tank and Airfield Fuel Systems Cathodic Protection Evaluations: Fort Hood, Texas* (USAEHSC, September 1989).
- Hock, Vincent F., and Lewis F. Setliff, "Off-Potential Measuring Devices for Underground Steel Storage Tanks," Paper No. 478, *Corrosion 92* (Memphis, TN, 1992a).
- Hock, V.F., L.F. Setliff, R.H. Knoll, and M. McLeod, "Evaluation of Cathodic Protection Systems Using Off-Potential Measuring Devices," USACE Electrical Mechanical Engineering Conference, Dallas, TX (14-17 July 1992b).
- Hock, V.F., and M. McLeod, *User Guide and Specifications for Water Tanks and Underground Pipes and Storage Tanks*, FEAP-UG-M-92/08 (USAEHSC, January 1992).
- Kroon, David H., "Waveform Analyzer/Pulse Generator Technology Improves Close Interval Potential Surveys," *Materials Performance*, Vol 29, no. 11 (November 1990), pp 18-21.
- Kumar, A., Vincent F. Hock, Flynn Bashford, and Richard Ruzga, "Evaluation of Cathodic Protection Systems Using Ceramic Coated Anodes," Paper No. 231, *Corrosion 91* (Cincinnati, OH).
- Kumar, A., V. Hock, and M. McLeod, *User Guide and Specification for Ceramic Coated Anode Systems for Water Tanks and Underground Pipes and Storage Tanks*, FEAP-UG-M-92/08 (USAEHSC, January 1992).
- Myers, J.R., *Fundamentals and Forms of Corrosion* (Air Force Institute of Technology, 1974)
- "Real-Time Cathodic Protection Analysis," *Pipeline and Gas Journal* (February 1990).
- Recommended Practice (RP) 0169, "Control of External Corrosion on Underground or Submerged Metallic Piping Systems" (National Association of Corrosion Engineers [NACE], rev. 1992).
- RP0285, "Control of External Corrosion on Metallic Buried, Partially Buried, or Submerged Liquid Storage Systems" (NACE, rev. 1992).
- Watts, James, "Enhancing Cathodic Protection," *Pipeline and Gas Journal* (September 1989).
- Xetron Corporation, *CPA Model 730 Operator's Applications Manual* (Cincinnati, OH, 1990).

Appendix A: Laboratory Data

Table A1. Water sample chemistry data.

Samples Taken Before Testing				
	Tank 1	Tank 2	Tank 3	Tank 4
pH**	8.40	8.60	8.60	8.50
Zn	0.1	0.1	0.1	0.1
Fe	BDL*	BDL	BDL	BDL
Cu	BDL	BDL	BDL	BDL
Ca	11.6	14.1	15.0	15.0
Mg	9.9	10.1	10.2	10.4
Alkalinity (as CaCO ₃)	91.4	90.1	92.3	82.4
Hardness (as CaCO ₃)	77.5	77.5	78.8	80.0
Dissolved O ₂ **	10	8	12	9
Total Dissolved Solids	100	110	130	145
Ammonia (NH ₄)	BDL	BDL	BDL	BDL
Samples Taken After Testing				
	Tank 1	Tank 2	Tank 3	Tank 4
pH**	8.35	8.35	8.39	8.44
Zn	BDL*	BDL	BDL	0.2
Fe	0.1	0.2	0.1	0.1
Cu	0.1	BDL	BDL	0.3
Ca	9.9	10.6	12.9	11.1
Mg	11.9	12.7	12.2	11.3
Alkalinity (as CaCO ₃)	98.3	98.5	93.4	93.4
Hardness (as CaCO ₃)	90.1	82.5	77.5	77.5
Dissolved O ₂ **	6.6	6.2	6.6	6.4
Total Dissolved Solids	150	130	130	110
Ammonia (NH ₄)	BDL	BDL	BDL	BDL
*BDL-Below detection levels				
**Dissolved O ₂ measured by electrode rather than test kits. Results are usually higher with the colorimetric test kit than electrode.				

Table A2. Laboratory structure-to-electrolyte potential (Tank 1).

Date/Time	Oscilloscope		Cathodic Protection Analyzer (CPA)					Waveform Analyzer (WFA)		Fluke (DMM)	Output Voltage	Tap
	Max	Min	Max	Avg	Min	SP1	On	Off				
6/8/92 4:06 pm	-1.064	-0.874	-1.071	-0.988	-0.873				On	-0.987		
6/9/92 9:00 am	-1.114	-0.926	-1.114	-1.033	-0.921			-1.029	-0.921	-1.030		
6/9/92 1:00 pm	-1.128	-0.862	-1.130	-0.986	-0.863			-0.982	0.862	-0.985	3.066	A3
6/9/92 1:30 pm	-1.144	-0.880	-1.150	-1.005	-0.880			-1.002	-0.885	-1.004	3.101	A3
6/9/92 2:11 pm	-1.146	-0.890	-1.151	-1.010	-0.889			-1.001	-0.885	-1.008	3.066	A3
6/9/92 3:06 pm	-0.954	-0.854	-0.959	-0.894	-0.856			-0.893	-0.857	-0.892	2.190	A2
6/9/92 3:56 pm	-0.950	-0.858	-0.954	-0.891	-0.854			-0.891	-0.856	-0.890	2.186	A2
6/10/92 9:15 am	-0.924	-0.828	-0.937	-0.870	-0.830			-0.868	-0.834	-0.869	2.147	A2
6/10/92 11:34 am	-1.140	-0.882	-1.147	-1.004	-0.879			-0.999	-0.880	-0.994	3.094	A3
6/10/92 2:10 pm	-1.150	-0.880	-1.156	-1.010	-0.888			-1.006	-0.890	-1.009	3.105	A3
6/10/92 3:15 pm	-1.148	-0.888	-1.157	-1.012	-0.888			-1.006	-0.887	-1.010	3.103	A3
6/10/92 4:00 pm	-1.156	-0.886	-1.158	-1.013	-0.888			-1.009	-0.889	-1.011	3.116	A3
6/11/92 8:12 am	-1.096	-0.824	-1.106	-0.959	-0.834			-0.949	-0.832	-0.956	3.070	A3
6/11/92 8:14 am	-1.092	-0.824	-1.100	-0.951	-0.827			-0.950	-0.832	-0.948	3.094	A3
6/12/92 9:36 am	-1.342	-0.994	-1.340	-1.182	-0.991			-1.167	-0.982	-1.178	7.550	B2
6/12/92 10:57 am	-0.978	-0.884	-0.973	-0.924	-0.880			-0.918	-0.877	-0.921	3.111	A3
6/15/92 10:55 am	-0.876	-0.782	-0.886	-0.837	-0.794			-0.825	-0.783	-0.836	3.051	A3
6/15/92 3:40 pm	-1.048	-0.856	-1.062	-0.972	-0.868			-0.968	-0.871	-0.967	3.052	A3
6/16/92 9:00 am	-1.150	-0.968	-1.148	-1.060	-0.960			-1.048	-0.950	-1.052	5.20	A5
6/16/92 9:56 am	-0.960	-0.880	-0.957	-0.914	-0.877			-0.912	-0.881	-0.914	3.095	A3
6/16/92 12:27 pm	-0.938	-0.866	-0.936	-0.887	-0.860			-0.895	-0.867	-0.894	3.067	A3
6/16/92 1:30 pm	-0.932	-0.852	-0.933	-0.890	-0.856			-0.882	-0.851	-0.881	3.043	A3
6/16/92 3:09 pm	-0.934	-0.848	-0.927	-0.884	-0.846			-0.882	-0.850	-0.882	3.053	A3
6/17/92 10:04 am	-0.942	-0.854	-0.931	-0.889	-0.852			-0.887	-0.851	-0.888	3.070	A3
6/17/92 2:17 pm	-0.928	-0.846	-0.930	-0.888	-0.850			-0.889	-0.849	-0.886	3.053	A3
6/17/92 4:19 pm	-0.936	-0.848	-0.932	-0.876	-0.847			-0.884	-0.846	-0.886	3.070	A3
6/19/92 10:45 am	-0.828	-0.738	-0.825	-0.780	-0.739			-0.776	-0.738	-0.779	3.025	A3
6/22/92 9:48 am	-0.844	-0.762	-0.844	-0.799	-0.760			-0.798	-0.762	-0.800	3.066	A3
6/23/92 11:40 am	-0.912	-0.826	-0.915	-0.869	-0.826			-0.866	-0.829	-0.867	3.130	A3
6/24/92 9:42 am	-0.930	-0.854	-0.932	-0.886	-0.847			-0.882	-0.847	-0.885	3.371	A3
6/24/92 2:00 pm	-0.948	-0.868	-0.950	-0.904	-0.868			-0.899	-0.866	-0.896	3.077	A3

Appendix B: Fort Hood Field Data

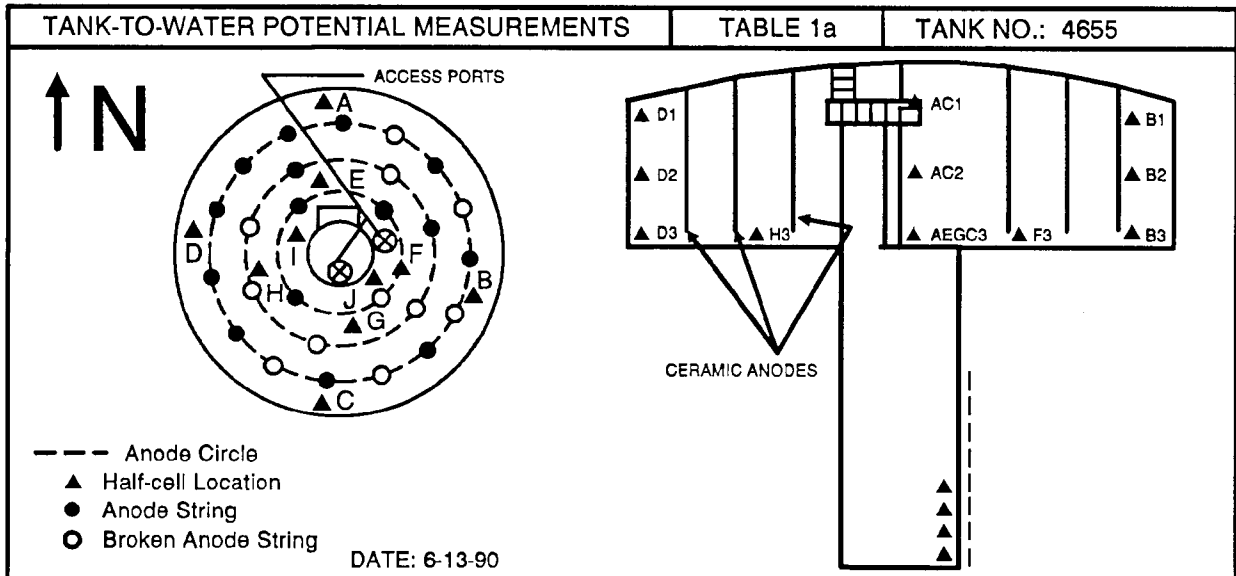

BOWL	PHYSICAL LOCATION	Potential Readings (-Volts)		
		No. 1 (top)	No. 2 (middle)	No. 3 (bottom)
A	NORTH WALL	1.15	1.15	1.10
B	EAST WALL	1.15	1.15	1.10
C	SOUTH WALL	1.15	1.15	1.10
D	WEST WALL	1.15	1.10	1.10
E	DIAGONAL			1.10
F	DIAGONAL			1.10
G	DIAGONAL			1.05
H	DIAGONAL			1.10
I	INNER WALL	1.15	1.10	1.10
J	INNER WALL	1.15	1.10	1.10

RISER	PHYSICAL LOCATION	AT DEP
I 1	TOP OF RISER	
I 2	NONE	
I 3		
I 4		
I 5		
I 6		
I 7		
I 8		
I 9		
I 10		
I 11		
I 12		

REMARKS:
 Interior & exterior still in very good condition. 1st readings in 4655 were too high at 1.65. Tank was polarized at 1.10. Removed rectifier & installed rectifier with smaller output. Reading 1.10 to 1.15 tank still polarized at .95.

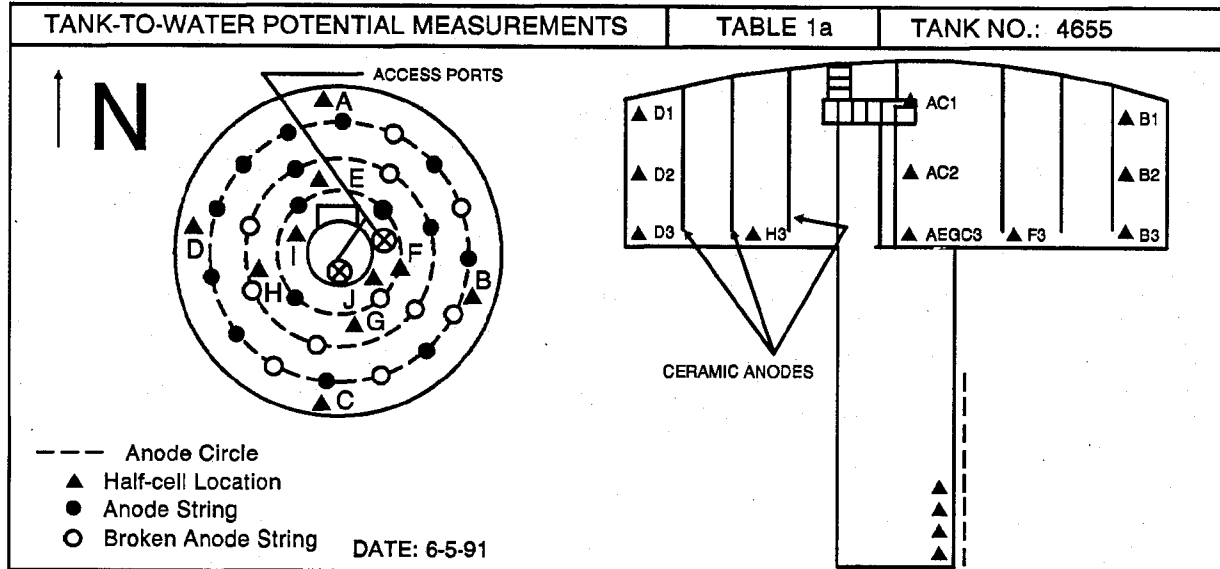

BOWL	PHYSICAL LOCATION	Potential Readings (-Volts)					
		No. 1 (top)		No. 2 (middle)		No. 3 (bottom)	
		ON	OFF	ON	OFF	ON	OFF
A	NORTH WALL	.85	.75	.86	.75	.88	.75
B	EAST WALL	.85	.74	.85	.73	.85	.75
C	SOUTH WALL	.85	.72	.85	.74	.86	.75
D	WEST WALL	.85	.75	.86	.75	.86	.73
E	DIAGONAL					.86	.73
F	DIAGONAL					.86	.75
G	DIAGONAL					.88	.75
H	DIAGONAL					.86	.75
I	INNER WALL	.86	.74	.88	.75	.86	.74
J	INNER WALL	.86	.74	.88	.76	.86	.74

RISER	PHYSICAL LOCATION	AT DEP
I 1	TOP OF RISER	
I 2	NONE	
I 3		
I 4		
I 5		
I 6		
I 7		
I 8		
I 9		
I 10		
I 11		
I 12		

REMARKS:

Interior & exterior still in very good condition.

TANK-TO-WATER POTENTIAL MEASUREMENTS		TABLE 1a	TANK NO.: 4655				
DATE: 7-30-92							
BOWL	PHYSICAL LOCATION	Potential Readings (-Volts)					
		TOP AVE	MIN	MIDDLE AVE	MIN	BOTTOM AVE	MIN
A	NORTH WALL	.998	.866	1.011	.881	.920	.83
B	EAST WALL	.944	.853	.948	.848	.943	.84
C	SOUTH WALL	1.037	.920	1.042	.914	1.048	.90
D	WEST WALL	1.013	.904	1.000	.892	1.044	.88
E	DIAGONAL					1.055	.90
F	DIAGONAL					1.041	.90
G	DIAGONAL					1.038	.90
H	DIAGONAL					1.064	.91
I	INNER WALL	1.052	.914	1.062	.910	1.031	.89
J	INNER WALL	1.049	.910	1.042	.903	1.021	.89
RISER	PHYSICAL LOCATION	AT DEP					
I 1	TOP OF RISER						
I 2	NONE						
I 3							
I 4							
I 5							
I 6							
I 7							
I 8							
I 9							
I 10							
I 11							
I 12							
REMARKS:							

Appendix C: Criteria for a Low-Maintenance CP System

Specific provisions will guarantee a low-maintenance CP system with minimal operation and maintenance costs. The first provision is to use the corrosion control acceptance criteria checklist (FEAP UG-92-08) for the Corps of Engineers (COE) or DEH/DPW inspectors. There is one guide/checklist for each of the three commonly installed CP systems: (1) sacrificial anode systems, (2) impressed current underground applications, and (3) impressed current water tank applications. This checklist will help the COE and DEH guarantee that the CP system installed is the one called for in the specifications and/or engineering drawings. Provisions are described below.

There are a number of traits of low-maintenance, impressed-current CP systems common to each type of CP application. The first of these would be well-made splices in the connections from the rectifier to the anode or cathode. If an anode bed is placed less than 600 ft. away from the rectifier, it will be less costly and more reliable to run separate leads from the rectifier to each anode than to run header cable to the anode bed and then splice off the header cable to the anodes. Any splice in a wire should be a cause for concern; a low-maintenance CP system should minimize the number of splices needed. If there must be splices in an underground CP system, they should be made above ground in a moisture proof, easily accessible area to provide for easy inspection and replacement if there is a splice failure.

Another common trait is that a low-maintenance CP system must be checked regularly to ensure proper operation. A monthly rectifier check should include a check of the output voltage or current to ensure that the measured values are within the specified levels for protection of the structure. A simple, inexpensive way to monitor a rectifier with a quick eye-check is to purchase the rectifier with red and green lights already installed. The green light should turn on when the rectifier has AC power to it and the rectifier is providing the specified output. The red light should shine when there is AC power to the rectifier, but the rectifier is not producing the specified output. Neither light should work when there is no AC power to the rectifier. These lights should be visible from a distance, in the daylight. DEH personnel can then note whether or not a rectifier is operating correctly or incorrectly with a simple eye-check while driving by. This will provide for easy weekly monitoring that can help avoid corrosion failure and subsequent repair/replacement of the structure being protected.

The anodes used for the CP system cannot be expected to exceed their design current output. Anodes should be called for in the engineering drawings that will provide a life of 25 years (Reference ETL 1110-9-10 [FR] and TM 5-811-7). The anodes must also be obtained from a responsible anode supplier that will stand behind their product. A poorly manufactured anode can cause early failure of a CP system, and it certainly provides for a high-maintenance CP system.

The last provision for a low-maintenance CP system is to include the proper rectifier for the specific application. There are two types of rectifiers that will provide for a low-maintenance CP system. For any underground CP applications, an adjustable constant current output rectifier needs to be used. As discussed in the **Power Sources** (Chapter 3), this will ensure that the structure sees the required protective current through a generous range of electrolyte resistivities. For all submerged or moving water CP applications, an automatic potential controlled rectifier should be used. Again, as discussed in the **Power Sources** section, this will keep the structure protected through a dynamically changing electrolyte. With either rectifier, there needs to be quality assurance from the rectifier manufacturer. A rectifier should not be purchased for a low-maintenance CP system unless the rectifier manufacturer will provide a 1-year on-site warranty. This warranty should include repair and replacement costs if there are defects in the materials and workmanship, or if there are operation defects.

USACERL DISTRIBUTION

Chief of Engineers
ATTN: CEHEC-IM-LH (2)
ATTN: CEHEC-IM-LP (2)
ATTN: CEMP-ET
ATTN: CERD-L

CECPW 22310-3862
ATTN: CECPW-ES

US Army Engr District
ATTN: Library (40)

US Army Engr Division
ATTN: Library (12)

US Army Europe
21st Support Command
ATTN: DPW (10)
US Army Berlin
ATTN: AEBA-EH 09235
ATTN: AEBA-EN 09235

INSCOM
ATTN: IAV-DPW 22186

HQ XVIII Airborne Corps 28307
ATTN: AFZA-DPW-EE

US Army Materiel Command (AMC)
Alexandria, VA 22333-0001
ATTN: AMCEN-F
Installations: (19)

FORSCOM
Forts Gillem & McPherson 30330
ATTN: FCEN
Installations: (23)

TRADOC
Fort Monroe 23651
ATTN: ATBO-G
Installations: (20)

Fort Belvoir 22060
ATTN: CECC-R 20314-1000
ATTN: Engr Strategic Studies Ctr

USARPAC 96858
ATTN: DPW

CEWES 39180
ATTN: Library

CECRL 03755
ATTN: Library

Military Dist of WASH
Fort McNair
ATTN: ANEN 20319

USA Engr Activity, Capital Area
ATTN: Library 22211

Engr Societies Library
ATTN: Acquisitions 10017

Defense Logistics Agency
ATTN: DLA-WI 22304

USA Japan (USARJ)
ATTN: APAJ-EN-ES 96343

US Army Envr Hygiene Agency
ATTN: HSHB-ME 21010

US Gov't Printing Office 20401
ATTN: Rec Sec/Deposit Sec (2)

Defense Tech Info Center 22304
ATTN: DTIC-FAB (2)

153
9/94