

Visual Guidance Requirements for Global Positioning System Approaches

Eric Katz

DTIC
ELECTE
FEB 17 1995
S G D

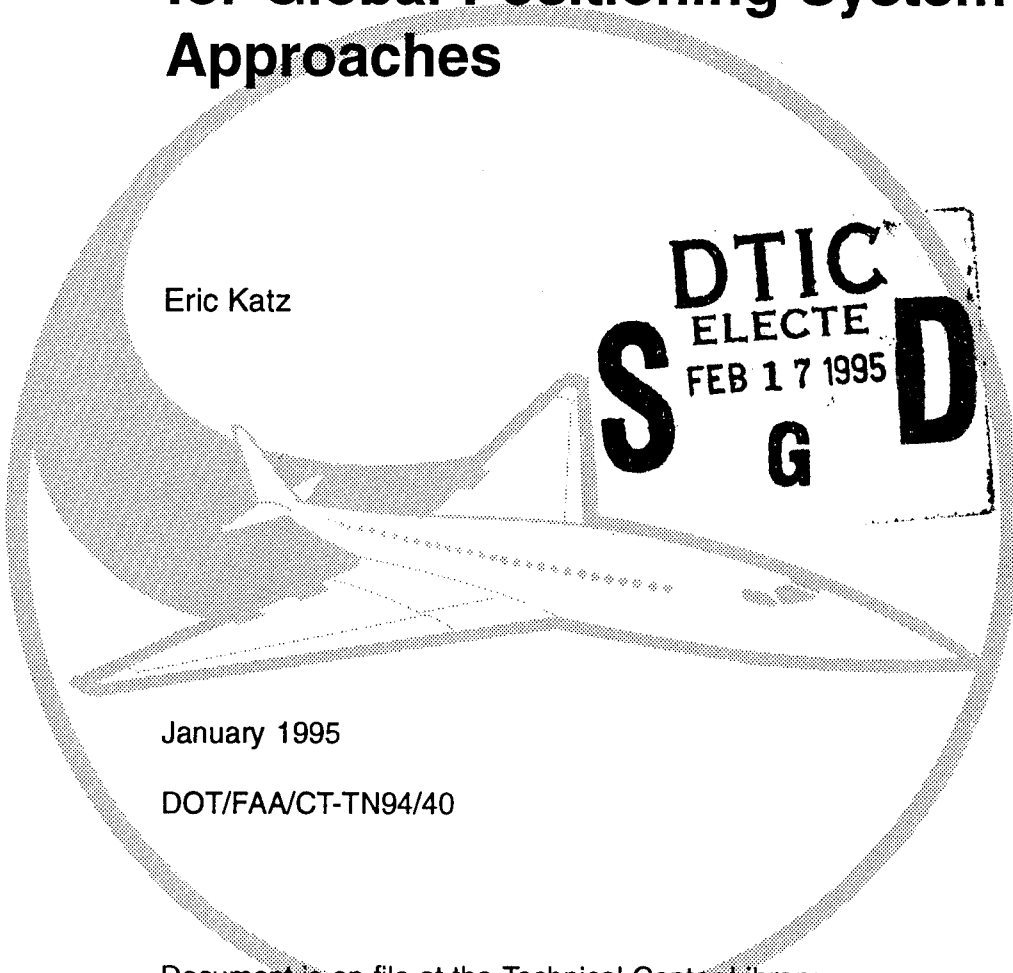

January 1995

DOT/FAA/CT-TN94/40

Document is on file at the Technical Center Library,
Atlantic City International Airport, NJ 08405.



U.S. Department of Transportation
Federal Aviation Administration
Technical Center
Atlantic City Airport, NJ 08405

19950209 042

DISTRIBUTION STATEMENT A

Approved for public release;
Distribution Unlimited

ate technical note techn

NOTICE

This document is disseminated under the sponsorship of the U. S. Department of Transportation in the interest of information exchange. The United States Government assumes no liability for the contents or use thereof.

The United States Government does not endorse products or manufacturers. Trade or manufacturers' names appear herein solely because they are considered essential to the objective of this report.

1. Report No. DOT/FAA/CT-TN94/40		2. Government Accession No.		3. Recipient's Catalog No.	
4. Title and Subtitle Visual Guidance Requirements for Global Positioning System Approaches				5. Report Date January 1995	
				6. Performing Organization Code ACD-110	
7. Author(s) Eric S. Katz				8. Performing Organization Report No. DOT/FAA/CT-TN94/40	
9. Performing Organization Name and Address Federal Aviation Administration Technical Center Atlantic City International Airport, NJ 08405				10. Work Unit No. (TRAIS)	
				11. Contract or Grant No.	
12. Sponsoring Agency Name and Address U. S. Department of Transportation Federal Aviation Administration Technical Center Atlantic City International Airport, NJ 08405				13. Type of Report and Period Covered Technical Report	
				14. Sponsoring Agency Code	
15. Supplementary Notes					
16. Abstract This technical note presents a discussion of visual guidance requirements for supporting aircraft instrument approach and landing operations, as they are presently perceived, and addresses further the issue of future requirements in support of Global Positioning System (GPS) instrument approaches. Current instrument approach procedures and the various visual guidance systems required to support them are discussed along with a brief dissertation concerning the purpose of visual guidance system components. The GPS visual guidance requirements are analyzed in detail, and recommendations for supporting visual aids are provided.					
17. Key Words Visual Approach Guidance Global Positioning System Instrument Procedures			18. Distribution Statement Document is on file at the Technical Center Library, Atlantic City International Airport, New Jersey 08405		
19. Security Classif. (of this report) Unclassified		20. Security Classif. (of this page) Unclassified		21. No. of Pages 20	22. Price

TABLE OF CONTENTS

	Page
EXECUTIVE SUMMARY.....	v
BACKGROUND.....	1
DISCUSSION.....	2
Current Minima/Lighting Requirements.....	2
Numbers of New Category I Procedures.....	2
Cost Factors.....	2
Purpose of Visual Guidance Systems.....	3
Lighting System Credits.....	7
Analysis of Current Minima.....	9
The Issues.....	11
RECOMMENDATIONS.....	15

LIST OF ILLUSTRATIONS

Figure	Page
1 MALSR Approach Lighting System.....	4
2 ALSF-1 Approach Lighting System.....	5
3 ALSF-2 Approach Lighting System.....	6
4 One-Half-Mile Visual Segment.....	8
5 Three-Quarter-Mile Visual Segment.....	8
6 System/Minima Chart.....	10
7 Modified ALSF-2 System.....	14

EXECUTIVE SUMMARY

Ground-based approach guidance systems such as Instrument Landing Systems/Microwave Landing Systems permit aircraft to approach and land in extremely low visibility conditions, but only with attendant relatively expensive installation of sophisticated ground equipment at each airport. One very promising guidance concept currently under development is the Global Positioning System (GPS). Application of GPS technology, when fully implemented and available for use by pilots flying a wide range of aircraft, will permit the successful execution of low-visibility precision approaches at many airports not presently equipped for such instrument flight rule (IFR) operations because of funding or siting limitations.

This technical note presents a discussion of visual guidance requirements for supporting instrument approach and landing operations, as they are presently perceived, and addresses the issue of future requirements in support of GPS instrument approaches. Current instrument approach procedures and the associated visual guidance systems required to support them are discussed to determine their applicability to support GPS approaches. The technical note also describes the function of visual guidance system components and provides recommendations for the necessary visual systems needed to support GPS approaches.

Finally, the technical note suggests that a study to determine the feasibility of achieving greater economy in the installation, operation, and maintenance of approach lighting systems through reduction in the number of lights required should be initiated.

Accession For	
NTIS	CRA&I <input checked="" type="checkbox"/>
DTIC	TAB <input type="checkbox"/>
Unannounced	<input type="checkbox"/>
Justification _____	
By _____	
Distribution /	
Availability Codes	
Dist	Avail and/or Special
A-1	

BACKGROUND

Ground-based approach guidance systems (ILS/MLS) permit aircraft to takeoff and land in extremely low visibility conditions, but only with attendant relatively expensive installation of sophisticated ground equipment at each airport. One very promising electronic guidance concept currently under development is the Global Positioning System (GPS). Application of GPS technology, when fully implemented and available for use by pilots flying a wide range of aircraft, will permit the successful execution of precision approaches in low visibility at many airports not presently equipped for such instrument flight rule (IFR) operations because of funding or siting limitations.

In April 1994 GPS airborne avionic equipment became available for installation in even the smallest aircraft. The system currently provides horizontal guidance approach capability at approximately 4,000 runways served by conventional nav aids, e.g., very high frequency omnidirectional range (VOR) and nondirectional beacons (NDB). Work is in progress to add over 500 new approaches by the end of 1995.

By the end of 1996, the Differential GPS Wide Area Augmentation System (DGPS/WAAS) should be implemented. DGPS provides greater accuracy through correction signals sent to aircraft from a ground facility via a geostationary satellite and is expected to provide Category I (CAT I) horizontal and vertical guidance approach capabilities at nearly all airports/runways. This DGPS/WAAS, with its network of ground reference stations, will reduce the cost of installing ground facilities at each and every GPS served airport and provide precision approach capability. The lowest precision approach minimums (CAT II/III) will be attained at airports having additional local area DGPS ground facilities.

At present, there is no established requirement for approach lighting aids to support certain instrument approach and landing operations at runways other than those served by precision approach NAVAIDS. Specific approach lighting systems (ALS) and, in some cases, runway in-pavement centerline and touchdown zone lighting systems are only required to achieve the lowest approvable categories for precision approach and landing operations.

In light of this, it is obvious that the GPS instrument approach capability can be attained with only the relatively low cost of developing approach procedures for the many airports involved. No additional ground equipment (lighting, ground differential correction facility, etc.) will be needed in order to support such capabilities.

A significant portion of the cost to realize the full benefit of implementing the DGPS/WAAS for a large number of airports, particularly at those locations where the lowest approvable CAT I, II, and III operations are desired, could be for the ALS.

DISCUSSION

CURRENT MINIMA/LIGHTING REQUIREMENTS.

Precision approach and landing authorizations are established by categories. Category I is defined as the condition where visibility is not less than 1/2 statute mile or 2400-foot (and in some cases 1800-foot) Runway Visual Range (RVR) with a Decision Altitude/Height [DA(H)] of not less than 200 feet. Category II is defined as visibility of not less than 1200-foot RVR with a DA(H) of not less than 100 feet. Finally, Category III is defined as visibilities of not less than 700-, 150-, or 0-foot RVR for Category IIIA, IIIB, and IIIC respectively.

Several different visual guidance aids are required in support of these operational landing minimums. For example, lowest Category I minimums must be supported by at least medium-intensity approach lights (MALSR) and medium-intensity runway edge lights (MIRL), while Category II/III operations require high-intensity approach lighting (ALSF-1/2), high-intensity runway edge lights (HIRL), and runway centerline and touchdown lights as well as runway visual range (RVR) equipment. In summary, the lower the minimums, the more visual aids required.

NUMBERS OF NEW CATEGORY I PROCEDURES.

Currently, approximately 900 Category I, II, and III ILS/MLS civil approaches are authorized within the National Airspace System. Various projections have been made for future precision approach requirements. One projection from the NAS/MLS Demonstration Program Project 7: Future Cat II/III Requirements, estimates that 1900 runways will qualify for precision approaches by the year 2010. The April 1994 Associate Administrator for Regulation and Certification, AVR-1 DGPS/WAAS implementation plan identifies 4010 runway ends that will qualify for GPS supported approaches when the DGPS/WAAS system is completed. Regardless of the actual numbers, it is obvious that a large number of runways will have to be capable of supporting GPS precision approaches.

COST FACTORS.

Current cost estimates indicate that up to half of the implementation cost of the DGPS/WAAS system (\$370 million of \$703.5 million) may have to be attributed to support lighting system enhancements. Typical ALSF-2 installation costs are approximately \$2.8 million. MALSR costs are approximately \$0.8

million per system. Operating costs for energy and maintenance are also considered high. As a result of these large numbers, proposals are being made to develop low-cost alternatives.

PURPOSE OF VISUAL GUIDANCE SYSTEMS.

Airport visual aids provide pilots with essential information to facilitate their tasks of takeoff, landing, and maneuvering the aircraft on the ground. Visual references are the primary means used below decision altitude (height) DA(H) or for takeoff for pilots to control or monitor flight path. The visual aids that are currently in use have evolved based on operating experience. They provide guidance information a pilot needs for various purposes: to locate the airport and to identify runway location, runway and taxiway edges, thresholds, centerlines of runways and taxiways, visual glide paths, and position on the airport to name but a few. Airport visual aids provide this information in a variety of ways through lighting systems, marking patterns, and signs.

During the visual approach and landing, various system components are designed to provide the pilot with required information to assess the aircraft attitude, heading, and altitude as follows:

- **ROLL GUIDANCE.** During the visual portion of the instrument approach, the pilot relates the wings level or roll orientation of his aircraft to the appearance of approach lighting system (ALS) components having a significant width with respect to the centerline of the ALS. The multiple-barrette wide crossbar located at the 1000-foot station of the MALSR and ALSF-1 systems (figures 1 and 2) serves to provide this visual cue during Cat. I approaches, while the significantly more dense 1000-foot crossbar/red side row light and 500-foot crossbar array of the ALSF-2 system (figure 3) provides even more enhanced roll guidance cues under the Cat. II/III conditions.
- **LATERAL AND VERTICAL GUIDANCE.** Lateral (centerline alignment) guidance is provided primarily by the steady-burning barrette lights of the various approach lighting systems and, to a lesser extent, by the edge lights and surface of the runway itself, if visible. The flashing light portion of the ALS (strokes) is most valuable in achieving early acquisition of the lighting system but, due to the intermittent appearance of the lights, is only somewhat effective in providing lateral guidance. The degree to which the lights of the ALS provide vertical (height) guidance is minimal, although the broad array of supplementary lights within the inner 1000 feet of the ALSF-2 system does serve this purpose to some extent during the final portion of the approach. The visual approach slope indicator (VASI) or precision approach path indicator (PAPI) systems provide significant vertical approach path guidance, but are seldom perceived during precision approaches from their

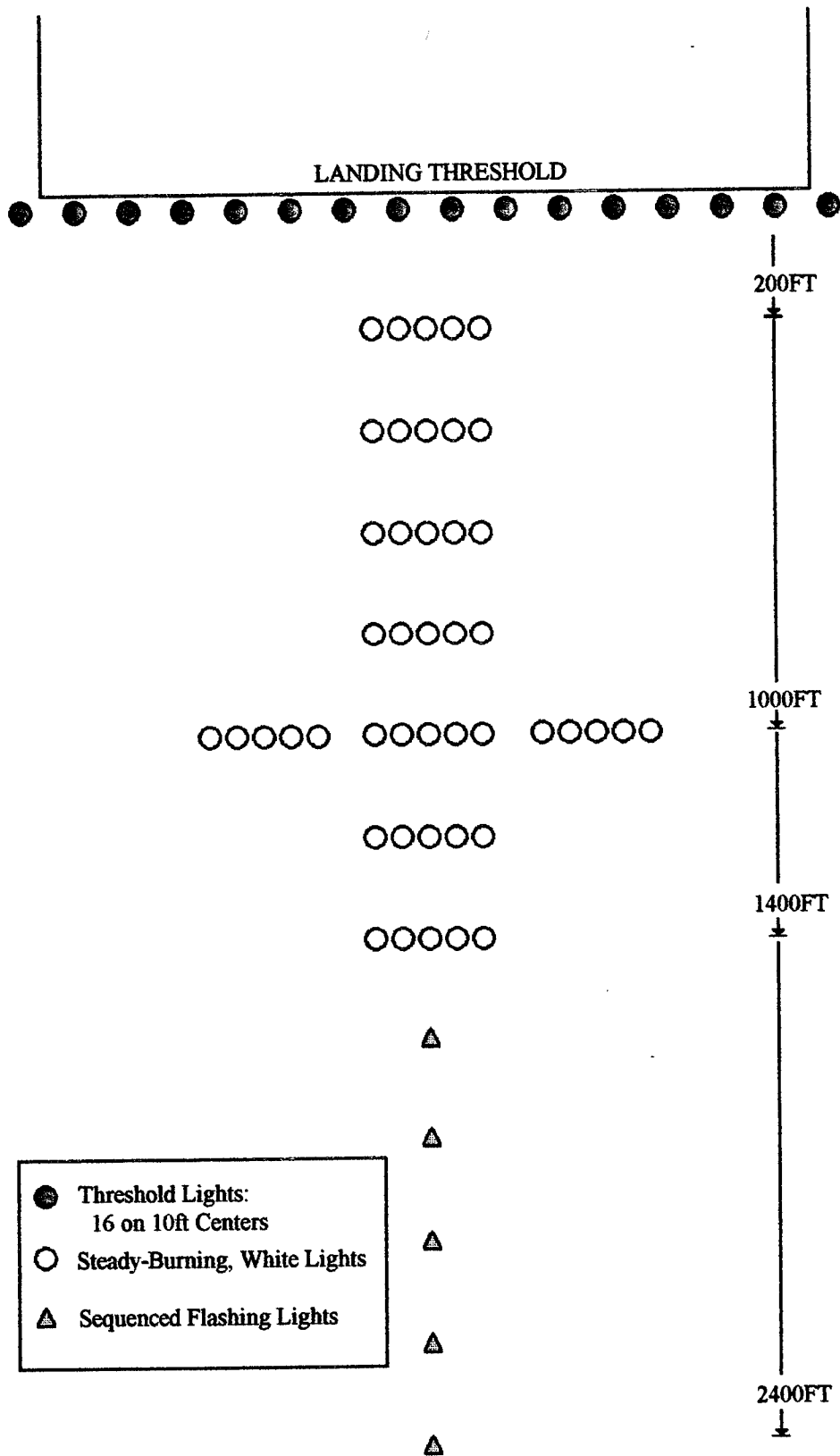

FIGURE 1. MALSR APPROACH LIGHTING SYSTEM

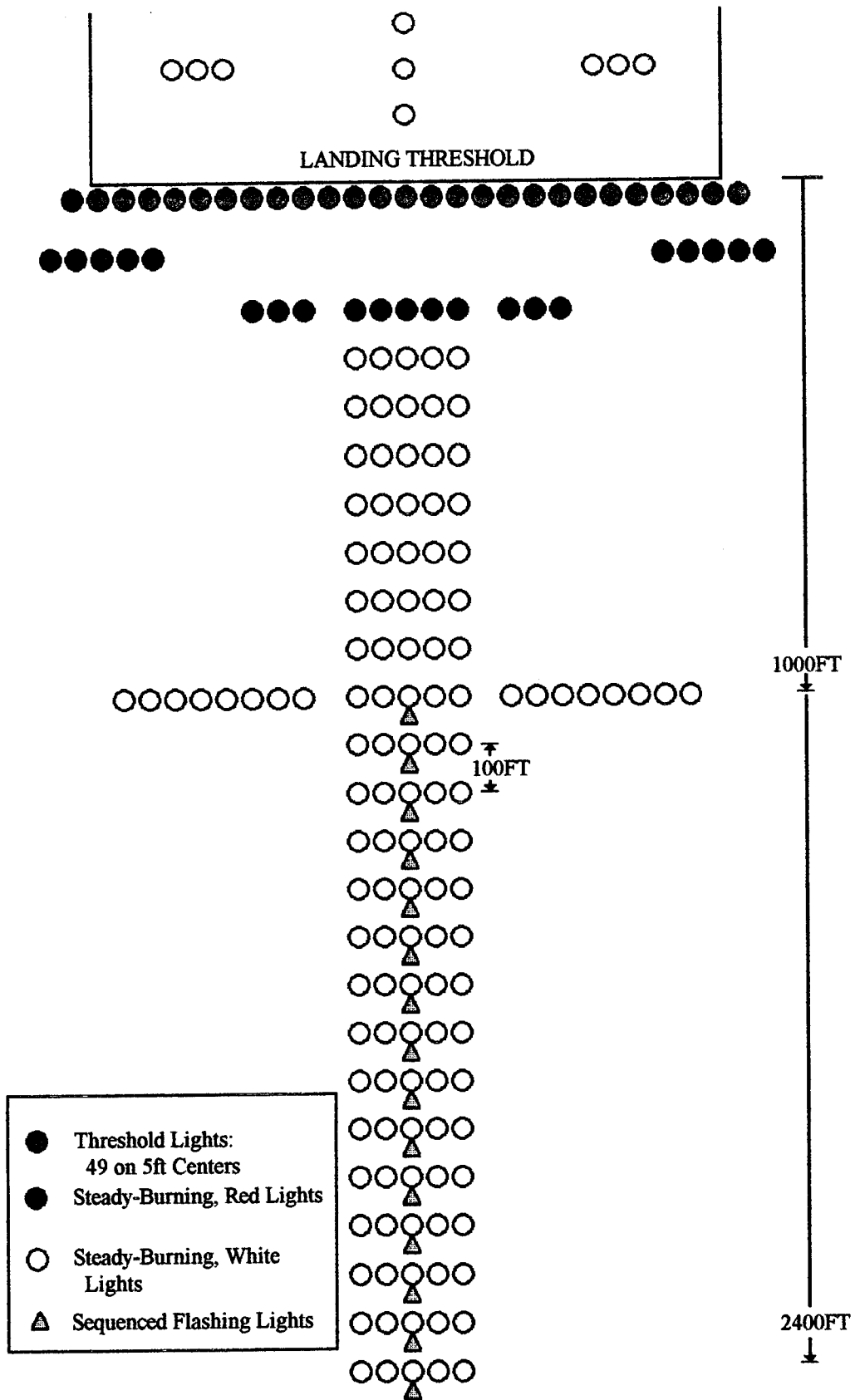

FIGURE 2. ALSF-1 APPROACH LIGHTING SYSTEM

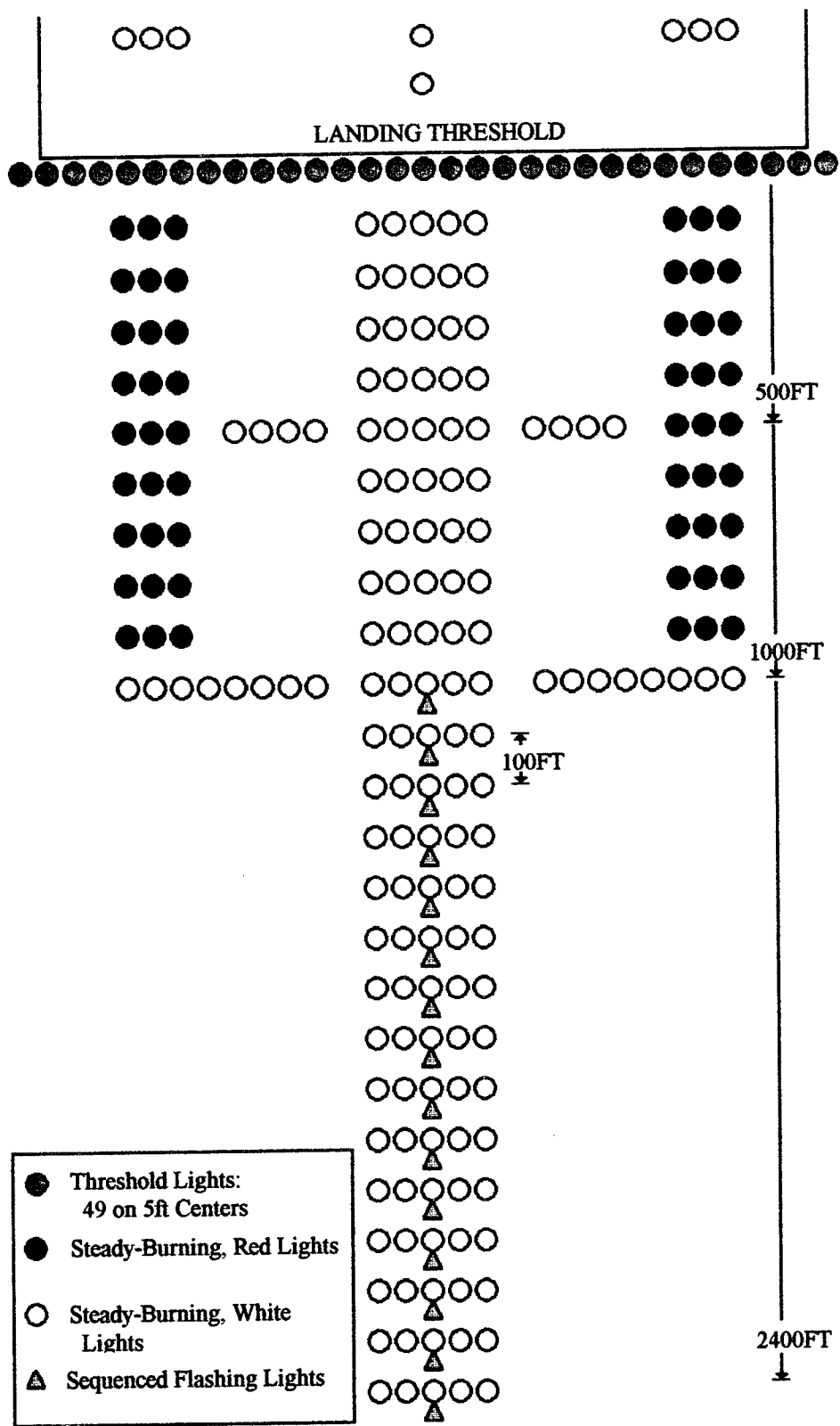

FIGURE 3. ALSF-2 APPROACH LIGHTING SYSTEM

location well past the runway threshold. The perspective provided by the runway edge lights, and even the runway surface, also provides a measure of height guidance, but again is seldom seen until very late in the approach.

- NATURE OF THE RVR/LIGHTING INTERFACE. The Runway Visual Range (RVR) system is used to measure the existing visibility along the runway. It is an instrumentally derived value representing the horizontal distance a pilot can be expected to see down the runway from the approach end and is based on the anticipated visual range of the high-intensity runway lights. High-intensity runway edge lights have an enhanced capability to be perceived in low-visibility (fog, rain, etc.) conditions and are thus the basis upon which RVR measurements are made and reported. Runway lights, if not set to the highest intensity step or provided only in the lesser medium intensity (MIRL) configuration, will result in significantly reduced RVR values.
- RUNWAY EDGE AND THRESHOLD LIGHTS. For the instrument approaches where approach lights are neither required nor provided, the quality of the runway edge and threshold lighting system becomes of critical importance. Initially runways at smaller airports will be provided with a GPS approach capability and may only have low-intensity runway lighting systems. In fact, the lights at a great many local airports consist only of conventional 25-watt home-use lamps enclosed in a Mason jar fixture and are primarily intended only to support VFR operations. Since these runway lighting systems will be the only source of nighttime visual guidance, it is essential that they be provided with FAA approved fixtures of the medium intensity runway light (MIRL) type. The configuration or pattern must also conform to that specified in the FAA Advisory Circular covering runway and taxiway edge lighting systems (AC 150/5340-24).

LIGHTING SYSTEM CREDITS.

Title 14, Part 91.175 (c) (3) of the federal aviation regulations specifies requirements for operation below decision height (DH). The ALS and other visual aids are fundamental to this regulation and to providing the lowest approvable visibility minimums through lighting system credits.

The principal value of approach lighting systems results not from the fact that the lights are able to penetrate the visibility restriction (fog, rain, etc.), but rather from their location in the approach zone of the runway and, in the case of most ALS configurations, the basic fact that they are much closer (approximately 1/2 mile) to the pilot's eye than is the runway threshold. Figures 4 and 5 depict the pilot's forward visibility from a 200-foot DA(H) for reported visibilities of 1/2 and 3/4 statute mile. Without approach lights FAR 91.175 cannot be

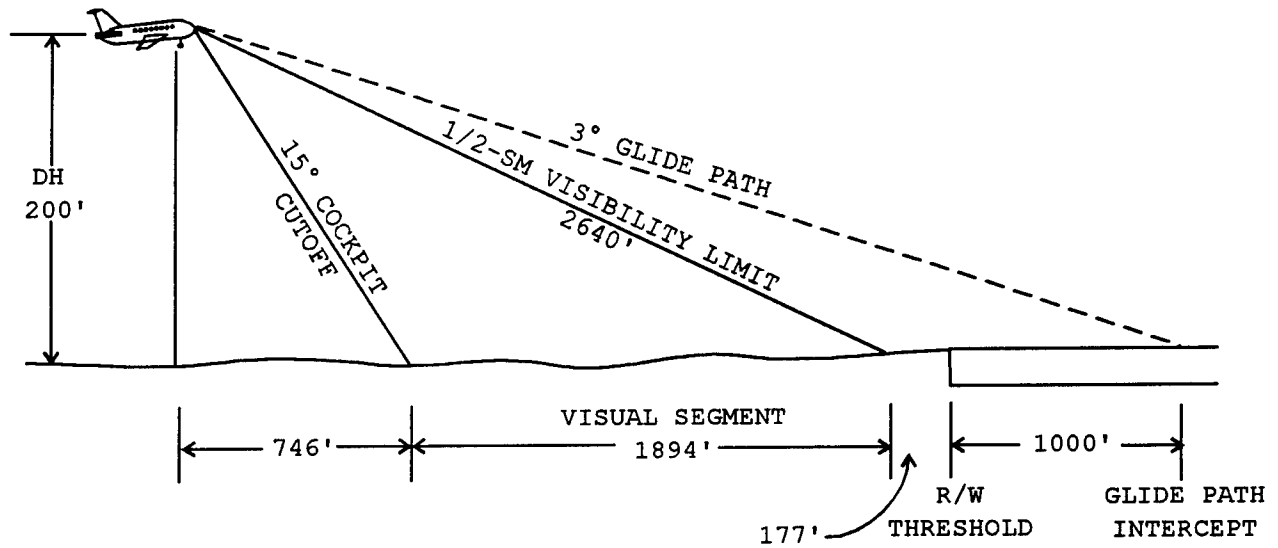

FIGURE 4. ONE-HALF-MILE VISUAL SEGMENT

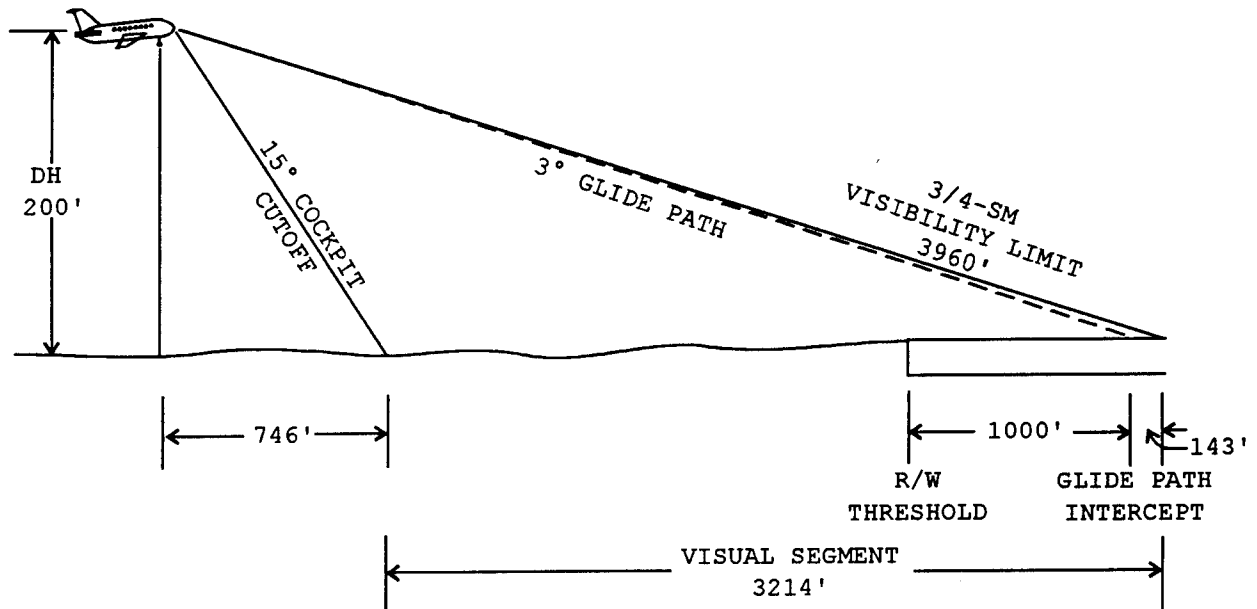

FIGURE 5. THREE-QUARTER-MILE VISUAL SEGMENT

satisfied in visibilities of 1/2 statute mile. Therefore, we would expect to derive credit or lower visibility minimums only for those lighting systems that are sited within the approach area. Runway end identifier light (REIL) systems, visual glide path indicator (VASI and PAPI) systems, and other aids located at or beyond the threshold, by virtue of their less advantageous location, cannot achieve credit toward reduced minimums.

One exception to this rule is that the high intensity runway centerline and touchdown zone lights, due to their brightness and high density configuration, can provide valuable guidance under visibility conditions unique to the lower Cat. I approach conditions (1/2- to 3/4-mile visibilities). The availability of these systems, with approach lights also provided, thus permits reduction of Cat. I minimums from 2400-foot RVR (1/2 mile) to 1800-foot RVR (3/8 mile).

ANALYSIS OF CURRENT MINIMA.

Current minima are predicated on the availability of visual guidance at a point in the approach coincident with the lowest DA(H). The type of approach being accomplished and the accuracy of the electronic approach aids and airborne equipment determine the width and length of approach lights, if any, that will be required to support the approach. The lighting system characteristics, beam spreads and intensities designed to reach the pilot at DA(H) have been developed through considerable research, resulting in standard approved visual guidance systems. These include such systems as the high-intensity approach lighting system with sequenced flashers (ALSF-1/2), the simplified short approach lighting system with runway alignment indicator lights (SSALR), the medium-intensity approach lighting system with runway alignment indicator lights (MALSR), the omnidirectional approach lighting system (ODALS) and the runway end identifier lights (REILS). Each system provides a specific capability, but only some, as explained above, result in minimum reduction credits.

With no visual approach aid, current approach minima are typically limited to 250-foot MDA(H) and 1-mile visibility for a non-precision instrument approach, and to a 200-foot DA(H) and 3/4-mile visibility for a precision approach (figure 6). With standard MALSR, SSALR, or ALSF-1 systems provided, the visibility minimum can be reduced to 1/2-mile (2400' RVR), and an additional reduction to a 3/8-mile (1800' RVR) visibility minimum can be authorized when standard high intensity runway centerline and touchdown zone lighting systems are provided. With the ALSF-2 system installed and appropriately certified crews, aircraft, and ground equipment the lower minima of Cat. II and Cat. III can be authorized.

INSTRUMENT APPROACH (e.g., VOR, NDB, ASR, etc.)					
Approach Light Configuration	HAT MDA(H) in Feet	Aircraft Category A, B, & C		Aircraft Category D	
		Visibility in Statute Miles	TDZ RVR in Feet	Visibility in Statute Miles	TDZ RVR in Feet
No Lights	250	1	5000	1	5000
ODALS, MALS, or SSALS	250	3/4	4000	1	5000
MALSR, SSALR, ALSF-1, or ALSF-2	250	1/2	2400	1	5000
DME Arc - Any Light Config.	500	1	5000	1	5000
PRECISION APPROACH (e.g., FULL ILS, MLS, or PAR)					
Approach Light Configuration	HAT DA(H) in Feet	Aircraft Category A, B, C, & D			
		Visibility in Statute Miles		TDZ RVR in Feet	
ODALS, MALS, SSALS, or No Lights	200	3/4		4000	
MALSR, SSALR, ALSF-1, or ALSF-2	200	1/2		2400	
MALSR, SSALR, ALSF-1, or ALSF-2 w/TDZ & C/L Ltg.	200	Visibility not used below 1/2 mile.		1800	

FIGURE 6. SYSTEM/MINIMA CHART

THE ISSUES.

With regard to the basic question of what changes must be anticipated in providing visual guidance support for GPS instrument approach and landing operations, we believe the answer is none.

The pilot, regardless of the guidance provided during the instrument segment of his approach (i.e. GPS, ILS, or MLS), will be delivered to, or positioned at, a point in space from which he/she will be expected to make the transition to use of visual references for the remainder of the approach and landing. The means by which the aircraft has reached the minimum descent altitude/height MDA(H) or decision altitude/height DA(H) matters little, so long as the instrument system has sufficient accuracy to insure that the aircraft safely avoids obstacles.

As stated previously, the only justification for the cost and effort involved with providing an approach lighting system extending out into the approach zone is to place the lights closer to the pilot at DA(H). In Category I conditions with a prevailing 2400' RVR, it is highly unlikely that a pilot will be able to see any of the runway lights and certainly not the PAPI signal some 1000' past the runway threshold. REIL lights, being of an intensity much higher than other steady-burning lights, may be needed but will provide little runway orientation (direction) information. Slant visibility (the pilot's real visual range) may be considerably less than RVR values. Therefore, in the lower visibility situations, there is no alternative to lights extending into the approach zone for providing runway alignment guidance and early visual acquisition to the pilot. This is especially true for the lowest Cat. I, II and higher Cat. III visibility conditions which require that a portion of the approach be based on visual reference. Cat. III operations are predicated upon having suitable navigation guidance at least to touchdown, making visual guidance less of a factor and placing the emphasis upon rollout and taxi visual reference.

The GPS approaches being approved over the next two years will be based on non-DGPS guidance. Therefore minimums such as those now authorized for conventional very high frequency omni-directional range (VOR) or non-directional beacon (NDB) approaches will typically apply, and additional lighting system costs may be minimized.

Once DGPS/WAAS facilities are installed, affording the lowest Cat. I approach capability, a 1/4-mile visibility minimum penalty (from 1/2 to 3/4 mile) will have to be accepted where funding for approach lighting systems cannot be immediately justified. It seems very likely that the attainment of minimums of 200-foot DH and 3/4-mile visibility will satisfy the needs of a great many of the smaller airports at which no precision approach capability was previously available. For those airports where economic

considerations mandate the lowest possible minimums, the cost/benefit calculations will probably justify the additional cost of installing the appropriate approach lighting systems.

The question arises of whether we might be able to provide an approach lighting system of simpler and less costly nature that would still be capable of supporting lowest Category I (200' DA(H) and 1/2-mile visibility) GPS approaches. Would just a few lights placed out in the approach zone, a lead-in lighting configuration of sorts, be sufficient to provide suitable visual reference in the last thousand feet or so until visual reference is established with the runway lights?

Several basic and commonly accepted characteristics of any effective approach lighting system must be taken into consideration in attempting to answer this question. They are as follows:

- The approach lighting must be of a unique pattern so as not to be confused with other ambient lighting sources or arrays that may be located within or near to the approach area. Roadway lighting, for example, crossing the approach path might, when viewed initially by the pilot, appear as the simple line of lead-in lights defining guidance to the runway.
- The density of lights within the approach lighting system must be such that the additive effect of the large number of lights will provide sufficient intensity to penetrate some distance through the obscuring medium (fog, snow, rain, etc.) without requiring individual lights of such intensity as to create a dangerous glare problem. This mandates the use of bars of lights (barrettes) rather than single very high intensity lights within the system.
- The spacing of individual segments of the lighting system must be such that the visible portion of the array (the visual segment) appears as a continuous line of lights, providing the necessary (runway) alignment information to the pilot. A spacing on the order of 200 feet has been found to be about the maximum that will insure that the sequential pattern of lights will appear linear and adequately indicate direction.
- Intensity must be controllable to accommodate day/night and variable visibility conditions.
- Crashworthiness design of the lighting systems must not contribute undue hazards to the runway environment.

If we accept these characteristics as essential for an effective system, then we must eliminate the possibility of using just a few bright lights widely spaced throughout the visual segment of the approach area and find ourselves compelled to accept the need for a rather closely spaced array of light barrettes having a

well-defined unique pattern. We are also forced to conclude that the simpler and less costly type of lead-in lights will most probably not provide the required low-visibility guidance.

This is not to say, however, that our existing MALSR and ALSF-2 systems are optimum with regard to efficiency and/or economy. From the standpoint of basic characteristics (i.e., shape, length, etc.) they are widely accepted as being suitable for the purpose intended, being the result of protracted developmental efforts. Nevertheless, there are still certain areas within which they might be improved and made much more cost efficient. We should be concerned with investigating the possibility of reducing the number of individual lights presently specified for use in our systems, so long as this can be accomplished without jeopardizing the effectiveness of the configuration. For example, the standard number of lights in each ALS barrette, now five, might be reduced to three with virtually no loss of visual effect. The considerable array of steady-burning lights in the outer segment of the ALSF-2 system might prudently be reduced, or even eliminated, since the condenser discharge (strobe) lights now provided and collocated might well suffice in providing the early acquisition and alignment guidance needed. Every light fixture eliminated reduces the attendant cost of installation (i.e., supporting structures, cabling, etc.) and maintenance. Energy costs, a continuing expense, would also be reduced significantly. One possible modification to the standard ALSF-2 lighting system is depicted in figure 7.

The concept of cost reduction through simplification of existing lighting systems is not unique to certain of us within the FAA visual guidance field. Airfield lighting specialists in the United Kingdom have been investigating and encouraging support for such efforts for several years now, and we would certainly recommend establishing closer liaison with these individuals. In addition, a study to determine the feasibility of achieving greater economy in the installation, operation, and maintenance of approach lighting systems through reduction in the number of lights required should be initiated. An initial evaluation of reduced light density ALS configurations could be accomplished utilizing the enhanced visual presentation of the FAA Boeing 727 Flight Simulator. Recommendations made subsequently to this simulator evaluation would then have to be validated through actual flight testing.

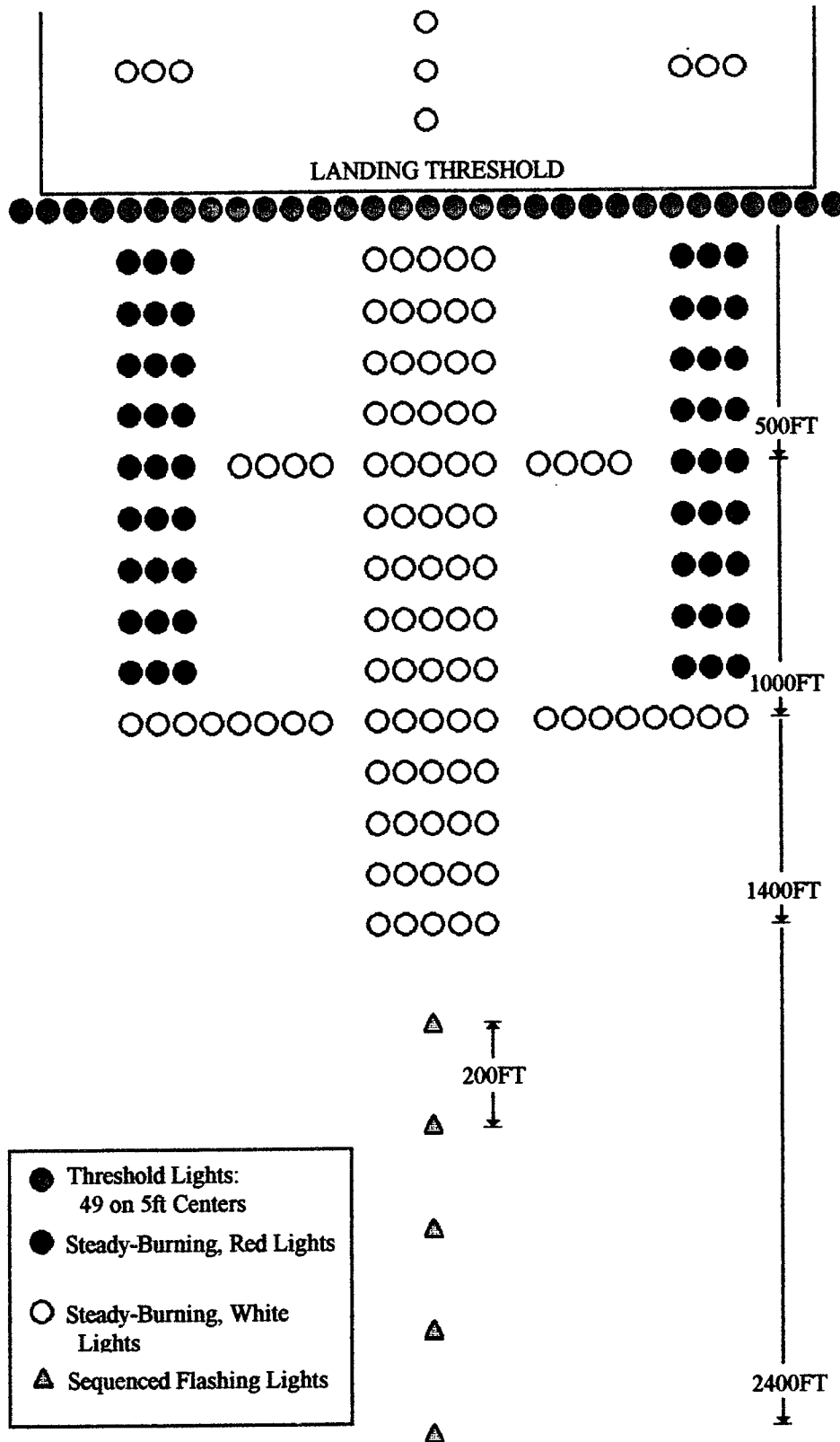

FIGURE 7. MODIFIED ALSF-2 SYSTEM

RECOMMENDATIONS

In summary, we offer the following as our recommendations concerning this issue:

1. The currently established approach categories (Non-Precision, and Precision Cat. I, II, and III) should be retained regardless of the ground-based or space-based (GPS) navigational system.
2. Approach lighting systems currently required for the lowest minimums during ILS/MLS approach and landing operations should also be required for the corresponding precision GPS approach and landing operations.
3. A study to determine the feasibility of achieving greater economy in the installation, operation, and maintenance of approach lighting systems through reduction in the number of lights required should be initiated as a joint effort involving the Flight Standards Service, the Office of Airports Safety and Standards, industry, and the Technical Center.
4. The MALSR configuration is the least complex that may be expected to provide the critical visual approach guidance required to support Category I operations.

UNCLASSIFIED

UNCLASSIFIED

