

NATIONAL AIR INTELLIGENCE CENTER



MULTIPLE DIMENSIONAL ACOUSTO-OPTIC DIFFRACTION AND MULTIPLE
DIMENSIONAL ACOUSTO-OPTIC DEVICE

by

Zhao Qida, Hu Taiyi, et al.

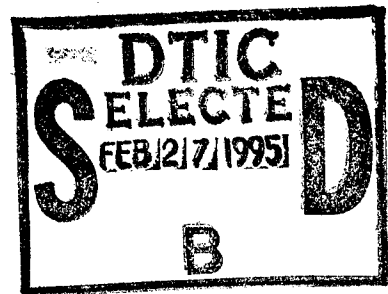

19950213 040

Approved for public release;
Distribution unlimited.

HUMAN TRANSLATION

NAIC-ID(RS)T-0397-94 3 January 1995

MICROFICHE NR: 95C000012

MULTIPLE DIMENSIONAL ACOUSTO-OPTIC DIFFRACTION AND MULTIPLE
DIMENSIONAL ACOUSTO-OPTIC DEVICE

By: Zhao Qida, Hu Taiyi, et al.

English pages: 16

Source: Shengxue Xuebao, Vol. 16, Nr. 6, November 1991;
pp. 450-457

Country of origin: China

Translated by: SCITRAN

F33657-84-D-0165

Requester: NAIC/TATA/J.M. Finley

Approved for public release; Distribution unlimited.

DTC QUALITY INSPECTED 4

THIS TRANSLATION IS A RENDITION OF THE ORIGINAL FOREIGN TEXT WITHOUT ANY ANALYTICAL OR EDITORIAL COMMENT STATEMENTS OR THEORIES ADVOCATED OR IMPLIED ARE THOSE OF THE SOURCE AND DO NOT NECESSARILY REFLECT THE POSITION OR OPINION OF THE NATIONAL AIR INTELLIGENCE CENTER.

PREPARED BY:

TRANSLATION SERVICES
NATIONAL AIR INTELLIGENCE CENTER
WPAFB, OHIO

GRAPHICS DISCLAIMER

All figures, graphics, tables, equations, etc. merged into this translation were extracted from the best quality copy available.

Accession For	
NTIS GRA&I	<input checked="" type="checkbox"/>
DTIC TAB	<input type="checkbox"/>
Unannounced	<input type="checkbox"/>
Justification	
By _____	
Distribution/ _____	
Availability Codes	
Dist	Avail and/or Special
A-1	

STOP HERE

MULTIPLE DIMENSIONAL ACOUSTO-OPTIC DIFFRACTION AND MULTIPLE DIMENSIONAL ACOUSTO-OPTIC DEVICE

By Zhao Qida, Hu Taiyi, Cai Fengyi, Dong Xiaoyi, Sheng Qiuqin,
and Zhang Jianzhong
(Department of Applied Physics, Beijing Polytechnic University)
Received May 11, 1990

Abstract A set of coupled wave equations for multiple dimensional acoustooptic diffraction with multiple acoustic waves along different directions is put forward and its solutions are derived. The characteristics of the diffraction efficiency, compression, cross modulation, and intermodulation intensities are analysed theoretically. The theoretical results are supported by experimental measurements through our new multiple dimensional acoustooptic devices.

A. Introduction

Until now, coupled wave equations for both normal and abnormal acousto-optic interactions with a single ultrasonic wave along the same direction and their solutions have been derived[1-3]. On this basis, coupled wave equations for both normal and abnormal simultaneous acousto-optic interactions with ultrasonic waves of multiple frequencies along the same direction and their solutions have also been derived[4-6]. This article further establishes coupled wave equations for multiple dimensional acousto-optic interactions and derives their solutions. By multiple dimensional acousto-optic interactions, we mean that independent ultrasonic waves traveling along different directions are introduced into an identical acousto-optic medium, and interact with a beam of light to form multiple diffraction light waves in the space, thus loading multiple sets of information into a single beam of light.

Because ultrasonic waves along different directions interact /451 with a single beam of light at the same time, major diffraction light produced by acoustic waves along one direction is diffracted again by acoustic waves along other directions to form the corresponding intermodulation light beams and each major diffraction light is decreased due to compression and cross

modulation. Since the acoustic waves travel along different directions, the non-linear effects produced by them are more complex than those produced by the acoustic wave along the same direction and this article discusses the various effects produced by interaction of multiple dimensional ultrasonic waves with light wave.

B. Multiple Dimensional Acousto-optic Coupled Wave Equations

The basic geometric relationship of multiple dimensional acousto-optic interaction is shown in Fig.1 and frequency is $f_m (m = 1, 2, \dots, N)$. Where N is the dimension number of the light waves). When the acoustic wave of m th dimension travels along a certain direction in the $x y$ plane, the angle between directions of two neighboring acoustic waves equals $\theta_m = \pi/N$. The light impacts the $x y$ plane at the θ angle with the z axis. The diffracted light produced by the interaction of incident light with a beam of acoustic waves further interacts with other acoustic waves to produce secondary and multiple diffractions which form multiple dimension diffracted light with frequency shifts being $f = \sum_{m=1}^N n_m f_m$, where n_m represents the diffraction level of the acoustic wave of m th dimension and can be any positive or negative integer and zero. The interaction level of light waves in space is $D = \sum_{m=1}^N |n_m|$.

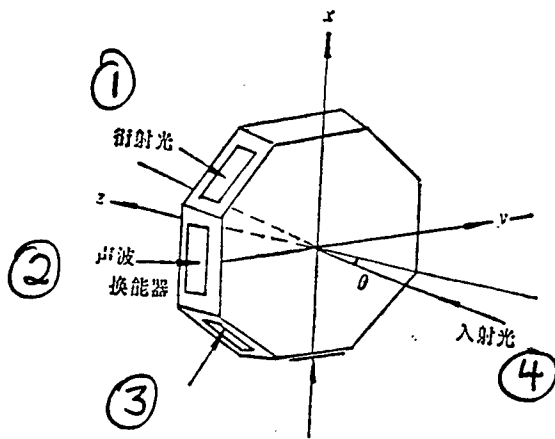

Figure 1. Geometric relationship of four dimension acousto-optic interaction.

Key to Figure 1: (1) Diffracted light; (2) Acoustic wave; (3) energy transformer; (4) incident light.

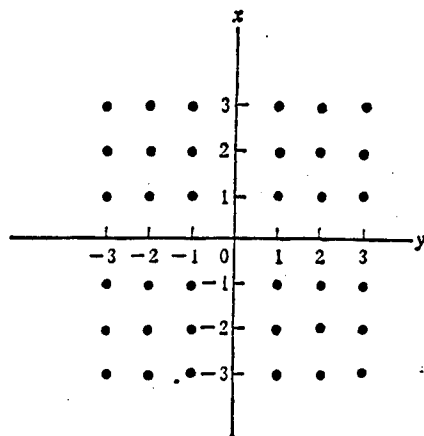

Figure 2. Distribution of two dimensional acousto-optic diffracted light.

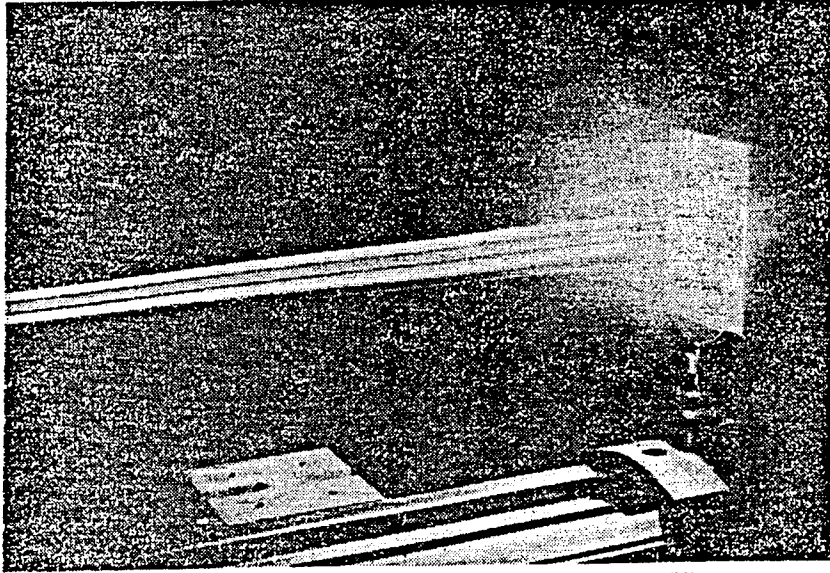

Figure 3. Photo of two dimensional acousto-optic interaction experiment.

Figure 2 shows the distribution of light spots formed by perpendicular two dimensional acousto-optic interaction and Figure 3 is a photo of the experiment.

Let circular frequency and wave vector of the incident light in vacuum be ω and k , respectively; the refractive index of the light in the medium is μ_0 ; circular frequency and wave vector of m th dimension ultrasonic waves in the medium is ω_m^* and k_m^* , respectively; and we assume multiple dimensional ultrasonic waves along different directions are all planar waves; then the strain tensor of the ultrasonic wave is

$$\begin{aligned}
 S(r, t) &= \sum_{m=1}^N s_m S_m \sin(\omega_m^* t - k_m^* \cdot r) \\
 &= \frac{1}{2i} \sum_{m=1}^N s_m S_m \{ \exp[i(\omega_m^* t - k_m^* \cdot r)] - c.c. \}, \quad (1)
 \end{aligned}$$

where s_m is the unit strain tensor of the m th dimension acoustic wave.

Because of acousto-optic effects, the incident light wave couples with the acoustic wave to produce many polarized waves with multiple frequencies, and these polarized waves produce light radiation with the new frequencies, namely diffracted light[3-7]. In the case of multiple acoustic waves, the circular frequency is

$$\omega_{(\bar{n})} = \omega + \sum_{m=1}^N n_m \omega_m^*$$

and wave vector is $\mathbf{k}_{(\bar{n})} = \mu_0 \mathbf{k} + \sum_{m=1}^N n_m \mathbf{k}_m^*$. Thus total electric field of incident and diffracted light waves developed according to the planar wave is

$$\begin{aligned} E(\mathbf{r}, t) = & \exp(i\omega t) \sum_{n_1=-\infty}^{\infty} \sum_{n_2=-\infty}^{\infty} \cdots \sum_{n_N=-\infty}^{\infty} \mathbf{e}_{(\bar{n})} E_{(\bar{n})}(z) \\ & \cdot \exp \left[i \left(\sum_{m=1}^N n_m \omega_m^* t - \mathbf{k}_{(\bar{n})} \cdot \mathbf{r} \right) \right], \end{aligned} \quad (2)$$

where $\mathbf{e}_{(\bar{n})}$ is the unit vector along direction $E_{(\bar{n})}$, and (\bar{n}) represents $(n_1, n_2, \dots, n_{N-1}, n_N)$.

The non-linear polarized vector produced by acousto-optic interaction is

$$\begin{aligned} P(\mathbf{r}, t) = & \epsilon_0 \chi : \mathbf{S}(\mathbf{r}, t) \cdot E(\mathbf{r}, t) \\ = & \frac{\epsilon_0}{2i} \sum_{n_1=-\infty}^{\infty} \sum_{n_2=-\infty}^{\infty} \cdots \sum_{n_N=-\infty}^{\infty} \sum_{m=1}^N \{ \chi : \mathbf{s}_m \cdot \mathbf{e}_{(\bar{n}-\bar{a}_m)} S_m E_{(\bar{n}-\bar{a}_m)}(z) \\ & - \chi : \mathbf{s}_m \cdot \mathbf{e}_{(\bar{n}+\bar{a}_m)} S_m E_{(\bar{n}+\bar{a}_m)}(z) \} \exp [i(\omega_{(\bar{n})} t - \mathbf{k}_{(\bar{n})} \cdot \mathbf{r})], \end{aligned} \quad (3)$$

where χ is non-linear polarizability tensor of the medium, $(\bar{n} - \bar{a}_m)$ represents $(n_1, n_2, \dots, n_{m-1}, n_m - 1, n_{m+1}, \dots, n_{N-1}, n_N)$, and $(\bar{n} + \bar{a}_m)$ represents $(n_1, n_2, \dots, n_{m-1}, n_m + 1, n_{m+1}, \dots, n_{N-1}, n_N)$.

When equations (1)-(3) are substituted into the light wave equation

$$\nabla^2 E - \frac{1}{c^2} \epsilon \cdot \ddot{E} = \frac{1}{c^2 \epsilon_0} \ddot{P}, \quad (4)$$

By analogy with calculations of [4,6], note the acoustic strain s_m , optical field $e_{(n)}$ is a space tensor and vector produced by acoustic waves not along the same direction. For an isotropic medium, the coupled wave equation can be obtained under the first order approximation:

$$\frac{dE_{(n)}(z)}{dz} - i\Delta k_{(n)} E_{(n)}(z) - \sum_{m=1}^N \frac{k_m \Delta \mu_m}{2 \cos \theta_m} [E_{(n+a_m)}(z) - E_{(n-a_m)}(z)], \quad (5)$$

where k_m is the component of incident light wave vector k in the plane defined by the z axis and acoustic wave k_m^* . θ_m is the angle formed by k_m and the z axis, $\Delta \mu_m = -\frac{1}{2} \mu^3 p S_m$ is sound-caused change of the refractive index, p is effective acousto-optic coefficient and μ is refractive index of the diffracted light in the medium. For isotropic medium: $\mu = \mu_0$. In equation (5):

$$\Delta k_{(n)} = \sum_{m=1}^N n_m k_m^* \tan \theta_m + \sum_{m=1}^N \frac{(n_m k_m^*)^2}{\cos \theta_m} / 2\mu_0 k, \quad (6)$$

is the difference between the free light wave vector and polarized wave vector of diffracted light along the z axis, namely momentum mismatch.

The multiple dimensional coupled wave equation can also be obtained for anisotropic medium [5,6]. However, considering that the multiple dimensional acoustic waves travel along different directions, it is desired to have a larger value of the component corresponding to the vector of acousto-optic coefficient in the medium and to obtain asymmetric diffracted light field in each dimension. Therefore, the isotropic medium should be used, especially for a situation higher than two dimensional.

In multiple dimensional acousto-optic interaction, the light interacts with multiple acoustic waves along different directions at the same time. In Bragg diffraction region, incident couple of light should be equal to Bragg angle. It is difficult, however, for the same incident light to satisfy this requirement simultaneously for multiple dimensional acoustic waves along

different directions. This is to say, acoustic waves in each dimension do not satisfy the condition of momentum match. In the Raman-Nath diffraction region, when incident light is perpendicular to the plane formed by acoustic waves in each dimension. (Fig.1 when $\theta = 0$), diffraction efficiency will be highest for the acoustic wave in each dimension and multiple dimensional diffracted light in space will be formed. Therefore, we will mainly discuss results of isotropic Raman-Nath diffraction.

Boundary conditions are known to be $E_{(z)}(0) = E_0$, $E_{(z)}(L) = 0$, and we solve equation (5) under conditions of direct incidence to obtain the solution for $z = L$.

$$E_{(z)} = E_0 \prod_{m=1}^N J_{n_m}(V_m), \quad (7)$$

where J_{n_m} is the Bessel function of integer order n_m and $V_m = k_m \Delta \mu_m L_m / \cos \theta_m$ is the phase shift caused by m th dimension acousto-optic interaction.¹ From equation (7) diffraction efficiency of each diffraction light is:

$$I_{(z)} = \frac{|E_{(z)}(L)|^2}{|E_0|^2} = \left| \prod_{m=1}^N J_{n_m}(V_m) \right|^2. \quad (8)$$

In comparison with the solution for one dimension acousto-optic interaction $E_n = E_0 J_n(V)$ (where n is the diffraction order and V is phase shift caused by one dimensional acousto-optic interaction), if we consider multiple acousto-optic diffraction as the multiple diffraction of light waves by multiple acoustic waves, the physical meaning of solution (7) is obvious.

Since the Raman-Nath diffraction of each dimensional acoustic wave can produce multiple major diffracted light, they will form intermodulation light beams in space when diffracted again by acoustic waves along other directions. During these

¹ In the equation for V_m , L_m is length of m th acousto-optic interaction and each dimension has the same value of L . In the case of direct incidence, $k_m = k$, $\theta_m = 0$. See also equation (9).

processes non-linear effects such as cross-modulation and compression appear and intensity of major diffracted light in each dimension decreases due to cross-modulation and compression. The first order major diffraction pattern of the m th acoustic signal is further diffracted to become cross-modulation of the second order inter-modulation pattern due to the existence of n th acoustic signal and is expressed as $M_{m,n}$. In addition, the first order diffraction pattern may be coupled back to zero order pattern (self compression) and the sum of these two effects is expressed as compression c_1 . The analysis results of each major diffraction pattern, intermodulation pattern, cross-modulation and compression of multiple acousto-optic diffraction can be obtained from the solution of coupled wave equation (8).

Table 1 gives the Raman-Nath diffraction results of two dimensional independent acoustic signals. The last column gives the solutions of minor signals when it is $|V_m/2| \ll 1$ and the Bessel function cutoff series is used.

Table 1. Analytical results of second order acousto-optic interaction

	(符号)	解析解 2	小信号解 3
4 主衍射模 衍射效率	$I_{1,0}$	$ J_1(V_1)J_0(V_2) ^2$	$(\frac{V_1}{2})^2 [1 - (\frac{V_1}{2})^2 - 2(\frac{V_2}{2})^2]$
	$I_{2,0}$	$ J_2(V_1)J_0(V_2) ^2$	$\frac{1}{4}(\frac{V_1}{2})^4 [1 - \frac{2}{3}(\frac{V_1}{2})^2 - 2(\frac{V_2}{2})^2]$
	$I_{3,0}$	$ J_3(V_1)J_0(V_2) ^2$	$\frac{1}{36}(\frac{V_1}{2})^6 [1 - 2(\frac{V_2}{2})^2]$
5 互调制模(2级)	$I_{1,1}$	$ J_1(V_1)J_1(V_2) ^2$	$(\frac{V_1}{2})^2 (\frac{V_2}{2})^2 [1 - (\frac{V_1}{2})^2 - (\frac{V_2}{2})^2]$
6 互调制模(3级)	$I_{2,1}$	$ J_2(V_1)J_1(V_2) ^2$	$\frac{1}{4}(\frac{V_1}{2})^4 (\frac{V_2}{2})^2 [1 - \frac{2}{3}(\frac{V_1}{2})^2 - (\frac{V_2}{2})^2]$
7 压缩	c_1	$1 - \frac{2}{V_1} J_1(V_1)J_0(V_2) ^2$	$(\frac{V_1}{2})^2 + 2(\frac{V_2}{2})^2$
8 交叉调制	$M_{1,1}$	$1 - J_0(V_2) ^2$	$2(\frac{V_2}{2})^2$

Key: (1) Symbol; (2) Analytical solution; (3) Minor signal solution; (4) Diffraction efficiency of major diffraction pattern; (5) Inter-modulation pattern (second order); (6) Inter-modulation pattern (third order); (7) Compression; (8) Cross-modulation.

Table 2. Analytical results of Nth dimension acousto-optic interaction

	符号	小信号解
3 主衍射模 衍射效率	$I_{1,0,0\dots}$	$(\frac{V_1}{2})^2 [1 - (\frac{V_1}{2})^2 - 2 \sum_{i=1}^N (\frac{V_i}{2})^2]$
	$I_{2,0,0\dots}$	$\frac{1}{4} (\frac{V_1}{2})^4 [1 - \frac{2}{3} (\frac{V_1}{2})^2 - 2 \sum_{i=1}^N (\frac{V_i}{2})^2]$
	$I_{3,0,0\dots}$	$\frac{1}{36} (\frac{V_1}{2})^6 [1 - 2 \sum_{i=1}^N (\frac{V_i}{2})^2]$
4 互调制模 (3 信号 3 级)	$I_{1,1,1,0,0\dots}$	$(\frac{V_1}{2})^2 (\frac{V_2}{2})^2 (\frac{V_3}{2})^2 [1 - (\frac{V_1}{2})^2 - (\frac{V_2}{2})^2 - (\frac{V_3}{2})^2 - 2 \sum_{i=4}^N (\frac{V_i}{2})^2]$
5 互调制模 (3 信号 4 级)	$I_{2,1,1,1,0,0\dots}$	$\frac{1}{4} (\frac{V_1}{2})^4 (\frac{V_2}{2})^2 (\frac{V_3}{2})^2 [1 - \frac{2}{3} (\frac{V_1}{2})^2 - (\frac{V_2}{2})^2 - (\frac{V_3}{2})^2 - 2 \sum_{i=4}^N (\frac{V_i}{2})^2]$
6 压缩	$c_{1,0,0\dots}$	$(\frac{V_1}{2})^2 + 2 \sum_{i=2}^N (\frac{V_i}{2})^2$
7 交叉调制	$M_{1,2}$	$2(\frac{V_1}{2})^2$

Key: (1) Symbol; (2) Minor signal solution; (3) Diffraction efficiency of major diffraction pattern; (4) Inter-modulation pattern (three signals, third order); (5) Inter-modulation pattern (three signals, fourth order); (6) Compression; (7) Cross-modulation.

Table 2 gives the solution of a major signal of a Nth dimensional signal. The subscripts n_1, n_2, \dots, n_N of I_{n_1, n_2, \dots, n_N} in Tables 1 and 2 are interchangeable. The sound-caused phase shift V_m in equation (8) may be replaced by ultrasonic power P_{am} , [2, 3] then we have:

$$\begin{aligned}
 I_{(s)} &= \left| \prod_{m=1}^N J_{n_m}(V_m) \right|^2 = \left| \prod_{m=1}^N J_{n_m} \left(\frac{2\pi\Delta\mu_m L_m}{\lambda_0} \right) \right|^2 \\
 &= \left| \prod_{m=1}^N J_{n_m} \left[\frac{\pi}{\lambda_0} \left(\frac{2M_2 L_m P_{am}}{H_m} \right)^{1/2} \right] \right|^2 \quad (9)
 \end{aligned}$$

where λ_0 is wavelength of light in a vacuum, P_{am} is mth dimensional ultrasonic power, L_m is length of mth dimensional acousto-optic interaction or length of energy converter, H_m is width of mth dimension energy converter, M_2 is acousto-optic optimum value of acousto-optic medium. Values L and H of multiple dimension acousto-optic device in each dimension may be made equal, respectively, in order to achieve symmetric distribution of diffracted light in each dimension under the same

/455

driving power. Intensity of diffracted light can be controlled by changing the electric driving power exerted on the energy converter, namely, altering ultrasonic power in each dimension.

C. Experimental Content and Results

The experiment apparatus is shown in Fig.4. the incident light produced by a He-Ne laser device is perpendicular to the plane of acoustic waves and independent ultra high frequency signal generators load the signals on energy converters in each dimension to produce ultrasonic wave signals along multiple directions.

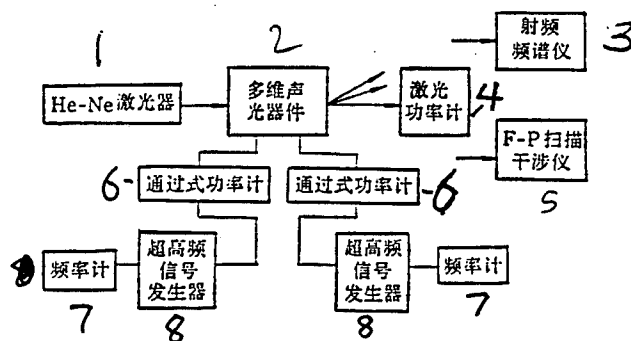

Figure 4. Diagram of experiment apparatus.

Key: (1) He-Ne laser device; (2) Multiple dimensional acousto-optic device; (3) Radio frequency spectrometer; (4) Laser power meter; (5) F-P scan interferometer; (6) Passage power meter; (7) Frequency meter; (8) Ultra high frequency signal generator.

If output power of an ultra high frequency signal converter is altered, ultrasonic power will change causing changes in sound-caused phase shift V_m . Variation of diffraction efficiency of each major diffracted light and intermodulation light in each dimension caused by multiple dimensional acousto-optic interaction was determined in terms of change of $(V_m/2)^2$. Part of theoretical and experimental results of two dimensional acousto-optic interaction is the case of minor signal is shown in Figures. Fig.5 and 6 show curves for relationship between

diffraction efficiency of part of major diffracted light and intermodulation light and the change of sound-caused phase shift when two dimensional sound-caused phase shifts change simultaneously by the same value.

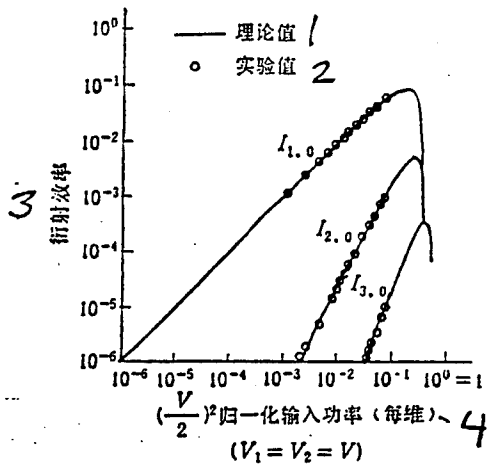

Figure 5. Diffraction efficiency of major diffraction pattern of two dimensional acousto-optic diffraction.

Key: (1) Theoretical value; (2) Experimental value; (3) Diffraction efficiency; (4) Normalized input power (each dimension).

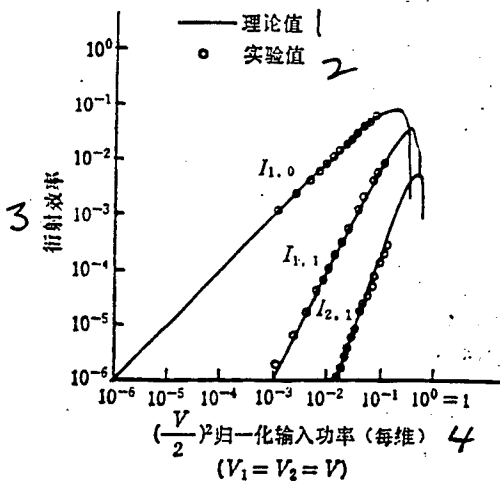

Figure 6. Diffraction efficiency of intermodulation pattern of two dimensional acousto-optic diffraction.

Key: (1) Theoretical value; (2) Experimental value; (3) Diffraction efficiency; (4) Normalized input power (each dimension).

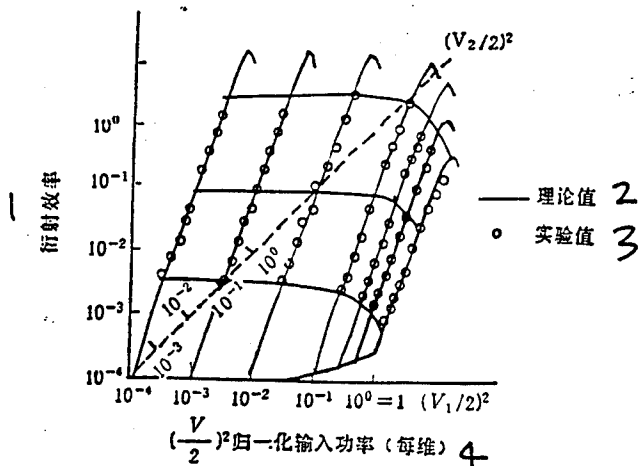

Figure 7. Relationship between change of first order major diffraction efficiency and that of two dimensional driving power. Note: Vertical coordinate in the figure is $I_{0,1}$. Key: (1) Diffraction efficiency; (2) Theoretical value; (3) Experiment value; (4) Normalized input power (each dimension).

Figure 7 shows relationship between change of first order major diffracted light $I_{0,1}$ in one dimension and that of sound-caused phase shifts in another dimension when the latter is used as the reference variable.

Central frequency and band width of two to four dimensional acousto-optic devices were also measured and frequency spectra of each diffracted light were determined by radio frequency spectrometers and F-P scan interferometers. First and second order diffraction efficiency can be more than 32% and 20%, respectively, reaching their theoretical maxima. Modulation band width can be 18-20 Mhz.

D. A Few Questions in the Design of Multiple Dimensional Acousto-optic Devices

Based on the above theoretical analysis, we designed and manufactured two- to four-dimensional Raman-Nath acousto-optic devices. In each dimension, diffracted light of positive and negative fourth order or higher can be obtained to form a diffracted light field in the space. Several questions in the design are discussed below:

1. Acousto-optic Medium Material

Isotropic heavy flint glass was used because it has a larger acousto-optic optimum value in isotropic medium ($M_2 = 6.50 \times 10^{-15} \text{ s}^3/\text{kg}$), and higher sound speed (3720 m/s), thus giving higher diffraction efficiency and higher modulation speed.

2. Length of Acousto-optic Interaction

$L \leq L_0/2$, was normally chosen for Raman-Nath acousto-optic device where $L_0 = \Lambda^2 \mu \cos \theta / \lambda_0$ is characteristic length. In the equation Λ is length of acoustic waves. Calculation shows that when ultrasonic frequency is at 30-35 Mhz, L_0 is equal to 42.5-31.1 mm and a smaller L value should be used to ensure that acousto-optic interaction occurs in the Raman-Nath region. In addition, it can be seen from equation (9) that the higher the L value, the higher the diffraction efficiency, so the same diffraction efficiency can be achieved with smaller ultrasonic power P_a and less device heating and the same L values of 15-20 mm were employed and the same P value was used for all the dimensions.

3. Central Frequency

The higher the central frequency of the acousto-optic device, the shorter the characteristic length L_0 . To ensure that acousto-optic interaction occurs in Raman-Nath diffraction region, it is desired to use a smaller L value, causing decrease in diffraction efficiency. A higher central frequency, however, can increase the band width of acousto-optic devices and that of acousto-optic driving circuits. Therefore, the central frequency was chosen to be 30-35 MHz.

4. Traveling Wave State of Acoustic Waves

If reflected waves exist in multiple dimensional acoustic waves, they will interact further with light waves to form multiple additional false modulation of light spots. An acoustic traveling wave device is therefore needed. For this purpose the

reflection surface of acoustic waves in each dimension is polished into a special shape to reduce the reflected wave. Measurement results have shown that this method can ensure the nature of a traveling wave.

The Raman-Nath acoustic-optic modulation spectrum of a traveling acoustic wave is different from that of stationary acoustic waves[8]. In the case of traveling waves, the diffracted light field of each order is $J_{n_m}(V_m)\exp\{i(\omega + n_m\omega_m^*)t\}$, and Doppler frequency shift $n_m\omega_m^*$ occurs in diffraction order n_m . On the other hand, the diffracted light field of each order in the case of a stationary wave is $J_{n_m}(V_m \sin \omega_m^* t)\exp(i\omega t)$. Diffracted light of an odd-numbered order contains frequency component $\omega \pm (2r + 1)\omega_m^*$, and that of even-numbered order contains frequency component $\omega \pm 2r\omega_m^*$ ($r = 0, 1, 2, \dots$), namely diffracted light of every order contains a multiple Doppler frequency shift. The acoustic frequency component of each diffraction order of multiple dimensional acousto-optic devices was measured by a radio frequency spectrometer and the results indicate there was only frequency spectrum component of modulation frequency. F-P scan interferometer was also used to observe the vertical pattern frequency spectrum component and amount of frequency shift of modulation light beam and only vertical pattern translation appeared with use of driving power which shows the device was under pure traveling wave modulation.

5. Utilization of Radiating Apparatus

In multiple acousto-optic devices, many ultrasonic wave signals are added to the acousto-optic medium at the same time and this causes significant medium heating. In addition, the device will be used in the study of space coherent optical double steady-state and a stronger driving power is required to pass the turning point in modulation curve. This may also cause more device heating which will both damage the acousto-optic medium and induce light spot dispersion. Therefore, a radiating

apparatus was designed to ensure continuous device functioning for a long period of time under strong signals.

6. Multiple Acousto-optic Device of Combined Type

Several single dimension acousto-optic devices were arranged in a continuous array and the direction of the device in each dimension can be fine-tuned. Multiple acousto-optic diffraction can be realized because the diffraction angle of each dimension is relatively small and Raman-Nath diffraction is not very dependent on the incident angle of light. The device in each dimension can use a medium of large optimum value, such as lead molybdate or tellurium oxide, to obtain higher diffraction efficiency. This reasoning was proved to be correct by experiment.

E. Conclusion

One-dimensional Bragg or Raman-Nath acousto-optic interaction of single acoustic wave can produce diffracted light of first or multiple order. One-dimensional multiple-frequency acousto-optic interaction is to introduce multiple ultrasonic signals in one direction to produce the corresponding multiple order major diffracted light and intermodulation light. All of these lights, however, are distributed in the same plane of acousto-optic interaction and each diffracted light is separated from another by difference in ultrasonic frequency. Interference among each other occurs easily and limits an increase in number of acoustic waves, hence the amount of diffracted light. In multiple dimensional acousto-optic interaction, independent ultrasonic signals along different directions are introduced to interact with a beam of light waves at the same time producing acousto-optic modulation and deflection along multiple directions and forming multiple order diffracted light in space. Therefore, many pieces of information can be loaded on one beam of light wave, greatly increasing capacity for information

transmission. Multiple acousto-optic devices may be used as space light modulator, multiple channel switch, multiple-use communication light modulator, etc. As an optical functional device of space type, it has great application potential and great scientific significance in such high-tech areas as optical parallel calculation, optical communication, and optical information processing.

DISTRIBUTION LIST

DISTRIBUTION DIRECT TO RECIPIENT

<u>ORGANIZATION</u>	<u>MICROFICHE</u>
B085 DIA/RTS-2FI	1
C509 BALL0C509 BALLISTIC RES LAB	1
C510 R&T LABS/AVEADCOM	1
C513 ARRADCOM	1
C535 AVRADCOM/TSARCOM	1
C539 TRASANA	1
Q592 FSTC	4
Q619 MSIC REDSTONE	1
Q008 NTIC	1
Q043 AFMIC-IS	1
E051 HQ USAF/INET	1
E404 AEDC/DOF	1
E408 AFWL	1
E410 AFDIC/IN	1
E429 SD/IND	1
P005 DOE/ISA/DDI	1
P050 CIA/OCR/ADD/SD	2
1051 AFTT/LDE	1
PO90 NSA/CDB	1
2206 FSL	1

Microfiche Nbr: FTD95C000012
NAIC-ID(RS)T-0397-94