

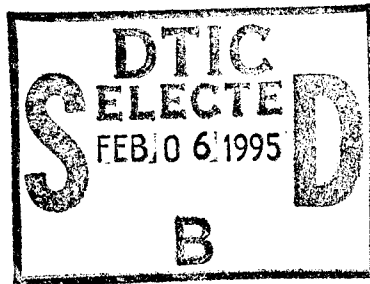

US Army Corps
of Engineers

Construction Engineering
Research Laboratories



USACERL Technical Report FM-94/14
September 1994

The Effects of Construction Automation on Corps of Engineers Quality Assurance Practices

by
Steven J. Brown and Thomas J. Kelly

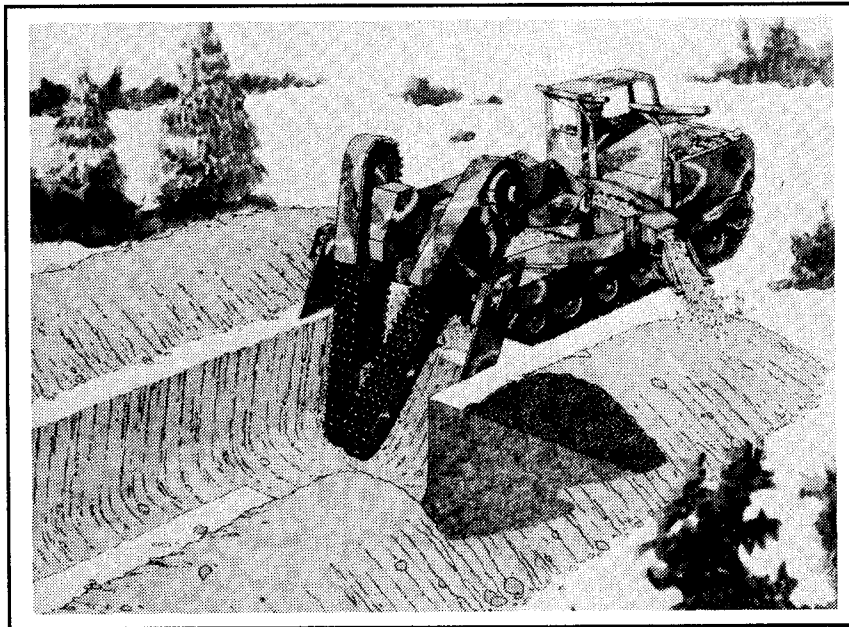

19950201 055

A steady decrease in skilled construction labor has spurred greater construction industry reliance on machine automation. While automation may improve productivity and quality, it may also alter established construction processes to the point of rendering many U.S. Army Corps of Engineers (USACE) quality assurance (QA) practices ineffective.

This report evaluates the potential impact of construction automation on USACE QA practices. Heavy construction techniques, materials, and QA practices are reviewed. The state of construction automation is surveyed and evaluated to reveal technologies that may render current USACE

construction QA techniques ineffective within the next 15 years. The machine automation characteristics that render current QA techniques ineffective are analyzed to suggest new or modified approaches that can verify automated construction quality.

Current industry and research trends suggest that construction automation will have no impact on most USACE QA practices over the next 15 years. However, the automation of trenchless construction may require new QA techniques using ground-penetrating radar and magnetic sensors to verify quality. New QA techniques may also be needed to verify concrete slipforming.

The contents of this report are not to be used for advertising, publication, or promotional purposes. Citation of trade names does not constitute an official endorsement or approval of the use of such commercial products. The findings of this report are not to be construed as an official Department of the Army position, unless so designated by other authorized documents.

DESTROY THIS REPORT WHEN IT IS NO LONGER NEEDED

DO NOT RETURN IT TO THE ORIGINATOR

USER EVALUATION OF REPORT

REFERENCE: USACERL Technical Report FM-94/14, *The Effects of Construction Automation on Corps of Engineers Quality Assurance Practices*

Please take a few minutes to answer the questions below, tear out this sheet, and return it to USACERL. As user of this report, your customer comments will provide USACERL with information essential for improving future reports.

1. Does this report satisfy a need? (Comment on purpose, related project, or other area of interest for which report will be used.)

2. How, specifically, is the report being used? (Information source, design data or procedure, management procedure, source of ideas, etc.)

3. Has the information in this report led to any quantitative savings as far as manhours/contract dollars saved, operating costs avoided, efficiencies achieved, etc.? If so, please elaborate.

4. What is your evaluation of this report in the following areas?

a. Presentation: _____

b. Completeness: _____

c. Easy to Understand: _____

d. Easy to Implement: _____

e. Adequate Reference Material: _____

f. Relates to Area of Interest: _____

g. Did the report meet your expectations? _____

h. Does the report raise unanswered questions? _____

i. General Comments. (Indicate what you think should be changed to make this report and future reports of this type more responsive to your needs, more usable, improve readability, etc.)

5. If you would like to be contacted by the personnel who prepared this report to raise specific questions or discuss the topic, please fill in the following information.

Name: _____

Telephone Number: _____

Organization Address: _____

6. Please mail the completed form to:

Department of the Army
CONSTRUCTION ENGINEERING RESEARCH LABORATORIES
ATTN: CECER-IMT
P.O. Box 9005
Champaign, IL 61826-9005

REPORT DOCUMENTATION PAGE

Form Approved
OMB No. 0704-0188

Public reporting burden for this collection of information is estimated to average 1 hour per response, including the time for reviewing instructions, searching existing data sources, gathering and maintaining the data needed, and completing and reviewing the collection of information. Send comments regarding this burden estimate or any other aspect of this collection of information, including suggestions for reducing this burden, to Washington Headquarters Services, Directorate for Information Operations and Reports, 1215 Jefferson Davis Highway, Suite 1204, Arlington, VA 22202-4302, and to the Office of Management and Budget, Paperwork Reduction Project (0704-0188), Washington, DC 20503.

1. AGENCY USE ONLY (Leave Blank)		2. REPORT DATE September 1994	3. REPORT TYPE AND DATES COVERED Final	
4. TITLE AND SUBTITLE The Effects of Construction Automation on Corps of Engineers Quality Assurance Practices			5. FUNDING NUMBERS 4A162784 AT41 MA-CP2	
6. AUTHOR(S) Steven J. Brown and Thomas J. Kelly				
7. PERFORMING ORGANIZATION NAME(S) AND ADDRESS(ES) U.S. Army Construction Engineering Research Laboratories (USACERL) P.O. Box 9005 Champaign, IL 61826-9005			8. PERFORMING ORGANIZATION REPORT NUMBER FM-94/14	
9. SPONSORING / MONITORING AGENCY NAME(S) AND ADDRESS(ES) Directorate of Military Programs, U.S. Army Corps of Engineers ATTN: CEMP-CD 20 Massachusetts Ave, NW. Washington, D.C. 20314-1000			10. SPONSORING / MONITORING AGENCY REPORT NUMBER	
11. SUPPLEMENTARY NOTES Copies are available from the National Technical Information Service, 5285 Port Royal Road, Springfield, VA 22161.				
12a. DISTRIBUTION / AVAILABILITY STATEMENT Approved for public release; distribution is unlimited.			12b. DISTRIBUTION CODE	
13. ABSTRACT (Maximum 200 words) <p>A steady decrease in skilled construction labor has spurred greater construction industry reliance on machine automation. While automation may improve productivity and quality, it may also alter established construction processes to the point of rendering many U.S. Army Corps of Engineers (USACE) quality assurance (QA) practices ineffective.</p> <p>This report evaluates the potential impact of construction automation on USACE QA practices. Heavy construction techniques, materials, and QA practices are reviewed. The state of construction automation is surveyed and evaluated to reveal technologies that may render current USACE construction QA techniques ineffective within the next 15 years. The machine automation characteristics that render current QA techniques ineffective are analyzed to suggest new or modified approaches that can verify automated construction quality.</p> <p>Current industry and research trends suggest that construction automation will have no impact on most USACE QA practices over the next 15 years. However, the automation of trenchless construction may require new QA techniques using ground-penetrating radar and magnetic sensors to verify quality. New QA techniques may also be needed to verify concrete slipforming.</p>				
14. SUBJECT TERMS quality assurance techniques construction automation U.S. Army Corps of Engineers (USACE)			15. NUMBER OF PAGES 102	16. PRICE CODE
17. SECURITY CLASSIFICATION OF REPORT Unclassified	18. SECURITY CLASSIFICATION OF THIS PAGE Unclassified	19. SECURITY CLASSIFICATION OF ABSTRACT Unclassified	20. LIMITATION OF ABSTRACT SAR	

FOREWORD

This research was performed for the Directorate of Military Programs, Headquarters, U.S. Army Corps of Engineers (HQUSACE) under project 4A162784AT41, "Military Facilities Engineering Technology"; Work Unit MA-CP2, "Quality Assurance for Automated Construction." The HQUSACE technical monitors were Robert Chesi and Richard Carr, CEMP-CD.

This research was performed by the Engineering and Materials Division (FM) of the Infrastructure Laboratory (FL), U.S. Army Construction Engineering Research Laboratories (USACERL). Dr. Paul A. Howdyshell is Chief, CECER-FM, and David Joncich is Acting Chief, CECER-FL. The USACERL technical editor was Gordon L. Cohen, Information Management Office.

LTC David J. Rehbein is Commander and Acting Director, USACERL. Dr. Michael J. O'Connor is Technical Director.

CONTENTS

		Page
	SF298	1
	FOREWORD	2
	LIST OF FIGURES AND TABLES	5
1	INTRODUCTION	9
	Background	
	Objective	
	Approach	
	Scope	
	Mode of Technology Transfer	
2	OVERVIEW OF MATERIALS, CONSTRUCTION TECHNIQUES, AND QUALITY ASSURANCE PRACTICES	11
	Material Properties	
	Materials Used in Sitework	
	Materials Used in Concrete Construction	
	Materials Used in Masonry Construction	
	Materials Used in Steel Construction	
	Overview of USACE Construction Techniques	
	Sitework Techniques	
	Concrete Construction Techniques	
	Masonry Construction Techniques	
	Steel Construction Techniques	
	Overview of USACE QA Practices	
	Sitework QA Methods	
	QA for Concrete Construction	
	QA for Masonry Construction	
	QA for Steel Construction	
3	THE STATE OF CONSTRUCTION AUTOMATION TECHNOLOGY	34
	Technology Transfer of Sitework Construction Automation	
	Technology Transfer of Concrete, Masonry, and Steel Construction Automation	
	Reasons for Excessive U.S. Technology Transfer Duration	
	Survey of Automation Technologies	
	Sitework Automation	
	Concrete Construction Automation	
	Masonry Construction Automation	
	Steel Construction Automation	
	Comprehensive Automated Building Systems	
	Construction Automation Trends	
	Definition of "Trend"	
	Trends in Sitework Automation	
	Concrete Construction Automation Trends	
	Masonry Construction Automation Trends	
	Steel Construction Automation Trends	
	Comprehensive Automated Building System Trends	

Accession For	
NTIS GRA&I	<input checked="" type="checkbox"/>
DTIC TAB	<input type="checkbox"/>
Unannounced	<input type="checkbox"/>
Justification	
By _____	
Distribution _____	
Availability Codes	
Dist	Avail and/or Special
A-1	

CONTENTS (Cont'd)

	Page
4	LIKELY EFFECTS OF AUTOMATION ON USACE QUALITY ASSURANCE 57
	Changes in Materials and Processes vs Changes in Tools
	Automation Effects on Sitework QA
	Automation Effects on Concrete Construction QA
	Automation Effects on Masonry Construction QA
	Automation Effects on Steel Construction QA
	QA Implications for Comprehensive Automated Building Systems
5	SUMMARY AND RECOMMENDATIONS 60
	Summary
	Recommendations

REFERENCES

APPENDIX A: Sitework Construction Automation Technologies	67
APPENDIX B: Concrete Construction Automation Technologies	78
APPENDIX C: Masonry Construction Automation Technologies	88
APPENDIX D: Steel Construction Automation Technologies	90
APPENDIX E: Comprehensive Automated Building Systems	94
APPENDIX F: Possible NDE Technologies for Construction Automation QA	96

DISTRIBUTION

FIGURES

1	Unified Soil Classification System	13
2	Split-spoon Sampler	16
3	Clearing and Grubbing Pattern	17
4	Offset Lines and Stakes	18
5	Batter Boards	19
6	Dewatering	20
7	Lagging Systems	21
8	Slurry Wall	22
9	Bracing Systems	23
A1	Global Positioning System	67
A2	Soft Excavator	68
A3	Torçe	69
A4	RRR Excavator	70
A5	Rock Drill	70
A6	CASTEC System	71
A7	SSS-G	72
A8	High-Speed Excavator	73
A9	Overburden Excavator	73
A10	Automated Shield Tunneling	74
A11	Drilling Jumbo	75
A12	Mini Mucker	76
A13	Laser Grading	77
A14	Automated Compaction	77
B1	Rebar-Arranging Robot	78
B2	Slipforming	79

FIGURES (Cont'd)

Number		Page
B3	Integrated Construction System	80
B4	Horizontal Concrete Distributor	81
B5	Concrete Spraying Robot	82
B6	Shotcrete Robot	82
B7	Meyco Spraying Robot (Meynadier)	83
B8	Slide Press Lining Robot	83
B9	Automatic Exterior Vibrator/Tamper	84
B10	Screed Robo	85
B11	Concrete-Screeding Robot	86
B12	Surf Robo	86
B13	Multiple-Task Floor Robot	87
C1	Masonry Robot Complex	88
C2	Blockbot	89
D1	Mighty Jack	90
D2	Mighty Shackle Ace	90
D3	ACES	91
D4	ATLSS Connection	92
D5	Onsite Welding System	93
E1	SMART System	94
E2	Automatic Building Machine (ABM)	95

TABLES

Number		Page
1	Current State of Sitework Automation Research, Development, and Technology	38

TABLES (Cont'd)

Number		Page
2	Current State of Concrete Automation Research, Development, and Technology	40
3	Current State of Masonry Automation Research, Development, and Technology	47
4	Current State of Steel Automation Research, Development, and Technology	49
5	Current State of Comprehensive Automated Building Systems	50
6	Summary of Current Construction Automation Trends	52

THE EFFECTS OF CONSTRUCTION AUTOMATION ON CORPS OF ENGINEERS QUALITY ASSURANCE PRACTICES

1 INTRODUCTION

Background

Over the past few decades the pool of skilled construction laborers has been decreasing in many of the leading industrialized nations, including Japan, France, Germany, and, to some extent, the United States. The result of this decrease has been a steady rise in the cost of skilled construction labor. The affected nations have responded by developing machines to automate key construction processes, both to help stabilize labor costs and assist the laborer in the field. Advances in sensors, automatic controls, and computer technology have made construction automation more capable than ever before. Current research and development (R&D) in university and corporate laboratories worldwide will eventually produce machines to replace human labor on numerous construction tasks.

As more construction tasks are automated and new machines are developed, construction processes may significantly change. Any change in a construction process has the potential to reduce the effectiveness of established construction quality assurance (QA) practices. For all its potential benefits, then, construction automation may actually pose a dilemma for the U.S. Army Corps of Engineers (USACE), which is responsible for Army construction QA processes and final project quality. Since the late 1960s, USACE has fulfilled its QA mission with a Quality Assurance/Contractor Quality Control (QA/CQC) system, through which a contractor's quality control techniques and product quality are monitored—from initial project discussions through use or occupancy. Because construction techniques used on USACE projects had not begun to change substantially until only recently, there has been little need to change established USACE QA techniques. With the emergence of automated construction, however, USACE QA techniques may need to change. To continue effectively fulfilling its construction quality mission for the Army, USACE must understand the potential effects of construction automation trends on established QA practices, and update any practices that may be made obsolete by the advance of automation.

Objective

The objective of this study is to determine how the automation of construction will affect USACE QA practices over the next 15 years, and to identify which practices are most likely to need updating as a result of construction automation.

Approach

This research began with a review of all four volumes of Engineer Pamphlet (EP) 415-1-261, *Construction Inspector's Guide*, the principal USACE guidance document on construction inspection. General categories of construction to be investigated were chosen to correspond with the organization of that document.

An initial review of the literature was conducted to identify all categories of construction in which substantial progress in automation has been made or is expected. Four construction categories were identified:

- Sitework
- Concrete
- Masonry
- Steel.

A detailed literature review was then conducted in the four construction categories listed above. Current materials and techniques used in each category were investigated, and USACE QA practices were reviewed. The current availability of automated systems in each category was examined, and related worldwide research activities were identified. Historical data about technology transfer in construction were also studied.

The authors analyzed all of the information gathered to make inferences about construction automation trends and their likely impacts on U.S. construction sites within the next 15 years. The analysis focused on two subject areas: changes in construction tools and changes in construction processes. Analyzing these two categories of change in conjunction with findings on the typical amount of time required for technology transfer enabled the authors to project the impact of the automation trends on USACE QA tools and techniques. On the basis of these projections, the authors identified USACE QA practices that may require updating, and made general suggestions for updating them.

Scope

In this report the authors define *automation* “as the use of machines to improve the effectiveness of construction methods or processes.” The authors define *machine* as “a device that interacts with and changes its physical environment.” Therefore, automation of construction information management is not addressed in this study unless it is part of a machine-based system.

Mode of Technology Transfer

The findings of this study may impact volumes 1, 2, and 3 of EP 415-1-261.

2 OVERVIEW OF MATERIALS, CONSTRUCTION TECHNIQUES, AND QUALITY ASSURANCE PRACTICES

Over the past few decades, technological advances have refined—but not revolutionized—traditional sitework, concrete, masonry, and steel construction techniques. Because these technologies have not advanced radically, established USACE QA practices have remained largely unchanged. However, the widespread introduction of advanced construction automation may soon require significant changes in USACE construction QA techniques. To continue effectively fulfilling its construction QA mission, USACE must identify construction automation trends that are likely to render current QA techniques obsolete within the next 15 years and develop new techniques to replace them.

In the broadest terms, USACE QA for sitework, concrete, masonry, and steel construction verifies the quality of (1) the materials and (2) the processes employed to put the materials together.

Material Properties

Materials Used in Sitework

Sitework construction involves several distinct stages and tasks: soils testing, site layout and quantity survey, clearing and grubbing, and earthworks. Earthworks includes trenching, tunneling, and dredging. The primary material in sitework construction is soil. The secondary materials are concrete and steel, which are used for soil retention systems (and are covered later in this chapter).

Soil is made of weathered rock, decayed vegetation, water and air. Soil particles are the product of rock weathering and vegetation decay. Over a long time, soil particles may consolidate under the weight of overlying material and become rock. This rock, in turn, can be weathered and become soil particles again. This is why the distinction between soil and rock can be quite ambiguous (Liu and Evett 1981).

Soils can be separated into three categories: cohesionless, cohesive, and organic. Cohesionless soils are composed of particles that do not stick together; examples include gravel, sand, and silt. Particle sizes for gravel are 5 mm or larger; for sand, 0.1 to 5 mm; and for silt, 0.005 to 0.1 mm. Cohesive soils are made of particles that stick together. Clay is a common type of cohesive soil, with a grain size less than five 0.005 mm. Organic soil is not granular, but is typically spongy, crumbly, and compressive. Its made mostly of decayed plant and animal material.

Engineering properties for cohesionless soils depend on grain-size distribution, which is determined by separating the soil particles. This is accomplished through a sieve analysis, in which soil is poured through stacked sifting meshes of different sizes to separate particles by category. The largest particles stay at the top of the sieve while the smallest settle to the bottom. The amounts of each size particle are weighed to determine grain-size distribution.

Sieve analysis cannot determine the engineering properties of cohesive and organic soils because cohesive soil grains are too small and organic soil is not granular. For these soils, grain-size distribution may be estimated using the hydrometer method, in which observing the settling velocities of particles in a soil-water mixture are observed. Another method uses tests to determine Atterberg limits, which indicate the moisture-content range in which a soil behaves as a liquid, semisolid, and solid. The various soil-moisture capabilities, coupled with environmental factors at the soil's location, are used to design the substructure.

Systems have been developed so soil can be designated without listing all of its characteristics. An example of this, shown in Figure 1, is the Unified Soil Classification System (Allen 1985, p 17), which is used by USACE. This system uses letter symbols to classify soils. Other systems include the American Association of State Highway and Transportation Officials (AASHTO) system and the Federal Aviation Administration (FAA) system.

Soil compressive strength is affected by the compositional ratio of solid material (weathered rock or decayed vegetation), water, and gaseous material (usually air). Compressive strength is greater when a soil has a smaller gas- or liquid-to-solid ratio. In other words, the greater a soil's density, the greater its compressive strength. This ratio plays an important role with cohesive soils, because moisture greatly affects particle interaction. This is a concern because, when a cohesive soil containing an excessive amount of water is loaded, moisture release will be delayed. This could cause a building to settle unexpectedly soon after its completion. A recent example of this is the Kansai Airport in Japan (Normile, March 1991).

Soil shear strength is a product of particle internal friction and cohesion. Sand, which has almost no cohesion, gains its strength from internal friction. Any moisture in sand during loading will be pressed out, resulting in stable shear strength throughout the structure's lifetime. Cohesive clay has the greatest amount of cohesion, but almost no internal friction—especially if it is saturated with water. (Clay in its natural state is close to moisture saturation.) After loading, water is pressed out, and the soil voids shrink, resulting in internal friction resistance and greater soil shear strength. This is why structures on cohesive clay are designed as if the clay will have no frictional resistance. The increase of the soil's frictional resistance after being loaded is used as a safety factor.

Soil compactability is affected by moisture content and soil gradation. Moisture within soil reduces the internal friction and eases compaction. However, moisture saturation makes compaction difficult because the soil will plastically deform around the compacting device. Therefore, an optimum moisture content is sought, in which the water content causes the soil's air permeability to be zero. The relationship between air permeability (K_a) and water content can be determined in the laboratory through the results of a standard proctor test (AASHTO T-99) or a modified test (AASHTO T-180), which are evaluated to find the optimum moisture content on moisture-density curves. Field tests to find moisture content and density are the sand cone test, the balloon test, and nuclear tests, which are discussed later in this chapter under "Overview of USACE Construction Technologies."

Compactibility is also aided when the soil is well graded. Grading fills voids that would occur in a gap-graded soil (soil of only one particle size). The increase in density increases the soil's strength. The characteristics of soil require that its compaction occur in lifts, or layers, not the total depth of the fill (Wood 1977).

The two greatest factors influencing soil strength are density and moisture content. Soil density is also affected by the soil particle gradation and moisture content.

Materials Used in Concrete Construction

Basic concrete components include cement, coarse and fine aggregates, water, and various admixtures. Steel reinforcing bars (rebars) or welded wire fabric are usually also used. The quality of these ingredients, individually and as a whole, affects concrete strength and durability.

Cement, composed mainly of lime, silica alumina, and iron, can be made in various strengths. The finer the material is ground, the higher is the heat produced by the chemical reaction (hydration) between it and water, which makes the concrete stronger. Cement contamination must be prevented for adequate

		Group Symbols	Typical Names	
Fine-grained Soils	Coarse-grained Soils	Gravels	Clean Gravels	GW Well-graded gravels, gravel-sand mixtures, little or no fines
			Gravels with Fines	GP Poorly graded gravels, gravel-sand mixtures, little or no fines
		Sands	Gravels with Fines	GM Silty gravels, poorly graded gravel-sand-silt mixtures
			Clean Sands	GC Clayey gravels, poorly graded gravel-sand-clay mixtures
			Clean Sands	SW Well-graded sands, gravelly sands, little or no fines
			Sands with Fines	SP Poorly graded sands, gravelly sands, little or no fines
	Sils and Clays	(Liquid limit greater than 50)	ML	Silty sands, poorly graded sand-silt mixtures
			CL	Clayey sands, poorly graded sand-clay mixtures
			SC	Clayey sands, poorly graded sand-clay mixtures
	(Liquid limit less than 50)	ML	Inorganic silts and very fine sands, rock flour, silty or clayey fine sands with plasticity	
CL		Inorganic clays of low to medium plasticity, gravelly clays, sandy clays, silty clays, lean clays		
OL		Organic silts and organic silt-clays of low plasticity		
Highly Organic Soils	(Liquid limit less than 50)	MH	Inorganic silts, micaceous or diatomaceous fine sandy or silty soils, elastic silts	
		CH	Inorganic clays of high plasticity, fat clays	
		OH	Organic clays of medium to high plasticity	
Pt	Peat and other highly organic soils			

Source: Allen, Edward, *Fundamentals of Building Construction Materials and Methods*, ©1985, John Wiley & Sons, Inc. Reprinted by permission.

Figure 1. Unified Soil Classification System.

results. For example, any moisture infiltration of the cement will cause hydration to start, producing solid chunks in the cement.

Cement types are classified by ASTM-C150, *Standard Specification for Portland Cement*. Type I cement is used for most construction purposes, and is termed “normal.” Types II and V are used when concrete will be in contact with substances containing a high level of sulfates. Type III cement is used for cold weather work, precasting structural elements, or when a reduced curing period is desired. In dam construction and other massive concrete projects, Type IV cement is used to lower the heat of hydration so the concrete does not crack excessively while curing.

By volume, aggregate is the main ingredient in concrete. For concrete to achieve optimum strength, aggregates must be strong, free of chemical contamination or clay, properly graded for size, and have high resistance (impermeability) to chemicals and abrasion. The water used should be free of impurities such as salt, which might have harmful effects on the concrete and reinforcement materials. If the water or aggregates are not clean, the bond between the cement and the aggregate will be reduced, lowering the concrete’s overall strength. This will reduce the shear and compression capacities of the concrete. Also, if the water or aggregates are contaminated with salt, the reinforcing steel will corrode at an accelerated rate.

There are four primary admixtures used with concrete: air entrainers, accelerators, retarders, and water reducers. As with cement, all admixtures must be protected from contamination.

Air entrainers help protect against freeze-thaw cycle damage by producing microscopic air voids, which allow the concrete to expand and contract without causing internal pressures. They also increase workability of the concrete by producing a more fluid mixture. Accelerators, which quicken the concrete’s curing process, are used in cold weather placement and in highrise buildings, where loads are applied as soon as possible. During hot weather, retarders are used to lengthen setting time, thereby reducing the possibility of cold joints, in which the concrete sets before the next lift is placed. Retarders also increase concrete workability and allow more time for proper consolidation and finishing of the concrete surface. Water reducers are used to allow a reduction in the water-to-cement (w/c) ratio without losing the necessary workability.

Steel reinforcement is required to increase the tensile strength of concrete, because its tensile strength is less than 10 percent of its compressive strength. Generally, the higher the carbon content of steel, the stronger and less ductile it is. Because of the tradeoff of strength for ductility, steel reinforcing requires special precautions for welding.

Not only does the quality of concrete’s ingredients affect its strength and durability, but also the manner in which it is proportioned, combined or batched, mixed with water, placed, and cured. The two important qualities for finished concrete are strength and durability. Strength is related to the w/c ratio: generally, the lower the w/c ratio, the stronger the concrete. However, this also makes it less workable.

Concrete durability is primarily enhanced by the use of air entrainers. They form microscopic voids that expand and contract with temperature fluctuations. The voids alleviate extreme internal stresses that may develop. Unlike strength, durability cannot be easily or accurately measured with available technology.

Materials Used in Masonry Construction

The components of masonry construction are the masonry unit, mortar, and steel reinforcing. Masonry units are quite varied and have different properties that affect the overall strength and durability

of the masonry structure. The most common masonry units are brick, terra cotta, stone, and concrete masonry units (CMUs).

The performance of brick and terra cotta depends on the type of clay, molding method, and firing process. For example, special clays with refractory qualities are used for bricks in extreme-heat situations, such as fireplaces. Being resistant to thermal changes, the bricks do not deteriorate and jeopardize their structural integrity. During brick manufacturing, higher firing temperatures produce greater brick shrinkage. This results in smaller air voids, which decrease permeability and increase compressive strength, but reduce flexural durability.

Stone strength and durability depend on the type of rock. Sedimentary rock such as limestone and sandstone results from the compaction of sediments, and is not strong or durable. Igneous rock such as granite is a mosaic of mineral crystals deposited in a molten state, and is much stronger and more durable than sedimentary rock. The strongest type of stone is metamorphic rock such as slate or marble, which is the recrystallized form of sedimentary or igneous rock transformed by heat and pressure.

CMUs are units of low-slump concrete that have been form-vibrated and steam-cured under high pressure. They achieve their strength and durability through control of the w/c ratio and air entrainment.

The two materials that bind masonry units together and strengthen masonry structures are mortar and reinforcing steel. Mortar is composed of Portland cement, hydrated lime, fine aggregate (sand), and water. To enhance troweling workability, lime is added to the Portland cement mixture. The water must be free of impurities that may adversely affect the mortar. Prepackaged masonry cements are also widely used as mortar. In masonry construction, steel reinforcing is placed horizontally between two wythes (vertical layers or walls), to provide lateral stability and increase the wall's load-bearing capacity and resistance to cracking.

Materials Used in Steel Construction

Steel construction uses one material: steel. Structural steel contains less than 0.3 percent carbon. This is quite different from typical A615 reinforcing steel—made from steel left over from the structural steelmaking process—which can, by code, contain 0.75 percent carbon content or greater. Different from reinforcing steel, the strength of which is derived only from its carbon content, structural steel gains strength and other attributes through the addition of metallic elements during the steelmaking process. Manganese gives it abrasion— and impact— resistance. Molybdenum and vanadium enhance its strength. Nickel and chromium increase stiffness and toughness.

In welds of large steel members, the welding electrode must not be composed of steel stronger than the base steel being welded. Also, the weld must be properly designed. A highly restrained joint will not allow enough expansion and contraction of the members being welded, resulting in a lamellar tear or underbead crack that may cause immediate or future failure of the connection. Although this problem may not seem to be a major concern, it has happened during construction of some of the most renowned buildings in the world, such as the Sears Tower in Chicago.

Overview of USACE Construction Techniques

Sitework Techniques

Standard sitework construction techniques have evolved to ensure finished product quality. An overview of typical sitework construction techniques is presented. The techniques are presented in the

order in which they typically occur on the site. Typical sitework construction techniques include soils testing, clearing and grubbing, site layout and survey, and earthwork. Earthwork construction includes topsoil stripping, rough and finish excavation, and rough and final grading. The related earthwork techniques of tunneling and dredging are also discussed.

Soils Testing. Generally, soil conditions are identified before designing a structure for a specific site. Testing involves digging test pits, driving sounding rods, or drilling. Test pits are used when the substructure does not extend farther than 8 ft below grade. This technique allows one to observe the soil strata (layers), take soil samples, and possibly determine the water table depth. A load test of the pit bottom can be performed to determine if the soil will be able to support the imposed load of the structure without excessive settlement.

If the substructure extends farther than 8 ft below grade, a standard penetration test can be conducted. Driven rods can indicate the soil's bearing capacity by the number of blows a standard driving hammer (140 lb falling 30 in.) required to advance the rod into the soil by a specified amount—typically 18 in. The soil's bearing capacity is designated by the N-value, which represents the number of blows required to penetrate the last foot of soil. This technique uses a "split-spoon" sampler (Figure 2). A split-spoon sampler is about 2 in. in diameter, 18 to 24 in. long, and is longitudinally split so the soil within the tube can be removed for laboratory analysis. This technique can also help locate bedrock. Also, drilling is used to extend soil exploration deep into the ground, to obtain information on the dimensions and locations of soil strata and the water table depth, as well as laboratory-quality soil samples for testing (Allen 1985).

Findings of the penetration test or drilling test are used to produce a soil-boring log to describe the soil strata, both in written and graphic form. In the laboratory, the grain-size distribution is determined by sieve analysis or the hydrometer method. Also, the lab determines the moisture content ranges in which the soil acts as a liquid, semisolid, and solid. A standard Proctor (AASHTO-T99) or Modified Test (AASHTO-180) is performed to find the soil's water content. Tests are performed to find both the soil's permeability and its shrinkage when dried. The soil's compression and shear strengths are measured by performing an unconfined compression test, a vane test, a direct-shear test, or a triaxial compression test. A consolidometer is used to calculate the likely rate and magnitude of foundation settlement. This information is used to design the substructure (Liu and Evett 1981).

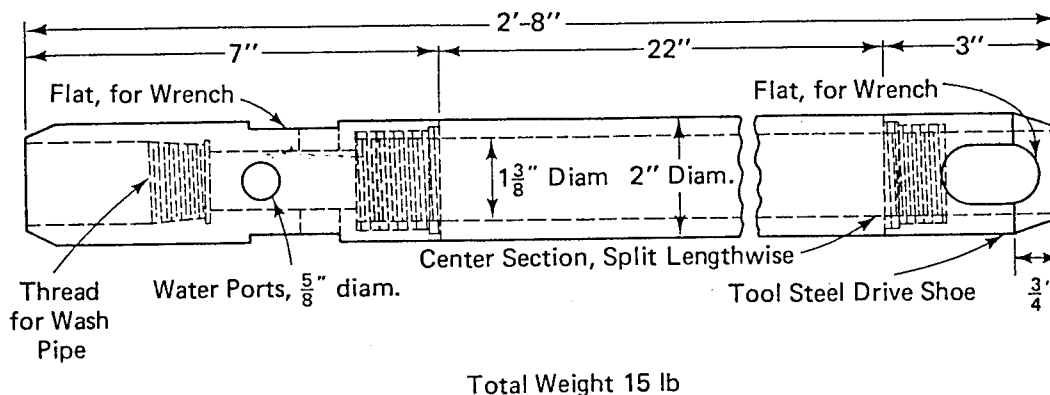

Source: Liu, Cheng, and Jack B. Evett, *Soils and Foundations*, ©1981, Prentice-Hall, Inc. Reprinted by permission.

Figure 2. Split-spoon Sampler.

Clearing and Grubbing. After soil tests are performed, the site is cleared of all trees, shrubs, vines, surface boulders, underbrush, roots, etc., so excavation may begin (Figure 3). This process includes swamping, felling, decking, logging, and grubbing.

Swamping begins with marking and possibly moving utilities, such as power lines, that may be in the way. Then all undesired underbrush, tall grass, small trees, vines, etc are removed. One technique for this test that does not require a bulldozer is called chaining. Chaining involves two large tractors dragging a chain between them, which pulls over or uproots vegetation in the chain's path. The chain typically weighs 60 lb per foot, with a link size of 2.5 in., and is sometimes weighed down by a 4-ft steel ball. The removed material is either hauled offsite or moved out of the way onsite, where it will later be burned, mulched and buried, or hauled elsewhere.

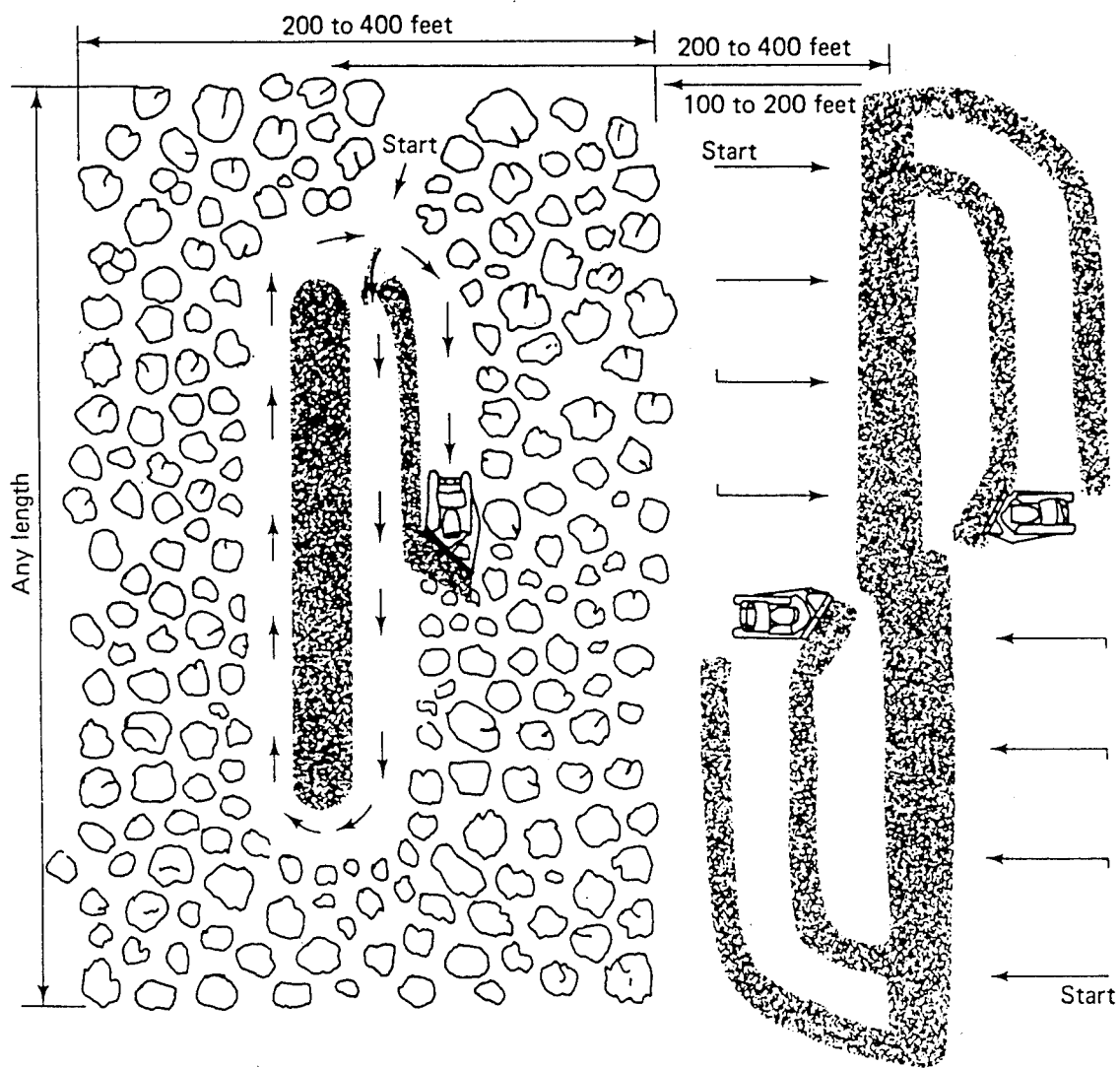

Source: Wood, Stuart, Jr., *Heavy Construction* (Prentice-Hall, Inc., 1977), © Caterpillar, Inc. Reprinted by permission.

Figure 3. Clearing and Grubbing Pattern.

Felling operations usually begin after swamping is complete. They include cutting or knocking down any trees in the future construction area. Tree-climbing equipment, topping rigs, axes, crosscut saws, bulldozers, winches, etc. are required. These procedures require careful safety precautions in hazardous settings, such as slopes, slippery terrain, rock, or outcrops. If the felled trees are in good condition, they are marked to be sold. The rest are cut into manageable sizes, stacked, hauled, and dumped. Then grubbing is performed, which involves removing the tree stumps and matted roots, filling the holes, and compacting the fill. After grubbing is complete, the stumps and roots are stacked, hauled and dumped, burned, or mulched and buried.

Site Layout and Survey. First, a construction benchmark system is developed, based on existing survey marks, street lines or curbs, buildings, etc. Any benchmark that will have to be removed must be referenced from offset lines or stakes (Figure 4). The benchmark system will be the basis for surveying and laying out the site. During surveying and excavation layout, the site layout will be used for horizontal and vertical reference. Consequently, site layout is clearly marked and protected at all times, and a complete record is kept so its alignment can be checked and corrected at any time.

The site layout is developed after the benchmark control system is in place. A baseline is established through the center of the structure's footprint marked by stakes or monuments, both inside and outside the construction area. The outside marks are made in case something happens to the marks within the site. Often the primary baseline is disturbed, so a secondary baseline is located off the building's face. If two axes govern the construction, as in the case of a highway underpass or overpass, two secondary baselines are also established.

Elevation control is also very important. Many fixed markers will be set and labeled with their correct elevation. Others will be placed and labeled where they are not likely to be disturbed. As was done for the baseline markers, elevation stakes will be located outside the construction site. During sitework construction, a periodic level check of the fixed markers outside the construction area is performed. This verifies that the markers have not settled or been disturbed by frost, slides, vandals, or heavy equipment.

Relatively simple construction can use a site control system of batter boards (Figure 5). Batter boards are temporary timber frames driven into the ground offset from a corner hub, to vertically and horizontally mark building corners, culvert faces, drainage pipe ditches, etc. (Barry 1973). Following the site layout, a quantity survey and excavation layout are performed.

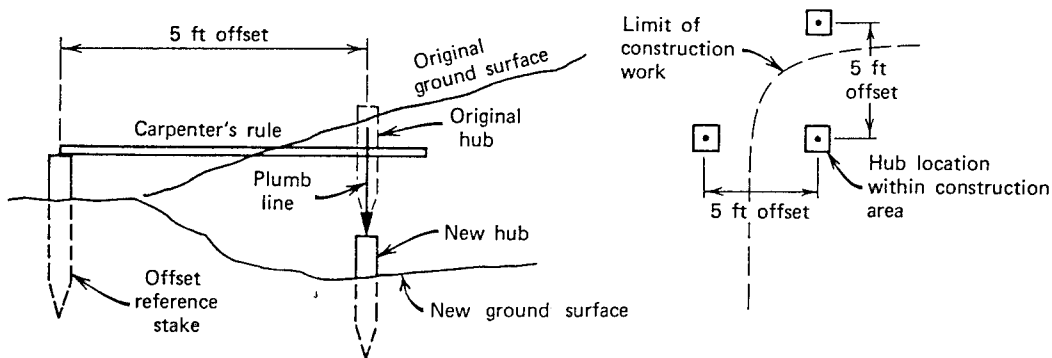

Source: Barry, Austin B., *Construction Measurements*, © 1973, John Wiley & Sons, Inc. Reprinted by permission.

Figure 4. Offset Lines and Stakes.

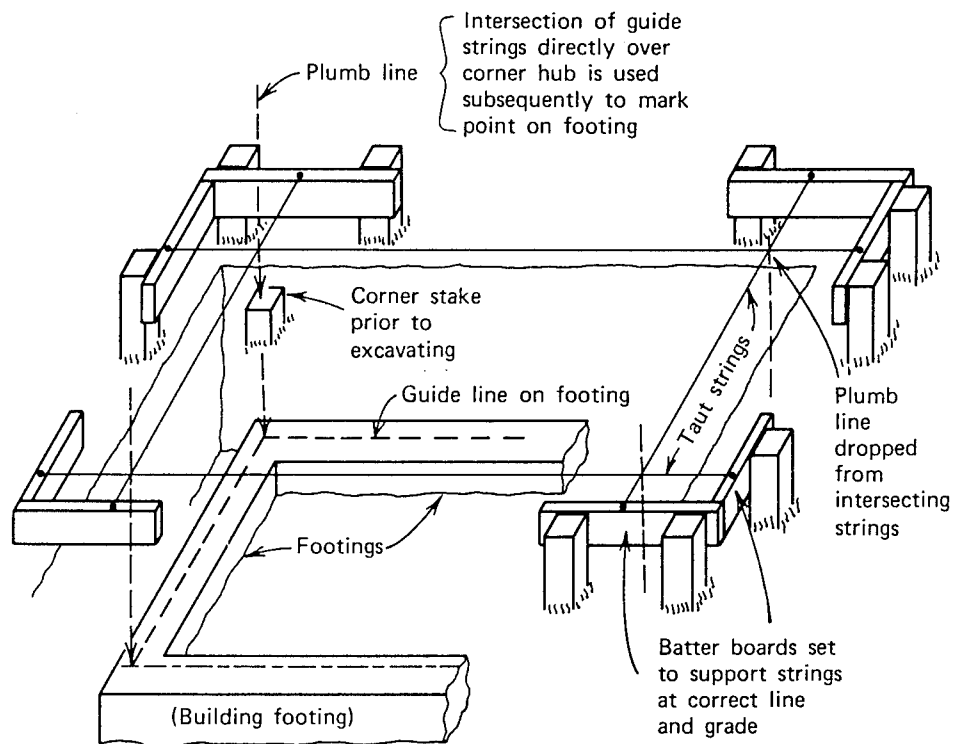

Source: Barry, Austin B., *Construction Measurements*, © 1973, John Wiley & Sons, Inc. Reprinted by permission.

Figure 5. Batter Boards.

The site layout and survey process is very laborious and time consuming, considering that it does not directly result in a tangible product. A technology that could reduce the labor-intensiveness of this process would save a great deal of time and human effort.

Earthwork. Earthwork operations include topsoil stripping and stockpiling, rough and finish excavation, and rough and final grading. Earthwork construction techniques are more an art than a science, and tend to be a “seat-of-the-pants” field implementation of the site plan (Tatum and Funke, March 1988). Earthwork construction starts with the stripping and stockpiling of the site’s topsoil. This is done with a bulldozer, using either blades (during short-haul operations) or scrapers (for large quantities or long hauls).

Excavation is performed after completion of stripping and stockpiling the topsoil. It begins with ensuring correct placement and alignment of the benchmarks and the baselines. Next, the excavation contractor uses the USACE-specified benchmarks and baselines to develop the rough-excavation layout. During the excavation process, the excavation layout is periodically checked by referring to the horizontal and vertical controls of the site layout. Horizontal checks are made with a transit, and vertical checks are made with a level and rod.

There are seven kinds of rough excavation:

1. Bulk pit excavating, which consists of digging a wide, deep area and hauling the soil offsite. This procedure is used for sites with limited access, such as the ones in the inner city.

2. Bulk wide-area excavating, which involves wide, shallow digging. This procedure is used for projects with easy access sites, such as a highway overpass.

3. Loose bulk excavating, which involves moving soil a short distance—moving earth to shape a lake embankment, for example.

4. Limited-area vertical excavation, which lifts soil from a pit with vertical sides, such as a building's basement.

5. Trenching, which involves long, narrow excavations for underground structures such as pipes and conduits.

6. Tunnel excavation, which involves digging and removing earth from under ground.

7. Dredging, which removes silt and other material from under water to deepen river channels and harbors. Tunneling and dredging are special categories of excavation, and are discussed separately later in this chapter.

The rough excavation process includes loosening the soil through blasting (rock), breaking, scarifying (shallow), and ripping (deep). The excavated earth is either stockpiled and used later as backfill, or hauled offsite if there is no room (Lux et al. 1982).

When construction is carried lower than the water table, water flows from the soil into the excavation, and the site must be dewatered. Dewatering is done by pumping water from the surrounding soil to depress the water table below the excavation level, or by erecting a watertight barrier around the excavation (Figure 6). Depression of the water table is usually done by well points, which are vertical pieces of pipe with screened bottom openings, positioned at the desired water level. These pipes carry the unwanted water to horizontal header pipes, and then to the holding areas. Lowering the water table can affect neighboring buildings: it may cause soil to settle under their foundations or expose wooden piles—resulting in their decay. A watertight barrier is sometimes used as an alternative to lowering the water table. Slurry walls (discussed below) develop the best watertight barrier.

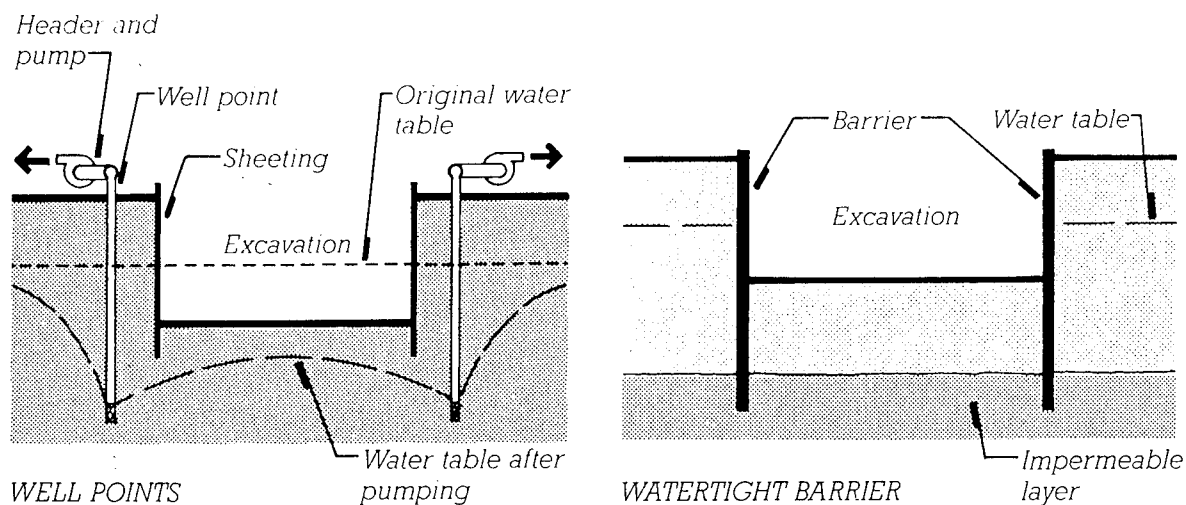

Source: Allen, Edward, *Fundamentals of Building Construction Materials and Methods*, ©1985, John Wiley & Sons, Inc. Reprinted by permission.

Figure 6. Dewatering.

After initial excavation, finish excavation provides soil trimming, shaping, and compaction. This process involves earth retention, cleaning and washing, and grading. Earth retention either involves soil sloping or benching at a correct angle, either to prevent collapse or provide a soil-retention system. The two most common systems used to support a steep excavation embankment are sheeting and bracing. Sheeting comes in many forms, depending on what the soil quality requires. Typical examples are soldier beams and lagging (heavy wood planks), sheet piling, and slurry walls.

Soldier beams and lagging use wide flange sections as soldier beams, which are driven into the ground at intervals the same length as the lagging. As excavation progresses, the lagging planks are added (Figure 7). The soldier beams and lagging are taken down for reuse after the construction is finished.

Sheet piling involves driving wood, steel, or precast concrete planks into the ground. These planks interlock to form a unified wall. As the excavation progresses, the wall is tied back into the soil with steel ties, and braced with steel walers or horizontal braces. Although the wood planking may be removed after the substructure is complete, the steel and concrete planks are usually left in place.

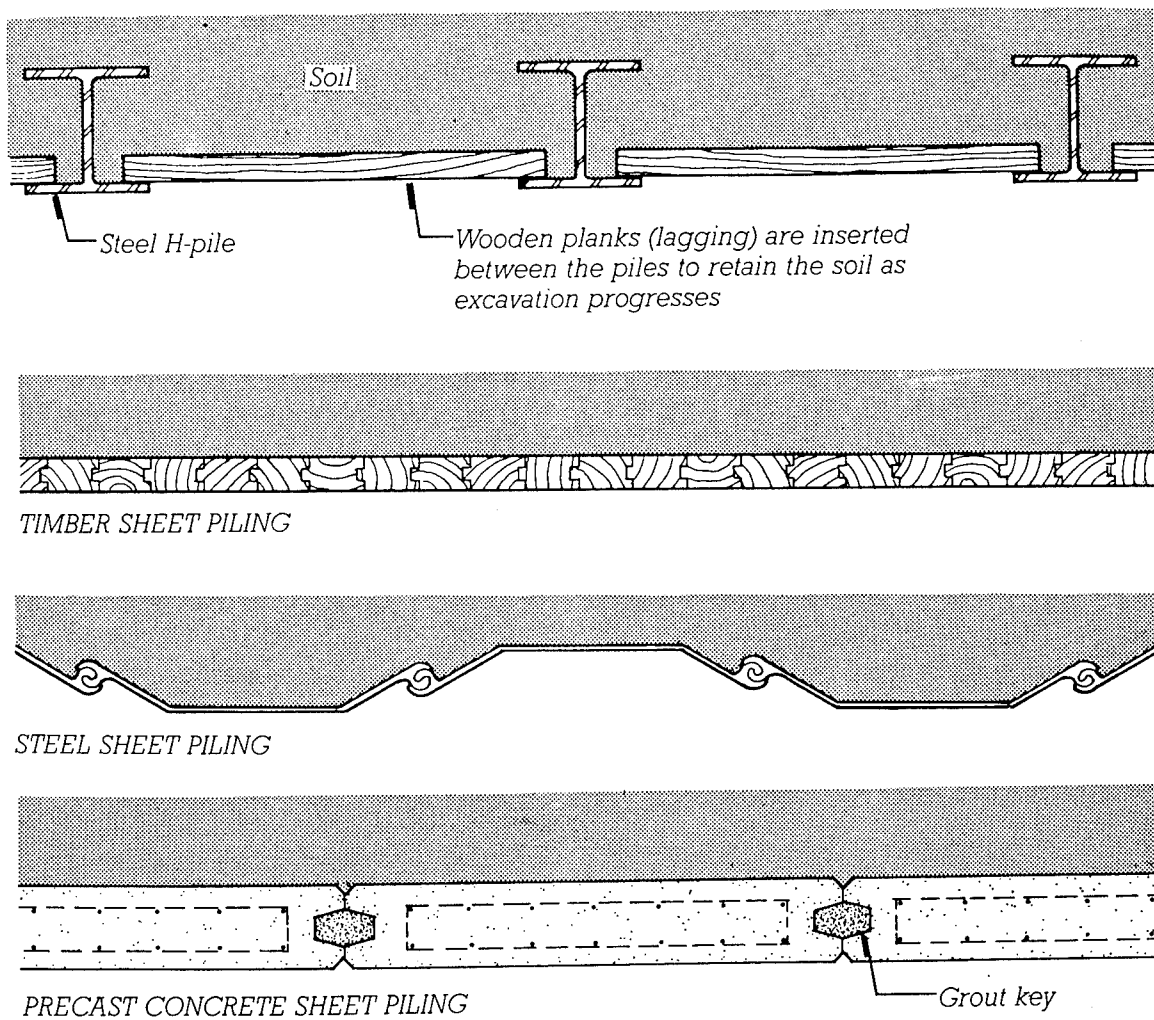

Source: Allen, Edward, *Fundamentals of Building Construction Materials*, ©1985, John Wiley & Sons, Inc. Reprinted by permission.

Figure 7. Lagging Systems.

Slurry walls are used when a stronger, more impenetrable wall is needed, or when the wall may become a foundation wall of the building (Figure 8). First, the wall location is laid out, and concrete guide walls are placed. These walls guide the excavation device, usually a special narrow clamshell bucket mounted on a crane. A trench is dug, and a slurry of bentonite clay and water is pumped into prevent the trench from collapsing. After the trench is excavated, steel reinforcing cages are placed in the trench. Then a steel tube (tremie) is guided to the trench bottom, and concrete is placed while the slurry is pumped out into storage tanks. During excavation the wall is drilled through and tied back into the soil with steel ties.

In addition to sitecast slurry walls, precast, pretensioned slurry walls can also be used. Precast slurry walls, coated on one side with a nonsticking release compound, use Portland cement in the slurry, so the slurry hardens. The hardened slurry locks the tongue and groove units together. As excavation progresses, the slurry falls away from the inward-facing side, which is the coated side. The result is a clean, precast concrete finish. Also, as excavation progresses, the wall is drilled through and tied back into the soil with steel ties (Allen 1985).

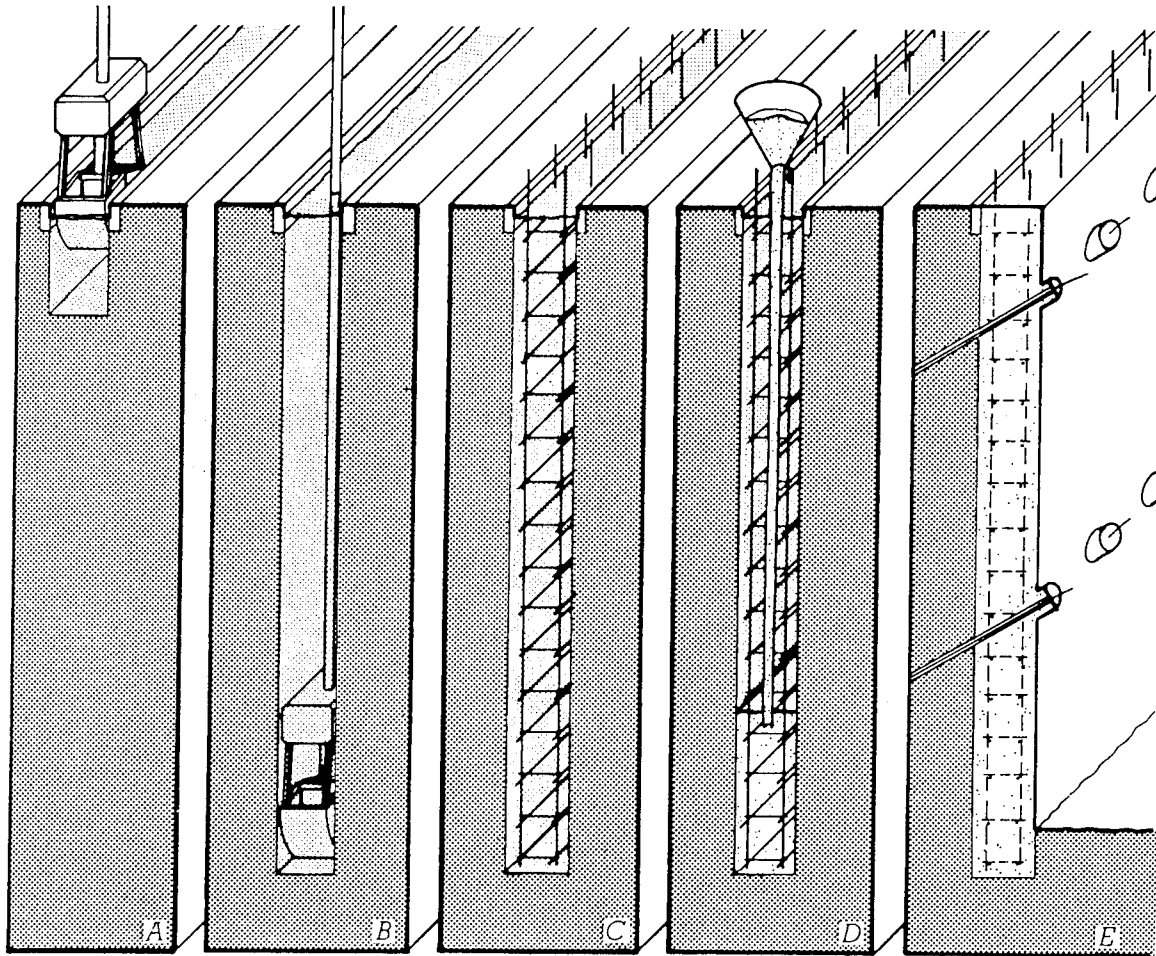

Source: Allen, Edward, *Fundamentals of Building Construction Materials and Methods*, ©1985, John Wiley & Sons, Inc. Reprinted by permission.

Figure 8. Slurry Wall.

A bracing system is used to secure the sheeting to the excavation edge (Figure 9). One type, crosslot bracing, uses wide-flange steel columns, driven into the ground with crossbeams from one side to the other, and horizontal whalers that support the sheeting. Rakers—angled supports that brace the wall from within the site—can also be used. These two systems are not used often—they hinder construction by supporting the sheeting from within the site. Tiebacks support the sheeting while maintaining an open excavation. At the whaler level, holes are drilled through the sheeting and the surrounding soil into rock or a layer of stable soil. Then, steel tendons, or tiebacks, are inserted into the holes, grouted, post-tensioned, and fastened to the whalers. A similar procedure, using post-tensioned steel rods, is used for rock stabilization.

Systems that only use the bracing system are tiebacks, soil nails, or a combination of the two. The tieback system uses post-tensioned tiebacks, but also incorporates concrete pads to achieve the lateral pressure on the soil during post-tensioning. Soil nailing uses steel rods smaller than tiebacks, but anchors them more often. The whole system, when in place, works similarly to friction piles, in that it uses friction to bind together the soil mass that it encompasses. Both systems use steel mesh with shotcrete to prevent local soil failure of the excavation face.

After the sides of the excavation are adequately sloped or braced, the site is ready for substructure construction. If the base for the foundation is rock, the rock is washed to promote a good bond with the concrete. This is usually done with a high-pressure water jet. Soil sites are prepared through grading and compaction. Each construction project is a unique challenge that requires a site-specific procedure. First, the earthwork survey crew surveys the area and sets up the offset survey stakes for rough grading, using the initial site layout and survey. The contractor uses bulldozers or scrapers to perform the rough grade, depending on the amount of cut and fill required. This is done by placing loose layers of fill at specified depths before compaction. Water trucks spray the fill to provide adequate moisture content for the specified soil strength, and to suppress the dust.

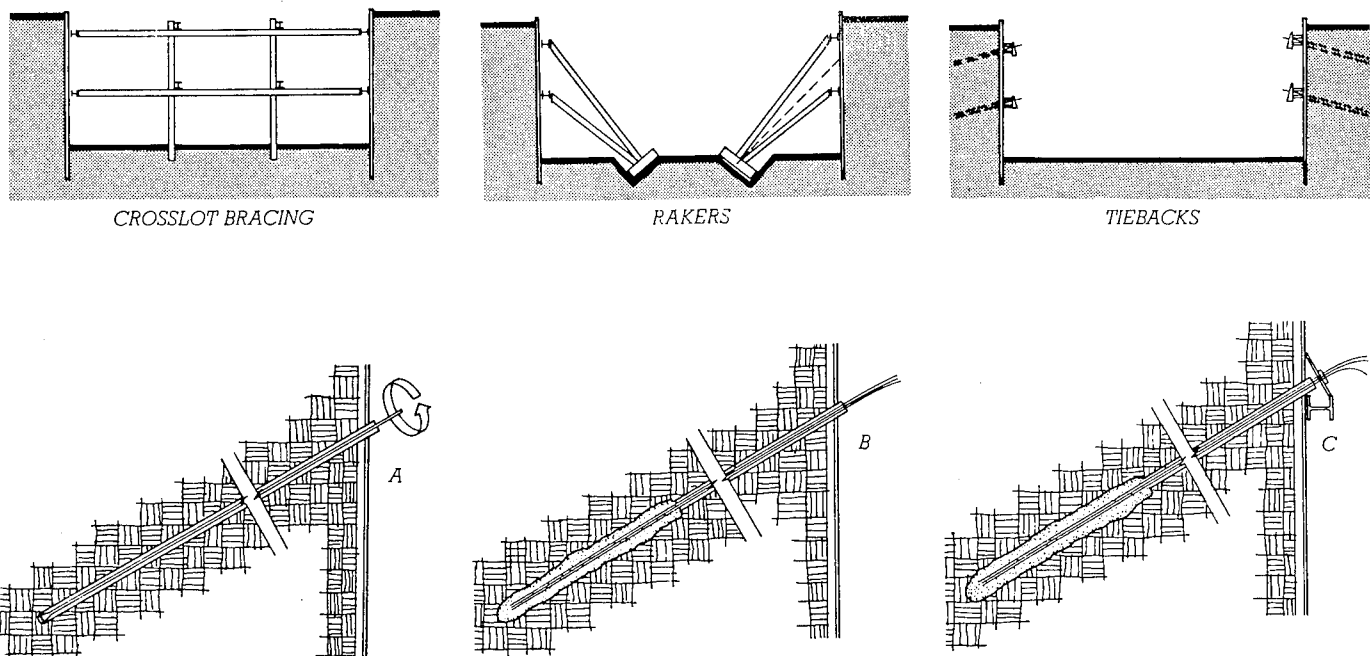

Source: Allen, Edward, *Fundamentals of Building Construction Materials and Methods*, ©1985, John Wiley & Sons, Inc. Reprinted by permission.

Figure 9. Bracing Systems.

After the site is leveled to rough grade, the layout crew checks the grade. If the grade falls within the allowed specifications, the crew places the final grade stakes (blue-top stakes) 3 ft outside the proposed worksite at about 10 ft intervals. If the grade is not within specifications, the survey crew replaces the rough grade stakes, and rough grading is repeated. The rough grade stakes also must be replaced if they are accidentally disturbed. The final grade is obtained by an experienced grader operator, who makes several passes, slowly cutting and filling, to achieve the specified tolerances. Although a grader has more flexibility, tighter controls, and greater speed than a bulldozer, the grader is mainly used only during final grading because the bulldozer has superior earthmoving and cutting power.

The final grade is compacted to a specified density by adding water, or scarifying and aerating to achieve the correct moisture content while compacting the soil (Tatum and Funk, March 1988). Typical compaction devices include towed or self-propelled rollers: smooth-wheel or grid rollers for sandy soils, pneumatic rollers for all types of soil, and segmented-pad rollers for clay or cohesive soils (Wood 1977).

After final grading, final preparations for foundation placement are executed. These include footing excavation and concrete form placement for small buildings; or survey and layout of piles or caissons, followed by excavation and concrete form placement for highrise buildings. The survey and layout of the piles, caissons, footing beds, and concrete forms are based on the initial USACE site layout and survey.

Tunneling. Tunneling is a specialized form of earthworks that involves the excavation and removal of earth from under ground without an open pit or surface. All tunneling procedures begin with a thorough geological and engineering investigation. The information obtained from this investigation is used to select the appropriate tunneling method. Various components of the methods include the means of ensuring safety, the specific tunneling method, mucking, and the tunnel-support system. The four most common tunneling methods are cut-and-cover, open-face shield, mechanical mole, and hard-rock tunneling.

Because the actual earthwork involved in a cut-and-cover operation is simply excavation, which has already been discussed, no further detail is necessary here.

The open-face shield method is used for tunneling through soft earth. A typical shield has three components: the hood, the middle-power section, and the tail. The hood, which projects from the shield to protect the workers, is forced into the earthen surface to be excavated. This is done by anchoring the back of the shield into the earth, then using jacks in the shield's main structure to force the shield forward. Material is loosened by digging or blasting the excavation face. As material is excavated, the workers remove the loosened material, or muck through openings in the middle-power section. The middle-power section provides internal support for the tunnel. Primary tunnel lining support timbers and lagging are erected at the tail. Mechanization has added earthcutting capability and muck collection and removal devices.

Mechanical moles, or rotary excavators, have closed faces with blades, teeth, and scoops that guide, cut, grind, collect, and remove loosened earth. They are used to tunnel into semi-rigid soils. They are not effective for excavating hard rock. During operation, the rotary excavator anchors its radial telescoping rib jacks into place, and drills until there is no free play remaining in the forward thrust cylinders. Then it sets the support legs while retracting the rib jacks, and moves forward to compress the thrust cylinders. As the tunneling progresses, concrete lagging or plates and ribs are placed for support. Around the support system, concrete grout is injected to fill the rock voids and distribute the load of the earth. A form of a rotary excavator for small-diameter bores (2 to 60 in.) is an auger. Because of its size, the auger can be track-mounted so it can move forward on the track, lock onto the rails, and use the rails as a base to force the auger head forward into the material.

Hard-ground tunneling is accomplished by detonating explosives in holes bored by machine-mounted drills, then collecting and removing the loosened rock or muck. The support system for rock tunneling is rock bolting. This involves drilling into the rock, inserting a steel bolt with a threaded expansion device, and turning the bolt to expand the anchor and secure the bolt. Then, a steel plate is anchored by the bolt to the tunnel wall. This post-tensioning compresses the rock mass to resist further movement. Bolt anchorage is increased by using a hollow bolt through which grout is injected. Sometimes after this, wire mesh is attached to the tunnel lining and is shotcreted to increase the tunnel's structural stability (Wood 1977).

Dredging. This specialized form of earthwork deepens channels and harbors by removing silt and other debris. Dredging is difficult because it deals with a medium that cannot easily be seen in its *in situ* condition. It involves many variables that make accurate, simple, and firm calculations almost impossible. The dredging process has not changed drastically since the advent of modern mechanical dredges in 1500, when Leonardo da Vinci invented the "dredge wheel" (Gren 1976). Since that time, the only significant change has been the invention of the centrifugal pump, which sparked development of the hopper-suction dredge.

There are two basic dredge types: mechanical and hydraulic. Mechanical dredges do not dilute and grade (separate soil particles by size) the dredged material, as hydraulic dredges do. But mechanical dredges require less power, cause less pollution at the disposal site, can operate with smaller disposal areas, and are more adaptable to long-distance transport than hydraulic dredges. There are three basic mechanical dredge types: dipper, bucket, and ladder. Different types of hydraulic dredges include cutterhead, plain, suction, dustpan, hopper, and sidecasting.

Dredging begins with a hydrographic survey to find out the location, amount, and type of soil to be removed. The hydrographic survey is performed by setting up a benchmark or control system on land. A ship travels through the water in a predetermined pattern, possibly marked by bouys, making soundings and taking soil samples. The result, a soil profile, is analyzed to determine the amount, location, and type of soil that should be dredged. Then, the boundaries of the dredge area either marked with bouys or shoreline markers. While the area is dredged, vertical alignment is ensured through the control system set up for the hydrographic survey, or one constructed specifically for the dredge. The control system itself is checked daily and protected (Barry 1973).

Concrete Construction Techniques

Standard concrete techniques have evolved over time to ensure finished product quality. *In situ* concrete quality is achieved through correct conveying, preplacement tasks, placement, consolidation, finishing, form removal, curing, and protection.

Conveyance. Concrete is conveyed to the site in three different ways: centrally mixed, shrink-mixed, and transit-mixed. Centrally mixed concrete is mixed by a stationary mixer at the batch plant, then transported to the site by an agitator truck. Shrink-mixed concrete is partially mixed at the batch plant and the rest is done by a transit mixer on the way to the site. Transit-mixed concrete, as the name implies, is done entirely in a transit mixer. For short distances, concrete can be centrally mixed and transported to the site over a continuous-belt conveyer. This method keeps the concrete continuously agitated, but it tends to lose material and segregate the concrete. As a rule, concrete should not be used later than 90 minutes after batching (when the hydration process begins) or after 300 revolutions of the transit mixer drum. Past these limits, concrete strength will be greatly reduced.

Before the concrete arrives onsite, several preplacement tasks may be required. These include sample castings or panels showing the desired quality of construction, formwork erection, aggregate-layer

and moisture-barrier placement (if needed) and placement of steel reinforcement, expansion and control joints, embedments, and blockouts. Sample castings are placed and used for reference. They indicate construction assemblage method, special treatments, form ties, structural joints, and formed surfaces.

Formwork erection begins with the form layout. After formwork surfaces and their supporting structure is in place, parting compound is spread on the forming surface. This allows formwork to be removed without damaging the concrete surfaces.

When placing a slab on grade, topsoil is scraped away to expose the subsoil beneath. A layer of gravel is specified, placed, and compacted over the soil, and a moisture barrier is placed on the stone to make sure that water drains away from the slab and prevents water from infiltrating into the slab. Next, steel reinforcing mesh or bars are put into place.

The steel reinforcement materials are checked for corrosion before placement. If any corrosion is extreme, the steel will not be used. The placement of reinforcement materials requires spacing the bars according to specifications, laying the bars on reinforcing chairs or bolsters, splicing the bars together, tying the system at the intersections of the bars, and enclosing the top and bottom reinforcing steel in structural members with stirrups. When welded wire fabric or mesh sections are used, they are placed according to specifications and tied together with steel wire at specified locations. Then, expansion joints are secured in place to control concrete expansion and reduce cracking of the slab. Any blockouts required for ducts, piping, or embedments are made at this time.

After the preplacement tasks are completed, concrete placement begins. Placement includes depositing and consolidating. Concrete depositing may be done in various ways. One is straight out of the truck by chute into the structure. Another deposition technique involves a bottom-release bucket alone, or with a dropchute laydown type. It is important to know that dropping concrete from heights of greater than 5 ft will segregate aggregate and paste. This distance can be increased to 15 ft, however, if a superplasticizer is added. A third deposition technique is by buggy. A worker drives the buggy on a supporting structure (such as wood planks) to the transit mixer. The buggy is filled and driven to the correct placement location, then dumped. A potential problem with this method is that any excessive horizontal movement of the concrete can cause segregation. One other desposition technique is pumping. Pumping requires the use of concrete that has normal to high slump, contains more fine aggregate than usual, and includes workability admixtures.

Consolidation must be done concurrently with placement—usually with the aid of an immersible vibrator. The vibrator is immersed at specified intervals in concrete with a maximum lift of 12 in. (or 6 ft with superplasticized concrete). Form vibration is used to supplement immersion vibration where steel reinforcing materials or structural members create too much congestion to use only an immersible vibrator. A consolidation evaluation is performed by any individual worker. Too much vibration may cause segregation of aggregate and paste.

After consolidation, finishing takes place. In the first step of finishing, the concrete is screed to attain a generally level surface. Next, the surface is bull-floated (using a large wooden or metal float), then hand-floated, and finally hand-finished with a metal trowel. Hot-weather concrete placement often involves moistening the concrete surface to prevent accelerated curing. Following this, a curing compound may be applied, or a plastic sheet is placed over the exposed concrete to retain moisture and promote optimal curing. After the concrete has cured, the curing sheets and formwork are removed.

Masonry Construction Techniques

The quality of a finished masonry structure is achieved through correct mortar mixtures, masonry erection, pointing, and cleaning.

Mortar mixing is done onsite, and is proportioned to achieve the correct bond for the specific type of masonry unit used. First, a mortar bed is placed either on the foundation or a previous course of masonry units. Then the masonry unit's head is mortared, or "battered," then placed. The unit is checked for correct height and plumb by comparing it to a level stringline attached to the corner masonry units. Corners are continually checked for plumb because they are used to orient the stringline. At a specified vertical interval (typically 2 ft), steel reinforcing ties are placed in the wall to provide lateral strength. When masonry is used for load-bearing walls, steel reinforcement is mortared in place within the units' cavities. At breaks in the air space or space between two walls of masonry (if any), flashing and weepholes are placed. Before the mortar has set, the joints are tooled, or struck, and the face of the wall is cleaned.

Steel Construction Techniques

Finished product quality for steel construction is achieved through correct raising, setting, and connecting of structural members. A truck or crawler-mounted crane lifts the steel members to erect the first tier of structural framing. According to the erection drawings prepared by the fabricator, the columns for the first tier—usually in sections two stories high—are raised from organized piles on the site and carefully lowered over the previously constructed foundations with projecting anchor bolts. The steel-column base plates may be placed on a leveling plate set on a mortar bed or on leveling nuts, then grouted after the frame is plumbed. After setting the column, ironworkers use nuts to temporarily secure the columns before they are plumbed.

After the first-tier columns are set, the first-tier beams and girders are raised and bolted into place. Then sufficient bracing is installed to maintain the structural frame's lateral stability. Lateral bracing systems include exterior cables for anchoring the structure to the ground, and interior diagonal bracing—either cables or struts. After the first tier is erected, it is plumbed using diagonal cables with turnbuckles (plumbing guys), and alignment is checked with plumb bobs or transits. After this, all connections are tightened or welded, baseplates are grouted if necessary, then permanent bracing is rigidly attached, if specified. The second-tier construction process begins with the setting and connecting of second-tier columns to the first-tier columns through splice plates. After this is completed, the rest of the structural framing is erected the same as it was on the first tier.

According to OSHA's code, workers shall be protected on the construction site from falling more than two stories. To satisfy this requirement, steel decking should be laid over and fixed (welded or screwed) to the structural frame every two stories. This not only reduces the distance a worker can fall or drop a tool, but also provides a convenient work surface for tools and materials. If composite concrete-steel slabs are specified for the project, steel shear studs are welded at specified locations to the structural members through the decking.

The construction of Quonset huts falls under the category of steel construction. Construction of Quonset huts start with the erection and connection of a structural steel frame to a concrete foundation. After the frame is erected, prefabricated steel panels are lifted into place and attached (usually screwed) to the steel frame. Finally, the steel panel edges are sealed to prevent water and air infiltration.

*OSHA: Occupational Safety and Health Administration.

Overview of USACE QA Practices

USACE QA processes are discussed here to provide the basis for identifying any techniques that may be rendered ineffective by current or projected construction automation. Because construction materials and processes affect the nature of the applicable QA procedure, any changes in materials or processes resulting from automation may reduce or eliminate the effectiveness of conventional USACE QA techniques.

Sitework QA Methods

USACE QA methods for sitework construction verify the quality of sitework materials and procedures, including the verification of site-positioning systems. EP 415-1-261 (Volume 1, Chapters 1B through 2E, and Volume 2, Chapter 2O) was referenced for information about sitework construction QA. USACE sitework QA techniques specifically evaluate materials and equipment, site-positioning systems, and site preparation, layout, survey, and earthwork.

QA for Site Preparation. QA for clearing and grubbing involves checking permit restrictions, rights-of-way, the contractor's schedule of operations, and work limits and requirements. It also includes verifying the implementation of safety measures, such as relocating or marking power lines and other utilities, and identifying any other hazards. These inspections are completed before clearing and grubbing begin.

The QA inspection for swamping examines the plan for removing any obstacles to felling, such as underbrush, vines, and small trees. Inspections are also made of equipment, protective devices, and warning signals. Finally, the inspector checks the proposed swamping method, including spacing and placement of swamped material.

Before felling operations, all tree-climbing equipment, topping rigs, axes, crosscut saws, bulldozers, and winches are inspected. Next, the inspector indicates all possible dangers on the site, such as leaning or hollow trees. He or she also checks the felling procedures planned for dangerous areas such as slopes, slippery terrain, rock, or outcrops. Any trees that should remain standing are marked and protected. QA for decking and logging includes checking the bucking, loading, and hauling equipment, and the planned procedures for stacking, transportation, and dumping (2A-02).

The inspection procedure for grubbing involves verifying the defined operation area and ensuring that the grubbing procedure conforms to the previously approved procedure. During grubbing, the inspector observes the removal depths of stumps and matted roots, and makes sure the holes are filled and compacted as specified. Disposal and clean-up operation inspection involves checking the equipment and procedures for piling and disposal. The local fire district, county, state, Environmental Protection Agency (EPA), and U.S. Fire Service Regulations are checked before any refuse is burned (EP 415-1-261).

QA for Site Layout. During site layout for USACE projects, the Government must establish and indicate baselines and benchmarks. The contractor uses these points to perform the survey and execute the work. It is the QA inspector's job to make sure that the procedures stated above have been performed, that the contractor has used an adequate number of stakes and templates, and that the contractor's lines and grades of work are checked continually. Layout tolerances within the specifications are used when evaluating a layout. Any deviations from the specifications or drawings must be reported to the inspector's supervisor.

QA for Surveying. The Government is responsible for all surveys and work quantity calculations. All instruments and equipment, such as levels, transits, tapes, and rods, are checked to make sure that they

are capable of achieving the specified degree of accuracy. During the quantity survey, the inspector makes certain that any cross-section work uses the same horizontal and vertical controls as the USACE construction layout. Also, the inspector verifies that there are enough intermediate cross-sections to account for abrupt changes in the slope of the terrain, and that these cross-sections extend far enough to include "catch points" of excavation and fill slopes, with generous allowances for overexcavation. The inspector also makes sure the contractor checks leveling by closing on benchmarks, checking distances at the ends of each cross-section by taping into an auxiliary parallel baseline, or by comparing each cross-section with an adjacent cross-section. The plans are frequently referenced to make sure enough cross-sections are taken. Any conditions that differ from the plans are indicated on the plan.

QA for Earthworks. USACE QA methods for earthwork construction begin with a check of the survey report and the laboratory's soil test report. In addition to this, material sample tests, such as capillary water barrier tests for under-floor slabs and base material, are confirmed.

Topsoil work consists of stripping, stockpiling, and spreading. The inspector must ensure that the topsoil is stripped by the specified method, to the specified depth. Simultaneously, he or she must check to see that the topsoil is not contaminated with the subsoil, roots, stones, etc. Then, stockpile location and work order are inspected. During topsoil spreading, topsoil scarifying and bonding are verified. This includes ensuring that topsoil is not placed on frozen or muddy ground.

Excavation begins with checking previously performed construction tasks. First, photographs of the construction site are taken to check the initial cross-sections and later to check the project's progress. Next, the log borings are reviewed to determine the water table level and compare the excavated soil to the log boring report. If dewatering is needed, these procedures are observed, and any footing beds in this area are checked for softness or disturbances.

Marked utilities are verified against existing utility maps. All equipment involved is examined. The inspector then checks the material borrow pits for correct drainage, adequate stripping (no soil contamination), and correct removal of materials (first in, first out). During excavation, the work area is inspected for correct drainage.

The excavation edges are checked for a safe angle of repose or an adequate soil-retention system, and structures on adjacent areas are observed for settlement. Fill materials used to correct overexcavation, and the proposed fill and compaction processes, are evaluated.

Rock excavation QA involves checking the contractor's plan of excavation against the approved one. The excavation technique is also checked for compliance with city, county, and state regulations—especially if it uses blasting. The drilling and blasting pattern and sequence, as well as the qualifications of drillers and powdermen, are verified. The inspector checks the results of the blast to ensure that any overbreakage or damage to existing structures is shored and fixed. Trench construction through rock is inspected for specified depth, size, location, and drainage.

The inspection procedures for foundation preparation initially include the QA issues for clearing and grubbing. The inspector ensures that the designation and protection of all features that are to remain. Then, the foundation conditions in the plan are compared to the actual conditions. Any differences are noted. Before concrete placement, the foundation trench is checked for correct bed compaction and possible contamination, and is protected against any surface water from entering the trench.

Inspection for embankment and backfill operations begins with identifying, marking, and protecting the Government-established benchmarks and baselines. Other QA issues in survey control include verifying that the contractor's layout of work complies with the specifications, and that final surveys are

performed after each phase of work. Preparation inspection includes checking vegetation removal, ground-surface compaction, and plowing. Stepping or benching is specified for inclines greater than one in four (14 degrees). Throughout these operations, the inspector monitors the quality of the haul road and ramp. During ditching, the contractor's maintenance of ditches and disposal of material is checked. Before the contractor performs embankment tasks, the inspector checks the contractor's equipment and proposed methods to ensure that the soil's moisture content is used to its best advantage. During placement operations, the soil is continuously checked to verify that it contains no oversized stones, roots, or other debris, and that there is sufficient bonding between soil layers. Backfill situations require the inspection of the backfill and bed material for specified plasticity, gradation, and frost susceptibility. The backfilling process is checked for correct depth and compaction of materials, and any necessary dewatering.

Final grade and subgrade preparation QA techniques include verifying that the contractor is using the correct lines and grades, and that the specified smoothness is attained while providing adequate drainage. In addition to this, water content and soil density are inspected. This is done using the sand cone test (AASHTO T-191, ASTM'D 1556), the balloon test (AASHTO T-205, ASTM D 2167), or nuclear tests (AASHTO T-238, ASTM D 2922).

The sand cone test is performed by first making a small excavation, weighing the excavated soil, oven-drying it, and re-weighing it to calculate the water content. The sand cone apparatus is then filled with Ottawa Dry Sand. By weighing the apparatus before and after the sand is added, the sand's weight and the hole's volume are calculated, indicating the dry density of the soil.

The balloon test is similar to the sand cone test, except the balloon in the hole is filled with water from a graduated cylinder. The hole's volume is determined found by the amount of water used to fill the balloon.

Because the sand cone and balloon tests are time-consuming, a nuclear test is sometimes preferred. This test involves an apparatus that emits gamma rays into the soil. The rays are scattered back from the surrounding material and measured by the device. The smaller the measurement, the more dense the soil. One problem with this technique is that if there are large rocks or concrete near the meter, or excessive moisture in the soil, the meter may return incorrect readings. Another problem is the danger of exposing the user to gamma radiation.

Earthwork construction QA also covers trenching for underground pipe systems and dredging. Trenching QA for underground pipe systems begins with a thorough examination of the plans, specifications, and existing underground utilities to check for any discrepancies. Next, USACE performs the initial layout and site survey for the proposed trench construction. Following this, the underground pipe system is installed.

Dredging-related operations that USACE typically encounters are hopper, bucket (dipper and clamshell), and hydraulic (pipeline) dredging, and rock drilling and blasting. Before dredging, the inspector checks the control system, which includes verifying the location of the vertical and horizontal control marks, and making sure they are protected. Also, any underwater utilities and the specified dredge location are verified. The horizontal and vertical controls are verified daily during hydrographic surveys. During dredging, the material is periodically checked and compared against job specifications specified. The inspector makes sure that this material is disposed of as specified in navigable waters, and that its location is documented. Any blasting techniques need to comply to state, county, municipal, and Coast Guard regulations. After dredging, the final grades are checked for compliance to specified ones.

*ASTM is the official name of the organization which was formerly known as the American Society for Testing and Materials.

QA for Concrete Construction

USACE QA techniques verify material quality and proper construction techniques to ensure the quality of the final product. EP 415-1-261, Chapter 3A, was referenced to summarize USACE QA issues and techniques for concrete construction. The USACE QA process evaluates materials, equipment, and techniques before and during concrete batching, mixing, and placement.

Before concrete batching and mixing, materials, equipment, and processes are examined. This begins with analysis of material sources, and procedures used in their storage and handling. The contractor's submittal of material sources and samples, trial mixes, and material test approvals for cement, coarse and fine aggregate, water, any admixtures and steel reinforcement. These inspections guarantee that the concrete materials, mix proportions, and samples submitted by the contractor meet job specifications. Next, storage and handling methods, from the mill or quarry to the batch plant, are examined. Cement and admixture containers are inspected to ensure that they are weather-tight and prevent out contamination.

Material and equipment are also examined during concrete batching and mixing. At the concrete batch plant, the inspector ensures that the oldest cement is used first and that any over-aged cement is tested before use. At the quarry and batch plant, proper grading and separation of aggregate piles is verified. The batching equipment is inspected for proper operation, including material scales, compartments, and gates. Actual batch load sizes are compared to transit mixer capacities. The mixer is checked for water-tightness, hardened concrete on the mixing drum's walls, mixer blade wear, rotation speed and revolution-counter accuracy.

Mixing time, moisture content, and graduations of aggregates are examined. Slump and entrained air content tests are performed as often as necessary to provide all record data prescribed by the USACE District office or job policy. The mixed concrete's consistency is evaluated through a slump test, and its air content through the volumetric method. The slump test involves filling a premoistened, hollow metal cone with concrete, consolidating the concrete with a rod (3 layers or lifts, striking 25 times each layer), and striking off the excess concrete. The metal cone is carefully lifted straight up and slump is measured as the difference between the original concrete level and the level to which it settles. The volumetric method involves filling a steel bowl with concrete, consolidating it, and striking it off. Then, a meter is placed and secured on the bowl. Water is added to a specified point on the graduated neck. The screws are tightened and the mixture is agitated. Following this, isopropyl alcohol is added and the air content is determined.

The inspector also looks at equipment such as vibrators, buggies, hoppers, dropchutes, mixers, and concrete pumps for operability and cleanliness, to ensure that they are the correct type, and to make sure there is enough equipment onsite to complete the project on time.

The preplacement QA inspection begins with visual examination and approval of sample concrete panels against the specifications. The inspection of concrete forms addresses their appropriateness to the structural system, the soundness and quality of the forms, and the soundness and quality of the structure that supports the forms. Formwork placement is then checked against plans and specifications. When ensuring the soundness of the formwork, the spacing of structural studs and whaler support is checked for uniformity to prevent differential deflection. The inspector looks for sufficient and appropriate braces and tie rods securing the forms to the studs in four directions. Material quality and joint (expansion, contraction, and construction) placement is compared to the shop drawings, plans, and specifications. In addition, all embedded items and steel reinforcement materials are checked to ensure that they are properly secured. Finally, formed surfaces are checked to determine whether adequate releasing compound has been applied.

During concrete placement, concrete cylinders and beams are made to test the concrete's strength. After the concrete has cured for 7 days, the specimens are tested. If they do not provide the specified strength, core samples are taken of the *in situ* concrete. If the average strength of three specimens is not greater than 85 percent of the specified strength, then nondestructive evaluation (NDE) and an *in situ* load test are performed to determine actual concrete strength, and to test the structure for typical loadings. If the concrete fails these tests, it must be removed. Also, concrete free-fall during placement is observed, and limited to 5 ft or less to prevent segregation. Horizontal movement of concrete is also observed and regulated to prevent segregation. The inspector makes sure the concrete is placed quickly enough to prevent cold joints. Form supports and ties are checked and adjusted, if necessary. The placement and full consolidation of appropriate lift depths are verified before another lift is placed. Vibration is observed to ensure that it consolidates the concrete without segregating it.

The inspector verifies that the concrete surface is firm enough to prevent too much paste from surfacing, and is satisfactory for floating. The inspector makes sure that troweling begins after the floated surface has hardened enough to prevent drawing more mortar to the surface, but is still workable. The concrete finish is evaluated by comparing it to the finish on the approved sample panel. As soon as the concrete has sufficiently cured, the forms are removed and the concrete surfaces are checked for damage. If the inspector discovers damage, the concrete surfaces are immediately repaired.

USACE QA techniques for concrete curing ensure that a curing membrane completely covers the moistened concrete slab to prevent water vapor loss, for continuous moist curing.

Various methods are used to protect the slab from all atmospheric conditions. Thermometers are used to ensure correct curing temperatures.

QA for Masonry Construction

EP 415-1-261, Chapter 4A, was referenced for information about USACE QA techniques of masonry construction.

Initially, certificates of material approvals (including the mortar mix) are examined. After sample-panel quality is approved, the samples are placed near the work in progress for easy reference and protection against damage.

Next, the QA inspector verifies the quality of material. For example, shrinkage and condition tests are performed on the CMUs to determine if the units (1) are within the specified shrinkage tolerance and (2) contain enough moisture to prevent excessive shrinkage after placement. Next, the onsite materials are tested to make sure they are within the approved color, texture, and grade tolerances. The materials include masonry units, anchors, ties, joint reinforcement, rebars, mortar ingredients, insulation, etc. In addition to this, the storage areas are checked to make sure they provide an environment that will preserve material quality. For example, paragraph 4-05.a.(3) of EP 415-1-261 requires that masonry units be stored above ground level, and are completely covered with waterproof materials such as a tarp or plastic sheeting.

USACE QA for protecting the masonry assemblage during construction includes verifying that the contractor prevents temperature extremes or fluctuations from affecting product quality. The inspector observes a "dry-run" to check and correct any masonry dimensions that do not coincide with existing foundations or structural framing. As wall construction progresses, various items and their placement are checked against tolerances in the plans and specifications. These items include control joints, joint reinforcement, weep holes, insulation, plumb, and height. Finally, joint tooling is inspected for consistency, and the masonry face is checked for cleanliness.

QA for Steel Construction

USACE QA for steel construction includes not only materials and erection processes, but also the equipment used to execute the processes. EP 415-1-261, Chapter 5A, was referenced for information on steel construction QA.

As a preparatory inspection, items such as shop drawings, mill test reports, welders' certificates, proposed welding procedures, painting requirements, and the erection procedure (including special requirements) are reviewed. Onsite materials are checked against shop drawings and specifications. The steel is inspected to ensure that it is new and of the correct shape and size. Any shop fabrication or painting is certified, and if any parts are damaged, action is taken immediately. Storage of the steel should be above ground level, and in an area that will not obstruct site traffic.

QA for the steel-erection procedure starts with the inspection of the contractor's crane and its cables. Next, the foundation and anchor-bolt placement are checked against the erection procedure, and any necessary corrections are made. After the base plates are set, they are leveled and set on a clean concrete foundation.

During structural alignment, support wires are checked for tautness. Rough handling of structural members, such as placing a member using a sledgehammer, is prohibited. Steel structural members are bolted or welded. Satisfactory bolting requires correct alignment of bolt and hole. After the connection is made, bolt heads and washers are checked to make sure they rest squarely against the steel, and tensioned as specified. If welding is required, the inspector must check that the equipment and the welder are certified. Completed welds are checked against the shop drawings. They are also examined for size, length, location, appearance, surface defects, craters, undercutting, overlapping, cracks, etc. Unacceptable welds must be removed, rewelded, and inspected promptly.

Before painting, the inspector verifies that the surfaces are clean. Concerning steel decking, USACE QA procedures require either a weld or screw connection. Location schedules should follow plans and *Steel Deck Institute Design Manual* (Section 5C-04). Screw connections cannot be used in high-wind environments, and welded connections must be painted.

3 THE STATE OF CONSTRUCTION AUTOMATION TECHNOLOGY

This chapter discusses issues in technology transfer of construction automation, automated systems currently on the market, and R&D trends in construction automation systems.

Technology Transfer of Sitework Construction Automation

It was necessary to identify current machine automation trends for sitework, concrete, masonry, and steel construction, and predict the status of these disciplines in 15 years to determine when (or whether) construction automation technologies might require changes in USACE QA practices. A thorough review of the literature revealed the approximate amount of time that automated technologies tend to spend in initial design development, prototype development, and implementation/final acceptance on a construction site.

According to the literature, sitework construction technologies tend to require fairly short technology transfer periods. One example is partially automated grading. The concept was tested in 1974, when a laser supplier mounted a laser on tractor-towed scrapers. They were used by Arizona farmers to cut vast areas at dead level, to allow efficient flooding of the soil. For 2 years there were no major attempts to systematically develop and market the tool. But in 1976, a laser supplier and a small grading contractor in the San Francisco area began jointly developing the partially automated grading system. Within 10 years the system was fully developed, implemented, and accepted on various U.S. construction sites (Tatum and Funke, March 1988, pp 19-35).

Technology transfer durations for sitework technology developed overseas and imported into the United States are estimated to be about the same as the domestic transfer time for U.S.- developed technologies. This is concluded because Japan and the former Soviet Union had developed and implemented a laser-guided land-leveling system by 1973 (Torisaki and Shinichi 1988, pp 132-135). This represents quick development considering that the laser was invented only 11 years earlier (Brotherton 1964, pp 199-201). But it took another decade for the technology to be accepted on U.S. construction sites.

The relatively short technology transfer duration for sitework construction automation is a result of the nature of the work. Sitework, in general, has been an equipment-intensive art rather than a strict science. Therefore, its cost can vary considerably depending on how good the "artist" is. Partially automated grading systems can quantify much of the art into a science. When the process is mechanized, the contractor has a better idea of how long it will take to achieve the specified cut and fill. Equipment that enhances productivity is readily adopted to replace old equipment. There is less resistance from construction laborers because the equipment enhances their productivity, which in turn facilitates its acceptance by the construction industry.

One condition that inhibits the implementation of construction automation techniques on USACE projects is the requirement that Government personnel perform initial site layouts and surveys. By providing this "free" service, the Government increases its own costs while discouraging the use of innovative technologies. If USACE did not supply the means for site orientation or provide benchmarks, sitework contractors would have to create a site orientation or structure to organize their work. The contractors would see that money saved from not performing a site layout would outweigh the initial costs of automated equipment. Until this cumbersome requirement is eliminated, the transfer of automated construction techniques to USACE construction sites will be hindered (LeRoy T. Boyer, professional discussions, 1991-1992).

Technology Transfer of Concrete, Masonry, and Steel Construction Automation

Based on a review of concrete, masonry, and construction automation technologies from around the world, U.S. technologies appear to take more time for development and acceptance than Japanese technologies. However, in these three areas, a few devices and construction techniques that could be considered automated have been accepted and used widely on U.S. construction sites. One such technology is concrete slipforming of building cores and pavements. Both applications were developed and automated in the 1950s, and after "debugging," were finally accepted in the 1970s (*Concrete International*, October 1979).

Marvin Minski, one of the pioneers of artificial intelligence technology, has stated that automated technology generally requires about 20 years to develop (Minski 1985, p 22). A 1979 study of the U.S. construction industry found that even construction innovations that provide significant savings to the user can take 30 years to be widely accepted on the construction site (Ventre, November 1979).

To better understand the reasons for the amount of time required for transfer of automated technologies to the U.S. construction industry, it is helpful to examine a typical scenario of construction automation technology transfer. Initially, a concept for automating a construction task or process is considered by an individual or a group of professors, students, or researchers. The concept tends to evolve into various possibilities and applications. Eventually, one version of the concept is chosen and more fully developed. Once a solid concept is developed, a paper or thesis is prepared, submitted, and presented at a symposium. This is the beginning of the *design* stage. The concept may be further developed, either by the original developer or one of the peers at the symposium. Sometimes the concept remains dormant until it is seen by another professor, student, researcher, or someone in the construction industry. Design refinement and possible development of a prototype may follow.

The *prototype* stage begins when the design is refined and a prototype is constructed. If the concept develops into a useful prototype, it may attract a sponsor in the construction industry, who will pay for the right to evaluate it for potential company or commercial applications. If the company decides the technology is useful, it will buy the rights to either commercialize the technology or adapt it to company-specific needs. Then, if the technology attracts initial industry users without posing any serious problems, and if the benefits (increased productivity, scrap reduction, improved safety, etc.) outweigh the costs (purchase, use, maintenance, possible increases in workman's compensation insurance rates, etc.), the technology will become an industry trend. This is considered the *implementation/acceptance* stage of the automation technology.

Considering that much automated technology is transferred to the United States from overseas it is also necessary to examine a typical construction technology transfer scenario first within the foreign country, then to the United States. Because Japan has the most advanced overseas construction automation industry, its typical technology transfer scenario and duration will be examined. Japan's R&D automation technologies in concrete, masonry, and steel construction take less time to reach and be accepted in its domestic construction industry than in the United States or other construction industries. An example can be seen in the WASCOR (Waseda Construction Robot) project. The project is headed by Yukio Hasegawa, one of the top robotic researchers in Japan. It includes many of his colleagues at Waseda University's System Science Institute, nine top Japanese construction firms, and two construction machinery manufacturers (Hasegawa, June 1986). This is a typical example of the R&D network in Japan, which "links practically every board room and laboratory in the country" (Cutler, December 1989).

The fact that construction R&D in Japan is a combined effort of universities, the construction industry, and the manufacturing industry, the development process is expedited by gaining the construction industry's acceptance of a technology during the design development phase. As a consequence, concepts

from the research are developed into practical automated devices within each of the participating construction firms. Devices such as concrete distributors or steel-erection devices are developed in 8 to 10 years (Skibniewski and Russell, June 1989). Under the construction industry's influence, any resulting automation device tends to be an "improved tool," which simply automates a traditional construction task.

Although Japan's technology transfer to the construction industry takes only 8 to 10 years, for a technology development there to affect USACE QA techniques, the device would have to be widely accepted by the U.S. construction industry. Japanese automated technologies developed by 1985, such as automated concrete screeds and finishers, have been only somewhat successfully tested on a few U.S. construction projects (Cranmer and Tucker, November 1990). Considering this, one can predict that the total process of foreign technology transfer, first within the country and then to the United States, generally takes just as long as the acceptance of a U.S.-developed technology in the domestic industry—about 20 years (Skibniewski and Russell, June 1989). To predict the status of construction automation technologies over the next 15 years, typical durations for each development period were projected.

Reasons for Excessive U.S. Technology Transfer Duration

The main reason U.S. technology transfer to the construction industry takes so long is the fact that the construction industry provides only limited support to R&D efforts. Other important reasons, cited by Gatton and Kearny (October 1989), include:

1. Construction industry's reluctance to change
 - Initial reduction of construction efficiency
 - Workers' fear of being replaced
2. Construction industry's organizational structure
 - Fragmentation of material, equipment, construction, and design company efforts
 - Competition among companies pursuing short-term goals
3. Liability issues and rising workman's compensation rates
4. Restrictive building codes that encourage using time-tested materials and processes
5. Lack of Government support for innovative construction technologies.

Other factors retarding construction technology development in the United States include the building industry's lack of competitive design, the lack of patent incentives, and current Government contract policies, which in effect reward mediocrity (Halpin, October 1990).

Survey of Automation Technologies

In addition to reviewing current technologies for automation of sitework, concrete, masonry, and steel construction, the following sections also discuss comprehensive automated building systems—systems that employ automated devices from several different construction categories.

Sitework Automation

Many machine-automation technologies are currently available for sitework construction. As shown in Table 1, automation has been applied to two main categories of sitework: surveying and earthworks. Drawings of many sitework automation devices are included in Appendix A.

Automation of Surveying. Currently available systems automate site metrology and investigation. The site metrology technology systems include the total-station systems. These systems make distance and angular measurements in less than 1 second. Under good conditions, a typical laser transit is accurate (+/- 5ppm) up to 500 m. Companies that produce these devices include Nikon and Laser Alignment, Inc. They have been used in the United States since the late 1960s. Many devices compensate for atmospheric conditions if values for temperature and barometric pressure are input. However, compensation works only to a certain level of atmospheric moisture before the laser starts to refract.

In general, the available automated systems mechanize traditional surveying techniques. However, these technologies can also be integrated into mechanical systems of construction equipment, to enhance the performance through greater accuracy. These applications will be discussed under "Automation of Earthworks."

Another advanced technology, which has been used for navigation and surveying since 1983, is global positioning (Leock, June 1992). The U.S. military's Global Positioning System (GPS) is composed of about two-dozen satellites in orbit 11,000 m above the earth. Each satellite contains four atomic clocks, and sends time data and other information to describe its position. GPS receivers compare the signals sent from the satellites to their own internal clocks, and calculate the distance between receiver and satellites to determine their position. The best GPS receivers can determine their position with an accuracy of 16 m simply by locking onto the signals from four GPS satellites (Eng and Borrus, February 1992). The instantaneous position accuracy can vary with a multitude of factors affecting the signal sent by the satellite, so the average instantaneous accuracy is actually about 50 m. However, if the receiver—either stationary or moving—also receives data from a secondary stationary receiver that has attained its position, that receiver can determine its own position to an accuracy of 1 cm (EM 1110-1-1003). This positioning technique is called *differential GPS*.

GPS surveying systems, such as the ones developed by Trimble Navigation and Magellan, use the differential GPS technique. These systems use a static receiver at a known location, which uses positioning data from several satellites to calculate (in about 30 minutes) its position. This positioning data is then used to calculate correction data, to more accurately determine the position of another receiver at an unknown location. This second receiver can be carried in a backpack or hand-held, allowing the surveyor to walk around the site, gathering position data. This continuous position measurement takes positioning measurements every second, and inputs them into a computer database. The database is later accessed and mapped, or downloaded into a geographic information system (GIS). Global positioning surveying systems alter traditional surveying methods by eliminating the need for transits, tapes, etc. Also, repetition of the survey positions can be used as a site layout, but can be performed much more quickly.

A marine survey device developed by Komatsu, Ltd., is called the Remotely Controlled Underwater Surveyor (ReCUS). It is an eight-legged robot that can achieve underwater stability on uneven ground and against environmental forces. The device can work productively in a hazardous environment where a human would be very unproductive—and periodically in danger (Torisaki and Nakatsuji 1988).

Automation of Earthworks. Automated devices are available for excavation, trenching, tunneling, grading, compaction, and dredging. An automated laboratory device that used a system similar to the automated pipe mapping system is the Robotic Excavator (REX), developed by Carnegie Mellon

Table 1

Current State of Sitework Automation Research, Development, and Technology

Surveying Title/application of equipment	University/Corporation conducting research	Dev. stage* (Intl)	Dev. stage (U.S.)
Surveying			
Laser surveying	Nikon, Laser Alignment Inc., etc. Trimble Navigation Magellan	I	I
GPS surveying	Komatsu, Ltd.	-	I
ReCUS		I	-
Earthworks			
REX	Carnegie Mellon Univ./The Robotic Institute	-	P
Soft excavator	Foster-Miller, Inc.	-	P
Teleoperated excavator	Komatsu, Ltd.	I	-
TORCE	Deere and Company	-	I
ROME	Foster-Miller, Inc.	-	I
RRR excavator	U.S. Air Force, Deere and Company, U of Florida, Westinghouse	-	I
Automated excavator	University of Lancaster, England	P	-
Rock drill	Foster-Miller, Inc.	-	P
CASTEC System	Eagle-Picher, CASTEC, Ltd.	-	P
SSS-G	Shimizu Corp.	-I	I
Hydrofraise	Soletanche	I	I
High speed excavator	Foster-Miller, Inc.	-	I
Overburden excavator	Foster-Miller, Inc.	-	I
Automated tunneling shield	Fujita Corp. Kumagai Gumi Corp. Shimizu Corp. Nippon Telegraph and Telephone Public Corp. Mitsubishi Juko Giho The Robbins Co.	I	I

Table 1 (Cont'd)

Surveying Title/application of equipment	University/Corporation conducting research	Dev. stage* (Intl)	Dev. stage (U.S.)
Drilling jumbo (tunneling)	Kakima Corp. Tamrock British Coal Atlas Copco Anderson Mekaniske Verksted	I	I
Mini Mucker	Foster-Miller, Inc.	-	I
Laser grading	Spectra Physics Laser Alignment, Inc. J.N. Haley Pacific Coast Excavating & Grading Japan and Russia	I	I
Automated compaction	Fujita Corp. Komatsu, Ltd.	I	-
Seabed planer	IHC	I	-
Automated dredging		I	I

*D = Design development stage

P = Prototype

I = Implementation by construction industry

University. This device maps underground pipes, structures, and other objects using available utility records and ground-penetrating magnetic sensors. After underground mapping is completed, gross and fine excavation are performed. Gross excavation is performed by trenching or boring to get close to the pipe. Then, because pipes frequently contain explosive gases, a supersonic air jet is used to dislodge material without directly contacting the pipes.

Vacuum-driven earth extraction is also being investigated (Whittaker, June 1986). This system improves safety by removing the worker from a hazardous situation. Using an improved excavation tool, the system is essentially an upgrade of traditional excavation processes. Another device that promotes onsite safety is the Soft Excavator, developed by Foster-Miller, Inc. The hand-held device uses a rotary head to dislodge material and vacuum it away without disturbing buried pipes or structures.

Typical earth excavation has also been automated with machines like those shown in Table 2. Komatsu Corporation developed a teleoperated hydraulic shovel in 1978. A more highly developed excavator is the Teleoperated Remote Controlled Excavator (TORCE), a modified John Deere 690c excavator that has been used at Eglin Air Force Base (AFB) and the Milan, TN, Army Ammunition Plant to remove unexploded ordnance. The device was modified by the Air Force through the integration of visual and audio feedback, data links, a remote operator's station, and servo-hydraulic controls. The excavator can be controlled within 5000 ft by radio, or 1000 ft by coaxial cable. As the excavation proceeds, visual and audio feedback are carried through the data links to the remote operator's station, where the operator plans and controls the excavator's next task. The operator either manually manipulates the excavator or chooses one of the preprogrammed tasks, which is then performed by servo-hydraulic controls (Wohlford, Griswold, and Bode 1990). A similar automated excavation system, the Remotely

Table 2

Current State of Concrete Automation Research, Development, and Technology

Title/application of equipment	University/Corporation conducting research	Dev. stage* (Intl)	Dev. stage (U.S.)
Reinforcement			
Rebar arranging robot	Kajima Corp.	I	-
Automated rebar-unit assembly	Shimizu Corp. Ohbayashi Corp.	I	-
Semiautomated rebar tying	MIT	I	D
Composite Connections			
Studmaster	MIT	-	P
Forming - Slipforming			
Slipforming machines	Miller Formless	-	-
Dam slipforming	Kajima Corp.	I	I
Precasting			
Integrated const. system	Shimizu Corp.	I	I
Hollow-core slabs	Flexicore Co.	-	-
Placement			
Horizontal Conc. Distributor (HCD)	Takenaka Corp.	I	-
Concrete distributor	Kajima Corp.	I	-
Automatic placing crane	Ohbayashi Corp.	I	-
BPU runway repair	Foster-Miller, Inc.	-	I
Robotic conveyor arm	Raider Reach Mfg., Ltd.	-	P/I
Automatic dist. system for dams	Ohbayashi Corp.	I	-
Automatic transit system for dams	Fujita Corp.	I	-
Application			
Concrete spraying robot	Takenaka Corp.	I	-
Shotcreting robot	Kajima Corp.	I	-
MEYCO spraying robot	Ohbayashi Corp.	I	-
Shotcreting robot	Foster-Miller, Inc.	I	-
Shotcreting robot	Raider Reach Mfg., Ltd.	I	-
Robocon-earth retention	Ohbayashi Corp.	-	I
Slide press lining robot	Fujita Corp.	I	-
Consolidation-Vibration/tampering			
Automatic exterior vibrator/tamper	Ohbayashi Corp.	I	-
Finishing			
Screed Robo	Takenaka Corp.	I	-
Concrete screed	Shimizu Corp.	I	-
Mark Series (I,II,III)	Kajima Corp.	I	-
Surf Robo	Takenaka Corp.	I	Tested
FLATKN	Shimizu Corp.	I	-
Multiple task floor robot	Ohbayashi Corp.	I	-

*D = Design development stage

P = Prototype stage

I = Implementation by construction industry

Operated Mechanical Excavator (ROME), has been developed by Foster-Miller, Inc., for the U.S. Army (Foster-Miller 1992).

An extension of TORCE R&D is an automated excavator for rapid runway repair (RRR). The Air Force Civil Engineering Support Agency (AFCEA), along with Deere and Company, the University of Florida, and Westinghouse, initiated and developed a RRR excavator that will eventually be fully autonomous. This device required that the excavator can mount several different excavation tools, including a bucket, a compactor, and an impact hammer. This system is currently being used at Tyndall AFB, in Florida. Future development includes a fully autonomous navigation system, incorporating computer control of the excavator drive system with a gyroscopic positioning system (Crane and Nease 1990).

An excavator being developed at the University of Lancaster, England, uses higher "intelligence" than the previously discussed systems. As the excavator digs, rotation sensors at the arm's joints provide the computer processor data for keeping track of the arm's motions and, if necessary, switching to a different digging style. Continuing research is being done on obstacle-avoidance and laser-guided positioning. The first prototype was built at one-fifth scale, but it has now been successfully scaled up to a full-size excavator (Bracewell et al., June 1990).

Research also is currently being done in the field of earthworks areas of force recognition and excavation-depth determination through computer control systems. These technologies can indicate to the equipment operator how much the excavating arm is being stressed compared to its capacity, bucket depth, and soil type (Skibniewski and Ostoj-Starzewski, April 1989; Bernold, April 1991; Bullock, Apte, and Oppenheim 1990; Baecher, April 1988).

The ultimate goal for these technologies is autonomous site operation. To date, automated excavating systems have simply replaced or assisted the human operator to enhance performance. These automated excavation devices are essentially improved tools that perform traditional construction processes. Integration of positioning systems with excavation systems reduces the need to physically perform many traditional site-layout tasks by allowing layout and excavation to be done simultaneously. Even with these significant improvements in efficiency, accuracy, and safety, the end result is still the execution of traditional construction processes. Therefore, the overall construction process is left unchanged and does not make any established USACE QA practices ineffective or obsolete.

One job-specific automated device is the Rock Drill Hole Digging System, developed by Foster-Miller, Inc., which excavates holes for utility poles. The system consists of two high-frequency rotary percussive hammers mounted to a structural core barrel. This system, while more productive, is simply an improved tool for drilling holes into hard ground (Foster-Miller 1992).

Automated trenching has been developed by a few companies in the United States. The Castec System, developed by CASTEC, Ltd., and Eagle-Picher, can continuously dig a trench up to 25 ft deep and 12 in. wide (with 2 in. of clearance), at a rate of 20 ft per hour. As trenching proceeds, concrete is placed behind the cutting arm to support the trench walls. Precast concrete panels can be used in stable soils. This system digs trenches for continuously cast foundation work, utilities, retaining walls, dam cutoff walls, and water seepage control walls (Eagle-Picher 1992).

Another trench excavation system, the Cast in Situation Substructure System Giant (SSS-G), developed by Shimizu Corp., is used for the excavation of largescale substructures such as dams, underground tanks, and foundations for bridge piers. It can excavate up to 10 ft wide and 450 ft deep (Shimizu 1988). Similar excavation systems have been developed and used in Europe and the United States.

Foster-Miller, Inc., has developed for the Army a self-propelled, high-speed, high-capacity excavator that can dig a trench from 2 to 12 ft wide. Trenching is accomplished with an adjustable boom and cutting head. The undercarriage is able to move the excavator at 25 mph when not in service. Foster-Miller, Inc., also developed a continuous excavator. This device is based on an unconventional bucket wheel geometry that uses forward rotating buckets to provide a forward tractive force for the excavator (Foster-Miller 1992).

These trenching excavation devices are improved versions of existing equipment that take advantage of automation technology to minimize or eliminate the need for a human worker.

Automation for Tunneling. Automation technologies have been developed for tunneling into both soft and hard ground. Soft-ground automated tunneling technologies are essentially automated versions of mechanical moles or shield machines, which have closed faces with blades, teeth, and scoops to guide, cut, grind, collect, and remove loosened earth. An automated tunneling machine has a rotating cutting head, and rotary loader that dumps the loosened material on a conveyor leading out of the tunnel. A laser in the cutting head allows the operator to monitor the head's position, pitch, roll, and yaw. As excavation continues, the front section advances while the rest of the shield stays stationary and braced in place. After a cutting cycle is completed, the rear section is pushed forward, leaving an unlined tunnel section supported by the steel tail of the boring machine. The concrete slipformer, located in the tail, casts a 4-in.-thick concrete segment against the wall. The concrete mix contains an unsaturated polyester resin and fine sand as aggregate, so it cures quickly. Steel tubing segments can also be used for the tunnel support, but they limit the total bore length by causing excessive jack friction. Visual inspection is done using television cameras situated throughout the tunnel.

Extremely soft soil excavation is performed by tunneling devices that use earth-pressure systems to exert enough pressure to support the earthen face. These systems continuously pump slurry into the cutting chamber to maintain the appropriate slurry pressure. During tunneling, the muck and slurry (sludge) are removed from the chamber as new slurry is pumped. The slurry is separated from the sludge to whatever extent is possible and reused, while the muck is pumped out of the tunnel. Although this system supports the tunnel face adequately, it tends to waste too much slurry through sludge processing.

A process that eliminates this problem is the bubble shield method, which uses tiny bubbles to support the tunnel face. The bubbles are suspended in a foam, which defoams naturally after extraction from the cutting head chamber, or can be rapidly defoamed with a defoaming agent (Yamamoto, December 1989). Examples of companies that have developed this technology are listed in Table 1. Automated shield machines for tunneling are basically advanced versions of conventional mechanical moles, mechanized to a greater extent and adapted for varying soil conditions.

Hard-ground tunneling automation technologies involve "drilling jumbos," which drill blast holes into a rock face in a preprogrammed pattern. One version has been developed by Kajima Corp. This method produces a rough rock wall that is secured with rock bolts, which support the large rock masses within the tunnel walls. To prevent the tunnel walls from local failure or crumbling, the rock wall is shotcreted—either directly or after being covered with steel mesh. Drilling jumbos are used for increased accuracy of hole placement during tunneling. Companies that have developed this type of system are listed in Table 1.

After the tunnel face or walls are blasted, the rubble is cleaned up and removed (mucked). The Mini Mucker, developed by Foster-Miller, Inc., incorporates a slide-bucket system that digs, loads, stacks, and dumps the blasted deposits in one uniform, controlled cycle. It is controlled over a tether (cable) or by radio, and has a load capacity of 4500 pounds.

Automation of Trenchless Construction. Trenchless construction techniques have been developed to eliminate the cost of erecting adequate trench-bracing systems, reduce the disturbance caused by activities occurring on grade, and lower the risk of a worker being caught in a trench collapse. Trenchless construction techniques include plowing, pipe-jacking, and microtunneling.

Plowing devices can be used to place cable of many sizes. For example, almost 1000 miles of fiber-optic cable was placed across the northern Rocky Mountains using a cable plow attached to a Catapillar D7H tractor. To protect the cable beneath the ground, a concrete slipform paver was used in combination with the plow to encase the cable in concrete (*Highway and Heavy Construction*, November 1987, pp 60-61).

Pipe also can be placed by plowing. A post-trenching machine was used to bury 80 miles of pipe (3.5 ft diameter) off Australia's northwest coast. Plowing for pipe begins with setting the pipe in the correct position. The plowing machine straddles the pipeline, clamps the first piece of pipe, and lifts it between split plowshares into a roller cradle. The plowshares cut a V-shaped trench, into which the pipe slides. The pipe uses double opposing rod seals with an excluder seal, an outer gland seal to protect gland threads, a rod lug seal to protect rod attachment threads, and an external metallic scraper (*Hydraulics and Pneumatics*, August 1983, pp 10-11).

Pipe-jacking technologies place pipe directly underground. The process begins with ground preparation, so the correct penetration point and driving angle can be achieved. This may range from clearing debris from the side of a roadway embankment to excavating and shoring an area. A cutting shoe is attached to the front end of a pipe segment. Then a pneumatic or hydraulic jack pushes the pipe by extending a conical-headed cylinder. The cylinder is connected to an add-on cone, which, in conjunction with a soil removal cone, adapts the pipe-pushing machine diameter to the pipe diameter. Their conical shapes evenly distribute the driving force through each other and to the pipe. The soil-removal adapter removes soil entering the pipe as it is driven through the ground. After the pipe is driven into the ground, another pipe segment is attached to the previous piece, and sealed.

Microtunneling employs a small, automated device that drills a tunnel and places a tunnel lining for underground utilities. Microtunneling is similar to automated tunneling, but on a smaller scale. Unlike automated tunneling, microtunneling usually cannot be inspected using established USACE QA techniques, because the tunnel diameters are generally very small.

Trenchless construction alters the traditional pipe- and cable-laying process by eliminating the trench excavation and shoring tasks, and combining excavation and construction into a single, simultaneous process. Conventional QA techniques are not adequate for trenchless construction because the assessment of job quality relies on visual monitoring of the process. Because trenchless processes are executed underground, conventional visual inspection is impossible.

Automation of Grading and Compaction. Automated grading uses precision laser-based positioning technology to improve final grading tolerances, and to decrease costs through increased productivity, lower material usage, a shorter weather-dependent time window, and lower equipment-hours (Paulsen, March 1985). The automated grading system positions its cutting blade by adjusting it in reference to a baseline projected over the entire site by a rotating laser. This system includes a rotating laser transmitter, a receiver mounted to a mast on the grading equipment's blade, a microprocessor, a visual grade indicator, and a hydraulic control system for the blade.

Laser grading starts with setting up and calibrating the laser transmitter to a specified elevation, which takes about 30 min. As the grading equipment is driven around in a pattern chosen by the operator, the laser-sensitive mast sends its position to the microprocessor. The microprocessor calculates the

difference between desired and actual blade elevation, and commands the hydraulic control system to raise, lower, or angle the blade to attain the specified grade level (Tatum and Funke, March 1988).

Another technology that will affect sitework construction activities such as surveying, excavation, and grading is dynamic equipment positioning using kinematic GPS positioning. The GPS receiver would serve as the site benchmark, with a field receiver on the grader blade for differential GPS. A site diagram and the excavation plan programmed into the excavator's microprocessor could enable the device to autonomously excavate the site by using positioning information from the GPS receiver (Beliveau, April 1991). The implementation of GPS receivers on the construction site to direct or control the positioning of machinery would simplify sitework by eliminating the need to perform a site layout.

Automated compaction machines are used for embankments of fill-type dams or fills for highways. Japan has been the leading developer of this technology. The compactor can be controlled manually, remotely, or automatically. The system includes geomagnetic orientation and dead-reckoning sensors for determining location, and an ultrasonic sensor for obstacle avoidance (Fujita Corp. 1988). The automated compactor essentially mechanizes conventional compaction tasks.

An automated seabed-planing device has been developed by Komatsu, Ltd., to streamline harbor construction. The seabed planer can level up to 44 sq ft of seabed in 1 hour, at depths of 100 ft. The eight-legged device weighs 72 tons, measures 33 ft wide, and stands 26 ft tall. The seabed planer replaces workers in a potentially hazardous environment where productivity is inherently low.

Automation of Dredging. Dredging automation has developed around mechanization of various aspects of the suction-dredging process. First, the dredging vessel's position and orientation are determined through either the use of a single GPS point on the ship in combination with a series of ring-laser gyroscopes, or multiple GPS points on the ship. This information is input into a track-plotter system, which visually shows both the ship's actual and specified position. Second, to ensure that the correct soil concentration is being pumped, a specific-gravity sensor is used. Sensors also check for the correct material flow and load in the hopper (Ghosh, November 1987). The traditional dredging process is made more efficient by eliminating the standard site layout that checks and measures dredging progress.

The U.S. Army Topographic Engineering Center (USATEC) is using GPS to position ships as they place concrete revetment mats. Information about the ship's position, the placement depth, and the placement configuration is automatically input in a computer-aided drafting (CAD) system to produce "as-built" drawings of the revetment (EM 1110-2-1003).

Concrete Construction Automation

Many machine automation technologies have been developed for concrete construction, including steel reinforcing, composite connections, forming, precast elements, placing, application, consolidation, and finishing. Table 2 lists various automated devices, their stage of development, and their developer.

Appendix B includes drawings of some of the key technologies now available.

Steel reinforcing machine automation technologies vary greatly. They range from a simple forklift-type machine used to place large reinforcing bars on dams, to the prefabrication of reinforcing units using automated reinforcement-tying technology (Kajima Corp. 1988; Yamashita et al., June 1989; Wakisaka et al., June 1990). These technologies have been implemented and accepted by Japan's construction industry, but have not yet been accepted by the U.S. construction industry.

A semiautomated rebar-tying device, designed at Massachusetts Institute of Technology (MIT), is a gunlike device that automatically adapts to the size of the connection to achieve the strongest and most efficient connection (Altobelli, February 1991). This technology, documented in a master's thesis, is a typical example of a system in its initial design stage.

Composite-connection technologies involve onsite automated welding of shear studs to structural floor members through the steel decking. After the concrete floor deck is placed and cured, the entire floor and structural assemblage is locked together, permitting shallower concrete floor-slab depths. An example of an automated shear-stud welding device is the Studmaster, developed at MIT. This device rolls along corrugated steel floor decking and welds steel shear studs through the decking to the structural steel beams at programmed intervals (Slocum and Ziegler, June 1990). MIT developed the prototype, and Illinois Tool Works (ITW) bought the rights and analyzed it for possible internal or commercial use. After failing to find possibilities for Studmaster, ITW sent the prototype and design back to MIT (Charles H. Helliwell, Research Associate for the Technology and Development Program, Center for Construction Research and Education, MIT, professional discussion, 18 May 1992 [hereafter referred to as "Helliwell, 18 May 1992]). As discussed earlier in Chapter 3 under "Technology Transfer of Concrete, Masonry, and Steel Construction Automation," this device will remain dormant in its current state until a company sees economic possibilities in it, or until a further development is conducted by academia, industry, or Government.

Advanced concrete forming technologies mainly involve slipform techniques for walls of building cores, faces of dams, and pavements. Slipforming for building cores or the faces of dams provides reusable concrete-forming surfaces that are continually raised while the concrete wall is being placed. This process increases productivity by allowing continual concrete placement. Interior work decks and exterior scaffolds allow placement of inserts, embedded items, and reinforcing steel. The process of placing, consolidating, and finishing concrete with this type of slipforming is similar to traditional concrete wall-placement techniques, except that the forms are continually moving, allowing only very narrow tolerances.

Currently, the most common slipforming process is pavement slipforming. This process is usually performed by a machine that consists of a short paving unit mounted within a long-base, multiple-purpose main machine frame, carried on four bogie-mounted crawler tracks. The slipforming machine moves over loosely placed concrete. It spreads, compacts, and finishes the concrete using a series of separate, individually adjustable elements within the paving unit (Walker and Beadle 1975). Miller Formless Systems Company has developed and uses several slipformers for pavement, curbs and gutters, sidewalks, bridge parapet walls, and barrier walls (Miller Formless Co. 1992). These machines can, while moving, adjust the extrusion shape to form road crowns or adapt to different slopes. Some slipforming machines can automatically insert steel dowels at the concrete slab joints, and either depress steel reinforcing mats (if used) into the previously placed concrete or insert them into the extruded concrete. This concept could lead to the development of a rebar-mat-inserting slipformer. Pavement slipforming is used often, but not exclusively. It differs from building core slipforming in that it changes the traditional construction process more—by performing the entire construction process within the slipform machine.

Precasting, both offsite and onsite, uses controlled conditions to produce building elements that can easily be erected onsite. Onsite precasting includes tilt-up construction of precast concrete walls. Precasting concrete has been done sporadically since the turn of the century, when Thomas Edison mass-produced eleven houses with it (*Concrete International*, October 1979). Modern precasting, developed by Shimizu Construction, is an integrated construction system that consists of precast concrete floor units, with shear keys cast into them, placed on precast concrete girders and beams. A layer of concrete is placed on top of the whole system, locking it together (Takada 1990).

A similar technique is used in the United States with precast concrete members and hollow-core floor units, on which a concrete topping is placed. Concrete precasting uses automation in a factory-like setting to best control the product, but it also requires better and more precise planning and site measurement.

Automated concrete placing devices, such as the Horizontal Concrete Distributor (HCD) produced by Takenaka Corp., transport concrete through a pump. The device uses a control system to monitor and control the placement of concrete. Control of the placement hose position may be manual, teleoperated, or programmed. Other companies that have developed similar machines are Kajima Corp., Ohbayashi Corp., and Fujita Corp. These machines are currently in use on construction sites in Japan, but have yet to be seen on U.S. construction sites. However, concrete pumps are often used in the United States. An example of these are truck-mounted concrete pumps by Putzmeister Maschinenwerke, which have not only been used for building construction, but have also been used to encapsulate the Unit 4 Reactor at Chernobyl (Meieran, April 1988). A similar device, which is available but not in wide use, is a robotic-arm conveyor system manufactured by Raider Reach Manufacturing, Ltd., of British Columbia, Canada. This device can transport concrete, sand, earth, aggregate, etc., but cannot perform tasks requiring an extended vertical reach (*Concrete Construction*, March 1992).

A placement technology for airfield runway repair has been developed and used by Foster-Miller, Inc. This system, the Binder Placement Unit (BPU) runway repair system, consists of a teleoperated truck-mounted pump that places rapid-setting polymeric material into a bed of prepared aggregate. The polymeric material, produced by the BPU, combines polymeric components from tanker trucks with the correct amount of catalyst for the ambient atmospheric conditions. The BPU runway repair system can repair craters as large as 60 ft in diameter (Foster-Miller 1992).

Automated concrete application technologies mechanize the shotcrete process, eliminating the worker's exposure to a hazardous condition. This technology is being used mostly in conjunction with the New Austrian Tunneling Method (NATM). This method involves tunneling through hard ground, mucking out the debris, and spraying a layer of shotcrete on the walls thin enough to allow the rock to establish a natural arch action. Rock bolts, and sometimes wire mesh, are then installed to secure large pieces of rock and provide shotcrete reinforcement. Finally, a second layer of shotcrete is sprayed on the walls (*Engineering News-Record*, 6 December 1984). Examples of automated shotcrete devices have been developed by Ohbayashi Gumi Corp., Mitsui Miike Seisakujo, Meynadier Corp., Kobe Steel, and Kajima Corp.

Shotcreting techniques are also used with soil-nailing and mining to create a fixed surface and prevent any local failures in the earth wall. A hydraulic, teleoperated shotcrete application device—Robocon—has been used for the high-strength, microsilica shotcreting of a U.S. Bureau of Mines experimental project in Pennsylvania (*Highway and Heavy Construction*, June 1984). Use of automated shotcreting for soil stabilization has been initiated in the United States, but is not yet used extensively.

Fujita Corp. has developed an automated device that applies a concrete layer against tunnel walls, similar to slipforming. This method produces less waste material than shotcreting, and does not create a hazardous area around the machine (Koga and Waku 1989).

The only fully automated concrete consolidation device, produced by Ohbayashi Corp., automates the control of concrete-form vibration in wall, beam, or column sections that are heavily reinforced and do not allow enough room for an immersible vibrator. Although this automated form concrete vibrator is used in Japan, it is not used by the U.S. construction industry.

Advanced finishing technologies for concrete construction automate screeding and finishing tasks for cast-in-place concrete slabs. Automated screeding machines typically consist of auger and tamper components, mounted on a computer-controlled mobile platform (Takenka Corp. 1988). The screeding

device can be mounted on a motor vehicle or girder. One of the first of these devices to emerge in the construction field was the automated concrete-slab finisher. This device generally is mounted on a computer-controlled mobile platform, and equipped with mechanical trowels that produce a smooth, flat surface (Takenka Corp. 1988). Companies in Japan that have developed and are currently using automated concrete screeds and finishers include Takenka Corp., Shimizu Corp., Kajima Corp., and Ohbayashi Gumi Corp. Although they are not seen often on U.S. construction sites, these technologies have been tested on some domestic construction sites. One example is FLATKN, Shimizu's concrete finisher, which was used during construction of the Sports Center of the University of Texas at Austin. The finishing test went fairly well, despite some problems with the pushbutton controller and strong local radio signals, which caused the radio-controlled device to malfunction (Cranmer and Tucker, November 1990). The same concrete finisher was also used on The University of Texas Balconies Research Center. The use of a similar concrete finisher was attempted during construction of J.C. Penney corporate headquarters in Dallas, but the device had control problems similar to FLATKN and was not used.

Some concrete finishers integrate a modular locomotion component and task-performing component. Modular design saves money because multiple locomotion components do not have to be developed and manufactured. It also saves on maintenance and repairs by making it easier to repair damaged components, rather than the whole system. Such systems have been developed and are currently in use on construction sites in Japan, but not on U.S. construction sites.

Masonry Construction Automation

Only a few masonry construction automation technologies have been developed. Table 3 lists the major ones. Appendix C includes drawings of some of the key technologies available. Many automated masonry construction projects aim at mechanizing a comprehensive masonry construction system. They automate the transportation of masonry pallets up to conveyors that lead to the block-laying area. The blocks travel on the conveyor to a block-laying arm that butters and places them (Malinovsky, et al. 1990).

Table 3

Current State of Masonry Automation Research, Development, and Technology

Title/application of equipment	University/Corporation conducting research	Dev. stage * (Intl)	Dev. stage (U.S.)
Masonry tasking	City University North Hampton Sq., London	D	-
Masonry robot complex	All Union Res. Inst. Moscow	D	-
Scara robot	Technical Research Center of Finland	D	-
Manipulator for block laying	Fraunhofer Inst. for Transport Eng.	D	-
Blockbot	MIT	-	P
Brickbot	University of Illinois at Urbana-Champaign	-	D
MAMA	IMI, USACERL, and contractor	-	P
Automated stone cutting	University of Maryland	-	D

* D = Design development stage

P = Prototype stage

I = Implementation by construction industry

A unique technology that alters conventional construction techniques for masonry assemblage is Blockbot, developed at MIT. This system, as designed, would dry-lay special low-tolerance bricks (Swedish Leca bricks) and use a surface-bonding technique (Surewall) to fix the wall as one unit. The system includes a manipulator arm mounted to a construction scissor lift, which is adapted to supply concrete masonry units to the manipulator arm (Slocum and Schena, April 1988). Blockbot is different from most masonry construction systems because it actually changes the construction process rather than just mechanizing it. Both dry-laying and mortarless bonding radically depart from conventional methods. The Blockbot system simplifies block placement, but adds another task for fixing the blocks in place. These changes in techniques would require new QA techniques for ensuring structural integrity of the masonry wall.

Blockbot, one of the first construction automation projects executed by MIT's Center for Construction Research and Education, was a proof-of-concept project that resulted in the development of the automated manipulator arm, but not the entire system (Helliwell, 18 May 1992).

Although Blockbot has not been fully developed, the idea of changing the construction process to address the problem of tolerances is being used in the development of another automated masonry-laying device. This research is being conducted by Ad Astra, Ltd., of New Mexico. In the search for a local market niche, and to find a construction technique that works well while requiring less precision, Ad Astra chose to automate adobe construction. The advantages of using adobe construction are increased allowable construction tolerances, lightweight materials, and an inexpensive bonding material (mud). Special mortars are not needed, and conventional surface plastering can cover any nonstructural wall imperfections. This improves on the Blockbot concept because the adobe-laying robot is a freestanding mobile robot that uses laser surveying techniques to position itself as it moves to different positions on the site, rather than needing tracks to position and guide it (Ray S. Leonard, Ad Astra, Ltd., professional discussion, 28 May 1992).

A USACE Construction Productivity Advancement Research (CPAR) project, the Mechatronically Assisted Mason's Aid (MAMA), is being conducted by the U.S. Army Construction Engineering Research Laboratories (USACERL), the International Masonry Institute (IMI), and a private-sector contractor. The goal of the project is to develop an automated device that helps the mason in lift, position, and set masonry units. An initial design concept includes masonry-unit gripper that is manipulated by the mason, and rides on a carriage unit that allows triaxial movement (Advanced Technologies Research, October 1990). Prototypes of MAMA components are now being developed.

An automated stone-cutting system for material production has been designed at the University of Maryland. The research was performed to demonstrate the feasibility of using flexible manufacturing techniques for the automation of stone-cutting. The system consists of a robotic arm, scale models of stone-handling equipment, fixtures and components, and custom-made stone-handling crates and pallets (Bernold, Renhart, and Livingston, February 1988).

Steel Construction Automation

Steel construction automation includes the categories of erection, connection, and construction systems. Table 4, lists the automated devices, the developer, and the stage of development. Appendix D includes drawings of some of the key steel-construction automation technologies discussed here.

Steel erection machine automation includes devices such as the Mighty Jack, developed by Shimizu Corp., which uses teleoperated clamps to grip and lift structural steel beams. When the beam is raised above the two columns it will connect, the setting assemblage is aligned and placed over the columns, to secure them. The beam, aligned with the setting assemblage, is lowered directly onto the column-tree beam extensions below it. Placement pins aid in alignment of the beam and holes in the beam projections of the column tree. After erection, the beams still have to be bolted or welded into place. Similar devices, such as Shimizu's Mighty Shackle Acc, are made for columns.

Table 4

Current State of Steel Automation Research, Development, and Technology

Title/application of equipment	University/Corporation conducting research	Dev. stage* (Intl)	Dev. stage (U.S.)
Mighty Jack	Shimizu	I	-
Mighty Shackle Ace	Shimizu	I	-
Autoclave	Ohbayashi Corp.	I	-
Autoclamp	Ohbayashi Corp.	I	-
Automated Crane Erection System (ACES)	Lehigh University	-	P
ATLSS Connection	Lehigh University Lafayette College	-	P

*D = Design development stage

P = Prototype stage

I = Implementation by construction industry

U.S. construction firms are not currently using Japanese structural erection technology, but the Lehigh University Center for Research on Advanced Technology for Large Structural Systems (ATLSS), with funding from the National Science Foundation (NSF), is developing a computer-controlled automated crane erection system (ACES) for steel construction using new structural connections. The erection system is a refined "Stewart Platform," which is a marionette-type manipulation device suspended from a tower or boom crane. It consists of two platforms, one below the other, suspended by six cables. A joystick allows the operator, on the platform just above the steel member, to pick up and place steel with high accuracy (Davis, December 1991).

Currently, the hardware has much more capability than the controlling software can use, but that will change as the software is upgraded. Developments expected for the platform include the incorporation of vision systems, a force-reflective joystick, and wind-resistance capability. Although the platform was originally developed for erecting structural steel, potential uses are expected in building facade erection (Perreira and Viscomi 1991).

Linked with the ATLSS system is the development of a structural connection to facilitate automated erection. This connection also is being developed by ATLSS with funding from NSF. The connection consists of a tapered piece of cast steel, mounted to a beam end, that slips into a sleeve attached to the column. Connection strength depends on the transfer load between the sloping vertical surfaces of the assemblage. The connections to the column and beam are to be made in a fabrication shop (Davis, December 1991).

At present, the connection is in its fifth generation of development, and has evolved into a moment-resisting connection so strong that load tests result in beam failure, not connection failure. Development is progressing rapidly. A patent for the connector has been applied for, and an unnamed progressive steel fabricator/erector is said to be interested in helping to fund, develop, and introduce it to the construction industry (N. Duke Perreira, assistant professor, Lehigh University Center for Manufacturing Systems Engineering, professional discussion, 19 May 1992). Because the connection is still being developed, erection and connection specifications have not yet been developed.

Comprehensive Automated Building Systems

Comprehensive construction automation systems use automated devices from various construction categories to achieve a whole new construction process. Table 5, lists current systems, their developers, and their stage of development. Appendix E includes drawings of two key systems.

A concept common to these systems is the idea of bringing the factory to the site or, in some cases, developing the site as a factory. The most comprehensive and innovative system developed to date is the Shimizu Manufacturing System by Advanced Robotic Technology (SMART) by Shimizu. The construction process begins with the excavation for foundations or a basement. Next, the building's top floor is erected at ground level, and mounted on jacking towers located inside the building's perimeter. Control rooms occupy this floor, for controlling cranes and winches that hang from a structural gridwork below the floor.

After the control room floor is complete, it is jacked up one level, and construction of the first floor takes place. After this, the top floor is jacked up another story and the second floor is constructed. The process repeats until all floors are erected. As the floors are built, so is a protective enclosure around the exterior of the building. This protects the construction process from the weather. After the building is complete, the control room components are removed by cranes. This system automates the erection and welding of the steel frame, the placement of precast concrete floor planks, and exterior and interior wall panels (*Engineering News-Record*, 11 November 1991). Through automation of the total construction process, this system attempts to replace the human worker on the construction site.

A prototype of the building's jacking towers has been manufactured and successfully tested. The first project it has been used on, the Juroku Nagoya Bank Building in Nagoya, Japan, broke ground in October 1991. By June or July 1992, the construction of the control room was started. The 20-story building is expected to be finished by December 1993 (*Shimizu news release*, 16 October 1991).

Another comprehensive building system that brings the factory to the construction site is the Automatic Building Machine (ABM), developed by MIC Industries. This system has been tested and used on agricultural, commercial, industrial, military, aerospace, recreational, and institutional buildings throughout the world. The system was also used for the construction of temporary facilities during Operation Desert Storm. From a spool of galvanized sheet metal, the system forms lockable segments of a Quonset hut at the site. These segments are locked together with an automatic seamer to form larger segments. The large segments are lifted into place by crane and set down on a previously erected concrete foundation framework. Specifically, the segments are placed into and braced against a steel angle, which is welded to steel reinforcing bars that extend vertically from the concrete foundation framework. The seamed segments are joined to other large segments by the automatic seamer riding the seam from one side of the Quonset hut to the other. After the roof is completed, the end walls are lifted into place and

Table 5

Current State of Comprehensive Automated Building Systems

Title/application of equipment	University/Corporation conducting research	Dev. stage* (Intl)	Dev. stage (U.S.)
SMART	Shimizu Corp.	P	-
ABM	MIC Industries	-	I

*D = Design development stage

P = Prototype stage

I = Implementation by construction industry

seamed under the roof edge (and to the steel-reinforced door frame). Finally, the foundation around the edge is finished, and the grounds are landscaped. A structure built by the ABM can later be disassembled and used again (MIC Industries 1992). One aspect that must be addressed is construction specifications governing aspects such as how many times an element may be re-seamed.

Construction Automation Trends

Definition of "Trend"

As discussed previously, the driver of most developments in the construction industry is cost, both in terms of productivity and potential liability. If a new device does a task correctly, has a significantly lower net cost than conventional methods, and creates no new safety or legal liabilities for the user, the technology will tend to be used and accepted onsite. In this report, automation technologies that meet those three criteria and are rapidly being accepted on the construction site are considered trends. If a technology is only in its initial design stages, or represents a proof-of-concept project that did not develop to maturity, it is not considered a trend. Table 6 summarizes the key trends in all areas of construction discussed on the following pages.

It is assumed that all causes for the failure of technology transfer and adoption will remain much the same over the next 15 years. If any of the disincentives to construction technology innovation are removed or reduced, some of the projections would have to be revisited.

Trends in Sitework Automation

The cost incentives (and barriers) behind construction innovation are intensified simply by the nature of sitework construction. It is an equipment-intensive art, usually not considered "construction" by the public because much of it does not appear to produce a built portion of the project.

Considering that the technology transfer duration for sitework construction is about 10 years and the status-prediction window for this study is 15 years, one would expect that most of the sitework automation devices discussed here would be in general use before 15 years have passed. However, for the great majority of these devices to be used on USACE projects, current USACE construction contract provisions would have to be modified, putting responsibility for the site survey and layout on the contractor. If the site survey and layout continue to be performed by the Government contractors will have very little incentive to use automated sitework.

It will be assumed for purposes of status prediction that, within 15 years, USACE contract provisions will transfer site survey and layout responsibility to the contractor. If current USACE contract provisions remain the same or other conditions arise, the following projections may be invalid.

Trends in Automated Surveying. As discussed previously, surveying automation addresses site metrology and site investigation. Site metrology uses laser transits simply apply improved technology to boost site efficiency (e.g., compensating for atmospheric conditions). An example is the "Top Gun total station," made by Nikon. Laser transit surveying is already being used on USACE construction projects.

Automated site metrology also employs differential GPS. This technology alters the conventional surveying process by eliminating all checks on the quality of the data produced. The U.S. construction industry has accepted GPS surveying, but it is not yet regularly used on sites. This is probably due to the current cost of the technology. However, like computers and other forms of high technology, the GPS receivers are steadily decreasing in cost, which will make them a logical alternative to current conventional surveying techniques.

Table 6

Summary of Current Construction Automation Trends

CONSTRUCTION CATEGORY	TREND	EXAMPLE	WITHIN 15 YEARS
Sitework			
Surveying & site layout	Better machine	GPS surveying	YES
Site investigation	Better machine, replace the worker	Autonomous pipe mapping	YES
Excavation	Better machine	Rapid runway repair robot	YES
Trenching	Better machine	CASTEC system	YES
Tunneling	Better machine	Automated tunneling	YES
Trenchless construction	Change the process	Pipe-jacking Microtunneling	YES
Grading	Better machine	Spectra-Physics	YES
Compaction	Better machine	Fujita Corp. compactor	YES
Dredging	Better machine	IHI automated dredging ship	YES
Concrete			
Reinforcement	Replace the worker	Prefab Rebar Units	YES
Composite Connections	Replace/assist the worker	Studmaster	YES
Slipforming	Change the process to increase productivity	Miller Formless	YES
Precasting	Change the process to increase productivity	Integrated constr. method	YES
Placement	Improved tools	HCD	YES
Application	Better/safer machine	Shotcrete robot	YES
Consolidation	Replace/assist the worker	Automatic conc. vibrator	NO
Finishing	Replace the worker	Surf Robo	YES
Masonry			
	Replace the worker	Robot brick complex	NO
	Change the process & materials	Blockbot	NO
	Improved tools	MAMA	YES
Steel			
	Improved tools	Mighty Jack	NO
	Change the process & materials	ACES	YES
Comprehensive building systems			
	Integration of automated subtasks & replacement of the field worker	SMART	NO
	Change the process	ABM	YES

Automated site investigation employs advanced sensing mechanisms that eliminate the labor-intensive aspect of conventional site-investigation techniques. These systems, controlled remotely or programmed, allow safe sensing and mapping of hazardous environments. The main objective of this technology is to relieve the worker of tedious or hazardous surveying tasks. The progress of automated devices with integrated position-sensing and locomotion technologies indicates that automated site-investigation systems will be adopted on U.S. construction sites within the next 15 years. These machines would be used during initial project feasibility and design studies.

Trends in Automated Earthworks. Earthwork automation technology trends are evident in the categories of excavation, tunneling, grading and compaction, and dredging. The trend in excavation automation is toward devices that improve productivity and accuracy, and enable remote or programmed excavation in hazardous environments. One example is the RRR excavator, which uses interchangeable tools to excavate and repair runways through remote or programmed control. Other technologies being

developed include terrain-adaptive excavation and computer control systems. Terrain-adaptive excavation, being developed by the University of Whales, England, adjusts its digging style to fit the soil type. Computer control systems which determine the excavation depth are still in the development stage.

Automated excavation integrates the site layout with the excavation process. Although excavation with automated devices improves efficiency, the basic process remains the same. Considering the R&D terrain-adaptive excavation and computer control systems should be seen on U.S. construction sites within the next 15 years.

Automated trenching devices also provide increased construction productivity. Systems now available include the CASTEC system, the SSS-G, and the High-Speed Excavator. The CASTEC system automatically digs trenches for foundation work, utilities, retaining walls, dam cutoff walls, and water-seepage control walls. Concrete can be placed simultaneously with the use of this machine. The SSS-G excavates for large substructures such as dams, underground storage tanks, and bridge and pier foundations. The High-Speed Excavator is used by the Army for digging a wide variety of combat emplacements and trenches, from 2 ft to 12 ft wide. All of these systems allow better excavation control, and are currently being used in the United States and worldwide.

Tunneling automation increases productivity through increased automation of conventional mechanical moles or the preprogrammed and automated drilling and placement of explosive charges for tunneling through rock. Both types of systems have been developed and are currently in use in the United States and worldwide.

Trenchless construction techniques eliminate conventional trenching practices by using a hidden, integrated excavation and construction process. This has radically altered traditional pipe and cable-laying processes. The use of trenchless technologies has been increasing on U.S. sites, and will continue to increase over the next 15 years as it becomes necessary to build in areas where trenching is expensive, difficult, or impossible.

Automated grading eliminates the site layout process. Time and money are saved by not having to perform a site layout. However, it results in reduced inspection efficiency because, before checking the elevations and locations of earth placement, a site layout must be performed. Using GPS as a grading positioning tool requires a stationary GPS benchmark and a mobile field receiver on the grader cutting blade. This would eliminate the need to survey the site and manually set up the benchmark.

The implementation of GPS-based automated grading would make established USACE QA inspection techniques inefficient, but not impossible. Because of the use and acceptance of automated grading, the popularity and the quick development of GPS systems, and the short technology transfer duration for sitework construction, a GPS-based automated grading system can be expected to be used regularly on U.S. construction sites within fifteen years.

Dredging automation increases efficiency and accuracy through mechanization of much of the suction dredging process. These systems automate the processes of controlling dredge depth, determining location, and assuring the correct dredged-material concentration, flow, and hopper load. Most of this automation simply improves ways to perform the conventional dredging process. The use of GPS for dredge positioning and control eliminates the need for the shore and water "site layout," which are used to continuously check the dredging process. A GPS receiver is used on the shore for the "benchmark" and a field receiver on the ship for continuous real-time measurement of the ship's position in relation to the dredge level. It provides a more efficient and accurate dredging procedure.

Concrete Construction Automation Trends

Machine automation trends are evident in the areas of reinforcement, forming, placement, application, and finishing. The basic trend for steel reinforcement automation is to increase productivity

by replacing or assisting the laborer. Kajima Corp.'s rebar-placing machine replaces the laborers usually required to place one reinforcement bar (although one worker is needed to control the forklift). Within the next 15 years, this device could either be accepted by the U.S. construction industry or independently developed, implemented, and accepted by the U.S. construction industry.

The prefabricated rebar-assembling devices replace the worker completely, except during CAD input of the reinforcement design and monitoring of the assembling equipment. Considering this technology's current acceptance in Japan, and its substantial improvement of construction productivity by performing the tedious alignment and tying tasks, it will probably be seen on U.S. construction sites within 15 years. The technology replaces many workers and improves efficiency through automation, but does not fundamentally alter conventional processes.

The Semiautomated Rebar Tying device is similar to the technology used in rebar-unit assembly plants, but it is not programmed to position itself onsite. It must be positioned and operated by a laborer. This device might be seen 15 years from now on U.S. construction sites, but only in limited use because prefabricated rebar units will probably be widely used for greater cost savings. This illustrates a point made previously: that if the costs savings of an automated device do not outweigh acquisition and system maintenance costs, the device will not be used.

The overall trend for concrete-reinforcing technologies is to replace the laborer with a machine that can perform the task faster and with greater accuracy.

Composite-connection assemblage technologies, such as Studmaster, automate the welding of steel shear studs to structural floor members through steel decking. The conventional process of welding shear studs to metal decking requires a worker to bend over and weld the studs with a stud-welding gun at specified locations. The goal of these technologies is to relieve the laborer of tedious, repetitious, and fatiguing tasks. Automated shear-stud welding is likely to gain acceptance at U.S. construction sites over the next 15 years, considering the current state of the technology and the tedious, physically stressful activity it replaces.

The trend in automated slipforming is to transform concrete casting into a continuous process to increase efficiency and productivity. Automated slipforming eliminates much labor for workers, who normally have to construct and remove each set of forms separately. Labor costs tend to account for half of the cost of concrete construction.

Vertical slipforming changes conventional construction procedures somewhat by being semicontinuous and requiring extremely tight tolerances. Horizontal (pavement) slipforming changes the construction process in two distinct ways.

First, concrete is formed using moving forms (rather than fixed ones). This eliminates the inspector's opportunity to ensure the level, location, and configuration of the forms. In conventional concrete slab construction, this aspect of quality is ensured through inspection of formwork alignment. Then, when the concrete is placed, correct slab depth and configuration are ensured.

Second, automated concrete slipforming accomplishes many standard, manual tasks such as reinforcing wire and tie dowel placement, concrete consolidation and screeding—previously open to inspection—within the machine itself. Therefore, during automated slipforming, real-time visual inspection or acceptance is not possible, so immediate corrective measures cannot be taken. Based on the current state of slipforming automation and its potential benefits, the technology is likely to be used much more in the future—especially for pavement slipforming.

The use of precast concrete alters the way in which concrete is typically handled, manipulated, and attached to a structure. Essentially, concrete is precast to move the labor-intensive casting process to a factory, or at least onto the ground, where productivity can be much greater than in the air—and the

ground can serve as part of the form. Precast concrete is, in a sense, a unit of stone, and is attached to the structure and inspected similarly. Precast concrete has been used in the past and will be used in the future to improve worksite efficiency.

The trend in concrete placement is to use automation to place concrete faster, and with fewer people, exactly where it is needed. In essence, the devices are simply better machines that improve concrete-delivery methods to save money in labor, time, and material waste. Automated concrete distributors have been developed in Japan, and in the next 15 years they may be accepted by the U.S. construction industry. At the present time, however, the concrete-placement needs of domestic construction firms are met by a concrete bucket, buggy, or a simple concrete pump—at much less expense than an advanced concrete distributor.

Automation trends for concrete application simply involve automating the shotcrete process to replace the human worker in a hazardous situation, especially in enclosed spaces such as tunnels. Another application being developed is for soil stability during a soil-retention procedure (such as soil nailing) during excavation of a building's substructure or hillside roadway cut-and-fill operation. Automated shotcreting may be used by USACE within 15 years for tunneling applications and special hazardous-waste remediation techniques. One such development involves entombing hazardous waste in place with concrete by tunneling beneath the waste, and filling it with concrete to create a vault floor.

The trend in concrete-finishing automation is to relieve the laborer of the highly repetitive and tedious nature of concrete finishing. For this reason, and because it was one of the first successful and practical automated construction technologies, it is now being tested on U.S. construction projects. Implementation and acceptance is expected to continue and, given the average time it takes for industry to accept a new construction automation technology, concrete-finishing automation should be coming on U.S. construction projects within 15 years.

Masonry Construction Automation Trends

One important trend in masonry construction automation involves designing a comprehensive bricklaying system that incorporates cranes to lift brick pallets to storage areas that feed a conveyor. This system mainly mechanizes conventional bricklaying tasks to replace the laborer and increase overall productivity. There are three reasons why these technologies will not be adopted by the U.S. construction industry within the next 15 years. First, these systems are only in their initial design stages, and only if the construction industry saw great benefits in them would the systems be accepted within 15 years. Second, the systems replace bricklayers, and people will not support a technology designed to replace them on the job. This resistance by labor will definitely prevent the systems from being accepted within 15 years. Third, these automated systems do not address problems in masonry construction that led to the investigation of Blockbot, the MIT mortarless block-bonding technology described earlier. A problem inherent in automated bricklaying is uniform mortar application and block placement to ensure level blocks and "true" walls. This problem influenced MIT to investigate dry-laying of the masonry units, and led to the realization that common masonry units vary greatly in size—far too much to support a precision automated bricklaying system.

Another important trend in automating masonry construction is addressing the tolerance problem inherent in standard masonry units. This requires taking a different approach both to construction materials and methods. Both MIT's Blockbot and Ad Astra's adobe construction robot are examples of nonconventional approaches. Although never fully developed, Blockbot introduced the idea of altering construction processes and materials to meet the tight tolerances necessary for automated bricklaying. This idea is continued in the adobe construction robot, but Ad Astra has modified the construction method so stringent dimensional tolerances are not required. Because development of Blockbot has ceased and the adobe robot is still in its design development stages, neither technology should be expected in common use on the U.S. jobsite within the next 15 years.

One other masonry automating trend uses a machine to help the mason handle heavy materials and to reduce the chance of related back injuries. One example of this trend is MAMA, discussed previously, which is partially funded by, and has received design input from, the IMI. IMI's involvement should facilitate transfer and acceptance of this technology to the U.S. construction industry. Because MAMA is well into its prototype phase, it should be common on the job site within 15 years.

Steel Construction Automation Trends

The major trends in steel construction automation also are to replace or assist the laborer to increase productivity. These trends are evident in both the steel erection and connection areas. Steel erection and connection have not been addressed in an integrated way to date. Although Shimizu Corp. has developed a lifting and setting system, that system cannot connect the structural members. Therefore, workers must climb the structural frame to secure the connections soon after placement. In addition to this, the whole setting assemblage must slide over and around the flange of a column to align itself so it can place the beam. Teleoperation of this system by a worker on the ground is difficult. For these reasons, the Shimizu device probably will not be used widely in the United States within the next 15 years. A more important reason is that more comprehensive systems are being developed the United States.

Lehigh University's beam-connection design for automated assembly, used in conjunction with its automated system ACES, represents a comprehensive automated steel construction system. This involves the erection of a steel beam carried directly below a maneuverable operator's deck. This operation can be performed by ACES with a great deal of accuracy. Also, the keyed connection used by the system may eliminate the need for another connection after placement. (Presently, however, a bolt is attached after the plumbing process.) This system was developed to enhance steel placement productivity by putting the operator closer to the steel member and removing other workers from dangerous heights during connection. Because this technology is in its final prototype stages, and a progressive steel-construction firm is interested in it, the technology should be in use on U.S. construction sites within 15 years.

This innovation, along with work in automated masonry construction, illustrates that automation is facilitated when material properties or construction techniques are modified to take into account machine limitations. This indicates that joint efforts between material suppliers, contractors, and equipment suppliers would accelerate the process of automating construction. The Stewart Platform component of ACES, now in its early prototype stages may yet be used on some U.S. construction sites within 15 years.

Comprehensive Automated Building System Trends

One important overall trend is to integrate the automation of most or all tasks within a specific construction process. In one such technology, an early prototype of which is now being developed in Japan, the final vision is to enable workers to monitor the entire construction process from a remote control facility. Such systems would radically change current construction processes, and their implementation would essentially change the entire construction industry. This, combined with the U.S. construction industry's expected resistance to technology that would fundamentally change the way it does business, virtually guarantees that such systems will not be in widespread use in the United States within 15 years.

Another type of the comprehensive building system, the ABM, is being used for various types of construction. It simplifies the construction of Quonset huts for instance, by "bringing the factory to the construction site" to save money and eliminate lead time required for factory-prefabricated components. This trend may continue to develop in technical sophistication as the capability and portability of machines increase. The ABM is currently being used in military, residential, institutional, commercial, and recreational construction throughout the world.

4 LIKELY EFFECTS OF AUTOMATION ON USACE QUALITY ASSURANCE

Changes in Materials and Processes vs Changes in Tools

Real changes in construction materials and processes—not tools—will tend to require the development of new QA techniques. The construction automation trends discussed earlier will be evaluated here to determine whether they represent a change in construction materials or processes or simply a change in the tool. This will indicate which automation technologies are likely to affect established USACE QA practices.

Automation Effects on Sitework QA

Surveying automation—both site metrology and site investigation—involve improvements in the construction tool. An example is the total station system, which only expedites the surveying process. Automated site investigation involves the removal of the laborer from the site investigation process to avoid tedium or hazardous environments. The system that improves the surveying efficiency the most—especially for remote areas—is GPS surveying. This system, which is accepted and used today, eliminates the need for using conventional benchmarks (i.e., building corners, curbs, etc.). But because these devices represent improvements in tools, not processes, they will not require any new QA practices. Actually, many improvements in surveying and other sitework tasks enhance conventional QA techniques by providing a much more reliable and repeatable way to determine positions, eliminating much of the potential for human error.

Automated excavation uses an electronic, nonvisual positioning system. Traditional QA requires periodic inspection of positioning and depth through cross-referencing against the site layout. These systems can eliminate the need for a site layout, making conventional QA techniques for positioning and depth inspection inefficient. Conventional QA would work, but it would be more costly to complete.

Automated trenching and tunneling represent improvements of conventional tools, but do not significantly expedite the conventional processes. Therefore, USACE QA techniques should not be affected.

Trenchless construction techniques eliminate the cost of excavating and shoring utility trenches, reduce disturbances on grade, and remove the worker from potentially hazardous environments. Trenchless construction alters traditional construction processes by performing the construction activities underground, out of sight of QA inspectors, who rely on visual inspection and direct measurements. Therefore, new USACE QA techniques are needed to verify the *in situ* quality and placement of underground utilities placed by trenchless techniques.

Automated grading improves construction productivity in the same manner as automated excavation—through the use of positioning technologies that eliminate the need for traditional ones. The two leading technologies for controlling blade height are rotating laser and GPS systems. Without the site layout process, the inspector must check grading location and depth using traditional surveying methods. However, the check will be inefficient.

Compaction technologies, mainly used in Japan, use remotely controlled compactors in mass compaction efforts, such as dam and highway embankments. These machines remove humans from the time-consuming task. This technology is essentially an improvement of the conventional construction tool, so conventional compaction QA techniques can still be used.

Automated dredging systems improve conventional tools to improve soil extraction and positioning. As for automated excavation and grading, conventional surveying methods can be used to verify quality, so new USACE QA practices are not required.

Automation Effects on Concrete Construction QA

Most automation for concrete construction involves the improvement of conventional tools. Automation of steel reinforcement placement and tying both involve replacing manual labor with an automated tool, but do not change the construction process. Therefore, no new QA techniques are required.

Wall slipforming automation also affects the tool, not the overall process. Building core or wall slipforming differs from the conventional process of constructing concrete walls in that the forming is semicontinuous. This requires tighter tolerances, but does not change the typical casting process: all insert placement, embedment placement, and concrete consolidation are performed manually. Because the basic process is not changed, established USACE QA methods are not affected.

Automated pavement slipforming, on the other hand, is quite different from the conventional process because machines automatically perform many tasks out of the sight of the workers and QA inspectors. These tasks include insertion of the reinforcing dowels that connect the concrete slabs to the steel mesh reinforcing mats. These reinforcing mats are automatically placed within the concrete as it is extruded from the machine, or depressed into previously spread concrete. This application may lead to automatic insertion of prefabricated rebar mats. Consolidation is done with plate vibrators or immersible vibrators before the concrete is extruded under the slipformer's rear pan. In addition to this, conventional slab construction allows form height and layout to be checked, thereby ensuring slab height and layout, but automated pavement slipforming eliminates these checks, so product quality depends on a moving assemblage. Because automated pavement slipforming changes the construction process by preventing the inspection tasks that assure quality, this technology will require USACE to develop new QA techniques.

Precasting involves a slight alteration of the construction process to achieve better quality and construction productivity. Although the process is changed, the resulting masonry unit can be handled as if it were a piece of stone. Because the results of the automated process can still be inspected by conventional means, no new USACE QA practices are required.

Automated concrete-placement systems improve on previous concrete systems by more accurately measuring and distributing specified amounts of concrete on the site. The mode of concrete transportation has changed, but the concrete still ends up at the same destination, and can be checked before placement by established USACE QA practices.

Automated concrete-application technologies, such as automated shotcrete systems, essentially represent improved tools that allow the worker to avoid hazardous work conditions. These systems will not affect established USACE QA practices.

The various automated concrete-finishing technologies starting to be tested in the United States effectively improve conventional tools by enabling the tool to perform a very tedious task in place of a laborer. The conventional finishing process is not altered, so QA practices are not affected.

Automation Effects on Masonry Construction QA

One trend in masonry construction automation improves conventional tools by assisting or replacing the worker in lifting and setting masonry units. Examples include many European block systems and MAMA. This technology will not affect USACE QA practices because it simply supplements or replaces human labor with mechanized tools.

An emerging trend modifies construction processes and materials to help meet the tight construction tolerances required by automated bricklaying systems. Examples are MIT's Blockbot and the adobe construction robot now being developed. Because these technologies change both processes and materials,

new QA practices must be developed. However, these technologies are not developed enough to be used widely within 15 years. Therefore, there is no immediate need to consider updating the USACE QA practices that ultimately would be affected.

Automation Effects on Steel Construction QA

Most steel construction automation trends appear as improvements of the construction tool. The Autoclaw and Autoclamp, developed by Ohbayashi, and the Mighty Jack and Mighty Shackle Ace, developed by Shimizu Corp., improve conventional crane and cable technologies by using teleoperated clamps to automatically release structural members, rather than requiring a worker to climb out onto the member and unhook the cable. (However, an ironworker must still climb up to the connection to secure it.) These devices do not significantly change the process of placing structural members, so established QA practices will not be affected.

One automated steel construction system that does change construction processes is ACES, the automated crane being developed by Lehigh University. This system changes the construction process by replacing conventional welded and bolted connections with a beam keyed to fit a slotted column. This technology is rapidly emerging and is starting to get industry support. It appears that the system will be accepted at U.S. worksites within 15 years. Because this system substantially changes steel erection processes, USACE QA techniques and construction specifications will have to be developed to ensure the new connection's *in situ* strength.

QA Implications for Comprehensive Automated Building Systems

The goal of comprehensive automated building systems such as Shimizu's SMART system is to integrate all construction subtasks into a single automated process. From one point of view, such systems are just a conglomeration of improved automated tools (e.g., Mighty Jack, Mighty Shackle Ace, etc.). However, the entire system of individual tools is controlled and monitored from a single control room at the building's roof level. When fully developed, such systems would eliminate virtually all direct human contact with the actual construction task. The workers would be "telepresent" only, controlling the construction process remotely. An entirely revised or new set of construction QA practices would have to be developed to evaluate quality after construction is completed. However, the factorylike nature of a construction site using a comprehensive automated building system would allow the application of many established manufacturing QA techniques. However, because this technology is at a very early developmental prototype stage in Japan, such systems are not likely to be seen on U.S. construction sites in the next 15 years. Therefore, the potential changes fall outside of the time frame of concern specified in the objective of this report.

Other comprehensive automated building systems apply integrated technologies to more specific applications. The ABM, for example, substantially changes the conventional construction process for Quonset huts by automating onsite building-component manufacturing, connection of the components into units, and assembling the units into a completed building. One element of the system that differs greatly from the conventional Quonset hut is the seam developed to connect the building components. This seam runs across the entire arc of the Quonset hut, and is automatically secured by the ABM. Another difference is that the components used by the ABM do not rely on a structural frame, so every component must be structurally independent and sound. Because this system completely changed the conventional Quonset hut construction process and is already being used in the field, new USACE construction specifications and QA practices will certainly be needed over the next 15 years to ensure the quality of the structure.

5 SUMMARY AND RECOMMENDATIONS

Summary

Because USACE QA processes are affected mostly by changes in construction materials and processes, but not tools, only construction automation systems that significantly alter materials or processes will require changes in established USACE QA practices.

Most existing and emerging automated sitework technologies are basically improved construction tools that do not significantly alter conventional sitework processes. One exception to this trend is trenchless construction for the placement of new or refurbished underground utility systems. Because trenchless excavation is performed underground, it prevents QA inspectors from visually verifying the excavation's final elevation and location. New QA techniques should be developed to ensure the correct elevation, location, and quality of utility installation.

Most current and emerging concrete, masonry, and steel construction automation technologies will not affect established USACE QA practices. There are a few exceptions, however.

Current USACE QA techniques cannot ensure the *in situ* quality of slipformed concrete construction because they rely on visual verification of preconstruction product-control measures and the construction process. Slipforming product controls (e.g., depth control) are performed automatically within the machine as are many of the construction tasks. Specific automated tasks that current USACE QA practices cannot adequately inspect and verify include *in situ* steel reinforcement and dowel placement, concrete consolidation, and concrete slab depth control.

Lehigh University's automated steel erection crane, ACES, uses a new method to connect beams to columns. If the system is adopted by the construction industry in the next 15 years, USACE will need to develop new QA practices and specifications to ensure *in situ* connection strength. One other emerging construction automation technology must be acknowledged by USACE: comprehensive automated building systems. Both examples discussed in this report—SMART and ABM—will require USACE to develop new construction specifications. SMART will radically alter conventional construction processes, but is not expected on U.S. construction sites within the 15-year time frame covered by this report. ABM, which is currently in use to automate the construction of Quonset huts, will require modified QA practices. However, USACE may be able to adapt QA techniques from the manufacturing sector.

Recommendations

It is recommended that:

- Nondestructive evaluation (NDE) technologies in general be investigated for possible use in new USACE QA techniques that will be required in some areas of automated construction. (Appendix F contains references and brief descriptions of candidate technologies.)
 - USACE investigate magnetic sensing and ground-penetrating radar as QA tools for ensuring the quality of automated steel reinforcement and dowel placement.
 - Acoustic impact and ultrasonic pulse-echo be investigated to ensure proper consolidation of concrete placed by automated systems.
 - Ultrasonic pulse-echo be investigated as a technique to ensure proper concrete thickness.

- USACE develop construction specifications rather than new QA practices for ACES and ABM. These automated systems will not require new QA techniques because conventional methods, such as visual inspection, can be used to ensure quality. However, construction specifications for ACES should ensure the field connection's shear strength and moment resistance. Construction specifications for ABM should ensure (1) the strength of the site-formed building segments, (2) the seam and reseat strength, and water infiltration resilience, and (3) the building's attachment to the foundation.

REFERENCES

- Alexander, Michael A., *Nondestructive Testing of Concrete with Ultrasonic Pulse-echo*, REMR Technical Note CS-ES-1.10 (1991).
- Allen, Edward, *Fundamentals of Building Construction Materials and Methods*, (John Wiley and Sons, 1985).
- Altobelli, Frank R., *An Innovative Technology in Concrete Construction: Semiautomated Rebar Tying*, Thesis for partial fulfillment of the requirements for the degree of Master of Science in Civil Engineering, MIT (20 February 1991).
- Baecher, Gregory B., *Estimating Depth of Cut from Blade Forces on Army Counter-Obstacle Vehicle*, Technical Report [TR] P-88/11/ADA195327 (U.S. Army Construction Engineering Research Laboratories [USACERL], April 1988).
- Barry, B. Austin, *Construction Measurements* (John Wiley and Sons, 1973), Chapters 9 and 10.
- Beliveau, Yvan J., "3-D Positioning for Construction Surveying and Automation," *Preparing for Construction in the 21st Century* (American Society of Civil Engineers [ASCE], April 1991), pp 656-661.
- Bernold, L., Davis Renhart, and Eric Livingston, "Automation of Stone Cutting," *Automated Construction Systems: Summary of Research Projects* (February 1988).
- Bernold, Leonhard, "Laboratory and Field Research in Construction Automation," *Preparing for Construction in the 21st Century* (ASCE, April 1991), pp 216-221.
- Bracewell, R.H., D.A. Bradley, R.V. Chaplin, and D.W. Seward, "Control System Design for a Robotic Backhoe," *Proceedings of the Seventh International Symposium on Automation and Robotics in Construction* (June 1990), pp 222-229.
- Brotherton, M., *Masers and Lasers* (McGraw-Hill, 1964), pp 199-201.
- Bullock, Darcy M., Sudheer M. Apte, and Irving J. Oppenheim, "Force and Geometry Constraints in Robot Excavation," *Engineering Construction, and Operations in Space II, Vol 2* (ASCE, 1990), pp 960-969.
- "Cable-Laying Job in Rockies Tests Tractors, Plows," *Highway and Heavy Construction* (November 1987), pp 60-61.
- "Channel Tunnel Gets Well Sprayed," *Tunnels and Tunneling* (July 1989), p 61.
- Clemena, Gerardo G., Michael M. Sprinkel, and Robert R. Long, Jr., "Use of Ground-Penetrating Radar for Detecting Voids Under a Jointed Concrete Pavement," *Transportation Research Record, 1109* (1987), pp 1-10.
- Clifton, James R., Nicholas J. Carino, and Paul Howdyshell, *In-Place Nondestructive Evaluation Methods for QA of Building Materials*, TR M-305/ADA112869 (USACERL, March 1982).
- Crane, Carl D. and Allen Nease, "Development of an Autonomous Excavator System for Remote Applications," *Proceedings of the 38th Conference on Remote Systems Technology* (1990), pp 186-187.
- Cranmer, Lee R. and Richard L. Tucker, "Operational Test and Evaluation of Automated Construction Devices," *Construction Industry Institute [CII] Technical Report* (November 1990).
- Cutler, Robert S., "A Survey of High-Technology Transfer Practices in Japan and in the United States," *Interfaces* (November-December 1989), pp 67-77.
- Davis, Virginia Kent, "Forging New Connections," *Engineering News-Record* (16 December 1991), pp 24-25.
- Eagle-Picher, corporate marketing literature (1992).

Eng, Paul M. and Amy Borrus, "Who Knows Where You Are? The Satellite Knows," *Business Week* (10 February 1992).

Foster-Miller, Inc., corporate marketing literature (1992).

Foster-Miller, Inc., "EPRI Pole Hole Drilling System," *Heavy Equipment Design*, corporate marketing literature (1992).

Foster-Miller, Inc., "Excavation Equipment Design," corporate marketing literature (1992).

Foster-Miller, Inc., "High Speed Excavator," *Excavation Equipment Design*, corporate marketing literature (1992).

Foster-Miller, Inc., "Mini Mucker," *Remote Control Vehicles*, corporate marketing literature (1992).

Foster-Miller, Inc., "Overburden Excavator," *Excavation Equipment Design*, corporate marketing literature (1992).

Fujita Corp., *Automation and Robotization for Construction Technologies*, corporate marketing literature (1988).

Fujita Corp., corporate marketing literature (1988).

Fujita Corp., "Onsite Welding Robot System," *Automation and Robotization for Construction Technologies*, corporate marketing literature.

Gatton, Thomas M. and Frank Kearney, "Automation and Robotics Research and Development," TR M-90/03/ADA214170 (USACERL, October 1989).

Ghosh, Shri S., "Dredging and Its Instruments," *IE (I) Journal-MA* (November 1987), pp 7-11.

Green, Peter, "Highway Paving Takes an Upswing," *Engineering News-Record* (13 January 1992), pp 29-30.

Gren, Gail G., "Hydraulic Dredges, Including Boosters," *Proceedings of the Specialty Conference on Dredging and Its Environmental Effects* (1976), pp 115-124.

Groover, Mikell, N. Duke Perreira, Cemal Doydum, and Richard Smith, "A Survey of Robotics Technology in Construction," *SME Technical Paper* MS89-271.

Halpin, Daniel W., "International Competition in Construction Technology," *Journal of Professional Issues in Engineering* (October 1990), pp 351-359.

Hasegawa, Yukio, "Robotization of Reinforced Concrete Building Construction in Japan," CAD and Robotics in Architecture and Construction, *Proceedings of the Joint International Conference at Marseilles* (25-27 June 1986).

"High-strength Shotcrete Demonstrated Successfully," *Highway and Heavy Construction* (June 1984), pp 62-63.

Hurn, Jeff, *GPS: A Guide to the Next Utility* (Trimble Navigation Ltd., 1989).

Kajima Corp., *Construction Robot/Automation Technology*, corporate marketing literature (1988).

Kajima Corp., *Robot for Arranging Heavy Steel Reinforcing Bars*, corporate marketing literature (1988).

Koga, Shigetoshi and Akimasa Waku, "Development of 'SPL Robots' for Construction of Tunnel Linings," *Proceedings of the Sixth International Symposium on Automation and Robotics in Construction* (June 1989), pp 190-196.

Kosowatz, John J. and Mary Powers, "Microtunneling Forges Ahead," *Engineering News-Record* (17 August 1992), pp 32-36.

Leock, Alfred, "Beyond Push-button GPS," *Civil Engineering* (June 1992), pp 75-76.

- Liu, Cheng and Jack B. Evett, *Soils and Foundations* (Prentice-Hall, Inc., 1981), Chapter 1.
- Lux, Donald G., Willis E. Ray, E. Keith Blankenbaker, and William Umstadd, *World of Construction* (McKnight Publishing Co., 1982), Chapter 30.
- Malhotra, V.M., "In Situ/Nondestructive Testing of Concrete-A Global Review," *Publication SP-82* (American Concrete Institute, 1984)
- Malinovsky, E.U., A.A. Borschevsky, E.A. Eler, and V.M. Pogodin, "A Robotic Complex for Brick-Laying Applications," *Proceedings of the Seventh International Symposium on Automation and Robotics in Construction* (June 1990), pp 32-38.
- McDonald, Willie E., "Systems for Detecting Steel Embedded in Concrete," REMR Technical Note CS- ES-1.9 (1991).
- "Mechatronically Assisted Mason's Aid [MAMA]," *Advanced Technologies Research Technical Report* (October 1990).
- Meieran, Harvey B., "How Mobile Robots Have Helped at Chernobyl and Other Accidents," *Nuclear Engineering International* (April 1988), pp 21-26.
- "Memorable Miscellany," *Concrete International* (October 1979), pp 46-62.
- MIC Industries, corporate marketing literature (1992).
- Minski, Marvin, *Robotics* (Anchor Press/Doubleday, 1985).
- Mitsui Construction, *SL System*, (1988).
- "NAVSTAR Global Positioning System Surveying," *USACE Engineering Manual* EM 1110-1-1003 (14 June 1991).
- Nomura, Hajime, Yasuo Kajjoka, Akira Okada, and Kazumi Okazumi, "Development of a Concrete Screeding Robot," *Proceedings of the Sixth International Symposium on Automation and Robotics in Construction* (June 1989), pp 459-466.
- Normile, Dennis, "Island Airport," *Popular Science* (March 1991), pp 62-63+.
- Ohbayashi Corp., *Automatic Construction System*, corporate marketing literature (1988).
- Okamoto, Paul A., "Field Evaluation of Dowel Placement Along a Section of Interstate 45 in Texas," *Transportation Research Record, 1186* (1988), pp 16-34.
- Paulsen, B.C., Jr., "Automation and Robotics for Construction," *Journal of Construction Engineering and Management* (March 1985), pp 190-207.
- Perreira, Dr. N. Duke and Dr. B. Vincent Viscomi, "An Automated Construction Erection System," (Lehigh University 1991).
- Pilditch, A.P., "An Appraisal of Automation in Construction Surveying," *West Indian Journal of Engineering* (January 1986), pp 12-20.
- "Product Progress," *Concrete Construction* (March 1992), pp 268.
- Saito, M., N. Tanaka, K. Arai, K. Banno, T. Ochi, and S. Kikuchi, "The Development of the 'Mark II' Mobile Robot for Concrete Slab Finishing," Technical Report, Mechanical Engineering Development Department, Kajima Company, Tokyo, Japan. CAD and Robotics in Architecture and Construction, *Proceedings of the Joint Conference at Marseilles* (25-27 June 1986).

- Sato, Kiyoshi, "Shield Method Automation System," *Proceedings of the Sixth International Symposium on Automation and Robotics in Construction* (June 1989) pp 49-55.
- Scott, H.F., and D.J. Gunton, "Ground-Probing Radar—A Technique For Mapping Buried Pipelines and Cables," *Pipes and Pipelines International* (September - October 1987), pp 7 -10.
- Shimizu Corp., *Construction Robot*, corporate marketing literature (1988).
- Shimizu Corp., corporate marketing literature (1988).
- Shimizu Corp., "Steel Beam/Column Assembly Robot," *Construction Robot*.
- Skibniewski, Mirosław J. and Jeffrey S. Russell, "Robotic Applications to Construction," *Cost Engineering* (June 1989), pp 11-18.
- Skibniewski, Mirosław J. and Martin Ostojca-Starzewski, "A Master-Slave Manipulator for Excavation and Construction Tasks," *Robotics and Autonomous Systems* (April 1989), pp 333-337.
- Slocum, Alexander and Bruce Schena, "Blockbot: A Robot to Automate Construction of Cement Block Walls," *Robotics* (April 1988), pp 111-119.
- Slocum, Alexander Henry, "The Design and Fabrication of an Automated Shear Stud Welding System," *Proceedings of the Sixth International Symposium on Automation and Robotics in Construction* (June 1989), pp 135-142.
- Slocum, Alexander H. and Andrew G. Ziegler, "An Automated Shear Stud Welding System," *Robotics and Autonomous Systems* (June 1990), pp 367-382.
- Steel Deck Institute Design Manual (Steel Deck Institute 1989).
- Suprenant, Bruce A, "Concrete Vibration," *Concrete Construction* (June 1988), pp 563-568.
- "System Cuts Labor Needs," *Engineering News-Record* (11 November 1991), pp 21.
- Takada, Hiroo, "The Integrated Construction System," *Proceedings of the Seventh International Symposium on Automation and Robotics in Construction* (June 1990), pp 134-144.
- Takemoto, Yasushi, Yasuyoshi Nagai, Shozaburo Shimaguchi, Yasuo Inoue, and Takaaki Matsunami, "An Automated System for Concreting in Building Sites—Development of Automated Consolidation Subsystem," *Proceedings of the Sixth International Symposium on Automation and Robotics in Construction* (June 1989), pp 451-458.
- Takenaka Corp., *Automated Concrete Work-Horizontal Concrete Distributor*, corporate marketing literature (1988).
- Takenaka Corp., *Automated Concrete Work-Screed Robo*, corporate marketing literature (1988).
- Takenaka Corp., *Automated Concrete Work-Surf Robo*, corporate marketing literature (1988).
- Tatum, C.B. and A.T. Funke, "Partially Automated Grading," *Journal of Construction Engineering and Management* (March 1988), pp 19-35.
- Technical Specifications for Miller Formless Systems, Automated Slipforming Systems, Bulk Cement Unloading Systems, (Miller Formless Company, Inc., 1992).
- "The SMART System," *Shimizu News Release* (16 October 1991).

- Torisaki, Shunsuke and Shinichi Nakatsuji, "The Worldwide Status of Construction Electronics," *The Specifications and Applications of Industrial Robots in Japan* (1988), pp 132-135.
- "Tunneling Scheme Takes a Bow," *Engineering News-Record* (6 December 1984), pp 28-29.
- "Undersea Plow Sets Pipeline in Trench," *Hydraulics and Pneumatics* (August 1983), pp 10-11.
- "USACE, The Unified Soil Classification System," *Waterways Experiment Station Technical Manual 3-357* (Vicksburg, MS, 1953).
- Ventre, Francis T., "Innovation in the Residential Construction," *Technology Review* (November 1979), pp 51-59.
- Wakisaka, Tatsuya, Yasushi Takemoto, Takaaki Matsunami, Yasukuni Kamimura, Takayasu Fujii, and Sadamachi Tamai, "Automization of Reinforcement Work in Highrise Reinforced Concrete Buildings," *Proceedings of the Seventh International Symposium on Automation and Robotics in Construction* (June 1990), pp 79-86.
- Walker, B.J. and D. Beadle, *Mechanized Construction of Concrete Roads* (Cement and Concrete Association, June 1975).
- Whittaker, William L., "Evolution of an Excavator," CAD and Robotics in Architecture and Construction, *Proceeding of the Joint International Conference at Marseilles* (25-27 June 1986).
- Wohlford, William, F.D. Griswold, and B.D. Bode, "New Capability for Remote Controlled Excavation," *Proceedings of the 38th Conference on Remote Systems Technology* (1990), pp 228-232.
- Wood, Stuart Jr., *Heavy Construction* (Prentice-Hall, Inc., 1977), Chapter 1.
- Yamamoto, Minoru, "The Latest Shield Tunneling Technology in Japan," *Japanese Railway Engineering* (December 1989), pp 9-12.
- Yamashita, Toshio, Yoshimasa Tsuchiya, Masahiro Tamaki, and Isamu Yamamoto, "Prefabrication of Reinforcing Bars Using CAD/CAM," *Proceedings of the Sixth International Symposium on Automation and Robotics in Construction* (June 1989), pp 261-268.

APPENDIX A: Sitework Construction Automation Technologies

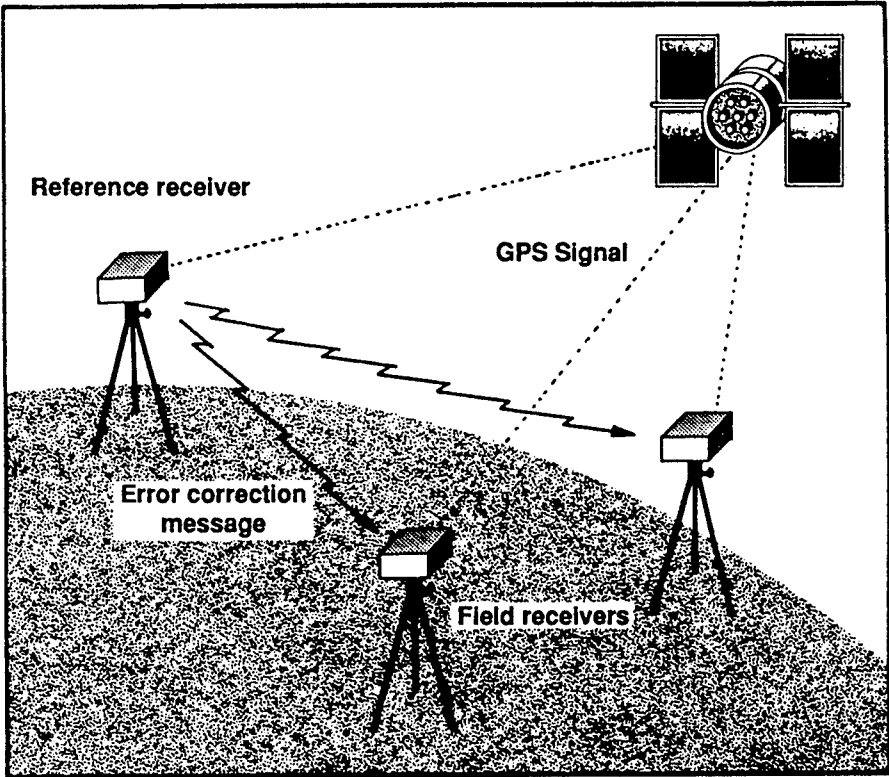

Source: Hurn, Jeff, *GPS: A Guide to the Next Utility*, ©1989, Trimble Navigation Ltd. Reprinted by permission.

Figure A1. Global Positioning System.

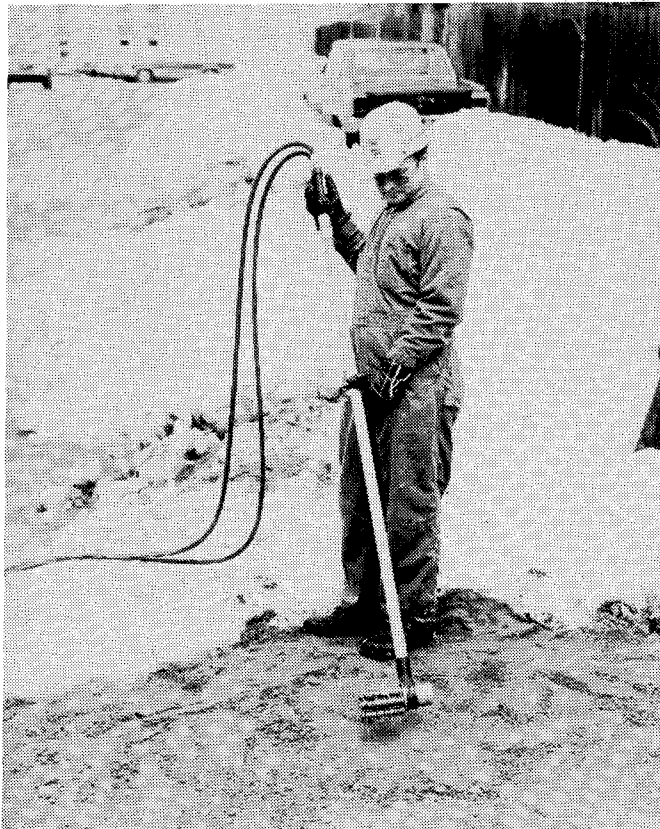
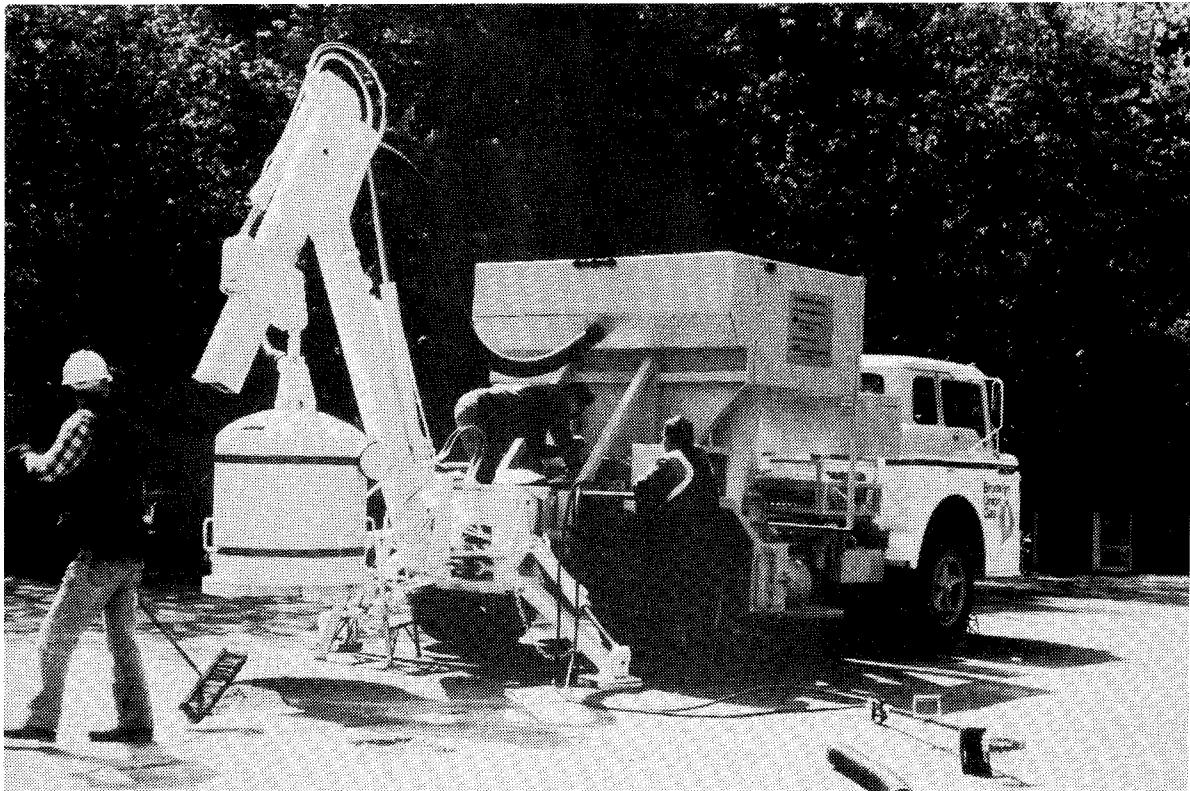

Source: Foster-Miller, Inc., Technology Developers. Reprinted by permission.

Figure A2. Soft Excavator.

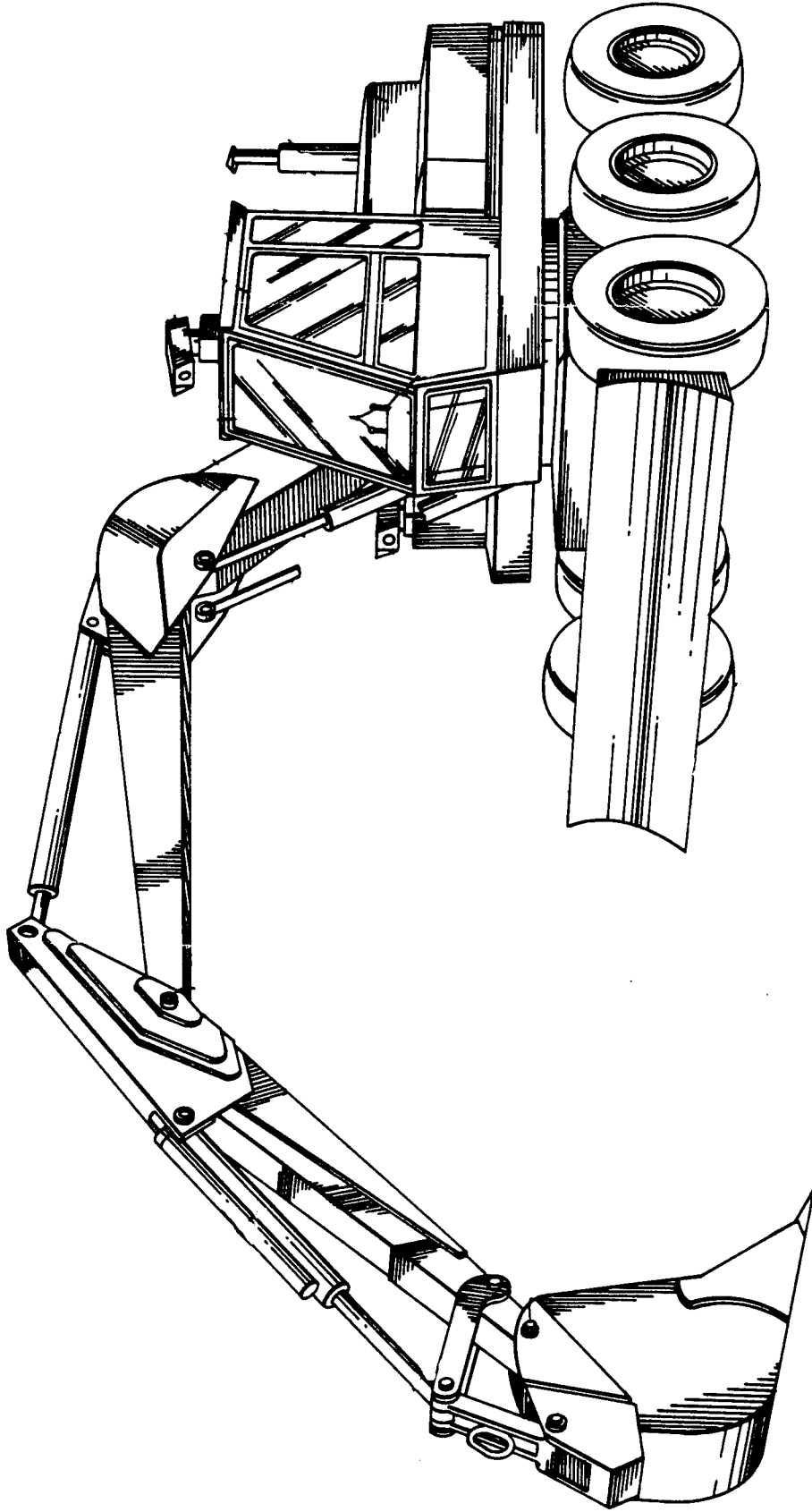

Source: Wohlford, William P. F.D. Griswold, and B.D. Bode, *Proceedings of the 39th Conference on Remote Systems Technology (New Capability for Remote Controlled Excavator)*, ©1990, Vol 2, Deere & Company. Reprinted by permission.

Figure A3. Torce.



Figure A4. RRR Excavator.

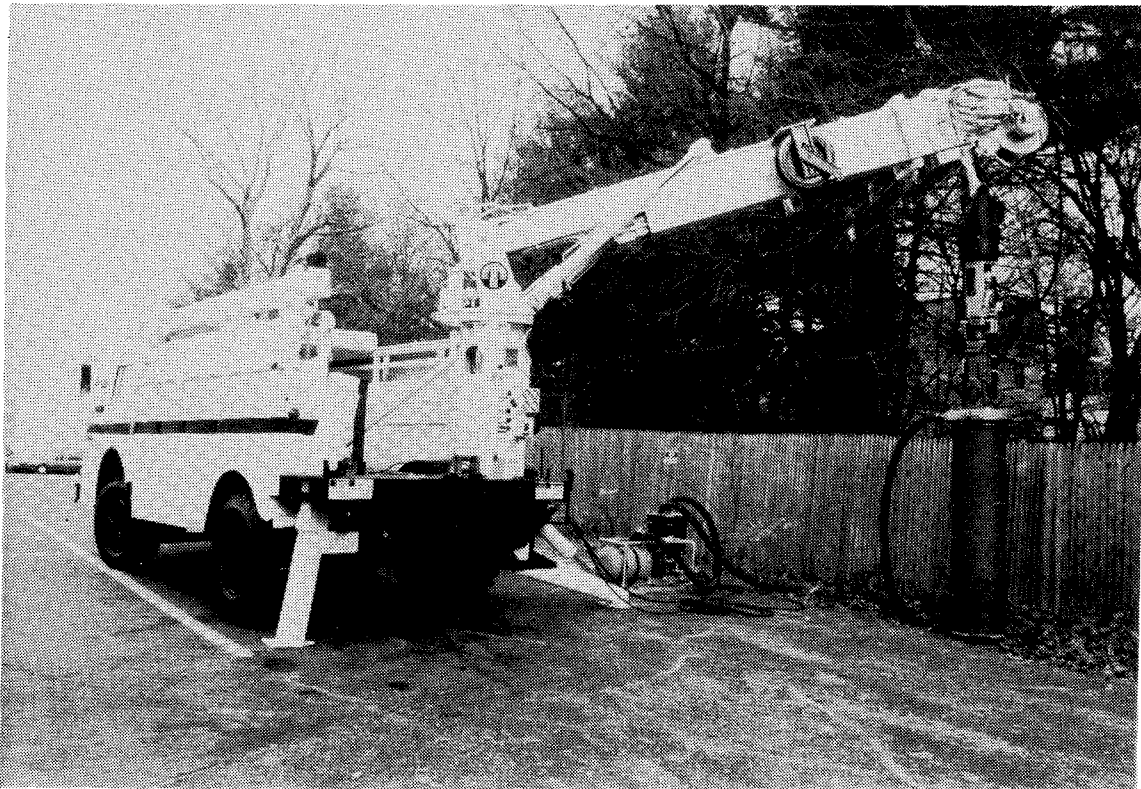

Source: Foster-Miller, Inc., Technology Developers. Reprinted by permission.

Figure A5. Rock Drill.

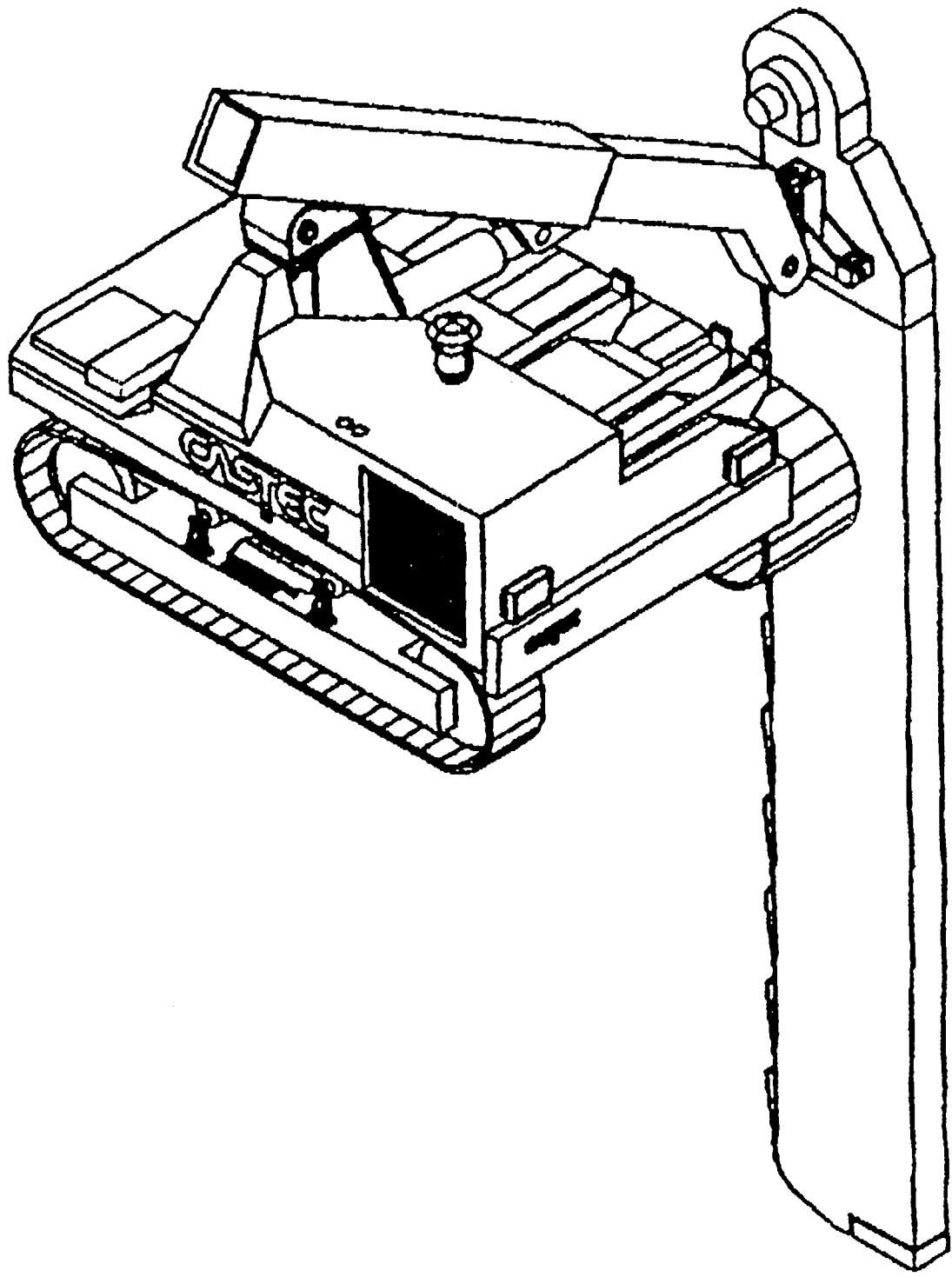
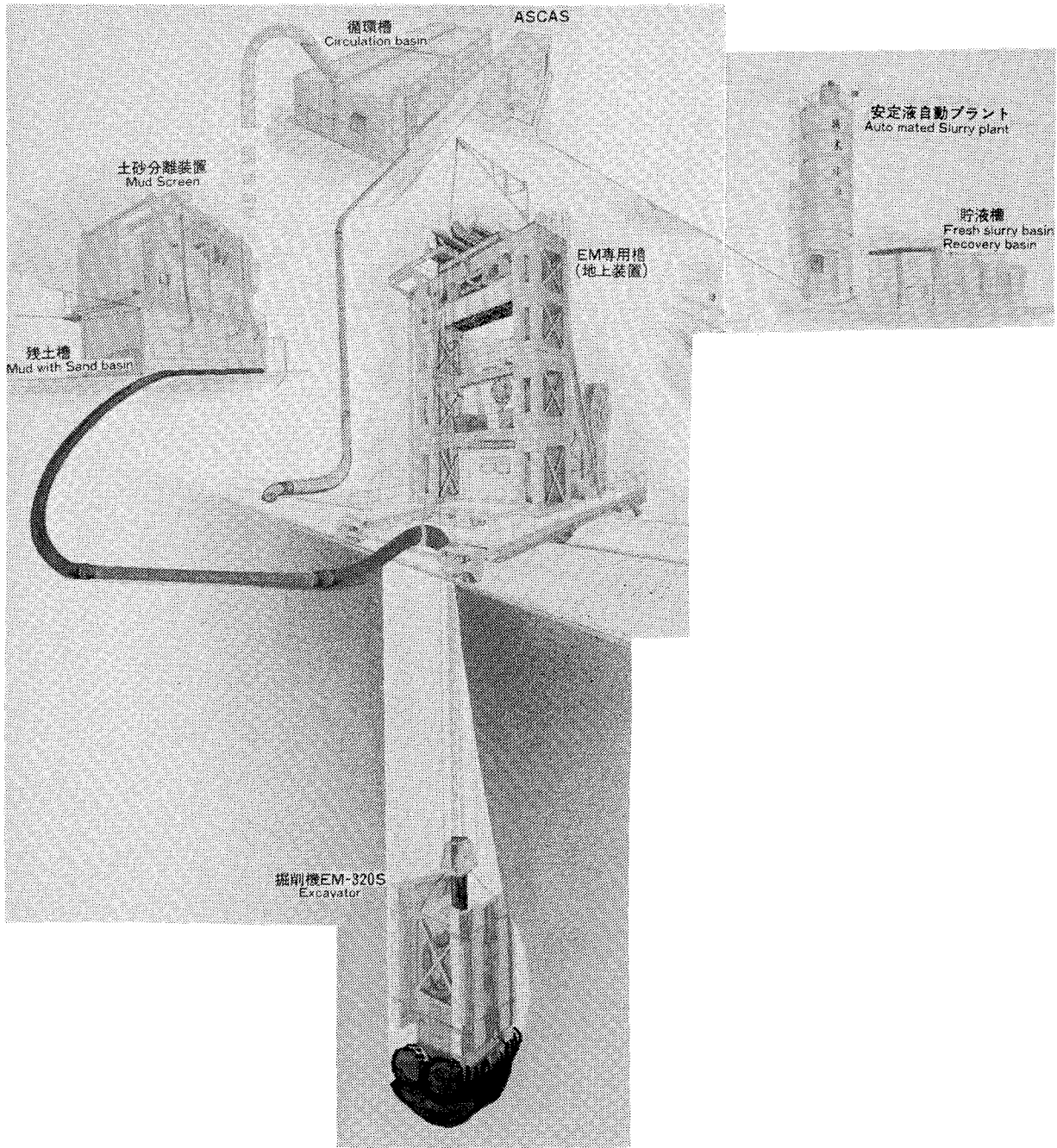
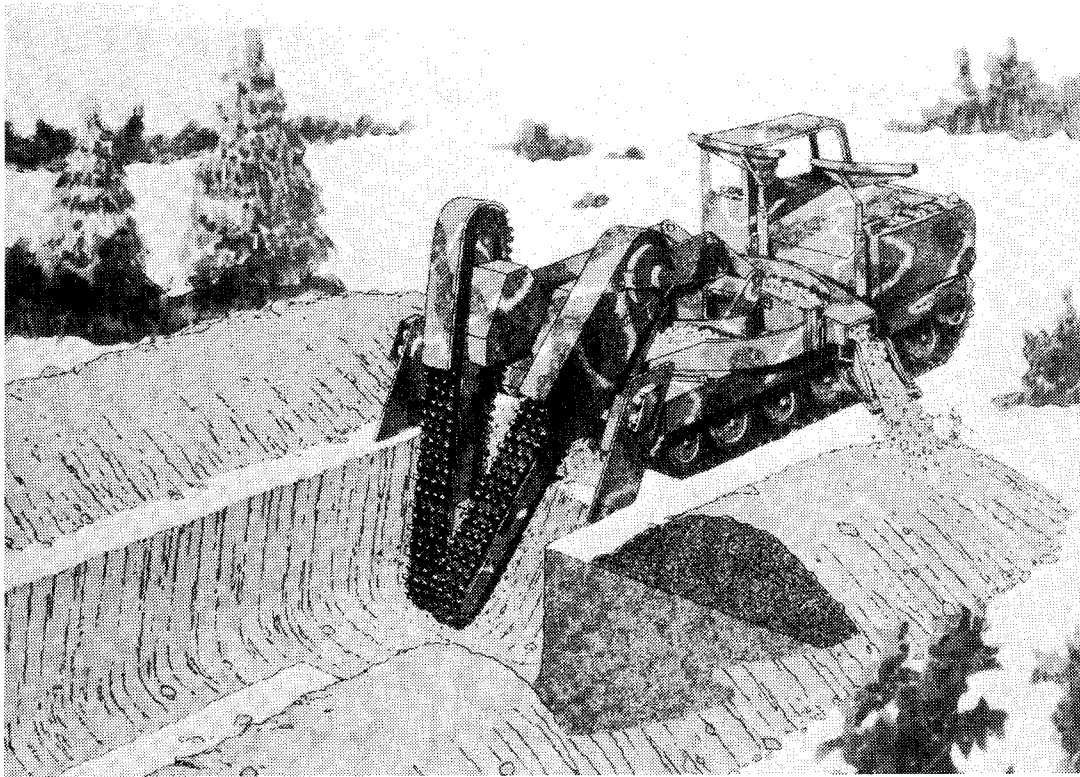

Figure A6. CASTEC System.



Source: Shimizu Corporation. Reprinted by permission.

Figure A7. SSS-G.



Source: Foster-Miller, Inc., Technology Developers. Reprinted by permission.

Figure A8. High-Speed Excavator.

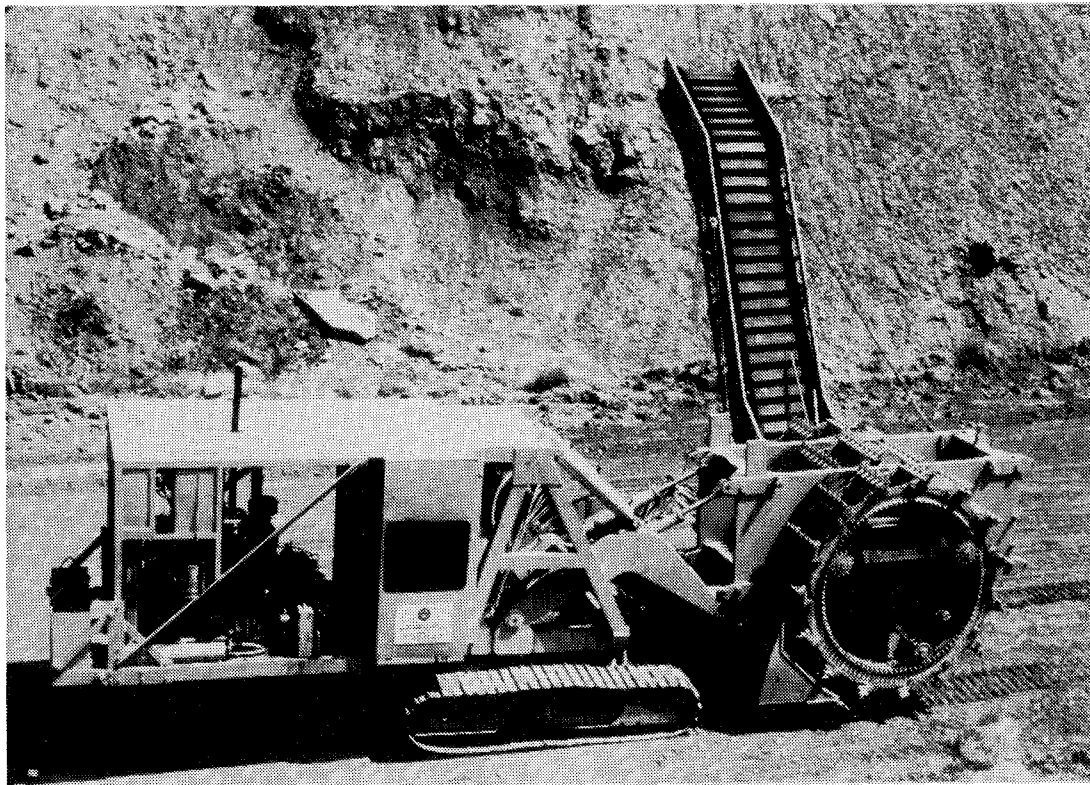

Source: Foster-Miller, Inc., Technology Developers. Reprinted by permission.

Figure A9. Overburden Excavator.

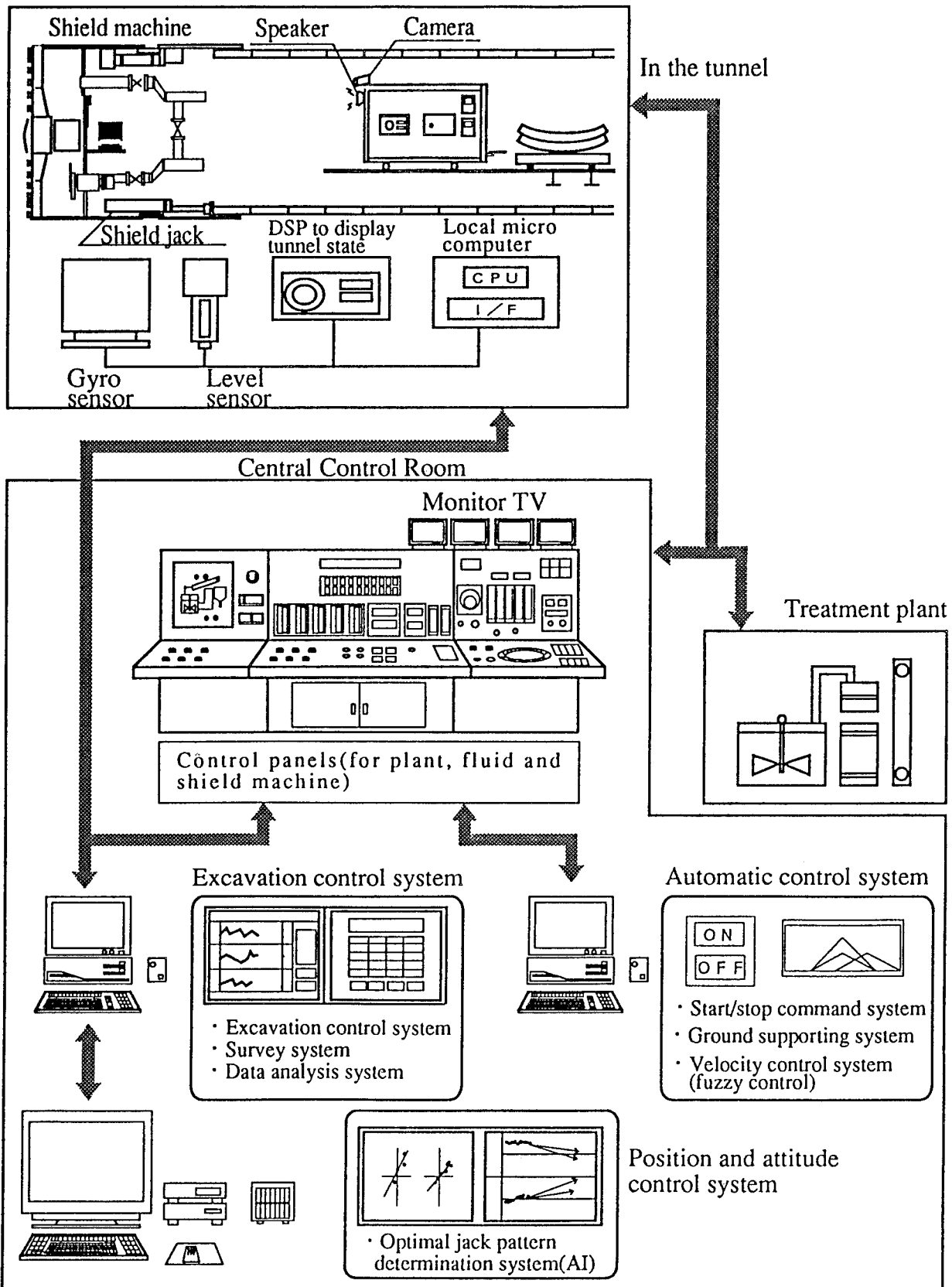

Source: Fujita Corporation. Reprinted by permission.

Figure A10. Automated Shield Tunneling.

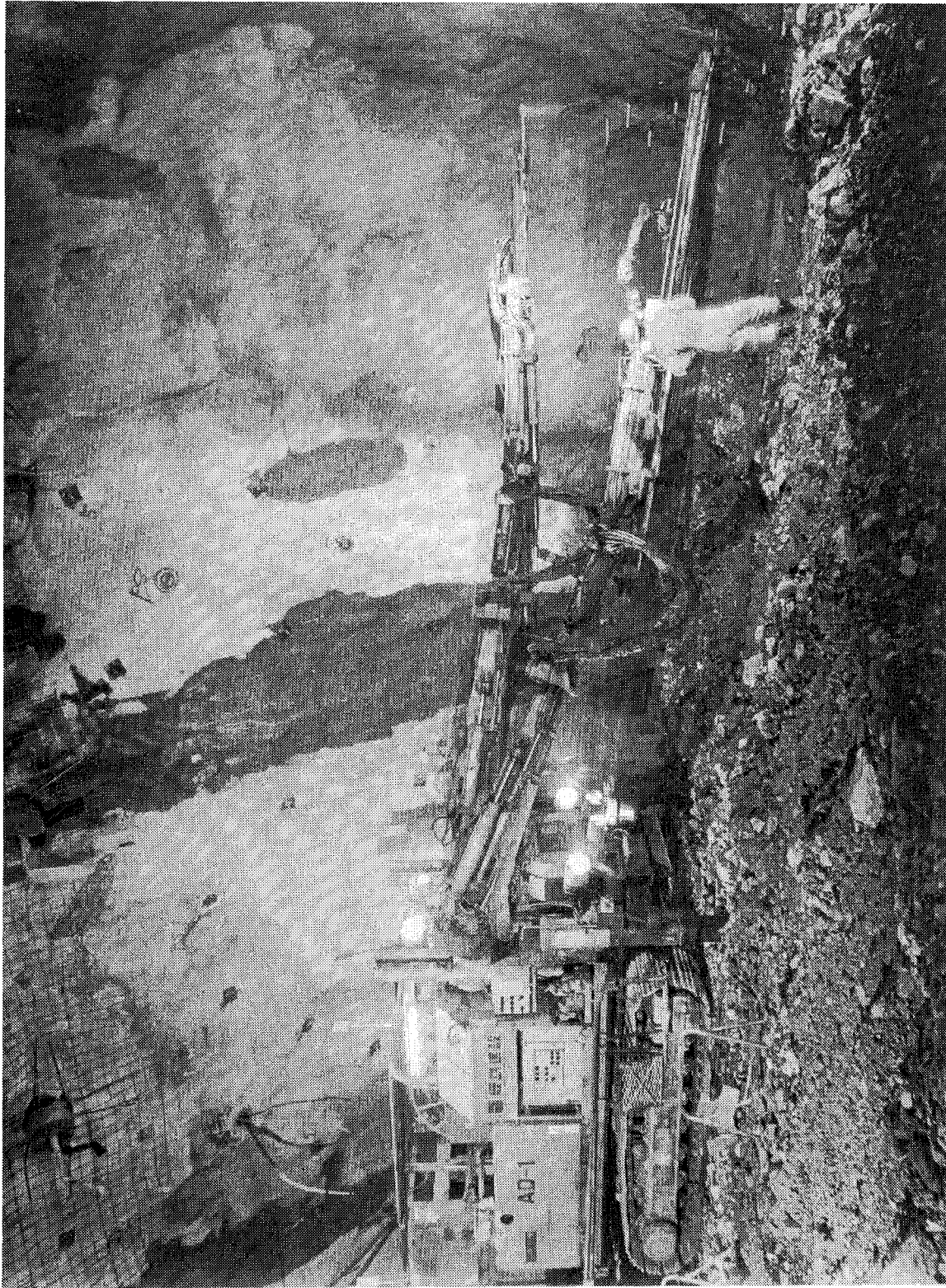

Source: Kajima Corporation. Reprinted by permission.

Figure 11. Drilling Jumbo.

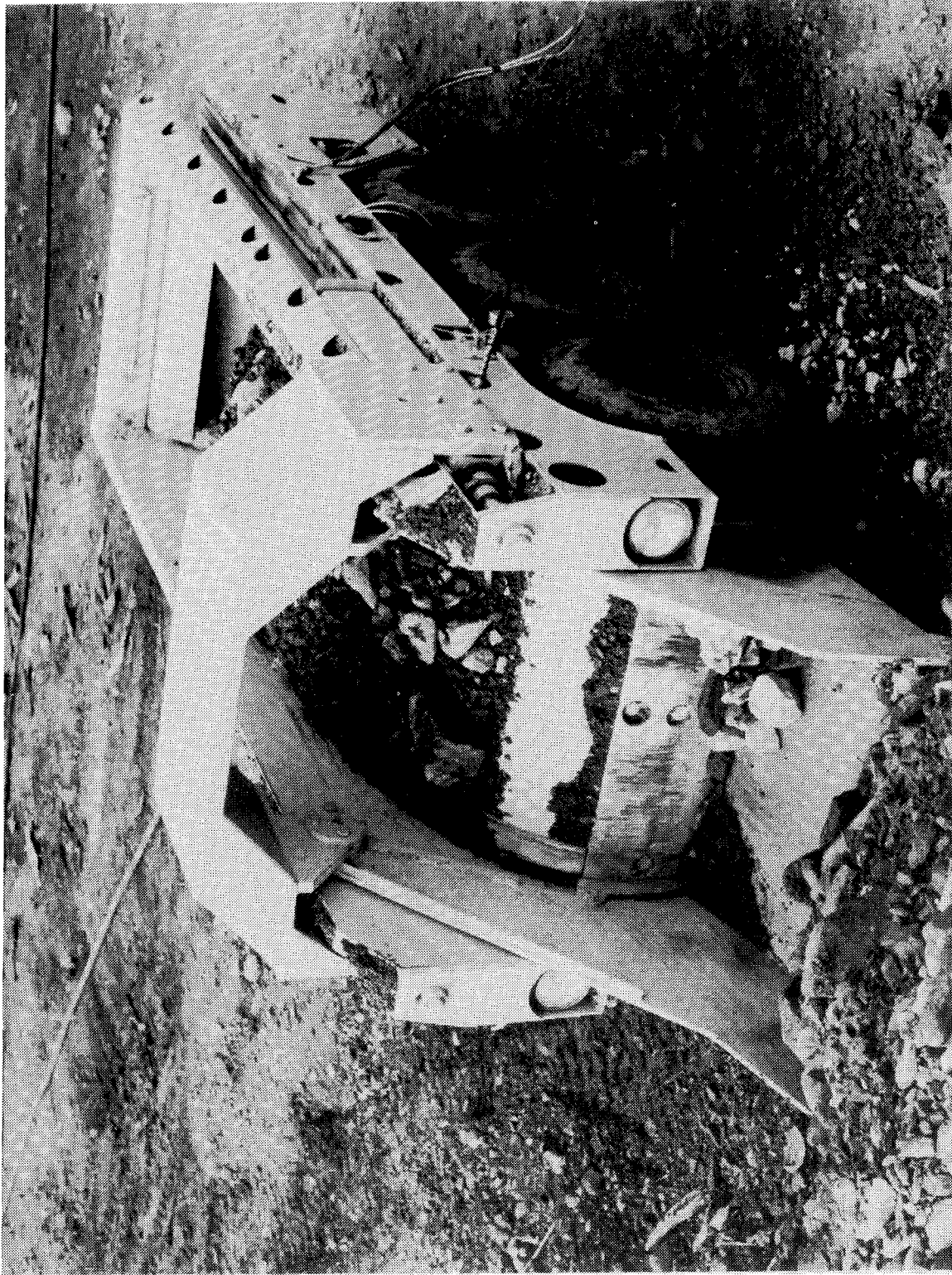

Source: Foster-Miller, Inc., Technology Developers. Reprinted by permission.

Figure A12. Mini Mucker.

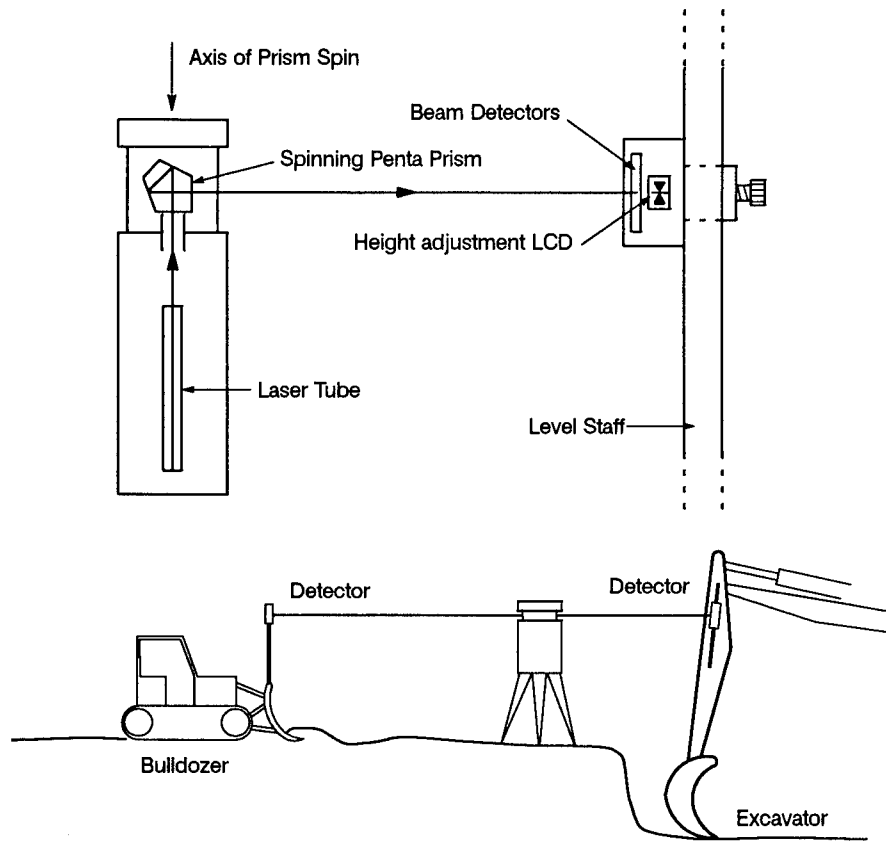

Source: Pilditch, A.P., *An Appraisal of Automation in Construction Surveying*, ©Jan 1986, Vol 2, West Indian Journal of Engineering. Reprinted by permission.

Figure A13. Laser Grading.

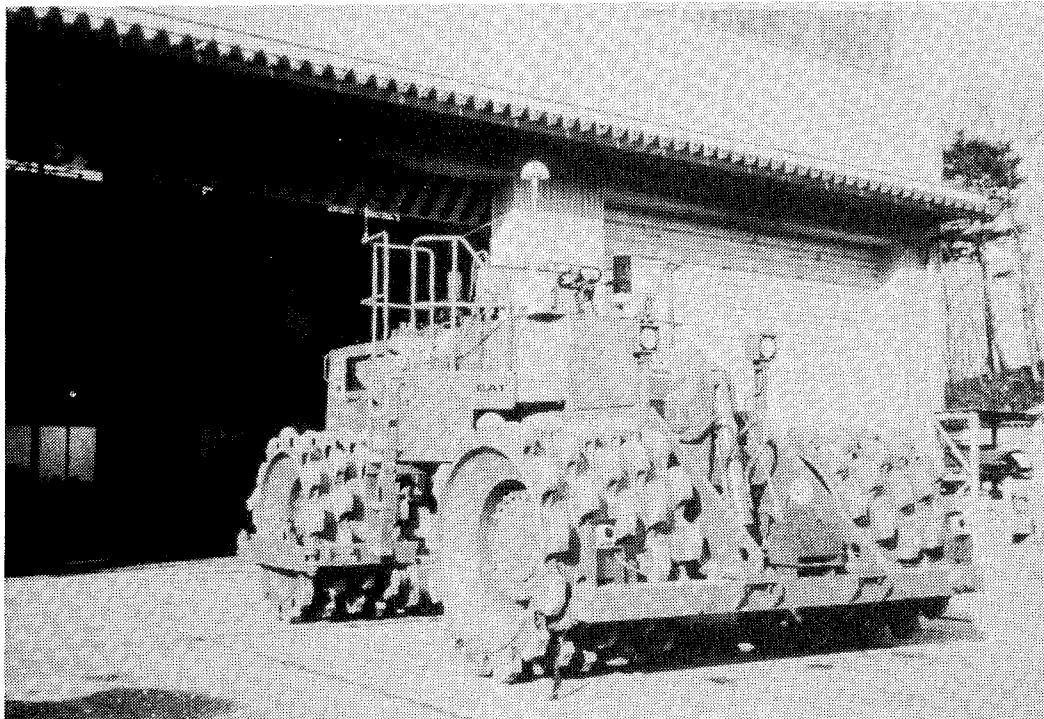

Source: Fujita Corporation. Reprinted by permission.

Figure A14. Automated Compaction.

APPENDIX B: Concrete Construction Automation Technologies

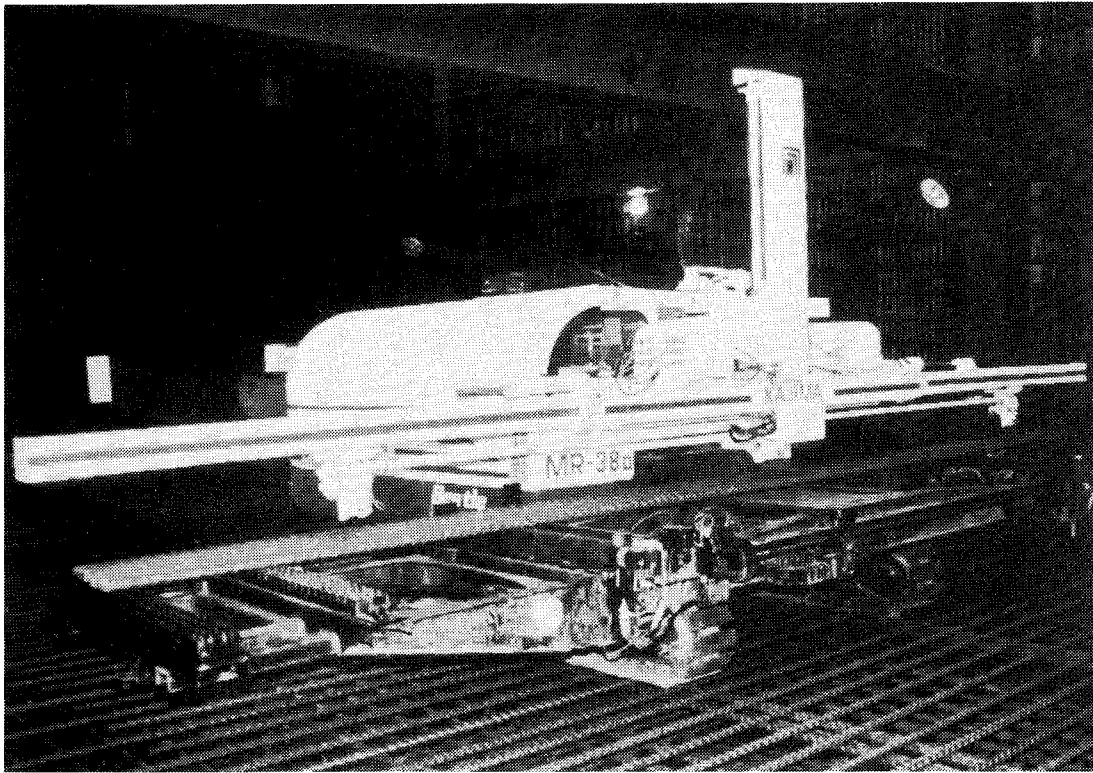

Source: Kajima Corporation. Reprinted by permission.

Figure B1. Rebar-Arranging Robot.

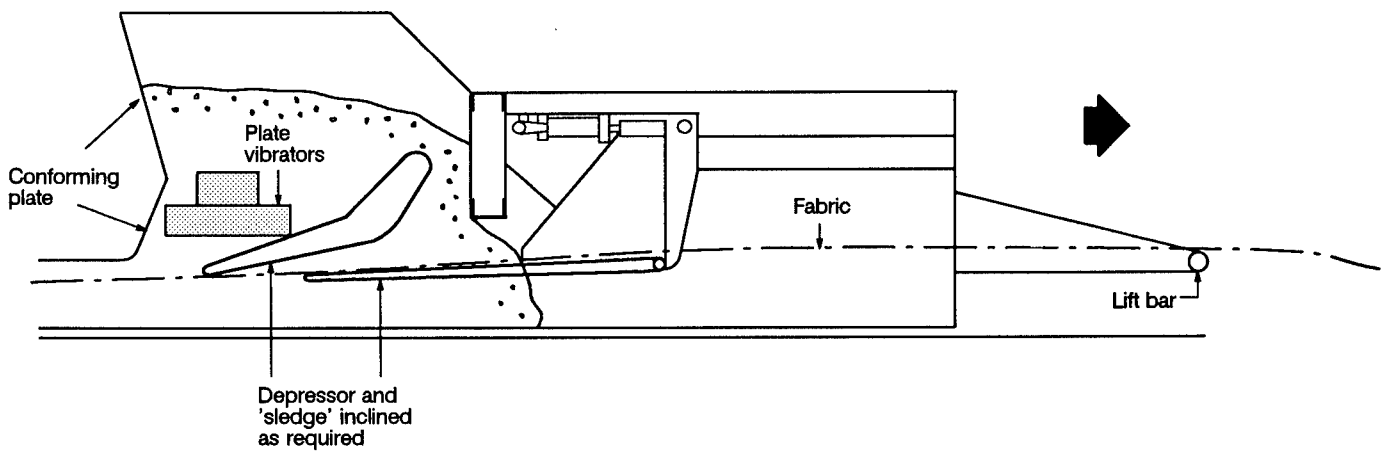
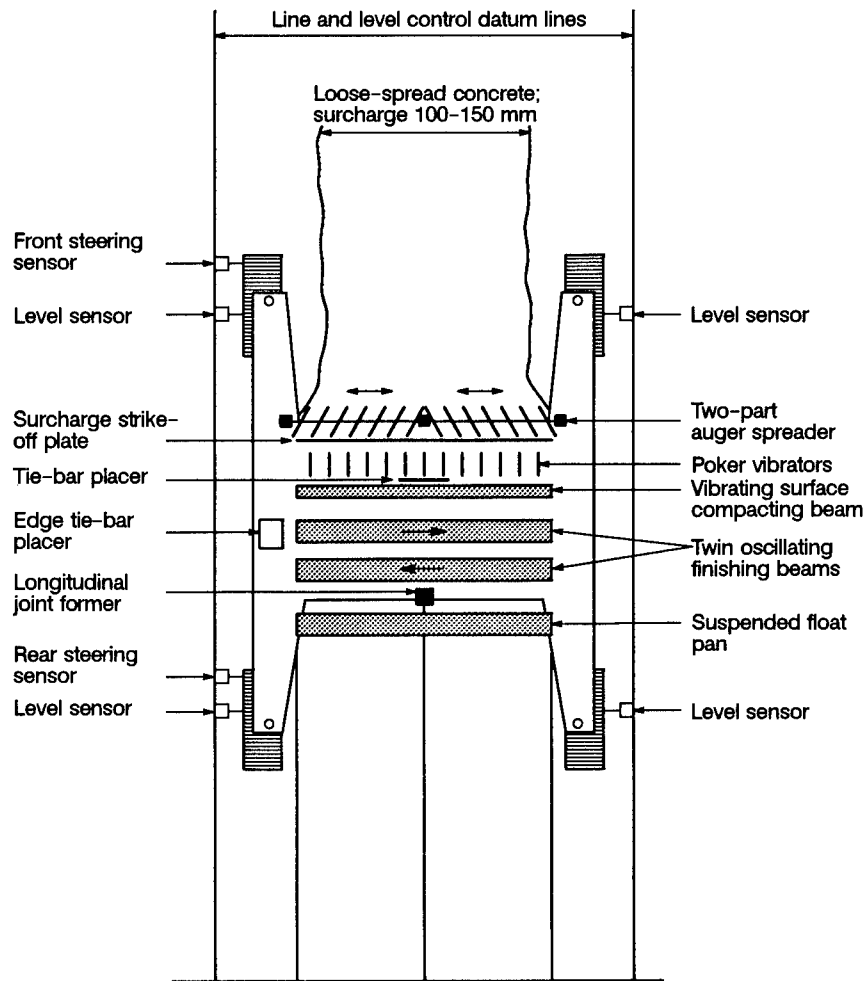

Source: Walker, B.J., and D. Beadle, *Mechanized construction on concrete roads*, ©1975, British Cement Association. Reprinted by permission.

Figure B2. Slipforming.

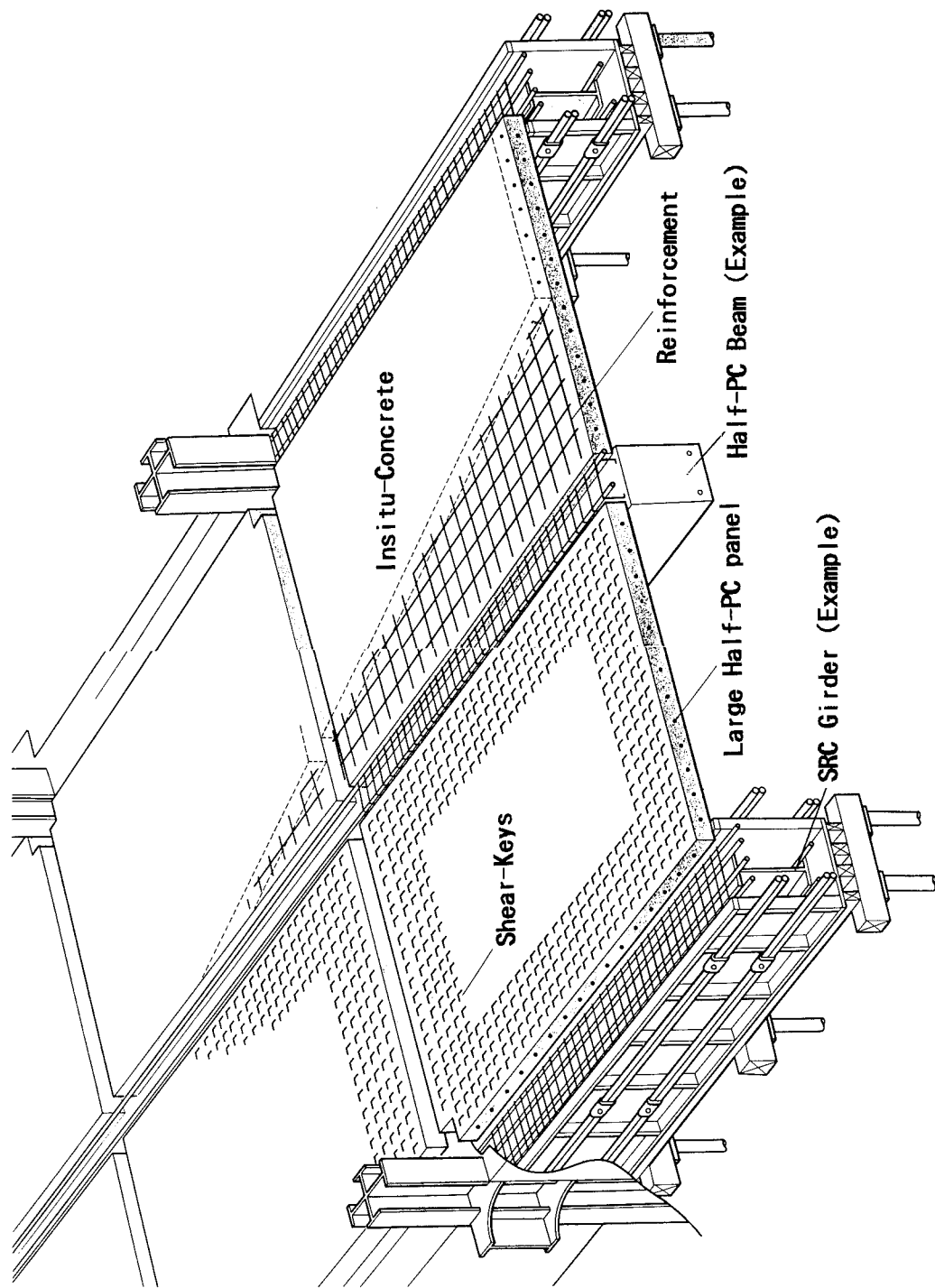

Source: Takada, Hiroo, "The Integrated Construction System," *Proceedings of the Seventh International Symposium on Automation and Robotics in Construction*, ©June 1990, Shimizu Corporation. Reprinted by permission.

Figure B3. Integrated Construction System.

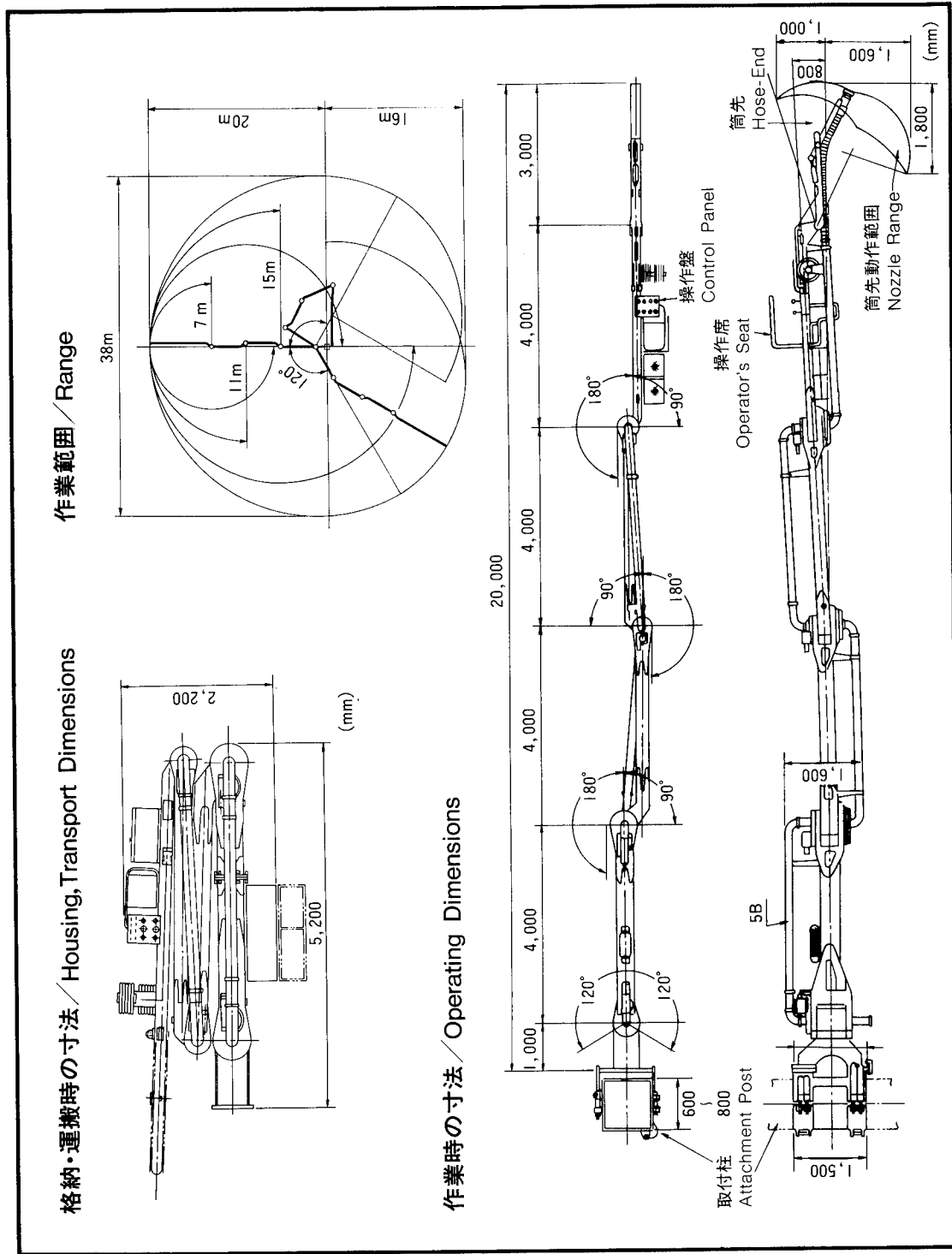

Source: Takenaka Corporation. Reprinted by permission.

Figure B4. Horizontal Concrete Distributor.



Source: Ohbayashi Corporation. Reprinted by permission.

Figure B5. Concrete Spraying Robot.

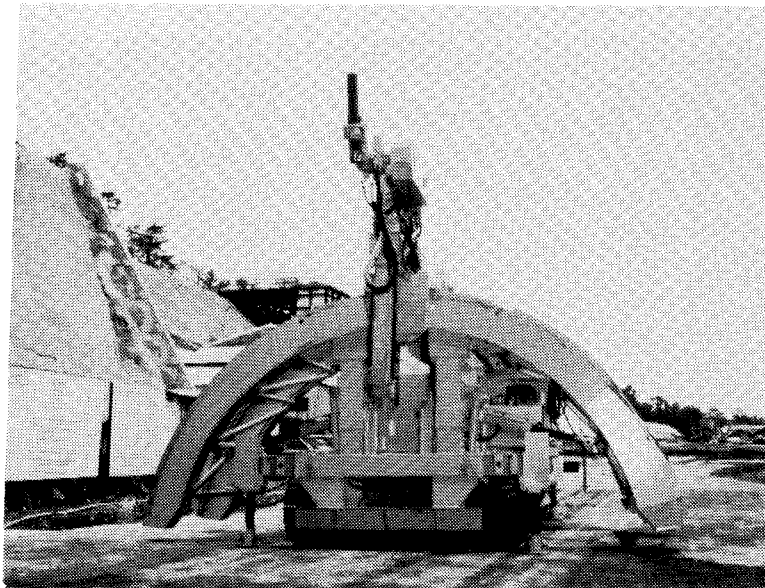

Source: Mitsui Corporation. Reprinted by permission.

Figure B6. Shotcrete Robot.

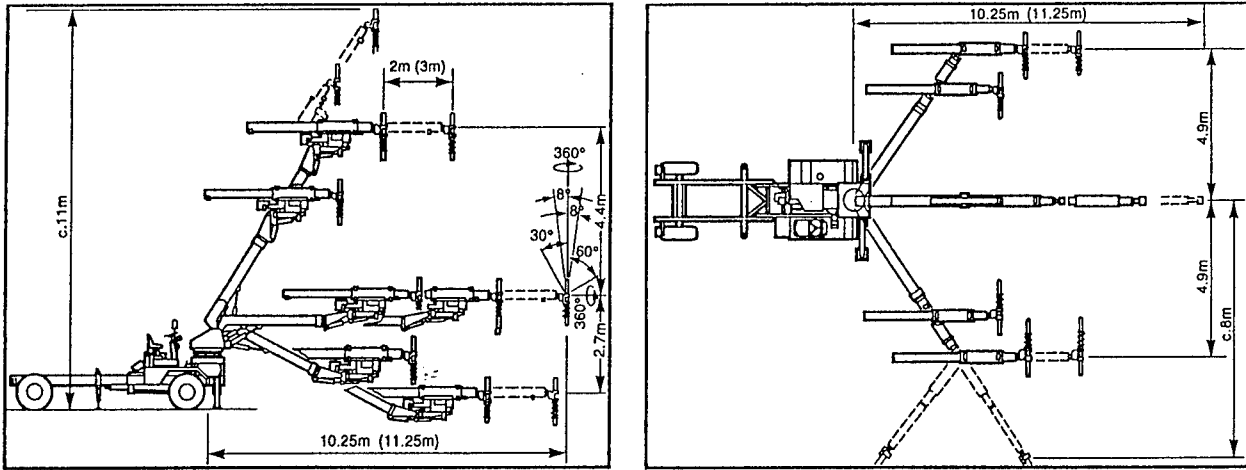

Source: "Channel Tunnel gets well sprayed," *Tunnels and Tunneling*, ©July 1989, Morgan-Grampion (Construction Press) Limited. Reprinted by permission.

Figure B7. Meyco Spraying Robot (Meynadier).

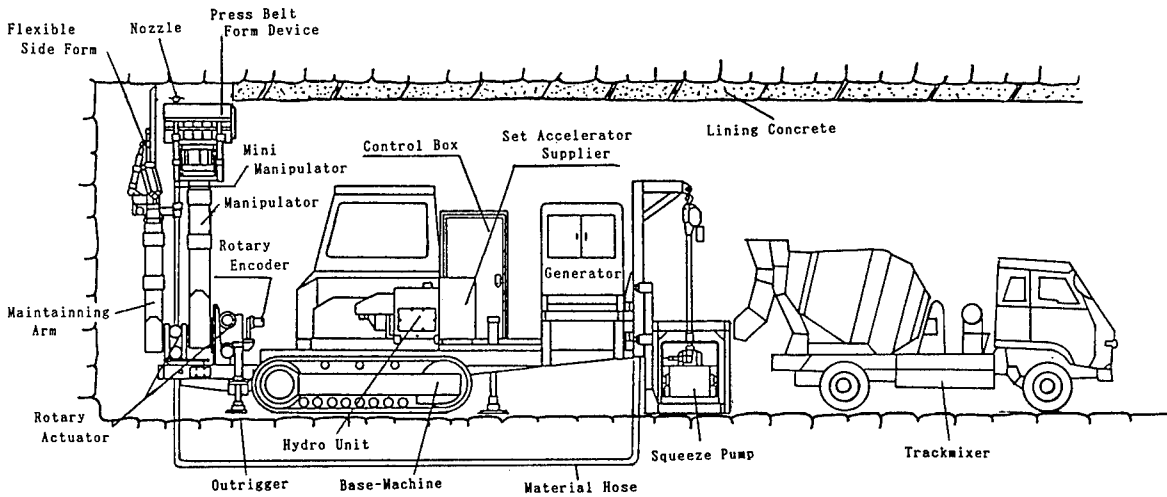

Source: Koga, Shigetoshi, and Akimasa Waku, "Development of 'SPL' for Construction of Tunnel Linings," *Proceedings of the Sixth International Symposium on Automation and Robotics in Construction*, ©June 1989, Fujita Corporation. Reprinted by permission.

Figure B8. Slide Press Lining Robot.

No.1 Unit
Vibration completed
remounting of vibrators

No.2 Unit
Vibrator action
and stand-by

No.3 Unit
Vibrator stand-by

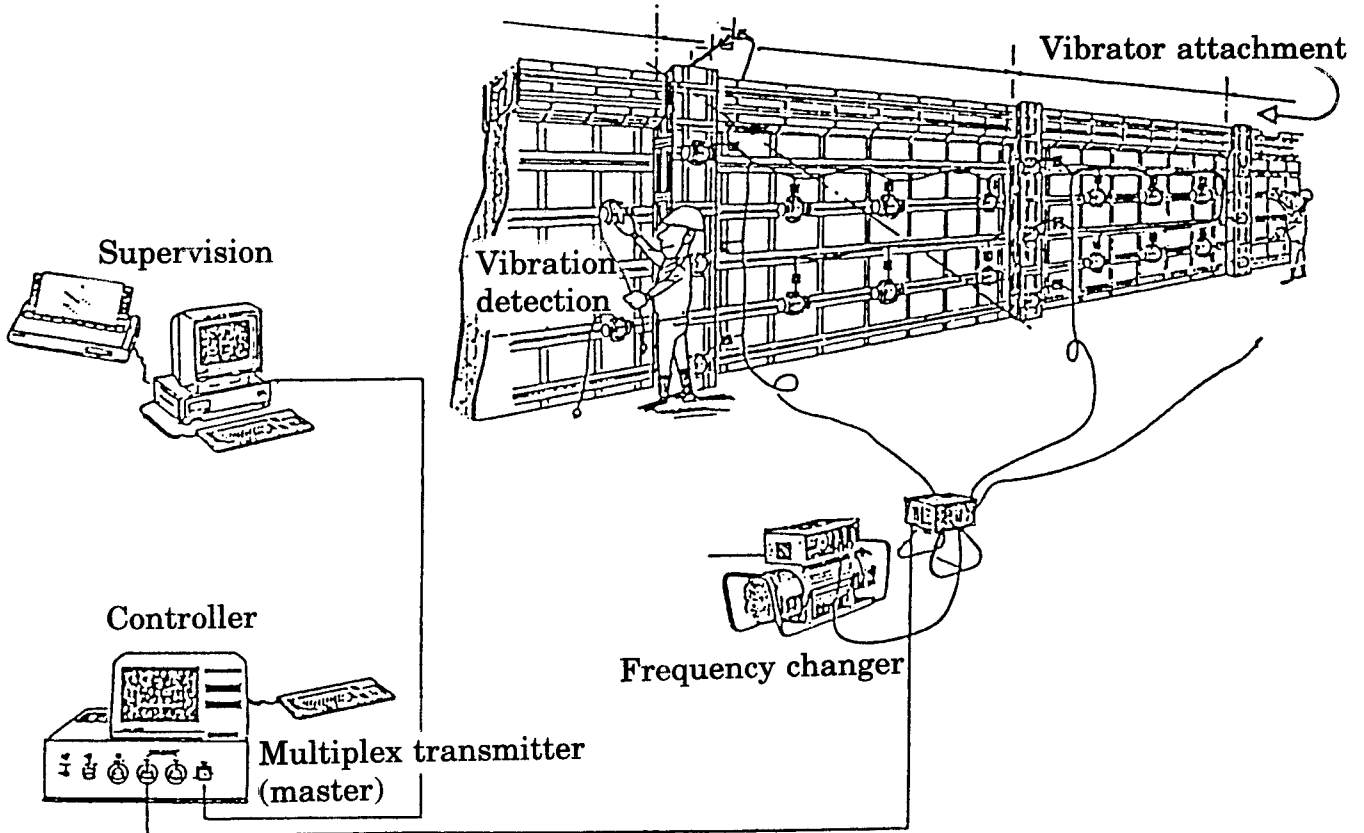

Source: Takemot, Yasusi, et al., "An Automated System for Concreting in Building Sites—Development of Automated Consolidation Subsystem," *Proceedings of the Sixth International Symposium on Automation and Robotics in Construction*, ©June 1989, Ohbayashi Corporation. Reprinted by permission.

Figure B9. Automatic Exterior Vibrator/Tamper.

Girder Mounted Type

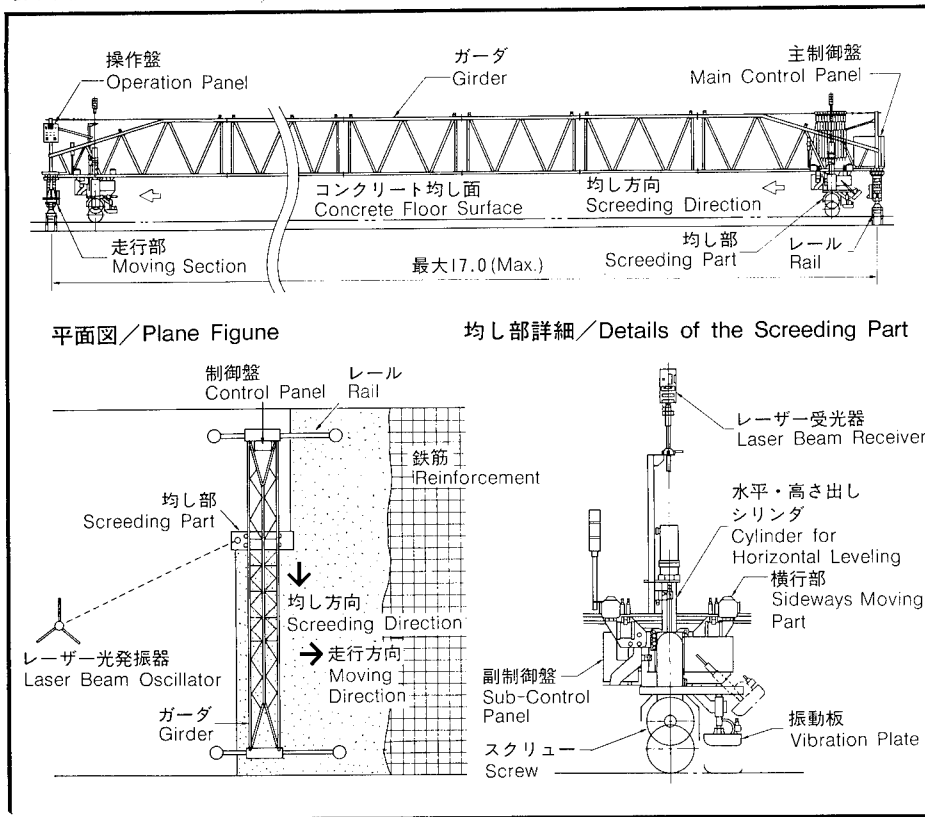

Motor Vehicle Mounted Type

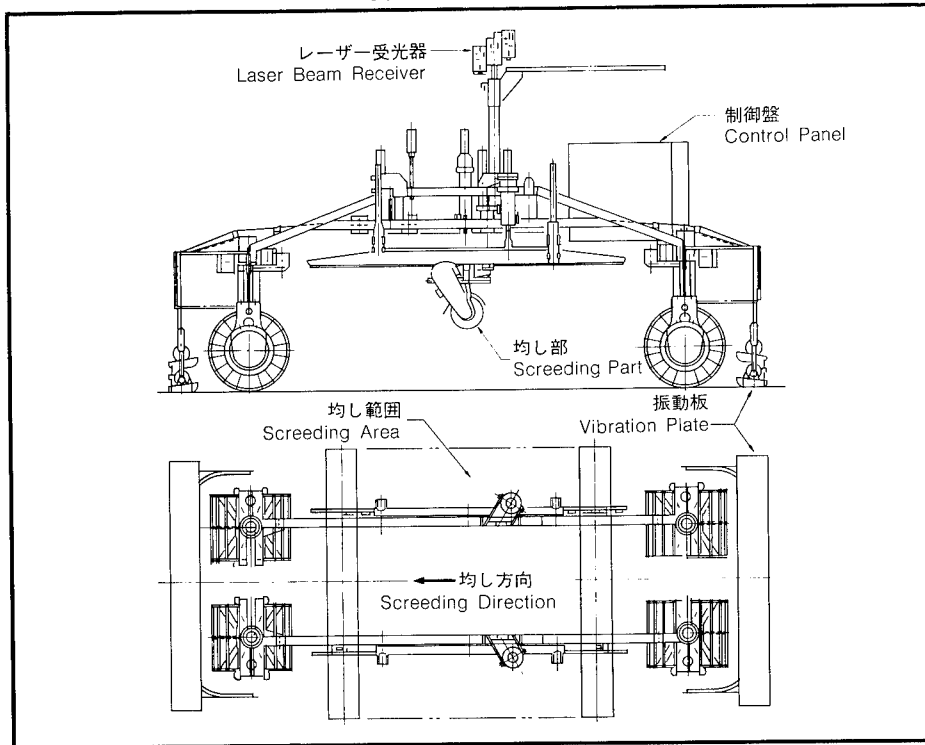

Source: Takenaka Corporation. Reprinted by permission.

Figure B10. Screed Robo.

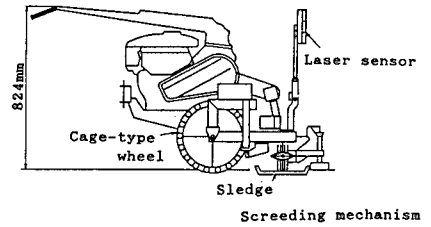
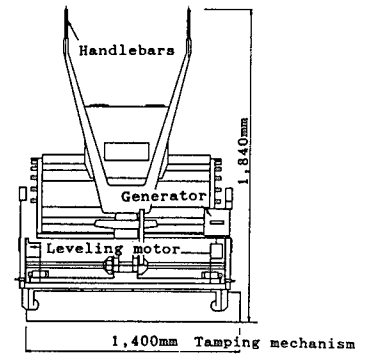
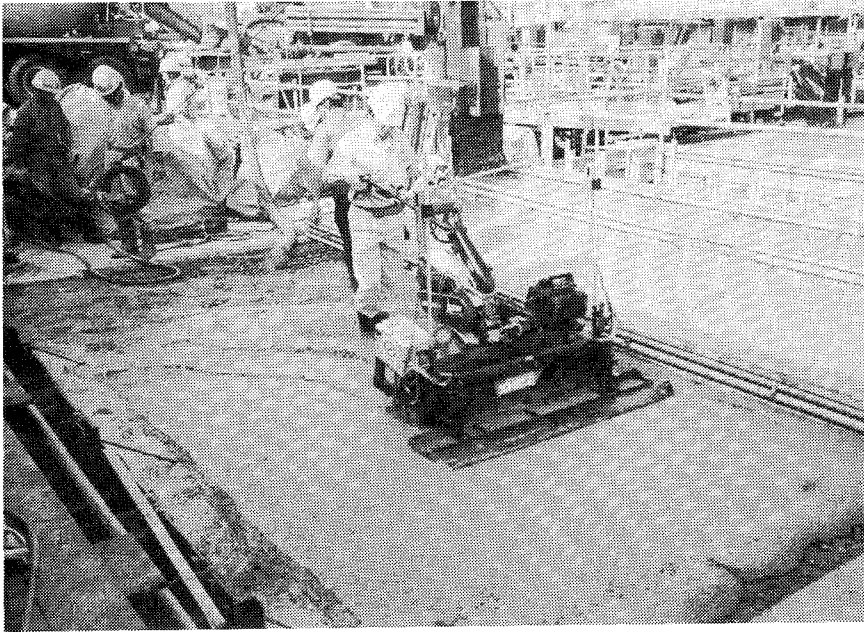

Source: Nomura, Hajime, et al., "Development of a Concrete Screeding Robot," *Proceedings of the Sixth International Symposium on Automation and Robotics in Construction*, ©June 1989, Shimizu Corporation. Reprinted by permission.

Figure B11. Concrete-Screeding Robot.

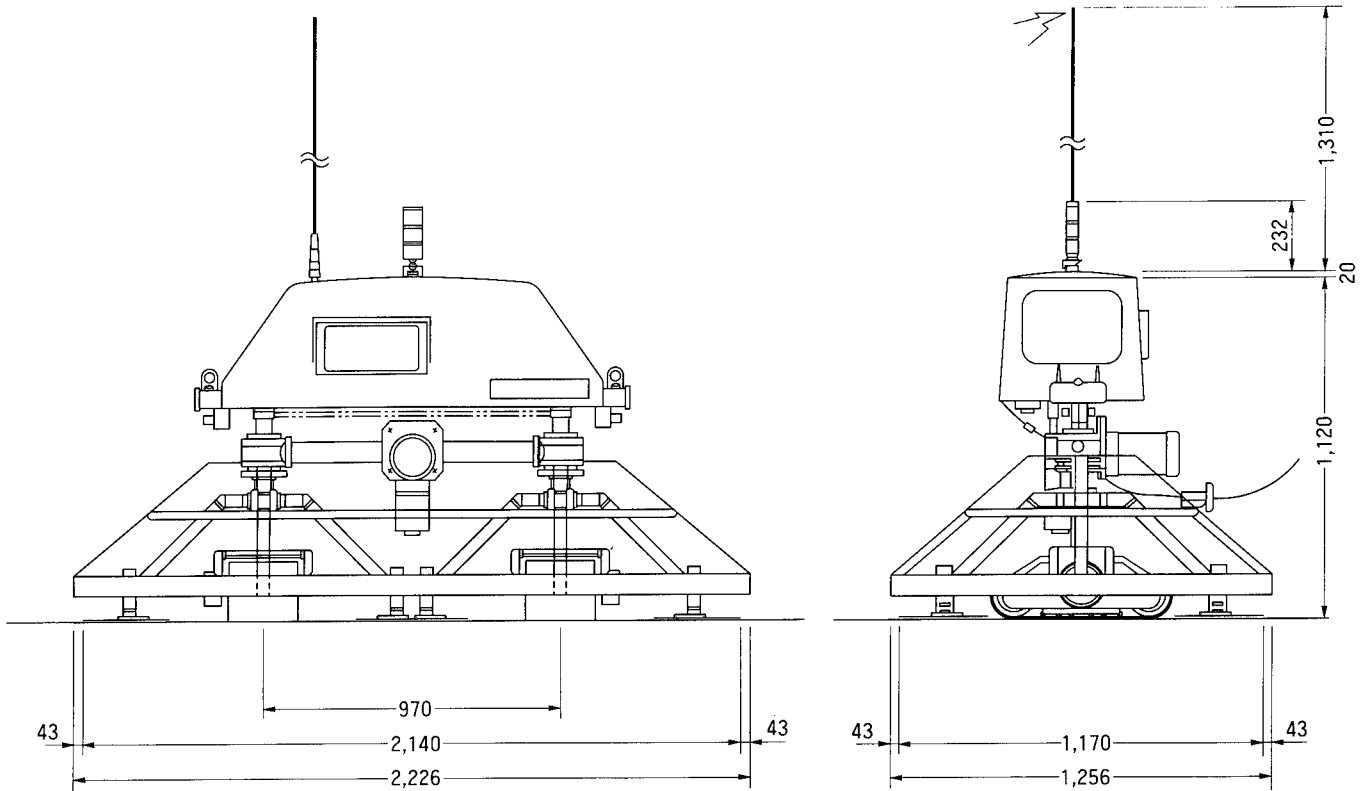

Source: Takenaka Corporation. Reprinted by permission.

Figure B12. Surf Robo.

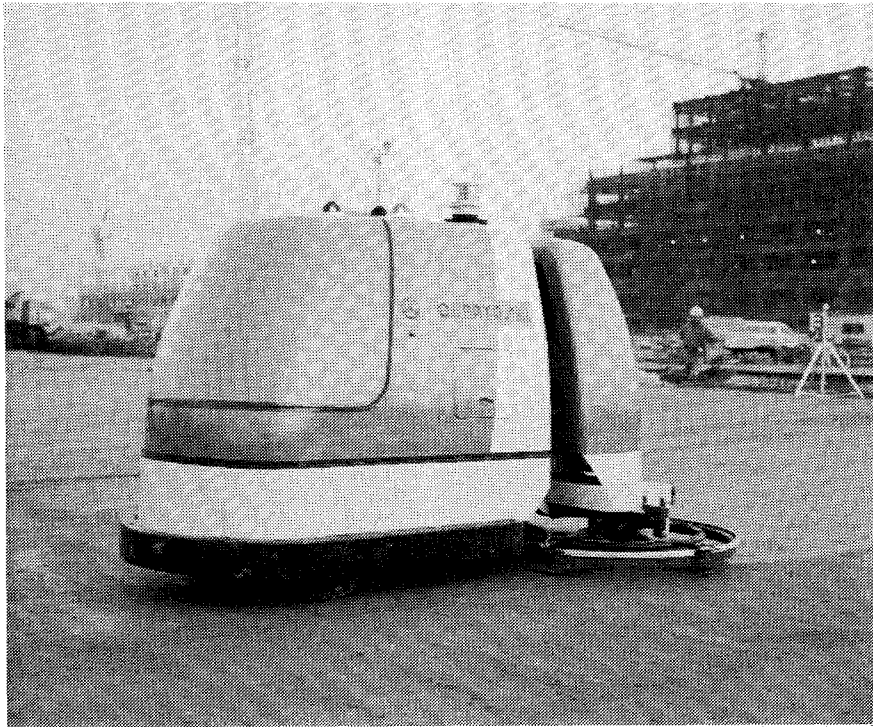

Source: Ohbayshi Corporation. Reprinted by permission.

Figure B13. Multiple-Task Floor Robot.

APPENDIX C: Masonry Construction Automation Technologies

- 1 - Robot Layer
- 2 - Crane Loader
- 3 - Mortar Generator
- 4 - Brick Carrier Truck
- 5 - Intermediate supply of bricks

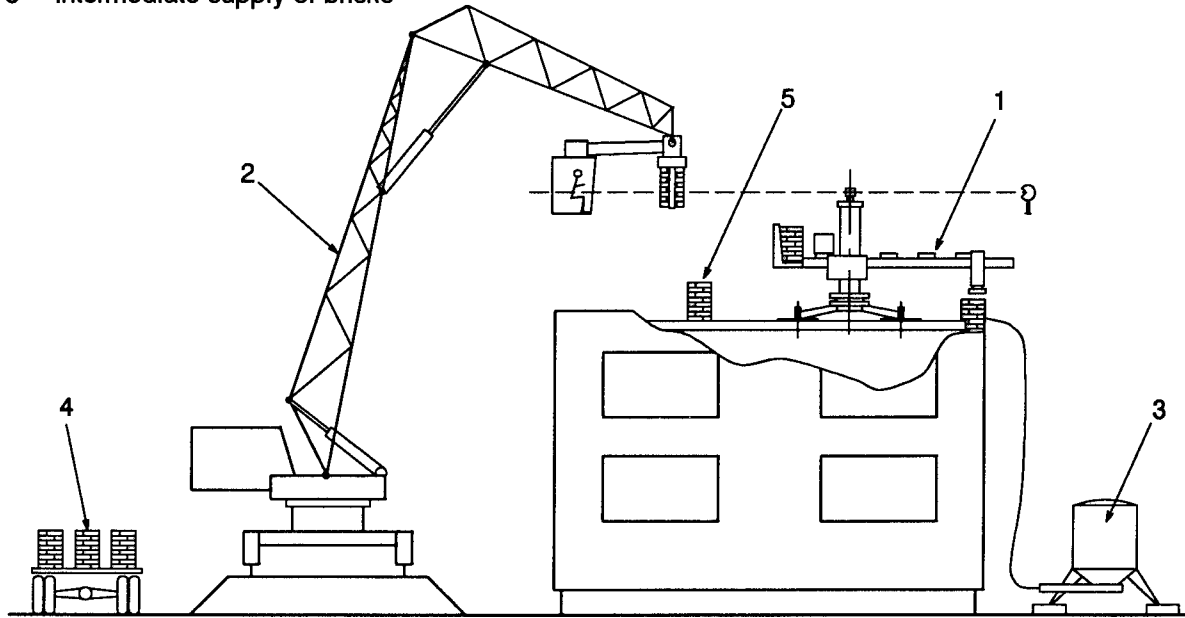

- 1 - Working member
- 2 - Feeder
- 3 - Extruder
- 4 - Supply of bricks
- 5 - Laser source of navigation system
- 6 - Reflector

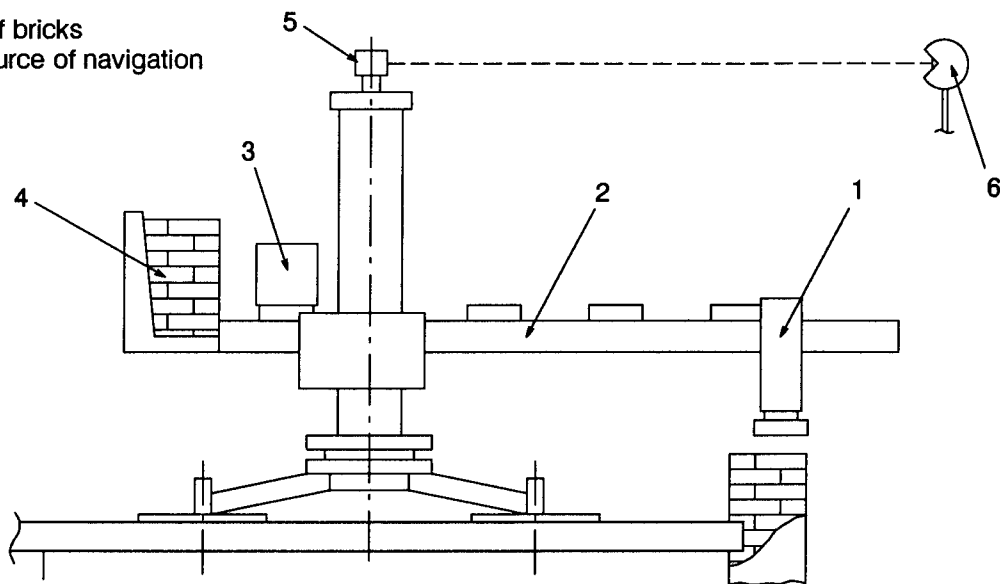
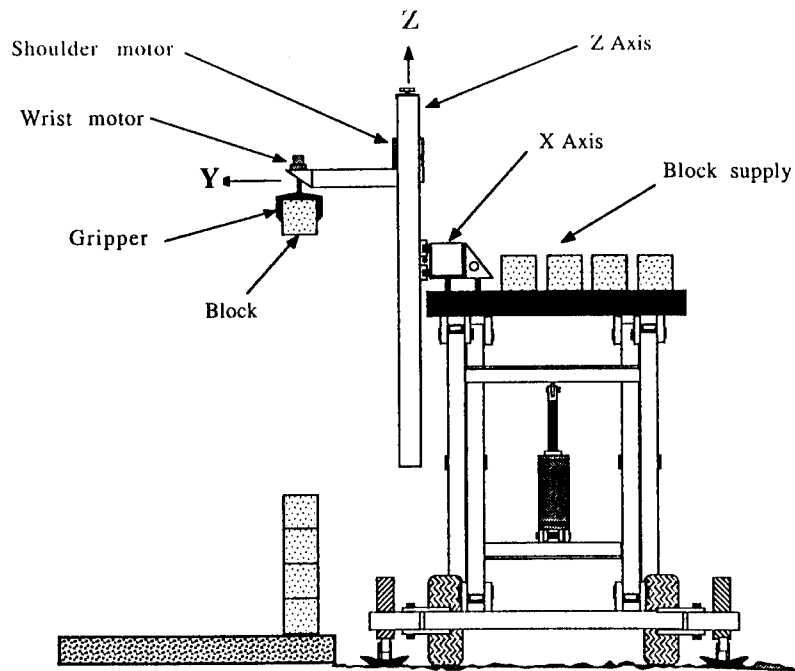
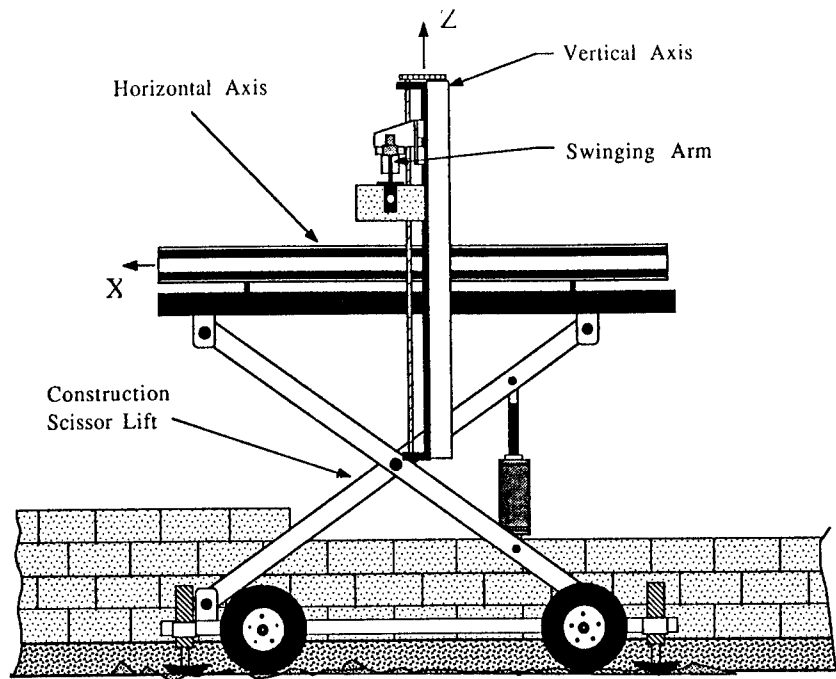

Figure C1. Masonry Robot Complex.



Source: Malinovsky, E. Yu, et al., "A Robotic Complex for Brick-Laying Applications," *Proceedings of the Seventh Symposium on Automation and Robotics in Construction*, ©June 1990, The All-Union Research Institute of Construction and Road-Building Machinery. Reprinted by permission.

Figure C2. Blockbot.

APPENDIX D: Steel Construction Automation Technologies

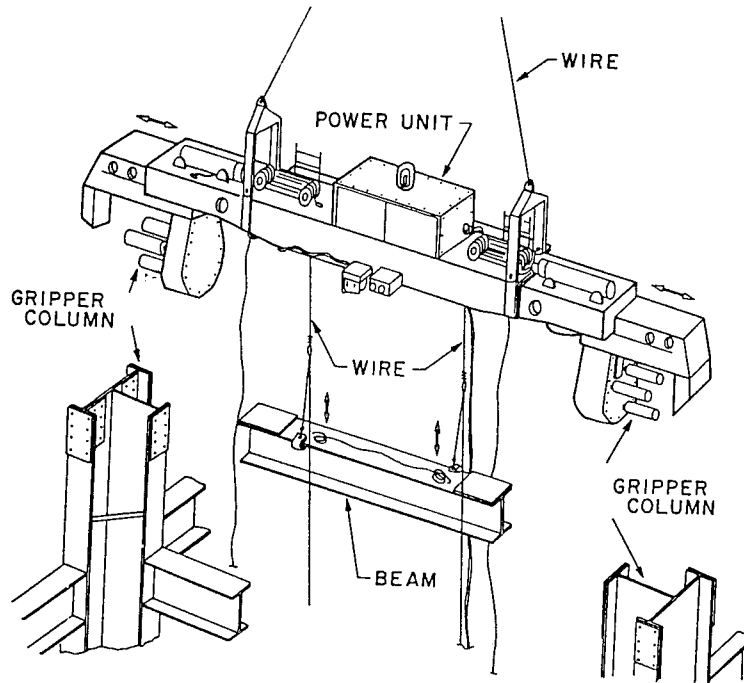

Source: This figure is from SME Technical Paper MS89-271, used by permission of the Society of Manufacturing Engineers, ©1989, from the 1989 World Conference on Robotics Research: The Next Five Years and Beyond Proceedings.

Figure D1. Mighty Jack.

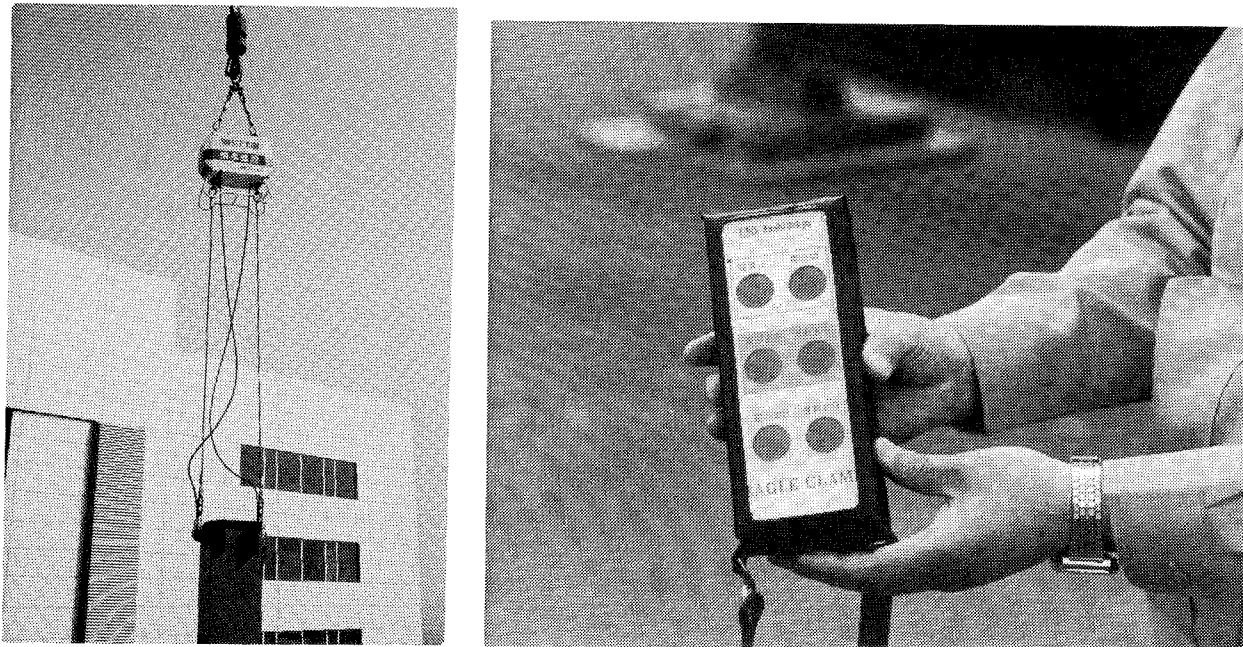

Source: Shimizu Corporation. Reprinted by permission.

Figure D2. Mighty Shackle Ace.

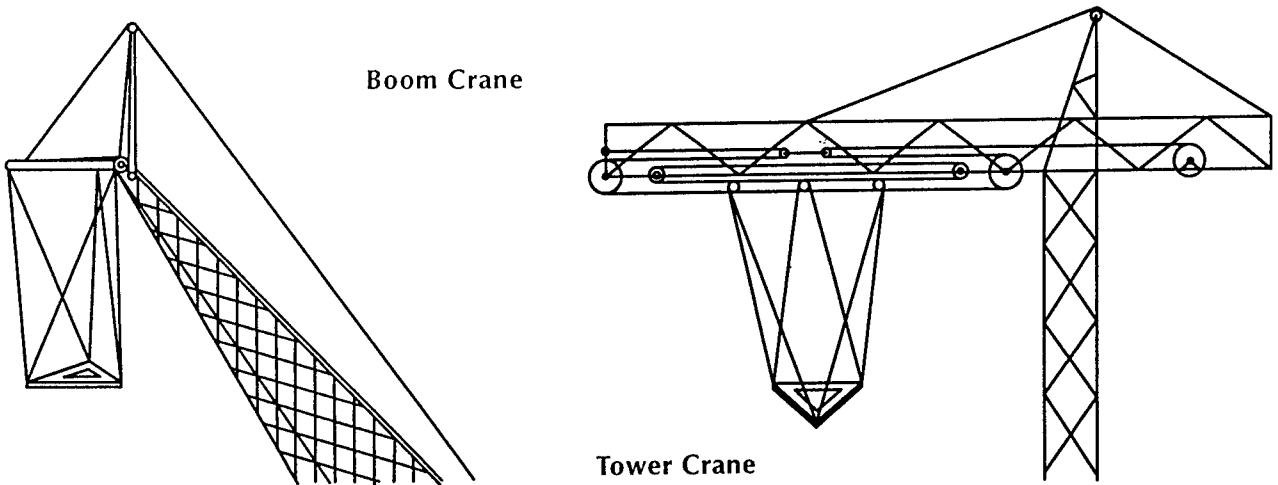
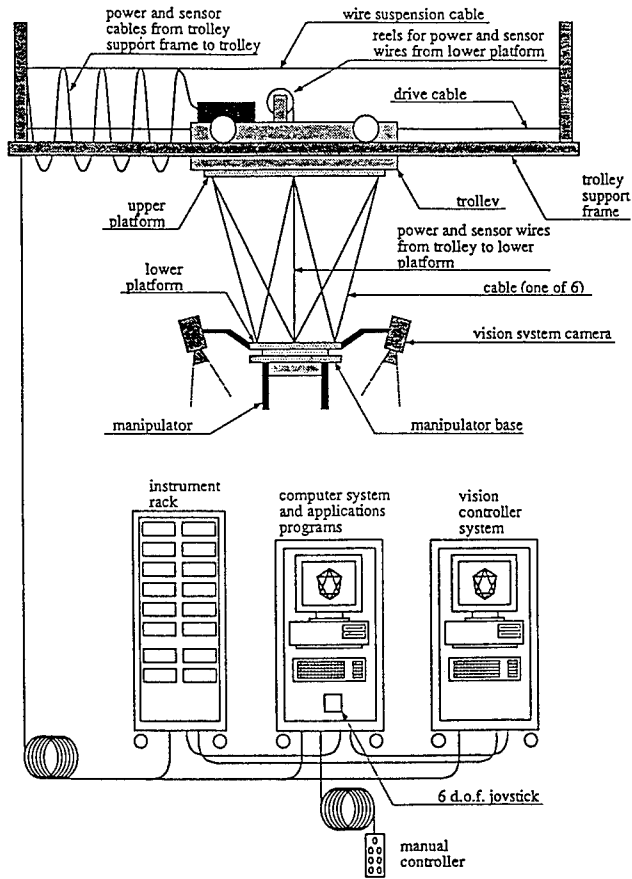

Figure D3. ACES.

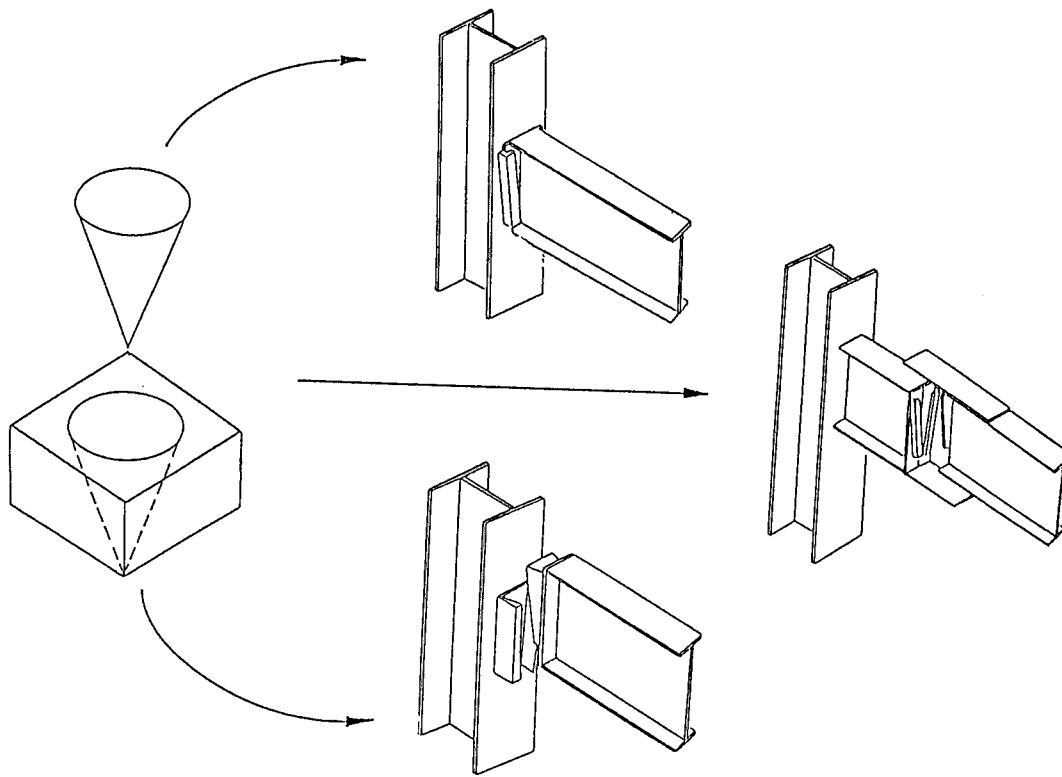
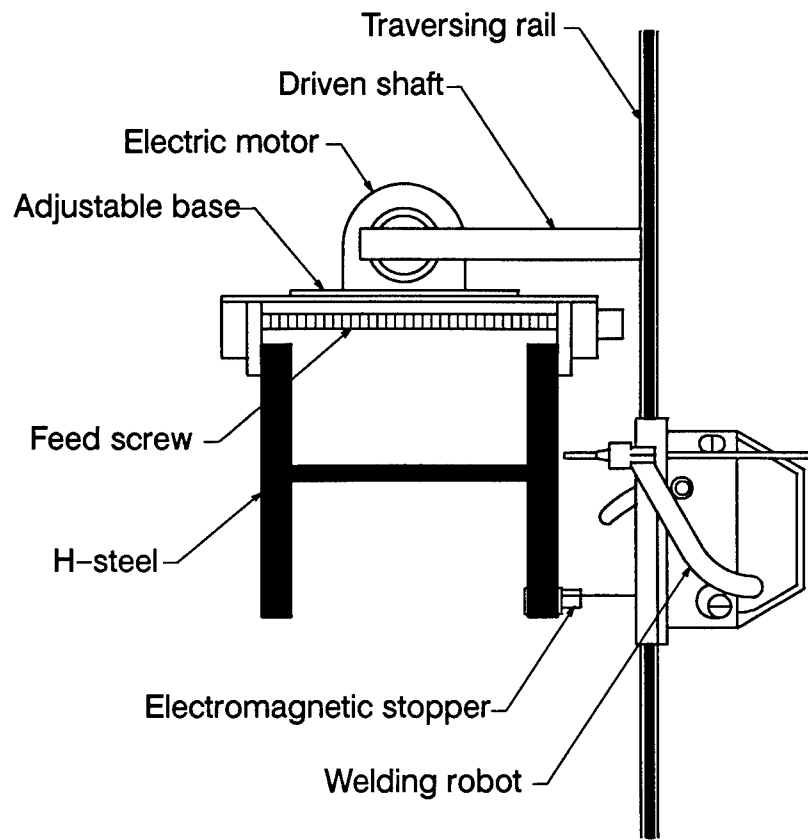

Figure D4. ATLSS Connection.



Source: Fujita Corporation. Reprinted by permission.

Figure D5. Onsite Welding System.

APPENDIX E: Comprehensive Automated Building Systems

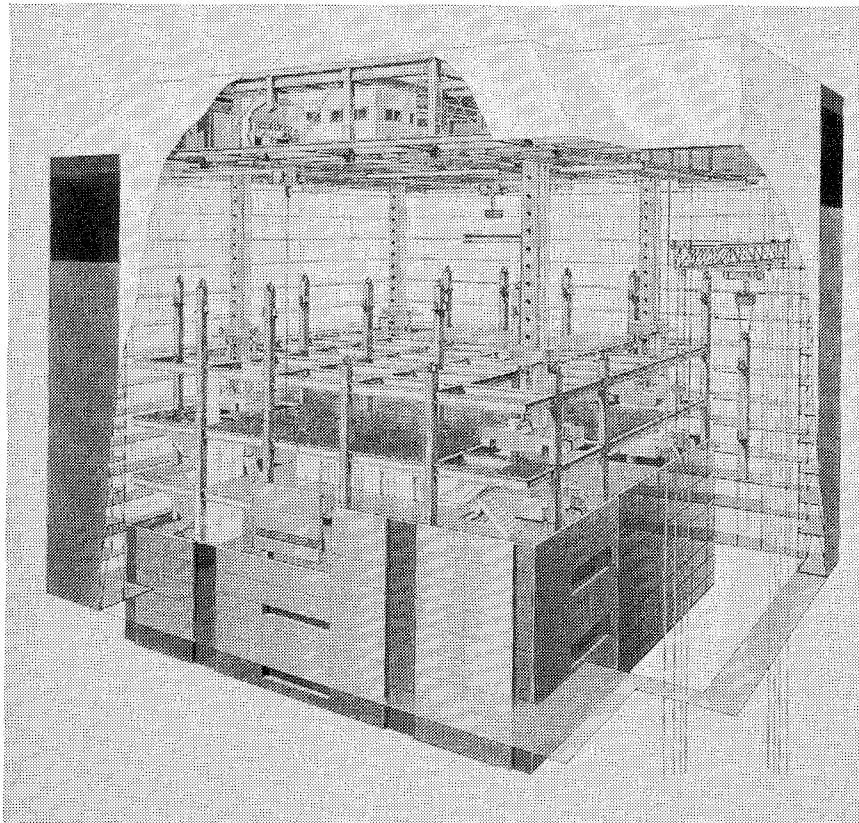

Source: Shimizu Corporation. Reprinted by permission.

Figure E1. SMART System.

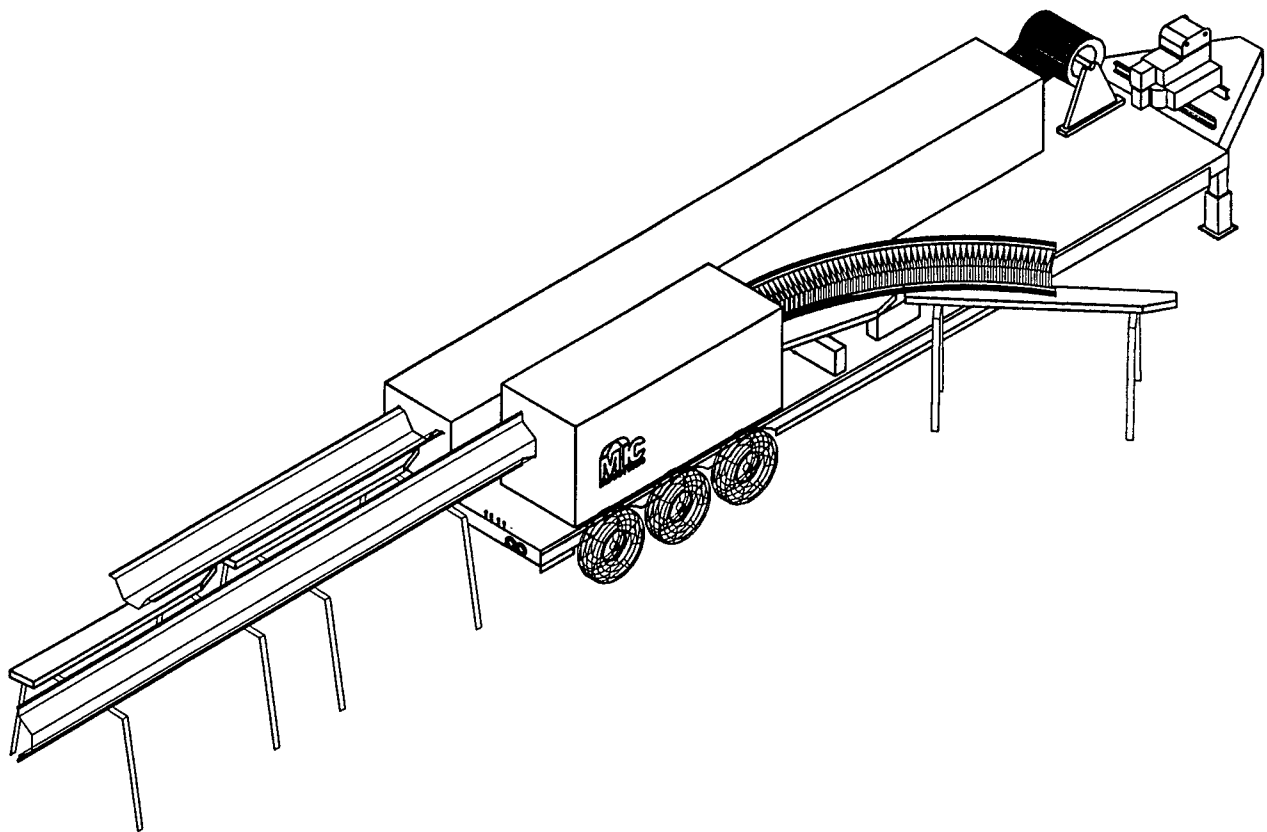
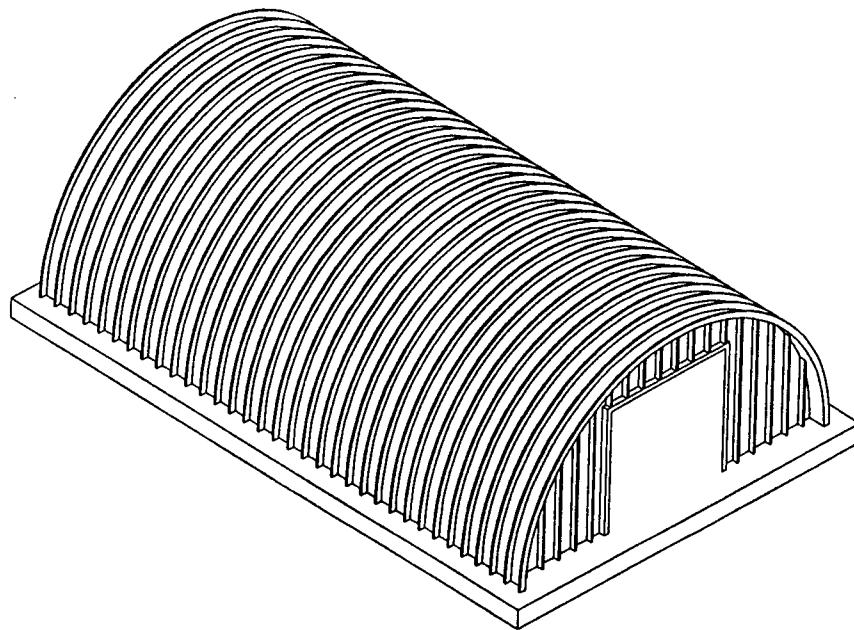

Figure E2. Automatic Building Machine (ABM)

APPENDIX F: Possible NDE Technologies for Construction Automation QA

Ground-Penetrating Radar and Magnetic Sensors for Sitework QA Magnetic Sensors for Evaluating Placement of Reinforcement Materials

Portable battery-operated magnetic devices (cover meters) that use magneto induction can measure the depth of steel reinforcement materials in concrete. The probe consists of a coil that carries an alternating current through it to induce a magnetic field between two faces of the probe. The device is moved over the concrete, and if the magnetic field passes through reinforcement, the induced secondary current is controlled by the reinforcement. The inductance change is measured by the meter, which indicates large readings of inductance changes as shallow reinforcing depths (Clifton, Carino, and Howdysshell, March 1982).

The usefulness of cover meters is limited because their readings are being highly directional: the readings are the greatest if the probe is directly above and aligned with the reinforcing steel, but as the probe is moved away, the readings lessen. In addition to this, miscellaneous items in the concrete may affect the accuracy of the measurement. Study items include steel form ties, wire ties for reinforcement support, aggregates with magnetic characteristics, etc. Accuracy also is adversely affected by temperatures below freezing. Measurement accuracy may also be affected by reinforcement spacing of less than 5 or 6 in. Finally, the power required by the device may restrict the testing duration (Malhotra 1984).

Recently developed cover meters can compensate for temperature variations and magnetic aggregates, distinguish between horizontal and vertical reinforcing bars, and detect single bars within groups of parallel reinforcement (McDonald 1991).

Penetrating Radar for Detecting Reinforcement Placement and Voids in Concrete

This method measures the electromagnetic waves reflected off of boundaries between two media having highly contrasting dielectric properties, such as air to concrete, concrete to steel reinforcing, concrete to void, void to concrete, concrete to base, base to subgrade, or subgrade to earth. The transducers—a combined transmitter and receiver—send electromagnetic energy pulses every nanosecond at a frequency of 1 GHz to penetrate about 3 ft, and offer the best possible resolution. The readings are processed and sent to a line-scan graphic recorder to become a graphic representation depicting the locations and relative depths of the voids or reinforcing (Clemena, Sprinkel, and Long 1987; Okamoto 1988). One problem with ground-penetrating radar is that the readings are time-dependent: if an inspector suddenly slows movement of the sensing device, an object sensed will appear larger than it actually is. This problem could be solved by automating the movement of the sensing device, but such machines are not yet commercially available.

Acoustic Impact for Detecting Voids in Building Materials

The oldest and simplest method for detecting voids is acoustic inspection, in which audible test waves produced by mechanical impact are used to detect subsurface voids. In practice, a transducer is attached to the concrete, and an amplifier and display unit are used to produce a visual display of the frequency and damping characteristics of the “ringing.” Comparing the actual output with an acceptable example can indicate the presence of voids. A method similar to this is used in Japan, by firms such as Ohbayashi and Kajima Corporation, to detect loose or broken wall tiles. The one limitation of this system is that an experienced operator is required to conduct the inspection because of the variance of the “ringing” caused by different test-object masses and geometries (Clifton, Carino, and Howdysshell, March 1982).

Ultrasonic Pulse-Echo for Detecting Voids and Concrete Thickness

This method measures ultrasonic waves reflected off material interfaces (e.g., concrete and reinforcing) or discontinuities such as cracks or voids. The inspection probe contains both the transmitting and receiving transducers, so only waves reflected back at about 180 degrees are detected. Higher-frequency waves produce better sensitivity, but cannot penetrate concrete as well as lower-frequency waves. This technique has been used mainly for the inspection of metals—not concrete—because concrete's extensive pore system, presence of cracking, and heterogeneous nature creates multiple reflections when very high frequencies are used. In 1991, scientists at the U.S. Army Engineer Waterways Experiment Station (USAWES) adapted the ultrasonic pulse-echo technique to concrete by developing specialized hardware and software. Detection of voids and concrete depth by ultrasonic pulse-echo is accurate to depth of 1 ft. Research at USAWES is ongoing to develop a system that can penetrate over 10 ft of concrete (Alexander 1991).

Limitations of ultrasonic ranging devices include that the speed of sound is temperature-dependent, certain surface characteristics can cancel a single-frequency waveform, and a large beam width can cause incorrect readings. A wide beam can make a rebar appear much wider than it actually is. Also, if adequate contact between the detection device and the concrete surface is not made, the readings may be inaccurate. The inspector must have a thorough understanding of the interactions between acoustic waves and different discontinuities to interpret the test results properly.

ABBREVIATION AND ACRONYMS

AASHTO	American Association of State Highway and Transportation Officials
ABM	Automated Building Machine
ACES	automated crane erection system
AFB	Air Force Base
AFCESA	Air Force Civil Engineering Support Agency
ASTM	American Society for Testing and Materials (obsolete—ASTM is now the organization's official name)
ATLSS	Advanced Technology for Large Structural Systems
ATR	Advanced Technologies Research
BPU	Binder Placement Unit
CAD	Computer-aided drafting
CII	Construction Industry Institute
CMU	concrete masonry unit
CPAR	Construction Productivity Advancement Research
EP	Engineer Pamphlet
EPA	Environmental Protection Agency
FAA	Federal Aviation Administration
GPS	Global Positioning System
GIS	geographic information system
HCD	Horizontal Concrete Distribution
IMI	International Masonry Institute
ITW	Illinois Tool Works
MAMA	Mechanically Assisted Mason's Aid
MIT	Massachusetts Institute of Technology
mph	miles per hour
NATM	New Australia Tunneling Method

NDE	nondestructive evaluation
NFS	National Science Foundation
OSHA	Occupational Safety and Health Administration
QA	quality assurance
QA/CQC	Quality Assurance/Contractor Quality Control
R&D	research and development
ReCUS	Remotely Controlled Underwater Surveyor
REX	Robot Excavator
ROME	Remotely Operated Mechanical Excavator
RRR	Rapid Runway Repair
SMART	Shimizu Manufacturing System by Advanced Robotic Technology
SSS-G	Cast-In-Situation Substructure System Giant
TORCE	Teleoperated Remote Control Excavator
USACE	U.S. Army Corps of Engineers
USACERL	U.S. Army Construction Engineering Research Laboratories
USATEC	U.S. Army Topographic Engineering Center
USAWES	U.S. Army Waterways Experiment Station
WASCOR	Waseda Construction Robot
w/c	water-to-cement (ratio)

USACERL DISTRIBUTION

Chief of Engineers
 ATTN: CEHEC-IM-LH (2)
 ATTN: CEHEC-IM-LP (2)
 ATTN: CECG
 ATTN: CECC-P
 ATTN: CECW
 ATTN: CECW-O
 ATTN: CECW-P
 ATTN: CECW-PR
 ATTN: CEMP
 ATTN: CEMP-E
 ATTN: CEMP-C
 ATTN: CEMP-M
 ATTN: CEMP-R
 ATTN: CERD-C
 ATTN: CERD-ZA
 ATTN: CERD-L
 ATTN: CERD-M
 ATTN: CERM
 ATTN: DAEN-ZC
 ATTN: DAIM-FDP

CECPW 22310-3862
 ATTN: CECPW-E
 ATTN: CECPW-FT
 ATTN: CECPW-ZC
 ATTN: DET III 79906

US Army Engr District
 ATTN: Library (40)

US Army Engr Division
 ATTN: Library (12)

US Army Europe
 ATTN: AEAEN-EH 09014
 ATTN: AEAEN-ODCS 09014
 29th Area Support Group
 ATTN: AERAS-FA 09054
 100th Support Group
 ATTN: AETT-EN-DPW 09114
 222d Base Battalion
 ATTN: AETV-BHR-E 09034
 235th Base Support Battalion
 ATTN: Unit 28614 Ansbach 09177
 293d Base Support Battalion
 ATTN: AEUSG-MA-AST-WO-E 09086
 409th Support Battalion (Base)
 ATTN: AETTG-DPW 09114
 412th Base Support Battalion 09630
 ATTN: Unit 31401
 Frankfurt Base Support Battalion
 ATTN: Unit 25727 09242
 CMTC Hohenfels 09173
 ATTN: AETTH-DPW
 Mainz Germany 09185
 ATTN: BSB-MZ-E
 21st Support Command
 ATTN: DPW (10)
 US Army Berlin
 ATTN: AEBA-EH 09235
 ATTN: AEBA-EN 09235
 SETAF
 ATTN: AESE-EN-D 09613
 ATTN: AESE-EN 09630
 Supreme Allied Command
 ATTN: ACSGEB 09703
 ATTN: SHIHB/ENGR 09705

INSCOM
 ATTN: IALOG-I 22060
 ATTN: IAV-DPW 22186

USA TACOM 48397-5000
 ATTN: AMSTA-XE

Defense Distribution Region East
 ATTN: DDRE-WI 17070

HQ XVIII Airborne Corps 28307
 ATTN: AFZA-DPW-EE

4th Infantry Div (MECH) 80913-5000
 ATTN: AFZC-FE

US Army Materiel Command (AMC)
 Alexandria, VA 22333-0001
 ATTN: AMCEN-F
 Installations: (19)

FORSCOM
 Forts Gillem & McPherson 30330
 ATTN: FCEN
 Installations: (23)

6th Infantry Division (Light)
 ATTN: APVR-DE 99505
 ATTN: APVR-WF-DE 99703

TRADOC
 Fort Monroe 23651
 ATTN: ATBO-G
 Installations: (20)

Fort Belvoir 22060
 ATTN: CECEC-IM-T
 ATTN: CECC-R 20314-1000
 ATTN: Engr Strategic Studies Ctr
 ATTN: Water Resources Support Ctr
 ATTN: Australian Liaison Office

USA Natick RD&E Center 01760
 ATTN: STRNC-DT
 ATTN: DRDNA-F

US Army Materials Tech Lab
 ATTN: SLCMT-DPW 02172

USARPAC 96858
 ATTN: DPW
 ATTN: APEN-A

SHAPE 09705
 ATTN: Infrastructure Branch LANDA

Area Engineer, AEDC-Area Office
 Arnold Air Force Station, TN 37389

HQ USEUCOM 09128
 ATTN: ECJ4-LIE

AMMRC 02172
 ATTN: DRXMR-AF
 ATTN: DRXMR-WE

CEWES 39180
 ATTN: Library

CECRL 03755
 ATTN: Library

USA AMCOM
 ATTN: Facilities Engr 21719
 ATTN: AMSMC-EH 61299
 ATTN: Facilities Engr (3) 85613

USAARMC 40121
 ATTN: ATZIC-EHA

Military Traffic Mgmt Command
 ATTN: MTEA-GB-EHP 07002
 ATTN: MT-LOF 20315
 ATTN: MTE-SU-FE 28461
 ATTN: MTW-IE 94626

Fort Leonard Wood 65473
 ATTN: ATSE-DAC-LB (3)
 ATTN: ATZA-TE-SW
 ATTN: ATSE-CFLO
 ATTN: ATSE-DAC-FL

Military Dist of WASH
 Fort McNair
 ATTN: ANEN 20319

USA Engr Activity, Capital Area
 ATTN: Library 22211

US Army ARDEC 07806
 ATTN: SMCAR-ISE

Engr Societies Library
 ATTN: Acquisitions 10017

Defense Nuclear Agency
 ATTN: NADS 20305

Defense Logistics Agency
 ATTN: DLA-WI 22304

Walter Reed Army Medical Ctr 20307

National Guard Bureau 20310
 ATTN: NGB-ARI

US Military Academy 10996
 ATTN: MAEN-A
 ATTN: Facilities Engineer
 ATTN: Geography & Envr Engrg

Naval Facilities Engr Command
 ATTN: Facilities Engr Command (8)
 ATTN: Division Offices (11)
 ATTN: Public Works Center (8)
 ATTN: Naval Constr Battalion Ctr 93043
 ATTN: Naval Facilities Engr Service Center 93043-4328

8th US Army Korea
 ATTN: DPW (12)

USA Japan (USARJ)
 ATTN: APAJ-EN-ES 96343
 ATTN: HONSHU 96343
 ATTN: DPW-Okinawa 96376

416th Engineer Command 60623
 ATTN: Gibson USAR Ctr

US Army HSC
 Fort Sam Houston 78234
 ATTN: HSLO-F
 Fitzsimons Army Medical Ctr
 ATTN: HSHG-DPW 80045

Tyndall AFB 32403
 ATTN: HQAFCEA Program Ofc
 ATTN: Engrg & Svc Lab

USA TSARCOM 63120
 ATTN: STSAS-F

American Public Works Assoc. 64104-1806

US Army Envr Hygiene Agency
 ATTN: HSHB-ME 21010

US Gov't Printing Office 20401
 ATTN: Rec Sec/Deposit Sec (2)

Nat'l Institute of Standards & Tech
 ATTN: Library 20899

Defense Tech Info Center 22304
 ATTN: DTIC-FAB (2)

283
794