

# The Effect of Wear on Fire-Blocking Layer Material Effectiveness

J. Michael Barrientos

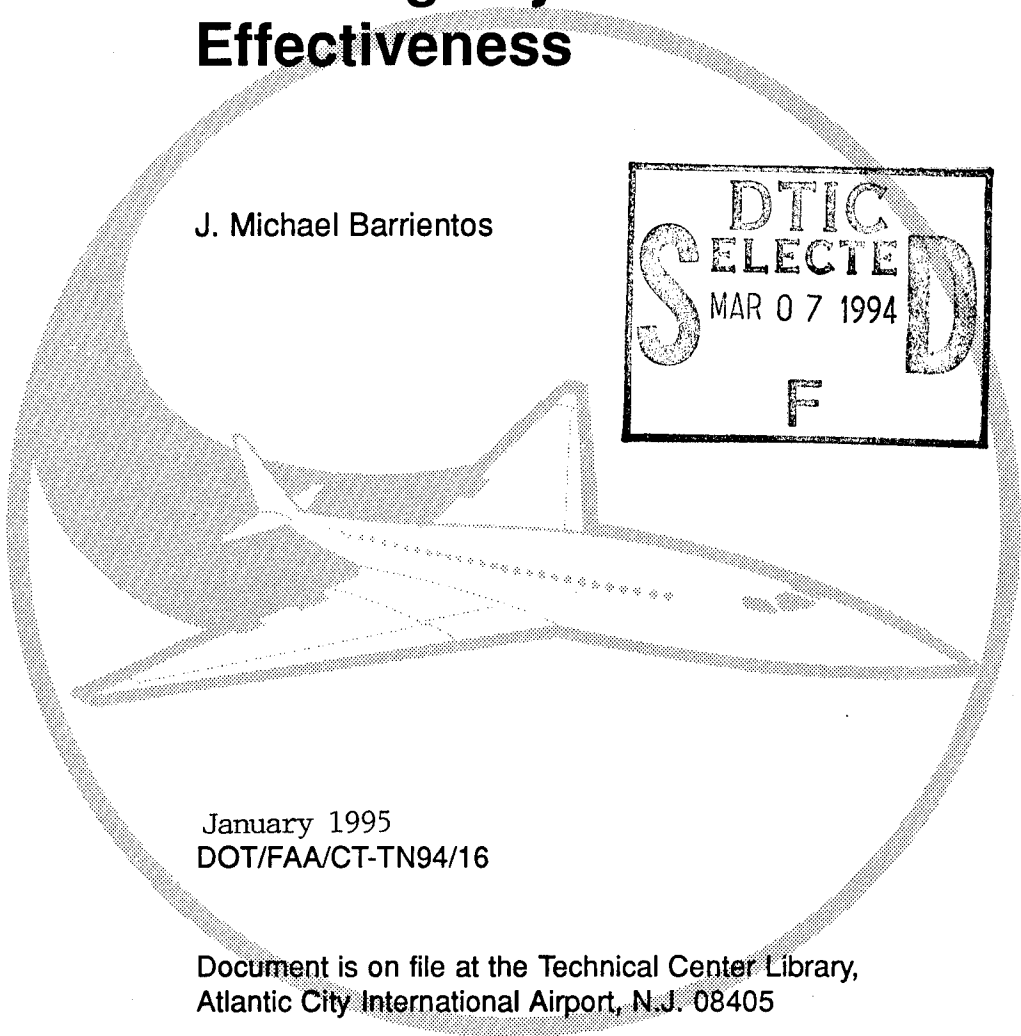
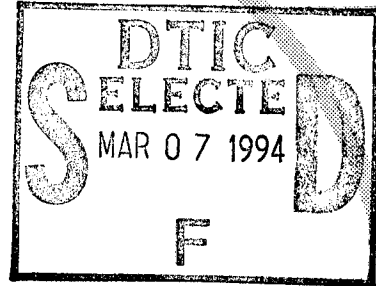

January 1995  
DOT/FAA/CT-TN94/16

Document is on file at the Technical Center Library,  
Atlantic City International Airport, N.J. 08405

This document has been approved  
for public release and sale; its  
distribution is unlimited.

19950228 002



U.S. Department of Transportation  
Federal Aviation Administration

Technical Center  
Atlantic City Airport, NJ 08405

DTIC QUALITY INSPECTION

#### NOTICE

This document is disseminated under the sponsorship of the U. S. Department of Transportation in the interest of information exchange. The United States Government assumes no liability for the contents or use thereof.

The United States Government does not endorse products or manufacturers. Trade or manufacturers' names appear herein solely because they are considered essential to the objective of this report.

Technical Report Documentation Page

1. Report No. DOT/FAA/CT-TN94/16		2. Government Accession No.		3. Recipient's Catalog No.	
4. Title and Subtitle The Effect of Wear on Fire-Blocking Layer Material Effectiveness				5. Report Date January 1995	
				6. Performing Organization Code ACD-240	
7. Author(s) J. Michael Barrientos				8. Performing Organization Report No. DOT/FAA/CT-TN94/16	
9. Performing Organization Name and Address Federal Aviation Administration Technical Center Atlantic City International Airport, NJ 08405				10. Work Unit No. (TRAIS)	
				11. Contract or Grant No.	
12. Sponsoring Agency Name and Address U.S. Department of Transportation Federal Aviation Administration Technical Center Atlantic City International Airport, NJ 08405				13. Type of Report and Period Covered Technical Note	
				14. Sponsoring Agency Code	
15. Supplementary Notes					
16. Abstract <p>On April 6, 1993, China Airline's MD-11 Flight 583 underwent severe turbulence caused by the inadvertent deployment of the wing leading edge slats. The aircraft experienced three violent pitch oscillations and a loss of altitude of about 5,000 feet which significantly damaged the interior of the cabin. Upon examination of the passenger seats in the cabin interior, excessive wear was noticed with the fire-blocking layer (FBL) material which encapsulates the foam cushions that protect them in the event of a fire. Concerns arose with this FBL material manufactured by Testori of Italy, as well as other FBL material in service, with regard to their effectiveness in protecting the foam cushions from fire. Samples of this type of material underwent several flammability tests at the FAA Technical Center International Airport, NJ, and chemical analysis and microscopic examination at Du Pont Fibers Laboratory in Wilmington, Delaware.</p>					
17. Key Words Fire-blocking layer Flammability Oil burner test Specimen sets Squirring Herman			18. Distribution Statement Document is on file at the Technical Center Library, Atlantic City International Airport, New Jersey 08405		
19. Security Classif. (of this report) Unclassified		20. Security Classif. (of this page) Unclassified		21. No. of Pages 19	22. Price

## TABLE OF CONTENTS

	Page
<b>EXECUTIVE SUMMARY</b>	v
<b>INTRODUCTION</b>	1
Purpose	1
Background	1
<b>DISCUSSION</b>	2
Tests Performed	2
<b>CONCLUSION</b>	11
<b>REFERENCES</b>	12
<b>GLOSSARY</b>	13

Accession For	
NTIS CRA&I	<input checked="" type="checkbox"/>
DTIC TAB	<input type="checkbox"/>
Unannounced	<input type="checkbox"/>
Justification .....	
By .....	
Distribution /	
Availability Code	
Dist	Availability Code
A-1	

## LIST OF ILLUSTRATIONS

<b>Figure</b>		<b>Page</b>
1	<b>Standard Seat Cushion Specimen Set for Oil Burner Testing</b>	3
2	<b>Boeing's "Squirming Herman" Test Apparatus</b>	6
3	<b>Testori FBL Material 1 After Exposure to the "Squirming Herman"</b> (From China Eastern Airline's MD-11 seats)	8
4	<b>Testori FBL Material 2 After Exposure to the "Squirming Herman"</b> (From Trans World Express's ATR-42 seats)	9

## LIST OF TABLES

<b>Table</b>		<b>Page</b>
1	<b>Oil Burner Test Results (Tests 1-5)</b>	4
2	<b>Testori Material Examined at Du Pont</b>	5
3	<b>Wear Test Results on Testori Materials</b>	7
4	<b>Flammability Tests Results On Wear Tested Seats</b> (From China Eastern Airline's MD-11 seats)	10
5	<b>Flammability Test Results On Wear Tested Seats</b> (From TWE's ATR-42 seats)	10

## EXECUTIVE SUMMARY

On April 6, 1993, China Eastern Airline's MD-11 Flight 583 underwent severe turbulence caused by the inadvertent deployment of the wing leading edge slats. The aircraft experienced three violent pitch oscillations and a loss of altitude of about 5,000 feet which significantly damaged the interior of the cabin. Upon examination of the passenger seats in the cabin interior, excessive wear was noticed with the fire-blocking layer (FBL) material which encapsulates the foam cushions that protect them in the event of a fire. Concerns arose with this FBL material manufactured by Testori of Italy, as well as other FBL material in service, with regard to their effectiveness in protecting the foam cushions from fire. Samples of this type of material underwent several flammability tests at the FAA Technical Center at Atlantic City International Airport, NJ, and chemical analysis and microscopic examination at Du Pont Fibers Laboratory in Wilmington, Delaware.

## INTRODUCTION

### PURPOSE.

The purpose of this study was to determine the effect of service wear on the effectiveness of seat cushion fire-blocking layer material (FBL). In this particular case, the material in question was a fabric manufactured by Testori of Italy, however, this concern would also apply to all FBL material in service.

### BACKGROUND.

Nine hundred and fifty miles south of Shemya, Alaska, on April 6, 1993, China Eastern Airline's MD-11 Flight 583 encountered three violent pitch oscillations and a loss of altitude of about 5,000 feet caused by the inadvertent deployment of the wing leading edge slats. As a result of the severe turbulence, extensive damage occurred in the cabin. Of the 20 crewmembers and 235 passengers onboard, 3 flight crewmembers; 3 flight attendants; and 151 passengers suffered serious and minor injuries. One passenger died before the aircraft landed and a second passenger died one week later in the hospital. The National Transportation Safety Board determined that inadequate design of the flap/slat actuation handle was the probable cause of the accident. The poor design allowed the handle to be easily and inadvertently dislodged from the UP/RET position, thereby causing extension of the leading edge slats during cruise flight (reference 1).

During the investigation of the cabin area, it was noticed upon examination of the passenger seats that there was excessive wear of the fire-blocking layer material (FBL). The FBL material is used to encapsulate the foam cushion thus protecting it in the event of a fire, possibly caused by an accident or a terroristic attack. The passenger seats were manufactured by SICMA Aero-Seat of Paris, France. The FBL in question was a material manufactured by Testori of Italy. Concerns arose with how well this FBL, as well as those presently in service, would protect the foam cushion from a fire after so many years in service.

Under FAR Part 25, appendix F - part II, the FBL in seat cushion specimens must be able to demonstrate it passes the Oil Burner Seat Cushion Test before it can be certified to be used onboard an aircraft. However, there is no test requirement to account for the effect of service wear and tear. After so many hours in service, FBL's protective characteristics may be diminished to some degree due to wear, beverage and food spillage, human sweat, humidity, and dry-cleaning. An IA (an FAA certified A & P mechanic authorized for an Inspection Authorization) conducting an annual or progressive inspection might take off a dress cover, examine the materials, and based on appearance, conclude that the FBL would be as effective as the day it was installed.

## DISCUSSION

### TESTS PERFORMED.

Concerns with wear on fire-blocking layer material effectiveness was examined at the request of the NTSB at the FAA Technical Center on May 17, 1993. Actual seat cushion specimens that were onboard Flight 583 were sent to the Fire Safety Branch for flammability testing in compliance with FAR 25, part II of appendix F. In this test, three sets of seat cushions (back and bottom) were exposed for two minutes to a high intensity flame produced by an oil burner at a specified distance and temperature. The criteria for passing the Oil Burner Test for Seat Cushion Specimens are as follows:

1. The burn length does not exceed 17 inches from two of the three specimen sets tested
2. The average weight loss does not exceed 10 percent.
3. The weight loss of two of the three specimen sets tested must not exceed 10 percent.

(See Glossary for definitions on burn length, weight loss, specimen set, etc., reference 2).

Most of the materials recovered from the aircraft accident were too worn or shredded to fabricate three specimen sets in compliance with the regulation size for flammability testing (see figure 1 for specimen regulation size). For this reason, it was decided only one set would be tested. The test results proved that the cushions (back and bottom) failed on two accounts:

1. Burn length exceeded 17 inches
2. Weight loss exceeded 10 percent

See table 1 for further details on May 17, 1993, test results.

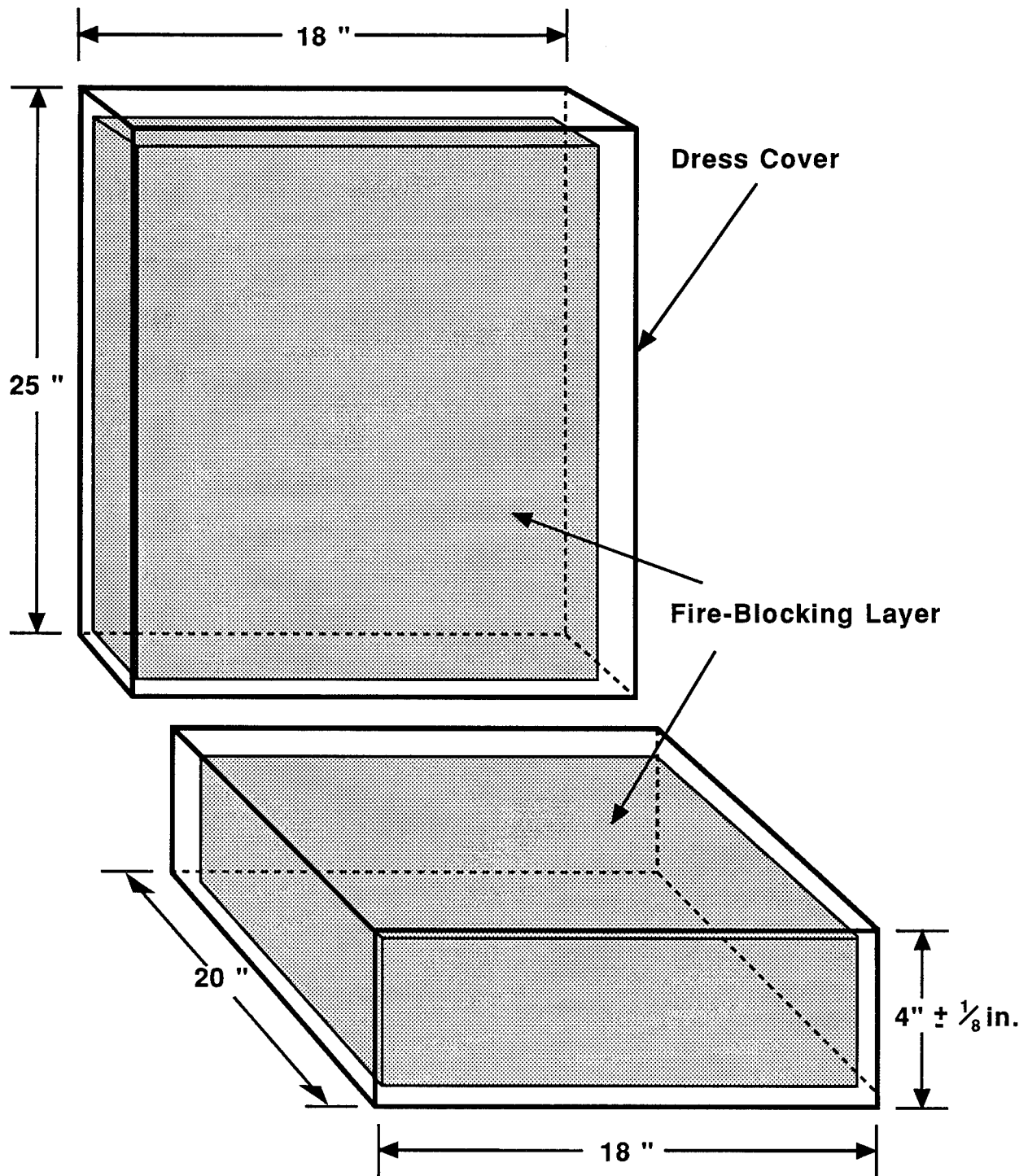

FIGURE 1. STANDARD SEAT CUSHION SPECIMEN SET READY FOR OIL BURNER TESTING

Because the cushions failed the test and only one set was tested, SICMA Aero-Seat was requested to supply three sets of cushions made from the same material used onboard China Eastern Airline's Flight 583 and fabricated to the regulation size for testing as prescribed by FAR 25.853. A fourth specimen set which was removed from Trans World Express's (TWE) ATR-42 and sized to regulation specifications was also sent to the Technical Center for testing. SICMA Aero-Seat was also the manufacturer of TWE's passenger seat which incorporated Testori FBL. From test series 2 performed on June 16, 1993, the cushions (test numbers 2 & 3) failed the Oil Burner Test for Seat Cushion because two of the three specimen sets tested exceeded 10 percent weight loss. However, the burn lengths were within the allowed limits and the average weight loss did not exceed 10 percent. In test series 1A, the TWE cushion failed because it exceeded the weight loss limit requirement.

**TABLE 1. OIL BURNER TEST RESULTS (Tests 1-5)**

Test Date	Test	Pretest Weight	Postest Weight	WEIGHT LOSS		Description	Seat Mfg.	FBL Mfg.
				% Weight Loss	Specimen			
		2.52 lbs.	1.94 lbs.	23.00%	Back	<i>Cushions from</i>		
May 15, 1993	1	2.76 lbs.	2.08 lbs.	24.60%	Bottom	<i>China Eastern Airline's</i>	SICMA	Testori
(Test Series 1)		5.28 lbs.	4.02 lbs.	23.90%	Total	<i>Flight 583 Accident</i>		ref no. 200-316
	2	5.96 lbs.	5.36 lbs.	10.07%	Both	<i>Material used on</i>		
June 16, 1993	3	6.66 lbs.	5.98 lbs.	10.21%	Both	<i>China Eastern Airline's</i>		
(Test Series 2)	4	5.98 lbs.	5.40 lbs.	9.70%	Both	<i>Flight 583 &amp; fabricated</i>	SICMA	Testori
						<i>to regulation size</i>		ref no. 200-316
June 16, 1993	5	6.62 lbs.	5.72 lbs.	13.60%	Both	<i>Cushions from actual</i>	SICMA	Testori
(Test Series 1A)						<i>TWE's ATR-42</i>		ref no. 206-100
				<b>BURN LENGTH</b>				
			<b>Bottom Cushion Specimen</b>		<b>Back Cushion Specimen</b>			
		<b>Topside</b>	<b>Bottomside</b>		<b>Frontside</b>	<b>Backside</b>		
May 15, 1993	1	18 in.	0 in.		18 in.	0 in.		
	2	5 in.	10.5 in.		8.5 in.	0 in.		
June 16, 1993	3	5.5 in.	16.5 in.		10.5 in.	0 in.		
	4	5.5 in.	11 in.		8.0 in.	0 in.		
	5	13 in.	8.0 in.		17 in.	0 in.		

Three samples of Testori fire-blocking layer material were sent to Du Pont Fibers Laboratory in Wilmington, Delaware, on July 19, 1993, for microscopic examination and chemical analysis. Table 2 describes the material examined by Du Pont.

**TABLE 2. TESTORI MATERIAL EXAMINED AT DU PONT**

<i>SAMPLE</i>	<i>MATERIAL DESCRIPTION</i>	<i>REFERENCE No.</i>	<i>COMPOSITION</i>	<i>WEAVE PATTERN</i>
1	Testori FBL material removed from a China Eastern Airline's coach passenger seat which had been in service for two years	0200-316	70% Preox 30% Kevlar	Two-ply spun
2	Testori FBL material removed from Trans World Express's ATR-42 which had been in service for four years	0206-100	80% Carbon Fiber 20% Nomex	Two-lay spun
3	New Testori FBL material supplied by SICMA AERO-SEAT	0200-316	70% Preox 30% Kevlar	Continuous filament

Microscopic examination found that samples 1 and 2 were both constructed of a two-ply spun yarn while sample 3 was constructed from a continuous filament yarn. Du Pont stated that the two-ply yarn would possibly be expected to have less abrasion resistance and thus possibly less wear life. Du Pont also discovered a lubricating finish coated on all three material samples especially prevalent on sample 3. They indicated the finish was probably applied to the fabric to protect the brittle Preox (carbon fiber) material (reference 3).

Through the use of infrared microscopy and mass spectrometry techniques, chemical analysis was performed on the three samples. Du Pont observed certain stained areas of the fabric contained protein type polyamides and carbonmethyl cellulose salt particle/deposits that could not be removed with solvents (reference 3).

Wear testing was conducted on Testori materials to determine if wear on fire-blocking layer material changes its protective properties. These tests were conducted by Weber Aircraft in Gainesville, Texas, on July 27, 1993, using the Support Standard BSS-7302, also known as the "Squirring Herman", developed by Boeing (figure 2). The wear tester apparatus consisted of a buttocks shaped block which was in contact with the seat at 140 pounds of pressure for  $100 \pm 2$  seconds and withdrawn from the seat for  $20 \pm 2$  seconds completing the 2-minute cycle. The buttocks portion of the test apparatus underwent a 12 degree arc rocking motion and operated at 13-14 cycles/minute; the cushion then went through a 38-degree arc rotation at a 19.5 cycles/minute rate.

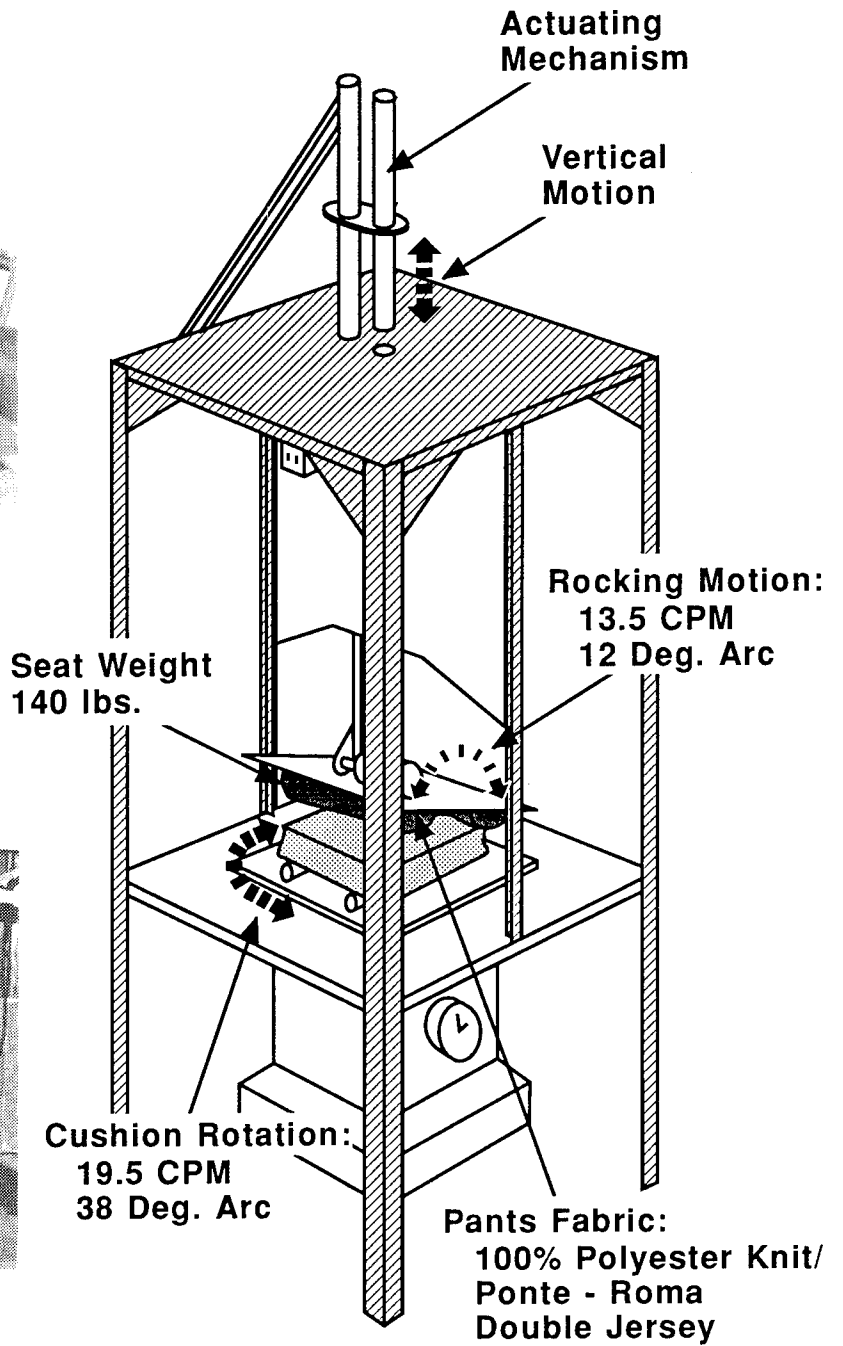
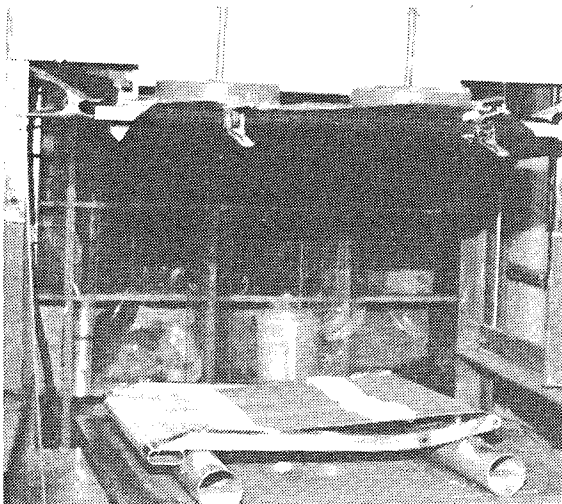
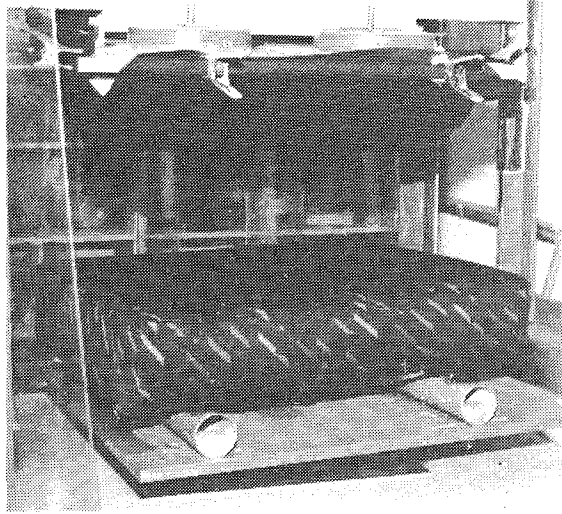

**2-Minute Cycle**  
**1-Minute 40-Seconds Contact on Cushion**  
**20-Seconds in Up Position**

FIGURE 2. BOEING'S "SQUIRMING HERMAN" TEST APPARATUS

The two sets of Testori materials were wear tested for 50, 25, and 10 hours. The first set of SICMA Aero-Seat materials were of the same type used on China Eastern Airline's MD-11s. The second set of cushions tested were materials SICMA Aero-Seat uses on passenger seats for Trans World Express's ATR-42. According to Boeing, 100 hours of wear testing was equivalent to about 5 years in service. In theory, the wear tests of the Testori materials corresponded to 2.5, 1.25, and 0.5 years in service. Table 3 illustrates the results of the wear tests on the two materials.

**TABLE 3. WEAR TEST RESULTS ON TESTORI MATERIALS** (Reference 2).

TESTORI SAMPLE	LENGTH OF EXPOSURE TIME ON THE "SQUIRMING HERMAN" (IN HOURS)		
	50	25	10
1	material was worn and very thin on top and bottom, discoloration of worn area from green to yellow	thinned on top and bottom, discoloration, two small holes found bottom side	slight wear and discoloration on top and bottom cushions
2	pillings found on top, thinning on both bottom and top	pillings found on top, less thinning area on bottom in comparison to the cushion exposed to the wear test for 50 hrs	less pillings on top with slight thinning

Figures 3 and 4 depict test series 3 and 2A (Weber Test nos.), respectively after exposure to the "Squirming Herman". Thinning of the FBL material was made more evident by observing the FBL against a light source. Light filtered quite easily through the thinned areas especially with the cushions that were wear tested longer. These cushions that underwent wear testing at Weber Aircraft were sent to the FAA Technical Center for flammability testing with the oil burner to determine what affect wear has on FBL's protective characteristics.

On August 18, 1993, all SICMA cushions were tested in accordance with FAR 25.853. The first series of flammability tests were conducted on seat cushions which are the same materials used on China Eastern Airline's MD-11. The results show, as can be seen in table 4, that there was no pattern associated with length of wear exposure and FBL's protective properties.

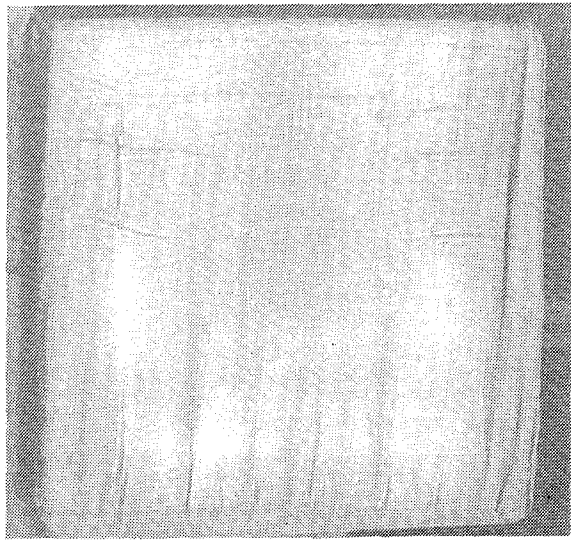

**50 Hours**

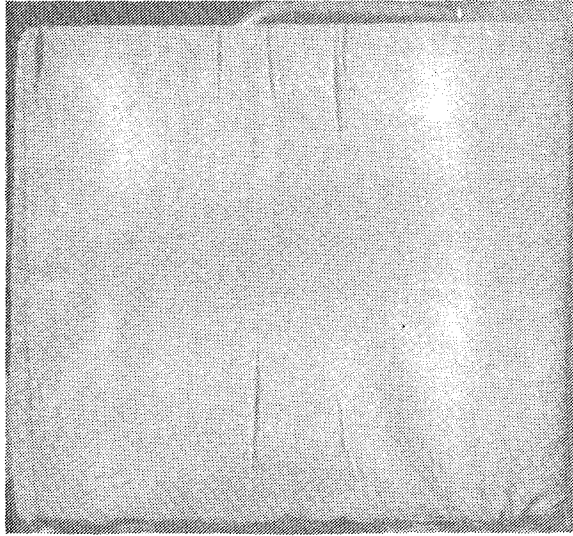
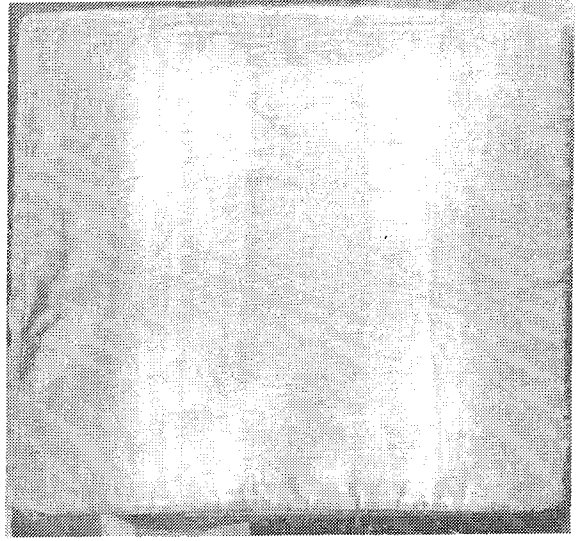

**25 Hours**

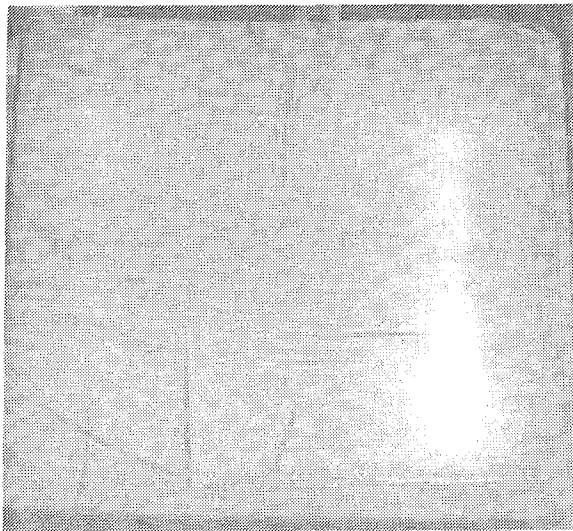
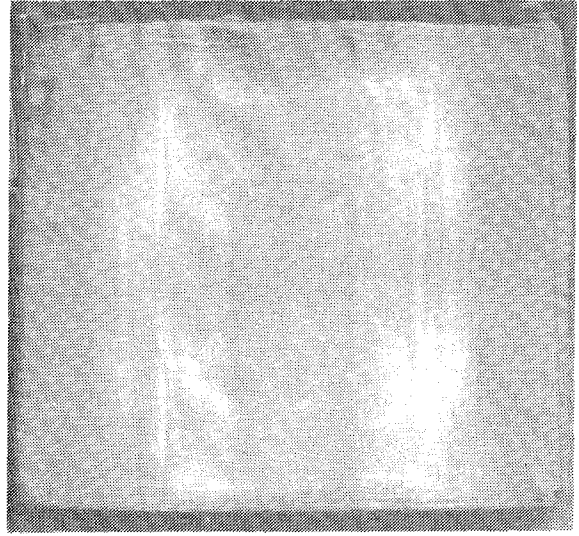

**10 Hours**

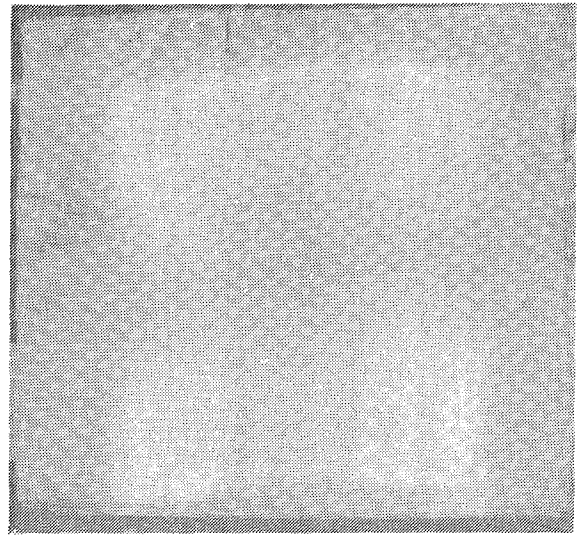

**Top**

**Bottom**

**FIGURE 3. TESTORI FBL MATERIAL 1 AFTER EXPOSURE TO THE "SQUIRMING HERMAN" (FROM CHINA EASTERN AIRLINE'S MD-11 SEATS)**

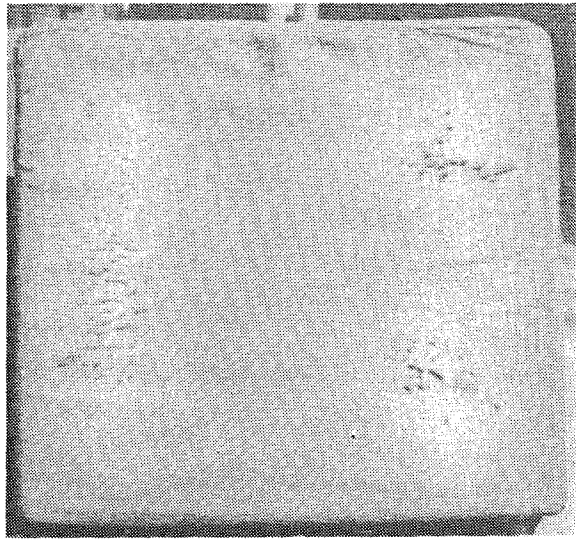

**50 Hours**

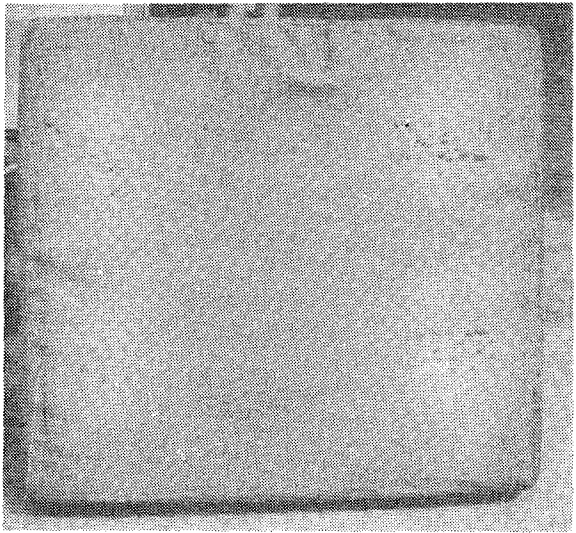
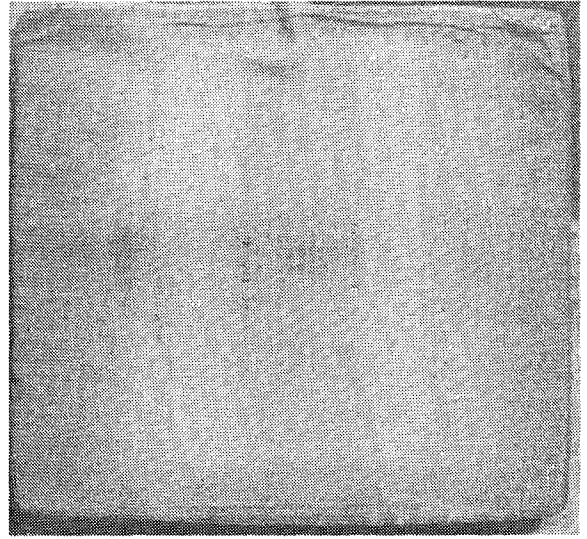

**25 Hours**

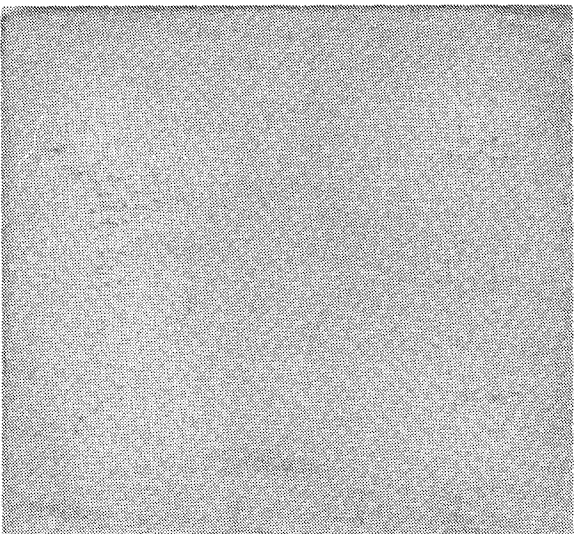
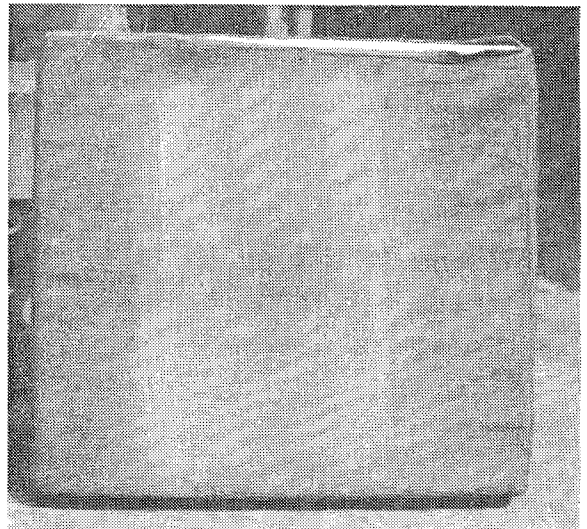

**10 Hours**

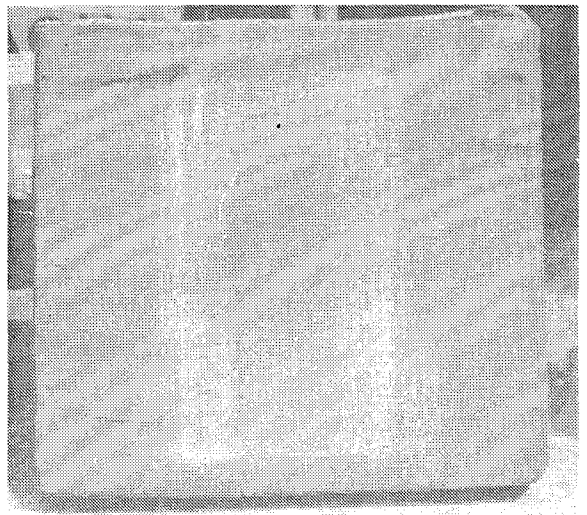

**Top**

**Bottom**

FIGURE 4. TESTORI FBL MATERIAL 2 AFTER EXPOSURE TO THE "SQUIRMING HERMAN" (FROM TRANS WORLD EXPRESS'S ATR-42 SEATS)

**TABLE 4 . FLAMMABILITY TEST RESULTS ON WEAR TESTED SEATS  
(From China Eastern Airline's MD-11 seats) - Test Series 3**

TEST	Wear Exposure	Pretest Weight	Postest Weight	% Weight Loss	Burn Length Measurements			
					Bottom Cushion		Back Cushion	
					Topside	Bottomside	Frontside	Backside
1	10 hrs.	6.08 lbs.	5.40 lbs.	11.2%	10.0 in.	6 in.	13.5 in.	0 in.
2	25 hrs.	6.78 lbs.	6.10 lbs.	10.3%	8.5 in.	10 in.	11.0 in.	0 in.
3	50 hrs.	6.68 lbs.	5.98 lbs.	10.5%	10.5 in.	10 in.	10.0 in.	0 in.

The average percentage weight loss computed to be 10.6 percent which is one reason these specimens failed the oil burner tests. The cushions also failed because two of the three cushions had a weight loss above 10 percent. However, the margin of failure was very small since the pass/fail criterion is 10 percent.

The second series of flammability tests were conducted on wear tested cushions which are presently used on Trans World Express's ATR-42. In this series of tests, the results did have a pattern showing that increased wear caused a depreciation in the FBLs resistance against a fire. This pattern can be viewed in table 5 .

**TABLE 5. FLAMMABILITY TEST RESULTS ON WEAR TESTED SEATS  
(FROM TWE's ATR-42 seats) - Test Series 2A**

TEST	Wear Exposure	Pretest Weight	Postest Weight	%Weight Loss	Burn Length Measurements			
					Bottom Cushion		Back Cushion	
					Topside	Bottomside	Frontside	Backside
1	10 hrs.	6.82 lbs.	5.78 lbs.	15.25 %	12.25 in.	9.0 in.	18.0 in.	1.5 in.
2	25 hrs.	6.80 lbs.	5.50 lbs.	19.12 %	11.50 in.	10.5 in.	17.0 in.	0.0 in.
3	50 hrs.	6.80 lbs.	5.40 lbs.	20.59 %	13.00 in.	17.5 in.	17.5 in.	0.0 in.

## CONCLUSION

1. From the series of flammability tests run on the Testori FBL material used on China Eastern Airline's MD-11, reference no 0200-316, the cushions did not pass the oil burner test criteria. In the first series of tests, the cushions actually onboard Flight 583 failed considerably with a weight loss of 23.9 percent; however, only one set was tested. In the second series of tests run with the cushions fabricated to test regulation size from new materials provided by the manufacturer, the cushions failed because two of the three specimen sets tested exceeded 10 percent (10.07 and 10.21 percent). The cushions that failed the third series of tests were the cushions that were subjected to wear exposure and failed because the average weight loss was 10.6 percent and two of the three cushions had a weight loss above 10 percent (11.2, 10.3, and 10.5 percent). There was no correlation between the length of time of wear exposure and the FBL protective characteristics.
2. The results from the series of flammability tests run on the Testori FBL material used on Trans World Express's ATR-42, reference no. 0206-100, demonstrated that the cushions failed due to an excessive weight loss percentage of 13.6 percent. When the cushions fabricated from the same material were subjected to wear exposure with the Squirring Herman and the flammability test, a pattern developed between length of wear exposure and fire barrier-retardant characteristics - the longer the wear the higher the percentage weight loss. The cushions failed all three oil burner seat cushion criteria:
  - a. The average percentage weight loss was 17.32 percent.
  - b. All three cushions were above 10 percent weight loss (15.25, 19.12, and 20.59 percent).
  - c. Two of the three cushions exceeded a burn length of 17 inches (back cushions, frontside from test 2 - was 18 inches and test 4 - was 17.5 inches).

## REFERENCES

1. "Inadvertent In-Flight Slat Deployment", Aircraft Accident Report NTSB/AAR-93/07 National Transportation Safety Board, Washington, D.C., April 6, 1993.
2. Aircraft Materials Fire Test Handbook DOT/FAA/CT-89/15, U.S. Department of Transportation, Federal Aviation Administration, Atlantic City International Airport, NJ September 1990., Chap. 7, "Oil Burner Test For Seat Cushion", pp. 7-1 to 7-28.
3. Wilson, Ralph L., "Survival Factors Group Chairman's Factual Report of Investigation", National Transportation Safety Board, Washington, D.C., June 18, 1993.
4. Hoyt, Louis, "Serviceability Evaluation of Seat Cushion Fire Blocking Layers". Engineering Report WS 8492, Weber Aircraft, Division of Kidde Burbank, CA, June 4, 1985.

## GLOSSARY

### *Definitions of Flammability Test Terms*

#### **Back Cushion Specimen**

The back cushion specimen is the cushion specimen in the vertical orientation. This specimen may be representative of either the production seat back or seat bottom or both, if the production articles have the same construction.

#### **Bottom Cushion Specimen**

The bottom cushion specimen is the cushion specimen in the horizontal orientation. This specimen may be representative of either the production seat back or bottom or both, if the production articles have the same construction.

#### **Burn Length(s)**

The four principal burn lengths are measured along the topside of the horizontal seat cushion, bottomside of the horizontal seat cushion, frontside of the vertical seat cushion, and the backside of the vertical seat cushion. The four burn lengths are defined as the distance measured, in inches, from the edge of the seat frame nearest the burner to the farthest point where damage to the test specimen due to that area's combustion, including partial or complete consumption, charring, or embrittlement, but does not include areas sooted, stained, warped, or discolored.

#### **Percent Weight Loss**

The percentage weight loss for a specimen set is the pretest weight of the specimen set less the posttest weight of the specimen set expressed as the percentage of the pretest weight. All droppings falling from the specimens and mounting stand are to be discarded prior to determining the posttest weight.

#### **Specimen Set**

A specimen set consists of one back cushion specimen and one bottom cushion specimen. Both specimens represent the same production cushion construction; that is, both specimens in the specimen set have identical construction and materials, proportioned to correspond to the specimen size.