

Report No. CG-D-03-95

## Experimental Determination of the Added Inertia and Damping of Planing Boats in Roll

P. Ward Brown  
and  
Walter E. Klosinski

Davidson Laboratory  
Stevens Institute of Technology  
Castle Point Station  
Hoboken, NJ 07030



FINAL REPORT  
JANUARY 1995



This document is available to the U.S. public through the  
National Technical Information Service, Springfield, Virginia 22161

Prepared for:

U.S. Coast Guard  
Research and Development Center  
1082 Shennecossett Road  
Groton, CT 06340-6096

and

U.S. Department Of Transportation  
United States Coast Guard  
Office of Engineering, Logistics, and Development  
Washington, DC 20593-0001

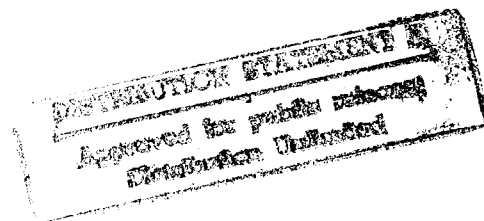

19950309 047

# NOTICE

This document is disseminated under the sponsorship of the Department of Transportation in the interest of information exchange. The United States Government assumes no liability for its contents or use thereof.

The United States Government does not endorse products or manufacturers. Trade or manufacturers' names appear herein solely because they are considered essential to the object of this report.

The contents of this report reflect the views of the Coast Guard Research & Development Center. This report does not constitute a standard, specification, or regulation.

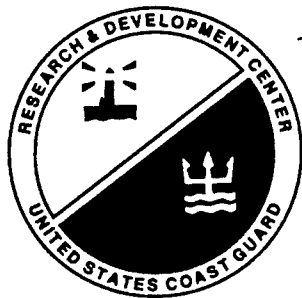

W. E. Colburn, Jr.

Technical Director, Acting  
United States Coast Guard  
Research & Development Center  
1082 Shennecossett Road  
Groton, CT 06340-6096

1. Report No. CG-D-03-95	2. Government Accession No.	3. Recipient's Catalog No.	
4. Title and Subtitle Experimental Determination of the Added Inertia and Damping of Planing Boats in Roll		5. Report Date January 1995	
		6. Performing Organization Code	
7. Author(s) P. Ward Brown and Walter E. Klosinski		8. Performing Organization Report No. R&DC 14/91	
9. Performing Organization Name and Address Davidson Laboratory Stevens Institute of Technology Castle Point Station Hoboken, NJ 07030		10. Work Unit No. (TRAVIS)	
		11. Contract or Grant No. DTCG23-85-C-20060	
		13. Type of Report and Period Covered Final Report	
12. Sponsoring Agency Name and Address U.S. Coast Guard Research and Development Center 1082 Shennecossett Road Groton, Connecticut 06340-6096		14. Sponsoring Agency Code	
		Department of Transportation U.S. Coast Guard Office of Engineering, Logistics, and Development Washington, D.C. 20593-0001	
15. Supplementary Notes Coast Guard R&D Center COTR: James A. White, 203-441-2734.			
16. Abstract <p>This is the third of four reports on research designed to obtain basic hydrodynamic information about planing hulls through the use of captive models tests. The information is to be used for the general study of dynamic stability while underway, course keeping, turning and maneuvering, etc. The models tested were of idealized patrol boats having an LBP of 100 ft., a beam of 20 ft., and a displacement of 100 long tons. The models had prismatic hull forms with 10, 20, and 30 degrees of deadrise.</p> <p>The report presents the results of free oscillation tests on two unappended prismatic hulls of 10 and 20 degrees of deadrise. The tests were conducted at a beam loading coefficient of 0.4375, at three speeds [<math>C_v = 1.5, 3.0, \text{ and } 4.0</math>], three trim angles [0, 3, and 6 degrees], and at yaw angles of 0, 10, and 15 degrees. Roll extinction records were taken with three different spring stiffnesses, first at rest in air and then underway in water, at each test condition. The roll period and logarithmic decrement were determined from these records and tabulated. The added mass moment of inertia and damping in roll were deduced from these data assuming a linear damped harmonic oscillator. Empirical expressions for the inertia and damping are presented and compared with the data. These expressions are used to predict the rolling characteristics of a prototype 100 ft. boat.</p>			
17. Key Words Planing boats Roll stability Roll oscillation Roll inertia Roll damping		18. Distribution Statement Document is available to the U.S. public through the National Technical Information Service, Springfield, Virginia 22161	
19. Security Classif. (of this report) UNCLASSIFIED	20. SECURITY CLASSIF. (of report) UNCLASSIFIED	21. No. of Pages PLEASE CROSS-REFERENCE THIS REPORT WITH REPORT NO. CG-D-04-95	22. Price "EXPERIMENTAL DETERMINATION OF THE ADDED INERTIA AND DAMPING OF A 30 DEGREE DEADRISE PLANING BOAT IN ROLL"

# METRIC CONVERSION FACTORS

## Approximate Conversions to Metric Measures

Symbol When You Know Multiply By To Find Symbol

### LENGTH

in	inches	* 2.5	centimeters	cm
ft	feet	30	centimeters	cm
yd	yards	0.9	meters	m
mi	miles	1.6	kilometers	km

### AREA

in <sup>2</sup>	square inches	6.5	square centimeters	cm <sup>2</sup>
ft <sup>2</sup>	square feet	0.09	square meters	m <sup>2</sup>
yd <sup>2</sup>	square yards	0.8	square meters	m <sup>2</sup>
mi <sup>2</sup>	square miles	2.6	square kilometers	km <sup>2</sup>
	acres	0.4	hectares	ha

### MASS (WEIGHT)

oz	ounces	28	grams	g
lb	pounds	0.45	kilograms	kg
	short tons (2000 lb)	0.9	tonnes	t

### VOLUME

tsp	teaspoons	5	milliliters	ml
tbsp	tablespoons	15	milliliters	ml
fl oz	fluid ounces	30	milliliters	ml
c	cups	0.24	liters	l
pt	pints	0.47	liters	l
qt	quarts	0.95	liters	l
gal	gallons	3.8	liters	l
ft <sup>3</sup>	cubic feet	0.03	cubic meters	m <sup>3</sup>
yd <sup>3</sup>	cubic yards	0.76	cubic meters	m <sup>3</sup>

### TEMPERATURE (EXACT)

°F	Fahrenheit temperature	5/9 (after subtracting 32)	Celsius temperature	°C
----	------------------------	----------------------------	---------------------	----

\*1 in = 2.54 (exactly).

## Approximate Conversions from Metric Measures

Symbol When You Know Multiply By To Find Symbol

### LENGTH

mm	millimeters	0.04	inches	in
cm	centimeters	0.4	inches	in
m	meters	3.3	feet	ft
m	meters	1.1	yards	yd
km	kilometers	0.6	miles	mi

### AREA

cm <sup>2</sup>	square centimeters	0.16	square inches	in <sup>2</sup>
m <sup>2</sup>	square meters	1.2	square yards	yd <sup>2</sup>
km <sup>2</sup>	square kilometers	0.4	square miles	mi <sup>2</sup>
ha	hectares (10,000 m <sup>2</sup> )	2.5	acres	

### MASS (WEIGHT)

g	grams	0.035	ounces	oz
kg	kilograms	2.2	pounds	lb
t	tonnes (1000 kg)	1.1	short tons	

### VOLUME

ml	milliliters	0.03	fluid ounces	fl oz
l	liters	0.125	cups	c
l	liters	2.1	pints	pt
l	liters	1.06	quarts	qt
l	liters	0.26	gallons	gal
m <sup>3</sup>	cubic meters	35	cubic feet	ft <sup>3</sup>
m <sup>3</sup>	cubic meters	1.3	cubic yards	yd <sup>3</sup>

### TEMPERATURE (EXACT)

°C	Celsius temperature	9/5 (then add 32)	Fahrenheit temperature	°F
----	---------------------	-------------------	------------------------	----

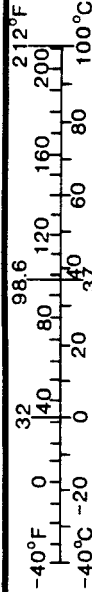

## SPONSORS PREFACE

The Davidson Laboratory was tasked with conducting a series of passive roll oscillation tests in order to determine the hydrodynamic added mass moment of inertia in roll, and the roll damping moment, in support of roll stability studies. The model was to be free to heave and roll, but fixed in trim and yaw. The model was to be perturbed in roll and the resulting oscillations measured as a function of time using a spring loaded, passive oscillator. This was to be done at rest in air and at planing speeds in water. A second order linear model was assumed and the added moment of inertia, and damping moment, deduced from the decaying oscillatory time history. This approach was designed to provide needed data at an economical cost.

The Davidson Laboratory did an excellent job in carrying out this task. In fact the laboratory exceeded expectations in developing empirical expressions for the added mass moment of inertia and damping. It should be emphasized that these are empirical expressions that are dimensionally correct, but are without a foundation in theoretical hydrodynamics. In addition, the equations apply to the roll axis used in the experiments described in the report. Caution should therefore be exercised in applying the equations to full scale planing hulls.

The following statements are made in the DISCUSSION section of the report. First, "Unlike displacement craft, the support of a planing boat comes principally from dynamic pressure and is therefore largely independent of gravity effects. For this reason it is to be expected that the hydrodynamic added inertia of a rolling planing boat will be independent of frequency. Therefore the hydrodynamic inertia should not be affected by mechanical spring stiffness. This expectation is born out by the results." Second, "Similarly, since the hydrodynamic damping should be independent of the mechanical spring stiffness, the damping results have been collected in Table 5 and averaged."

The Project Officer for the sponsoring agency does not endorse the view that the added mass moment of inertia and the damping moment on a planing hull is independent of frequency. Approximately one third of the data was taken at a trim angle of zero degrees. Far from being supported by dynamic pressure, the model experienced considerable sinkage due to negative dynamic pressure. It is true that no consistent dependence of added mass moment of inertia or damping could be deduced from the data. This is attributed in part to scatter in the data. There are reasons to believe that an oscillating planing hull will radiate waves. This would lead to frequency dependent added mass moments of inertia and damping moments. Improvements in experimental technique, the modeling of the decaying oscillation, and data analysis are required before any definitive statement can be made on the subject of frequency dependence.

Availability Codes	
Dist	Avail and/or Special
A-1	

## TABLE OF CONTENTS

NOMENCLATURE . . . . .	viii
INTRODUCTION . . . . .	1
MODELS . . . . .	1
APPARATUS AND INSTRUMENTATION . . . . .	2
TEST PROCEDURE AND TEST PROGRAM . . . . .	4
DATA PROCESSING . . . . .	6
RESULTS . . . . .	8
ANALYSIS . . . . .	8
DISCUSSION . . . . .	10
APPLICATION TO FULL SIZE BOAT . . . . .	11
CONCLUDING REMARKS . . . . .	13
RECOMMENDATIONS . . . . .	14
REFERENCES . . . . .	15

## TABLES

TABLE 1	TABLE OF PARTICULARS . . . . .	16
TABLE 2	ROLL EXTINCTION RESULTS - 10 DEGREE DEADRISE . . . . .	17
TABLE 3	ROLL EXTINCTION RESULTS - 20 DEGREE DEADRISE . . . . .	20
TABLE 4	ADDED INERTIA . . . . .	23
TABLE 5	ROLL DAMPING . . . . .	25

## FIGURES

FIGURE 1	LINES OF 20° DEADRISE PARENT MODEL . . . . .	27
FIGURE 2	LINES OF 10° DEADRISE MODEL . . . . .	28
FIGURE 3	MODEL IN ROLL APPARATUS PRIOR TO RELEASE . . . . .	29
FIGURE 4A	SIDE VIEW OF ROLL OSCILLATION APPARATUS . . . . .	30
FIGURE 4B	END VIEW OF ROLL OSCILLATION APPARATUS . . . . .	31
FIGURE 5	INSTALLATION OF ROLL APPARATUS IN MODEL . . . . .	32
FIGURE 6	VARIATION OF ROLL STIFFNESS WITH SPEED AT ZERO YAW . . . . .	33
FIGURE 7	COMPARISON OF OBSERVED AND PREDICTED PERIODS . . . . .	34
FIGURE 8	COMPARISON OF OBSERVED AND PREDICTED DECREMENTS . . . . .	35

## NOMENCLATURE

b	beam at chine, ft
CG	center of gravity
$C_{\Delta}$	beam loading coefficient, $\Delta/wb^3$
$C_v$	velocity coefficient, $V/\sqrt{gb}$
c	roll damping, lb-ft/radians per second
g	acceleration due to gravity, 32.17 fps <sup>2</sup>
I	roll moment of inertia, slug-ft <sup>2</sup>
k	roll stiffness, lb-ft/radian
T	roll period, seconds
t	time, seconds
V	velocity, fps
w	specific weight of water, 62.28 lb/cu.ft fresh water at 71.5°F
$\beta$	deadrise angle, degrees
$\Delta$	displacement, lb
$\delta$	roll decrement
$\phi$	roll angle, radians
$\phi^*$	magnitude of maximum and minimum roll angle excursions, radians
$\psi$	yaw angle, degrees
$\rho$	density of water, w/g, 1.9359 slugs/cu.ft at 71.5°F

## Subscripts

h	hydrodynamic
m	mechanical

## INTRODUCTION

The Davidson Laboratory is conducting a series of planing boat studies in support of the U.S. Coast Guard's pursuit of R&D projects that will enable it to evaluate advanced marine vehicles and advanced technologies which enhance the effectiveness of ship resources. The experimental results obtained at the Davidson Laboratory are intended to contribute to a relevant technical data base for the evaluation of vessels that are in service and for designs that are being considered for service.

The objective of this research is to obtain basic hydrodynamic information about planing hulls by captive model tests. This information is required for the study of the transverse stability, yaw/roll stability, course keeping, maneuvering and control of planing hulls, and for the study of seakeeping, and the loss of speed in a seaway of planing hulls.

The research results presented in this report are concerned with the hydrodynamic added mass moment of inertia in roll, and the roll damping moments of two prismatic planing hulls having deadrise angles of 10 and 20 degrees, both of length-beam ratio 5. The results of roll oscillation tests with these hulls operating on straight course are reported. The unappended models were tested over ranges of trim and yaw, at three speeds, and one displacement.

Measured quantities included digitized time histories of the roll extinction, from which the frequency and logarithmic decrement of the roll motion were determined. Video recordings were made of all runs.

The data are presented in tabular form. The added roll moment of inertia and the hydrodynamic roll damping are determined from an analysis of this data.

## MODELS

The model series was designed at the Davidson Laboratory and approved by the Coast Guard. It is intended to provide for variations in deadrise and bow form. The parent of the model series is a 20 degree deadrise prismatic hull with flat sections and a length-beam ratio of 5. The parent model is shown on Figure 1 and is a 1/26.66-scale model representing a boat with a design waterline length of 100 feet displacing 100 long tons. The 10 degree

deadrise hull developed from the parent is also a 1/26.66-scale model and is shown on Figure 2. Hull characteristics are given in Table 1.

The forebody of the parent hull is fair and represents bow shapes that may be expected to be found on patrol boats in service at this time. The after 50% of the hull is a pure prismatic form of constant deadrise with vertical sides. The intersection of the forebody with the prismatic afterbody is smooth and fair, without abrupt changes in curvature at the transition. The transom is a plane surface normal to the keel.

The model was built of sugar pine with 3/8 inch wall thickness, glued with a powdered resin, water-resistant glue. Templates were made from the lines drawing and used during model construction. They were fitted to the model so that no light showed between the template and the model. The finish of the model included the application of one coat of Watco penetrating waterproof sealer, and five coats of Lenmar varnish with catalyzed hardener rubbed down between coats: the first coat being dry-sanded and all subsequent coats wet-sanded. The bottom of the model was given two white spray coats and finally the entire model was wet-sanded.

Spray rails were fitted at the model chines running forward from Station 5 to the stem. To ensure clean separation of the water from the chine, spray strips were fitted at the chines from Station 5 to the transom. These strips consisted of brass shim stock extending vertically downward from the model chine by 1/32 of an inch.

The model deck was covered and sealed with clear lucite. An opening was left between Stations 3 to 8 to allow for attachment to the roll oscillation apparatus, and to allow access for setting the trim angle. The 10 degree deadrise model undergoing tests is shown in the photograph on Figure 3.

#### APPARATUS AND INSTRUMENTATION

A special roll oscillation apparatus was designed and built by the Davidson Laboratory for these tests. Sketches of this apparatus are included in Figures 4A and 4B. This is a spring loaded device with provision for locking the model at a finite roll angle. When the model is up to speed, the roll lock is released by remote command, and the resulting damped roll angle oscillation is recorded by a rotary transducer on the roll axis. The

mechanical roll stiffness can be varied by changing the coil springs; three different sets of springs were used. Provision for setting the trim and yaw of the model is included.

This "free-oscillation" mechanism is used to determine the roll moment of inertia and damping of the model, both in air and in water. The stiffness of the mechanical springs is measured, and the model oscillated while at rest in the air. A time history recording is made of the damped roll angle oscillation. The rigid body mass moment of inertia in roll is determined from the observed period of the oscillation, and the known spring stiffness. The roll damping is determined from the logarithmic decrement of the roll decay time history. (The procedure is described in the DATA PROCESSING section). The roll damping in air is found to be small, being due mostly to mechanical friction in the "free-oscillation" mechanism.

This experiment is repeated at speed in the water. The model is locked at a roll angle of 10 degrees, and released when the model is up to speed. The resulting time history of the damped oscillation is recorded from which the period and logarithmic decrement of the oscillation may be determined. In the case of the model in the water, the mechanical stiffness is augmented by the hydrodynamic roll stiffness, which must be determined by an auxiliary experiment, i.e. from Reference 1. The virtual roll moment of inertia (rigid body plus hydrodynamic) is found from the period and total stiffness, (as described in the ANALYSIS section). The added hydrodynamic roll moment of inertia is found by subtracting the rigid body roll moment of inertia (determined in air) from the virtual roll moment of inertia of the model in water. Similarly, the damping is deduced from the logarithmic decrement, and the hydrodynamic damping is found by subtracting the mechanical damping. In these tests the mechanical damping was negligible.

The roll oscillation apparatus, with provision for setting the trim and yaw angles, was mounted in the model, as shown on Figure 5. For these tests the model was free to heave but fixed in trim, and yaw. The intersection of the pitch and roll axes defines the tow point. This point was located 22.5 inches forward of the transom and 2.75 inches above the keel. Throughout this report, quantities will be given either in model scale or in units of beam. Since the beam of the models is 9 inches, the co-ordinates of the tow point are 2.5 beams forward of the transom and 0.306 beams above the keel. The roll oscillation apparatus was attached to twin vertical heave poles in a standard

free-to-heave apparatus. This apparatus includes provision for counter-weighting. The counter-weighting is used to maintain the ballasted displacement of the model, (or "load-on-water" in the case of planing craft). The free-to-heave apparatus was mounted on a standard testing carriage that was run on the Tank 3 rail. A video camera was mounted above, forward and to port of the model, and a video recording was made of each run.

The roll extinction tests were carried out in the Davidson Laboratory Tank 3 (313 ft long by 12 ft wide by 6 ft deep). A photograph of the 10 degree deadrise model being tested is included on Figure 3, which shows the model before release of the roll lock.

#### TEST PROCEDURE AND TEST PROGRAM

A series of preliminary runs were made with the model in water, in order to select the stiffness of the coil springs. The 20 degree deadrise model was setup in the apparatus at a model displacement of 11.49 lb, corresponding to a beam loading of 0.4375, and fixed at 3 degrees trim. Analysis of the roll decay requires a number of cycles, so that the frequency and decrement can be determined with some degree of precision. It was found that the planing hull was quite well damped in roll, becoming heavily damped at high speed. Therefore it was necessary to select very stiff mechanical springs so that the model would perform sufficient oscillations to permit analysis. Based on an analysis of the data presented in Reference 1, the natural hydrodynamic stiffness of the model was estimated to be 3.0 lb-ft per radian. The mechanical springs chosen for these tests were from 7 to 21 times as stiff.

Calibrations were performed with the model in the air. The roll transducer was calibrated in-place, and its output fed to the on-line computer. The calibration was linear and a least-squares regression analysis was performed to determine the rate. The coil springs were removed and the ballast of the model adjusted to bring the VCG onto the roll axis. Then each pair of springs was installed in turn and calibrated for stiffness. Roll moments were applied to the mechanism, the roll angular deflection determined and the roll stiffness calculated.

Oscillation experiments were carried out with the models in the air using three sets of springs, to determine the roll inertia of each model. The carriage was moved out of the dock, and positioned under one of the rail

support stanchions to provide the most rigid support for the carriage. The roll was locked at 10 degrees, then the model was released and allowed to perform free roll oscillations. The resulting time history was analyzed using 25 oscillations. The mechanical damping was negligible, with a logarithmic decrement of 0.05. The values of stiffness and roll moment of inertia for the 10 and 20 degree deadrise models on the oscillation apparatus were:

Spring Number	Stiffness lb-ft per radian	Moment of inertia, slug-ft.sq	
		Deadrise 10°	Deadrise 20°
S2	22.9	0.0429	0.0389
S4	38.3	0.0420	0.0390
S1	63.3	0.0425	0.0389

At the model displacement of 11.49 lb, the roll moments of inertia for the two models were taken to be 0.0425 slug-ft.sq for the 10 degree deadrise model, and 0.0389 slug-ft.sq for the 20 degree deadrise model.

The following procedure was used to conduct hydrodynamic roll extinction tests of the two models at speed, at a beam loading of 0.4375. The initial tension in the port and starboard springs was adjusted so that the roll angle of the model was close to zero, and the "zero" roll angle was recorded. The model was locked at a roll angle of 10 degrees by a solenoid operated pin, and the required trim and yaw angles were set. The model was then accelerated up to speed, and data were acquired in the 100 ft data trap. Ten feet into the data trap the roll lock was released, and the resulting roll oscillation recorded. The roll channel was scanned at 250 Hz, and the time history stored in the on-line computer.

The following matrix of conditions was used for the tests of the unappended 10 and 20 degree deadrise hulls:

Beam loading	0.4375
Speed, Cv	0, 1.5, 3, 4
Trim, degrees	0, 3, 6
Yaw, degrees	0, 10, 15
Spring stiffness, lb-ft per radian	22.9, 38.3, 63.3

Video recordings were made of each run, and a selection of color still photographs were taken.

#### DATA PROCESSING

The data yielded by the tests consisted of time histories of the roll oscillations of the model digitized at a scan rate of 250 Hz. The equation of motion is assumed to be that of a damped harmonic oscillator of the form:

$$I\ddot{\phi} + c\dot{\phi} + k\phi = 0 \quad (1)$$

whose solution, apart from a multiplicative constant, is of the form:

$$\phi = \exp(-\delta t/T) \cos(2\pi t/T) \quad (2)$$

$$\text{where logarithmic decrement, } \delta = Tc/2I \quad (3)$$

$$\text{and period, } T = 2\pi/\sqrt{[k/I - (c/2I)^2]} \quad (4)$$

From Equations 3 and 4:

$$c = 2I\delta/T \quad (5)$$

$$k = I(4\pi^2 + \delta^2)/T^2 \quad (6)$$

which express the unknown coefficients in terms of the logarithmic decrement and period of the oscillation.

A typical roll time history is shown in Sketch A, below. Maximum and minimum values of roll displacement occur when:

$$t = N/2, \quad \text{where } N = 1, 2, 3, \dots \quad (7)$$

An expression for these maximum and minimum magnitudes may be found by substituting the values of  $t$  from Equation 7 in Equation 2. The magnitudes are denoted by  $\phi^*$ .

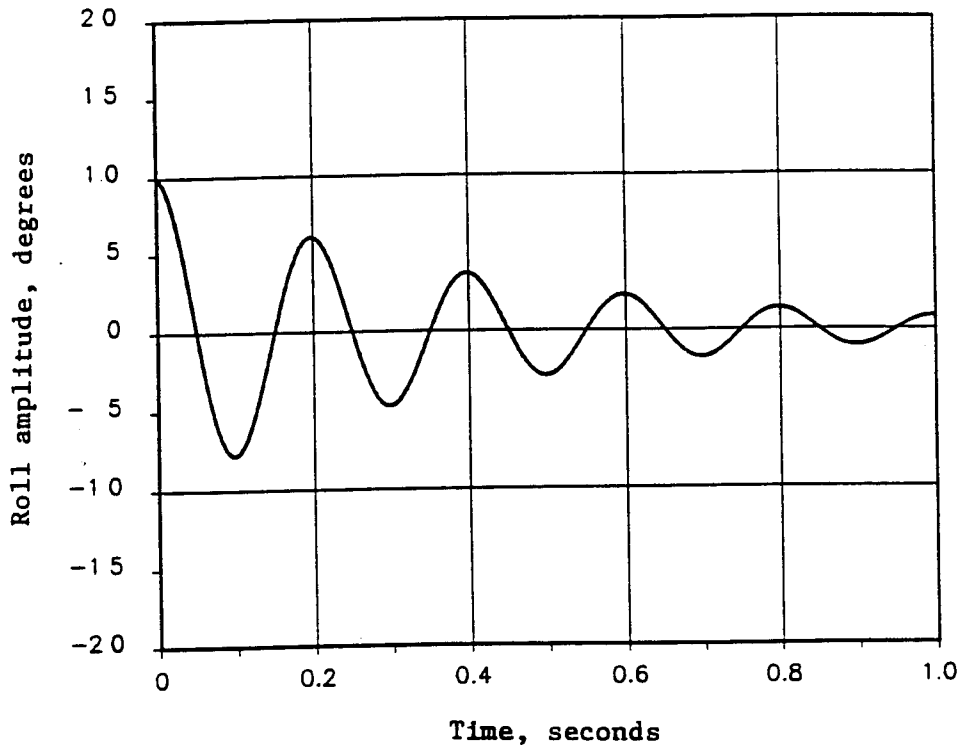

SKETCH A

Substituting for  $t$  from Equation 7 in Equation 2 yields:

$$\phi^* = \exp(-N\delta/2) \cos(N\pi)$$

$$= \pm \exp(-N\delta/2)$$

therefore  $\ln |\phi^*| = -N\delta/2$  (8)

Thus a linear regression of  $\ln |\phi^*|$  on  $N$  yields the logarithmic decrement  $\delta$ . The period is found from the number of oscillations and the elapsed time.

The magnitudes of the maxima and minima were obtained from the digitized time histories by the standard Davidson Laboratory "Peak-Trough" program. Their values together with their scan numbers were written into a separate file known as the "P-File". Programs were written to examine the P-File for consistency. For example, roll magnitudes less than 0.25 degrees were not used. The number of scans between each crest and trough was computed and displayed, giving the operator the option of which cycles to

analyze. If this number varied by more than 6 scans (0.024 seconds) the event was flagged. Some of the maxima were contaminated by mechanical noise from the spring mechanism, and programs were written to flag these occurrences also. In setting up the analysis it had been assumed that the roll would decay to zero degrees, but this was not always the case - particularly at finite yaw angle. Since the existence of this finite offset defeated the analysis, provision was made for offsetting the roll angle zero. On the first pass through the analysis program an estimate of the offset was computed. In subsequent passes the operator could adjust both this offset and the period. A measure of the goodness of fit (rms deviation) was computed to assist in the analysis.

## RESULTS

The results of the roll extinction tests are presented in Tables 2 and 3 for the 10 degree and 20 degree deadrise hulls respectively. For each of the three values of mechanical spring stiffness the following values are tabulated: the run number, the trim and yaw angle, the speed, the number of cycles analyzed, the roll period, and the logarithmic decrement. The derived values of the added roll moment of inertia, and the roll damping are also listed in these tables.

## ANALYSIS

The analysis of the data to determine the inertia and damping is carried out in model scale. The virtual roll moment of inertia (rigid body plus hydrodynamic) and the roll damping are found from Equations 5 and 6. It is assumed that the total stiffness of the oscillating system is the sum of the mechanical (rigid body) and hydrodynamic stiffnesses, and similarly that the roll inertia is the sum of the rigid body and hydrodynamic inertias.

Therefore:

$$k = k_m + k_h \quad (9)$$

$$I = I_m + I_h \quad (10)$$

From Equation 6:

$$I = kT^2/(4\pi^2 + \delta^2)$$

therefore

$$I_m + I_h = (k_m + k_h)T^2/(4\pi^2 + \delta^2)$$

hence

$$I_h = (k_m + k_h)T^2/(4\pi^2 + \delta^2) - I_m \quad (11)$$

The hydrodynamic stiffness,  $k_h$ , was found from Reference 1. The straight course roll moment data given in body axes at the pivot were used, after translation to a point 2.75 inches above the keel. The roll moment was plotted against the roll angle, and the roll stiffness estimated from these plots with the following results:

#### Hydrodynamic Roll Stiffness

Trim deg	Cv	Stiffness, lb-ft per radian	
		Deadrise 10°	Deadrise 20°
0	1.5	3.96	3.74
	3.0	3.68	3.08
	4.0	1.96	1.25
3	1.5	4.13	4.09
	3.0	4.36	4.05
	4.0	4.08	3.73
6	1.5	2.12	3.11
	3.0	1.76	2.93
	4.0	2.50	4.36

The roll stiffness is shown plotted on Figure 6. An average value of 2.7 lb-ft per radian was taken to apply to all conditions. The major contribution to the total stiffness of the oscillatory system comes from the strong mechanical springs in the system. Therefore, the use of an average value for the hydrodynamic stiffness seems reasonable, since a 30% change in hydrodynamic stiffness only affects the calculated roll inertia by 5%. For the same reason, the assumption that the steady-state roll stiffness applies to dynamic roll oscillations is probably acceptable.

All quantities on the right hand side of Equation 11 are now known, so that the added hydrodynamic roll moment of inertia can be determined. This procedure was used to obtain the inertia values in the tables of results.

The damping is found by eliminating  $I$  between Equations 5 and 6 to give:

$$c = 2\delta Tk / (4\pi^2 + \delta^2) \quad (12)$$

and  $k$  is obtained from Equation 9. The damping was not corrected for the for the small contribution from the mechanical damping in the system. Equation 12 was used to calculate the values of roll damping in the tables.

#### DISCUSSION

Unlike displacement craft, the support of a planing boat comes principally from dynamic pressure and is therefore largely independent of gravity effects. For this reason it is to be expected that the hydrodynamic added inertia of a rolling planing boat will be independent of frequency. Therefore the hydrodynamic inertia should not be affected by mechanical spring stiffness. This expectation is borne out by the results. Accordingly the inertia results with the four springs have been collected in Table 4 and averaged across the springs. The hydrodynamic inertia was plotted against the mean wetted lengths given in Reference 1, and reproduced in Table 4. The following expression was deduced for the hydrodynamic roll inertia:

$$I_h = 0.010237 \rho b^5 (\ell_m/b) (1 - \sin\beta), \text{ slug-ft.sq} \quad (13)$$

The values given by this expression are included in Table 4 in the column headed "Formula". This is an empirical expression which is dimensionally correct, and fits the results within 20%. The added inertia appears to vary linearly with wetted length, but to be otherwise independent of speed, trim, and yaw angle.

Similarly, since the hydrodynamic damping should be independent of the mechanical spring stiffness, the damping results have been collected in Table 5 and averaged. An empirical expression for the damping was obtained:

$$c = wb^4\sqrt{(b/g)} (1 - \sin\beta)[0.134 \sin|\psi| + 0.0290 C_v + 0.0199 \ell_m/b], \text{ lb-ft/rps} \quad (14)$$

The values from this equation are included in Table 5 under "Formula", and agree with the measurements within about 20%. The damping increases with yaw angle, speed, and wetted length, but is otherwise independent of trim.

The variability in the data does not permit more precise formulations for the added inertia and damping characteristics. Repeated experiments with either the same or different springs often resulted in a 20% change in results.

The calculated results are compared with the observations on Figures 7 and 8 as an overall check on the empirical equations. Since the original observations consisted of the roll period and logarithmic decrement, these quantities were calculated from Equations 13 and 14 for comparison with the data. It may be noted that at very short wetted lengths (associated high speed and high trim) the experimental added inertias were often negative. This fact is not reflected in Equation 13. Nonetheless, it is considered that the periods shown on Figure 7 are quite well predicted.

On the other hand the prediction of the logarithmic decrements on Figure 8 leaves something to be desired: this scatter might be the result of having only a few oscillations to analyze.

#### APPLICATION TO FULL SIZE BOAT

All the results and discussion have been presented in terms of the model, and are somewhat obscured by the experimental technique. In particular the use of auxiliary springs to prolong the oscillations, thereby changing the

apparent damping, may distort the appreciation of the results. To remedy this situation the dynamic roll behavior of the prototype 100 ft, 100 ton planing boat is predicted, and its damping expressed in terms of the critical damping.

The particulars of the prototype boat are given in the following table:

TABLE A

Displacement, lb	224,000
Deadrise, degrees	20
Beam, ft	20
LCG, forward of transom, ft	42
VCG, above baseline, ft	6.7
Roll stiffness, lb-ft/radian	1,560,000
Roll radius of gyration, ft	8
Roll moment of inertia, slug-ft.sq	445,600

The roll characteristics are estimated for speeds of 22.5, 45 and 60 knots, at which the mean wetted lengths are estimated to be 84.7 ft, 66.4 ft and 55.6 ft respectively, for the 42 ft LCG.

The amount of damping in a system is often expressed in terms of the critical damping. When the system is lightly damped the motion is periodic, and becomes aperiodic when it is heavily damped. Critical damping forms the demarcation point between oscillatory and non-oscillatory motion. The equation for the critical damping is:

$$c = \sqrt{4Ik} \quad (15)$$

The ratio of the damping to the critical damping is known as the damping factor. This and other quantities are calculated from Equations 13, 14, and 15 for zero yaw, and are presented in the following table:

TABLE B

Speed knots	Cv	Wetted Length beams	Added Inertia slug-ft.sq	Total Inertia	Critical Damping lb-ft/rps	Hydro Damping	Damping Factor	Roll Period seconds
22.5	1.5	4.23	181,500	627,100	1,978,100	678,800	0.343	4.24
45.0	3.0	3.32	142,400	588,000	1,915,600	814,000	0.425	4.26
60.0	4.0	2.78	119,300	564,900	1,877,400	1,041,300	0.555	4.54

This planing boat design is quite well damped, particularly at high speed. Recovering from a roll excursion at 60 knots, the amplitude of the first overshoot would amount to only 10 percent of the disturbance. With the aid of the equations for added inertia and damping, the designer can predict the roll response of his planing craft.

#### CONCLUDING REMARKS

A new apparatus was designed and constructed for making roll oscillation tests of planing boat models while underway. The results of free oscillation tests with two prismatic planing hulls of 10 and 20 degrees deadrise using this apparatus are presented. The tests were made at one displacement and covered variations in speed, trim, and yaw. The hydrodynamic effects of added inertia and damping in roll are deduced, and expressions for these quantities are obtained in terms of the craft's geometry and operating conditions. The correlation between the formulae and the data is presented. The equations are used to predict the response of a 100 ft planing craft at speeds up to 60 knots.

The expressions for the hydrodynamic roll inertia and roll damping are:

$$I_h = 0.010237 \rho b^5 (\ell_m/b) (1 - \sin\beta), \text{ slug-ft.sq}$$

$$c = wb^4 \sqrt{(b/g)} (1 - \sin\beta) [0.134 \sin|\psi| + 0.0290 C_v + 0.0199 \ell_m/b], \text{ lb-ft/rps}$$

These empirical equations are based on limited data, and have the following ranges of applicability:

Parameter	Range
$C_{\Delta}$	0.4375
$l_m/b$	1 to 5
$C_v$	1.5 to 4.0
Deadrise, degrees	10 to 20
Trim, degrees	0 to 6
Yaw, degrees	-15 to +15

Although the data were obtained at one displacement, it is hoped that the inclusion of the mean wetted length-beam ratio in the expressions will alleviate this restriction.

#### RECOMMENDATIONS

Some lessons were learned in working with the new roll oscillation apparatus that should be recorded for future use. The first of these concerns the roll angle zero. With the model setup in the roll apparatus, but free to roll, tests should be run at each value of trim, yaw and speed to determine the steady state roll angle. This steady state value should be used as the appropriate zero roll angle for each of the test conditions. Underwater pictures should be taken to determine the wetted lengths while these steady state tests are being conducted. Since the hydrodynamic stiffness must be known in order to analyze the results, steady state tests should be run at several applied roll moments and the roll angles measured. At present, the apparatus does not work as smoothly as would be desirable, partly due to the initial release of the roll lock, and partly due to interferences in the spring mechanism just at the point where the roll velocity changes direction. Both these defects inject noise into the roll angle signal. Consideration might be given to replacing the coil springs with a longitudinal torsion bar.

From the hydrodynamic point of view, in future tests it would be desirable to determine the effect on the roll inertia and damping of changing the displacement.

REFERENCES

1. Brown, P. Ward, and Klosinski, Walter E.: Directional Stability Tests  
of Two Prismatic Planing Hulls  
Davidson Laboratory Report 2614, March 1990  
USCG R&D Report No. CG-D-11-94, June 1994  
Government Accession No. AD-A 282782.

TABLE 1

## TABLE OF PARTICULARS

	Model	Full Size
Scale	1/26.66	1/1
Displacement	11.49 lb	100 long tons
Load coefficient	0.4375	0.4375
Beam	9 in	20 ft
Lengths		
Overall, LOA	50 in	110 ft
Projected chine LP	47.5 in	105 ft
Design, DWL or LBP	45 in	100 ft
Length-beam ratios		
Overall	5.50	5.50
Projected Chine	5.25	5.25
Between perpendiculars	5.00	5.00
Tow point		
Forward of transom	22.5 in	
Above keel	2.75 in	

TABLE 2.1

## ROLL EXTINCTION RESULTS - 10 DEGREE DEADRISE

SPRING STIFFNESS 22.9 lb-ft per radian

Run	Trim deg	Yaw deg	Cv	No. of Cycles	Roll Period seconds	Logarithmic Decrement	Added Inertia slug-ft.sq	Damping lb-ft/rps*
263	0	0	1.5	7	0.293	0.5118	0.0135	0.1955
264	0	0	3.0	6	0.309	0.5555	0.0197	0.2235
265	0	0	4.0	4	0.322	0.7708	0.0245	0.3208
242	3	0	1.5	6	0.294	0.5268	0.0138	0.2018
243	3	0	3.0	4	0.299	0.9325	0.0149	0.3580
244	3	0	4.0	3	0.298	1.1653	0.0138	0.4405
245	3	0	4.0	3	0.290	1.2210	0.0107	0.4477
274	6	0	1.5	6	0.292	0.5698	0.0130	0.2165
275	6	0	3.0	3	0.282	1.0873	0.0082	0.3906
276	6	0	4.0	3	0.255	1.0761	-0.0011	0.3498
266	0	10	1.5	5	0.307	0.7003	0.0186	0.2786
246	3	10	1.5	4	0.306	0.8221	0.0179	0.3245
247	3	10	3.0	3	0.290	1.3141	0.0104	0.4791
248	3	10	4.0	2	0.302	1.3507	0.0147	0.5116
277	6	10	1.5	5	0.295	0.7293	0.0138	0.2785
278	6	10	3.0	4	0.273	0.8782	0.0055	0.3085
279	6	10	4.0	3	0.249	1.0574	-0.0029	0.3360
280	6	10	4.0	3	0.240	0.9978	-0.0056	0.3065
269	0	15	1.5	3	0.312	1.0503	0.0196	0.4183
249	3	15	1.5	3	0.321	0.9778	0.0235	0.4021
250	3	15	3.0	2	0.293	1.3580	0.0113	0.4988
251	3	15	3.0	2	0.305	1.3709	0.0158	0.5237
252	3	15	4.0	2	0.285	1.6175	0.0075	0.5673
281	6	15	1.5	3	0.304	0.9639	0.0167	0.3756
282	6	15	3.0	4	0.272	1.0071	0.0048	0.3504
283	6	15	3.0	3	0.276	0.9518	0.0064	0.3370
284	6	15	4.0	3	0.238	0.8952	-0.0061	0.2740
285	6	15	4.0	3	0.241	0.9180	-0.0052	0.2842

\* rps = radians per second

TABLE 2.2

## ROLL EXTINCTION RESULTS - 10 DEGREES DEADRISE

SPRING STIFFNESS 38.3 lb-ft per radian

Run	Trim deg	Yaw deg	Cv	No. of Cycles	Roll Period seconds	Logarithmic Decrement	Added Inertia slug-ft.sq	Damping lb-ft/rps*
195	0	0	1.5	8	0.233	0.4458	0.0140	0.2162
196	0	0	3.0	6	0.247	0.5241	0.0209	0.2690
197	0	0	4.0	5	0.207	0.8648	0.0015	0.3676
211	3	0	1.5	8	0.234	0.4558	0.0145	0.2220
212	3	0	3.0	4	0.233	0.8270	0.0133	0.3963
213	3	0	4.0	3	0.225	0.9780	0.0092	0.4495
180	6	0	1.5	8	0.229	0.4427	0.0121	0.2111
181	6	0	3.0	4	0.216	0.7950	0.0055	0.3536
182	6	0	4.0	5	0.200	0.7236	-0.0012	0.2988
198	0	10	1.5	5	0.239	0.6480	0.0166	0.3206
199	0	10	3.0	3	0.257	1.0932	0.0246	0.5706
214	3	10	1.5	5	0.240	0.6403	0.0171	0.3182
215	3	10	3.0	3	0.237	0.9827	0.0149	0.4757
216	3	10	4.0	3	0.229	1.0155	0.0110	0.4742
184	6	10	1.5	6	0.234	0.6070	0.0143	0.2944
185	6	10	3.0	4	0.212	0.8213	0.0037	0.3582
186	6	10	3.0	5	0.214	0.7028	0.0048	0.3108
188	6	10	4.0	4	0.199	0.7622	-0.0017	0.3128
201	0	15	1.5	4	0.244	0.8484	0.0187	0.4254
202	0	15	3.0	2	0.271	1.1794	0.0317	0.6460
217	3	15	1.5	4	0.245	0.8052	0.0193	0.4061
218	3	15	3.0	3	0.246	1.0914	0.0190	0.5453
189	6	15	1.5	5	0.236	0.7017	0.0151	0.3422
191	6	15	3.0	4	0.214	0.8524	0.0045	0.3748
193	6	15	4.0	4	0.200	0.8042	-0.0013	0.3311

\* rps = radians per second

TABLE 2.3

## ROLL EXTINCTION RESULTS - 10 DEGREES DEADRISE

SPRING STIFFNESS 63.3 lb-ft per radian

Run	Trim deg	Yaw deg	Cv	No. of Cycles	Roll Period seconds	Logarithmic Decrement	Added Inertia slug-ft.sq	Damping lb-ft/rps*
32	0	0	1.5	7	0.190	0.4516	0.0178	0.2867
33	0	0	3.0	6	0.196	0.4997	0.0216	0.3269
118	0	0	4.0	5	0.196	0.7641	0.0211	0.4957
34	0	0	4.0	3	0.194	0.7897	0.0197	0.5066
85	3	0	1.5	9	0.189	0.3490	0.0173	0.2209
86	3	0	3.0	5	0.188	0.7033	0.0161	0.4386
87	3	0	4.0	6	0.181	0.5918	0.0120	0.3566
43	6	0	1.5	8	0.181	0.3918	0.0123	0.2373
44	6	0	3.0	5	0.170	0.6414	0.0055	0.3625
46	6	0	4.0	7	0.158	0.4765	-0.0008	0.2514
45	6	0	4.0	7	0.157	0.4822	-0.0013	0.2528
72	0	10	1.5	7	0.189	0.5055	0.0171	0.3188
73	0	10	3.0	3	0.203	1.0421	0.0249	0.6915
75	0	10	3.0	4	0.201	0.9712	0.0238	0.6404
74	0	10	4.0	3	0.197	1.3589	0.0198	0.8590
90	3	10	1.5	7	0.190	0.5126	0.0177	0.3250
91	3	10	3.0	4	0.182	0.7782	0.0123	0.4685
115	3	10	4.0	4	0.176	0.8410	0.0086	0.4884
92	3	10	4.0	3	0.179	0.8395	0.0104	0.4959
64	6	10	1.5	7	0.182	0.4979	0.0128	0.3025
65	6	10	3.0	5	0.169	0.6150	0.0050	0.3458
66	6	10	4.0	7	0.158	0.5058	-0.0008	0.2667
77	0	15	1.5	5	0.194	0.7344	0.0199	0.4721
94	3	15	1.5	5	0.194	0.7364	0.0199	0.4733
95	3	15	3.0	4	0.189	0.8508	0.0164	0.5304
97	3	15	4.0	4	0.191	0.9161	0.0175	0.5755
68	6	15	1.5	6	0.184	0.5780	0.0139	0.3542
69	6	15	3.0	5	0.169	0.6569	0.0049	0.3688
70	6	15	4.0	5	0.155	0.5595	-0.0025	0.2890

\* rps = radians per second

TABLE 3.1

## ROLL EXTINCTION RESULTS - 20 DEGREE DEADRISE

SPRING STIFFNESS 22.9 lb-ft per radian

Run	Trim deg	Yaw deg	Cv	No. of Cycles	Roll Period seconds	Logarithmic Decrement	Added Inertia slug-ft.sq	Damping lb-ft/rps*
308	0	0	1.5	6	0.274	0.5672	0.0099	0.2023
309	0	0	3.0	3	0.288	1.0536	0.0140	0.3873
310	0	0	4.0	3	0.277	1.1814	0.0097	0.4147
311	0	0	4.0	3	0.288	1.0688	0.0140	0.3925
329	3	0	1.5	5	0.282	0.7630	0.0125	0.2782
332	3	0	3.0	3	0.284	0.9668	0.0128	0.3519
330	3	0	3.0	4	0.280	0.9009	0.0115	0.3243
331	3	0	4.0	3	0.268	1.0421	0.0069	0.3566
296	6	0	1.5	7	0.272	0.5059	0.0093	0.1794
297	6	0	3.0	4	0.260	0.8982	0.0046	0.3003
298	6	0	4.0	4	0.238	0.7653	-0.0023	0.2355
320	0	10	1.5	5	0.293	0.6579	0.0168	0.2502
321	0	10	3.0	2	0.307	1.2046	0.0207	0.4680
333	3	10	1.5	5	0.286	0.7245	0.0140	0.2683
334	3	10	3.0	3	0.272	1.2030	0.0079	0.4142
335	3	10	4.0	2	0.278	1.2598	0.0098	0.4418
299	6	10	1.5	5	0.275	0.6289	0.0102	0.2247
300	6	10	1.5	5	0.276	0.6164	0.0106	0.2211
301	6	10	3.0	4	0.258	0.8334	0.0040	0.2772
303	6	10	4.0	5	0.234	0.6754	-0.0034	0.2050
302	6	10	4.0	4	0.237	0.7315	-0.0026	0.2244
323	0	15	1.5	5	0.292	0.7131	0.0163	0.2697
337	3	15	1.5	5	0.290	0.6600	0.0157	0.2484
304	6	15	1.5	4	0.276	0.7373	0.0104	0.2634
305	6	15	3.0	3	0.254	1.1170	0.0021	0.3609
306	6	15	4.0	4	0.226	0.7537	-0.0059	0.2203

\* rps = radians per second

TABLE 3.2

## ROLL EXTINCTION RESULTS - 20 DEGREE DEADRISE

SPRING STIFFNESS 38.3 lb-ft per radian

Run	Trim deg	Yaw deg	Cv	No. of Cycles	Roll Period seconds	Logarithmic Decrement	Added Inertia slug-ft.sq	Damping lb-ft/rps*
358	0	0	1.5	6	0.223	0.5385	0.0127	0.2494
359	0	0	3.0	3	0.229	1.0599	0.0144	0.4938
360	0	0	4.0	5	0.222	0.9290	0.0115	0.4223
342	3	0	1.5	6	0.222	0.5967	0.0122	0.2747
343	3	0	3.0	4	0.218	0.8331	0.0099	0.3734
345	3	0	4.0	4	0.211	0.9236	0.0067	0.3991
367	6	0	1.5	7	0.219	0.4852	0.0110	0.2210
368	6	0	3.0	5	0.208	0.7762	0.0057	0.3327
369	6	0	4.0	6	0.194	0.6676	0.0000	0.2680
363	0	10	1.5	6	0.229	0.6109	0.0154	0.2900
361	0	10	1.5	6	0.229	0.6165	0.0154	0.2926
346	3	10	1.5	6	0.226	0.5924	0.0141	0.2777
347	3	10	3.0	3	0.217	1.1127	0.0089	0.4898
348	3	10	4.0	3	0.216	0.8636	0.0090	0.3831
370	6	10	1.5	6	0.222	0.5459	0.0123	0.2517
371	6	10	3.0	5	0.208	0.6911	0.0058	0.2972
372	6	10	4.0	5	0.190	0.6742	-0.0016	0.2650
364	0	15	1.5	5	0.236	0.6661	0.0187	0.3253
349	3	15	1.5	5	0.232	0.6644	0.0168	0.3189
351	3	15	3.0	4	0.222	0.9248	0.0116	0.4204
353	3	15	3.0	4	0.220	0.8854	0.0107	0.3996
352	3	15	4.0	3	0.211	0.9473	0.0066	0.4089
373	6	15	1.5	5	0.222	0.6465	0.0121	0.2971
374	6	15	3.0	4	0.203	0.8429	0.0034	0.3517
375	6	15	4.0	5	0.189	0.6843	-0.0020	0.2674

\* rps = radians per second

TABLE 3.3

## ROLL EXTINCTION RESULTS - 20 DEGREE DEADRISE

SPRING STIFFNESS 63.3 lb-ft per radian

Run	Trim deg	Yaw deg	Cv	No. of Cycles	Roll Period seconds	Logarithmic Decrement	Added Inertia slug-ft.sq	Damping lb-ft/rps*
380	0	0	1.5	8	0.177	.4173	0.0135	0.2470
381	0	0	3.0	4	0.173	.8332	0.0105	0.4758
382	0	0	4.0	4	0.169	.7957	0.0083	0.4445
401	3	0	1.5	7	0.173	.4957	0.0110	0.2863
402	3	0	3.0	6	0.166	.5915	0.0070	0.3269
403	3	0	4.0	5	0.163	.6388	0.0053	0.3462
404	3	0	4.0	6	0.164	.6111	0.0058	0.3335
388	6	0	1.5	7	0.171	.4668	0.0099	0.2666
389	6	0	3.0	6	0.160	.5578	0.0037	0.2974
390	6	0	4.0	9	0.152	.3993	-0.0003	0.2030
383	0	10	1.5	8	0.177	.4394	0.0134	0.2600
384	0	10	3.0	4	0.190	.9519	0.0204	0.5938
405	3	10	1.5	5	0.177	.5274	0.0133	0.3113
407	3	10	3.0	4	0.168	.7708	0.0078	0.4285
406	3	10	3.0	4	0.170	.7785	0.0089	0.4378
408	3	10	4.0	4	0.165	.8251	0.0060	0.4495
394	6	10	1.5	6	0.172	.5011	0.0105	0.2877
395	6	10	3.0	5	0.160	.6167	0.0037	0.3283
396	6	10	4.0	8	0.152	.4577	-0.0003	0.2324
385	0	15	1.5	7	0.183	.5177	0.0170	0.3161
386	0	15	3.0	3	0.207	1.2711	0.0302	0.8490
409	3	15	1.5	6	0.178	.5516	0.0139	0.3273
410	3	15	3.0	4	0.171	.9046	0.0092	0.5090
411	3	15	4.0	4	0.167	.9295	0.0069	0.5102
397	6	15	1.5	6	0.173	.5733	0.0109	0.3304
398	6	15	3.0	6	0.161	.6341	0.0042	0.3394
399	6	15	4.0	7	0.149	.4783	-0.0018	0.2380

\* rps = radians per second

TABLE 4.1

## ADDED INERTIA AT 10 DEGREES DEADRISE

---- ADDED INERTIA IN ROLL, slug-ft.sq ----

Yaw deg	Trim deg	Cv	Spring Stiffness, lb-ft/rad			Average	Formula	Mean Wetted Length, in.
			22.9	38.3	63.3			
0	0	1.5	0.0135	0.0140	0.0178	0.0151	0.0189	43.8
0	0	3.0	0.0197	0.0209	0.0216	0.0207	0.0185	42.9
0	0	4.0	0.0245	0.0015*	0.0211	0.0218	0.0188	43.6
0	0	4.0	-	-	0.0197	0.0218	0.0188	43.6
0	3	1.5	0.0138	0.0145	0.0173	0.0152	0.0156	36.1
0	3	3.0	0.0149	0.0133	0.0161	0.0148	0.0130	30.2
0	3	4.0	0.0138	0.0092	0.0120	0.0114	0.0094	21.8
0	3	4.0	0.0107	-	-	0.0114	0.0094	21.8
0	6	1.5	0.0130	0.0121	0.0123	0.0125	0.0114	26.3
0	6	3.0	0.0082	0.0055	0.0055	0.0064	0.0054	12.5
0	6	4.0	-0.0011	-0.0012	-0.0008	-0.0011	0.0023	5.4
0	6	4.0	-	-	-0.0013	-0.0011	0.0023	5.4
10	0	1.5	0.0186	0.0166	0.0171	0.0174	0.0192	44.5
10	0	3.0	-	0.0246	0.0249	0.0244	0.0201	46.5
10	0	3.0	-	-	0.0238	0.0244	0.0201	46.5
10	0	4.0	-	-	0.0198	0.0198	0.0201	46.5
10	3	1.5	0.0179	0.0171	0.0177	0.0176	0.0161	37.3
10	3	3.0	0.0104	0.0149	0.0123	0.0125	0.0133	30.9
10	3	4.0	0.0147	0.0110	0.0086	0.0112	0.0096	22.3
10	3	4.0	-	-	0.0104	0.0112	0.0096	22.3
10	6	1.5	0.0138	0.0143	0.0128	0.0136	0.0119	27.6
10	6	3.0	0.0055	0.0037	0.0050	0.0048	0.0056	13.0
10	6	3.0	-	0.0048	-	0.0048	0.0056	13.0
10	6	4.0	-0.0029	-0.0017	-0.0008	-0.0028	0.0024	5.6
10	6	4.0	-0.0056	-	-	-0.0028	0.0024	5.6
15	0	1.5	0.0196	0.0187	0.0199	0.0194	0.0203	47.0
15	0	3.0	-	0.0317	-	0.0137	0.0203	47.0
15	3	1.5	0.0235	0.0193	0.0199	0.0209	0.0166	38.5
15	3	3.0	0.0113	0.0190	0.0164	0.0156	0.0143	33.2
15	3	3.0	0.0158	-	-	0.0156	0.0143	33.2
15	3	4.0	0.0075	-	0.0175	0.0125	0.0108	25.0
15	6	1.5	0.0167	0.0151	0.0139	0.0152	0.0123	28.6
15	6	3.0	0.0048	0.0045	0.0049	0.0052	0.0049	11.4
15	6	3.0	0.0064	-	-	0.0052	0.0049	11.4
15	6	4.0	-0.0061	-0.0013	-0.0025	-0.0038	0.0026	6.0
15	6	4.0	-0.0052	-	-	-0.0038	0.0026	6.0

\* Outlying value not included in average

TABLE 4.2

## ADDED INERTIA AT 20 DEGREES DEADRISE

---- ADDED INERTIA IN ROLL, slug-ft.sq ----

Yaw deg	Trim deg	Cv	Spring Stiffness, lb-ft/rad			Average	Formula	Mean Wetted Length, in.
			22.9	38.3	63.3			
0	0	1.5	0.0099	0.0127	0.0135	0.0121	0.0148	43.0
0	0	3.0	0.0140	0.0144	0.0105	0.0130	0.0143	41.6
0	0	4.0	0.0097	0.0115	0.0083	0.0109	0.0139	40.4
0	0	4.0	0.0140	-	-	0.0109	0.0139	40.4
0	3	1.5	0.0125	0.0122	0.0110	0.0119	0.0122	35.4
0	3	3.0	0.0128	0.0099	0.0070	0.0103	0.0103	29.9
0	3	3.0	0.0115	-	-	0.0103	0.0103	29.9
0	3	4.0	0.0069	0.0067	0.0053	0.0062	0.0083	24.0
0	3	4.0	-	-	0.0058	0.0062	0.0083	24.0
0	6	1.5	0.0093	0.0110	0.0099	0.0101	0.0091	26.6
0	6	3.0	0.0046	0.0057	0.0037	0.0047	0.0050	14.4
0	6	4.0	-0.0023	0.0000	-0.0003	-0.0008	0.0026	7.5
10	0	1.5	0.0168	0.0154	0.0134	0.0152	0.0152	44.2
10	0	1.5	-	0.0154	-	0.0152	0.0152	44.2
10	0	3.0	0.0207	-	0.0204	0.0205	0.0164	47.7
10	3	1.5	0.0140	0.0141	0.0133	0.0138	0.0124	36.2
10	3	3.0	0.0079	0.0089	0.0078	0.0084	0.0110	31.9
10	3	3.0	-	-	0.0089	0.0084	0.0110	31.9
10	3	4.0	0.0098	0.0090	0.0060	0.0083	0.0094	27.2
10	6	1.5	0.0102	0.0123	0.0105	0.0109	0.0096	27.8
10	6	1.5	0.0106	-	-	0.0109	0.0096	27.8
10	6	3.0	0.0040	0.0058	0.0037	0.0045	0.0055	16.0
10	6	4.0	-0.0034	-0.0016	-0.0003	-0.0020	0.0026	7.7
10	6	4.0	-0.0026	-	-	-0.0020	0.0026	7.7
15	0	1.5	0.0163	0.0187	0.0170	0.0173	0.0155	45.2
15	0	3.0	-	-	0.0302	0.0302	0.0163	47.3
15	3	1.5	0.0157	0.0168	0.0139	0.0154	0.0129	37.5
15	3	3.0	-	0.0116	0.0092	0.0105	0.0122	35.6
15	3	3.0	-	0.0107	-	0.0105	0.0122	35.6
15	3	4.0	-	0.0066	0.0069	0.0068	0.0118	34.4
15	6	1.5	0.0104	0.0121	0.0109	0.0111	0.0101	29.3
15	6	3.0	0.0021	0.0034	0.0042	0.0032	0.0061	17.8
15	6	4.0	-0.0059	-0.0020	-0.0018	-0.0032	0.0028	8.1

TABLE 5.1

## ROLL DAMPING AT 10 DEGREES DEADRISE

-- ROLL DAMPING, lb-ft/radians per second --

Yaw deg	Trim deg	Cv	Spring Stiffness, lb-ft/rad			Average	Formula	Mean Wetted Length, in.
			22.9	38.3	63.3			
0	0	1.5	0.1955	0.2162	0.2867	0.2328	0.3487	43.8
0	0	3.0	0.2235	0.2690	0.3269	0.2731	0.4522	42.9
0	0	4.0	0.3208	0.3676	0.4957	0.4227	0.5283	43.6
0	0	4.0	-	-	0.5066	0.4227	0.5283	43.6
0	3	1.5	0.2018	0.2220	0.2209	0.2149	0.3065	36.1
0	3	3.0	0.3580	0.3963	0.4386	0.3976	0.3825	30.2
0	3	4.0	0.4405	0.4495	0.3566	0.4236	0.4087	21.8
0	3	4.0	0.4477	-	-	0.4236	0.4087	21.8
0	6	1.5	0.2165	0.2111	0.2373	0.2216	0.2527	26.3
0	6	3.0	0.3906	0.3536	0.3625	0.3689	0.2854	12.5
0	6	4.0	0.3498	0.2988	0.2514	0.2882	0.3188	5.4
0	6	4.0	-	-	0.2528	0.2882	0.3188	5.4
10	0	1.5	0.2786	0.3206	0.3188	0.3060	0.4105	44.5
10	0	3.0	-	0.5706	0.6915	0.6342	0.5299	46.5
10	0	3.0	-	-	0.6404	0.6342	0.5299	46.5
10	0	4.0	-	-	0.8590	0.8590	0.6021	46.5
10	3	1.5	0.3245	0.3182	0.3250	0.3226	0.3710	37.3
10	3	3.0	0.4791	0.4757	0.4685	0.4744	0.4443	30.9
10	3	4.0	0.5116	0.4742	0.4884	0.4925	0.4694	22.3
10	3	4.0	-	-	0.4959	0.4925	0.4694	22.3
10	6	1.5	0.2785	0.2944	0.3025	0.2918	0.3178	27.6
10	6	3.0	0.3085	0.3582	0.3458	0.3308	0.3461	13.0
10	6	3.0	-	0.3108	-	0.3308	0.3461	13.0
10	6	4.0	0.3360	0.3128	0.2667	0.3055	0.3778	5.6
10	6	4.0	0.3065	-	-	0.3055	0.3778	5.6
15	0	1.5	0.4183	0.4254	0.4721	0.4386	0.4526	47.0
15	0	3.0	-	0.6460	-	0.6460	0.5610	47.0
15	3	1.5	0.4021	0.4061	0.4733	0.4272	0.4060	38.5
15	3	3.0	0.4988	0.5453	0.5304	0.5246	0.4853	33.2
15	3	3.0	0.5237	-	-	0.5246	0.4853	33.2
15	3	4.0	0.5673	-	0.5755	0.5714	0.5126	25.0
15	6	1.5	0.3756	0.3422	0.3542	0.3574	0.3516	28.6
15	6	3.0	0.3504	0.3748	0.3688	0.3578	0.3657	11.4
15	6	3.0	0.3370	-	-	0.3578	0.3657	11.4
15	6	4.0	0.2740	0.3311	0.2890	0.2946	0.4084	6.0
15	6	4.0	0.2842	-	-	0.2946	0.4084	6.0

TABLE 5.2

## ROLL DAMPING AT 20 DEGREES DEADRISE

-- ROLL DAMPING, lb-ft/radians per second --

Yaw deg	Trim deg	Cv	Spring Stiffness, lb-ft/rad			Average	Formula	Mean Wetted Length, in.
			22.9	38.3	63.3			
0	0	1.5	0.2023	0.2494	0.2470	0.2329	0.2742	43.0
0	0	3.0	0.3873	0.4938	0.4758	0.4523	0.3544	41.6
0	0	4.0	0.4147	0.4223	0.4445	0.4185	0.4067	40.4
0	0	4.0	0.3925	-	-	0.4185	0.4067	40.4
0	3	1.5	0.2782	0.2747	0.2863	0.2797	0.2410	35.4
0	3	3.0	0.3519	0.3734	0.3269	0.3441	0.3033	29.9
0	3	3.0	0.3243	-	-	0.3441	0.3033	29.9
0	3	4.0	0.3566	0.3991	0.3462	0.3588	0.3351	24.0
0	3	4.0	-	-	0.3335	0.3588	0.3351	24.0
0	6	1.5	0.1794	0.2210	0.2666	0.2223	0.2025	26.6
0	6	3.0	0.3003	0.3327	0.2974	0.3101	0.2356	14.4
0	6	4.0	0.2355	0.2680	0.2030	0.2355	0.2630	7.5
10	0	1.5	0.2502	0.2900	0.2600	0.2732	0.3255	44.2
10	0	1.5	-	0.2926	-	0.2732	0.3255	44.2
10	0	3.0	0.4680	-	0.5938	0.5309	0.4271	47.7
10	3	1.5	0.2683	0.2777	0.3113	0.2858	0.2906	36.2
10	3	3.0	0.4142	0.4898	0.4285	0.4426	0.3581	31.9
10	3	3.0	-	-	0.4378	0.4426	0.3581	31.9
10	3	4.0	0.4418	0.3831	0.4495	0.4248	0.3952	27.2
10	6	1.5	0.2247	0.2517	0.2877	0.2463	0.2539	27.8
10	6	1.5	0.2211	-	-	0.2463	0.2539	27.8
10	6	3.0	0.2772	0.2972	0.3283	0.3009	0.2887	16.0
10	6	4.0	0.2050	0.2650	0.2324	0.2317	0.3100	7.7
10	6	4.0	0.2244	-	-	0.2317	0.3100	7.7
15	0	1.5	0.2697	0.3253	0.3161	0.3037	0.3525	45.2
15	0	3.0	-	-	0.8490	0.8490	0.4480	47.3
15	3	1.5	0.2484	0.3189	0.3273	0.2982	0.3189	37.5
15	3	3.0	-	0.4204	0.5090	0.4430	0.3969	35.6
15	3	3.0	-	0.3996	-	0.4430	0.3969	35.6
15	3	4.0	-	0.4089	0.5102	0.4596	0.4492	34.4
15	6	1.5	0.2634	0.2971	0.3304	0.2970	0.2831	29.3
15	6	3.0	0.3609	0.3517	0.3394	0.3507	0.3192	17.8
15	6	4.0	0.2203	0.2674	0.2380	0.2419	0.3343	8.1

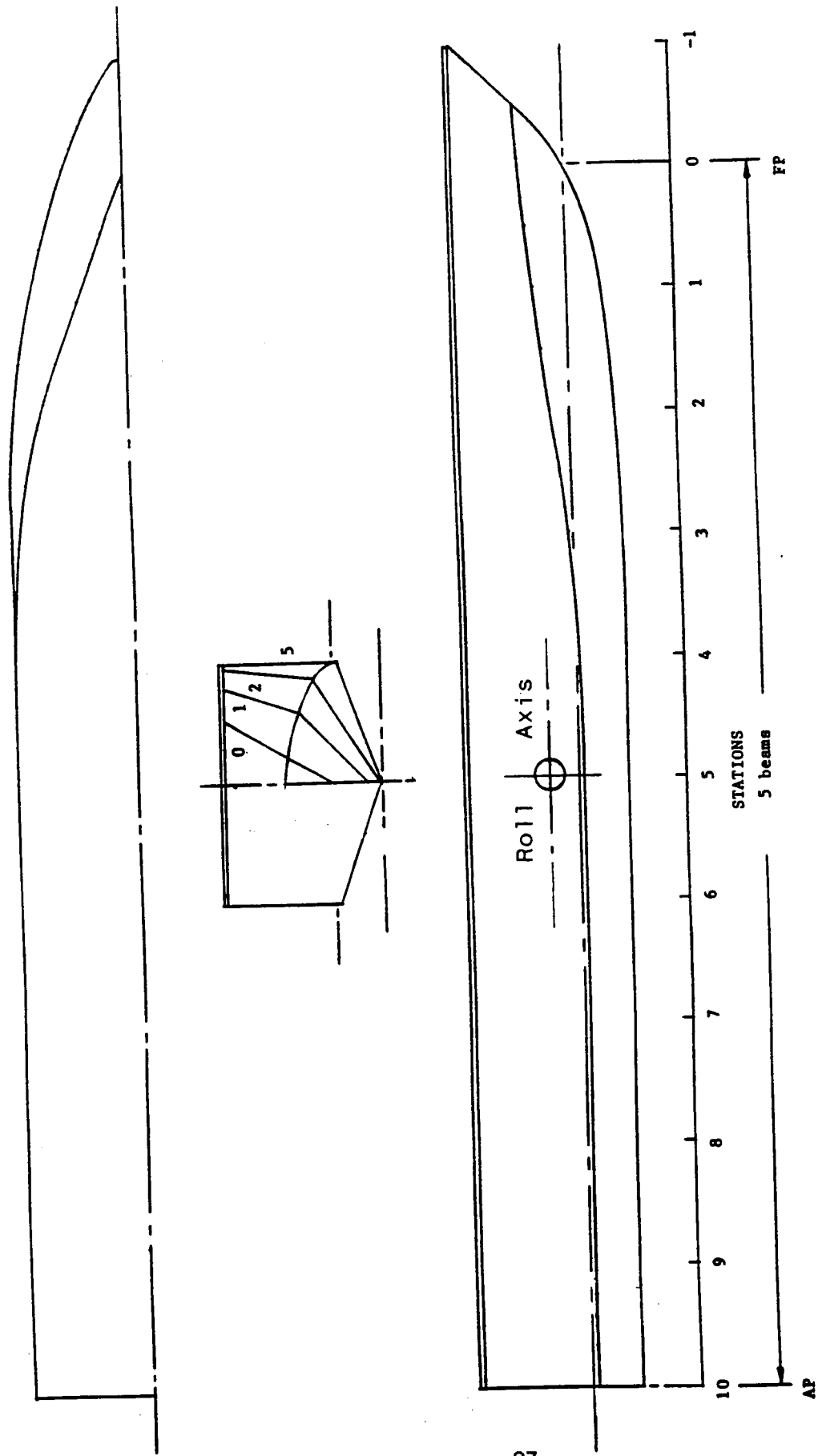

FIGURE 1 LINES OF 20° DEADRISE PARENT MODEL

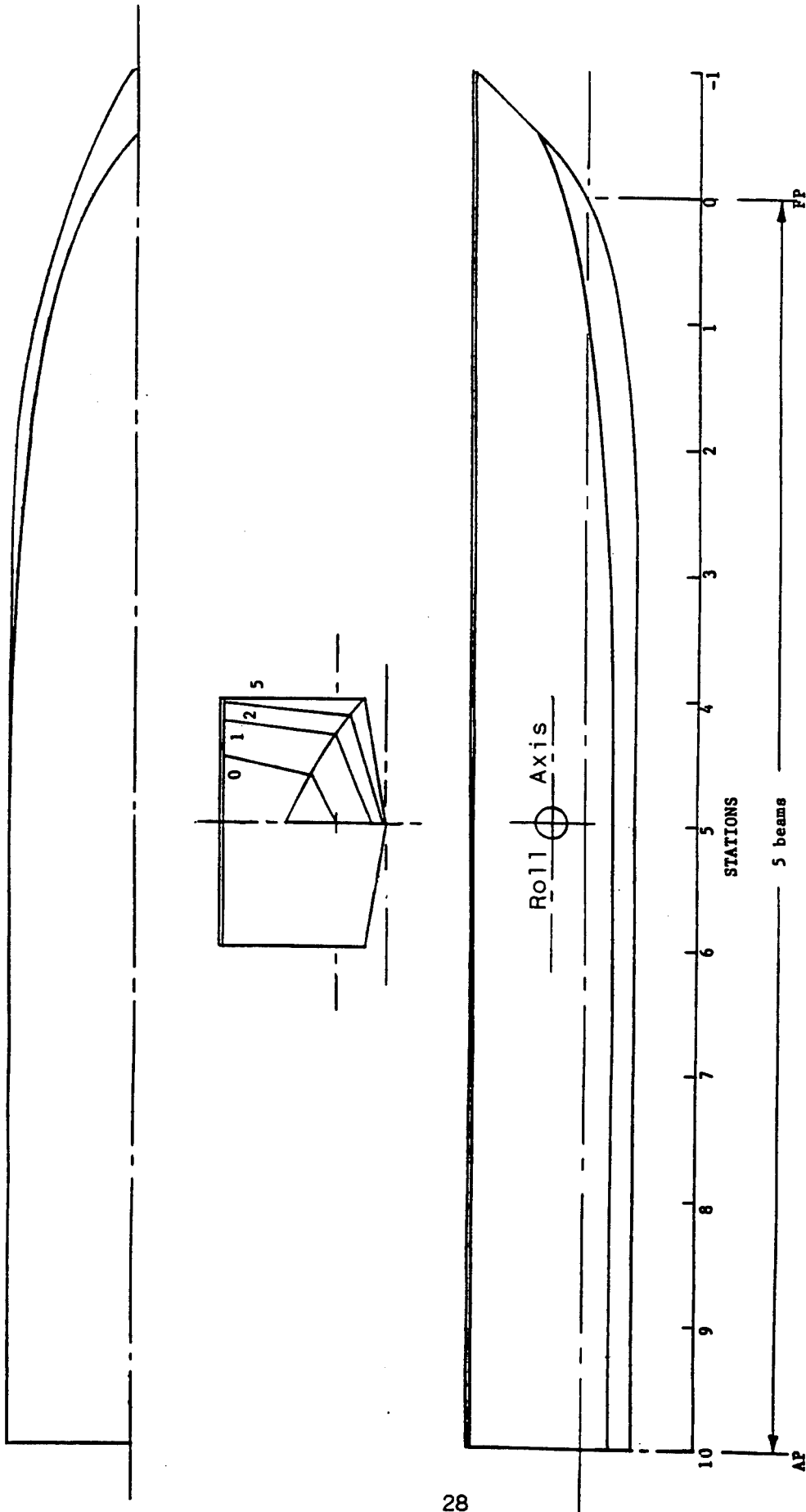

FIGURE 2 LINES OF 10° DEADRISE MODEL

R-2632

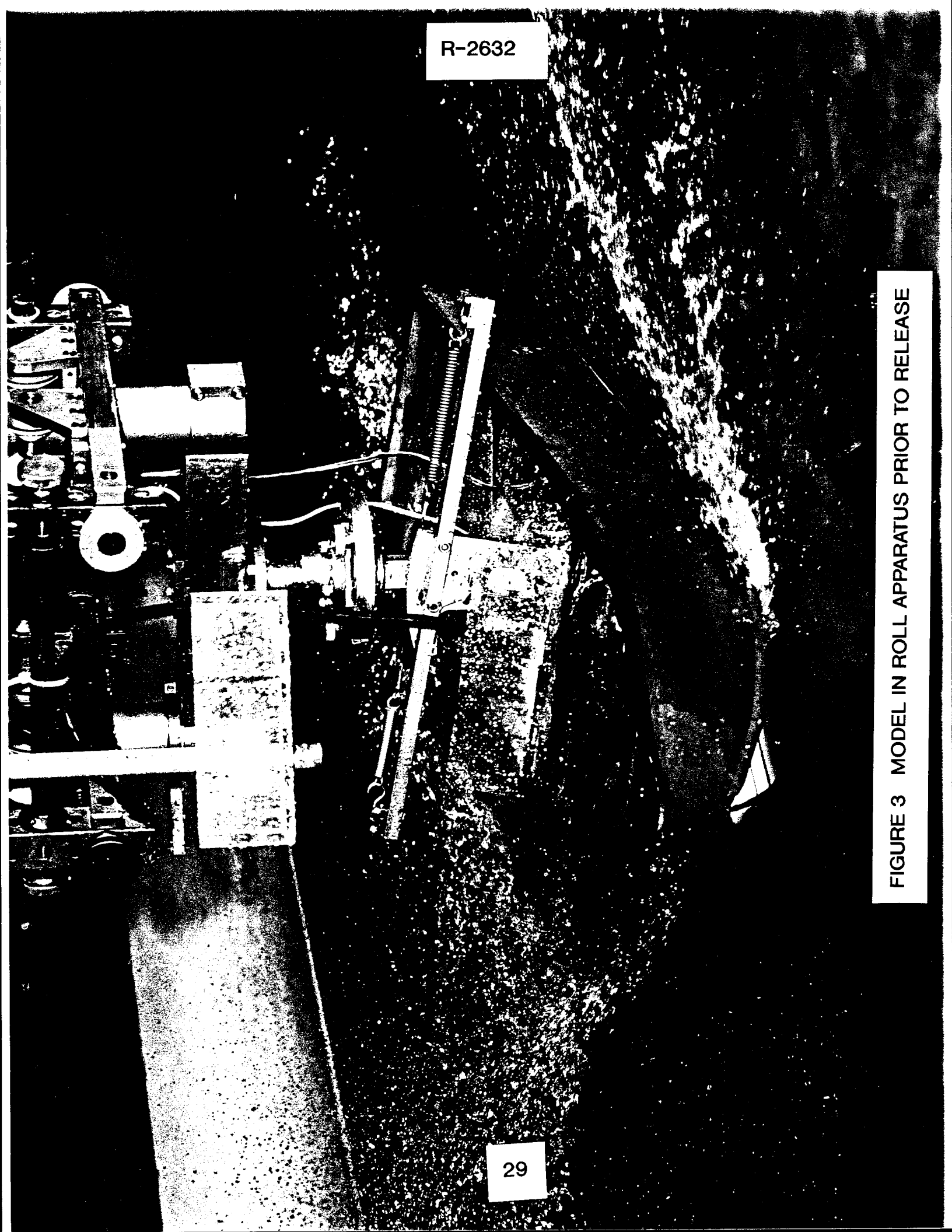

FIGURE 3 MODEL IN ROLL APPARATUS PRIOR TO RELEASE

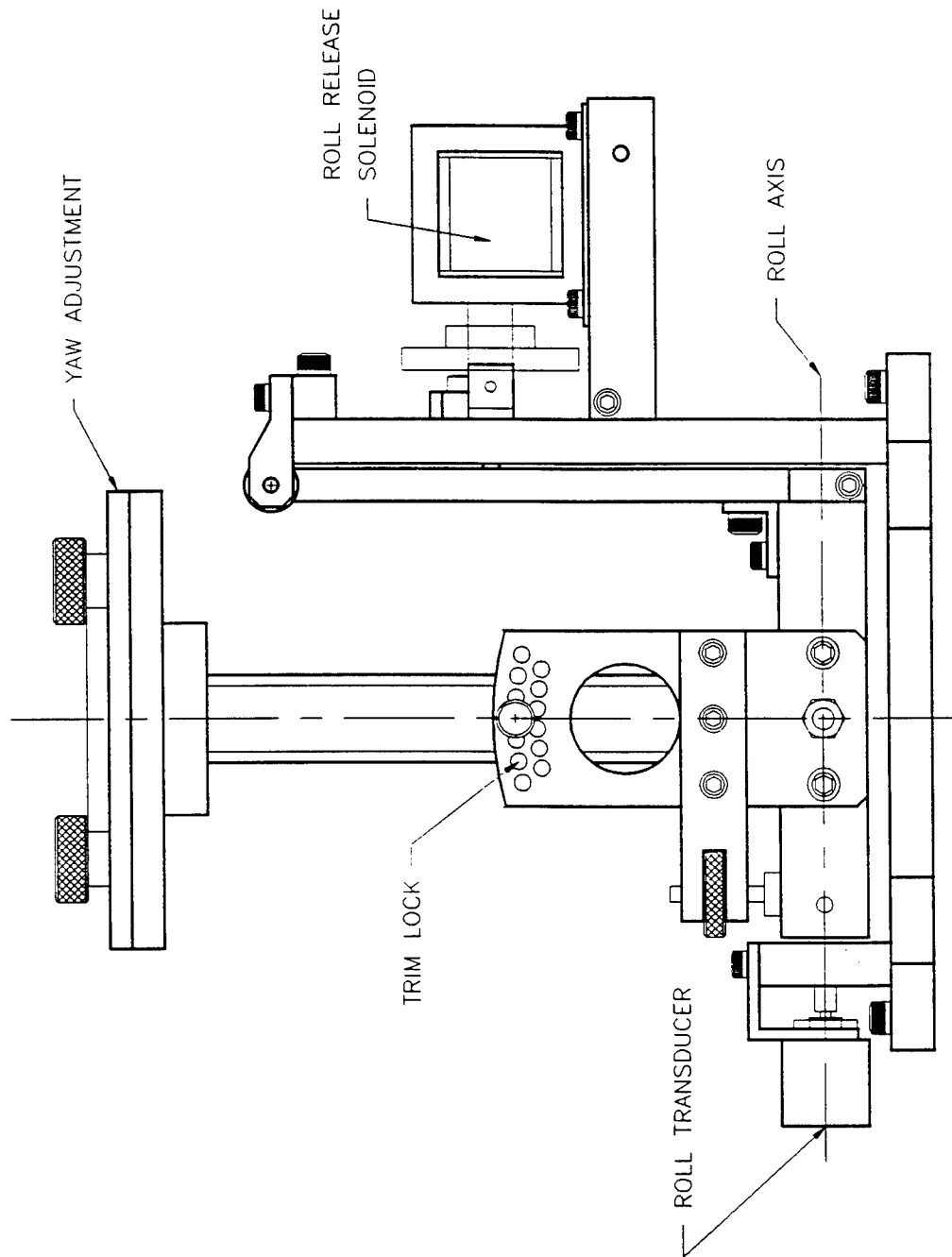

FIGURE 4A SIDE VIEW OF ROLL OSCILLATION APPARATUS

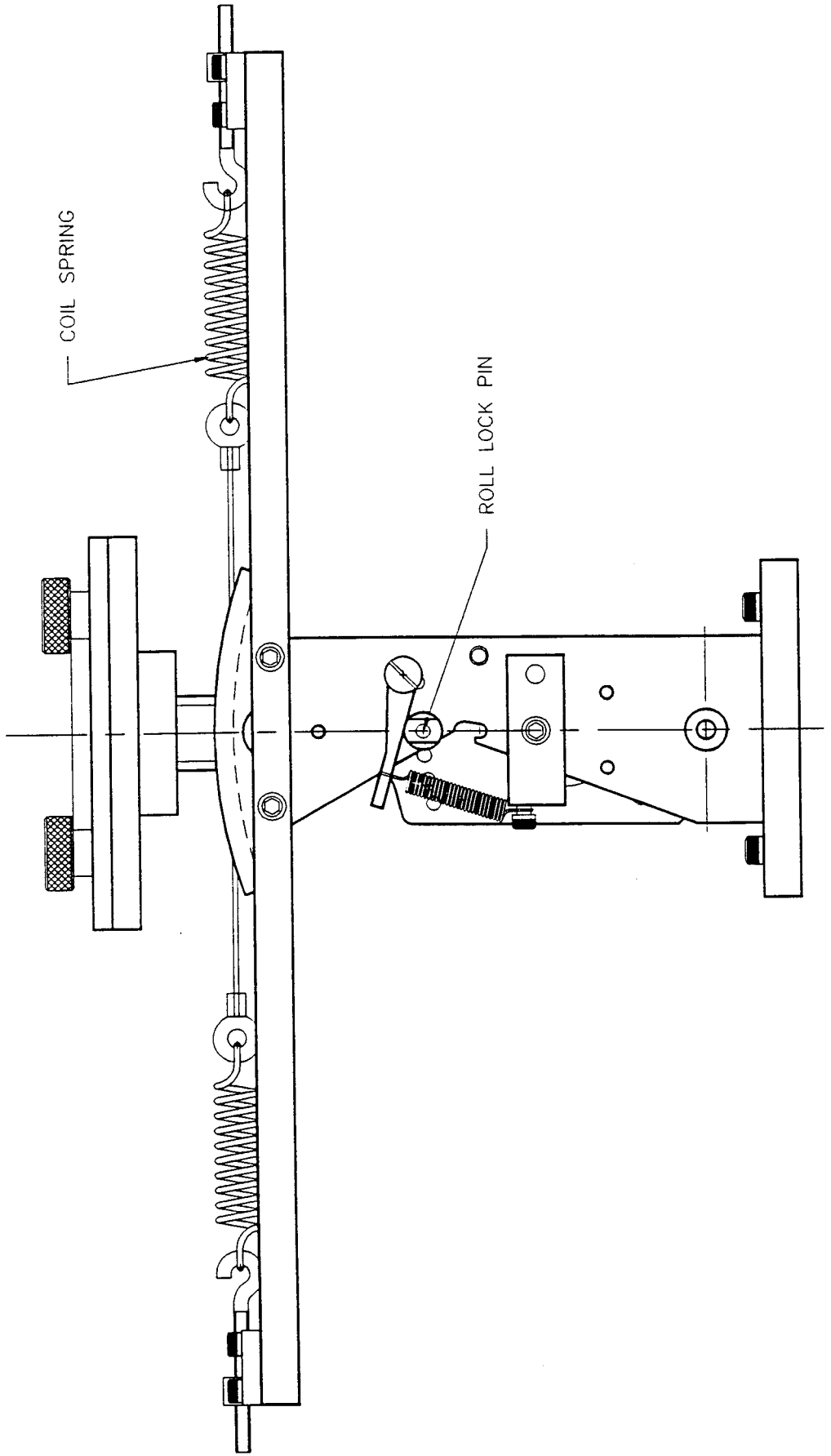
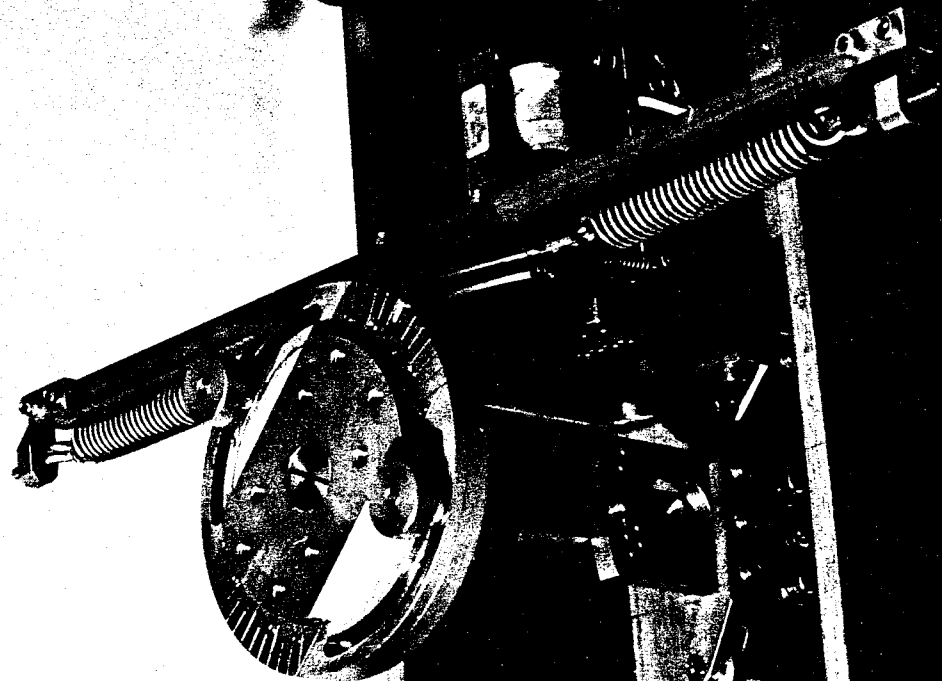

FIGURE 4B END VIEW OF ROLL OSCILLATION APPARATUS

R-2632



32

FIGURE 5 INSTALLATION OF ROLL APPARATUS IN MODEL

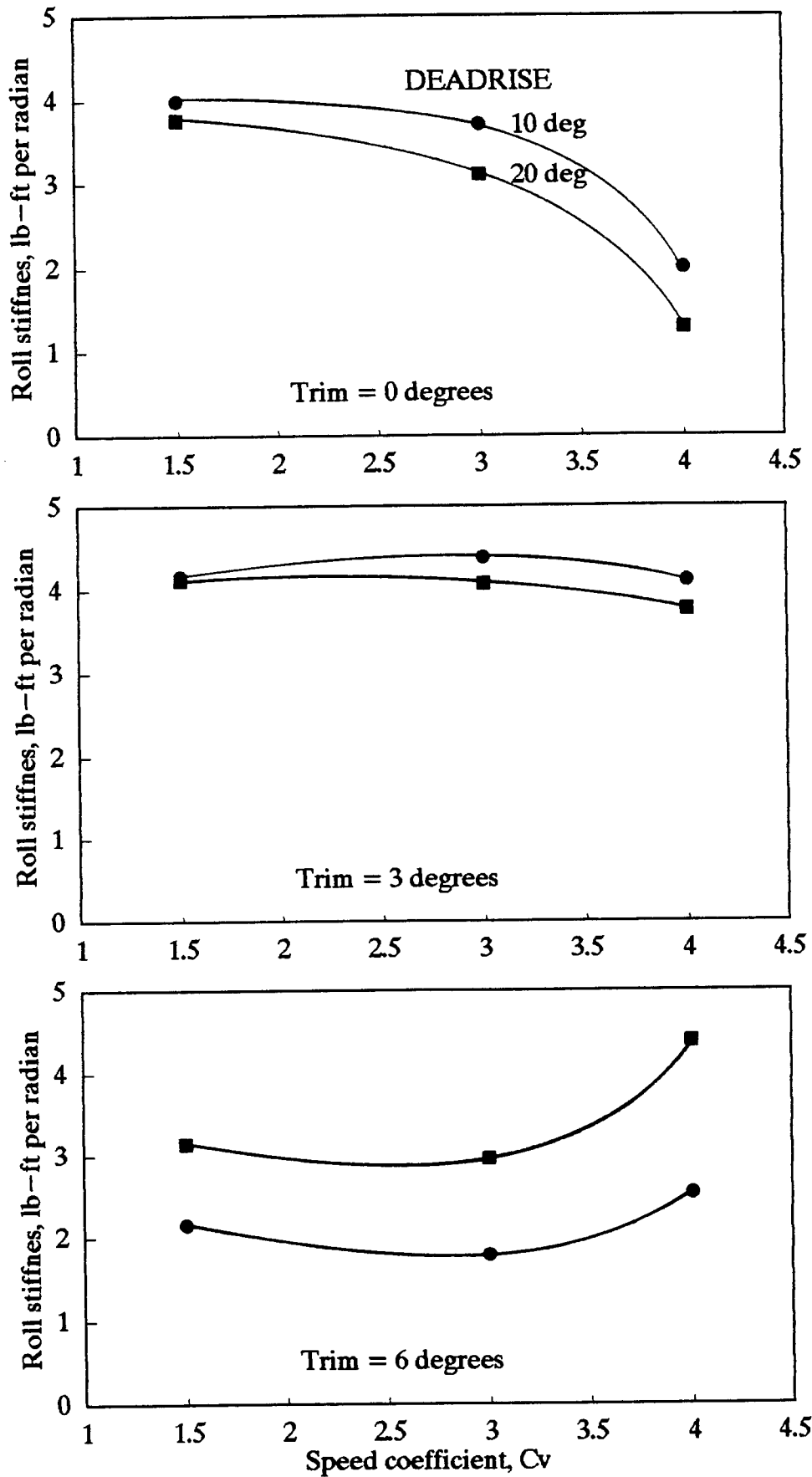

FIGURE 6 VARIATION OF ROLL STIFFNESS WITH SPEED AT ZERO YAW

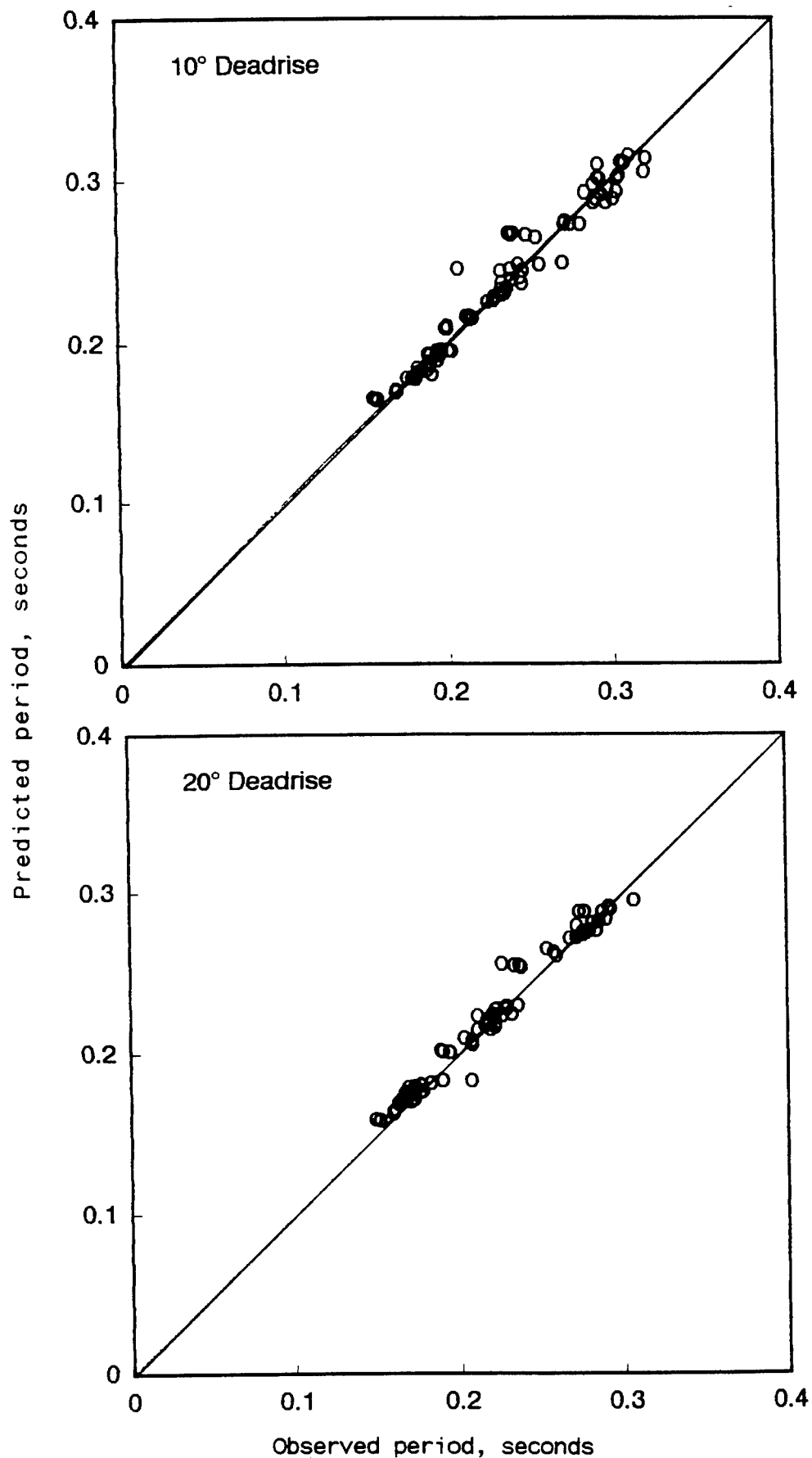

FIGURE 7 COMPARISON OF OBSERVED AND PREDICTED PERIODS

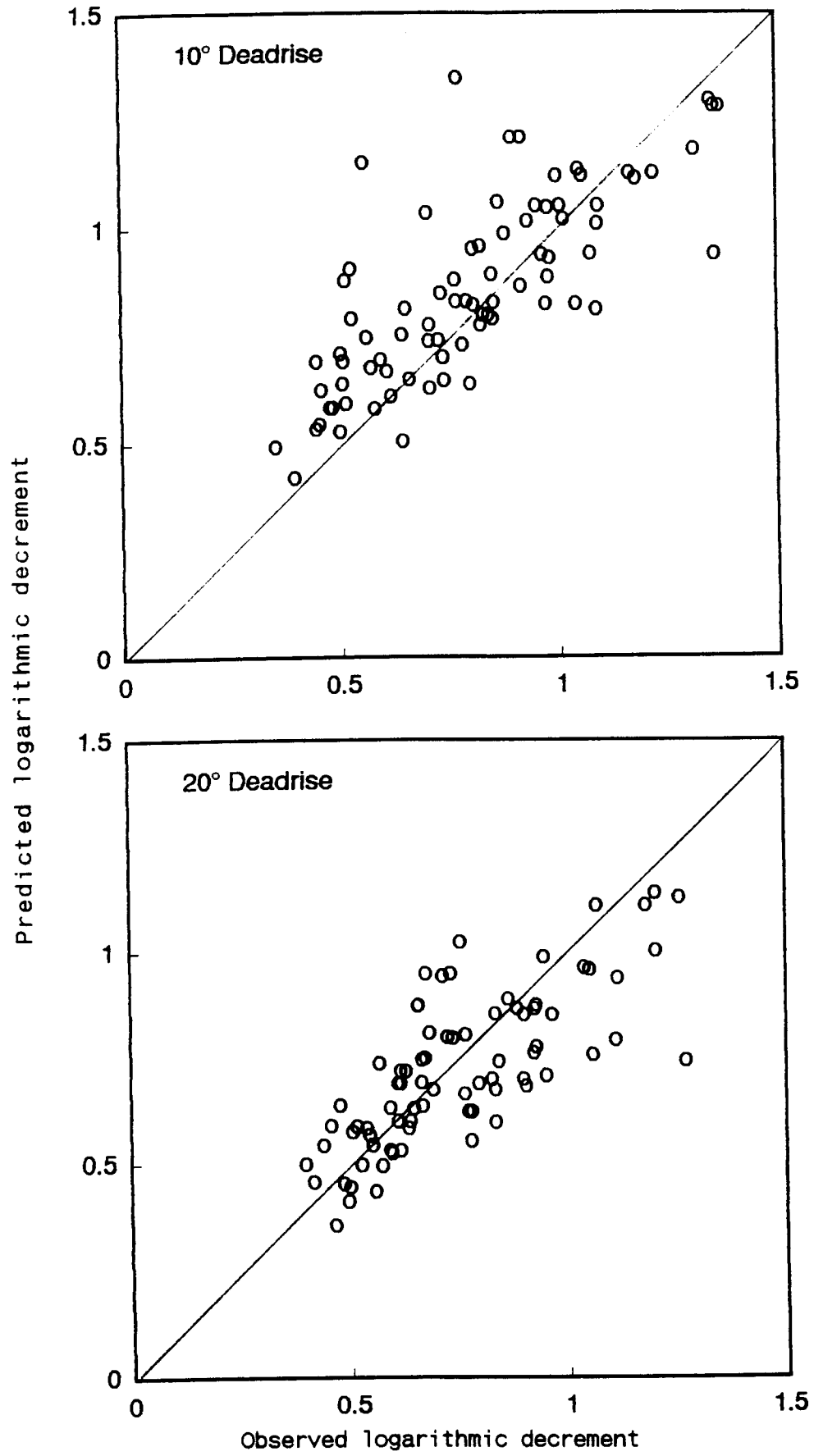

FIGURE 8 COMPARISON OF OBSERVED AND PREDICTED DECREMENTS

