

WL-TR-94-2082

ADVANCED LUBRICANT SEGREGATION CAPABILITY
FOR PROTOTYPE OIL COLLECTION FACILITY

VOLUME 1



ROBERT E. KAUFFMAN
LARRY SQROW
JOSEPH T. SWARTZBAUGH
J. DOUGLAS WOLF

UNIVERSITY OF DAYTON RESEARCH INSTITUTE
300 COLLEGE PARK
DAYTON OH 45469-0104

AUGUST 1994

FINAL REPORT FOR FEBRUARY 1, 1993 - FEBRUARY 1, 1994

APPROVED FOR PUBLIC RELEASE; DISTRIBUTION IS UNLIMITED

19950313 045



AEROPROPULSION AND POWER DIRECTORATE
WRIGHT LABORATORY
AIR FORCE MATERIEL COMMAND
WRIGHT PATTERSON AFB OH 45433-7251

2025 RELEASE UNDER E.O. 14176

NOTICE

When Government drawings, specifications, or other data are used for any purpose other than in connection with a definitely Government-related procurement, the United States Government incurs no responsibility or any obligation whatsoever. The fact that the government may have formulated or in any way supplied the said drawings, specifications, or other data, is not to be regarded by implication, or otherwise in any manner construed, as licensing the holder, or any other person or corporation; or as conveying any rights or permission to manufacture, use, or sell any patented invention that may in any way be related thereto.

This report is releasable to the National Technical Information Service (NTIS). At NTIS, it will be available to the general public, including foreign nations.

This technical report has been reviewed and is approved for publication.

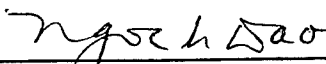

NGOC (TONY) DAO, Project Engineer
Lubrication Branch
Fuels and Lubrication Division

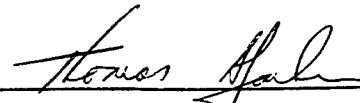

THOMAS A. JACKSON, Chief
Lubrication Branch
Fuels and Lubrication Division



LEO S. HAROOTYAN, JR., Chief
Fuels and Lubrication Division
Aero Propulsion and Power Directorate

If your address has changed, if you wish to be removed from our mailing list, or if the addressee is no longer employed by your organization please notify WL/POSL, WPAFB, OH 45433-7103 to help us maintain a current mailing list.

Copies of this report should not be returned unless return is required by security considerations, contractual obligations, or notice on a specific document.

REPORT DOCUMENTATION PAGE

Form Approved
OMB No. 0704-0188

Public reporting burden for this collection of information is estimated to average 1 hour per response, including the time for reviewing instructions, searching existing data sources, gathering and maintaining the data needed, and completing and reviewing the collection of information. Send comments regarding this burden estimate or any other aspect of this collection of information, including suggestions for reducing this burden, to Washington Headquarters Services, Directorate for Information Operations and Reports, 1215 Jefferson Davis Highway, Suite 1204, Arlington, VA 22202-4302, and to the Office of Management and Budget, Paperwork Reduction Project (0704-0188), Washington, DC 20503.

1. AGENCY USE ONLY (Leave blank)	2. REPORT DATE AUG 1994	3. REPORT TYPE AND DATES COVERED FINAL FEB 1 93 -- FEB 1 94	
4. TITLE AND SUBTITLE ADVANCED LUBRICANT SEGREGATION CAPABILITY FOR PROTOTYPE OIL COLLECTION FACILITY VOLUME 1		5. FUNDING NUMBERS C F33615-92-C-2218 PE 62203 PR 3048 TA 05 WU AL	
6. AUTHOR(S) ROBERT E. KAUFFMAN, LARRY SQROW, JOSEPH T. SWARTZBAUGH, J. DOUGLAS WOLF		8. PERFORMING ORGANIZATION REPORT NUMBER	
7. PERFORMING ORGANIZATION NAME(S) AND ADDRESS(ES) UNIVERSITY OF DAYTON RESEARCH INSTITUTE 300 COLLEGE PARK DAYTON OH 45469-0104		10. SPONSORING / MONITORING AGENCY REPORT NUMBER WL-TR-94-2082	
9. SPONSORING / MONITORING AGENCY NAME(S) AND ADDRESS(ES) AEROPROPULSION AND POWER DIRECTORATE WRIGHT LABORATORY AIR FORCE MATERIEL COMMAND WRIGHT PATTERSON AFB OH 45433-7251		11. SUPPLEMENTARY NOTES	
12a. DISTRIBUTION / AVAILABILITY STATEMENT APPROVED FOR PUBLIC RELEASE; DISTRIBUTION IS UNLIMITED		12b. DISTRIBUTION CODE	
13. ABSTRACT (Maximum 200 words) Studies performed for the Air Force have shown that used oils collected at central collection stations can easily be contaminated by personnel improperly disposing of other materials such as fuels, mineral oil lubricants, silicon oils, hydraulic fluids. This study was performed by the University of Dayton Research Institute to identify and develop sensors that are capable of screening used aircraft engine oils for contaminants such as halogenated and nonhalogenated solvents, fuels, aqueous solutions, and automotive engine oils. The developed sensors were then incorporated into flow-through device. A computer-controlled system is connected to evaluate the sensors capabilities to detect contaminants and degraded oils in used aircraft engine oils entering waste dumps and 55-gallon drums. The success of this development will enable the Air Force to segregate the collected used oils and fluids into well-known composition. This, in turn, will enable the Air Force to sell the waste oils and fluids to reprocessors to increase the economic and environmental benefits of the waste management program.			
14. SUBJECT TERMS AIRCRAFT ENGINE LUBRICANTS SYNTHETIC LUBRICANTS		15. NUMBER OF PAGES 47	
		16. PRICE CODE	
17. SECURITY CLASSIFICATION OF REPORT UNCLASSIFIED	18. SECURITY CLASSIFICATION OF THIS PAGE UNCLASSIFIED	19. SECURITY CLASSIFICATION OF ABSTRACT UNCLASSIFIED	20. LIMITATION OF ABSTRACT UL

TABLE OF CONTENTS

<u>SECTION</u>	<u>PAGE</u>
1 INTRODUCTION	1
2 EXPERIMENTAL	2
2.1 LUBRICATING OILS	2
2.1.1 <u>Aircraft Turbine Engine Oils</u>	2
2.1.2 <u>Automotive and Diesel Engine Oils</u>	2
2.1.3 <u>Hydraulic Fluid</u>	2
2.2 CHEMICALS	2
2.2.1 <u>Solvents</u>	2
2.2.2 <u>Acids</u>	2
2.2.3 <u>Fuels</u>	3
2.3 COMMERCIAL EQUIPMENT	3
2.3.1 <u>Gas Chromatograph</u>	3
2.3.2 <u>Gas Chromatograph-Mass Spectrometer</u>	3
2.3.3 <u>Infrared Spectrophotometer</u>	3
2.3.4 <u>Brookfield Viscometer</u>	4
2.3.5 <u>Visgage Viscometer</u>	4
2.3.6 <u>Kinematic Viscosity Tube</u>	4
2.4 LAB CONSTRUCTED EQUIPMENT	5
2.4.1 <u>Vapor Contaminant Sensor</u>	5
2.4.2 <u>Conductivity Sensor</u>	5
2.4.3 <u>Infrared Sensor</u>	5
2.5 HANDHELD SCREENING DEVICES	8
2.5.1 <u>Vapor Contaminant Screening Device</u>	8
2.5.2 <u>Liquid Conductivity Sensor</u>	8
2.6 FLOW-THROUGH SEGREGATION SYSTEM	9
2.6.1 <u>Cylinder Flow Through</u>	9
2.6.2 <u>Continuous Flow Through</u>	11
3 RESULTS AND DISCUSSION	13
3.1 INTRODUCTION	13
3.2 TASK 1 - USED AIRCRAFT ENGINE OILS	13
3.2.1 <u>Military Base Used Oil Samples</u>	13
3.2.2 <u>Commercial Site Used Oil Samples</u>	15

TABLE OF CONTENTS (continued)

<u>SECTION</u>	<u>PAGE</u>
3.3 TASK 2 - CONTAMINATION SENSORS	17
3.3.1 <u>Identification of Analytical Techniques</u>	17
3.3.1.1 Introduction	17
3.3.1.2 Vapor Contaminant Sensors	17
3.3.1.3 Liquid Conductivity Sensors	18
3.3.1.4 Viscosity Sensors	19
3.3.1.5 Variable Wavelength Infrared Sensors	20
3.3.2 <u>Evaluation of Selected Analytical Techniques</u>	20
3.3.2.1 Solvents and Fluids	20
3.3.2.2 Used Aircraft Engine Oils	22
3.3.2.3 Summary	22
3.4 TASK 3 - FLOW-THROUGH SEGREGATION SYSTEMS AND HANDHELD SCREENING DEVICES	24
3.4.1 <u>Cylinder Flow-Through Segregation System</u>	24
3.4.2 <u>Continuous Flow-Through Segregation System</u>	24
3.4.3 <u>Handheld Screening Devices</u>	28
3.4.3.1 Introduction	28
3.4.3.2 SnO ₂ Vapor Contamination Screening Device	28
3.4.3.3 Liquid Conductivity Device	29
3.4.3.4 Viscosity and IR Devices	29
3.5 TASK 4 - FEASIBILITY OF AN ECONOMICAL WASTE OIL MANAGEMENT PROGRAM	29
3.5.1 <u>Introduction</u>	29
3.5.2 <u>Waste Oil Reprocessors and Recyclers</u>	31
3.5.3 <u>Government Regulations</u>	32
3.5.3.1 Introduction	32
3.5.3.2 Standards for the Management of Used Oil (40 CFR 279)	33
3.5.3.3 Oil Pollution Prevention (40 CFR 112)	34
3.5.3.4 Liability Limits for Small Onshore Storage Facilities (40 CFR 113)	35
3.5.3.5 Guideline for Federal Procurement of Lubricating Oils Containing Re-refined Oil (40 CFR 252)	35
3.5.3.6 Labeling of Certain Oil (RCRA 2005)	36
3.5.3.7 Guidance for Locating and Operating a Small Test and Collection Facility for Used Turbine Oils	36

TABLE OF CONTENTS (concluded)

<u>SECTION</u>	<u>PAGE</u>
3.6 SUMMARY	38
4 CONCLUSIONS AND RECOMMENDATIONS	39

Accession For	
NIIS GRA&I	<input checked="" type="checkbox"/>
DTIC TAB	<input type="checkbox"/>
Unannounced	<input type="checkbox"/>
Justification	
By _____	
Distribution/Avail _____	
Availability Codes	
Dist	Avail and/or Special
A-	

LIST OF ILLUSTRATIONS

<u>FIGURE</u>		<u>PAGE</u>
1	Photograph and Schematic of Tin Dioxide Sensor (Taken from Figaro Technical Brochure).	6
2	Schematic of Liquid Conductivity Probe.	7
3	Schematic of Cylinder Flow-Through Segregation System.	10
4	Photograph of Continuous Flow-Through Segregation System.	12
5	Flowchart of Cylinder Flow-Through Segregation System.	25
6	Flowchart of Continuous Flow-Through Segregation Device.	27
7	Plot of Portable Conductivity (POCOT) Screening Device Readings (Number of Lights) versus COBRA Readings for Used Aircraft Engine Oils (MIL-L-7808 and MIL-L-23699) Tested by Pratt & Whitney Personnel.	30

LIST OF TABLES

<u>TABLE</u>		<u>PAGE</u>
1	VISCOSITY, DENSITY, AND CONTAMINANT MEASUREMENTS OF USED AIRCRAFT ENGINE OILS OBTAINED FROM MILITARY BASES	14
2	VISCOSITY, DENSITY, AND CONTAMINANT MEASUREMENTS OF USED AIRCRAFT ENGINE OILS OBTAINED FROM COMMERCIAL SITES	16
3	SENSITIVITIES OF DEVELOPED SENSORS TO DIFFERENT TYPE SOLVENTS, LIQUIDS, AND LUBRICANTS	21
4	SnO ₂ VAPOR SENSOR, CONDUCTIVITY, VISCOSITY AND GAS CHROMATOGRAPH-MASS SPECTROMETRIC CONTAMINATION RATINGS FOR COLLECTED USED AIRCRAFT ENGINE OIL SAMPLES	23

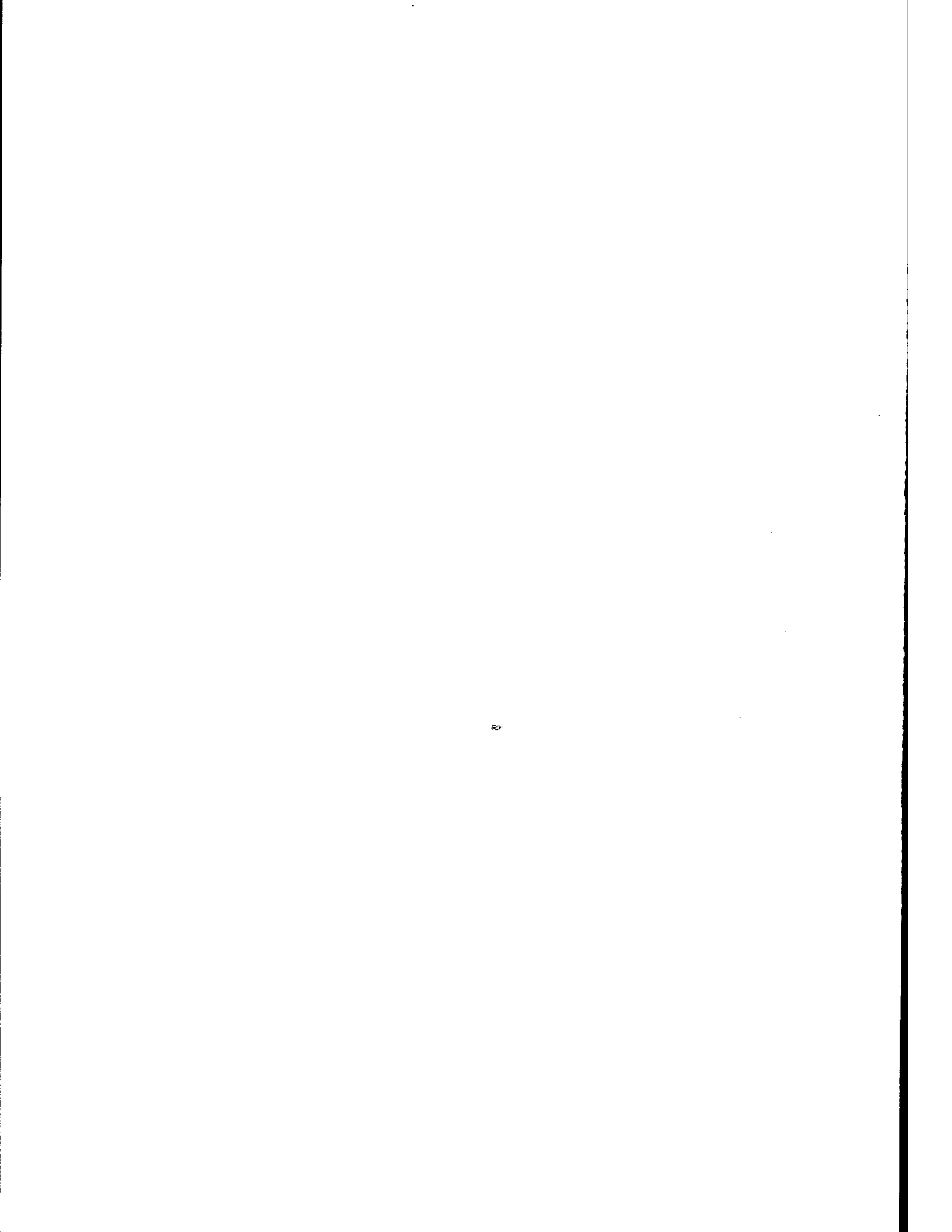

SECTION 1 INTRODUCTION

The Air Force historically has combined used lubricating oils from different sources for recycling and reuse in secondary markets. However, present and future environmental regulations dictate that the Air Force develop waste management programs that segregate the collected used oils and fluids into well-documented stores of known composition. Segregating the collected used oils and fluids will also enable the Air Force to sell the waste oils and fluids to reprocessors increasing the economic and environmental benefits of the developed waste management programs.

Past markets for used synthetic ester lubricants included their use as a plasticizer or heating fuel. However, the fastest growing market for used ester lubricants is their use as reprocessed basestocks in refrigeration compressor oils and other type lubricants. Studies performed for the Air Force have shown that used oils collected at central collection stations can easily be contaminated by personnel improperly disposing of other materials such as fuels, mineral oil lubricants, silicone oils, hydraulic fluids and solvents, nonhalogenated and halogenated. The presence of contaminants in waste oils greatly reduce their value to reclaim/reuse markets. Thus, procedures and techniques were needed to segregate the used oil collection system to ensure that collected materials meet the specifications required for the market chosen for reuse.

Therefore, research was performed by the University of Dayton Research Institute to develop used oil management programs capable of segregating used aircraft engine oils (MIL-L-7808 and MIL-L-23699) from contaminated aircraft engine oils and nonaircraft engine lubricants and fluids. The research described herein was performed to identify and develop sensors capable of screening used aircraft engine oils for contaminants such as halogenated and nonhalogenated solvents, fuels, aqueous solutions, and automotive engine oils. The developed sensors were then incorporated into flow-through, computer-controlled systems to evaluate the sensors' capabilities to detect contaminants and degraded oils in used aircraft engine oils entering waste dumps and 55-gallon drums. Easy to operate handheld devices incorporating the developed sensors were then constructed and evaluated to ensure used aircraft engine oils do not become contaminated during storage. The handheld devices were also evaluated for ease of use and accuracy by commercial waste oil handlers. Markets and environmental requirements for Air Force waste oil management programs for the segregated used aircraft engine oils were also identified during the research described in this report.

SECTION 2

EXPERIMENTAL

2.1 LUBRICATING OILS

2.1.1 Aircraft Turbine Engine Oils

The fresh aircraft turbine engine oils used to calibrate the developed contaminant sensors were MIL-L-7808H and MIL-L-23699C oils (ester based) and were obtained from WL/POSL personnel. The used aircraft turbine engine oils (1-quart to 5-gallon sample size) studied during this program were MIL-L-7808 and MIL-L-23699 type oils obtained directly from aircraft engines and waste oil dumps located at military and commercial maintenance facilities.

2.1.2 Automotive and Diesel Engine Oils

The fresh and used automotive and diesel engine oils (mineral oil based) added as synthetic contaminants to the aircraft turbine engine oils were SG/CD grade oils and were obtained from equipment operators and commercial suppliers.

2.1.3 Hydraulic Fluid

The fresh hydraulic fluids added as synthetic contaminants to the aircraft turbine engine oils were antiwear (zinc dialkyl dithiophosphate), oxidation inhibited (hindered phenol) fluids (mineral oil based) and were obtained from commercial suppliers and equipment operators.

2.2 CHEMICALS

2.2.1 Solvents

The chlorinated and nonchlorinated solvents added as synthetic contaminants to aircraft turbine engine oils were reagent grade and were obtained from Aldrich Chemical Company (Milwaukee, WI).

2.2.2 Acids

The organic and mineral acids added as synthetic contaminants to aircraft turbine engine oils were reagent grade and were obtained from Aldrich Chemical Company (Milwaukee, WI).

2.2.3 Fuels

The fuels added as synthetic contaminants to aircraft turbine engine oils were JP-4 and JP-8 jet engine fuels and No. 2 diesel engine fuels obtained from WL/POSF personnel.

2.3 COMMERCIAL EQUIPMENT

2.3.1 Gas Chromatograph

The gas chromatograph used in the waste oil analysis was a Varian (Woburn, MA) Aerograph Model 2440. This model is equipped with dual injectors and a universal dual detector base which accepts a standard flame ionization detector.

One microliter of sample was injected into a capillary column (HP-1, Hewlett-Packard, San Diego, CA) heated at a rate of 10°C per minute from room temperature to 275°C. The resulting spectra were displayed and printed using a data acquisition system based on an AppleII GS (Cupertino, CA) computer system. The spectra of the used oil samples were analyzed and compared to those of known standards to identify and quantify the contaminants present in the used oil samples.

2.3.2 Gas Chromatograph-Mass Spectrometer

GC/MS analysis was performed using a Hewlett-Packard (San Diego, CA) Model 5890A gas chromatograph with a 5970B mass selective detector. A J&W Scientific (New Brighton, MN) 25-meter (model DB-5) column with a 0.25 micron film thickness was used for separation. The system was ramped from 40°C to 290°C at a rate of 20°C per minute. The mass spectra analysis covered a range of 25 amu to 350 amu.

2.3.3 Infrared Spectrophotometer

The infrared spectrophotometer used to obtain the IR spectra was a Beckman IR-20A (Beckman Instruments, Inc., Fullerton, CA). This model has a spectral range of 400 to 250 cm^{-1} . A Nernst glower is used as the IR source.

The sample is prepared and analyzed as a thin film (neat) between two potassium bromide plates. The resulting spectra are recorded, displayed, and printed using a data acquisition system based on a AppleII GS (Cupertino, CA) computer system. The resulting spectra are compared to spectra of known standards to determine the chemical class of the sample.

2.3.4 Brookfield Viscometer

The Brookfield (Stoughton, MA) LVDV-I+ viscometer uses the principle of rotational viscometry. The viscosity is measured by sensing the torque required to rotate a spindle at constant speed while immersed in a sample fluid. The torque is proportional to the viscous drag on the spindle and thus to the viscosity of the fluid.

The test is performed by placing the sample into a test container that allows the spindle to be immersed in the fluid and to rotate freely. The digital readout displays the values for the viscosity in centipoise, spindle speed in RPM percent scale, and spindle type used.

2.3.5 Visgage Viscometer

The Visgage Model 38 (Louis C. Eitzen Company of Glenwood Springs, Colorado) is a portable viscosity comparator that quickly checks oil viscosity. The viscosity measurement is taken at room temperature and reads in centistokes at 40°C and requires no calculations or conversions.

The Visgage measurement is based on the principle of comparing the viscosity of the sample in one tube to an oil of known viscosity in a second tube. The standard oil of known viscosity is sealed into one tube at the factory. The oil sample is drawn into the second, empty tube via a plunger. When the sample tube is full, the testing process begins by tilting the Visgage to an angle of 30 to 45° causing two steel spheres inside the test tubes to descend. As the leading sphere approaches the standard measurement line, the unit is gradually returned to the horizontal position until the leading sphere aligns with the standard measurement line. At this point, the position of the second sphere is read to obtain the viscosity of the oil sample.

2.3.6 Kinematic Viscosity Tube

The calibrated viscosity tubes (Cannon-Fenske Type, Fisher Scientific, Pittsburgh, PA) were used according to a standard kinematic viscosity measurement method (ASTM D445) in which a 7 mL of liquid is drawn into the viscosity tube. The viscosity tube is placed into a 40°C ± 0.1 constant temperature bath. The time required for a column of oil in the viscosity tube to descend a preset distance is converted into viscosity (centistokes) using the tube conversion constant.

2.4 LAB CONSTRUCTED EQUIPMENT

2.4.1 Vapor Contaminant Sensor

The vapor contaminant sensor utilizes a Figaro TGS823 (Wilmette, IL) tin dioxide semiconductor gas sensor (Figure 1). While this particular sensor is designed for the detection of organic solvent vapors, it was also found to be suitable for the detection of chlorinated vapors. When required for higher selectivity to chlorinated compounds, a Figaro TGS 830 (Wilmette, IL) tin dioxide sensor was used in place of the TGS 823 sensor. The sensor was situated at least 3 inches above the used oil surface in a closed container to ensure the sensor did not become contaminated through direct contact with the liquid.

The sensing element is a tin dioxide layer on an alumina tube that contains two gold electrodes. As the vapor concentration increases, the electrical resistance between the electrodes decreases. This decrease in resistance results in a voltage for output to a digital display, strip chart recorder, or data taker/computer system.

2.4.2 Conductivity Sensor

The conductivity sensor was produced from two 0.040 diameter steel wires encased in teflon heat shrink tubing. The two parallel wires extend approximately 1 inch past the end of the teflon heat shrink tubing and are spaced approximately 0.1 inch apart (Figure 2). The conductivity measurements are made between the two exposed metal wires which are immersed in the used oil. The conductivity measurements are performed by applying a triangular waveform ($\pm 12V$) at a rate of 1V/second to the conductivity probe. The resulting current is rectified and converted to a voltage for output to a digital display, strip chart recorder, or a data taker/computer system.

2.4.3 Infrared Sensor

The infrared sensors were constructed using a lab constructed device based on three components: an IR source, a detector, and a long wave pass filter.

The IR source (Model number PE1ZC1WLA) was a Nichrome wire obtained from Buck Scientific (East Norwalk, CT). A thermopile (Model 2M) detector manufactured by Dexter Research (Dexter, MI) was used to detect the light transmitted by the oil sample at a set wavelength through a potassium bromide window. An infrared filter (Model number RL-3500-F) made by Corion Corporation (Holliston, MA) was used to monitor the carbonyl ($C=O$) (1780 to 1690 cm^{-1}) band region of the infrared spectrum. The voltage output of the detector

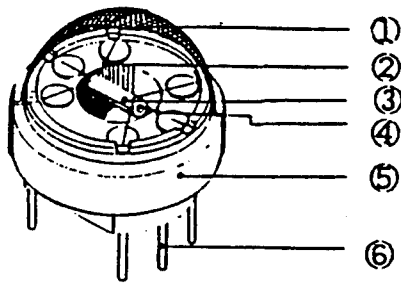
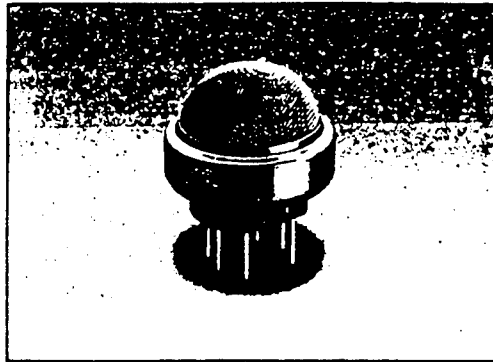

- ① Flame arrester : 100 mesh stainless steel guaze (double)
- ② Lead wire : Gold alloy
- ③ Sensing element : Tin dioxide (SnO_2) ceramic
- ④ Heater coil : Nickel alloy
- ⑤ Base : Alumina ceramic (A type), Nylon 66 (B type)
- ⑥ Pins : Cobalt (A type), Nickel (B type)

Dimension (mm)

Figure 1. Photograph and Schematic of Tin Dioxide Sensor
(Taken from Figaro Technical Brochure).

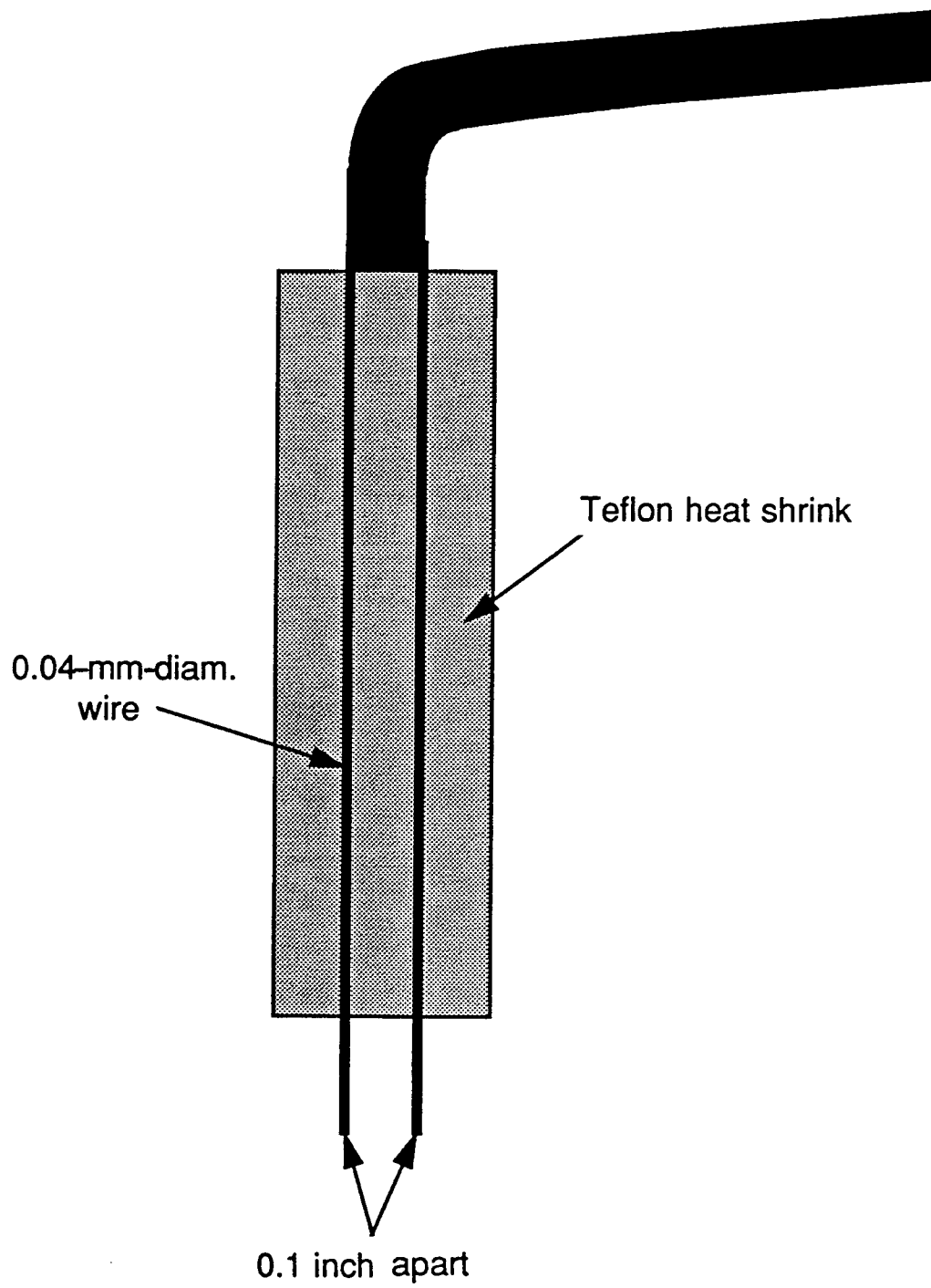

Figure 2. Schematic of Liquid Conductivity Probe.

was converted to a digital display, strip chart recorder, or data logger for recording test results.

The principle involved in the IR system is that ester oils could be distinguished from hydrocarbon and silicone oils by detecting the carbonyl absorption band that is characteristic of the ester oils and is absent in hydrocarbon and silicone oils. A drop of oil is placed on the polyethylene film window of a disposable IR sample card (3M Corporation, St. Paul, MN). The sample card is inserted into the slot of the IR sensor to measure the transmittance of the 1800- to 1650-cm⁻¹ wavelength region. A known ester with a transmittance level of 10% (strong C=O absorbance) was used for comparison studies with contaminants and nonaircraft engine oils.

2.5 HANDHELD SCREENING DEVICES

2.5.1 Vapor Contaminant Screening Device

The handheld vapor contaminant screening device is powered by a battery pack (consisting of eight, 1.5-V nickel-cadmium batteries) which requires recharging (standard ac outlet) after 8 hours of continuous operation. The generated voltage of the tin dioxide sensor is outputted to a 10-position LED bar graph display. The units were calibrated so that the tenth LED indicated 1,000 ppm of chlorine (carbon tetrachloride source of volatile chlorine) was detected in the vapor phase. The first LED was calibrated to indicate the chlorine level in the vapor phase was below the detection level of the tin dioxide sensor.

The battery pack, circuitry, LED bar graph display, and connection for the tin dioxide sensor were encased in an electronics grade metal box (Tracewell, Westerville, OH) to construct the handheld devices. Two versions of the handheld devices were constructed. In one version, the tin dioxide sensor was connected directly to the bottom surface of the metal box. In the second version, the tin dioxide sensor was built in a handheld probe which was connected by a 1-foot, flexible cable to the bottom surface of the metal box.

2.5.2 Liquid Conductivity Sensor

The handheld liquid conductivity device is powered by a battery pack (consisting of eight, 1.5-V nickel-cadmium batteries) which requires recharging (standard ac outlet) after 8 hours of continuous operation. The generated voltage of the conductivity sensor is outputted to a 10-position LED bar graph display. The units were calibrated so that the tenth LED indicated a conductivity level equal to used sample No. 2 from commercial airline No. 2. The first LED was calibrated to indicate the conductivity level was slightly higher than fresh lubricant.

The battery pack, circuitry, LED bar graph display, and connection for the 1-foot, flexible cable of the conductivity sensor were encased in an electronic grade metal box (Tracewell, Westerville, OH) to construct the handheld devices.

2.6 FLOW-THROUGH SEGREGATION SYSTEM

2.6.1 Cylinder Flow Through

As shown in Figure 3, the unit consists of a laptop computer, the control box, the 5-gallon testing tank, electronic and manual valves, rejection container, and the 55-gallon collection drum (containing a level sensor).

The testing tank (Figure 3) is an aluminum, 5-gallon tank (Worthington Cylinder, Columbus, Ohio) which has been modified to accommodate the necessary plumbing for the sensors and sample entrance and exit ports. The vapor sensor (Figure 1) is housed in a cap assembly in the head space at the top of the tank to protect the sensor from liquid contact (Figure 3). The conductivity probe (Figure 2) is inserted into the tank through an opening in the top of the cylinder (Figure 3). Used oil samples are poured through the large entrance port in the top of the testing tank. Once the entire sample has been poured in and the lid closed, the testing process begins.

The control box in Figure 3 powers the sensors and contains a data taker (Model 50 from Science/Electronics, Dayton, OH) which monitors the outputs of the sensors. The collected data are sent to the laptop computer (Tandy Model 3800HP computer, Radio Shack, Fort Worth, TX) where it is averaged and compared to predetermined rejection limits. The computer instructs the unit to either accept or reject the sample based on the collected information.

Plumbing fixtures at the bottom of the testing tank have been configured to route the sample to the appropriate collection container. If the sample is accepted as clean, the electronic valve (Model SV225 Omega, Stanford, CT) will open (Figure 3) allowing the sample to flow into the collection drum. When a contaminated sample is rejected, a buzzer sounds and the electronic valve remains closed (Figure 3) requiring the operator to manually drain the tank into a collection container to be stored with other contaminated samples. The electronically controlled solenoid valve operates in a normally closed position and opens only when a sample has been accepted by the unit.

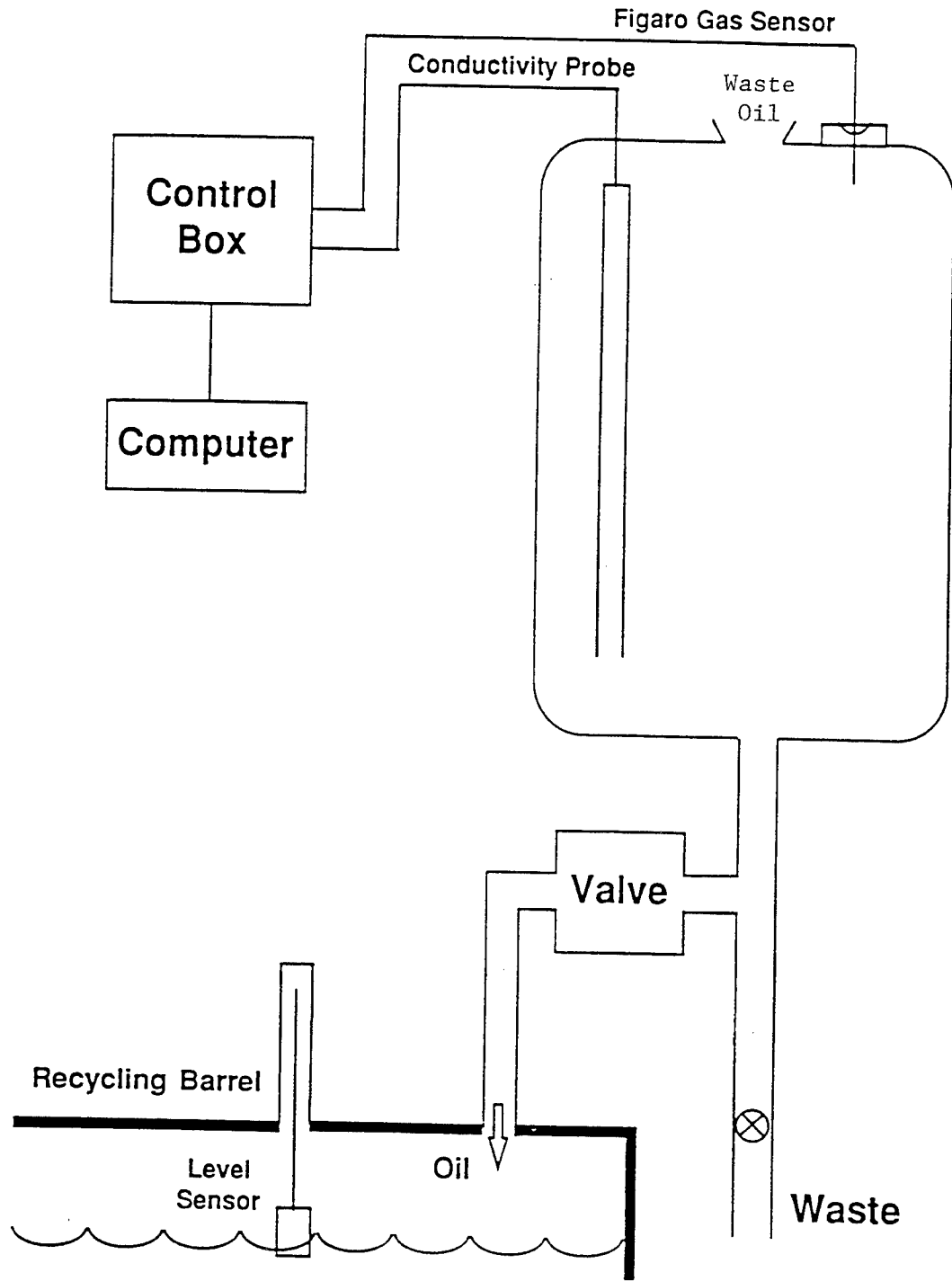

Figure 3. Schematic of Cylinder Flow-Through Segregation System.

A drum level sensor (Model 606000, Global, Port Washington, NY) has been installed into the 55-gallon collection drum (Figure 3). When the drum is full, the computer will not permit testing to take place until the drum is replaced. This will prevent overfilling of the collection drum.

2.6.2 Continuous Flow Through

As shown in Figure 4, the unit consists of a programmable microprocessor, a S-shaped brass pipe (2-inch-diameter) fitted with the tin dioxide vapor contaminant and liquid conductivity sensors and a solenoid valve to control access to the waste dump. A rotating spindle viscometer (Brookfield Model LVD-I+, Stoughton, MA) can be inserted as indicated in Figure 4 to segregate oils by viscosity grade. A (Optrex, DMC-16117N, Japan) display is used to prompt the user and is capable of displaying sensor readings, contaminant levels (pass/fail) and types of contaminant (vapor, liquid, viscosity, etc.).

The electronically controlled valve is only closed when contamination is detected by the vapor, liquid, viscosity, etc. sensors. The open valve allows the vapor sensor to monitor the vapors above the waste dump during storage. Removable plugs are situated at the low point of the S-shaped brass piping to expedite cleanup after contamination.

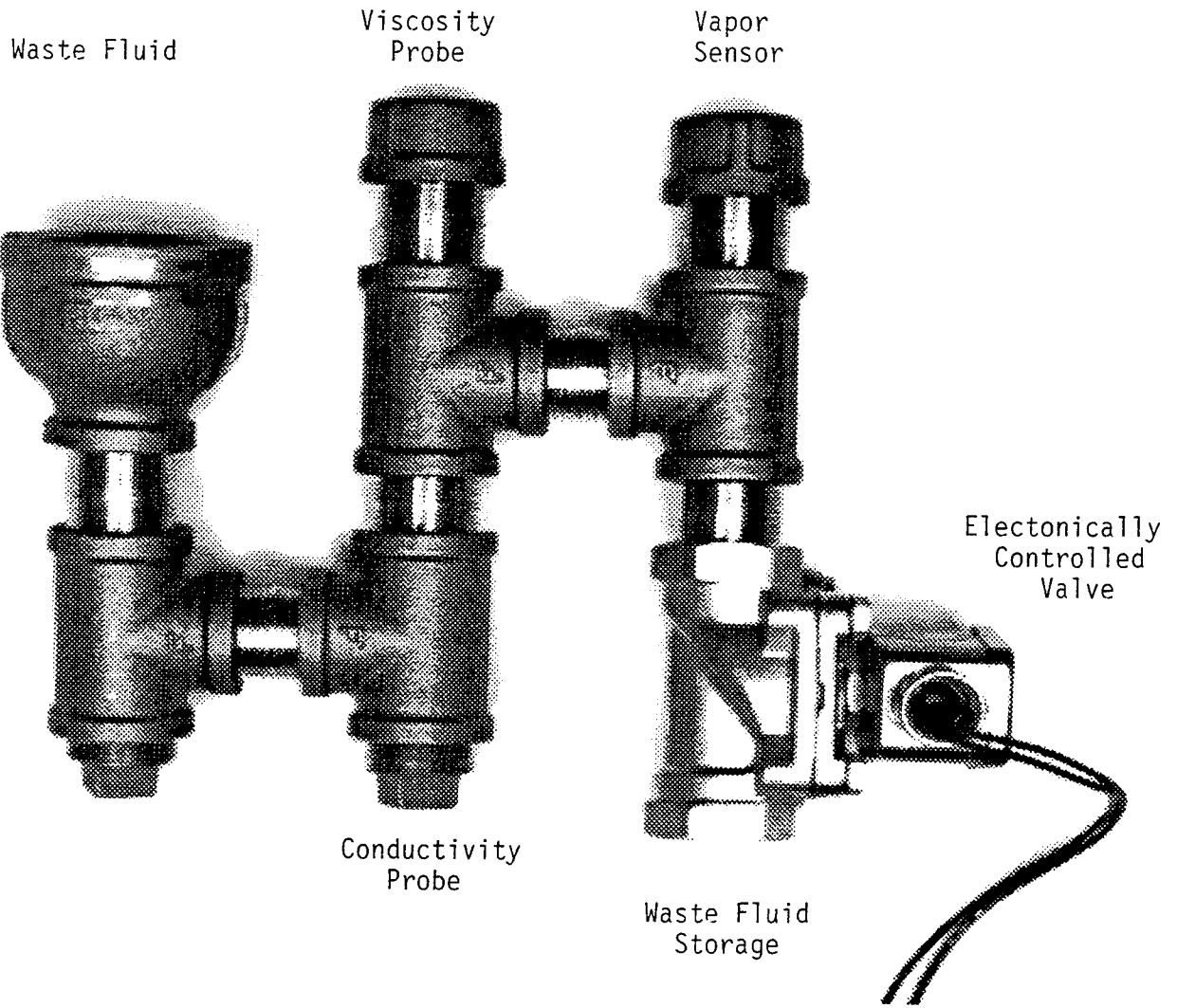

Figure 4. Photograph of Continuous Flow-Through Segregation System.

SECTION 3 RESULTS AND DISCUSSION

3.1 INTRODUCTION

The research was performed in four major tasks. In the first task, used aircraft engine oil samples were obtained from waste dumps, from 55-gallon storage drums prior to disposal, directly from aircraft engines, and from used oil dumps after spectrometric analysis for wear metals. The used aircraft engine oil samples were obtained from both Air Force and commercial maintenance facilities. The used aircraft engine oil samples were then analyzed by gas chromatography-mass spectrometry (GC-MS) to identify and quantify the contaminants present in the obtained used oil samples. Task 2 was performed simultaneously with Task 1 and was performed to identify and develop analytical techniques capable of detecting the various contaminants detected by GC-MS analyses of the used aircraft engine oil samples. In Task 3 the selected techniques were incorporated into flow-through systems and handheld devices capable of segregating used aircraft engine oils from contaminated aircraft engine oils and nonaircraft engine oils. Commercial maintenance facilities and waste oil recyclers were supplied with handheld devices to evaluate the ease of operation and accuracy of the prototype devices. In the final task, markets and environmental requirements for Air Force waste oil management programs were identified and evaluated.

3.2 TASK 1 - USED AIRCRAFT ENGINE OILS

3.2.1 Military Base Used Oil Samples

During the program, used oil samples (1 quart to 5 gallon) were obtained from the waste dumps and directly from aircraft engines located at Eglin, Edwards, Kelly, and Wright-Patterson Air Force bases and Fort Smith Army base. The used oil samples were primarily MIL-L-7808 type oils. The used oil samples were analyzed as received for contaminants by GC analysis (detected contaminants identified by GC-MS analysis) and were characterized by viscosity (40°C) and density measurements. Infrared spectrophotometric analyses were also performed to confirm the chemical class (ester) of the used oil samples and to screen for non-volatile contaminants. The viscosity, density, and contaminant (GC-MS) measurements for the used oil samples are listed in Table 1.

TABLE 1

VISCOSITY, DENSITY, AND CONTAMINANT MEASUREMENTS OF USED
AIRCRAFT ENGINE OILS OBTAINED FROM MILITARY BASES

<u>Air Force Base</u>	<u>Sample No.</u>	<u>Source</u>	<u>Viscosity (cs)</u>	<u>Density (g/cc)</u>	<u>Contaminant</u>
Edwards AFB	1	Waste Dump	11.8	0.943	Jet Fuel
Eglin AFB	1	Waste Dump	12.2	0.962	Trichloroethane (0.3%)
Kelly AFB	1	Engine	12.3	0.947	Not Detected
	2	Waste Dump	3.4	0.872	Jet Fuel
Fort Smith	1	Spectrometer	15.4	0.952	Trichloroethane
					Limonene Jet Fuel
Wright-Patterson	1	Engine	17.6	0.967	Not Detected
	2	Engine	16.8	-	Not Detected
	3	Waste Dump	3.1	-	Jet Fuel

The results in Table 1 indicate that the major contaminants in the used aircraft engine oils obtained from the waste dumps are trichloroethane and jet fuel. The limonene detected in the Fort Smith sample is most likely the waste generated by the cleaning process used to remove oil from the sample analysis chamber of the spectrometer. The results in Table 1 also indicate that the used aircraft engine oils obtained directly from engines do not contain detectable levels of contaminants.

The infrared spectra of the Eglin AFB and Fort Smith used oil samples indicate that the infrared spectrophotometric technique is unable to detect contamination levels below 1%. Current regulations (defining hazardous waste) require contaminant detection capabilities of below 0.1% (1000 ppm) for chlorinated solvents. Consequently, the infrared spectrophotometric technique was determined to be well suited for identifying the chemical class of the used oil (ester, hydrocarbon, etc.) and to be poorly suited for contamination detection.

Therefore, the results in Table 1 indicate that the used aircraft engine oils in the waste dumps of Air Force and other U.S. Military bases may be contaminated and that the contamination is occurring at the dump site not during use in the engine.

3.2.2 Commercial Site Used Oil Samples

During the program, used oil samples (5 gallon) were obtained from one waste dump and directly from numerous aircraft engines located at commercial airlines, express freight, and hospital helicopter facilities. The used oil samples were primarily MIL-L-23699 type oils. The used oil samples were analyzed as received for contaminants by GC analysis (detected contaminants identified by GC-MS analysis) and were characterized by viscosity (40°C) and density measurements. The viscosity, density, and contaminant (GC-MS) measurements for the used oil samples are listed in Table 2.

The results in Table 2 indicate that the used aircraft engine oils obtained from the aircraft engines are not contaminated. Only the waste dump sample (number 1 from commercial airline 2) contained a contaminant identified as jet fuel. However, sample number 2 from commercial airline 2 obtained directly from an abnormally operating engine has a higher than normal viscosity value indicating severe oil degradation.

TABLE 2

VISCOSITY, DENSITY, AND CONTAMINANT MEASUREMENTS OF USED
AIRCRAFT ENGINE OILS OBTAINED FROM COMMERCIAL SITES

<u>Site</u>	<u>Sample No.</u>	<u>Source</u>	<u>Viscosity (cs)</u>	<u>Density (g/cc)</u>	<u>Contaminant</u>
Commercial Airline 1	1	Engine	27.1	0.962	Not Detected
	2	Engine	24.3	0.967	Not Detected
	3	Engine	25.3	0.965	Not Detected
	4	Engine	24.8	0.964	Not Detected
Commercial Airline 2	1	Waste Dump	23.6	0.970	Jet Fuel (3%)
	2	Engine	48.8	0.998	Not Detected
	3	Engine	26.9	0.993	Not Detected
	4	Engine	29.8	0.993	Not Detected
	5	Engine	35.9	0.988	Not Detected
	6	Engine	31.4	0.989	Not Detected
Express Freight	1	Engine	23.9	0.996	Not Detected
Hospital Helicopter	1	Engine	25.5	0.996	Not Detected

Therefore, the results in Table 2 indicate that the used aircraft engine oils in the commercial waste dumps may be contaminated and that used oils may become less suitable (less economical) for recycling due to degradation caused by severe operating conditions.

3.3 TASK 2 - CONTAMINATION SENSORS

3.3.1 Identification of Analytical Techniques

3.3.1.1 Introduction

The analytical results in Tables 1 and 2 indicate that sensors designed for screening used aircraft engine oils for contamination and degradation must be capable of detecting a wide variety of organic solvents and must be able to detect degradation species produced by abnormally operating engines. Other sources of possible contamination include used automotive engine oils, hydraulic fluids, and other nonaircraft engine fluids.

In addition to contamination detection, the following criteria were used in selecting the analytical techniques to be developed into contamination sensors:

- Easy and inexpensive to operate
- Inexpensive to construct or purchase
- Incorporation into flow-through systems
- Miniaturization into handheld devices
- Reliable, rugged, and rapid
- Detects a wide variety of contaminants

Three types of sensors (vapor contaminants, liquid conductivity, and viscosity) were identified during this research program for development into used oil screening devices. A fourth type of sensor, a variable, wavelength infrared sensor was also developed for determining the used oil's chemical class, ester versus hydrocarbon, silicone, phosphate, etc.

3.3.1.2 Vapor Contaminant Sensors

Computer-aided literature searches and contacts with equipment manufacturers identified the following types of sensor/detectors:

- Tin dioxide (SnO_2) vapor sensor
- Portable gas chromatograph with different detectors

- Surface acoustic wavelength (SAW) device
- Halogenated vapor sensor

Of the identified sensor/detectors, the SnO₂ vapor sensors were judged the best suited for development into vapor contaminant sensors. The SnO₂ vapor sensors have been used for decades in storage rooms to sense the buildup of organic vapors and meet all the listed criteria.

The portable gas chromatographs would be useful as a secondary analytical technique to study, and possibly identify, the volatile contaminants detected by the oil screening device. However, the portable gas chromatographs are not suitable for incorporation into an oil segregation system and are more expensive to operate and purchase than SnO₂ sensors. The SAW device and halogenated vapor sensors are specific to certain classes of vapors, and consequently, would not detect a wide range of volatile contaminants.

Therefore, the vapor contaminant sensor was constructed from the SnO₂ sensors as described in the Experimental Section (paragraph 2.4.1) for evaluation with solvents and other volatile contaminants present in used aircraft engine oils.

3.3.1.3 Liquid Conductivity Sensors

Computer-aided literature searches and contacts with equipment manufacturers identified several electrical properties of oils which could be used to evaluate the contamination and degradation levels of used oil samples. Of the identified electrical properties (conductivity, dielectric constant and loss, capacitance, etc.), the sensors used by conductivity measurements were judged the best suited for development into liquid contamination and degradation sensors. The conductivity measurements are made between two closely spaced, parallel wires of equal length (Figure 2). If necessary, simple modifications (increasing wire length, decreasing the gap between the electrodes) could be made to increase the sensitivity of the conductivity sensors to lower concentrations of thermal degradation and contamination in used aircraft engine oils.

The sensors used by dielectric (concentric circles of metal wires) and capacitance (two closely spaced metal plates) measurements were judged to be less rugged, less reliable, and harder to modify for incorporation into the flow-through systems and handheld devices than the conductivity sensor.

Therefore, a liquid contamination sensor was constructed from the conductivity sensors as described in the Experimental Section (paragraph 2.4.2) for evaluation with solvents and other liquid contaminants present in used aircraft engine oils.

3.3.1.4 Viscosity Sensors

Computer-aided literature searches and contacts with equipment manufacturers identified the following types of viscosity measuring devices:

- Rotating spindle
- Vibrating reed
- Vibrating quartz crystal
- Flow through a calibrated orifice
- Falling ball

Of the identified techniques, the rotating spindle viscometer was judged to be the best suited for incorporation into flow-through segregation system for used aircraft engine oils. A handheld falling ball viscometer was judged to be the best suited for limiting the number of contaminated oils entering the flow-through segregation system.

The vibrating reed viscometer was judged to be too expensive and impractical for incorporation into the flow-through device. The vibrating quartz crystal viscometer is still in development, is fragile and susceptible to contamination, and will require extensive electronics modification for incorporation into a flow-through segregation system. Since sample volumes of 1 quart to 5 gallons possibly containing high levels of particle contamination will be monitored during use, the viscometers based on liquid flow through a calibrated orifice (require a specified volume of liquid without particle contamination) were judged impractical for incorporation into flow-through segregation systems.

Therefore, the handheld fall ball viscometer (paragraph 2.3.5) and rotating spindle viscometer (paragraph 2.3.4) were evaluated with solvents and other contaminants present in used aircraft engine oils.

3.3.1.5 Variable Wavelength Infrared Sensors

Due to the high cost and lack of ruggedness of commercial infrared (IR) spectrophotometers (grating IR or Fourier Transform IR), a handheld IR sensor was constructed. The IR analyses of the used oil samples collected from the military bases (Table 1) and commercial sites (Table 2) demonstrated that IR spectrophotometry has very limited potential for development into a contamination detector. Therefore, the handheld IR sensor was developed for chemical class verification (ester for aircraft engine oils) of used oils prior to entering the flow-through segregation system.

As described in the Experimental Section (paragraph 2.4.3), the handheld IR sensor uses interchangeable optical filters to select the wavelength to be monitored by the detector. In the case of aircraft engine oils, the filter allows the wavelength region of 1400 to 2600 cm^{-1} to pass through to the detector. Esters used as basestocks in aircraft engine oils absorb the IR region of 1610 - 1710 cm^{-1} [carbonyl (C=O) group in the ester molecule] reducing the output of the IR detector to 0%. Other lubricants such as automotive oils and fluids, hydraulic fluids, etc. do not absorb in the IR region of 1400 to 1650 cm^{-1} increasing the output of the IR detector to 100%. Consequently, used oils producing very low readings (below 5%) are considered uncontaminated aircraft engine oils.

Therefore, the handheld IR sensor was evaluated with solvents and various types of lubricating oils and fluids to determine the accuracy of the sensor chemical classifications.

3.3.2 Evaluation of Selected Analytical Techniques

3.3.2.1 Solvents and Fluids

To initially evaluate the contamination detection, degradation detection, and chemical classification capabilities of the selected analytical techniques, various types of solvents and fluids were analyzed with the SnO_2 vapor sensor, conductivity liquid contamination sensor, rotating spindle viscometer, and variable wavelength IR sensor. The sensitivities of the sensors to the solvents and fluids were rated as high (H), medium (M), low (L) and not detected (ND) in Table 3.

TABLE 3

SENSITIVITIES OF DEVELOPED SENSORS TO DIFFERENT
TYPE SOLVENTS, LIQUIDS, AND LUBRICANTS

Compound *	Sensor Type			
	SnO ₂	Conductivity	Viscosity	IR
MIL-L-23699 Oil	ND	ND	H	ND
Automotive Oil	ND	H	M	M
Used Automotive Oil	H	M	M	ND
Mineral Oil	ND	ND	M	H
Chlorinated Oil	ND	H	M	H
JP-8 Jet Fuel	M	ND	H	H
JP-4 Jet Fuel	H	ND	H	H
Gasoline	H	ND	H	H
Chlorinated Solvents	H	H	H	H
Acetone	H	L	H	ND
Toluene	H	ND	H	H
Limonene	H	ND	H	H
Nonchlorinated Solvents	H	ND	H	H
Organic Acids	ND	H	H	ND
Mineral Acids	ND	H	H	H
Degraded MIL-L-23699 Oil **	ND	H	H	ND
MIL-L-7808 Oil				
+1% Trichloroethane	H	H	ND	ND
+0.1% Trochloroethane	H	ND	ND	ND
+1% JP-4 Fuel	H	ND	ND	ND
+5% JP-8 Fuel	L	ND	ND	ND
+1% Acetone	H	ND	ND	ND
+5% Mineral Oil	ND	ND	ND	ND
+5% Automotive Oil	ND	L	ND	ND
+1% Chlorinated Oil	ND	M	ND	ND
+1% Organic Acid	ND	M	ND	ND
+1% Mineral Acid	ND	H	ND	ND

H - High Sensitivity

M - Medium Sensitivity

L - Low Sensitivity

ND - Not Detected

* Baseline Compound was MIL-L-7808

** Sample No. 2 from commercial airline No. 2 (Table 2)

The results in Table 3 indicate that the SnO₂ vapor contaminant sensor is very sensitive to a wide range of solvents and fluids and is sensitive to below 0.1% (1000 ppm) contamination levels of chlorinated solvents. The contamination level of 1000 ppm is critical since oils containing above 0.1% chlorinated solvents are considered hazardous waste greatly increasing disposal costs.

The results in Table 3 indicate that the conductivity sensor is sensitive to new and used automotive engine oils, chlorinated solvents and oils, acids, and degraded used aircraft engine oils at contamination levels below 5%.

3.3.2.2 Used Aircraft Engine Oils

To further evaluate the potential of the developed sensors for detecting low levels of contamination and degradation, the used oils obtained from the military bases (Table 1) and commercial sites (Table 2) were analyzed with the SnO₂ vapor contaminant sensor, liquid conductivity sensor, and rotating spindle viscometer. Previous results in Tables 1 and 2 indicate that the IR sensors are incapable of detecting the contaminants present in the collected used oils. The contaminant ratings (pass/fail) of the SnO₂ vapor contamination, liquid conductivity, and viscosity analyses as well as the original GC/MS analyses (Table 1) are listed in Table 4 for the collected used oils.

The results in Table 4 indicate that the SnO₂ vapor contamination sensor is extremely effective, i.e., vapor contamination ratings by the GC/MS and SnO₂ sensors are identical. The viscosity contamination ratings are only sensitive to the used oil samples with high levels of contamination. The viscosity and conductivity measurements detected the degraded oil (Commercial airline 2 sample 2 in Tables 2 and 4) which was not detected by the SnO₂ and GC/MS analyses.

3.3.2.3 Summary

The results in Tables 3 and 4 indicate that the combination of the SnO₂ vapor contaminant sensor with the liquid conductivity sensor has a strong potential for development into effective handheld and flow-through segregation devices. The IR and viscosity sensors have potential for development into prescreening tests designed to classify the chemical type and viscosity grade, respectively, of the submitted fluid prior to entering the flow-through segregation system.

3.4 TASK 3 - FLOW-THROUGH SEGREGATION SYSTEMS AND HANDHELD SCREENING DEVICES

3.4.1 Cylinder Flow-Through Segregation System

To evaluate the concept of a flow-through segregation system for used aircraft engine oils, the SnO₂ vapor contaminant and liquid conductivity sensors were incorporated into a modified 5-gallon aluminum cylinder as shown in Figure 3. The cylinder was not suitable for incorporation of a rotating spindle viscometer due to the distance between the top (spindle inserted through top) and bottom (thin oil layer in small samples) surfaces of the cylinder. A laptop computer monitors the outputs of the contamination sensors and waste oil level sensor and controls the actions of the solenoid valve in Figure 3. A flowchart of the operation cycle of the flow-through system is depicted in Figure 5.

If the used oil poured into the cylinder contains undetectable levels of contaminants and degradation, the computer signals the solenoid valve to open allowing the oil to drain into the waste drum. If the sensors detect contamination or degradation, the computer sounds a buzzer and signals the solenoid valve to remain closed. The contaminated or degraded used oil must be drained by hand into a second waste container (Figure 3) for appropriate disposal.

Numerous evaluations with used oils containing differing levels of contamination proved that the concept of a flow-through segregation system was possible. The sensors sounded the buzzer and closed the solenoid valve for samples with unacceptable levels of contamination or degradation listed in Tables 1 and 2. For used oils containing high levels of chlorinated solvent (Tables 1 and 2), the buzzer sounded when the first portion of the oil entered the cylinder. The used oil samples in Tables 1 and 2 without contamination or degradation were allowed to pass into the waste drum through the opened solenoid valve.

3.4.2 Continuous Flow-Through Segregation System

Although the cylinder flow-through segregation device accurately detected and segregated the contaminated and degraded used oils, the segregation device was determined to be poorly suited for routine use for the following reasons:

- Used oil limited to 5 gallons per testing cycle
- Extensive cylinder cleanout required after contaminated oil detected

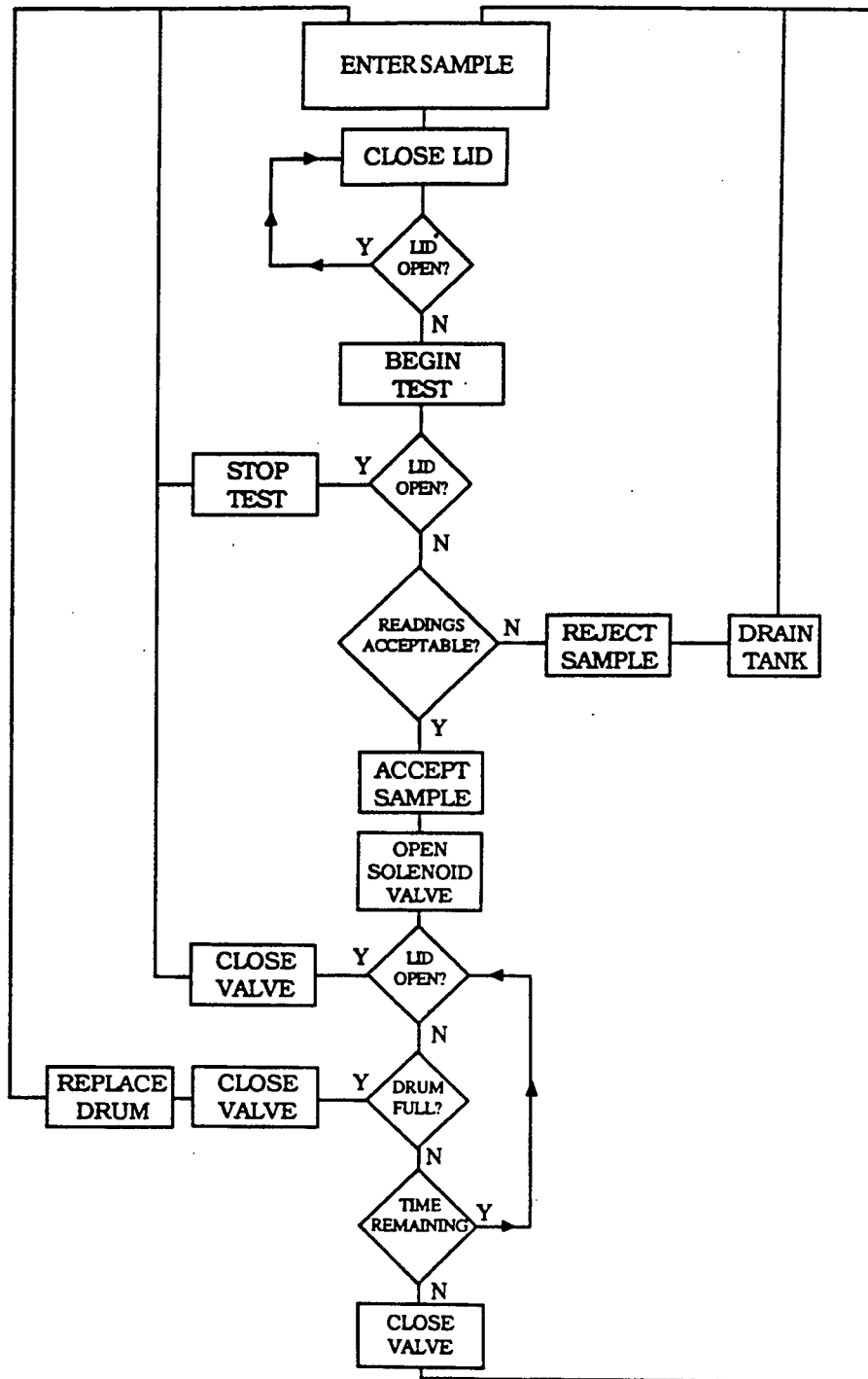

Figure 5. Flowchart of Cylinder Flow-Through Segregation System.

- Laptop computer increases cost of segregation system
- Cylinder drain rate of less than 0.2 gallon/minute
- Sensors do not monitor dump contamination
- Viscometer incorporation into cylinder impractical

Therefore, the continuous flow-through segregation device shown in Figure 4 was designed and constructed to correct the deficiencies of the cylinder flow-through system.

The continuous flow-through segregation device in Figure 4 was constructed from 2-inch brass piping (size of piping dependent on required drainage rate) fitted with the SnO₂ vapor contaminant and liquid conductivity sensors (fitting for viscometer also available for segregating used oils by viscosity class) and a solenoid valve to control access to the waste dump. The contaminant sensors, solenoid valve, waste dump level sensor, and contamination buzzer are monitored and activated by a programmable microprocessor in place of the laptop computer in Figure 3. A display is used to prompt the user, display sensor readings, output contaminant level (pass/fail), and type of failure (vapor, liquid, viscosity, etc.). The electronically controlled valve is only closed when contamination is detected by the vapor or liquid sensors. Since the valve is open when not in use, the vapor sensor continuously monitors the collected waste oil during storage for contamination through unmonitored ports. The piping contains removable plugs to allow draining of contaminated used oil and to decrease the time and effort required to clean the system after contamination. The flowchart of the continuous flow-through system is depicted in Figure 6.

Limited evaluations of the continuous flow-through segregation system have determined that the microprocessor is able to detect contamination and close the solenoid valve before the contaminated oil enters the waste dump at flow rate of up to 2 gal/minute.

Therefore, the initial results indicate that a continuous flow-through segregation system with a design similar to Figure 4 can be constructed which would be economical and well suited for routine use by the Air Force bases to segregate used aircraft engine oils entering waste oil dumps.

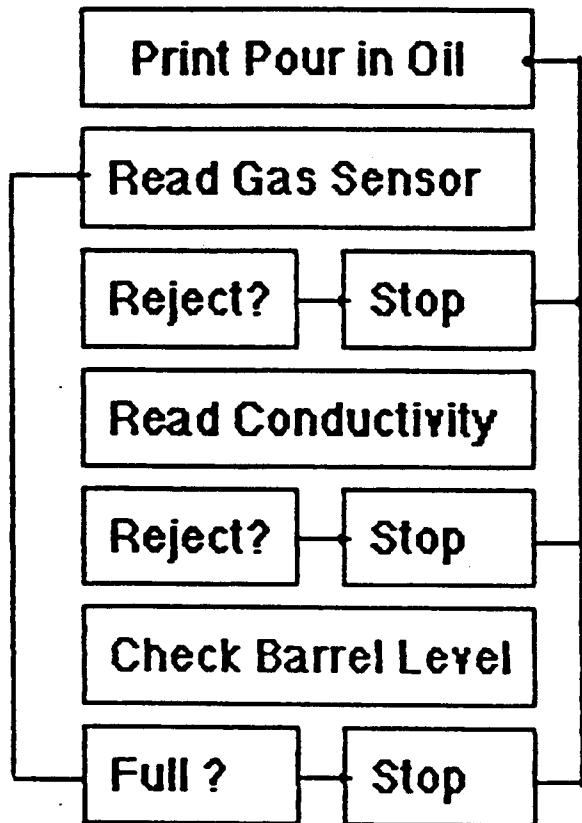

Figure 6. Flowchart of Continuous Flow-Through Segregation Device.

3.4.3 Handheld Screening Devices

3.4.3.1 Introduction

In addition to the flow-through segregation system, handheld devices are needed to screen incoming waste oils for contamination, degradation, chemical type, and viscosity to reduce contamination, and subsequent cleanups, of the flow-through segregation system. The handheld screening devices are also needed to allow used oil reclaimers to verify the waste oils are free of contamination prior to transportation to their facilities. Handheld screening devices based on the SnO₂, conductivity, and IR sensors were developed and evaluated. A commercially available falling ball viscometer was also evaluated.

3.4.3.2 SnO₂ Vapor Contamination Screening Device

The handheld SnO₂ vapor contamination screening device was developed from the SnO₂ sensor (Figure 1). The SnO₂ sensor (high sensitivity to chlorinated vapors) and 10 light LED display were encased in a small metal box and powered by a rechargeable battery pack (approximately 8 hours between charges). The device was calibrated with carbon tetrachloride so that the tenth light represented 1000 ppm chlorine.

Two versions of the screening device were developed and constructed. The first version had the SnO₂ sensor attached directly to the lower surface of the metal box. The first version was designed to allow the device to be placed on top of a 55-gallon drum with the SnO₂ sensor inside the opened bung hole of the drum. The first version was sent to Noble Oil Company (Stanford, NC) for field testing. Personnel from Noble Oil Company obtained good correlation between the results of the handheld SnO₂ screening device with the current wet chemical test (15 minutes test time - color comparator for chlorine content) for chlorinated contamination for collected waste oils. Approximately 50 drums were tested by Noble Oil personnel.

Upon recommendation of the Noble Oil personnel, a second version of the vapor contamination screening device was designed and constructed with the SnO₂ sensor incorporated into the end of a flexible cord (1 ft long) connected to the lower surface of the metal box. The flexible cord allowed the metal box to be held in one hand while the SnO₂ sensor was held with the other hand and passed over opened drums and other containers. Very limited evaluations were performed with the second version of the handheld SnO₂ screening device.

3.4.3.3 Liquid Conductivity Device

The handheld conductivity device was developed from the conductivity sensor (Figure 2). The conductivity sensor and 10 light display were encased in a small metal box and powered by a rechargeable battery pack (approximately 8 hours between charges). The device was calibrated so that the tenth light represented the degradation level present in used oil sample No. 2 obtained from commercial airline 2 in Table 2.

The handheld liquid conductivity device was sent to Pratt & Whitney (West Palm Beach, FL) for field testing. Approximately 100 used oils (MIL-L-7808 type) from aircraft engines and test stands were tested with the handheld liquid conductivity device and another used oil degradation device, Complete Oil Breakdown Rate Analyzer (COBRA). The Pratt & Whitney personnel obtained good agreement between the degradation evaluations made by the handheld conductivity device and COBRA (Figure 7). COBRA readings above 10 are considered indicative of accelerated oil degradation. The results showed that the first light of the conductivity device was indicative of oil degradation and that none of the used oils exceeded two lights. Therefore, the handheld conductivity device will be recalibrated so that the tenth light is equal to COBRA readings of 30 to make the device more sensitive to low levels of oil degradation.

3.4.3.4 Viscosity and IR Devices

The handheld (commercial) and IR (lab-constructed) devices were evaluated for ease of operation and reliability. No further evaluation was performed during the research program.

3.5 TASK 4 - FEASIBILITY OF AN ECONOMICAL WASTE OIL MANAGEMENT PROGRAM

3.5.1 Introduction

In addition to developing and evaluating flow-through segregation systems and handheld screening devices, numerous contacts were made with used oil handlers, recyclers/reclaimers, reprocessors and so on, to determine the feasibility of developing an economical waste oil management program for the Air Force. Governmental regulations that will affect the initial setup and operation of an Air Force waste oil management program were also identified and evaluated in Task 4.

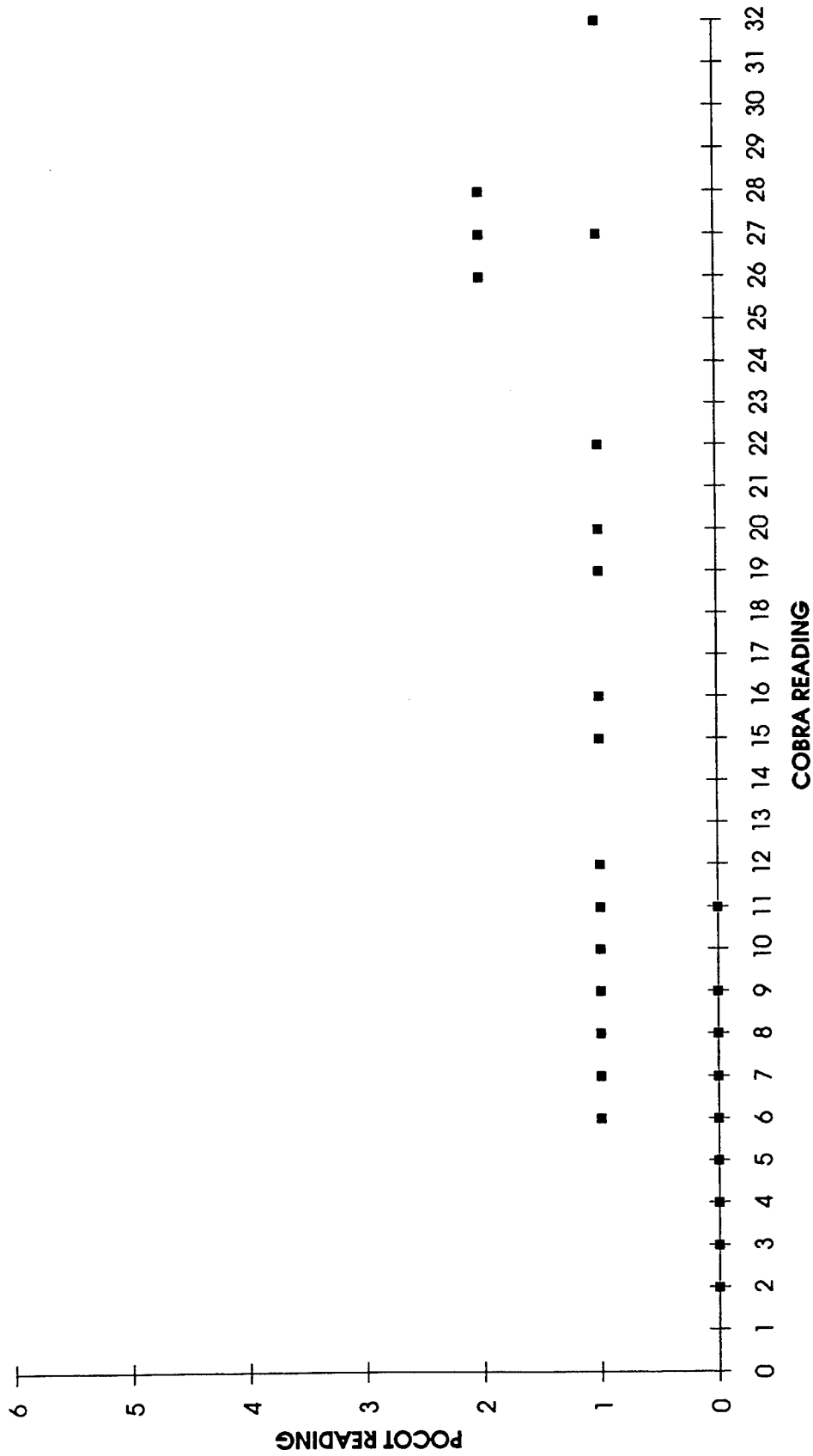

Figure 7. Plot of Portable Conductivity (POCOT) Screening Device Readings (Number of Lights) versus COBRA Readings for Used Aircraft Engine Oils (MIL-L-7808 and MIL-L-23699) Tested by Pratt & Whitney Personnel.

3.5.2 Waste Oil Reprocessors and Recyclers

In order for a waste oil management program to be successful, waste oil reprocessors and recyclers must be willing to purchase the waste oil collected and stored by the Air Force. Therefore, an initial survey of companies which have a wide range of uses for waste oil (reprocessing into basestock for automotive and refrigerant applications, fuel, plasticizers, etc.) was conducted to determine the interest level of different companies in purchasing non-contaminated waste oils from Air Force storage facilities. Of the various companies contacted during the survey, Mid-America Distillations (Hot Springs, AR) and similar companies which reprocess the used aircraft engine oils into ester basestocks for automotive and refrigeration applications are the most interested in buying waste oil from the Air Force. In fact, Mid-America Distillations is currently purchasing used oils obtained from engine tests performed at Kelly AFB.

Although Mid-America Distillations is able to reprocess used aircraft oils contaminated with solvents, chlorinated and nonchlorinated, the value of the used oil to Mid-America Distillations decreases rapidly as contamination increases. To determine the effects of contamination on the efficiency of reprocessing used aircraft engine oil, used oil No. 1 from Fort Smith (Table 1) was submitted to Mid-America Distillations for reprocessing. The volume of recovered ester basestock was less than 75% of the submitted used oil sample even though the contamination level was less than 3%. According to the reprocessor, contamination levels will have to be minimal (less than 0.1%) to reduce transportation costs and for recovered oil levels to be above 90%. The higher the recovery rates for the used oils, the more profitable the Air Force waste oil management system will be.

Other factors making the waste oil management system more feasible for the Air Force are newly enacted regulations requiring that the lubricants to be purchased by the government must contain at least 25% recycled or reprocessed basestock. Similar regulations for industrial purchasers of lubricants are being considered in state legislatures.

Further increasing the value of reprocessed ester basestock is the fact that recent studies with "ozone-friendly" refrigerants have shown that ester-based lubricants are the best candidates for use in automotive air conditioning compressors. Since all automotive air conditioning compressors will be using "ozone-friendly" refrigerant by 1995, the demand for ester basestocks will increase dramatically in the near future. Other types of commercial, industrial, and private air conditioning and refrigeration compressors are being converted to use "ozone-friendly" refrigerants further increasing the demand for ester basestocks.

Also, new automotive engine oil formulations are employing increasingly higher percentages of ester basestocks giving additional value to ester basestocks.

3.5.3 Government Regulations

3.5.3.1 Introduction

In addition to being economically feasible, the Air Force waste oil management program must meet the numerous city, state, and federal government regulations concerning the collection, monitoring, and transportation of waste lubricating oils. Although the city and state regulations will be dependent on the location of the Air Force waste oil dumps, several federal regulations will require consideration during the design and operation of any waste oil management program. The following federal laws have relevance to lubricating oil recycling:

- 40 CFR 279 - Standards for the Management of Used Oil
- 40 CFR 112 - Oil Pollution Prevention
- 40 CFR 113 - Liability Limits for Small Onshore Storage Facilities
- 40 CFR 252 - Guideline for Federal Procurement of Lubricating Oils Containing Re-refined Oils

The following laws are especially applicable for the setup of an Air Force waste oil management program:

- 40 CFR 280 - Underground Storage Tank Standards
- 33 CFR 154 - Response Requirements for Oil Spills

There are, in addition, several "guidance" requirements that will need to be considered during the storage of used aircraft engine oil. These include:

- RCRA 2005 - Labeling of Certain Oil
- API Standard 650 - Welded Steel Tanks for Oil Storage

The driving force for these requirements is 40 CFR 279, Subpart 54 which states: "Used oil processor/re-refiners are subject to all applicable Spill Prevention, Control and Countermeasures (SPCC) (40 CFR 112) in addition to the requirements of this subpart. Used oil processors/re-refiners are also subject to the Underground Storage Tank (40 CFR 280) standards for used oil stored in underground tanks whether or not the used oil exhibits

any characteristics of hazardous waste, in addition to the requirements of this subpart."

The regulation 40 CFR 112 then describes the construction and design requirements associated with such storage facilities, as well as outlining a capacity-based exemption to following SPCC requirements. Regardless of capacity, the requirements outlined in 40 CFR 279 are applicable to any used oil storage effort.

Although 40 CFR 113 is not specifically called out in 40 CFR 279, it must be judged as being "relevant and applicable" because it describes the legal liabilities associated with the onshore storage of any such lubricating oil. One additional regulation, 40 CFR 252 would be applicable for the consideration of standards which are required of lubricating oils were they to be redistributed to Federal facilities for reuse. RCRA 2005 briefly describes the labeling requirements for such re-refined oil. The American Petroleum Institute Standard 650 describes the construction requirements for any tank to be used for the storage of oil.

In association with these driving regulations, several other requirements may become applicable should the need arise for their consideration. The regulation 40 CFR 280 describes requirements for underground storage tanks were these type of units to be used for the temporary storage of such re-refined oil. Finally, 33 CFR 154 describes the procedures that must be followed in the event that a spill should occur from such storage facilities.

3.5.3.2 Standards for the Management of Used Oil (40 CFR 279)

Subpart F of this requirement describes the standards for used oil processors and re-refiners. According to these regulations, "Processing means chemical or physical operations designed to produce from used oil, or to make used oil more amenable for production of, fuel oils, lubricants, or other used oil-derived products. Processing includes, but is not limited to: blending used oil with virgin petroleum products, blending used oils to meet the fuel specification, filtration, simple distillation, chemical or physical separation and re-refining." Subpart F then states the transportation requirements for such oil, as well as the procedures that need to be followed in order to obtain an identification number from the United States Environmental Protection Agency (U.S. EPA) to operate a re-refining facility. Typically, this procedure involves nothing more than the preparation of a letter addressed to the U.S. EPA.

A list of requirements/standards for the operation of such a re-refining facility is also described in Subpart F. These requirements are rather specific, and include the general areas of:

- maintenance and operation
- required equipment
- testing of equipment
- communications and alarm systems
- aisle spacing
- arrangements with local authorities
- contingency plans/emergency procedures

Periodic testing for halogen content must be performed for these oils (40 CFR 279, Subpart 53). And, as was mentioned above, re-refining facilities must comply with SPCC requirements (40 CFR 279, Subpart 54).

3.5.3.3 Oil Pollution Prevention (40 CFR 112)

This regulatory requirement defines the construction standards for facilities that handle oils for the purpose of re-refining. "This part applies to owners or operators of nontransportation related onshore and offshore facilities engaged in drilling, producing, gathering, storing, processing, refining, transferring, distributing or consuming oil and oil products, and which due to their location, could reasonably be expected to discharge oil in harmful quantities..." There is a capacity cutoff, however, for the implementation or non-implementation of this regulation. Facilities are exempted from 40 CFR 112 if both of the following requirements are met: "The underground buried storage capacity of the facility is 42,000 gallons or less of oil, and the storage capacity, which is not buried, of the facility is 1320 gallons or less of oil, provided no single container has a capacity in excess of 660 gallons."

Subpart 7 of 40 CFR 112 details the guidelines for preparation of the SPCC. The general topic areas for the SPCC are as follows:

- collection facilities (dikes, sumps, curbs, etc.)
- tanks and lines
- detection equipment
- loading and unloading procedures
- inspection scheduling

3.5.3.4 Liability Limits for Small Onshore Storage Facilities (40 CFR 113)

The extent of dollar liability for the release of oil from any facility that is storing oil and has a fixed capacity of 1000 barrels or less is established in this regulation. As stated in the regulation:

"Unless the United States can show that oil was discharged as a result of willful negligence or willful misconduct within the privity and knowledge of the owner or operator, the following limits of liability are established for fixed onshore facilities in the classes specified":

a) Aboveground Storage

Size Class	Capacity (barrels)	Liability Limit (\$)
I	Up to 10	4,000
II	11 to 170	60,000
III	171 to 500	150,000
IV	501 to 1000	200,000

b) Below ground Storage

Size Class	Capacity (barrels)	Liability Limit (\$)
I	Up to 10	5,000
II	11 to 170	78,000
III	171 to 500	195,000
IV	501 to 1000	260,000

3.5.3.5 Guideline for Federal Procurement of Lubricating Oils Containing Re-refined Oil (40 CFR 252)

This regulation calls out the requirements that are placed on Federal facilities that purchase re-refined oils for the purpose of utilizing them as lubricating oils. "This guideline applies to all procuring agencies and to all procurement actions involving lubricating oils where the procuring agency purchases \$10,000 or more worth of one of these items during the course of a fiscal year..." The Affirmative Procurement provisions for lubricating oils, whereby the U.S. EPA recommends that 25% of all oils used for Federal facilities are recycled and re-refined in origin is called out in Subsection 21 of this regulation.

The exact specifications for these re-refined oils is described in Subsection 11 of 40 CFR 252. These include meeting the following mil specs as appropriate:

- MIL-L-46152B
- API Engine Service Category SF
- API Engine Service Category CC
- MIL-L-2104D
- API Engine Service Category CD
- MIL-L-21260D
- MIL-L-46167
- MIL-H-5606
- MIL-H-6083
- MIL-L-2105D

Copies of these military specifications can be obtained from: Commanding Officer, Naval Publications and Forms Center, 5801 Tabor Avenue, Philadelphia, Pennsylvania 19120.

3.5.3.6 Labeling of Certain Oil (RCRA 2005)

"For purposes of any provision of law which requires the labeling of commodities, lubricating oil shall be treated as lawfully labeled only if it bears the following statement, prominently displayed: DON'T POLLUTE - CONSERVE RESOURCES: RETURN USED OIL TO COLLECTION CENTERS."

3.5.3.7 Guidance for Locating and Operating a Small Test and Collection Facility for Used Turbine Oils

Even for the relatively small quantities that might be expected to be collected and accumulated at an engine test and repair facility, there are certain requirements that must be followed. These requirements will ensure that the collection and testing will be carried out in such a way as to absolutely minimize any chance of oil spillage resulting in a threat to the environment.

The requirements for control and containment of spills are based on the assumption that if a material can be spilled, then at some time it will. Thus, the guidance is designed to ensure that when a spill happens, the material will be safely contained and can be captured for recovery or appropriate disposal. The primary design concern thus is one of

ensuring that all transfer and storage take place in an area that is designed to contain spills and preclude their capability to flow to surface waters, to leach to groundwaters, or to volatilize to the atmosphere.

Because the candidate waste oils are relatively nonvolatile, no special consideration need be given to controlling loss of volatiles to the atmosphere. However, all of the oils that may be submitted for testing could flow unless confined. Therefore, the test and collection facility must incorporate a containment capability. The containment capability must be sufficient to contain the entire volume of all vessels stored at the site, plus the capacity of any test and transfer vessels used in the operation. In other words, even if everything spilled, it would still be completely contained and not be lost to the environment. This requirement can be achieved in different ways. In the case of a permanent operation, the facility should be designed to include a bermed storage and operation area. The volume of the bermed area (which may include an enclosed subgrade sump) must equal or exceed the required containment volume. In the case of a temporary operation, the containing berm can be provided by erecting a temporary berm of asphalt or cement on an unbroken, impermeable pad or paved area. For very short term operations, containment can be achieved by emplacing continuous lines of oil adsorbent material such as is sold for spill cleanup purposes.

All operations, including testing, transfer and storage of acceptable oils and rejects must be carried out within the confines of the bermed area. If the storage vessels are to be small (55-gallon) drums, and these drums are ultimately to be transferred to trucks for transport, then there must be equivalent containment capacity in the truck transfer area. For each facility at which these operations are to take place, an approved spill control, containment and countermeasures (SPCC) plan must be developed. Briefly, the SPCC plan must describe the operation, the nature of the materials that will be handled, the methods used to contain and control any spills, the methods for remediating a spill that does occur, and the personnel training measures to be used to ensure that the SPCC plans are followed. In addition, the local fire department and emergency response teams must be notified and given copies of the SPCC plans, so that they will be aware of any actions they may need to take as part of the response to any spill. A table of contents for a typical SPCC plan is the following:

- 1.0 Introduction (including a description of the planned operations)
- 2.0 Facility topology and drainage
- 3.0 General spill control and response procedures
- 4.0 Bulk storage areas covered by this plan

- 5.0 Notification requirements and procedures (fire dep't. & ERT)
- 6.0 Hazardous material transfer operations
- 7.0 Inspection and monitoring program
- 8.0 Personnel training

3.6 SUMMARY

An easy to operate, inexpensive flow-through segregation system has been developed which is capable of detecting contaminated and degraded used aircraft engine oils. The flow-through segregation system can also incorporate a viscometer to segregate used oils by viscosity grade (MIL-L-7808 versus MIL-L-23699).

In addition to the flow-through segregation system, three different type handheld screening devices have also been developed which sense volatile contaminants (SnO_2 detector), sense liquid contaminants (liquid conductivity detector) or determine the chemical class (IR detector) of used oils. A commercial handheld viscometer was also evaluated. The handheld screening devices were developed to allow incoming batches of used oils to be screened for contamination prior to being poured into the flow-through segregation system and to allow collected and stored used oils to be screened for contamination prior to transportation to waste oil reprocessing facilities.

The flow-through segregation system and handheld screening devices were evaluated with solvents and used aircraft engine oils obtained from military and commercial sites. The sensors in the flow-through and handheld systems accurately detected the used aircraft engine oils that contained unacceptable levels of chlorinated and cleaning solvents, jet fuels, and degradation products.

Surveys of waste oil handlers and reprocessors have shown that uncontaminated waste oils from aircraft engines have economic value for reprocessors producing ester basestocks for automotive and refrigeration applications. The economic value of the used aircraft engine oils increases exponentially with decreasing contamination, especially halogenated contamination. A brief survey of governmental regulations affecting the setup and operation of a waste oil management program was also conducted.

Therefore, the research described in this report demonstrates that a waste oil management program with both economical and environmental benefits can be developed and operated for the Air Force aircraft fleet.

SECTION 4

CONCLUSIONS AND RECOMMENDATIONS

The following conclusions and recommendations have been made regarding the development and operation of a waste oil management program for the Air Force aircraft fleet.

- Demand for ester basestocks produced by reprocessing used aircraft engine oils will increase in the near future.
- Environmental and economic trends make a waste oil management program for the Air Force aircraft fleet feasible and increasingly necessary and beneficial.
- Developed segregation systems and screening devices are capable of ensuring collected and stored used aircraft engine oils are free of contamination.
- Field tests should be performed to evaluate the capabilities of the developed segregation system and screening devices when operated by nontechnical Air Force personnel.
- Develop and evaluate segregation systems and screening devices for use with nonaircraft engine oils used by the Air Force such as hydraulic fluids.
- Prototype used oil management programs should be set up and operated at selected Air Force sites to determine the economic and environmental benefits of used oil segregation for military and commercial maintenance operations.