

AL/HR-TP-1994-0030



**ARMSTRONG
LABORATORY**

HUMAN ISSUES IN TECHNOLOGY IMPLEMENTATION

**David I. Cleland
Bopaya Bidanda
Christopher A. Chung**

**The University of Pittsburgh
Department of Industrial Engineering
Manufacturing Assistance Center
1072 Benedum Hall
Pittsburgh, Pennsylvania 15261**

**DTIC
ELECTE
MAR 15 1995
S G D**

**HUMAN RESOURCES DIRECTORATE
LOGISTICS RESEARCH DIVISION
2698 G Street
Wright-Patterson Air Force Base, Ohio 45433-7604**

December 1994

19950314 097

Final Technical Paper for Period April 1992 to February 1994

Approved for public release; distribution is unlimited

**AIR FORCE MATERIEL COMMAND
WRIGHT-PATTERSON AIR FORCE BASE, OHIO 45433-6573**

NOTICES

When Government drawings, specifications, or other data are used for any purpose other than in connection with a definitely Government-related procurement, the United States Government incurs no responsibility or any obligation whatsoever. The fact that the Government may have formulated or in any way supplied the said drawings, specifications, or other data, is not to be regarded by implication, or otherwise in any manner construed, as licensing the holder, or any other person or corporation, or as conveying any rights or permission to manufacture, use, or sell any patented invention that may in any way be related thereto.

The Public Affairs Office has reviewed this paper and it is releasable to the National Technical Information Service, where it will be available to the general public, including foreign nationals.

This paper has been reviewed and is approved for publication.

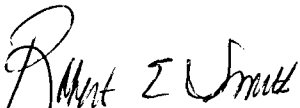

ROBERT E. SMITH, Capt, USAF
Contract Monitor



BERTRAM W. CREAM, Chief
Logistics Research Division

REPORT DOCUMENTATION PAGE

Form Approved
OMB No. 0704-0188

Public reporting burden for this collection of information is estimated to average 1 hour per response, including the time for reviewing instructions, searching existing data sources, gathering and maintaining the data needed, and completing and reviewing the collection of information. Send comments regarding this burden estimate or any other aspect of this collection of information, including suggestions for reducing this burden, to Washington Headquarters Services, Directorate for Information Operations and Reports, 1215 Jefferson Davis Highway, Suite 1204, Arlington, VA 22202-4302, and to the Office of Management and Budget, Paperwork Reduction Project (0704-0188), Washington, DC 20503.

1. AGENCY USE ONLY (Leave blank)	2. REPORT DATE December 1994	3. REPORT TYPE AND DATES COVERED Final - Apr 1992 to Feb 1994
---	--	---

4. TITLE AND SUBTITLE Human Issues in Technology Implementation	5. FUNDING NUMBERS C - F33657-92-D-2171 PE - 62205F PR - 1710 TA - 00 WU - 40
6. AUTHOR(S) David I. Cleland Bopaya Bidanda Christopher A. Chung	

7. PERFORMING ORGANIZATION NAME(S) AND ADDRESS(ES) The University of Pittsburg Department of Industrial Engineering Manufacturing Assistance Center 1072 Benedum Hall Pittsburg PA 15261	8. PERFORMING ORGANIZATION REPORT NUMBER
--	---

9. SPONSORING / MONITORING AGENCY NAME(S) AND ADDRESS(ES) Armstrong Laboratory Human Resources Directorate Logistics Research Division 2698 G Street Wright-Patterson AFB, OH 45433-7604	10. SPONSORING / MONITORING AGENCY REPORT NUMBER AL/HR-TP-1994-0030
--	---

11. SUPPLEMENTARY NOTES
Armstrong Laboratory Technical Monitor: Capt Robert Smith, AL/HRGA, DSN 785-7773

12a. DISTRIBUTION / AVAILABILITY STATEMENT Approved for public release; distribution is unlimited	12b. DISTRIBUTION CODE
---	-------------------------------

13. ABSTRACT (Maximum 200 words)

The overall objective of this research was to address the human issues associated with the implementation of new technology in manufacturing environments. The research participants were two airframers and a major electronics firm. The objectives of the research were attained by: 1) executing a comprehensive literature search and evaluation; 2) developing a data collection package; 3) administering the package to the major electronics firms; 4) improving the data collection package through feedback from the electronics firms; 5) administering the revised version to the airframers; and 6) analyzing the findings and presenting the results.

14. SUBJECT TERMS concurrent engineering culture flexible manufacturing systems (fms)	human centered sociotechnical	15. NUMBER OF PAGES 105
		16. PRICE CODE

17. SECURITY CLASSIFICATION OF REPORT Unclassified	18. SECURITY CLASSIFICATION OF THIS PAGE Unclassified	19. SECURITY CLASSIFICATION OF ABSTRACT Unclassified	20. LIMITATION OF ABSTRACT SAR
--	---	--	--

TABLE OF CONTENTS

<u>Section</u>	<u>Page</u>
List of Figures	iii
List of Acronyms	v
Preface	vi
1.0 SUMMARY	1
2.0 INTRODUCTION	4
2.1 Challenges Facing United States Manufacturers	4
2.2 Human Issues in Technology Implementation Study	6
3.0 METHODS	7
3.1 Literature Search	7
3.2 Study Population	18
3.3 Data Collection Packet	18
3.4 Data Analysis Procedures	20
4.0 LIMITATIONS	25
5.0 RESULTS AND DISCUSSION	26
5.1 Air 1	26
5.2 Air 2	44
6.0 CONCLUSIONS	64
7.0 RECOMMENDATIONS	66
7.1 Phase II Human Issues in Technology Reseach, Application, and Implementation Laboratory.	66
REFERENCES	71
APPENDIX A	78
APPENDIX B	85

Accession For	
NTIS CRA&I	<input checked="" type="checkbox"/>
DTIC TAB	<input type="checkbox"/>
Unannounced	<input type="checkbox"/>
Justification _____	
By _____	
Distribution / _____	
Availability Codes	
Dist	Avail and/or Special
A-1	

LIST OF FIGURES

<u>Figure</u>		<u>Page</u>
1	U.S. Efforts to Adopt Advanced Manufacturing Technology	5
2	Box and Whisker Plot	22
3	Air 1 Technological Philosophy	27
4	Air 1 Technological Champion	28
5	Air 1 Worker Involvement in Planning and Selection	29
6	Air 1 Level of Introduction	30
7	Air 1 Reorganization	31
8	Air 1 New Demands on Workers	32
9	Air 1 Reduction of Resistance to New Technology	33
10	Air 1 Performance Evaluation and Pay	34
11	Air 1 Decision Levels and Empowerment	35
12	Air 1 Success and Satisfaction	36
13	Air 1 Worker Approach to Implementation Improvement	41
14	Air 1 Management/Supervisor Approach to Implementation Improvement	42
15	Air 2 Technological Philosophy	45
16	Air 2 Technological Champion	46
17	Air 2 Worker Involvement in Planning and Selection	47
18	Air 2 Level of Introduction	48
19	Air 2 Reorganization	49
20	Air 2 New Demands on Workers	50
21	Air 2 Reduction of Resistance to New Technology	51
22	Air 2 Performance Evaluation and Pay	52
23	Air 2 Decision Levels and Empowerment	53
24	Air 2 Success and Satisfaction	54
25	Air 2 Worker Approach to Implementation Improvement	60
26	Air 2 Management/Supervisor Approach to Implementation Improvement	61
27	Air 2 Staff Approach to Implementation Improvement	62
28	Synergistic MAC Laboratory Network	66
29	HITRAIL Mission	67

LIST OF ACRONYMS

AMT	Advanced Manufacturing Technology
CAD	Computer Aided Drafting
CAM	Computer Aided Manufacturing
CIM	Computer Integrated Manufacturing
FMS	Flexible Manufacturing Systems
HIM	Human Integrated Manufacturing
JIT	Just in Time

PREFACE

The work described in the final report supports the Armstrong Laboratory Logistics Research Division (AL/HRG) mission to improve the Air Force's ability to procure, implement, and maintain advanced technologies. The Air Force, through the programs initiated at Armstrong Laboratory, is addressing the critical role played by the human in existing and proposed advanced technology acquisitions. This effort has identified critical factors associated with the successful implementation of advanced technologies within the manufacturing domain.

This report is submitted to satisfy Data Item A006, Scientific and Technical Reports. The performing project team comprised two faculty from the Industrial Engineering Department and a doctoral student at the University of Pittsburgh. Principal Investigators were Dr. David I. Cleland and Dr. Bopaya Bidanda, University of Pittsburgh faculty, and the Research Assistant was Mr. Christopher Chung, doctoral student at the University. Our team gratefully acknowledges the guidance of the contract monitor, Captain Robert Smith; the watchful oversight of Mr. Tim Reser, representing the prime contractor, RJO Enterprises, Inc.; and the help of our support staff.

1.0 SUMMARY

This research was conducted under the sponsorship of United States Air Force Armstrong Laboratory grant number F33657-92-D-2171-RZ05.

The objective of Phase I of this research is to gather information and formulate a comprehensive program plan to address the Human Issues in Technology Implementation (HITI).

The first component of this objective was achieved through the following:

- (1) Execution of a comprehensive literature review.
- (2) Development of a data collection packet.
- (3) Administration of the packet to two USAF airframe contractors.
- (4) Analysis of that data.

The review of the existing body of literature indicates that the critical HITI include the following:

- (1) Technological philosophy. An organization's philosophical approach to technology implementation, consisting of a set of general underlying values with respect to human and computer roles in manufacturing processes.
- (2) Level and timing of worker participation in the planning and implementation of the technology.
- (3) Level and rate of technology implementation on the shop floor.
- (4) Technology champion. The presence of high-level management individuals to provide encouragement for implementing technology.

- (5) Level of employee knowledge, skill, and commitment. New technology places increased demands on worker capabilities.
- (6) Training and education. The use of education and training to specifically reduce fear of the unknown, fear of failure, fear of job loss.
- (7) Performance evaluation and rewards systems. Modifications to evaluation and pay systems to accommodate changes brought by technology.
- (8) Organizational design. The use of alternative work force structures such as teams.
- (9) Employee decision-making and empowerment. Increasing empowerment when technology provides information for decision-making.

A data collection packet based on these issues was developed to assess the effectiveness of organizational HITI efforts. The packet was administered to two United States Air Force airframe contractors in September 1993. Analysis of this data indicates that opportunity for improvement of the HITI is present in both organizations. Pareto analysis of both organizations indicates that the greatest opportunity exists in the area of early and significant worker participation in the planning and selection of new technology. Workers indicated that participation in the planning and selection of new technology occurred on a limited basis and was of significant importance in the success and satisfaction of the implementation. This and other information obtained from the study was utilized to develop strategies for improving these contractors' organizational efforts in the human issues area.

The second component of the Phase I objective is the formulation of a comprehensive Phase II program plan to capitalize on

the findings in Phase I. Phase II will consist of the creation of a Human Issues in Technology Research, Application, and Implementation Laboratory (HITRAIL). Initial activities of the HITRAIL include the development of an HITI Assessment Tool, an HITI Management Simulator, and an HITI On-Line Database.

2.0 INTRODUCTION

This section reviews historical technological implementation efforts, defines the objective of the study, and describes the organization of the report.

2.1 Challenges Facing United States Manufacturers

A popular organizational strategy to improve long-term manufacturing competitiveness is the adoption of advanced manufacturing technology (AMT). Consisting of computer numerically controlled machines (CNC), computer-aided design (CAD), computer-aided manufacturing (CAM), computer-integrated manufacturing (CIM), robotics, and flexible manufacturing systems (FMS); AMT has the potential to improve product quality, increase process flexibility, and reduce manufacturing cycle time. This improved capability results in greater customer responsiveness and lower manufacturer operating costs.

These advantages entice many organizations to adopt AMT, however, experts believe that as much as 50 to 75 percent of these efforts fail (1, 2, 3). The 1985 General Motors Cadillac Hamtramck and Buick City plant start-ups are representative of such failures (4, 5, 6). Facing increased foreign competition, GM sought strategic advantage through high-technology manufacturing solutions. This approach resulted in severe production and quality problems throughout the plant start-ups, eventually forcing a drastic reduction of the AMT.

Many sources attribute this and other failures to inadequate attention to the human element involved in the technology implementation efforts (7, 8, 9, 10). As a 1984 report of the United States Government, Office of Technology Assessment, states:

...the main stumbling blocks in the near future for the implementation of programmable automation technology are not technical, but rather are barriers of cost, organization of the factory, availability of skills, and the social effects of these technologies...(11)

Thus, one of the future challenges for successful implementations lies in addressing the unique needs imposed by advanced manufacturing technology on the human element; successful efforts can be expected to lead to both improved organizational and U.S. manufacturing competitiveness. This approach is summarized in Figure 1, U.S. Efforts to Adopt Advanced Manufacturing Technology.

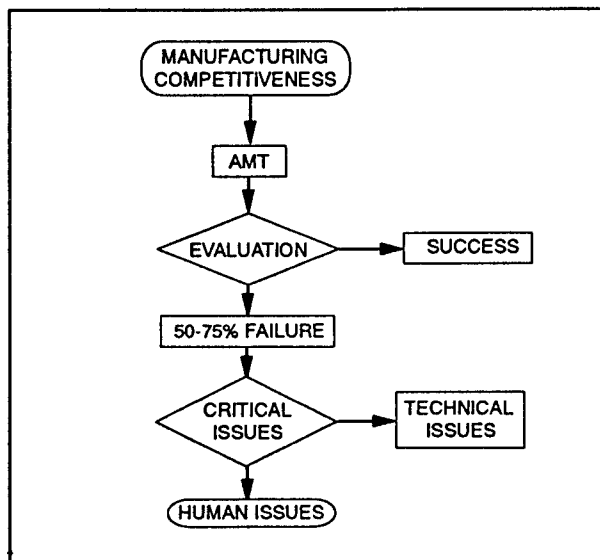

Figure 1 U.S. Efforts to Adopt Advanced Manufacturing Technology

2.2 Human Issues in Technology Implementation Study

The objective of this study was to gather information and formulate a comprehensive plan for a program addressing the critical human issues relevant to the successful implementation of technology. This objective was achieved through the execution of a comprehensive literature search, development of a data collection packet, administration of the packet to two USAF airframe contractors, and analysis of that data. This information is organized into the following sections:

- (1) Methods. Information on the literature search, the study population, the data collection packet, and the data analysis procedures.
- (2) Assumptions and Limitations. The assumptions and limitations under which the study results were developed.
- (3) Results and Discussion. Results and discussion on the information generated from the data analysis.
- (4) Conclusions. Summary and discussion of the implications of the results.
- (5) Recommendations. Possible courses of action based on the results of the study.

3.0 METHODS

This section includes information concerning the literature search, study population, data collection packet, and data analysis procedures. The literature search results provide background for the data collection packet. They are included in this section.

3.1 Literature Search

The objective of the literature review is to identify contemporary human issues practices which are factors in the successful implementation of AMT. This part of the literature review concentrates on collecting information on existing theories and practices, rather than determining potential areas for future research. The resulting review has yielded work in the areas of: philosophical approach, planning and implementation, employees, organizational issues, and implementation success measurements.

3.1.1 Philosophical Approaches to Technology Planning and Implementation

An organization's philosophical approach to technology implementation consists of the set of general underlying values with respect to human and computer roles in manufacturing processes. Technocentric and human centered approaches are divergent ends of the philosophical spectrum.

3.1.1.1 Technocentric Approach. The technocentric approach is most commonly associated with technology implementation in the United States. This approach subordinates human issues to technical issues and is defined by Ebel as containing the following principles (12).

- (1) Humans are unpredictable, troublesome, and unreliable components of the manufacturing process.
- (2) Manufacturing systems should be designed to minimize the need for human intervention.
- (3) Manufacturing systems should be controlled by computers in order to provide flexible and rapid response to market demand.

The technocentric philosophy is prevalent in the United States and is the basis for the unmanned and "lights out" factory concepts. Badham, Corbett, and Flynn associate this approach with the deskilling or reduction of skills among the work force (13, 14, 15).

3.1.1.2 Human-Centered Approach. The human-centered philosophical approach is also known as the Socio-Technical, Human-Integrated Manufacturing (HIM), or People-Integrated Manufacturing (PIM) approach. Badham and Corbett conceptualize this approach with the idea of computer-aided craftspersons who embrace the following principles (16, 17).

- (1) Workers are accepted as having skills, and the development of those skills is encouraged.
- (2) Workers are supported by and have the freedom to control technology.

- (3) Workers are multiskilled, and divisions of skill are discouraged.
- (4) Communication and interaction among workers is encouraged.

Though many of these concepts are currently in use throughout the world, including the Pacific Rim, Badham credits the human-centered approach as originating in the United Kingdom, Scandinavia, and Germany (18).

3.1.2 Planning and Implementation Issues

Planning and implementation issues are associated with scheduling and methods of adoption utilized by organizations. These issues include the scope of the implementation changes, the timing of the implementation, the methods of introduction, and the execution of the implementation.

3.1.2.1 Scope. The scope of the planning and implementation concerns the degree to which technical, organizational, and worker issues are changed in the implementation. However, Tippett cites a frequent theme in the unsuccessful implementation of technology as the lack of attention to human issues in the planning stages (19). The same consideration in planning must be given to human issues as with technical issues if the expected benefits are to be attained.

3.1.2.2 Timing. The timing of technical, organizational, and worker issues is critical to the success of the technology

planning and implementation. Derven, Gupta, and Rennels conclude that involvement of users early in the implementation process ensures that the technology will meet the users' needs as well as assist in reducing resistance (20, 21, 22).

3.1.2.3 Method of Introduction. Hurst suggests that pilot projects appear to be the most successful method of introducing major technological changes (23). This approach is also supported by Chew, who suggests using simulation in combination with pilot projects (24). While vendors most often play a principal role in the introduction, alternative methods include the training of supervisor and/or peers by the vendor and the introduction of the technology by the supervisor and/or peer.

3.1.2.4 Level of Employee Participation. O'Brien and Kroggel claim that a frequent theme of technology planning and implementation is the system design and selection by upper management or staff specialists (25). Ettkin and O'Brien say planning and implementation in this manner wastes the benefit of worker knowledge and removes the employees' senses of involvement, ownership, and pride in their work (26, 27). Gupta, Kuhlmann, Rennels, and Alter conclude that active employee involvement in each stage of the planning and implementation will generate a sense of control and reduce resistance (28, 29, 30, 31).

3.1.2.5 Technology Implementation Champion. Beatty and Gordon, and to a lesser extent Norman and Corbitt, investigate the

influence of effective technology champions in the successful adoption of AMT (32, 33, 34, 35, 36, 37). These technology champions support the planning and implementation through their vision for utilizing AMT, their knowledge of computers and the applicable process, and their general project management skills.

3.1.3 Employee Issues

Employee issues which may impact the success of technology planning and implementation are selection characteristics, resistance, training, and reward systems.

3.1.3.1 Selection Characteristics. The adoption of AMT changes the standards required of the workforce. Hornsby, Ebel, Andreicuk, and Goldhar conclude that employees who operate AMT must be capable in terms of knowledge, skills, and attitudes (38, 39, 40, 41).

AMT frequently results in the presence of several types of bodies of knowledge in a single system. An automated FMS, for example, may include computer, electrical, hydraulic, pneumatic, and mechanical technologies. Thus, in order to properly operate and perform first-line maintenance and diagnostics, Bessant believes that the worker must possess significant knowledge of many technologies (42).

Similarly, Gupta suggests that the increased communication and interaction among the workforce in human-centered approaches

requires that workers possess greater communication and interpersonal skills (43).

Finally, Helfgott and Oliver have investigated the concept that workers must possess the correct attitude to utilize AMT (44, 45). They conclude that the workers must specifically exhibit increased adaptability and flexibility. Furthermore, if the organization utilizes Just-in-time (JIT) principles, the workers must be disciplined.

3.1.3.2 Resistance. O'Brien, Ettkin, and Nota identify employee resistance to change as one of the most troublesome factors in technology implementation (46, 47, 48, 49). Wessler and Fought see resistance as being present in both management and the workforce (50). The causes of employee resistance are identified by Tobias as fear of the unknown, fear of failure, fear of job loss, and fear of power loss (51). Fear of the unknown constitutes employee concerns over moving from a known situation into one of unfamiliarity and uncertainty. Fear of failure is the concern that workers will not be able to master the new demands generated by the new technology. Fear of job loss is associated with the possibility of job elimination or change as a result of automation. Finally, fear of power loss is present in management and supervisor levels where the increased integration of new technology will bring about management changes.

Because worker and manager resistance to change has been identified as a major factor in the success of technology implementation, significant effort has been directed towards over-

coming resistance. Ettkin identifies effective efforts of overcoming resistance to include worker involvement, communication, and training (52). Involvement includes worker participation in the planning, selection, and implementation processes. Alternatively, Kuhlmann suggests that organizations may attempt to reduce resistance through the constant communication of planning and implementation impact on the workforce (53).

3.1.3.3 Training. Bessant, Hornsby, Rennels, and Helfgott see the adoption of AMT as requiring extensive investment in both the training of new employees and the retraining of existing employees (54, 55, 56, 57, 58). Significant organizational choices in this area concern the source and methods of training.

While many sources for new technology training exist, training is most often provided by the equipment vendor. A better situation exists if the employees play a participative role early in the implementation. In this case, Rennels believes that select employees can receive training prior to the arrival of the new equipment and assist in the training of other employees after it arrives (59). Finally, since technology is continuously changing, Helfgott, Ross, and Hayes see training as a continuous process (60, 61, 62).

Method of training is another important research area of AMT. Training methods range from conventional types of training to more advanced types, including the use of equipment simulators. As with other types of simulators, AMT simulators will allow training for both familiarization and response purposes.

3.1.3.4 Reward Systems. Alter and Hornsby have investigated the need for organizations utilizing advanced technology to utilize different systems to reward worker performance (63, 64). The use of automated FMSs, for example, typically reduces the number of job skill categories. Similarly, Recardo has found that organizations which operate under JIT principles cannot reward simply on numerical productivity (65). Two reward systems which appear to support AMT are skill-based pay and gainsharing programs.

Skill-based pay systems, as described by Alder and Johnson, are often found in automated FMSs (66, 67). This type of system rewards workers on the basis of the number and depth of skills mastered. This concept encourages job rotation and the development of cross-functional skills. Once workers reach the maximum pay level for the cell, they are given the opportunity to train in areas external to the cell.

Gainsharing programs encourage the improvement of the input/output productivity relationship. Employees receive a periodic bonus based on the increase of the productivity relationship over a baseline value.

3.1.4 Organizational Issues

The concept that successful implementation of AMT can only be realized if supported by similarly advanced organizational developments has been addressed by Bessant, Helfgott, and Ross (68, 69, 70). Organizational changes may be required in organi-

zational design, production team composition, and management style.

3.1.4.1 Organizational Design. AMT provides organizations with the potential for increased flexibility and responsiveness. In order to fully realize this improved flexibility and responsiveness, changes in organizational design must occur at both high and low levels. At the functional level, barriers between departments must be removed. At the shop floor level, Martin believes that manufacturing must be reorganized into autonomous units which can function independently based on local demands (71).

3.1.4.2 Organizational Structure and Teams. AMT impacts both between and within an organization's functional departments. On the functional level, AMT permits improved interdepartmental information-sharing. However, this improved capability may be restricted by the existence of functional barriers. Hayes and Beatty conclude that the use of multifunctional teams for activities such as simultaneous engineering enables organizations to exploit the enhanced flexibility and responsiveness capabilities of AMT (72, 73).

Within manufacturing departments, the presence of different technologies in AMT also impacts production team composition. These systems require both multiskilled operators and maintenance workers. Thus, Ebel predicts production team composition will change from a few workers in each of many different specialized

areas to many workers in a few multiskilled categories (74). Bessant projects that this reduction in functional specialization results in additional horizontal integration with a corresponding reduction in vertical organizational levels (75).

3.1.4.3 Management Style. The extensive information capability of AMT systems allows critical production information to be accessed at the shop-floor level. Badham and Parden state that this improved access permits decision-making to be lowered to the operator level (76, 77). With decision-making and multiskilled capability, the workforce can now operate as semiautonomous teams. A consequence of these changes is the redefinition of the role of the first-line supervisor and the middle manager. In this context, Bessant, Altany, and Gupta now view these individuals as a resource for facilitating the process (78, 79, 80).

3.1.5 Implementation Success

A number of attempts have been made to assess the success of a technological implementation. Assessment methods range from the examination of production records to the administration of surveys. Ettlle and Jaikumar based success on production records including downtime, utilization rates, and parts per system in comparison to similar Japanese manufacturers (81, 82). Uzumeri administered a survey focusing on flexibility, downtime, labor reduction, cycle time, quality, and reduced work in progress from a technology buyer's viewpoint (83). Many others such as Freeman

and Beale have concentrated strictly on the financial aspects of the implementation (84).

While these strictly objective measures may provide information on the final technical result of the implementation, a comprehensive examination must also include success from a human viewpoint. For this reason, behavioral aspects indicating success and satisfaction must also be included. Well-established indicators in this area include turnover, absenteeism, tardiness, and grievances (85).

3.1.6 Summary of Critical Human Issues in Technology Implementation

The review of the current literature on HITI has yielded a number of consistent concepts in the successful adoption of AMT. The following hypotheses are proposed as elements necessary for successful technological implementation:

- (1) Use of a human-centered philosophy that encompasses the concept of the computer-aided craftsman, who is both supported by and in control of the technology.
- (2) Early and significant worker participation in the planning and implementation of the technology.
- (3) Initial introduction of the technology by utilizing pilot projects.
- (4) Presence of a technology implementation champion.
- (5) Selection and training of employees so they are more capable in terms of knowledge, skills, and attitudes.
- (6) Direction of effort towards overcoming resistance to new technology.
- (7) Improving performance evaluation and rewards systems.

- (8) Improving organizational design with technology implementation (simultaneous engineering, production teams, cross-functional teams).
- (9) Improving flexibility and responsiveness by placing decision-making authority at the lowest level which has access to the necessary information.

3.2 Study Population

The primary study population for the HITI Data Collection Packet is USAF airframe contractor production workers who currently utilize AMT. Focus on this population is based on the reality that the nine human issues primarily impact the production workers who are in direct contact with the technology and that the pilot testing indicated that only very limited sample sizes, such as supervisors and engineering staff, are available from other groups.

3.3 Data Collection Packet

3.3.1 Design

The data collection packet consists of a survey and questionnaire. The objective of the survey is to determine both the perceived level of activity and the importance of each human issue identified in the literature search. The objective of the questionnaire is to obtain more detailed information on the organization's human issue practices.

3.3.1.1 Special Considerations. A significant problem in the design of the survey and questionnaire is the accessibility of the study population. Since administration of the data collection packet would disrupt the production operations of the participating organizations, the number of survey and questionnaire items is severely constrained. A similar constraint exists in the limited number of potential individual participants, which prevented the performance of classical internal reliability testing.

3.3.1.2 Survey. The survey consists of two components. The first component is a series of twenty statements to which the participants respond according to their level of agreement/disagreement. Eighteen of these statements relate to the nine human issues identified in the literature search. Two additional statements addressing the success of the implementation are also included.

The second component is a series of nine questions pertaining to the level of importance which the participants place on each of the human issues. A final question solicits information on the survey itself.

In both components, the participants respond to statements on a five-point Likert scale varying from disagree strongly to agree strongly. A copy of the survey is included in Appendix A.

3.3.1.3 Questionnaire. The final version of the questionnaire consists of ten questions. The questions address current human

issues programs, performance evaluation methods, quality of work life, and benefits of effective human issues programs. A copy of the questionnaire is included in Appendix B.

3.3.2 Validation, Pilot Administration, and Refinement

Face validity and continuous improvement of the initial data packet was performed through a series of seven sessions with the management, workforce, and union of the Modular Cutting Group of the Packard Electric Division of GM between December 1992 and March 1993. The recent adoption of computerized technology for automobile wiring harness cutting processes by this group provided an ideal opportunity for pilot testing and administration of the packet to people who had experienced a real-world implementation. Specific survey improvement occurred in the areas of question structure, vocabulary choice, survey briefing techniques, and administration requirements.

3.4 Data Analysis Procedures

This section specifies the procedures utilized for analyzing the survey and questionnaire data.

3.4.1 Data Limitations and Consequences

The procedures employed to analyze the existing data was subject to the sample sizes available from the USAF airframe contractors. The number of participants at both sites was first

limited by funding and production constraints. Further reduction occurred through absenteeism by scheduled participants. As a result of reducing sample sizes, a principal statistical analysis procedure, multiple regression could not be conducted. Given the limited sample sizes, statistical analysis concentrated on comparative box and whisker plots and the development of Pareto charts to determine implementation improvement strategies.

3.4.2 Survey Data

Analysis of the survey-acquired data included box and whisker quartile plots, importance ranking of the critical issues, and a Pareto chart. Each of these techniques is described in detail below.

3.4.2.1 Processing of Raw Survey Data. The five-point Likert scale yielded individual scores for each issue between zero and four. Statements worded negatively were reverse scored. The matching questions for each issue were combined for a score between zero and eight. Finally, to normalize the scores between zero and ten, each issue result was multiplied by a factor of 1.25.

The importance of the issues were represented by a single item. The normalization for these questions consisted of multiplying the raw score of zero to four by a factor of 2.5.

3.4.2.2 Box and Whisker Quartile Plots. Box and whisker quartile plots provide a graphical representation of the refined data. This technique illustrates the maximum, minimum, first quartile (75% of all responses), third quartile (25% of all responses), and median responses for each issue by employee category. The manner in which these statistical values are represented is illustrated in Figure 2.

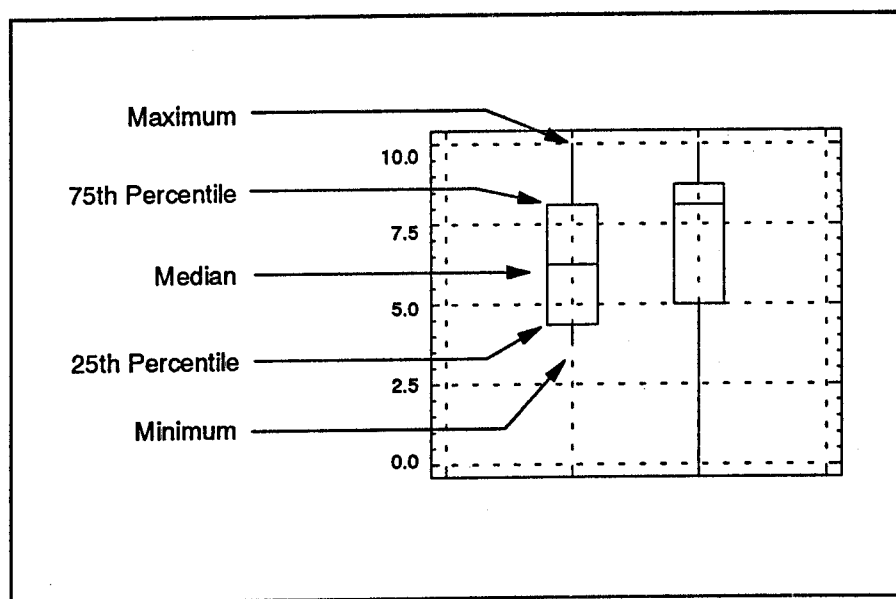

Figure 2: Box and Whisker Plot

Box and whisker plots are helpful in determining both the level and range of responses. The position of the box and whiskers indicate the organizational practices with respect to each issue. The width of the box and whiskers indicates the degree of consistency of the responses. Thus, plots with small boxes and whiskers at one end of the graph offer the best opportunity for meaningful conclusions.

3.4.2.3 Importance Rankings. Importance rankings were determined by calculating the mean response to each of the issues. The mean scores were then ranked in descending order.

3.4.2.4 Pareto Charts. Pareto charts are a means of graphically illustrating the proportion of benefits or problems attributable to individual factors within a system. The pareto charts for this project determine where the most attention should be directed to improve human issues efforts. Thus, more attention should be directed to the human issues of greater importance, but of which the organization is weak. Conversely, human issues which are well addressed and of lesser importance need less attention.

The pareto charts were developed by multiplying the amount of possible improvement in each issue by the level of importance given to that issue. The amount of possible improvement was determined by the difference between the ideal score of 10 and the mean score for the level of presence for the issue. The final step consisted of calculating and sorting the mean scores for the issues.

3.4.3 Questionnaire Data

Open-ended data collection instruments such as the questionnaire can be expected to yield a wide variety of responses. The analysis of this data consisted of attempting to identify both repetitive themes and unique insight.

3.4.4 Field Data Collection Procedures

The administration of the data collection packet consisted of a brief orientation on the importance and benefits of the project to the participating organization. Following the orientation, the data collection packet was distributed. During the administration, members of the HITI team were available for survey and questionnaire clarification.

4.0 LIMITATIONS

This section includes the assumptions and limitations under which this study was conducted.

Four USAF airframe contractors using AMT were originally contacted. They each agreed to participate in the HITI project. Prior to scheduling the site visit, Air 4 withdrew participation commitment, citing economic difficulties. A second contractor, Air 3 also dropped out of the project less than 24 hours prior to the scheduled visit, citing security clearance difficulties. The remaining contractors were visited on 20 and 22 September 1993.

Other difficulties occurred with the lack individual participants at each location. Production and funding constraints and absenteeism resulted in only seventeen Air 1 and twenty-four Air 2 participants. As discussed in the data analysis section, the reduced number of participants prevented the performance of multiple regression analyses.

A final limitation existed in the area of technology implementation. The employees available for this study were predominately from production areas that utilize AMT. Thus, the results of this study are limited to this area of technology implementations.

5.0 RESULTS AND DISCUSSION

This section includes Air 1 and Air 2 data analysis results.

5.1 Air 1

The 20 September 1993 Air 1 site visit consisted of a series of general corporate and Continuous Improvement Program briefings, a plant tour, and administration of the data collection packet. The plant tour included the advanced composites manufacturing and wing assembly areas. Administration of the data collection packet consisted of an orientation briefing and distribution of the packet. The following Air 1 employees completed the Data Collection Packet:

8	Team Workers
2	Supervisors/Facilitators
5	Manufacturing Management Members
2	Engineers
17	Total

5.1.1 Survey Data Box and Whisker Plots

The following box and whisker plots were developed as specified in the Methods section of this report.

5.1.1.1 Technological Philosophy. The worker perception of the technological philosophy slightly favors the concept of the computer-aided craftsman. This perception is also generally present among the management, though a few responses disagreed. The workers, management, and supervisors groups clearly recognize the impact of the technological philosophy on the success of the implementation, as illustrated in Figure 3.

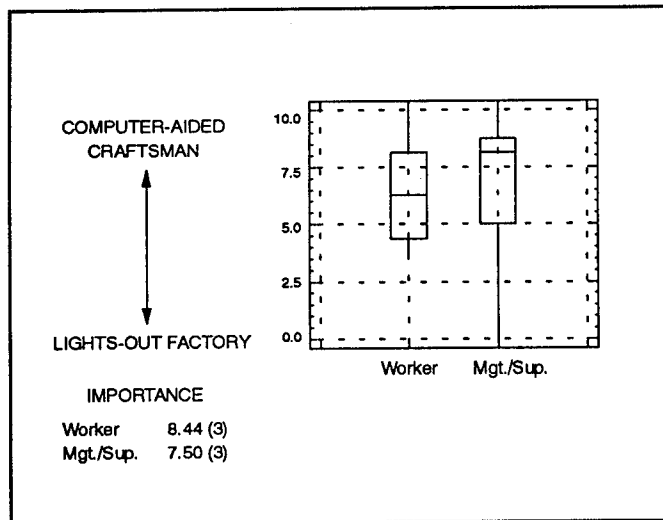

Figure 3: Air 1 Technological Philosophy

5.1.1.2 Technological Champion. Both worker and management responses indicated a moderate presence of a technological champion during implementations. The importance of the technological champion is well recognized among the management. However, as illustrated in Figure 4, this impact is not thought to be significant among the workers.

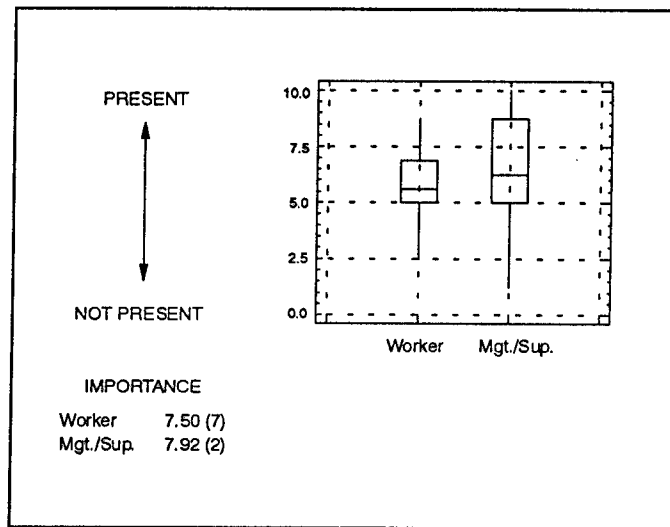

Figure 4: Air 1 Technological Champion

5.1.1.3 Worker Involvement in Planning and Selection. The workers indicated very consistently that their involvement in planning and selection is limited. Though a large variance is present among the management responses, fifty percent of the responses indicated a higher level of participation than the highest individual worker response. This difference clearly indicates a difference in perception of activity for this issue. As the third most important issue for both the workers and management, the impact of this issue is well recognized.

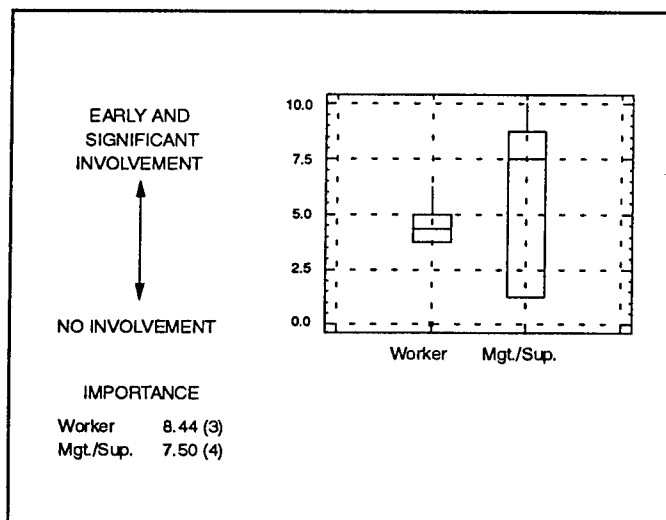

Figure 5: Air 1 Worker Involvement in Planning and Selection

5.1.1.4 Level of Introduction of Technology. Both the workers and management indicated that the company does not exclusively utilize either the pilot or the production-line approach. However, the importance of utilizing the pilot approach is clearly recognized.

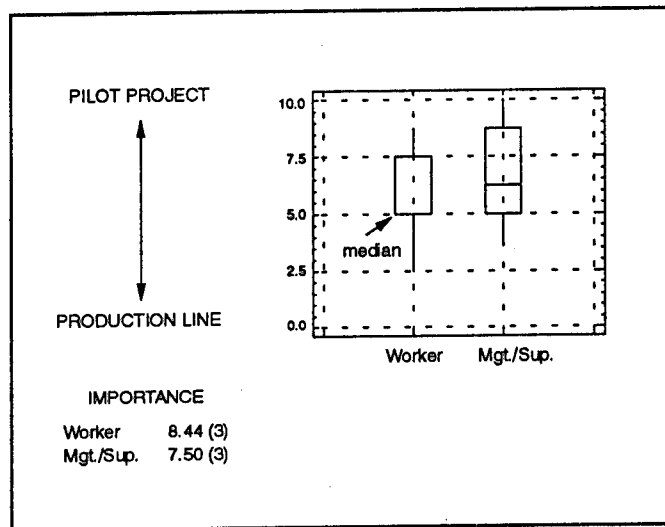

Figure 6: Air 1 Level of Introduction

5.1.1.5 Reorganization for New Technology. Both the workers and management provided consistent responses to the issue. The organization is perceived as utilizing team approaches to a limited degree. Both the workers and management think this issue is one of the most critical factors in a successful implementation.

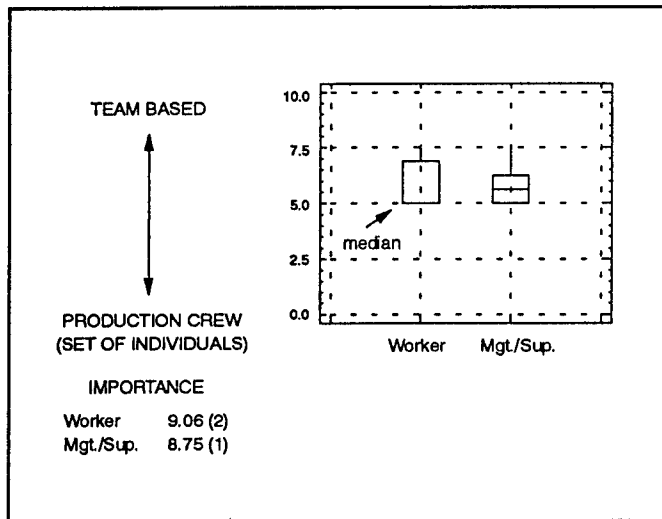

Figure 7: Air 1 Reorganization

5.1.1.6 New Demands in Skills, Knowledge, and Commitment. The workers who use technology-based systems consider themselves as only mildly more capable in terms of skills, knowledge, and commitment than workers who do not use new technology-based systems. The management group, however, responded that the production workers are much more capable in these areas. All groups considered the increased worker capability to be a significant issue for success.

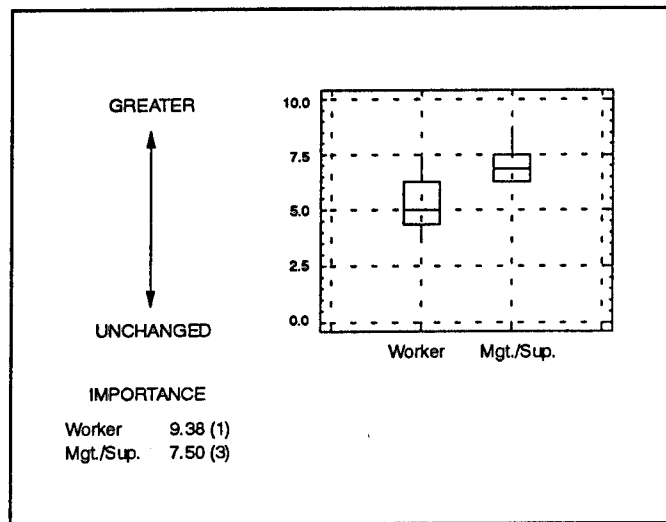

Figure 8: Air 1 New Demands on Workers

5.1.1.7 Reduction of Resistance to New Technology. Management responses indicated that substantial effort is directed toward the reduction of resistance to technology. Though these efforts are also recognized by the workers, they view them as somewhat less effective. Both groups agree that this issue has limited impact on success.

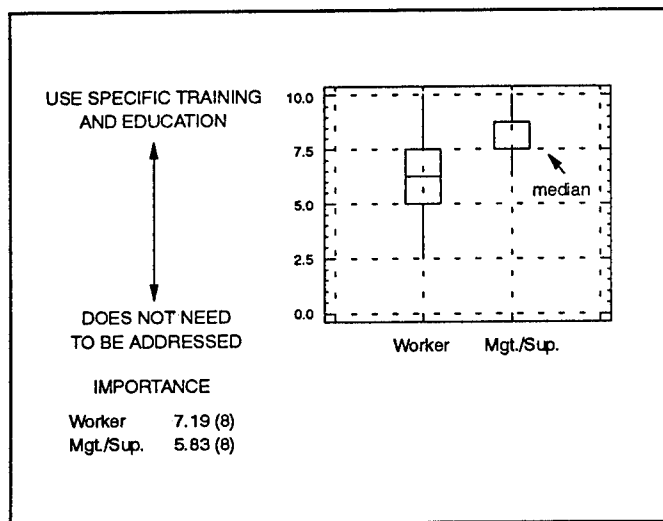

Figure 9: Air 1 Reduction of Resistance to New Technology

5.1.1.8 Performance Evaluation and Pay. Both the workers and management see only limited effort to adopt evaluation and pay procedures for new implementations. This issue was only of moderate importance to both the workers and management.

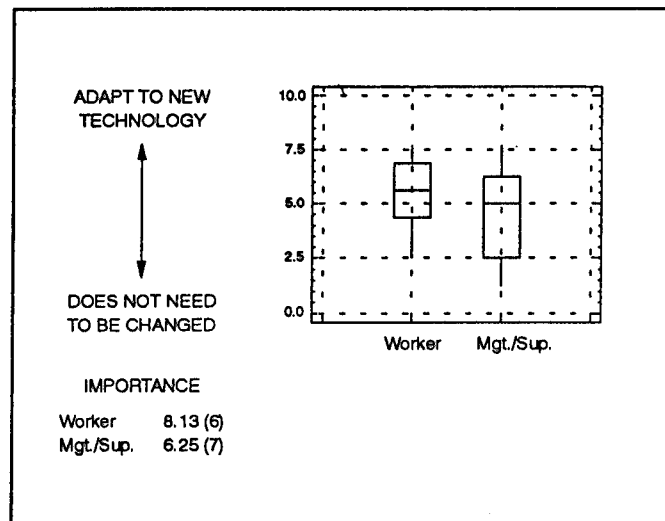

Figure 10: Air 1 Performance Evaluation and Pay

5.1.1.9 Decision Levels and Empowerment. Workers and management agree that only limited empowerment has accompanied the increased decision-making capabilities of the new technology. Empowerment was considered one of the least influential factors for success.

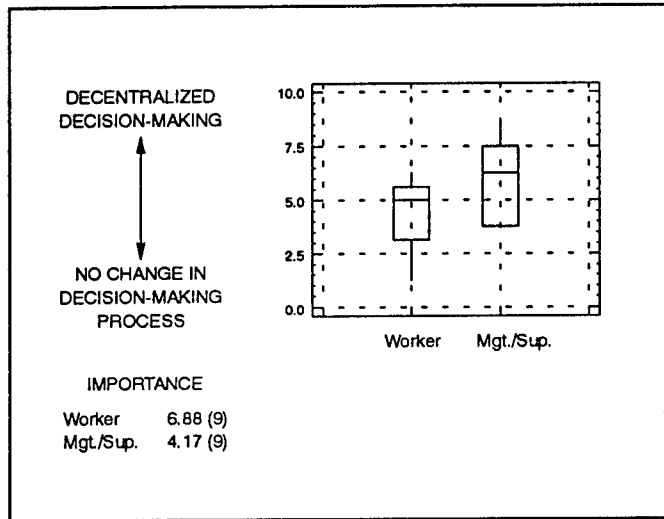

Figure 11: Air 1 Decision Levels and Empowerment

5.1.1.10 Success and Satisfaction with Implementation. The workers see only moderate success and satisfaction with technological implementations. Management responses reflect a much greater perception of success and satisfaction.

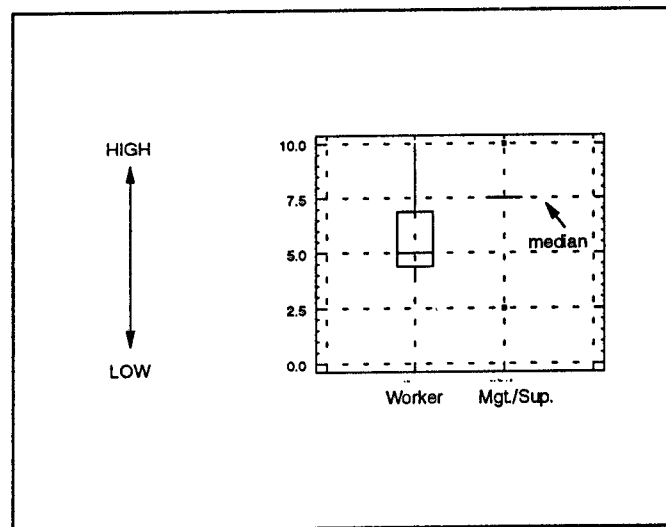

Figure 12: Air 1 Success and Satisfaction

5.1.2 Importance Rankings

Score Workers

- 9.38 New demands in skills, knowledge, and commitment.
- 9.06 Reorganization for new technology (teams).
- 8.44 Worker involvement in planning and selection.
- 8.44 Technological philosophy.
- 8.44 Level of introduction of new technology.
- 8.13 Performance evaluation and pay modification to suit new technology.
- 7.50 Technological champion.
- 7.19 Reduction of resistance to new technology with specific education and training efforts.
- 6.88 Lowered decision levels and increased empowerment.

Score Management and Supervisors

- 8.75 Reorganization for new technology (teams).
- 7.92 Technological champion.
- 7.50 New demands in skills, knowledge, and commitment.
- 7.50 Worker involvement in planning and selection.
- 7.50 Technological philosophy.
- 7.50 Level of introduction of new technology.
- 6.25 Performance evaluation and pay modification to suit new technology.
- 5.83 Reduction of resistance to new technology with specific education and training efforts.
- 4.17 Lowered decision levels and increased empowerment.

5.1.3 Representative Questionnaire Responses

This section is a summary of representative questionnaire responses. Responses are categorized by worker, management, and staff/engineer groups. While not providing quantitative data to each question, this section offers qualitative insight to the organizational human issues effort.

5.1.3.1 Planning, Selection, and Implementation Procedures

Workers	"...not involved..."
	"...upper management activity..."
Management/ Supervisors	"...performed by interdisciplinary teams..."

5.1.3.2 General Procedures and Level of Success

Workers	"...hands-on training..."
	"...mostly successful..."
Management/ Supervisors	"...both force-fed and developed through process improvement..."
	"...may have benefited from sponsor..."
	"...generally successful..."

5.1.3.3 Management Activity Changes with New Technology

Workers	"...little..."
	"...don't..."
	"...can't see any..."
Management/ Supervisors	"...started standing back..."
	"...enabler..."

"...better communication..."

"...more empowerment..."

5.1.3.4 Current Performance Measurement Methods

Workers	"...observation..."
	"...productivity, quality..."
Management/ Supervisors	"...goals..."
	"...productivity, quality..."

5.1.3.5 Desired Performance Measurement Methods

Workers	"...productivity, quality..."
Management/ Supervisors	"...current methods are adequate..."
	"...less cost and schedule conscious..."

5.1.3.6 Most Important Human Issues to Successful New Technology Implementations

Workers	"...training..."
	"...involvement..."
Management/ Supervisors	"...remove fears through training..."
	"...user participation, ownership..."

5.1.3.7 Personal Benefits From Effective Human Issue Programs

Workers	"...able to perform more effectively..."
Management/ Supervisors	"...less resistance..."
	"...spend more time doing job..."

5.1.3.8 Improving Quality of Work Life

Workers	"...better communication..."
	"...more decision-making..."
Management/ Supervisors	"...fewer meetings..."
	"...better communication..."
	"...less schedule conscious..."
	"...more training..."

5.1.3.9 Improving Personal Productivity

Workers	"...more support from other departments..."
	"...qualified trainers..."
Management/ Supervisors	"...cross-functional training..."

5.1.3.10 Additional Concerns

Workers	"...study is of new technology, not the worker..."
Management/ Supervisors	"...none..."

5.1.4 Improvement Strategy Pareto Chart

The following Pareto charts were developed, as specified in the Methods section of this report.

5.1.4.1 Worker Approach to Implementation Improvement. Worker responses indicate that human issue strategies for improving implementation success should concentrate on early and significant worker planning and selection of new technology, and the selection of more capable workers in skills, knowledge, and commitment.

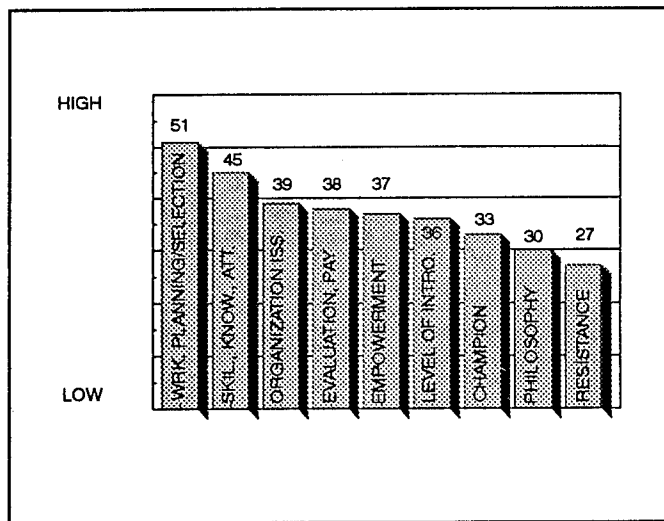

Figure 13: Air 1 Worker Approach to Implementation Improvement

5.1.4.2 Management and Supervisor Approach to Implementation Improvement. The management approach to implementation improvement differs significantly from that of the workers. The management approach would concentrate on team development and the modification of existing performance evaluation and pay systems.

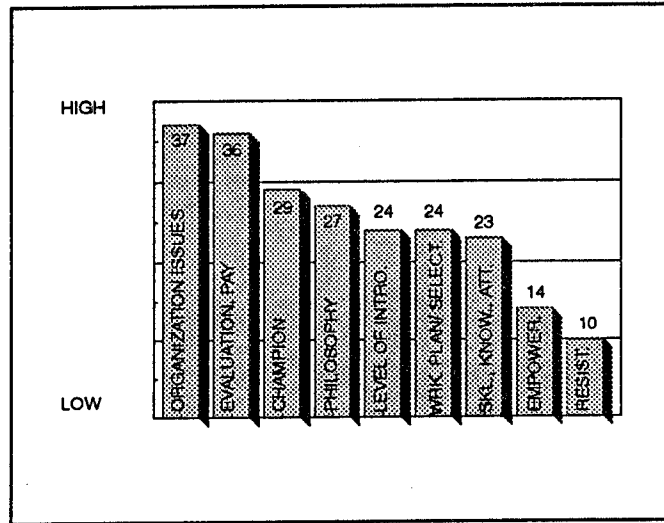

Figure 14: Air 1 Management / Supervisor Approach to Implementation Improvement

5.1.5 Assessment of Air 1 HITI practices

Though the workers consider the implementation efforts to be only mildly successful and satisfying, many individual Air 1 HITI efforts appear to be effective. Particular strength exists in the areas of technological philosophy and specific training and education to reduce resistance to new technology. Two issues which should be addressed are early and significant worker involvement in the planning and selection of new technology and the selection of workers to best meet the increased demands of new technology.

The currently limited, but important, worker involvement in planning and selection offers great opportunity for improving the implementation process. Similarly, large improvement is possible in worker selection, as workers see themselves as only somewhat more capable in skills, knowledge, and attitude than management and supervisors, but consider worker selection a very important factor for success.

One other area of interest is the universal desire for increased communication. In many cases, the management group perception of the level of activity for an issue was significantly higher than that of the workers.

In summary, Air 1 appears to have a cultural ambience where constructive dialogue leads to productivity and quality improvements. The comments made by the respondents tended to be respectful, reflecting a positive culture. On the balance, the company seems to be managed under a prevailing "Theory Y" style.

5.2 Air 2

The 22 September 1993 Air 2 site visit consisted of a series of general corporate and human modelling program briefings, a plant tour, and administration of the data collection packet. The plant tour included the wing and final assembly areas for the C-17. Administration of the data collection packet consisted of an orientation briefing and distribution of the packet. The following Air 2 employees completed the data collection packet.

- 13 Team Workers
 - 4 Supervisors/Facilitators
 - 1 Manufacturing Management Member
 - 6 Engineers
- 24 Total Participants

5.2.1 Survey Data Box and Whisker Plots

The following box and whisker plots were developed as specified in the Methods section of this report.

5.2.1.1 Technological Philosophy. Among the workers and management groups, the technological philosophy was considered to be between that of the computer-aided craftsman and the lights-out factory. The staff group, however, responded more strongly toward the craftsman end of the spectrum. The level of importance of the technological philosophy was considered of average importance among the workers and staff, while considered of lesser importance by management.

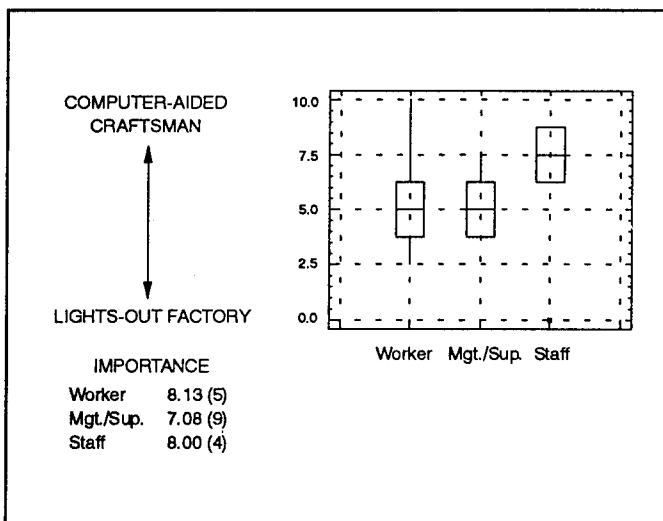

Figure 15: Air 2 Technological Philosophy

5.2.1.2 Technological Champion. Responses to the existence of the technological champion varied widely with the worker and management groups. All groups indicated only a mild presence of a technological champion, but also responded that the presence was very necessary for a successful implementation.

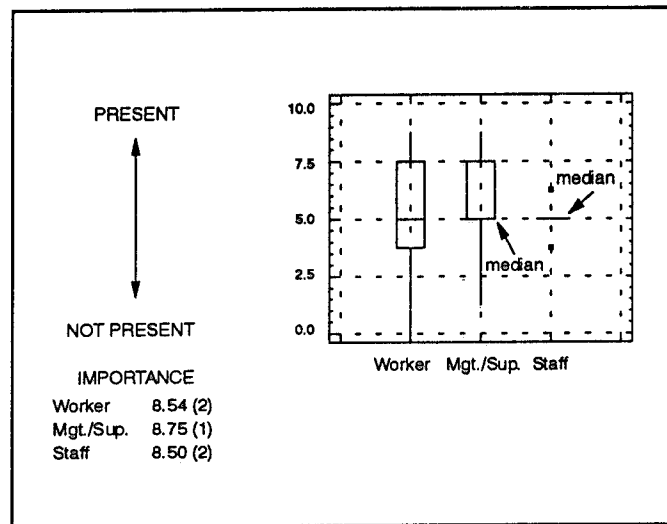

Figure 16: Air 2 Technological Champion

5.2.1.3 Worker Involvement in Planning and Selection. Though the worker response showed wide variance, the median response indicated that worker involvement is not present in the planning and selection of new technology. The management response indicated moderate involvement, while the staff response indicated strong involvement. While the workers apparently do not participate in this activity, they and the other groups believe that it is not of great importance.

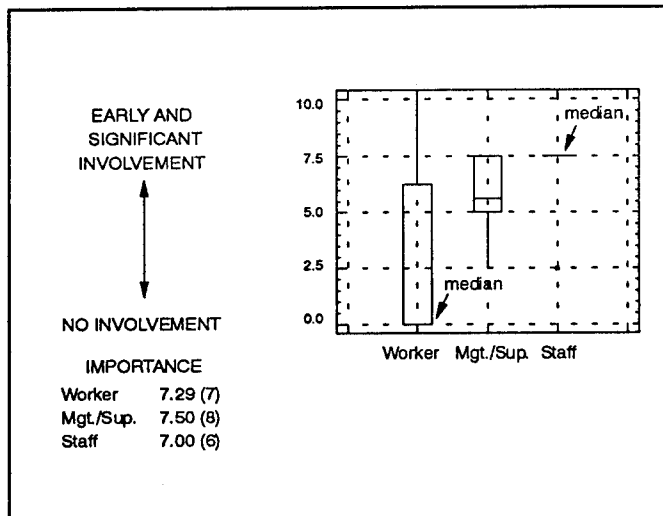

Figure 17: Air 2 Worker Involvement in Planning and Selection

5.2.1.4 Level of Introduction of Technology. All groups indicated that a combination pilot and production approach was utilized for the level of introduction of new technology. The importance of introduction with a pilot project was thought to be critical among all groups.

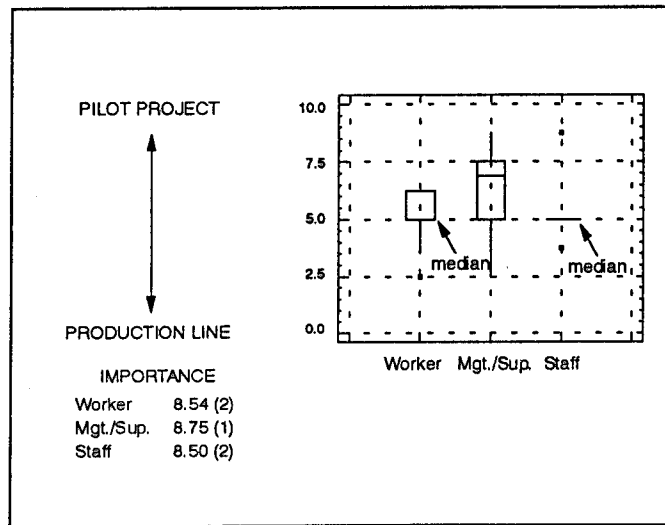

Figure 18: Air 2 Level of Introduction

5.2.1.5 Reorganization for New Technology. The worker and management groups indicated the existence of organization between team and production crew approaches. The staff believed that a more team-based approach was present, rather than a production crew approach. The workers and staff assigned moderate importance to the reorganization for new technology, while it was of greater importance for the management group.

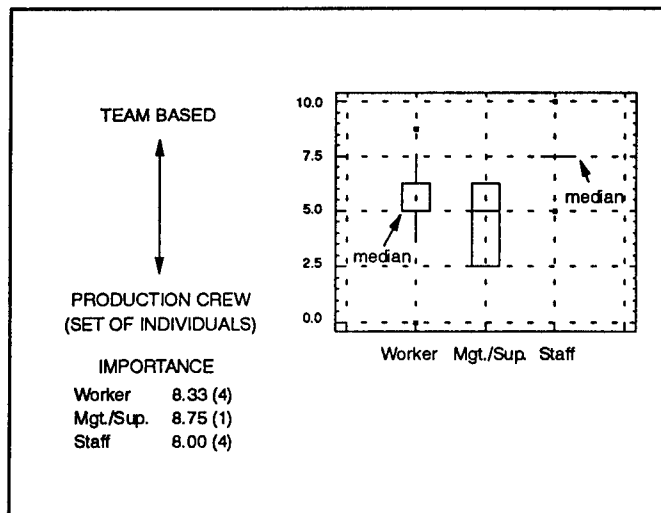

Figure 19: Air 2 Reorganization

5.2.1.6 New Demands in Skills, Knowledge, and Commitment.

Workers are seen as somewhat more capable in terms of skills, knowledge, and commitment. While among the workers and engineers these qualities are of great importance, they are of only moderate importance with the management.

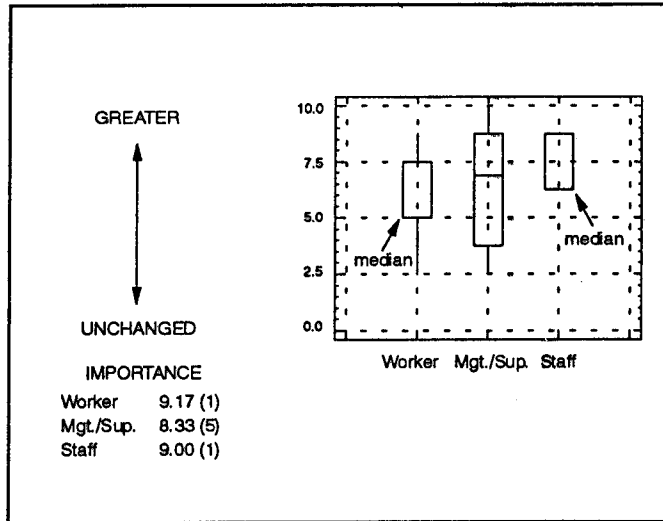

Figure 20: Air 2 New Demands on Workers

5.2.1.7 Reduction of Resistance to New Technology. The workers and management responded that some effort is being directed toward the reduction of resistance to new technology with implementation of special training and education programs. The staff group strongly disagreed, responding that little effort is being made. The workers and staff groups assigned lesser importance to this issue, while the management group believed that it has significant impact.

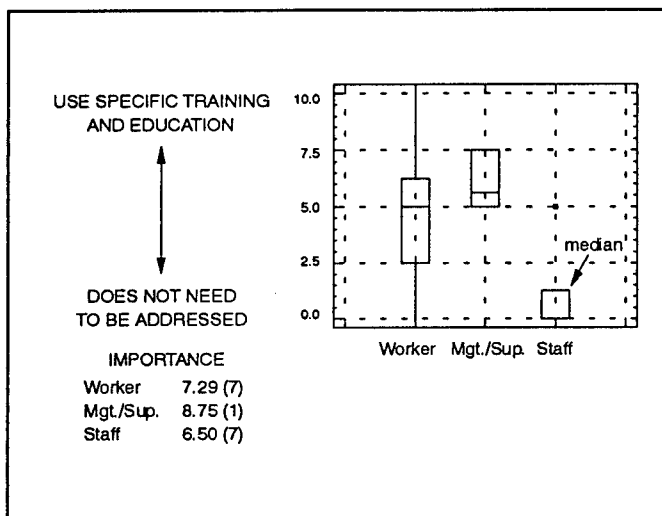

Figure 21: Air 2 Reduction of Resistance to New Technology

5.2.1.8 Performance Evaluation and Pay. All groups indicated mild efforts at modifying performance evaluation pay systems to suit the new technology. However, this issue was thought to be only of lesser importance.

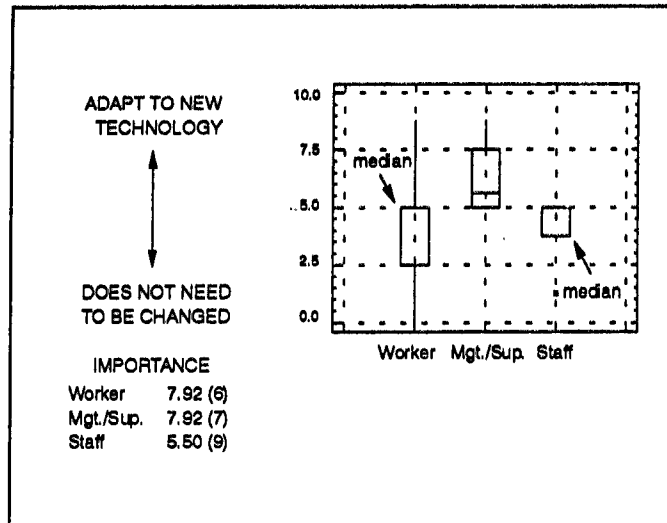

Figure 22: Air 2 Performance Evaluation and Pay

5.2.1.9 Decision Levels and Empowerment. All responses indicated that little change in decision-making processes has occurred with the increase of information capabilities of new technology systems. Of all groups, only the management thought this issue is of moderate importance to the success of an implementation.

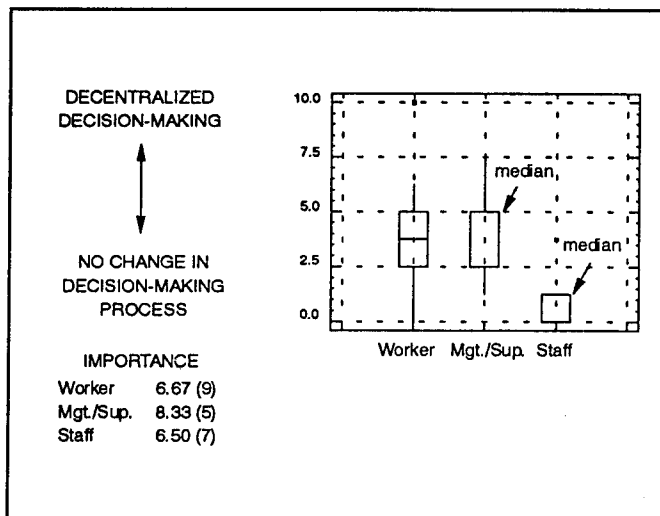

Figure 23: Air 2 Decision Levels and Empowerment

5.2.1.10 Success and Satisfaction with Implementation. The worker and management groups responded that the implementations were mildly successful. In contrast, the staff responses showed much less success and satisfaction.

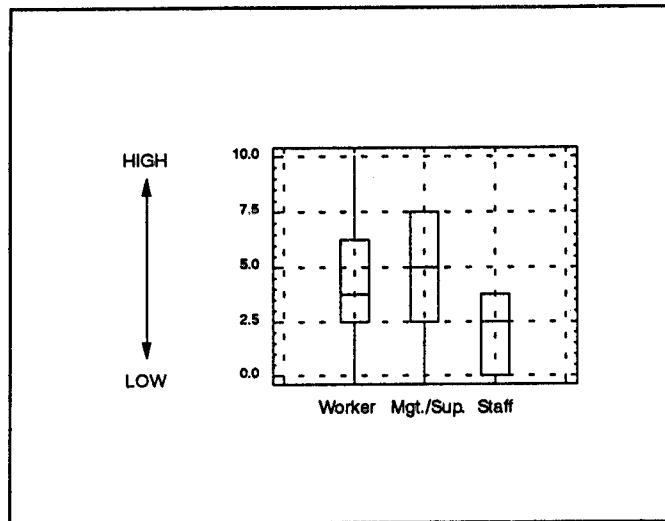

Figure 24: Air 2 Success and Satisfaction

5.2.2 Importance Rankings

Score Workers

- 9.17 New demands in skills, knowledge, and commitment.
- 8.54 Level of introduction of new technology.
- 8.54 Technological champion.
- 8.33 Reorganization for new technology (teams).
- 8.13 Technological philosophy.
- 7.92 Performance evaluation and pay modification to suit new technology.
- 7.29 Worker involvement in planning and selection.
- 7.29 Reduction of resistance to new technology with specific education and training efforts.
- 6.67 Lowered decision levels and increased empowerment.

Score Management/Supervisors

- 8.75 Level of introduction of new technology.
- 8.75 Technological champion.
- 8.75 Reorganization for new technology (teams).
- 8.75 Reduction of resistance to new technology with specific education and training efforts.
- 8.33 New demands in skills, knowledge, and commitment.
- 8.33 Lowered decision levels and increased empowerment.
- 7.92 Performance evaluation and pay modification to suit new technology.
- 7.50 Worker involvement in planning and selection.
- 7.08 Technological philosophy.

Score Staff (Engineers)

- 9.00 New demands in skills, knowledge, and commitment.
- 8.50 Level of introduction of new technology.
- 8.50 Technological champion.
- 8.00 Reorganization for new technology (teams).
- 8.00 Technological philosophy.
- 7.00 Worker involvement in planning and selection.
- 6.50 Reduction of resistance to new technology with specific education and training efforts.
- 6.50 Lowered decision levels and increased empowerment.
- 5.50 Performance evaluation and pay modification to suit new technology.

5.2.3 Representative Questionnaire Responses

This section is a summary of representative questionnaire responses. Responses are categorized by worker, management, and staff/engineer groups. While not providing quantitative data to each question, this section offers qualitative insight to organizational human issues effort.

5.2.3.1 Planning, Selection, and Implementation Procedures

Workers	"...very little production worker involvement..."
	"...not involved..."
Management/ Supervisors	"...manager and up..."
	"...upper management..."
Staff	"...management..."
	"...production engineering program..."

5.2.3.2 General Procedures and Level of Success

Workers	"...no training..."
	"...unsuccessful..."
Management/ Supervisors	"...some classes..."
	"...successful..."
Staff	"...limited by contract..."
	"...successful..."

5.2.3.3 Management Activity Changes with New Technology

Workers	"...no noticeable change..."
	"...not much..."

	"...no change..."
Management/ Supervisors	"...none..."
	"...no change..."
	"...failed to see the change..."
Staff	"...none..."

5.2.3.4 Current Performance Measurement Methods

Workers	"...productivity, quality..."
Management/ Supervisors	"...productivity, quality..."
Staff	"...meeting schedules..."

5.2.3.5 Desired Performance Measurement Methods

Workers	"...productivity, quality..."
Management/ Supervisors	"...quality first..."
Staff	"...productivity, quality..."

5.2.3.6 Most Important Human Issues to Successful New Technology Implementations

Workers	"...training..."
	"...worker input..."
Management/ Supervisors	"...involvement..."
Staff	"...training..."
	"...involvement..."

5.2.3.7 Personal Benefits From Effective Human Issue Programs

Workers	"...perform better..."
Management/ Supervisors	"...more enjoyable, relaxed environment..."
Staff	"...greater probability for success..."

5.2.3.8 Improving Quality of Work Life

Workers	"...training..."
	"...more reliable equipment..."
	"...recognition..."
Management/ Supervisors	"...give management authority..."
	"...more responsibility..."
Staff	"...improve morale..."
	"...better management support..."

5.2.3.9 Improving Personal Productivity

Workers	"...recognition..."
	"...change shift times..."
	"...access to information..."
Management/ Supervisors	"...elimination of unproductive activities..."
	"...greater participation..."
Staff	"...improve morale..."
	"...better management support..."

5.2.3.10 Additional Concerns

Workers	"...teach it, preach it, practice it..."
---------	--

Management/
Supervisors

"...company needs more discipline..."

Staff

"...Total Quality Management has failed..."

"...need to work on basic problems first..."

5.2.4 Improvement Strategy Pareto Charts

The following Pareto charts were developed, as specified in the Methods section of this report.

5.2.4.1 Worker Approach to Implementation Improvement. The worker approach to implementation improvement should concentrate on improving worker planning and selection of new technology. While implementation improvement is not considered to be one of the most important issues to success, so little activity is occurring that significant benefits can be realized.

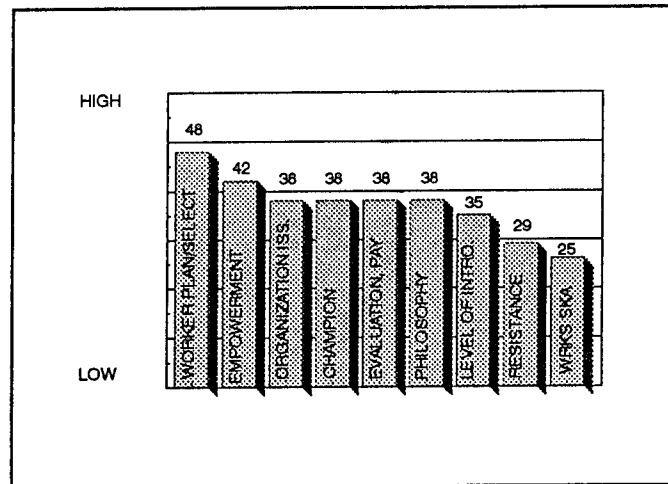

Figure 25: Air 2 Worker Approach to Implementation Improvement

5.2.4.2 Management and Supervisor Approach to Implementation Improvement. The management responses did not indicate issues which were of clearly more benefit than others. However, the presence of the worker planning and selection issue as the least beneficial in contrast to the worker approach indicated a clear difference of perception.

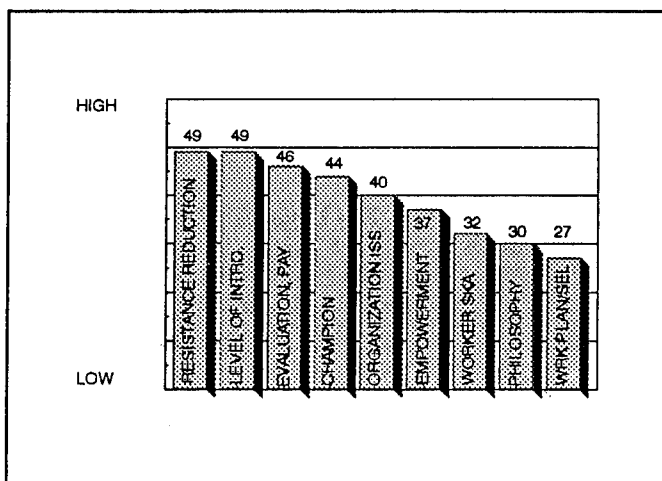

Figure 26: Air 2 Management / Supervisor Approach to Implementation Improvement

5.2.4.3 Staff Approach to Implementation Improvement. The staff/engineering group approach concentrates on the champion, empowerment, and reduction of resistance through education and training. As with the management approach, the staff group placed less benefit on worker planning and selection.

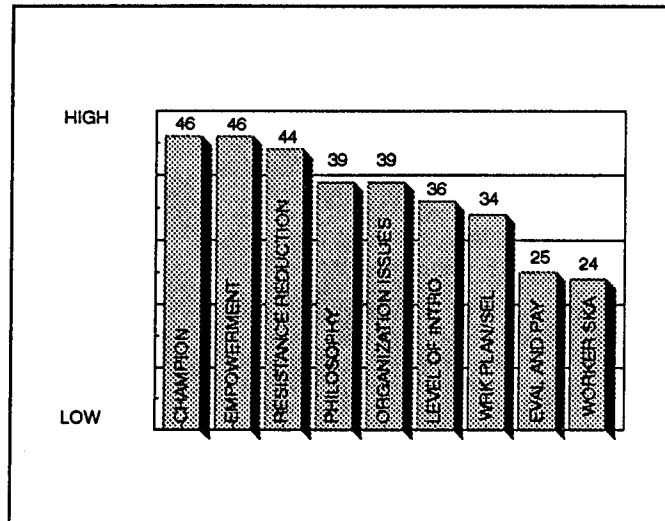

Figure 27: Air 2 Staff Approach to Implementation Improvement

5.2.5 Assessment of HITI Practices

Air 2 appears to have significant opportunity for improving HITI efforts. For all nine human issues, the median worker response was at or below 5.0. Particular areas demanding attention are the early and significant worker involvement in the planning and selection of new technology and worker decision levels and empowerment. In both issues, though the workers only saw limited importance in these areas, overall activity was so low that any improvement would yield significant benefits.

Another serious issue concerns the differences in staff / engineering responses and those of the workers and management. In spite of these differences, few questionnaire responses among any of the groups expressed a need for improved communication.

Many of the other representative questionnaire responses indicated the existence of morale problems at the company on the part of both the professionals and the workers.

As indicated by many individual human issue responses and the overall success and satisfaction responses, significant opportunity exists for improvement of Air 2 HITI efforts.

6.0 CONCLUSIONS

Section 3.0 identified nine human issues identified as critical in the success or failure of AMT implementations. A data collection packet, based on these issues, consisting of a survey and a questionnaire was developed to assess the effectiveness of organizational HITI efforts. The survey gathered data on the level of organizational HITI issue activity and the importance of that activity to successful implementations. The questionnaire gathered data on specific aspects of the organizational implementation process.

This packet was administered to two USAF airframe contractors in September 1993. Analysis of the data indicates that opportunity for improvement of the human issues in technology implementation is present in both organizations. Pareto analysis of both organizations indicates that the greatest opportunity exists in the area of early and significant worker participation in the planning and selection of new technology. Workers indicate that participation in the planning and selection of new technology occurred on only a limited basis and was of significant importance in the success and satisfaction of the implementation. This and other information obtained from the study was utilized to develop strategies for improving these contractors' organizational efforts in the human issues area.

The activity during Phase I of this research concentrated on the development of a means by which organizations can assess their human issues efforts in technology implementation. Organi-

zations can determine both the level of activity for a particular issue and the importance of that issue to implementation success. From this information, organizations can develop strategies for improving their human issues in technology implementation efforts.

While Phase I activity can be considered as a means by which organizations can determine what needs to be done to improve human issues efforts, it does not provide direct assistance in executing the improvements. Phase II activity, specified in the recommendations section of this report, will address how organizations may use this information to ultimately achieve improved manufacturing competitiveness.

7.0 RECOMMENDATIONS

This section presents recommendations for future deliverables and activity based on Phase I findings. It also includes a program plan for the creation of the HITRAIL and summarizes possible initial HITRAIL activities.

7.1 Phase II Human Issues in Technology Research, Application, and Implementation Laboratory

The Department of Industrial Engineering at the University of Pittsburgh has recently created a Manufacturing Assistance Center (MAC) in Pittsburgh, Pennsylvania. The overall mission of the MAC is to assist manufacturers with adopting the advanced manufacturing technology and training necessary to compete in the global market place. The HITRAIL is anticipated to function as one of the six laboratories constituting the MAC. As part of the MAC network, the HITRAIL will have the advantage of synergistically interacting with other MAC resources, as illustrated in Figure 28. This activity is expected to develop both academic and applied advances and lead to

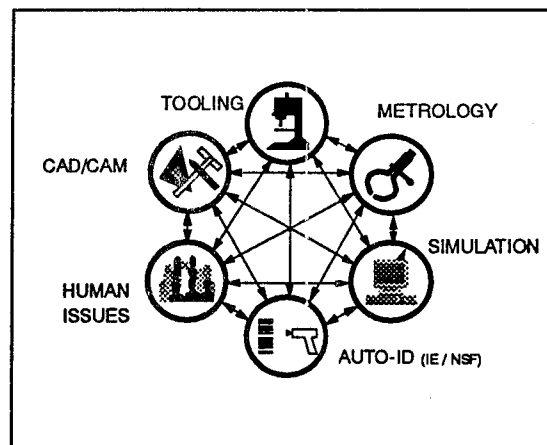
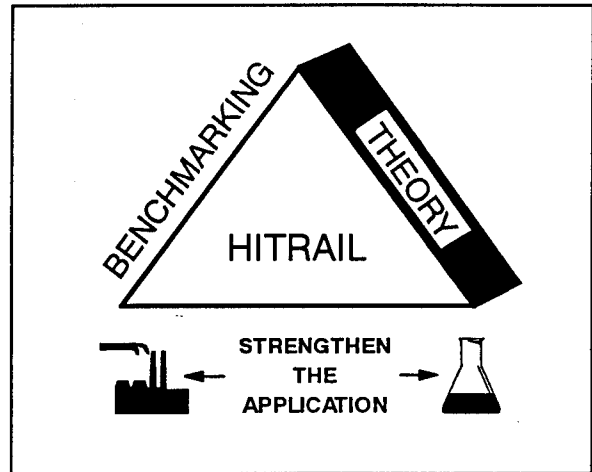

Figure 28: Synergistic
MAC Laboratory
Network

improved United States Air Force prime and subcontractor manufacturing competitiveness.

7.1.1 Concept

The operational concept of the proposed HITRAIL may be summarized by identifying the following mission, objectives, and strategies.



7.1.1.1 Mission. The mission of the HITRAIL is to assist in the improvement of United States Air Force prime and subcontractor manufacturing operations, ultimately leading to improved United States manufacturing competitiveness, as illustrated in Figure 29.

Figure 29: HITRAIL Mission

7.1.1.2 Objectives. The HITRAIL includes the following objectives.

- (1) Conduct benchmarking activities to search for and identify industry-best practices that lead to superior performance.
- (2) Conduct surveillance of ongoing research into human issues.
- (3) Extend the state of skills, knowledge, and attitudes in high-technology environments and strengthen the application of best practices (benchmarking) and theory to the real world.

- (4) Perform technology transfer through training, workshops, and publications.

7.1.1.3 Strategies. The mission of the HITRAIL will be accomplished through the use of the following strategies.

- (1) Leverage existing and planned MAC resources, including personnel, equipment, and real property.
- (2) Utilize the direct connection to the research resources of the University of Pittsburgh to ensure the continuous development of new human issues strategies.
- (3) Perform controlled intervention testing of HITI research and pilot projects. Initial activity in this area will address the nine HITI hypotheses, including philosophical approaches, planning, training, evaluation, and organizational design issues.
- (4) Utilize the well-developed knowledge transfer techniques currently being utilized by the MAC, including the use of technology transfer techniques such as those presented in the 1992 Summer MAC Workshops. This series covered subjects such as non-traditional manufacturing, quality, and team training for more than 400 registrations from 86 manufacturing organizations. Additional techniques include user consultations, technical papers, and other initiatives.

7.1.2 Additional Considerations

An evaluation of existing centers dealing with human issues indicates that the HITRAIL is unique in its direct relationship with both an actual manufacturing center and a major university. Several centers with a research focus exist in the United States; however, these organizations do not have direct access to a MAC facility that would allow the testing and refining of research findings. Similarly, many productivity-type centers, which focus only on support for manufacturing organiza-

tions, are in operation. These centers lack the research resources of a major university to drive the continuous and independent development of new human issues strategies.

7.2 Phase II Activities

Phase II of the research consists of a program plan for HITI based on the findings of Phase I research. This program includes the development of strategies for the application of the findings and learning gained during the literature review and site visits of the existing research. Phase II components include the HITI Assessment Tool, the HITI Management Simulator, and the HITI On-Line Data Base.

7.2.1 Human Issues in Technology Implementation Assessment Tool

The HITI Assessment Tool is a software package that will allow manufacturing organizations to determine the level of their HITI efforts and their ranking in comparison to both average and best-in-class organizations. The assessment tool will also have the capability to suggest strategies for improving manufacturing performance. Comparisons will be based on data obtained from ongoing HITI survey activities. This project is in the conceptual stage awaiting funding.

7.2.2 HITI Management Simulator

The HITI Management Simulator is based on the concept of learning by doing. Learning how to perform technological implementations by actual execution is an expensive, long-term process with potentially negative consequences. By using a personal computer to simulate the process of technological implementation, personnel (at the worker, staff, and supervisory level) can become familiar with and test various management strategies without consequence. The HITI management simulator is currently in development as a doctoral dissertation. The simulator will be Microsoft Windows-based and will offer a graphical, interactive means to assist organizations with their implementation efforts.

7.2.3 Human Issues in Technology Implementation On-Line Data Base

Information on human issues in new manufacturing technology implementations generated from traditional sources are often incomplete and require significant organizational effort. The MAC will generate and maintain the most extensive HITI data base in the United States. The HITI On-Line Data Base will provide real-time access to this valuable and topical information to participating organizations with Electronic Data Interchange.

REFERENCES

1. Majchrzak, Ann, The Human Side of Factory Automation, San Francisco: Jossey-Bass, 1988.
2. Saraph, Jayant V. and Sebastian, Richard J., "Human Resource Strategies for Effective Introduction of Advanced Manufacturing Technologies," Production and Inventory Management Journal, First Quarter 1992, Vol. 33, No. 1, pp. 64-70.
3. Ettl, J. E., "Facing the Factory of the Future," Managing Technological Innovation: Organizational Strategies for Implementing Advanced Manufacturing Technologies, D. D. Davis (ed.), San Francisco: Jossey-Bass, 1986.
4. Teresko, John, "America's Best Plants," Industry Week, October 21, 1991, Vol. 240, No. 20, pp. 19, 32.
5. Cole, Robert, "U.S. Quality Improvement in the Auto Industry: Close but No Cigar," California Management Review, Summer 1990, Vol. 32, No. 4, pp. 71-85.
6. Moskal, Brian S., "The Wizards of Buick City," Industry Week, May 7, 1990, Vol. 239, No. 9, pp. 22-28.
7. Majchrzak, Ann, The Human Side of Factory Automation, San Francisco: Jossey-Bass, 1988, pp. 1-18.
8. Rennels, Kenneth E., "Human Factor Aspects of Implementing New Technologies," Proceedings of the 1990 International Industrial Engineering Conference, San Francisco, May 20-23, 1990, pp. 318-322.
9. Ettkin, Lawrence P., Helms, Marilyn M., and Haynes, Paula J., "People: A Critical Element of New Technology Implementation," Industrial Management, September/October 1990, Vol. 32, No. 5, pp. 27-29.
10. Hornsby, H. Heyward and Williams, C. Glyn, "CAM Still Needs People," Business and Economic Review, October/December 1990, Vol. 37, No. 1, pp. 26-30.
11. Office of Technology Assessment, Computerized Manufacturing Automation, Library of Congress No. 84-601053, Washington, D.C.: Government Printing Office, 1984.
12. Ebel, Karl H., "Manning the Unmanned Factory," International Labour Review, 1989, Vol. 128, No. 5, pp. 535-551.

13. Badham, Richard J., "The Social Dimensions of Computer-Integrated Manufacturing," International Labour Review, Vol. 130, No. 3, pp. 373-392.
14. Corbett, J. Martin, "Human-centred Advanced Manufacturing Systems: From Rhetoric to Reality," International Journal of Industrial Ergonomics, January 1990, Vol. 5, No. 1, pp. 83-90.
15. Flynn, Patricia, Facilitating Technological Change, Cambridge, MA: L Ballinger Publishing Co., 1988.
16. Corbett, J. Martin, "Human-centred Advanced Manufacturing Systems: From Rhetoric to Reality," International Journal of Industrial Ergonomics, January 1990, Vol. 5, No. 1, pp. 83-90.
17. Badham, Richard, "Human-centred CIM," Futures, December 1991, Vol. 23, No. 10, pp. 1047-1060.
18. Ibid.
19. Tippet, Donald D., "Technology Implementation Management," Proceedings of the Second International Conference on Engineering Management, Toronto, Sept. 10-13, 1989, pp. 135-139.
20. Derven, Marjorie., "Sell Technology Internally," Personnel Journal, April 1990, Vol. 69, No. 4, pp. 32-37.
21. Gupta, Yash P., "Human Aspects of Flexible Manufacturing Systems," Production & Inventory Management, Second Quarter 1989, Vol. 30, No. 2, pp. 30-36.
22. Rennels, Kenneth E., "Human Factor Aspects of Implementing New Technologies," Proceedings of the 1990 International Industrial Engineering Conference, San Francisco, May 20-23, 1990, pp. 318-323.
23. Hurst, Blaine F., "Facilitating Change," CIO Journal, Spring 1991, Vol. 3, No. 4, pp. 39-46.
24. Chew, W. Bruce, Leonard-Barton, Dorothy, and Bohn, Roger E., "Beating Murphy's Law," Sloan Management Review, Vol. 32, No. 3, Spring 1991, pp. 5-16.
25. O'Brien, Jean P. and Kroggel, Lawrence P., Jr., "Technology: Training not Trauma," Personnel Journal, August 1989, Vol. 68, No. 8, pp. 32-41.
26. Etkin, Lawrence P., Helms, Marilyn M., and Haynes, Paula J., "People: A Critical Element of New Technology Implementation," Industrial Management, September/October 1990, Vol. 32, No. 5, pp. 27-29.

27. O'Brien, Jean P. and Kroggel, Lawrence P., Jr., "Technology: Training not Trauma," Personnel Journal, August 1989, Vol. 68, No. 8, pp. 32-41.
28. Gupta, Yash P., "Human Aspects of Flexible Manufacturing Systems," Production & Inventory Management, Second Quarter 1989, Vol. 30, No. 2, pp. 30-36.
29. Kulmann, Torsten M., "Adapting to Technical Change in the Workplace," Personnel, Aug 1988, Vol. 65, No. 8, pp. 67-69.
30. Rennels, Kenneth E., "Human Factor Aspects of Implementing New Technologies," Proceedings of the 1990 International Industrial Engineering Conference, San Francisco, May 20-23, 1990, pp. 318-322.
31. Alter, Allan, "CIM: The Human Element Anxiety Attacks," CIO, January 1989, Vol. 2, No. 4, pp. 28-33.
32. Beatty, Carol, "Implementing Advanced Manufacturing Technologies: Rules of the Road," Sloan Management Review, Vol. 33, No. 4, Summer 1992, pp. 49-60.
33. Beatty, Carol, "Implementing Advanced Manufacturing Technology," Business Quarterly, Autumn 1990, Vol. 54, No. 6, pp. 46-50.
34. Beatty, Carol, "Critical Implementation Decisions For Advanced Manufacturing Technologies," Proceedings of the OMA-UK International Conference, Birmingham, England, 25-26 June 1991, pp. 187-192.
35. Beatty, Carol A. and Gordon, John R., "Advanced Manufacturing Technology: Making It Happen," Business Quarterly, Spring 1990, Vol. 54, No. 4, pp. 46-54.
36. Beatty, Carol A. and Gordon, John R.M., "Preaching the Gospel: The Evangelists of New Technology," California Management Review, Spring 1991, Vol. 33, No. 3, pp. 73-94.
37. Norman, Ronald J. and Corbitt, Gail F., "A Cure for Technology Implementation Headaches," Chief Information Officer Journal, Spring 1991, pp. 35-38.
38. Hornsby, H. Heyward and Williams, C. Glyn, "CAM Still Needs People," Business and Economic Review, Oct-Dec 1990, Vol. 37, No. 1, pp. 26-30.
39. Ebel, Karl H., "Manning the Unmanned Factory," International Labour Review, 1989, Vol. 128, No. 5, pp. 535-551.
40. Andreichuk, Brian, "Getting Objective About Quality," Small Business Reports, March 1992, Vol. 17, No. 3, pp. 28-38.

41. Goldhar, Joel D., and Jelinek, Mariann, "Manufacturing as a Service Business, CIM in the 21st Century," Computers in Industry, May 1990, Vol. 14, No. 1-3, pp. 225-245.
42. Bessant, John and Buckingham, Joanna, "Implementing Integrated Technology," Technovation, July 1989, Vol. 9, No. 4, pp. 321-334.
43. Gupta, Yash P., "Human Aspects of Flexible Manufacturing Systems," Production & Inventory Management, Second Quarter 1989, Vol. 30, No. 2, pp. 30-36.
44. Helfgott, R.B., "Can U.S. Industrial Workers Handle Advanced Technology?" Proceedings Worker in Transition: Technological Change Conference, Bethesda, MD, April 4-7, 1989, pp. 263-270.
45. Oliver, Nick, "Human Factors in the Implementation of JIT Production," International Journal of Operations and Production Management, 1990, Vol. 10, No. 4, pp. 32-40.
46. O'Brien, Jean P. and Kroggel, Lawrence P., Jr., "Technology: Training not Trauma," Personnel Journal, August 1989, Vol. 68, No. 8, pp. 32-41.
47. Ettkin, Lawrence P., Helms, Marilyn M., and Haynes, Paula J., "People: A Critical Element of New Technology Implementation," Industrial Management, September/October 1990, Vol. 32, No. 5, pp. 27-29.
48. "Managing People and the Technology," Industry Week, July 2, 1990, Vol. 239, No. 13, ccl0.
49. Nota, B. C., "Conditions for Successful Organizational Responses to Technological Change," Proceedings Worker in Transition: Technological Change Conference, Bethesda, MD. April 4-7, 1989, pp. 63-68.
50. Wesler, M. and Fought, J., "Computerization and Workplace Interaction," Proceedings Worker in Transition: Technological Change Conference, Bethesda, MD. April 4-7, 1989, pp. 29-34.
51. Tobias, Andrew M., "Managing the Redesign of Manufacturing Systems," International Journal of Technology Management, 1991, Vol. 6, No. 3/4, pp. 375-384.
52. Ettkin, Lawrence P., Helms, Marilyn M., and Haynes, Paula J., "People: A Critical Element of New Technology Implementation," Industrial Management, September/October 1990, Vol. 32, No. 5, pp. 27-29.

53. Kuhlmann, Torsten M., "Adapting to Technical Change in the Workplace," Personnel, Aug 1988, Vol. 65, No. 8, pp. 67-69.
54. Bessant, John, and Buckingham, Joanna, "Implementing Integrated Technology," Technovation, July 1989, Vol. 9, No. 4, pp. 321-334.
55. "Managing People and the Technology," Industry Week, July 2, 1990, Vol. 239, No. 13, cc10.
56. Hornsby, H. Heyward, and Williams, C. Glyn, "CAM Still Needs People," Business and Economic Review, Oct-Dec 1990, Vol. 37, No. 1, pp. 26-30.
57. Rennels, Kenneth E., "Human Factor Aspects of Implementing New Technologies," Proceedings of the 1990 International Industrial Engineering Conference, San Francisco, May 20-23, 1990, pp. 318-322.
58. Helfgott, R.B., "Can U.S. Industrial Workers Handle Advanced Technology?" Proceedings Worker in Transition: Technological Change Conference, Bethesda, MD, April 4-7, 1989, pp. 263-270.
59. Rennels, Kenneth E., "Human Factor Aspects of Implementing New Technologies," Proceedings of the 1990 International Industrial Engineering Conference, San Francisco, May 20-23, 1990, pp. 318-322.
60. Helfgott, R.B., "Can U.S. Industrial Workers Handle Advanced Technology?" Proceedings Worker in Transition: Technological Change Conference, Bethesda, MD, April 4-7, 1989, pp. 263-270.
61. Ross, David F., "Aligning the Organization for World-Class Manufacturing," Production and Inventory Management Journal, Second Quarter, 1991, Vol. 32, No. 2, pp. 22-26.
62. Hayes, Robert H., and Jaikumar, Ramchandran, "Requirements for Successful Implementation of New Manufacturing Technologies," Journal of Engineering and Technology Management, Vol. 7, No. 3-4, March 1991, pp. 169-175.
63. Alter, Allan, "CIM: The Human Element Anxiety Attacks," CIO, January 1989, Vol. 2, No. 4, pp. 28-33.
64. Hornsby, H. Heyward and Williams, C. Glyn, "CAM Still Needs People," Business and Economic Review, Oct-Dec 1990, Vol. 37, No. 1, pp. 26-30.
65. Recardo, Ronald J., "Appropriate Reward Systems for JIT Processes," Journal for Quality and Participation, Dec 1990, pp. 30-36.

66. Adler, Paul S., "Workers and Flexible Manufacturing Systems: Three Installations Compared," Journal of Organizational Behavior, Vol. 12, No. 5, pp. 447-460.
67. Johnson, Thomas W. and Manoochehri, G. H., "Adopting JIT: Implications for Worker Roles and Human Resource Management," Industrial Management, May-June 1990, Vol. 32, No. 3, pp. 2-6.
68. Bessant, John, and Buckingham, Joanna, "Implementing Integrated Technology," Technovation, July 1989, Vol. 9, No. 4, pp. 321-334.
69. Helfgott, R.B., "Can U.S. Industrial Workers Handle Advanced Technology?" Proceedings Worker in Transition: Technological Change Conference, Bethesda, MD, April 4-7, 1989, pp. 263-270.
70. Ross, David F., "Aligning the Organization for World-Class Manufacturing," Production and Inventory Management Journal, Second Quarter, 1991, Vol. 32, No. 2, pp. 22-26.
71. Martin, Tomas, "The Need for Human Skills in Production - The Case of CIM," Computers in Industry, May 1990, Vol. 14, No. 1-3, pp. 205-211.
72. Hayes, Robert H., and Jaikumar, Ramchandran, "Requirements for Successful Implementation of New Manufacturing Technologies," Journal of Engineering and Technology Management, Vol. 7, No. 3-4, March 1991, pp. 169-175.
73. Beatty, Carol, "Implementing Advanced Manufacturing Technologies: Rules of the Road," Sloan Management Review, Vol. 33, No. 4, Summer 1992, pp. 49-60.
74. Ebel, Karl H., "Manning the Unmanned Factory," International Labour Review, 1989, Vol. 128, No. 5, pp. 535-551.
75. Bessant, John, and Buckingham, Joanna, "Implementing Integrated Technology," Technovation, July 1989, Vol. 9, No. 4, pp. 321-334.
76. Badham, Richard, "Human-Centred CIM," Futures, Dec 1991, Vol. 23, No. 10, pp. 1047-1060.
77. Parden, Robert J., "Facilitated Technology Training," Proceedings Second International Conference on Engineering Management, Toronto, Sept. 10-13, 1989, pp. 237-241.
78. Bessant, John, and Buckingham, Joanna, "Implementing Integrated Technology," Technovation, July 1989, Vol. 9, No. 4, pp. 321-334.

79. Altany, David, "Lead Now or Forever Rest in Peace," Industry Week, April 17, 1989, Vol. 238, No. 8, pp. 16-17.
80. Gupta, Yash P., "Human Aspects of Flexible Manufacturing Systems," Production & Inventory Management, Second Quarter 1989, Vol. 30, No. 1, pp. 30-36.
81. Ettlle, J. E., "Facing the Factory of the Future," Managing Technological Innovation: Organizational Strategies for Implementing Advanced Manufacturing Technologies, D. D. Davis (ed.), San Francisco: Jossey-Bass, 1986.
82. Jaikumar, Ramchandran, "Post Industrial Manufacturing," Harvard Business Review, November/December 1986, Vol. 64, No. 6, pp. 69-75.
83. Uzumeri, Vic and Walsh, Susan, "Buying Advanced Manufacturing Technology," Manufacturing Engineering, Vol. 105, No. 2, August 1990, pp. 11-15.
84. Freeman, Mark and Beale, Peter, "Measuring Project Success," Project Management Journal, March 1992, Vol. 23, No. 1, pp. 8-17.
85. Gibson, James L., Ivancevich, John M., and Donnelly, James H., Organizations, Homewood, IL: Irwin, 1991.

APPENDIX A

**USAF
HUMAN ISSUES
IN
TECHNOLOGY IMPLEMENTATION**

DATA COLLECTION PACKET

UNIVERSITY OF PITTSBURGH



MANUFACTURING ASSISTANCE CENTER

PRINCIPAL INVESTIGATORS

Dr. David I. Cleland
Dr. Bopaya Bidanda

RESEARCH ASSISTANT

Mr. Christopher A. Chung

**UNIVERSITY OF PITTSBURGH
DEPARTMENT OF INDUSTRIAL ENGINEERING
MANUFACTURING ASSISTANCE CENTER
1072 BENEDUM HALL
PITTSBURGH, PA 15261
(412)-624-9848**

HUMAN ISSUES IN TECHNOLOGY IMPLEMENTATION

THE OBJECTIVE OF THIS STUDY:

We are hoping to gather information from leading manufacturing companies in the United States on "human - oriented" issues that are important when adopting new technologies on the shop floor. We believe that in most manufacturing companies, the focus is primarily on technology; people who work with this technology are often not considered as a factor. By considering these issues, we hope to improve both your company's performance and U.S. manufacturing competitiveness.

SPONSORS OF THE STUDY:

United States Air Force Armstrong Laboratory, Wright-Patterson AFB, OH
University of Pittsburgh, Department of Industrial Engineering

PARTICIPANTS IN THE STUDY:

Boeing
McDonnell-Douglas
Motorola
Northrop
Packard Electric

HOW WILL THIS STUDY BENEFIT YOU?

The results of this study will help your company understand your attitudes. This in turn will make the company more responsive to your needs when adopting new technologies on the shop floor. The company will be provided with a list of factors that you believe is important. The results of the study will also detail how company policies can be adapted so that new technologies can be more successfully implemented on the shop floor.

GENERAL INSTRUCTIONS:

Please answer all questions based on your experience with your current work group which uses new technology. New technology is defined as computerized or automated equipment (hardware and software).

Your specific responses will be kept confidential and the questions are designed so that you cannot be individually identified.

PART A - PARTICIPANT PROFILE

INTRODUCTION: This form collects a variety of participant profile data which will be used with the data obtained in Part B - Survey and Part C - Questionnaire. This will assist in determining if relationships exist between Human Issues in Technology Implementation perceptions and participant profiles.

INSTRUCTIONS: Please circle or complete each question. If more than one category applies, circle as many categories as is necessary.

- | | | | | | | |
|---|--------------|----------------------------|----------------------------|--------------|-------------------------|----------------|
| 1. Group | team worker | non-team worker | supervisor/
facilitator | mfg.
mgt. | mfg.
staff
(eng.) | other
_____ |
| 2. Total years employed by this company | less than 1 | 1-4 | 5-9 | 10-14 | 15-19 | 20+ |
| 3. Age | less than 20 | 20-29 | 30-39 | 40-49 | 50-59 | 60+ |
| 4. Gender | female | male | | | | |
| 5. Education | high school | associate/
trade school | bachelors's | master's | doctoral | |
| 6. Please list the type and number of hours of any specialized training which you have received which relates to new technology or work philosophies. | | | | | | |

PART A - PARTICIPANT PROFILE

INTRODUCTION: This form collects a variety of participant profile data which will be used with the data obtained in Part B - Survey and Part C - Questionnaire. This will assist in determining if relationships exist between Human Issues in Technology Implementation perceptions and participant profiles.

INSTRUCTIONS: Please circle or complete each question. If more than one category applies, circle as many categories as is necessary.

- | | | | | | | |
|---|--------------|----------------------------|----------------------------|--------------|-------------------------|----------------|
| 1. Group | team worker | non-team worker | supervisor/
facilitator | mfg.
mgt. | mfg.
staff
(eng.) | other
_____ |
| 2. Total years employed by this company | less than 1 | 1-4 | 5-9 | 10-14 | 15-19 | 20+ |
| 3. Age | less than 20 | 20-29 | 30-39 | 40-49 | 50-59 | 60+ |
| 4. Gender | female | male | | | | |
| 5. Education | high school | associate/
trade school | bachelors's | master's | doctoral | |
6. Please list the type and number of hours of any specialized training which you have received which relates to new technology or work philosophies.

PART B - SURVEY

INTRODUCTION: This survey determines your views of various concepts concerning how your work group operates with respect to human issues in the implementation of new technology.

INSTRUCTIONS: Darken the circle which most closely reflects your views.

		STRONGLY DISAGREE	MILDLY DISAGREE	NEUTRAL OR NOT APPLICABLE	MILDLY AGREE	STRONGLY AGREE
1.	New technology is present mainly to support your efforts in your daily work.	<input type="radio"/>	<input type="radio"/>	<input type="radio"/>	<input type="radio"/>	<input type="radio"/>
2.	You are given the opportunity to participate in the planning and selection of new technology prior to installation.	<input type="radio"/>	<input type="radio"/>	<input type="radio"/>	<input type="radio"/>	<input type="radio"/>
3.	You have little control over new technology which you use in your daily work.	<input type="radio"/>	<input type="radio"/>	<input type="radio"/>	<input type="radio"/>	<input type="radio"/>
4.	Your views and experience are considered valuable input when planning and selecting new technology.	<input type="radio"/>	<input type="radio"/>	<input type="radio"/>	<input type="radio"/>	<input type="radio"/>
5.	New technology is always introduced directly into a production line.	<input type="radio"/>	<input type="radio"/>	<input type="radio"/>	<input type="radio"/>	<input type="radio"/>
6.	We always have a high level management individual(s) who provides strong and continuous encouragement when we adopt new technology.	<input type="radio"/>	<input type="radio"/>	<input type="radio"/>	<input type="radio"/>	<input type="radio"/>
7.	We always introduce new technology with a small pilot project on a test basis.	<input type="radio"/>	<input type="radio"/>	<input type="radio"/>	<input type="radio"/>	<input type="radio"/>
8.	People who use our new technology must have more skills, greater knowledge, and additional commitment than before.	<input type="radio"/>	<input type="radio"/>	<input type="radio"/>	<input type="radio"/>	<input type="radio"/>
9.	We can successfully adopt new technology even if there is no one who is particularly interested in making sure that it works.	<input type="radio"/>	<input type="radio"/>	<input type="radio"/>	<input type="radio"/>	<input type="radio"/>

PART B - SURVEY continued

		STRONGLY DISAGREE					
		MILDLY DISAGREE					
		NEUTRAL OR NOT APPLICABLE					
		MILDLY AGREE					
		STRONGLY AGREE					
10.	Changing from large production crews to other types of work arrangements is not necessary when we adopt new technology.	→	<input type="radio"/>	<input type="radio"/>	<input type="radio"/>	<input type="radio"/>	<input type="radio"/>
11.	Our new technology does not generally place additional demands on the capabilities or efforts of the workers.	→	<input type="radio"/>	<input type="radio"/>	<input type="radio"/>	<input type="radio"/>	<input type="radio"/>
12.	Decision making empowerment is given to the people at the lowest level where the necessary information is available.	→	<input type="radio"/>	<input type="radio"/>	<input type="radio"/>	<input type="radio"/>	<input type="radio"/>
13.	We typically use special training and educational programs to help reduce the resistance to new technology.	→	<input type="radio"/>	<input type="radio"/>	<input type="radio"/>	<input type="radio"/>	<input type="radio"/>
14.	When new technology is utilized, we modify the performance evaluation and pay systems.	→	<input type="radio"/>	<input type="radio"/>	<input type="radio"/>	<input type="radio"/>	<input type="radio"/>
15.	New types of work arrangements, such as small teams of cross-trained workers are absolutely necessary when we adopt new technology.	→	<input type="radio"/>	<input type="radio"/>	<input type="radio"/>	<input type="radio"/>	<input type="radio"/>
16.	The same people at the same level are still empowered to make all the decisions regardless of the level of technology that is present.	→	<input type="radio"/>	<input type="radio"/>	<input type="radio"/>	<input type="radio"/>	<input type="radio"/>
17.	We do not utilize any special training or educational programs to help reduce resistance to the introduction of new technology.	→	<input type="radio"/>	<input type="radio"/>	<input type="radio"/>	<input type="radio"/>	<input type="radio"/>
18.	We have no reason to change performance evaluation and pay systems when we adopt new technology.	→	<input type="radio"/>	<input type="radio"/>	<input type="radio"/>	<input type="radio"/>	<input type="radio"/>
19.	We are generally very successful in introducing and utilizing new technology.	→	<input type="radio"/>	<input type="radio"/>	<input type="radio"/>	<input type="radio"/>	<input type="radio"/>
20.	I am personally satisfied with the way we adopt new technology.	→	<input type="radio"/>	<input type="radio"/>	<input type="radio"/>	<input type="radio"/>	<input type="radio"/>

PART B - SURVEY continued

INTRODUCTION: This survey determines the level of importance that you place on various concepts concerning human Issues in the implementation of new technology.

INSTRUCTIONS: Darken the circle which most closely reflects your views.

		NO IMPORTANCE					
		LESSER IMPORTANCE			AVERAGE IMPORTANCE		
		GREATER IMPORTANCE		EXTREME IMPORTANCE			
1.	Consideration for the strengths and weaknesses of human workers when adopting and operating new technology is of ...	→	<input type="radio"/>	<input type="radio"/>	<input type="radio"/>	<input type="radio"/>	<input type="radio"/>
2.	The level of worker participation in the planning and selection of new technology is of ...	→	<input type="radio"/>	<input type="radio"/>	<input type="radio"/>	<input type="radio"/>	<input type="radio"/>
3.	Introduction of new technology on a scale which will allow testing and worker familiarization prior to full scale implementation is of ...	→	<input type="radio"/>	<input type="radio"/>	<input type="radio"/>	<input type="radio"/>	<input type="radio"/>
4.	The presence of a high level individual in the company to provide encouragement and support when adopting new technology is of ...	→	<input type="radio"/>	<input type="radio"/>	<input type="radio"/>	<input type="radio"/>	<input type="radio"/>
5.	The level of skills, knowledge, and commitment of the workforce to best utilize new technology is of ...	→	<input type="radio"/>	<input type="radio"/>	<input type="radio"/>	<input type="radio"/>	<input type="radio"/>
6.	The use of special training and educational programs to help reduce fears and resistance to new technology is of ...	→	<input type="radio"/>	<input type="radio"/>	<input type="radio"/>	<input type="radio"/>	<input type="radio"/>
7.	Changing performance evaluation and pay systems to suit the new technology is of ...	→	<input type="radio"/>	<input type="radio"/>	<input type="radio"/>	<input type="radio"/>	<input type="radio"/>
8.	Restructuring work force arrangements to suit the new technology is of ...	→	<input type="radio"/>	<input type="radio"/>	<input type="radio"/>	<input type="radio"/>	<input type="radio"/>
9.	Lowering the levels at which decisions are made, to improve flexibility and responsiveness made possible by new technology is of ...	→	<input type="radio"/>	<input type="radio"/>	<input type="radio"/>	<input type="radio"/>	<input type="radio"/>
10.	Being able to provide input and participate in this survey is of ...	→	<input type="radio"/>	<input type="radio"/>	<input type="radio"/>	<input type="radio"/>	<input type="radio"/>

END OF SURVEY

APPENDIX B

PART C - QUESTIONNAIRE

PREAMBLE: This questionnaire collects specific information on current and desired operational policies which are related to Human Issues in Technology Implementation. This specifically provides you with the opportunity to comment on policies which would enhance and be beneficial to your daily operations.

INSTRUCTIONS: Please provide a brief answer to the following questions:

1. Briefly describe the procedures that your organization utilizes for the:
 - a) the planning of new technology.
 - b) the selection of new technology.
 - c) the implementation of new technology.

2. What things has your organization done when introducing new technology? Do you think the attempts were successful or unsuccessful?

3. How have management activities changed in your organization as a result of the introduction of new technology?

4. How is your performance measured? (for example in productivity, quality, and other areas)

5. How would you like your performance to be measured? (for example in productivity, quality, and other areas)

6. What do you consider to be the most important human issues in a successful new technology implementation?

7. How do you think you would personally benefit from an effective human issues technology implementation program, such as the one you described in question 6?

8. What can be done to improve the quality of your work life?

9. What can be done to improve your individual productivity?

10. Please express any additional concerns which you have, which have not been discussed, in any of the preceding questions.