

FINAL REPORT
SEPTEMBER 1994

REPORT NO. EVT 18-90

155MM METAL FIELD ARTILLERY
PROJECTILE PALLET (FAPP)
FIRST ARTICLE TESTING (FAT)

DTIC
ELECTE
MAR 14 1995
S G D

Prepared for:
U.S. Army Armament Research, Development
and Engineering Center
ATTN: SMCAR-AEP
Picatinny Arsenal, NJ 07806-5000

Distribution Unlimited

19950309 092

VALIDATION ENGINEERING DIVISION
SAVANNA, ILLINOIS 61074-9639

U.S. ARMY
ARMAMENT
MUNITIONS
CHEMICAL COMMAND

U.S. ARMY DEFENSE AMMUNITION
CENTER AND SCHOOL

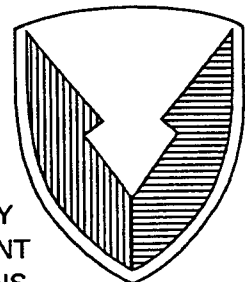

AVAILABILITY NOTICE

A copy of this report will be furnished each attendee on automatic distribution. Additional copies or authority for reprinting may be obtained by written request from Director, U.S. Army Defense Ammunition Center and School, ATTN: SMCAC-DEV, Savanna, IL 61074-9639.

DISTRIBUTION INSTRUCTIONS

Destroy this report when no longer needed. Do not return.

Citation of trade names in this report does not constitute an official endorsement.

The information contained herein will not be used for advertising purposes.

REPORT DOCUMENTATION PAGE				Form Approved OMB No. 0704-0188	
1a. REPORT SECURITY CLASSIFICATION UNCLASSIFIED			1b. RESTRICTIVE MARKINGS		
2a. SECURITY CLASSIFICATION AUTHORITY		3. DISTRIBUTION / AVAILABILITY OF REPORT UNLIMITED			
2b. DECLASSIFICATION / DOWNGRADING SCHEDULE					
4. PERFORMING ORGANIZATION REPORT NUMBER(S) EVT 18-90			5. MONITORING ORGANIZATION REPORT NUMBER(S)		
6a. NAME OF PERFORMING ORGANIZATION U.S. Army Defense Ammunition Center and School		6b. OFFICE SYMBOL <i>(if applicable)</i> SMCAC-DEV	7a. NAME OF MONITORING ORGANIZATION		
6c. ADDRESS <i>(City, State, and ZIP Code)</i> ATTN: SMCAC-DEV Savanna, IL 61074-9639			7b. ADDRESS <i>(City, State, and ZIP Code)</i>		
8a. NAME OF FUNDING / SPONSORING ORGANIZATION U.S. Army Armament Research, Development and Engineering Center		8b. OFFICE SYMBOL <i>(if applicable)</i> SMCAR-AEP	9. PROCUREMENT INSTRUMENT IDENTIFICATION NUMBER		
8c. ADDRESS <i>(City, State, and ZIP Code)</i> ATTN: SMCAR-AEP Picatinny Arsenal, NJ 07806-5000			10. SOURCE OF FUNDING NUMBERS		
			PROGRAM ELEMENT NO.	PROJECT NO.	TASK NO.
			WORK UNIT ACCESSION NO.		
11. TITLE <i>(Include Security Classification)</i> 155MM Metal Field Artillery Projectile Pallet (FAPP) First Article Testing (FAT)					
12. PERSONAL AUTHOR(S) William R. Meyer					
13a. TYPE OF REPORT Final		13b. TIME COVERED FROM _____ TO _____		14. DATE OF REPORT <i>(Year, Month, Day)</i> 1994 September	15. PAGE COUNT
16. SUPPLEMENTARY NOTATION					
17. COSATI CODES			18. SUBJECT TERMS <i>(Continue on reverse if necessary and identify by block number)</i>		
FIELD	GROUP	SUB-GROUP			
19. ABSTRACT <i>(Continue on reverse if necessary and identify by block number)</i> The U.S. Army Defense Ammunition Center and School (USADACS), Validation Engineering Division (SMCAC-DEV), was tasked by the U.S. Army Armament Research, Development and Engineering Center (ARDEC) to conduct MIL-STD-1660 and rail impact tests on the 155mm Field Artillery Projection Pallet (FAPP). This report contains test results with the 155mm FAPP meeting MIL-STD-1660, Design Criteria for Ammunition Unit Loads, and rail impact testing requirements.					
20. DISTRIBUTION / AVAILABILITY OF ABSTRACT <input checked="" type="checkbox"/> UNCLASSIFIED/UNLIMITED <input type="checkbox"/> SAME AS RPT. <input type="checkbox"/> DTIC USERS			21. ABSTRACT SECURITY CLASSIFICATION UNCLASSIFIED		
22a. NAME OF RESPONSIBLE INDIVIDUAL JEROME H. KROHN			22b. TELEPHONE <i>(Include Area Code)</i> 815-273-8929	22c. OFFICE SYMBOL SMCAC-DEV	

U.S. ARMY DEFENSE AMMUNITION CENTER AND SCHOOL
VALIDATION ENGINEERING DIVISION
SAVANNA, IL 61074-9639

REPORT NO. EVT 18-90

155MM METAL FIELD ARTILLERY PROJECTILE PALLET (FAPP)
FIRST ARTICLE TESTING (FAT)

TABLE OF CONTENTS

PART	PAGE NO.
1. INTRODUCTION	1-1
A. BACKGROUND	1-1
B. AUTHORITY	1-1
C. OBJECTIVE	1-1
D. CONCLUSION	1-1
2. ATTENDEES	2-1
3. TEST PROCEDURES	3-1
4. TEST EQUIPMENT	4-1
5. TEST RESULTS	5-1
6. PHOTOGRAPHS	6-1
7. GRAPHS	7-1
8. DRAWING	8-1

PART 1

INTRODUCTION

A. BACKGROUND. The U.S. Army Defense Ammunition Center and School (USADACS), Validation Engineering Division (SMCAC-DEV), was tasked by the U.S. Army Armament Research, Development and Engineering Center (ARDEC) to conduct MIL-STD-1660 and rail impact testing on the 155mm metal Field Artillery Projectile Pallet (FAPP).

B. AUTHORITY. This test was conducted IAW mission responsibilities delegated by the U.S. Army Armament, Munitions and Chemical Command (AMCCOM), Rock Island, IL.

C. OBJECTIVE. The objective of this test was to ascertain that the projectile and the 155mm FAPP would not be damaged during transportation.

D. CONCLUSION. The 155mm FAPP completed MIL-STD-1660 and rail impact testing with no damage occurring to the ammunition. Only minor dents occurred to the FAPP, which completed testing in a reusable condition. This design passed MIL-STD-1660, Design Criteria for Ammunition Unit Loads, and rail impact testing.

Accession For	
NTIS	CRA&I <input checked="" type="checkbox"/>
DTIC	TAB <input type="checkbox"/>
Unannounced <input type="checkbox"/>	
Justification	
By	
Distribution /	
Availability Codes	
Dist	Avail and/or Special
A-1	

PART 2

17 AUGUST 1994

ATTENDEES

William R. Meyer
General Engineer
DSN 585-8090
815-273-8090

Director
U.S. Army Defense Ammunition Center
and School
ATTN: SMCAC-DEV
Savanna, IL 61074-9639

Jerome H. Krohn
Supervisory General Engineer
DSN 585-8908
815-273-8908

Director
U.S. Army Defense Ammunition Center
and School
ATTN: SMCAC-DEV
Savanna, IL 61074-9639

Quinn D. Hartman
General Engineer
DSN 585-8992
815-273-8992

Director
U.S. Army Defense Ammunition Center
and School
ATTN: SMCAC-DEV
Savanna, IL 61074-9639

Bradley J. Haas
Mechanical Engineer
DSN 585-8336
815-273-8336

Director
U.S. Army Defense Ammunition Center
and School
ATTN: SMCAC-DEV
Savanna, IL 61074-9639

David V. Valant
Electronics Technician
DSN 585-8988
815-273-8988

Director
U.S. Army Defense Ammunition Center
and School
ATTN: SMCAC-DEV
Savanna, IL 61074-9639

Thomas J. Michels
Supervisory General Engineer
DSN 585-8080
815-273-8080

Director
U.S. Army Defense Ammunition Center
and School
ATTN: SMCAC-DES
Savanna, IL 61074-9639

Sandra Schultz
Industrial Engineer
DSN 585-8086
815-273-8086

Director
U.S. Army Defense Ammunition Center
and School
ATTN: SMCAC-DES
Savanna, IL 61074-9639

William R. Frerichs
Supervisory General Engineer
DSN 585-8071
815-273-8071

Director
U.S. Army Defense Ammunition Center
and School
ATTN: SMCAC-DET
Savanna, IL 61074-9639

Ralph A. Arnold
Industrial Engineering Technician
DSN 585-8073
815-273-8073

Director
U. S. Army Defense Ammunition Center
and School
ATTN: SMCAC-DET
Savanna, IL 61074-9639

Richard S. Haynes
Industrial Engineering Technician
DSN 585-8225
815-273-8225

Director
U. S. Army Defense Ammunition Center
and School
ATTN: SMCAC-DET
Savanna, IL 61074-9639

Dan Healy
Senior Inspector
708-392-6846
202-828-1999

Association of American Railroads
Bureau of Explosives
309 N. Douglas
Arlington Heights, IL 60004

Mark Rehmstedt
DSN 793-8206
309-782-8206

Commander
U.S. Army Armament Research,
Development and Engineering Center
ATTN: SMCAR-ESK
Rock Island, IL 61299-7300

Brandon Wehe
DSN 793-3894
309-782-3894

Commander
U.S. Army Armament, Munitions and
Chemical Command
ATTN: AMSMC-ASN-N
Rock Island, IL 61299-6000

Joseph Menke
DSN 793-3065
309-782-3065

Commander
U.S. Army Armament Research,
Development and Engineering Center
ATTN: SMCAR-ESM-H
Rock Island, IL 61299-7300

Jeff Gollor
309-793-4081

Nomura Enterprise, Incorporated
2832 Fifth Street
Rock Island, IL 61201

Mark L. Dawson
309-793-4081

Nomura Enterprise, Incorporated
2832 Fifth Street
Rock Island, IL 61201

Alvin Lew
DSN 880-2906
201-724-2906

Commander
U.S. Army Armament Research,
Development and Engineering Center
ATTN: SMCAR-AEP
Picatinny Arsenal, NJ 07806-5000

James R. Gray
DSN 793-6740
309-782-6740

Office of the Project Manager
Ammunition Logistics
ATTN: AMCPM-AL (R)
Rock Island, IL 61299-6000

PART 3

TEST PROCEDURES

A. The test procedures outlined in this section were extracted from MIL-STD-1660, Design Criteria for Ammunition Unit Loads, 8 April 1977. This standard identifies nine steps that a unitized load must undergo if it is to be considered acceptable. The four tests that were conducted on the test pallets are summarized below.

1. STACKING TESTS. The unit load was loaded to simulate a stack of identical unit loads stacked 16 feet high, for a period of one hour. This stacking load is simulated by subjecting the unit load to a compression weight equal to an equivalent 16-foot stacking height. The compression load is calculated in the following manner. The unit load weight is divided by the unit load height in inches and multiplied by 192. The resulting number is the equivalent compressive force of a 16-foot-high load.

2. REPETITIVE SHOCK TEST. The repetitive shock test was conducted IAW Method 5019, Federal Standard 101. The test procedure is as follows. The test specimen was placed on, but not fastened to, the platform. With the specimen in one position, the platform vibrated at 1/2-inch amplitude (1-inch double amplitude) starting at a frequency of approximately 3 cycles-per-second. The frequency was steadily increased until the package left the platform. The resonant frequency is achieved when a 1/16-inch-thick feeler gage may be momentarily slid freely between every point on the specimen in contact with the platform at some instance during the cycle or a platform acceleration achieves 1 ± 0.1 G. Midway into the testing period, the specimen was rotated 90 degrees and the test continued for the duration. Unless failure occurs, the total time of vibration is two hours, if the specimen is tested in one position, and three hours for more than one position.

3. EDGEWISE ROTATIONAL DROP TEST. This test was conducted using the procedures of Method 5008, Federal Standard 101. The procedure for the edgewise rotational drop test is as follows. The specimen was placed on its skids with one end of the pallet supported on a beam 4-1/2-inches high. The height of the beam was increased, when necessary, to ensure there was no support for the skids between the ends of the pallet when dropping took place, but was not high enough to cause the pallet to slide on the supports when the dropped end was raised for the drops. The unsupported end of the pallet was then raised and allowed to fall freely to the concrete, pavement, or similar underlying surface from a prescribed height. Unless otherwise specified, the height of drop for level A protection conforms to the following tabulation.

GROSS WEIGHT NOT EXCEEDING (Pounds)	DIMENSIONS ON ANY EDGE NOT EXCEEDING (Inches)	HEIGHT OF DROP LEVEL A PROTECTION (Inches)
600	72	36
3,000	no limit	24
no limit	no limit	12

4. INCLINE-IMPACT TEST. This test was conducted using the procedure of Method 5023, Incline-Impact Test of Federal Standard 101. The procedure for the incline-impact test is as follows: The specimen was placed on the carriage with the surface or edge being impacted projecting at least 2 inches beyond the front end of the carriage. The carriage was brought to a predetermined position on the incline and released. If it is desired to concentrate the impact on any particular position on the container, a 4- by 4-inch timber may be attached to the bumper in the desired position before the test. No part of the timber was struck by the carriage. The position of the container on the carriage and the sequence in which surfaces and edges are

subjected to impacts are at the option of the testing activity and depend upon the objective of the tests. This test is to determine satisfactory requirements for a container or pack, and, unless otherwise specified, the specimen was subjected to one impact on each surface that has each dimension less than 9.5 feet. Unless otherwise specified, the velocity at time of impact was 7 feet-per-second.

B. Rail impact tests were also conducted. These test procedures were extracted from Transportability Testing Procedures, TP-94-01, July 1994.

1. RAIL IMPACT TEST. A total of 39 pallets of 155mm ammunition were loaded into a railcar with the blocking and bracing placed as shown in part 8. The weight and load configuration was identical to that of live ammunition. Equipment needed to perform the test included the specimen (hammer) car, five empty railroad cars connected together to serve as the anvil, and a railroad locomotive. These anvil cars were positioned on a level section of track with air and hand brakes set and with the draft gear compressed. The locomotive unit pulled the specimen car several hundred yards away from the anvil cars and, then, pushed the specimen car toward the anvil at a predetermined speed, then disconnected from the specimen car approximately 50 yards away from the anvil cars, which allowed the specimen car to roll freely along the track until it struck the anvil. This constituted an impact. Impacting was accomplished at speeds of 4, 6, and 8 mph in one direction and at a speed of 8 mph in the opposite direction. The 4 and 6 mph impact speeds are approximate; the 8 mph speed is a minimum. Impact speeds were determined using an electronic counter to measure the time required for the specimen car to traverse an 11-foot distance immediately prior to contact with the anvil cars (see figure 1). At the discretion of the test engineer, additional impacts at higher or lower speeds may be conducted on the specimen car for engineering test data after the conclusion of the four required rail impacts.

2. DATA COLLECTION. The specimen car was instrumented with accelerometers at the following locations:

- (a) On the sill of the railcar.
- (b) At the top of the test load on each end and in the center.
- (c) On the coupler of the first anvil car.

Additionally, six load cells were placed between separator gates. After each rail impact, the accelerometers were downloaded to determine stresses, load forces, and accelerations during each impact. Data collected are suitable for use in investigating causes for failure as well as design criteria when developing new procedures, if required.

3. FAILURE CRITERIA. Following each impact, the load was examined for excessive shifting of contents, loosening or breaking of load restraints or blocking and bracing, or any visible damage to the items in the load or their packaging. Normally, testing is stopped when it becomes apparent that the load will fail; however, the test may be continued until complete failure if the test engineer determines usable data will be developed and safety of personnel and equipment integrity is not violated.

**ASSOCIATION OF AMERICAN RAILROADS (AAR)
STANDARD TEST PLAN**

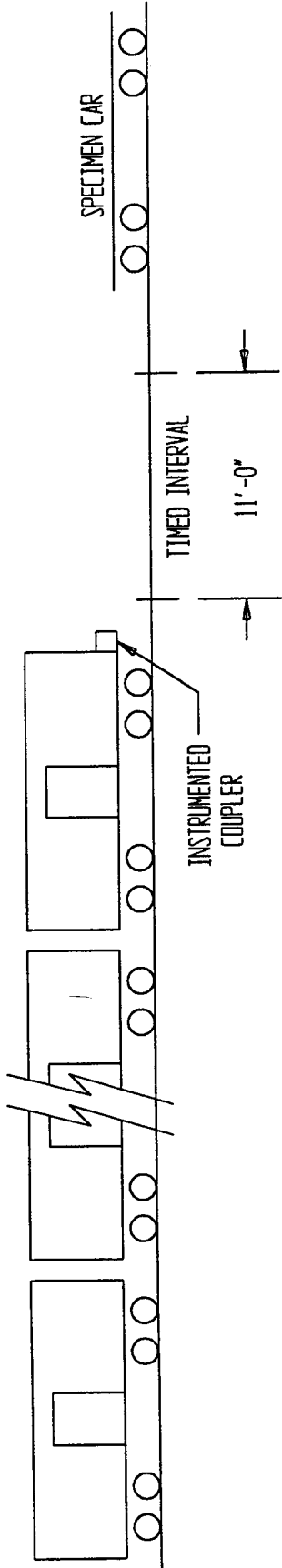
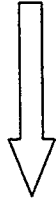

5 BUFFER CARS (ANVIL) WITH DRAFT GEAR
COMPRESSED AND AIR BRAKES IN A SET
POSITION
ANVIL CARS TOTAL WT 250,000 LBS (APPROX)

SPECIMEN CAR
IS RELEASED BY
SWITCH ENGINE TO
ATTAIN: IMPACT NO. 1 @ 4 MPH
IMPACT NO. 2 @ 6 MPH
IMPACT NO. 3 @ 8 MPH
THEN THE CAR IS REVERSED AND
RELEASED BY SWITCH ENGINE TO
ATTAIN: IMPACT NO 4. @ 8 MPH

FIGURE 1

PART 4

TEST EQUIPMENT

A. 155mm FAPP.

- | | |
|---------------------------|--------------------|
| 1. Drawing Number: | 19-48-4012-5PE1000 |
| 2. Width: | 29-1/8 inches |
| 3. Length: | 14-3/4 inches |
| 4. Height: | 39 inches |
| 5. Weight Loaded (155mm): | 928 pounds |

B. Compression Tester.

- | | |
|-----------------------|----------------------|
| 1. Manufacturer: | Ormond Manufacturing |
| 2. Platform: | 60- by 60-inches |
| 3. Compression Limit: | 50,000 pounds |
| 4. Tension Limit: | 50,000 pounds |

C. Transportation Simulator.

- | | |
|------------------|--------------------|
| 1. Manufacturer: | Gaynes Laboratory |
| 2. Capacity: | 6,000-pound pallet |
| 3. Displacement: | 1/2-inch amplitude |
| 4. Speed: | 50 to 400 rpm |
| 5. Platform: | 5- by 8-foot |

D. Inclined Plane.

- | | |
|------------------|--------------------|
| 1. Manufacturer: | Conbur Incline |
| 2. Type: | Impact Tester |
| 3. Grade: | 10 percent incline |
| 4. Length: | 12 foot |

E. Railcar.

1. Car Number:	RBOX 38569
2. Car Type:	Boxcar
3. Length:	50 feet (approximately)
4. Width:	10 feet (approximately)
5. Weight:	154,000 pounds
6. Draft Gear:	Friction

F. Data Acquisition Equipment.

1. Manufacturer:	Pacific Scientific
2. Number of channels:	14

PART 5

TEST RESULTS

A. STACKING TEST. The FAPP was initially loaded to 4,650 pounds compression. The compression was released after one hour. No damage was noted during this test.

B. REPETITIVE SHOCK TEST. The duration of the test was 90 minutes for each orientation of the pallet. For the lateral orientation, the transportation simulator was initially set for 150 rpm until clearance appeared between the pallet and the transportation simulator bed, then decreased to 115 rpm. No damage was noted. The transportation simulator was set for 130 rpm with the pallet in the longitudinal orientation. One of the lifting rings worked loose during this orientation. Also, the plastic protective ring of one round was damaged by the forklift tine while pushing the pallet onto the vibration table.

C. EDGEWISE ROTATIONAL DROP TEST. Each side of the pallet was placed on a beam displacing it 4-1/2-inches above the floor. The opposite end of the pallet was raised to a height of nearly 18 inches, then dropped. A height of 18 inches was employed instead of the specified 24 inches due to the dimensions of the pallet. After each side had been dropped, two additional lifting rings had loosened.

D. INCLINE-IMPACT TEST. The inclined plane was set to allow the pallets to travel 8 feet prior to impacting a stationary wall. The pallet was rotated clockwise after each impact, until all four sides had been tested. No damage was noted.

E. END OF TEST INSPECTION. Two of the three lifting rings that became loose during the tests were able to be retightened, the third remained loose. No other damage was noted.

F. RAIL IMPACT TEST. A total of 12 FAPPs were tested, 3 at each end and 6 at the center gates. Wooden pallets were used at the other locations to fill out the load. Transducers were placed on the end pallets, a center pallet, the sill, and a coupler for a total of five locations. Also, six load cells were inserted between the center gates. The impacts took place as follows:

IMPACT NO.	SPEED (mph)	GAP AT REAR OF LOAD (Inches)
1	4.23	3.25
2	6.34	4.00
3	8.60	6.75
4	8.44	9.00

Superficial damage to the top adaptors of the pallets located against the end wall in the form of minor dents occurred due to pallet misalignment. Additionally, several of the wooden pallets used to fill out the load experienced severe damage to the top adaptor, resulting in the large gaps noted above.

PART 6

PHOTOGRAPHS

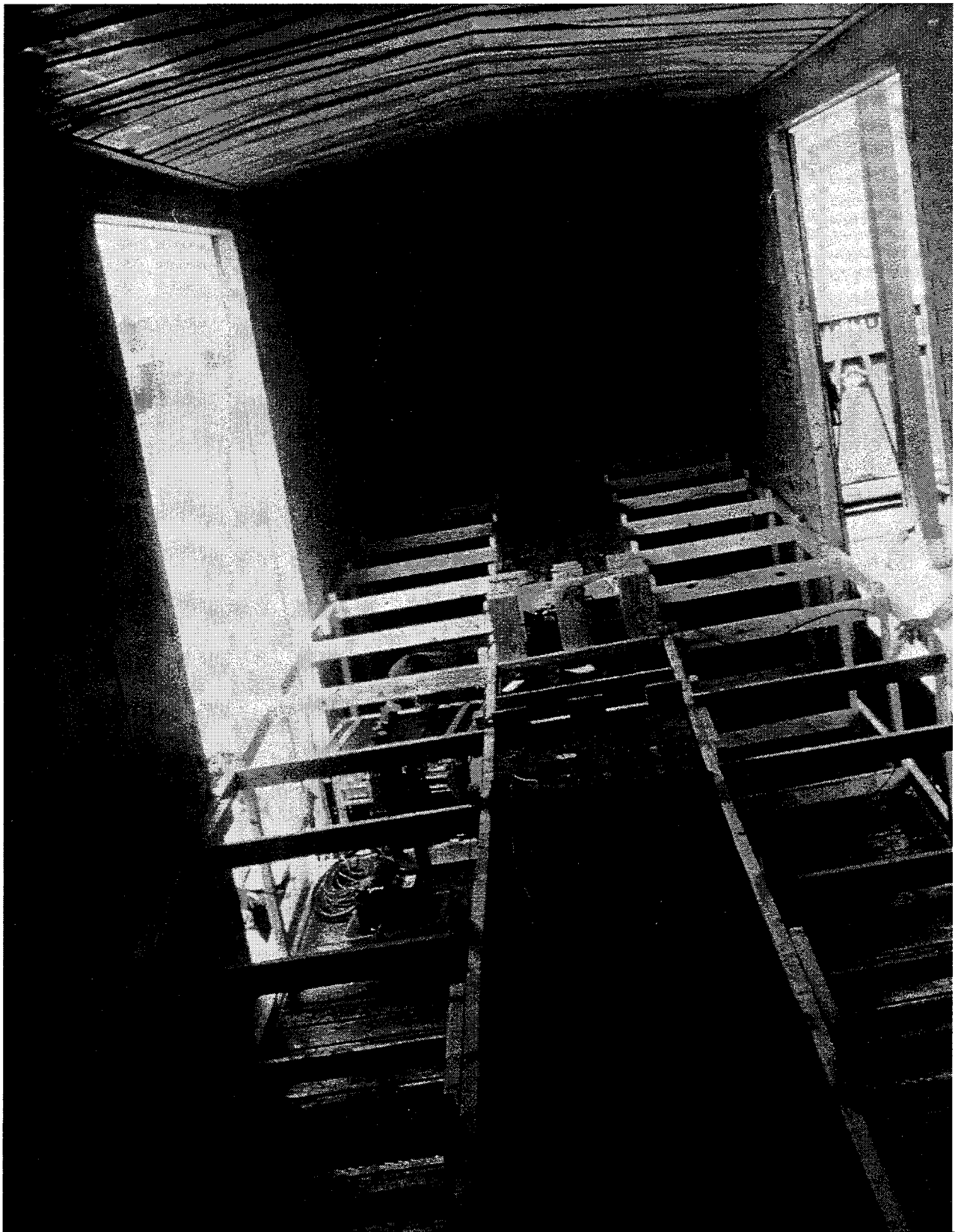

	U.S. ARMY DEFENSE AMMUNITION CENTER AND SCHOOL - SAVANNA, IL	
--	---	--

PHOTO NO. A0317-SCN94-257-5033: This photo shows the overall view of the test load. Note the three metal pallets are located at both ends of the railcar as well as six metal pallets located at the center of the test load.

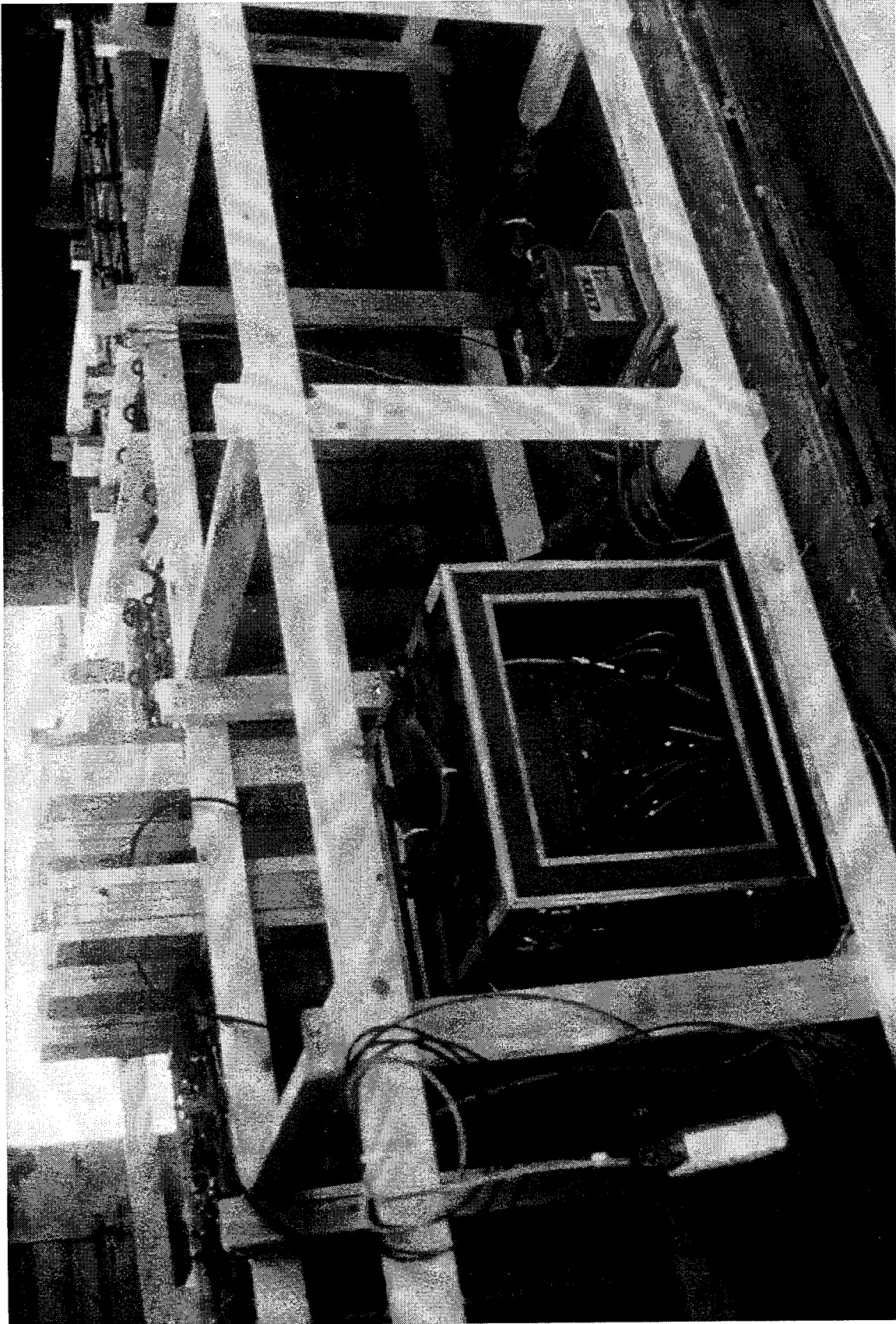

U.S. ARMY DEFENSE AMMUNITION CENTER AND SCHOOL - SAVANNA, IL

PHOTO NO. 0317-SCN94-257-5036: This photo shows a closeup view of the high-speed data acquisition system used during rail impact testing. Note the accelerometers are located at both ends of the railcar as well as at the center. The load cells were also placed between the center gates to determine the load forces.



U.S. ARMY DEFENSE AMMUNITION CENTER AND SCHOOL - SAVANNA, IL

PHOTO NO. 0317-SPN-90-329-5214: This photo shows a closeup view of the metal top pallet adapter.

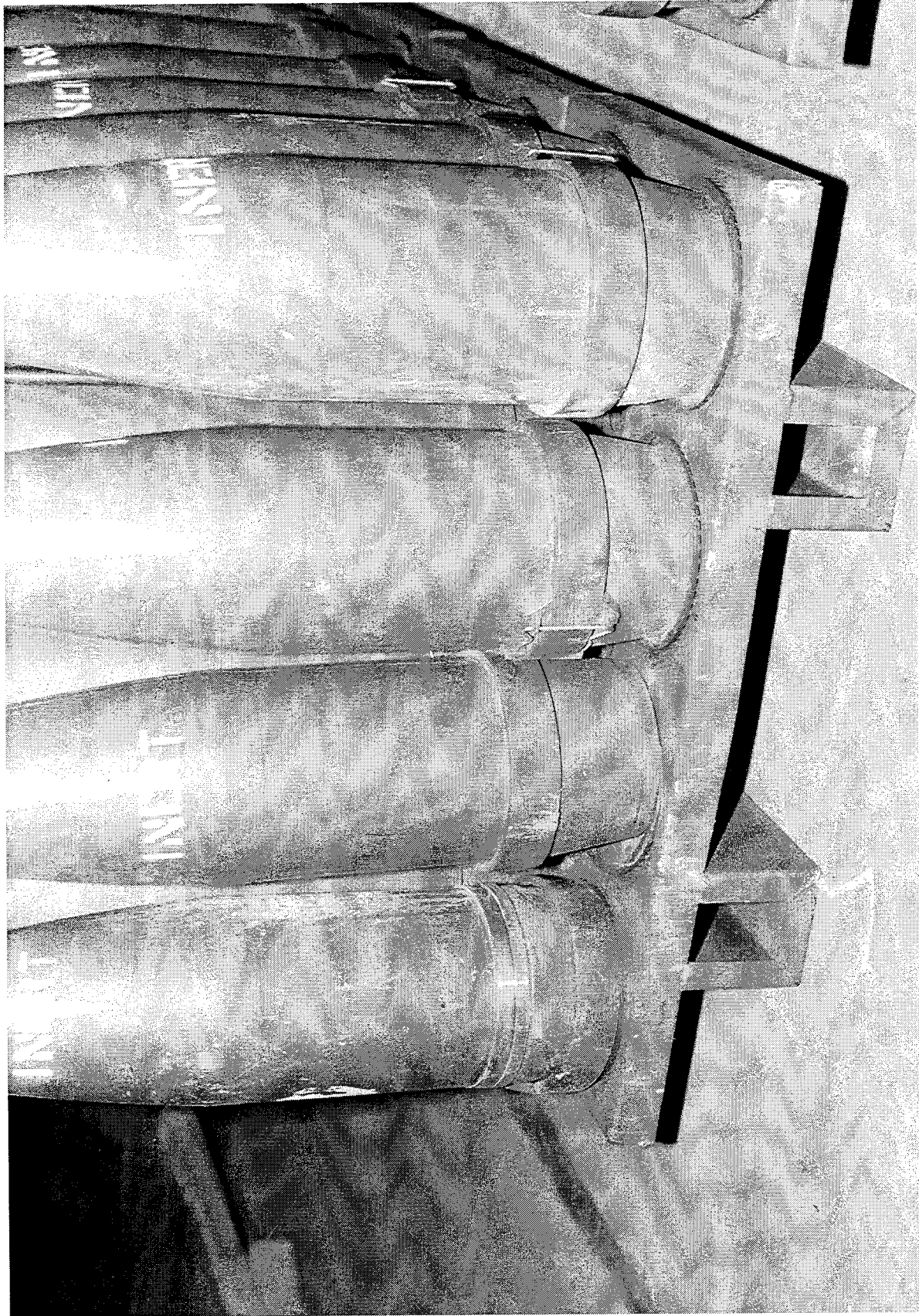

U.S. ARMY DEFENSE AMMUNITION CENTER AND SCHOOL - SAVANNA, IL

PHOTO NO. 0317-SPN-90-329-5455: This photo shows a closeup view of the metal bottom pallet adapter.



U.S. ARMY DEFENSE AMMUNITION CENTER AND SCHOOL - SAVANNA, IL

PHOTO NO. 0317-SCN94-257-5039 This photo shows a closeup view of the inert-filled 155mm wooden pallets used to fill out the test load. Note that substantial damage occurred to the top pallet adapter following rail impact testing.

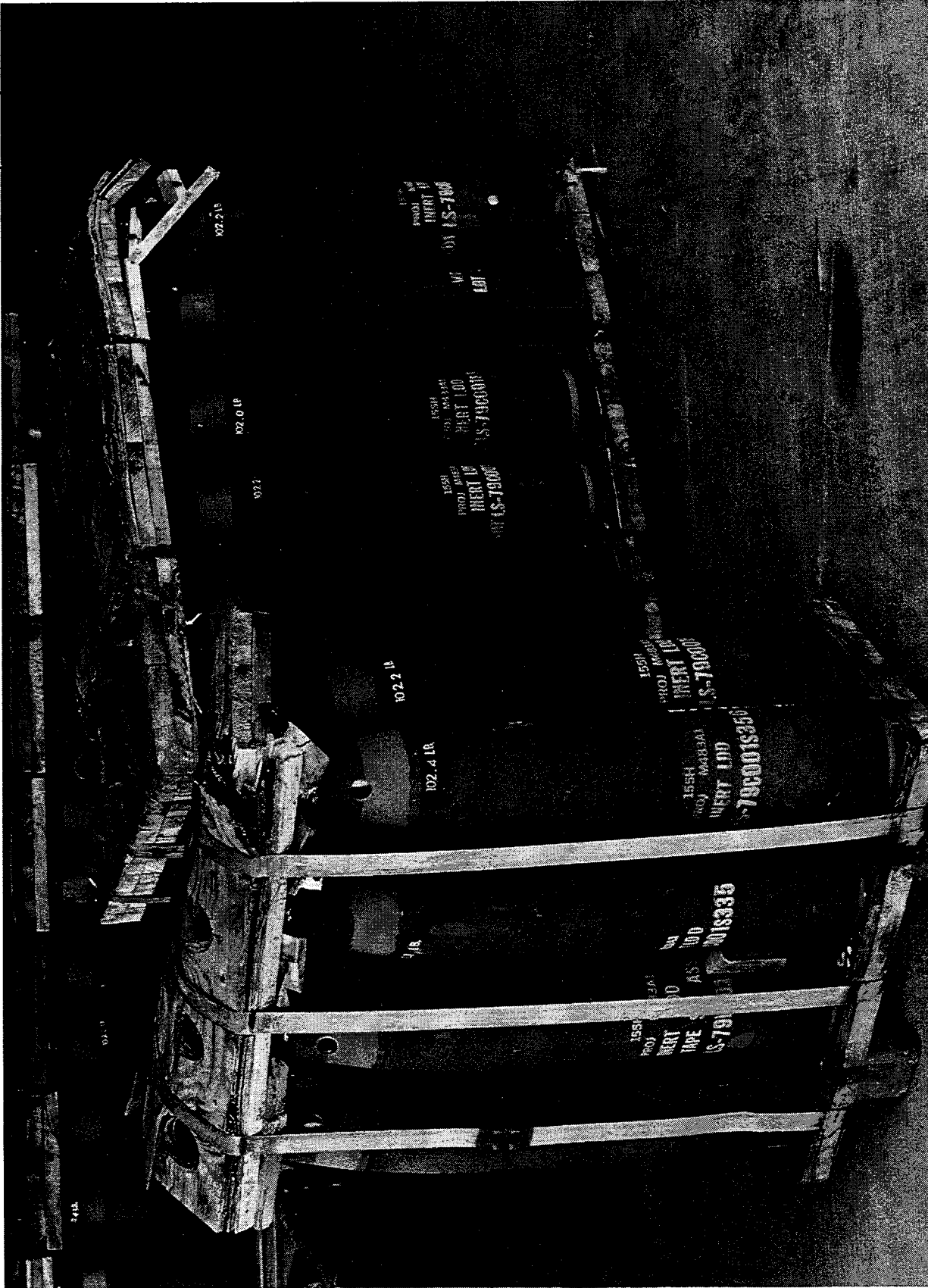

U.S. ARMY DEFENSE AMMUNITION CENTER AND SCHOOL - SAVANNA, IL

PHOTO NO. 0317-SCN94-222-4180: This photo shows a closeup view of the inert wooden pallets used during testing. Note the extreme damage which occurred to the wooden top pallet adapters.

PART 7

GRAPHS

R.I. of FAPP, Impact 2: 6 MPH

Aug 17 09:49:57 1994

7

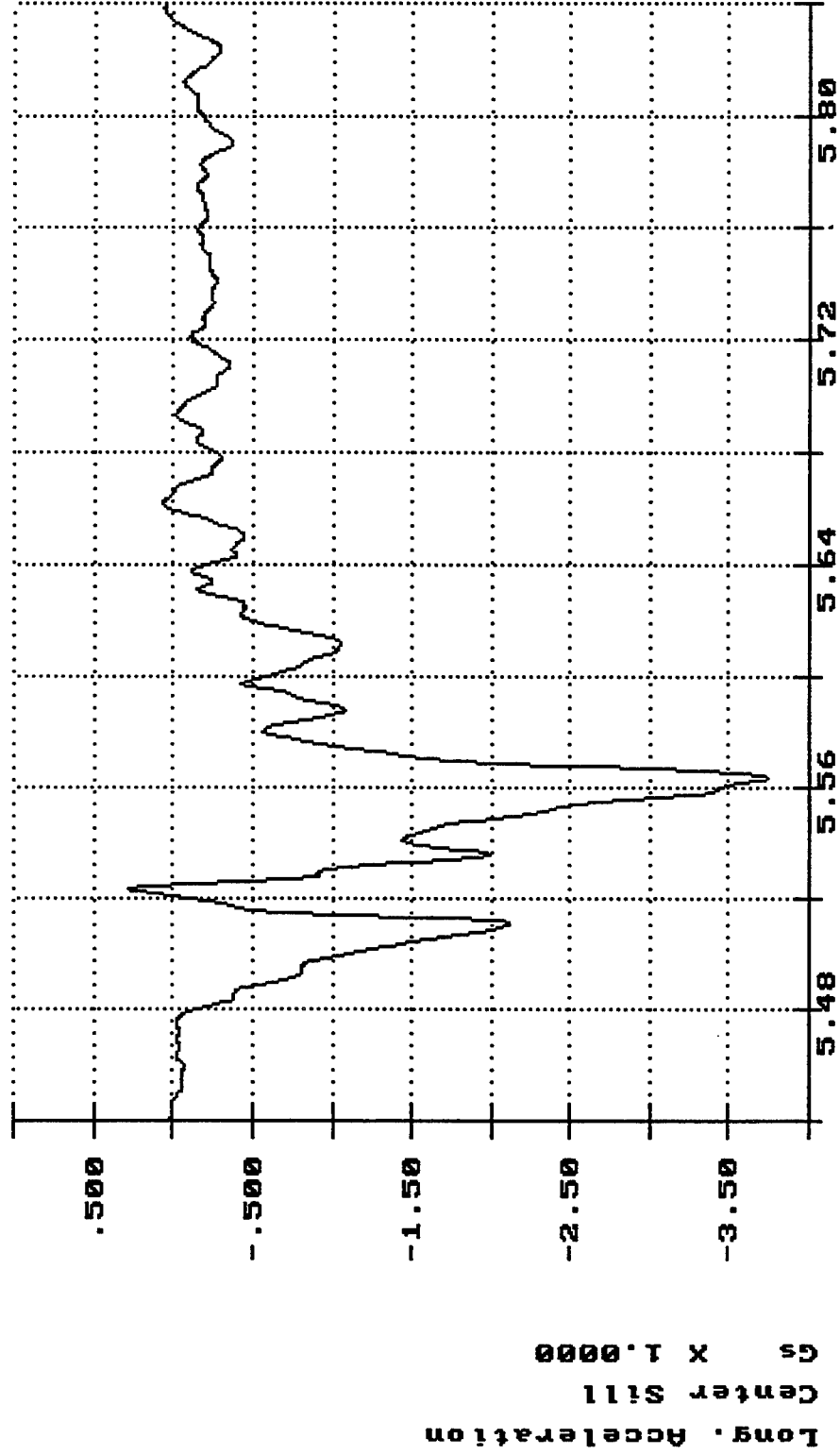

Time of Sample
Seconds X 1.0000

R.I. of FAPP, Impact 2: 6 MPH Aug 17 09:49:57 1994

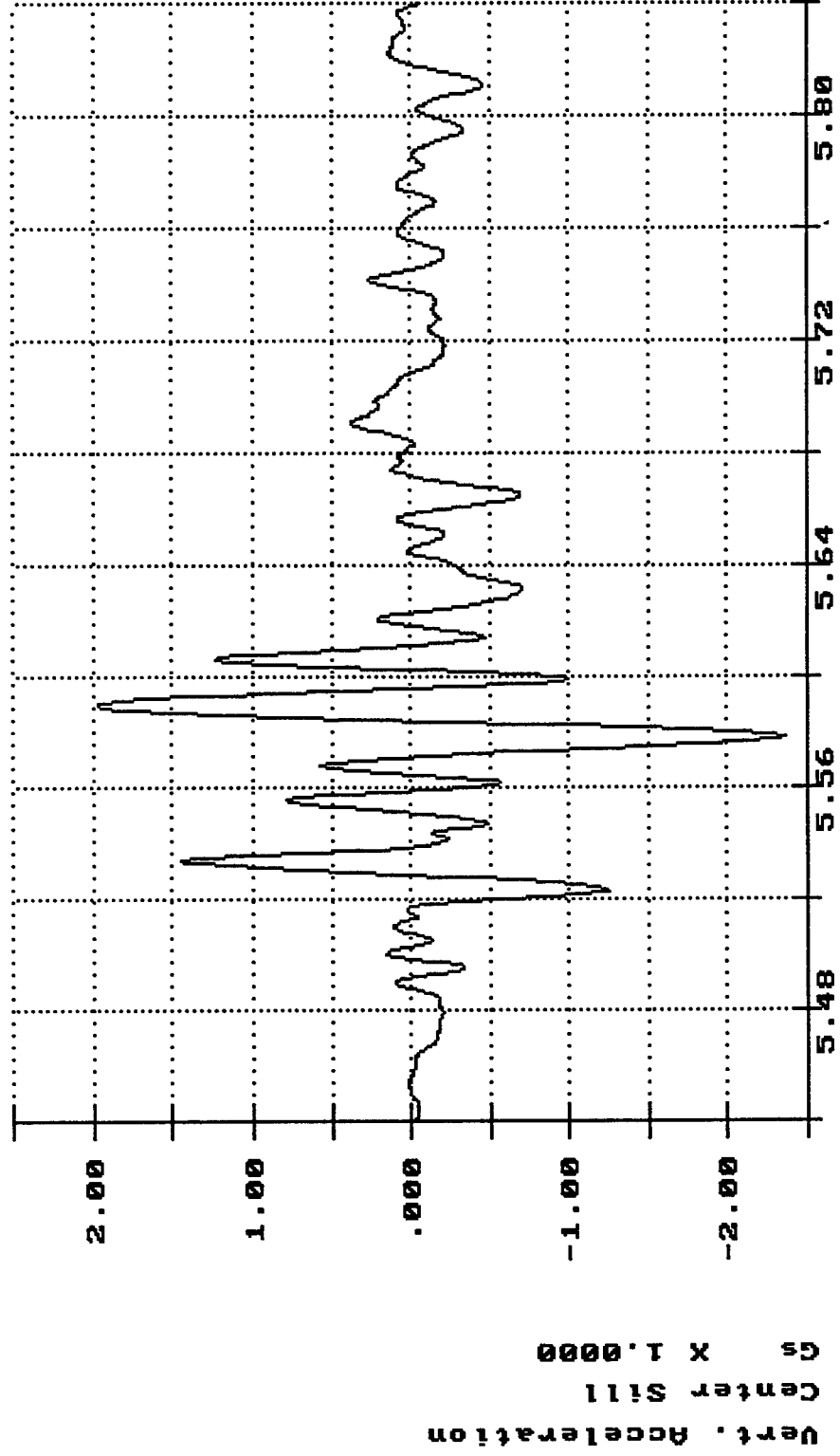

Time of Sample
Seconds X 1.0000

R.I. of FAPP, Impact 2: 6 MPH Aug 17 09:49:57 1994

7

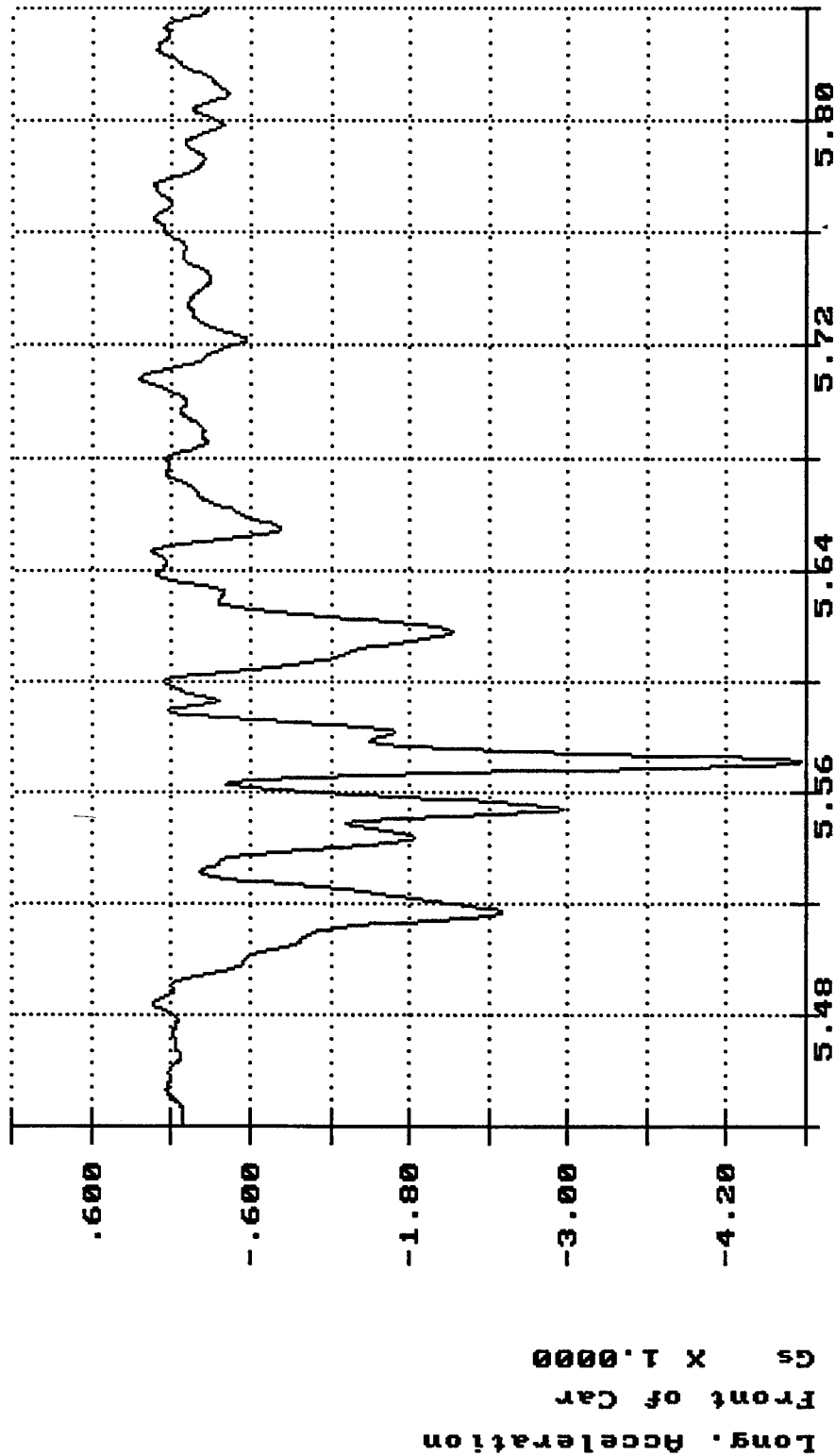

Time of Sample

Seconds X 1.0000

R.I. of FAPP, Impact 2: 6 MPH Aug 17 09:49:57 1994

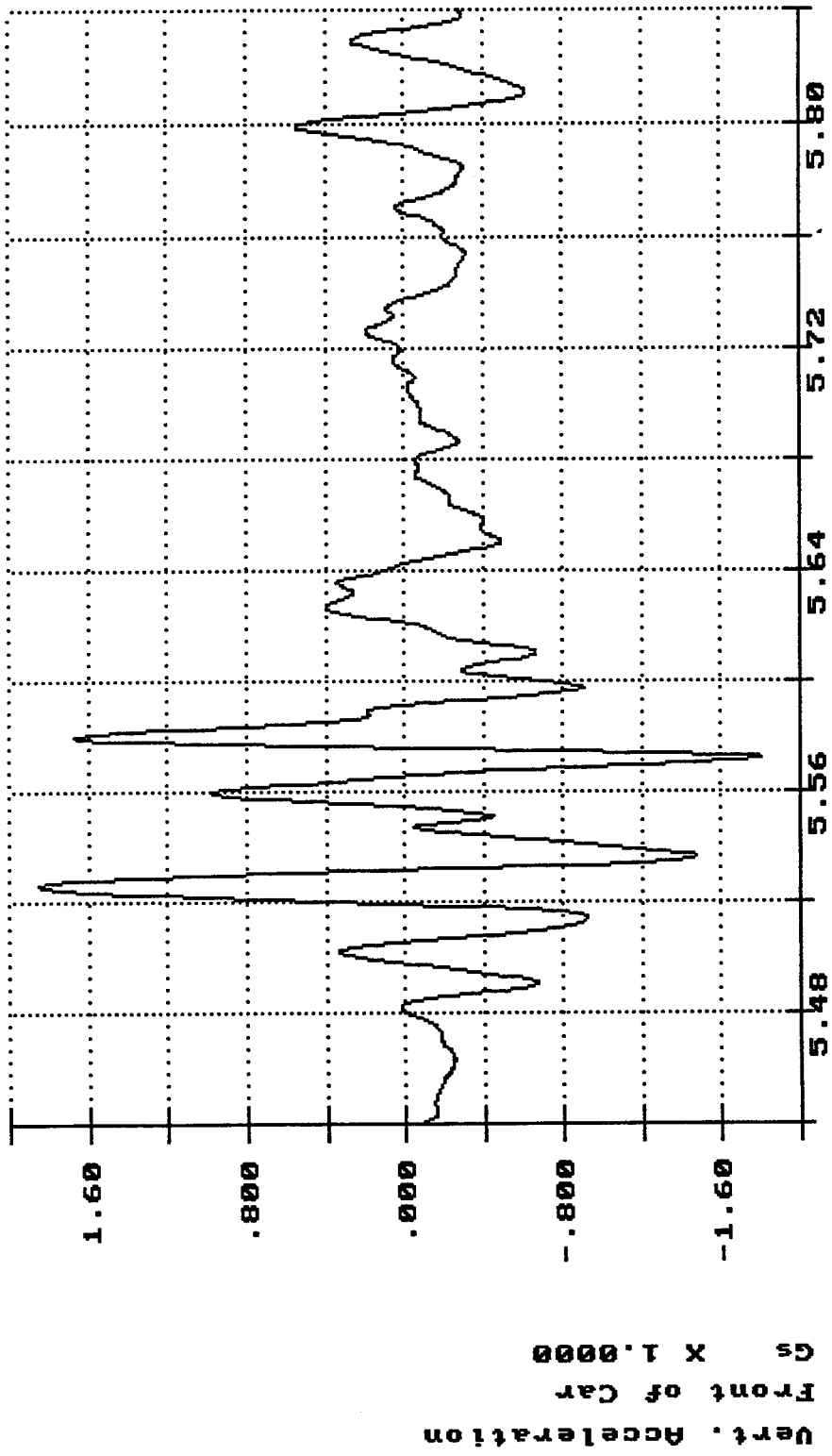

Time of Sample
Seconds X 1.0000

R.I. of FAPP, Impact 2: 6 MPH

Aug 17 09:49:57 1994

7

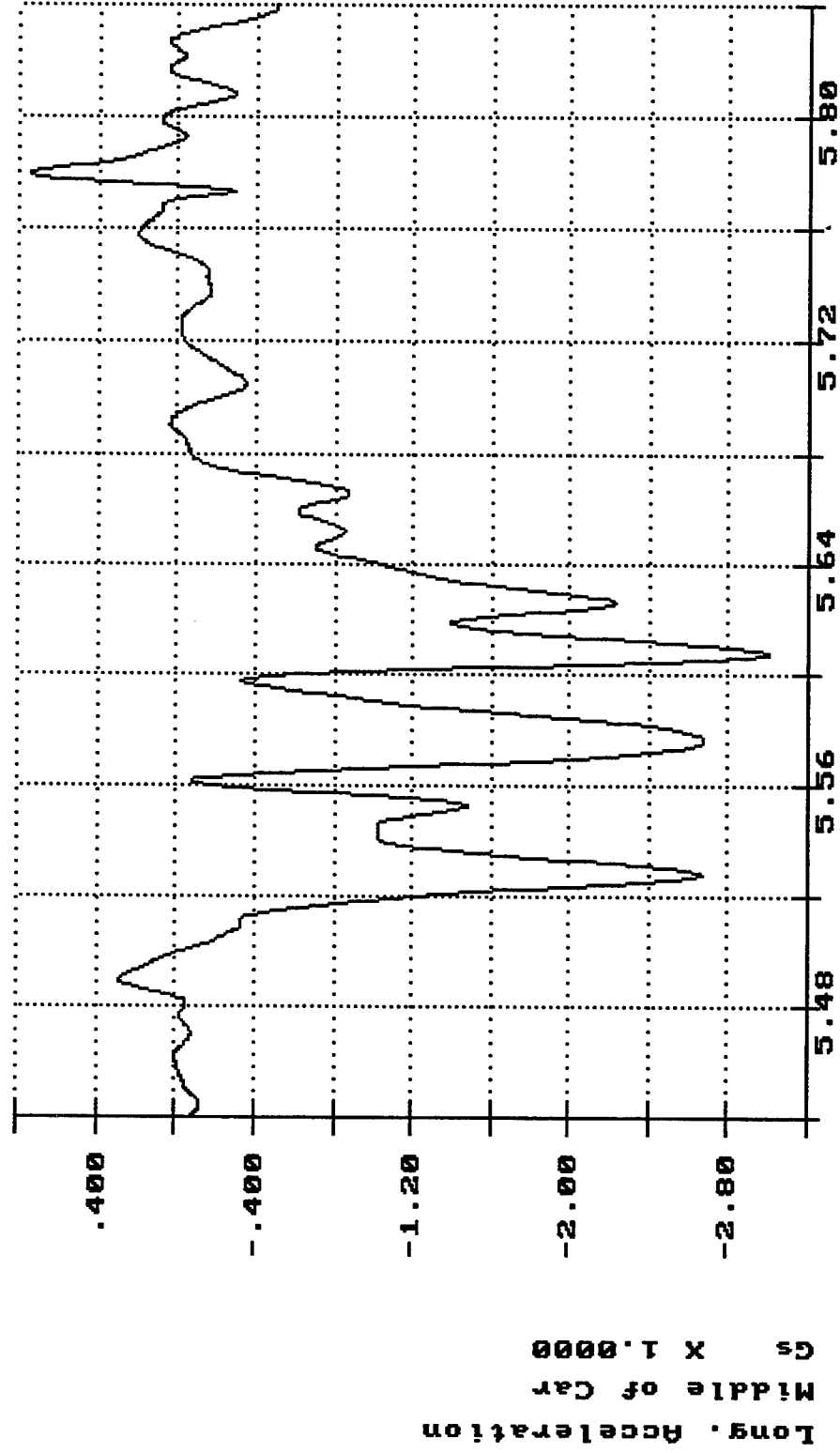

Time of Sample
Seconds X 1.0000

R.I. of FAPP, Impact 2: 6 MPH

Aug 17 09:49:57 1994

7

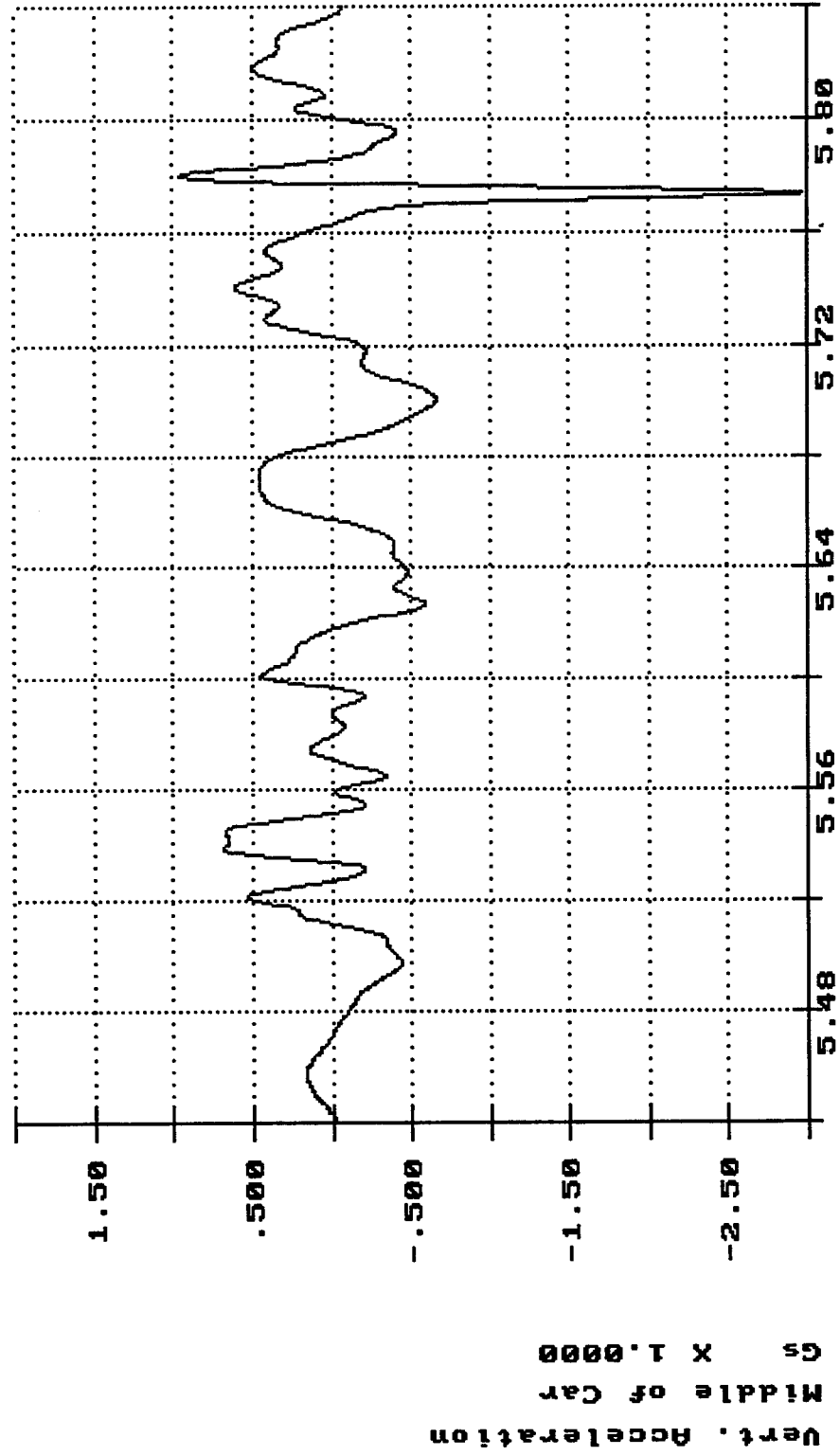

R.I. of FAPP, Impact 2: 6 MPH

Aug 17 09:49:57 1994

7

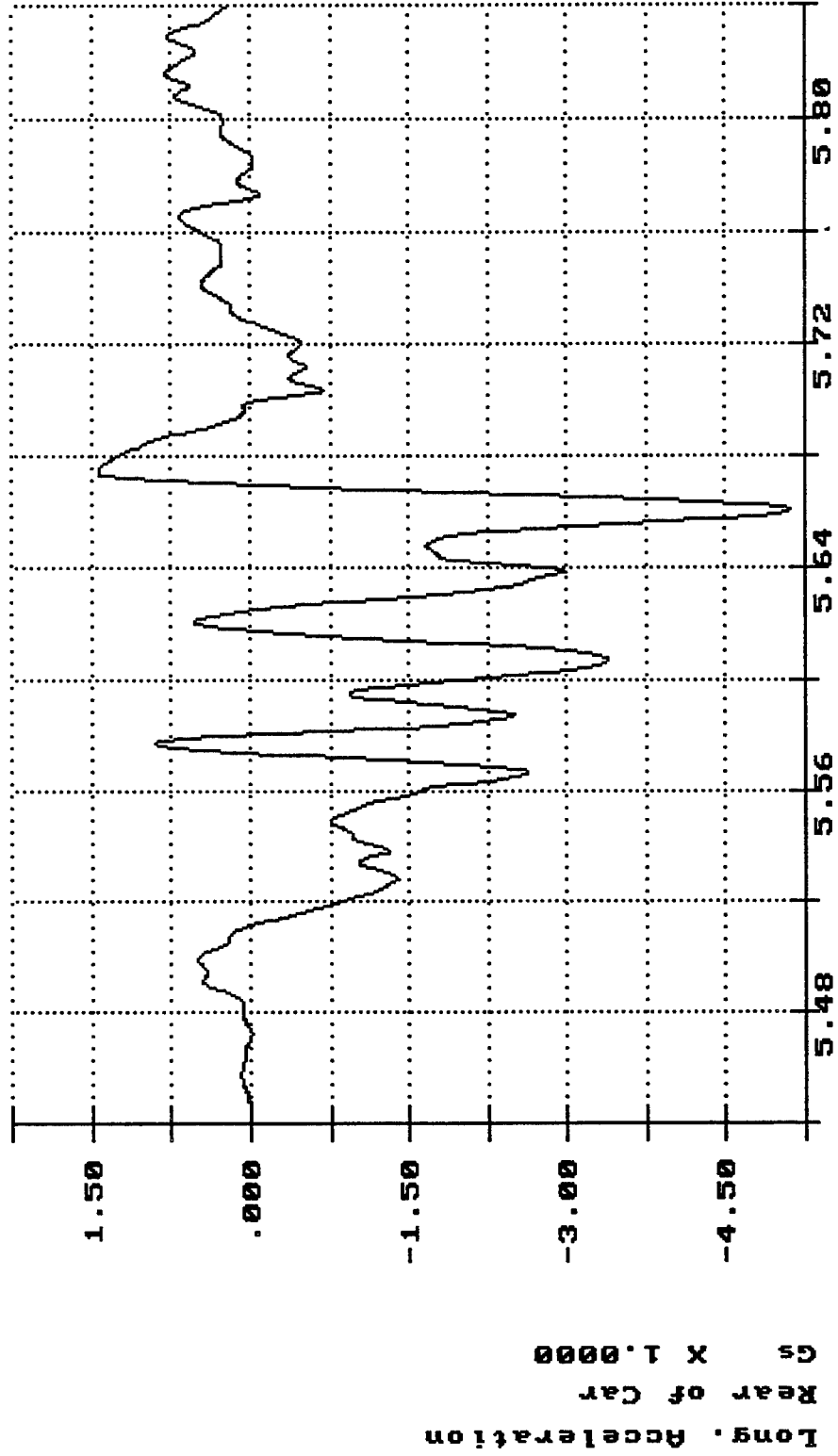

R.I. of FAPP, Impact 2: 6 MPH Aug 17 09:49:57 1994

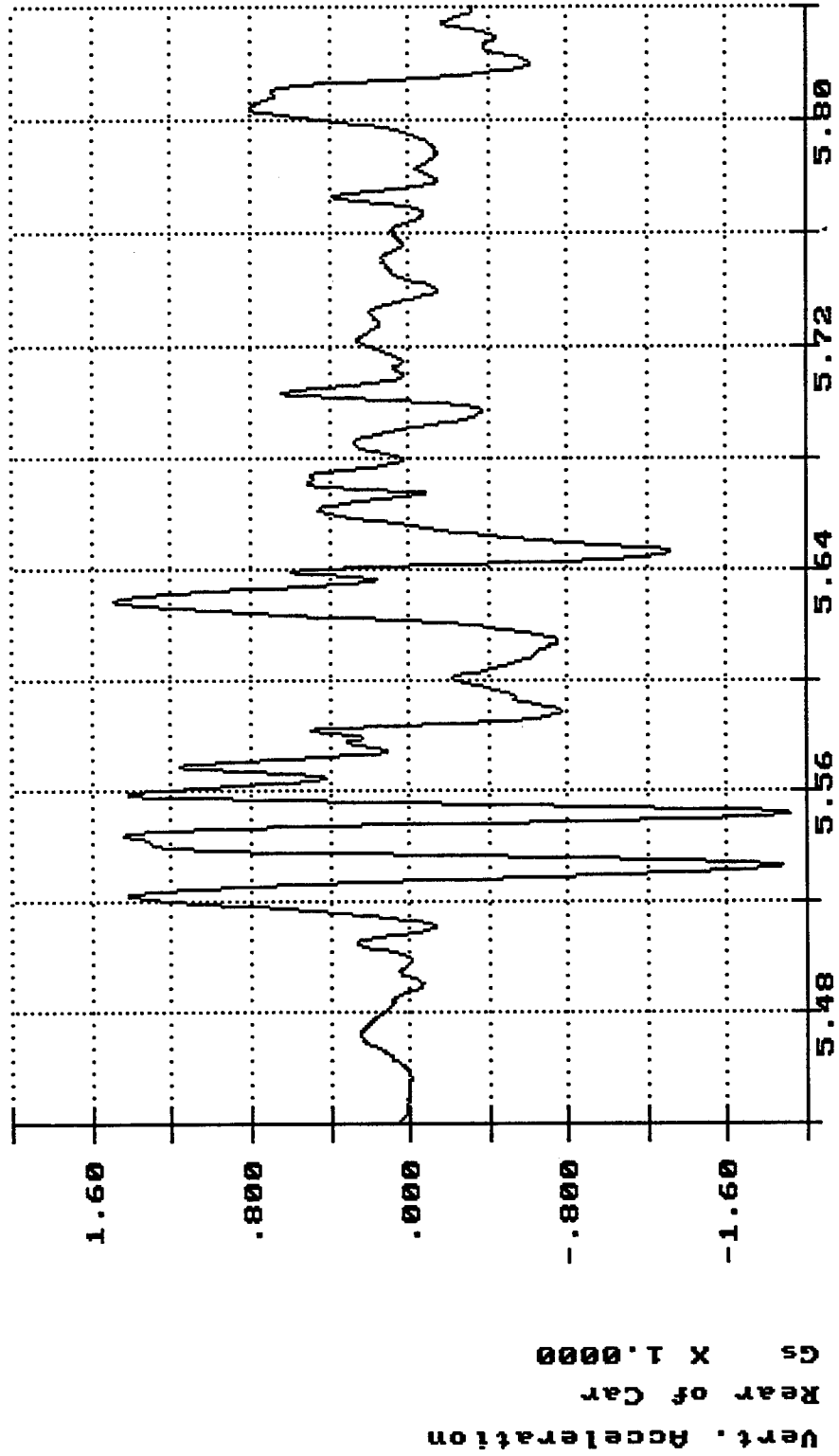

Time of Sample
Seconds X 1.0000

R.I. of FAPP, Impact 2: 6 MPH Aug 17 09:49:57 1994

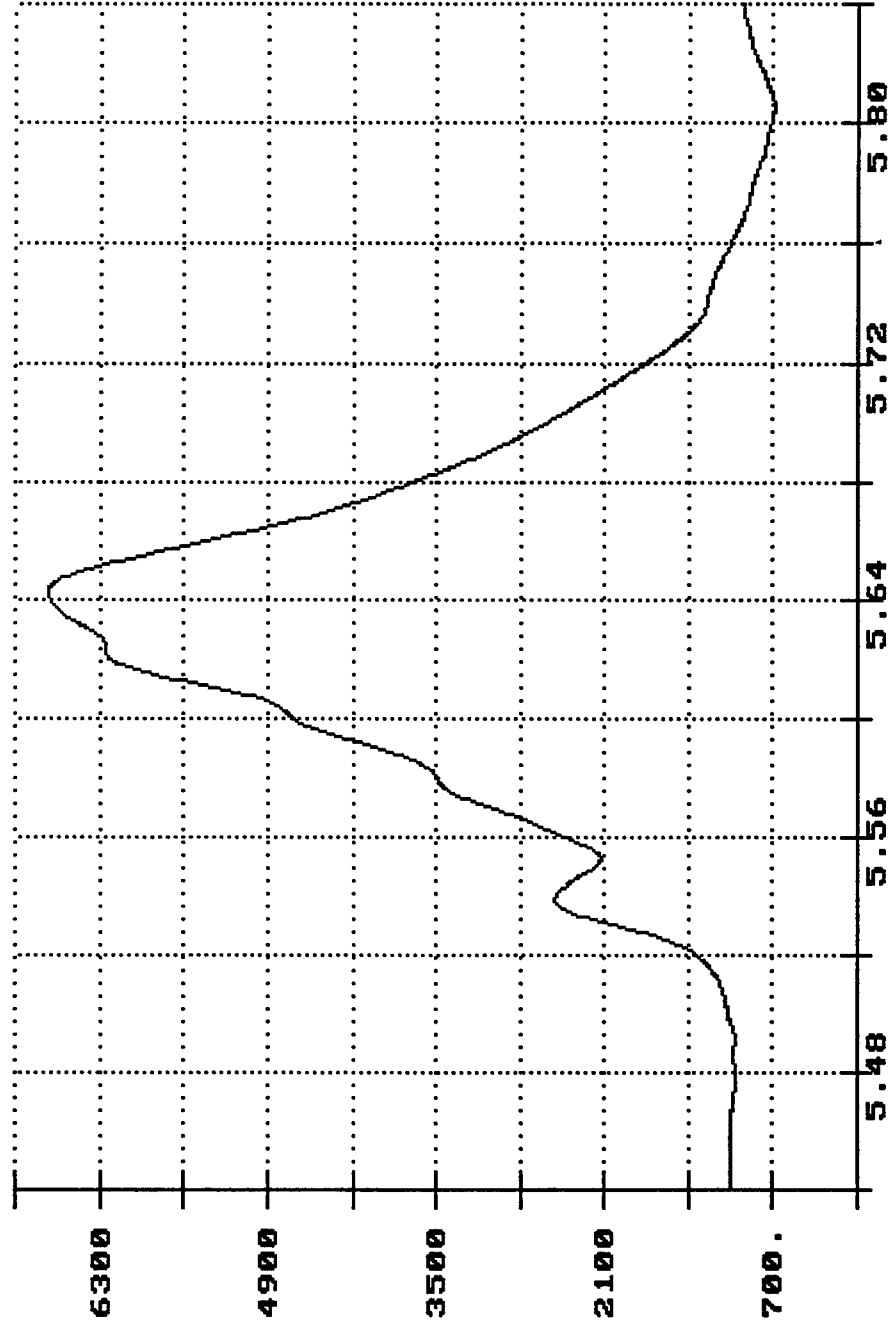

10K Load Cell
Top Left
LBS X 1.0000

Time of Sample
Seconds X 1.0000

R.I. of FAPP, Impact 2: 6 MPH Aug 17 09:49:57 1994

7

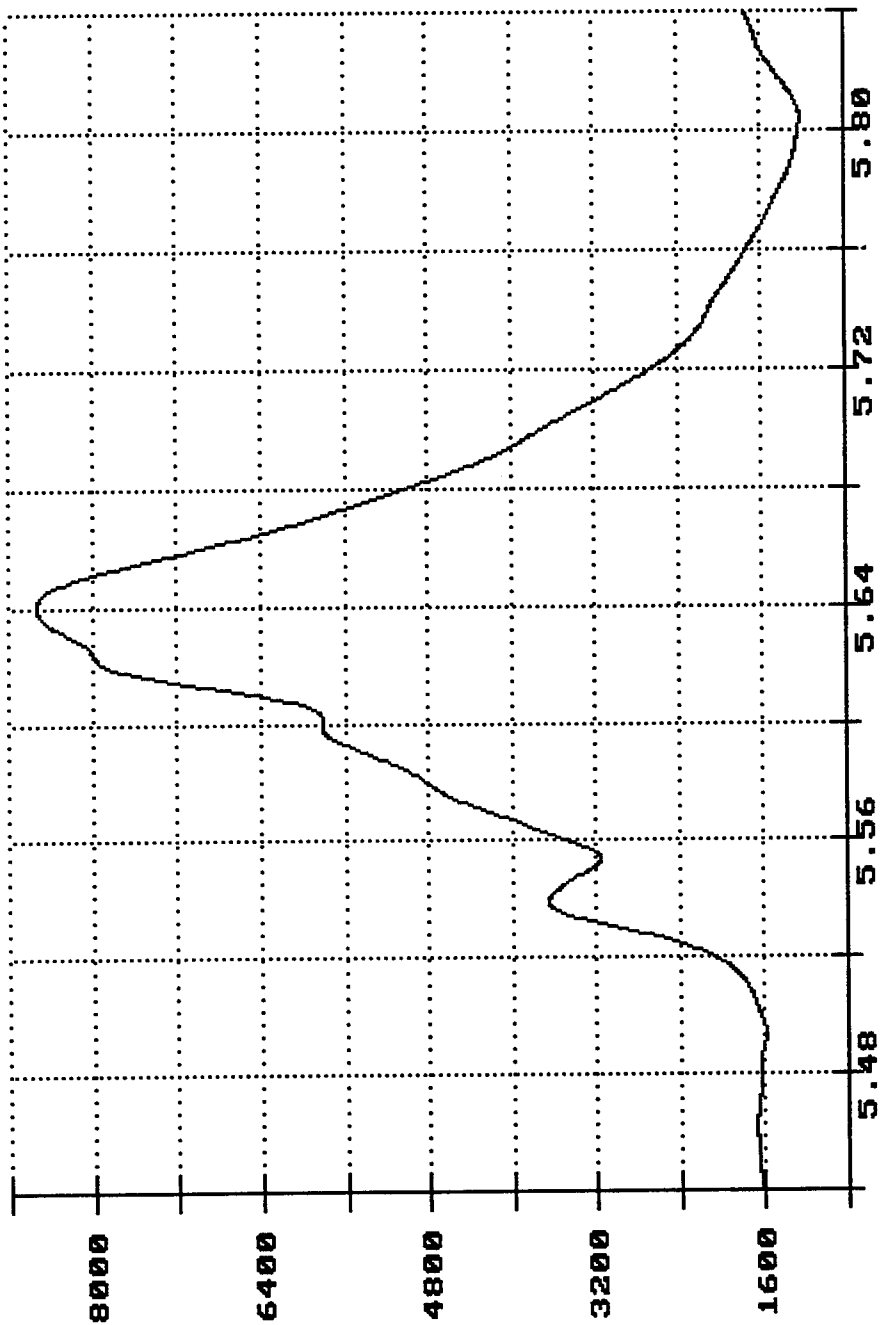

10K Load Cell
Top Center
LBS X 1.0000

Time of Sample
Seconds X 1.0000

R.I. of FAPP, Impact 2: 6 MPH

Aug 17 09:49:57 1994

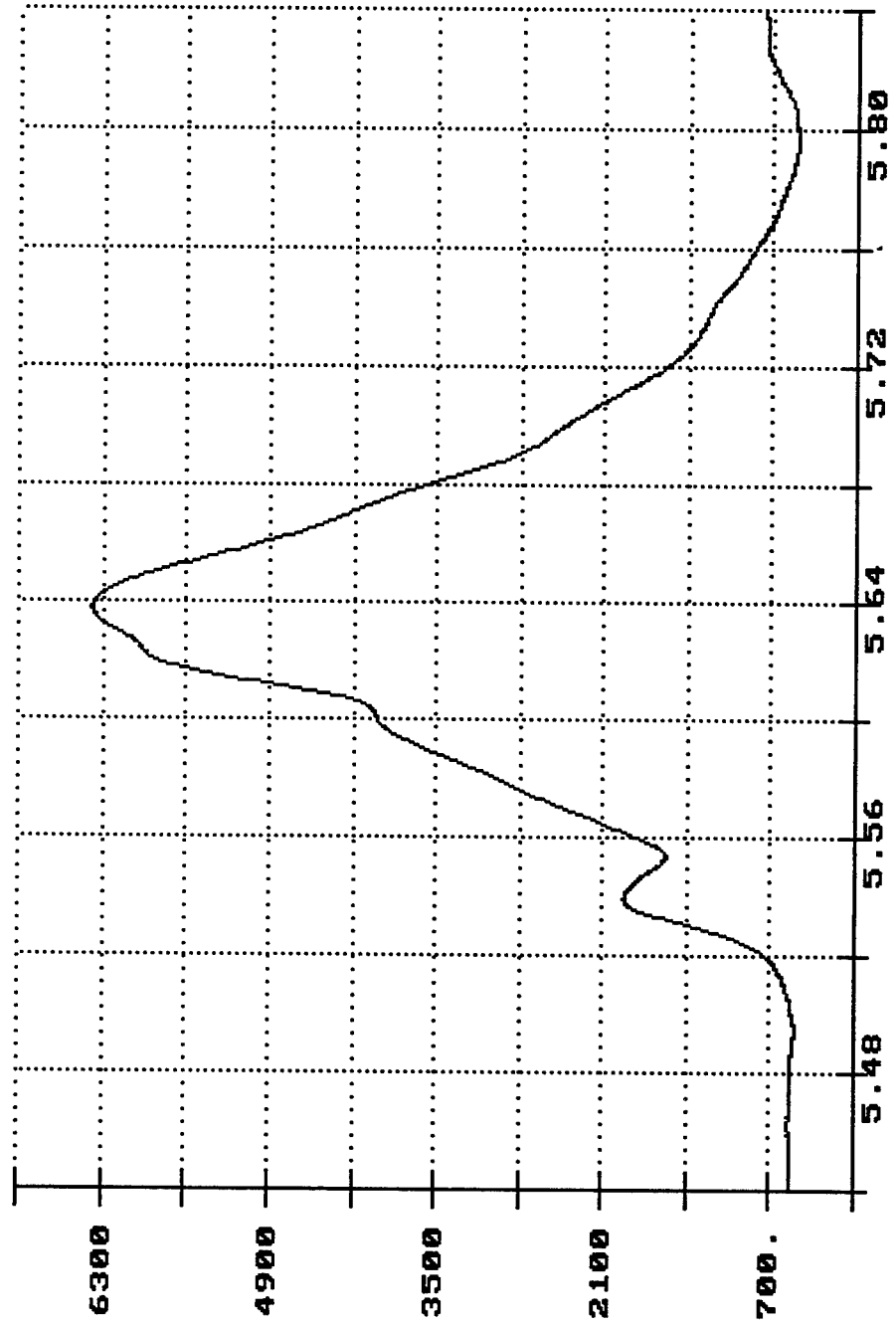

Time of Sample

Seconds X 1.0000

R.I. of FAPP, Impact 2: 6 MPH Aug 17 09:49:57 1994

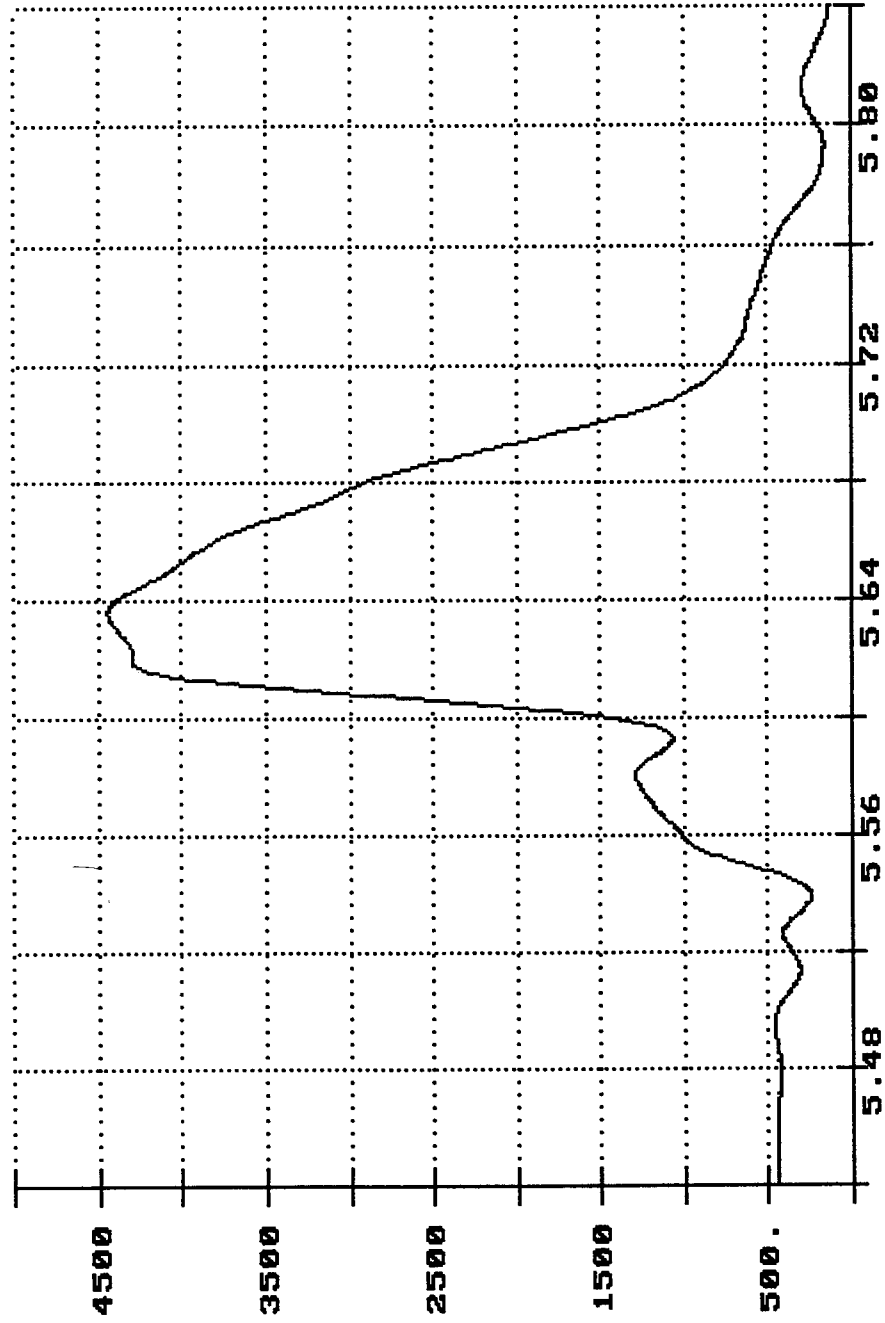

10K Load Cell
Bottom Left
LBS X 1.0000

Time of Sample
Seconds X 1.0000

R.I. of FAPP, Impact 2: 6 MPH

Aug 17 09:49:57 1994

7

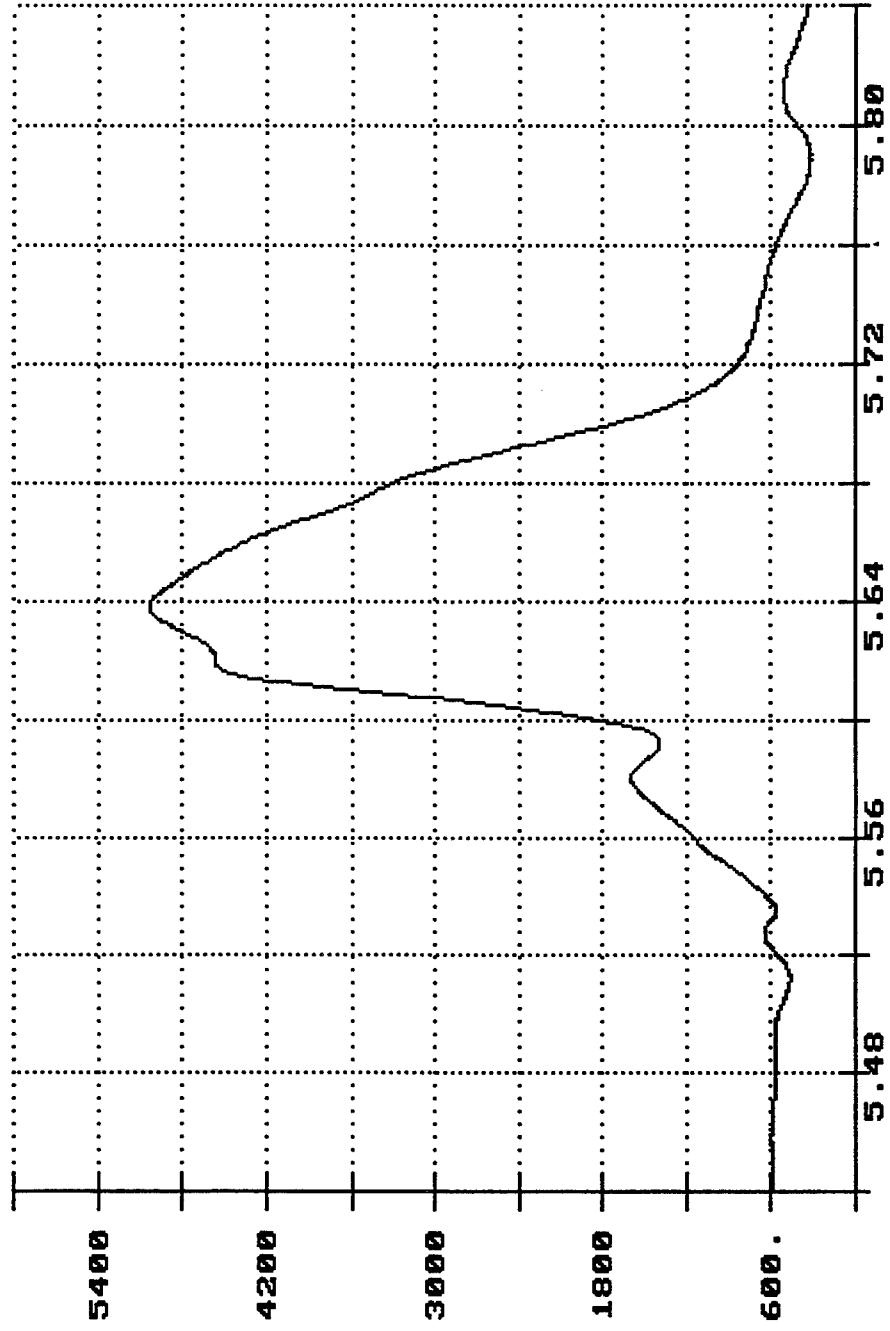

10X Load Cell
Bottom Center
LBS X 1.0000

Time of Sample
Seconds X 1.0000

R.I. of FAPP, Impact 2: 6 MPH

Aug 17 09:49:57 1994

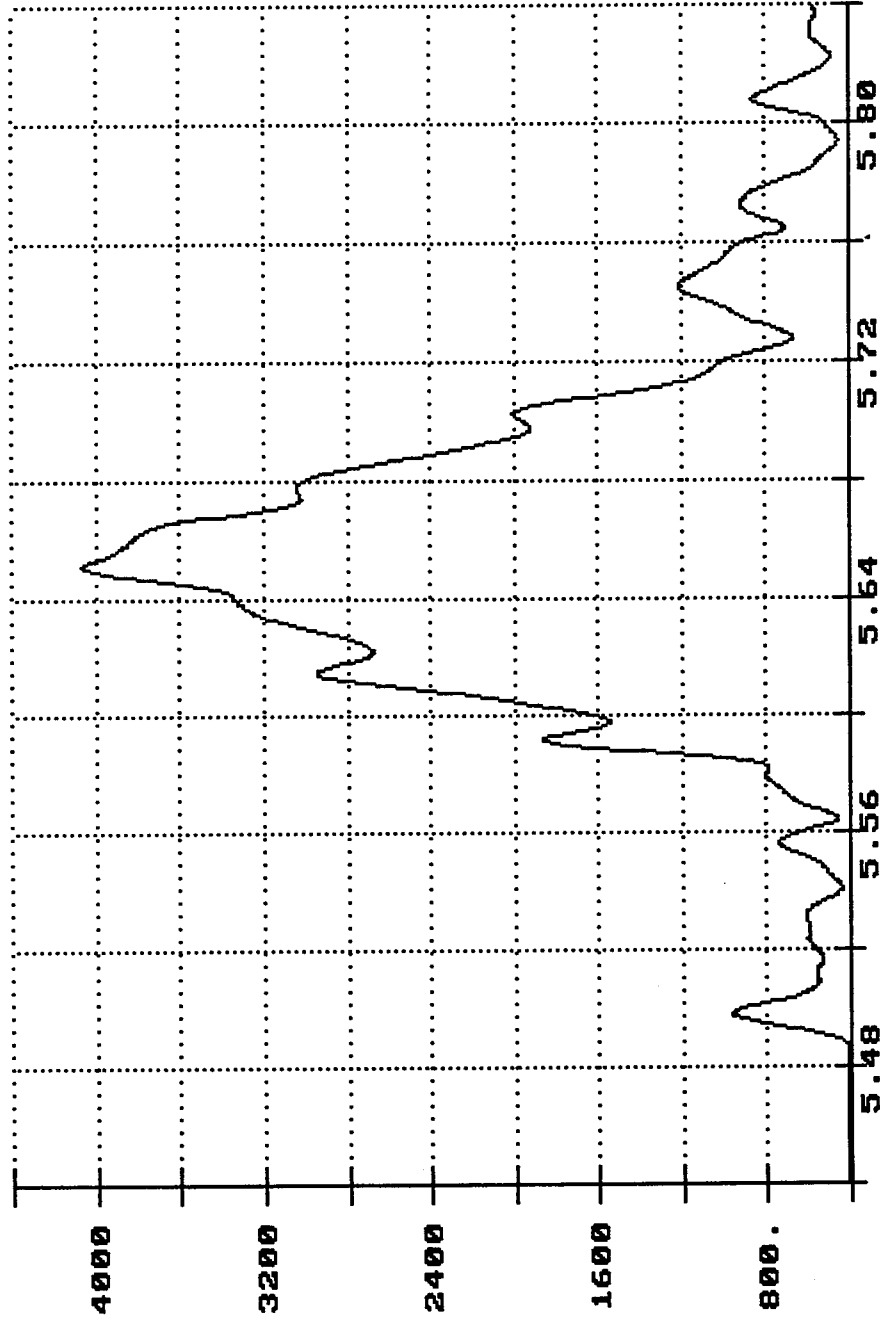

10K Load Cell
Bottom Right
LBS X 1.0000

Time of Sample

Seconds X 1.0000

R.I. of FAPP, Impact 3: 8.1+ MPH Aug 17 09:57:30 1994

7

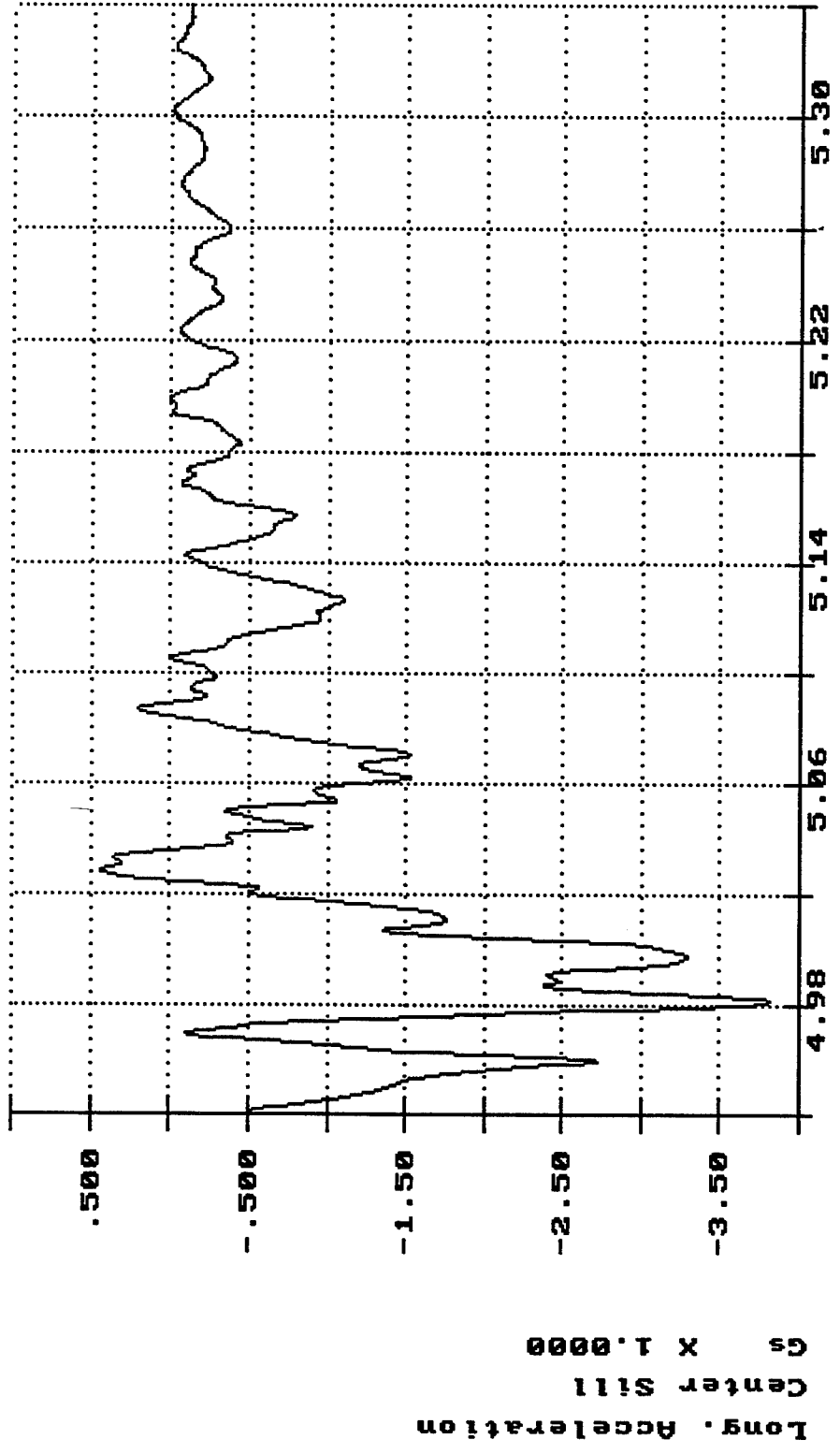

Time of Sample
Seconds X 1.0000

R.I. of FAPP, Impact 3: 8.1+ MPH Aug 17 09:57:30 1994

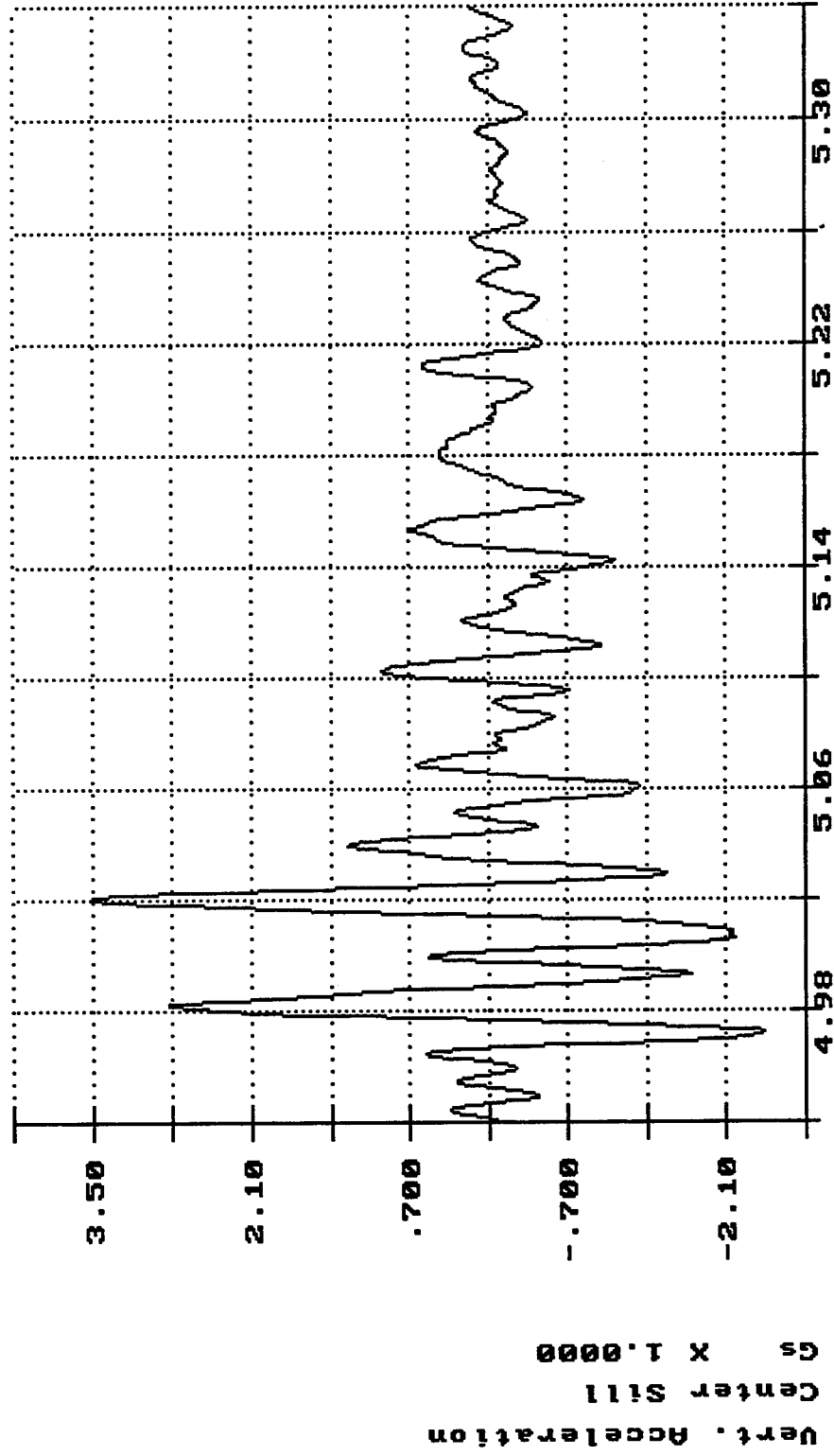

Time of Sample
Seconds X 1.0000

R.I. of FAPP, Impact 3: 8.1+ MPH Aug 17 09:57:30 1994

7

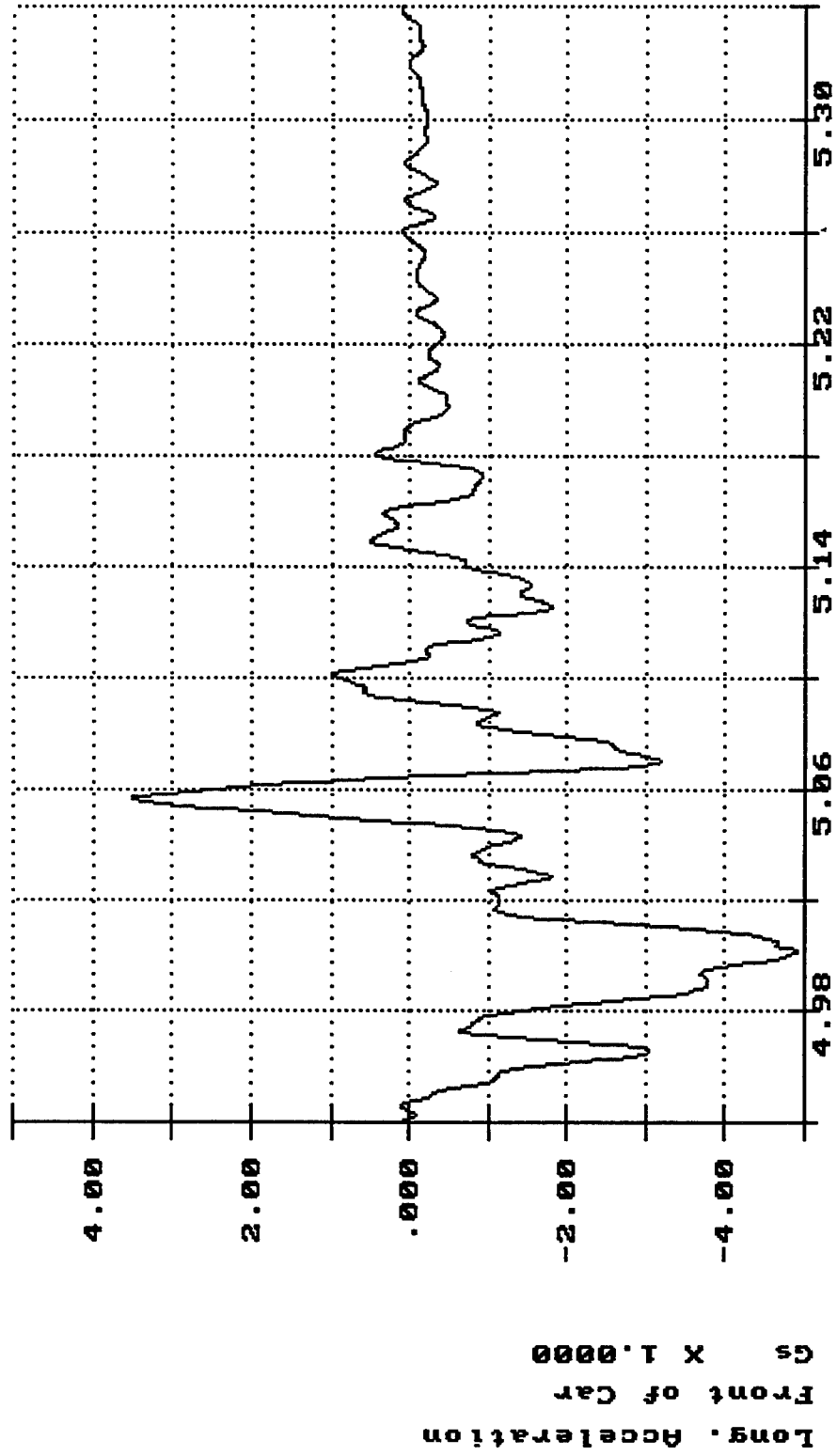

Time of Sample
Seconds X 1.0000

R.I. of FAPP, Impact 3: 8.1+ MPH Aug 17 09:57:30 1994

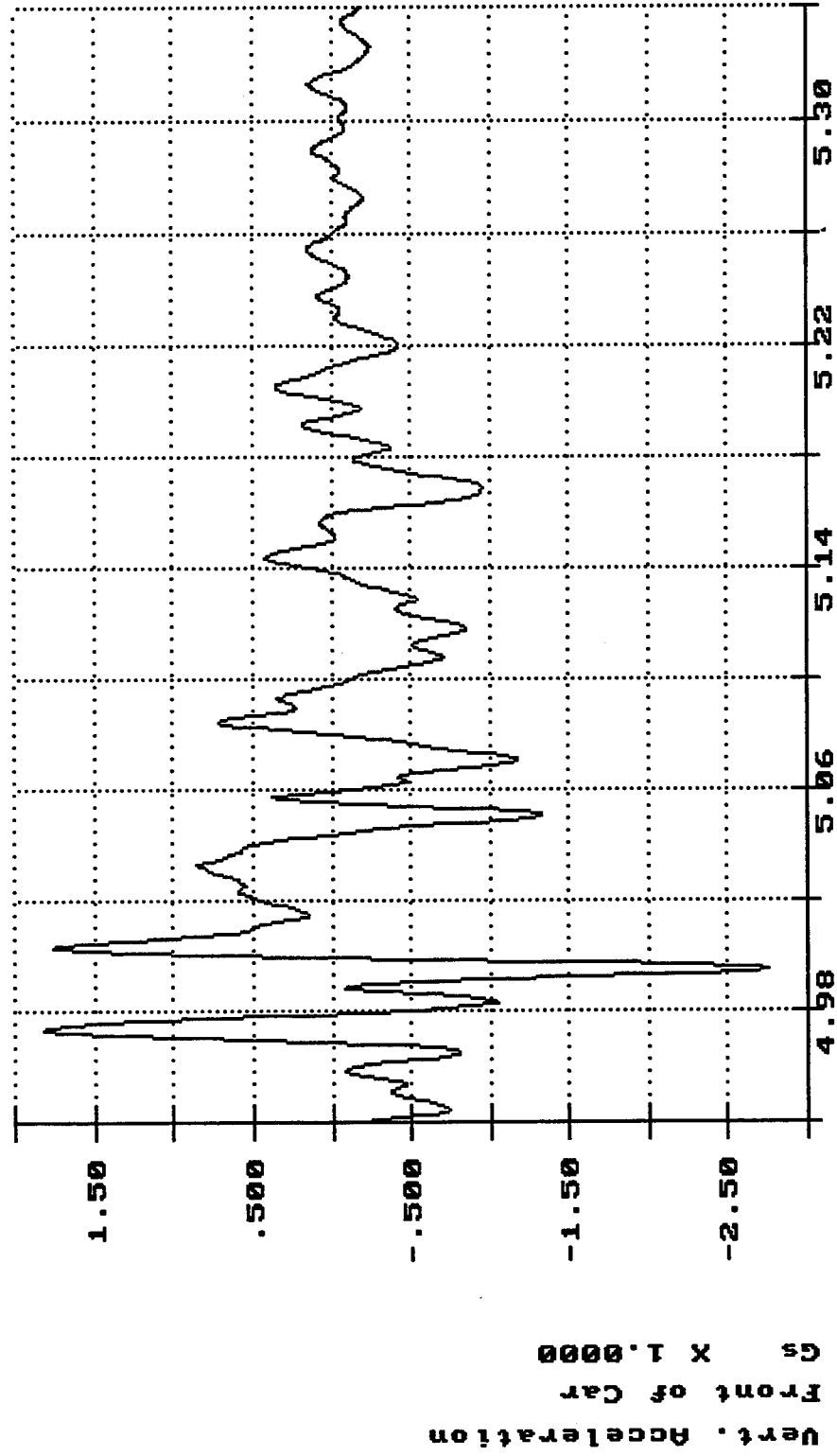

R.I. of FAPP, Impact 3: 8.1+ MPH Aug 17 09:57:30 1994

7

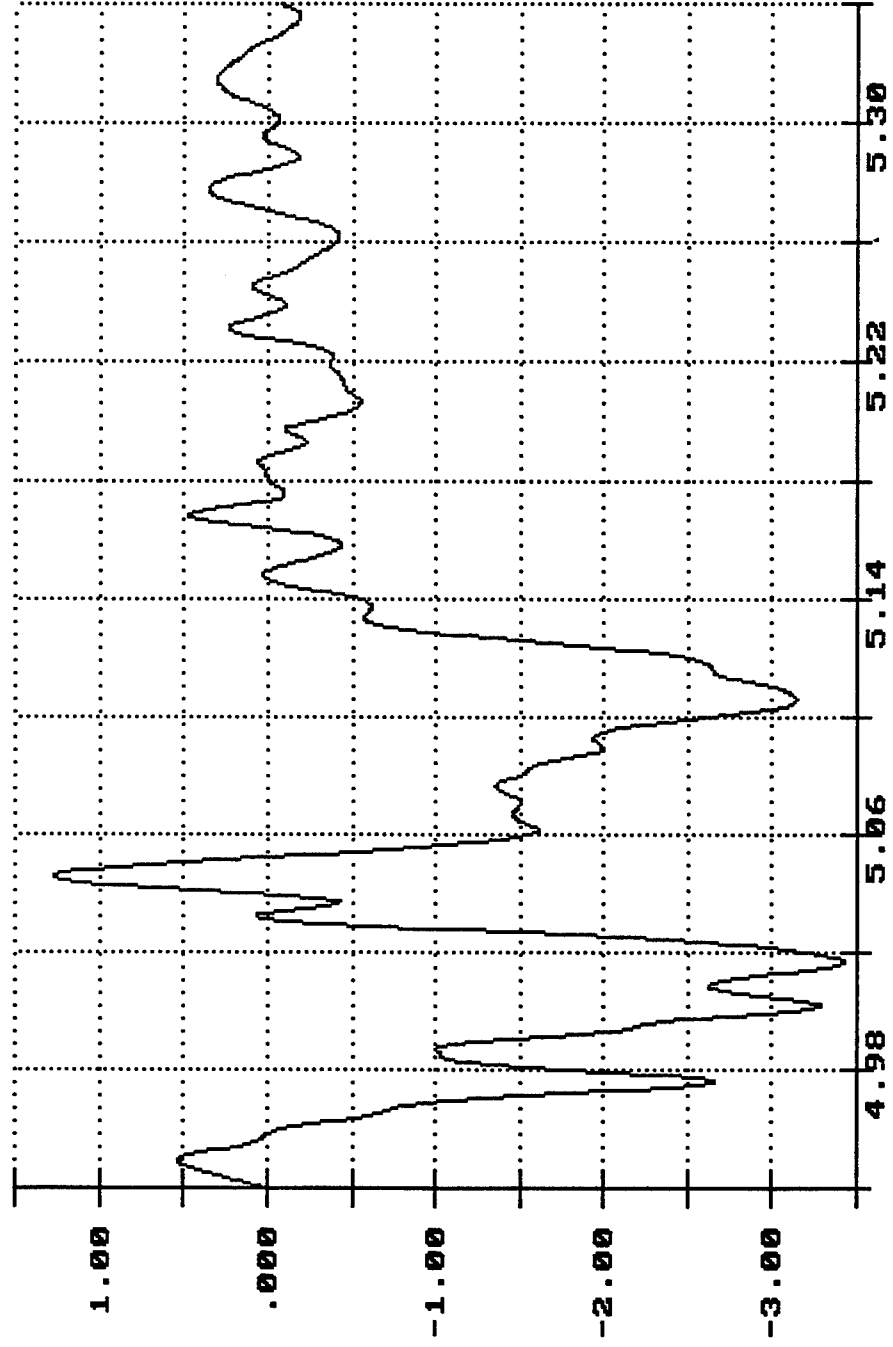

Time of Sample

Seconds X 1.0000

R.I. of FAPP, Impact 3: 8.1+ MPH Aug 17 09:57:30 1994

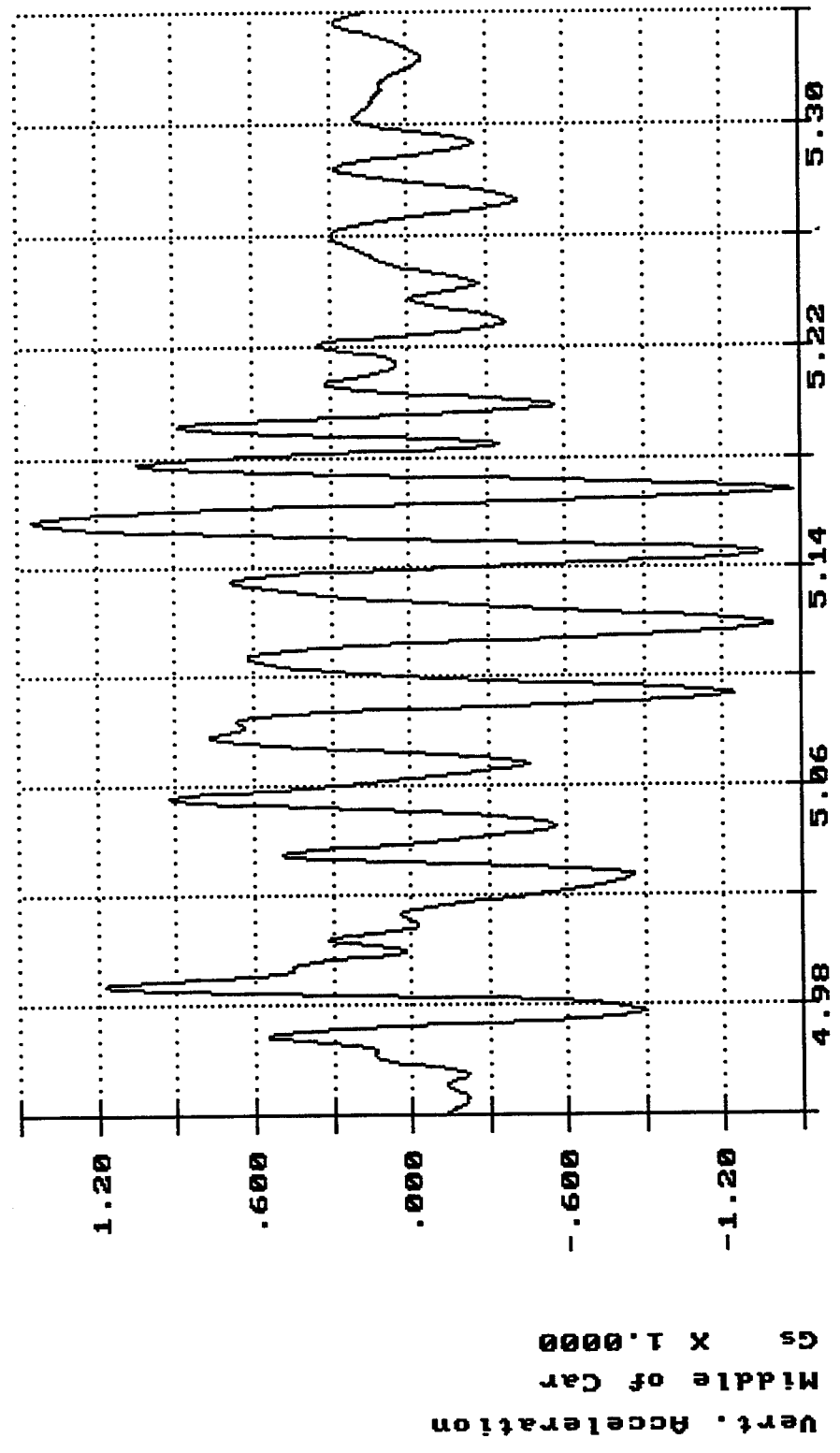

Time of Sample
Seconds X 1.0000

R.I. of FAPP, Impact 3: 8.1+ MPH Aug 17 09:57:30 1994

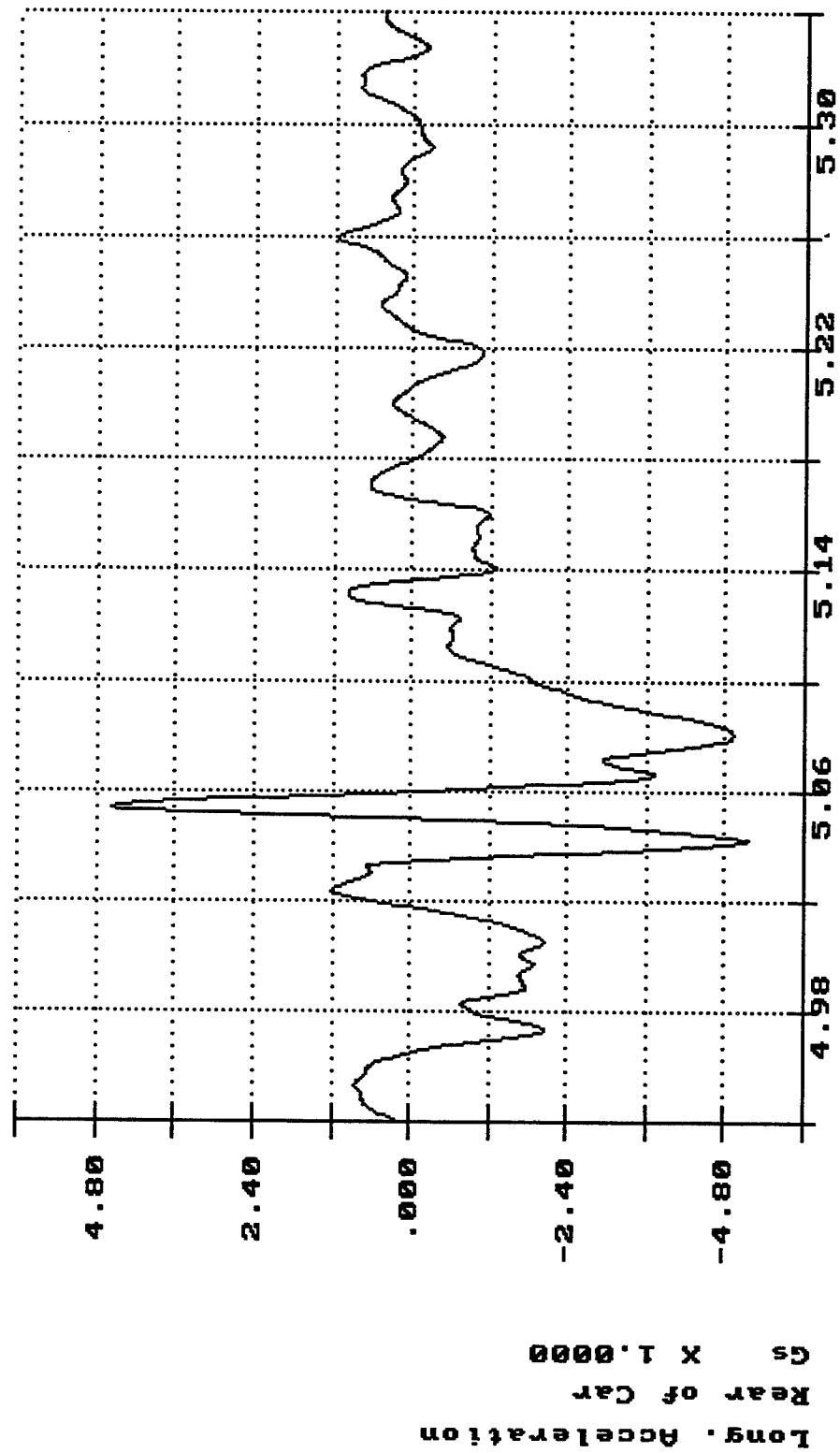

Time of Sample
Seconds X 1.0000

R.I. of FAPP, Impact 3: 8.1+ MPH Aug 17 09:57:30 1994

7

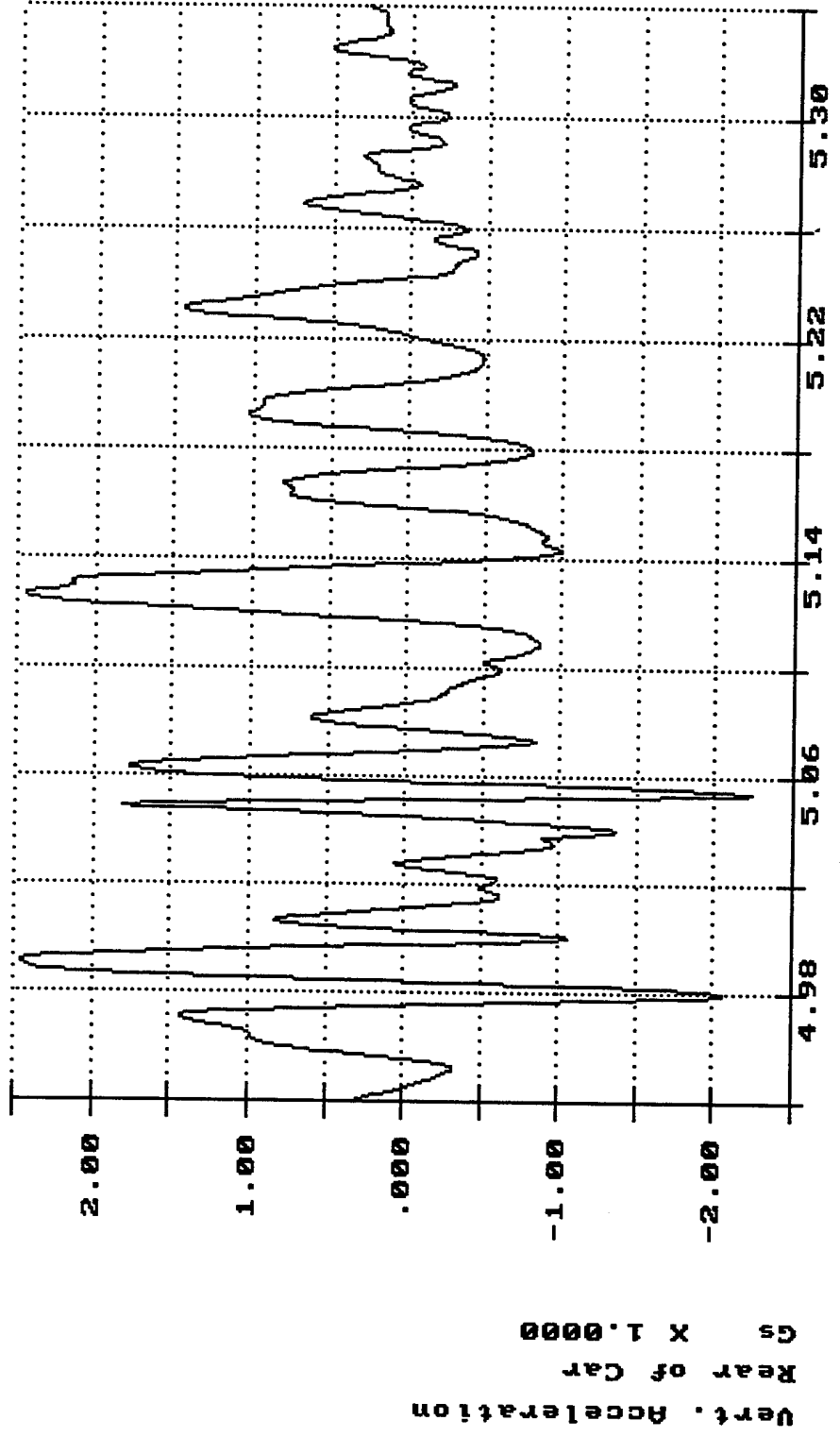

R.I. of FAPP, Impact 3: 8.1+ MPH Aug 17 09:57:30 1994

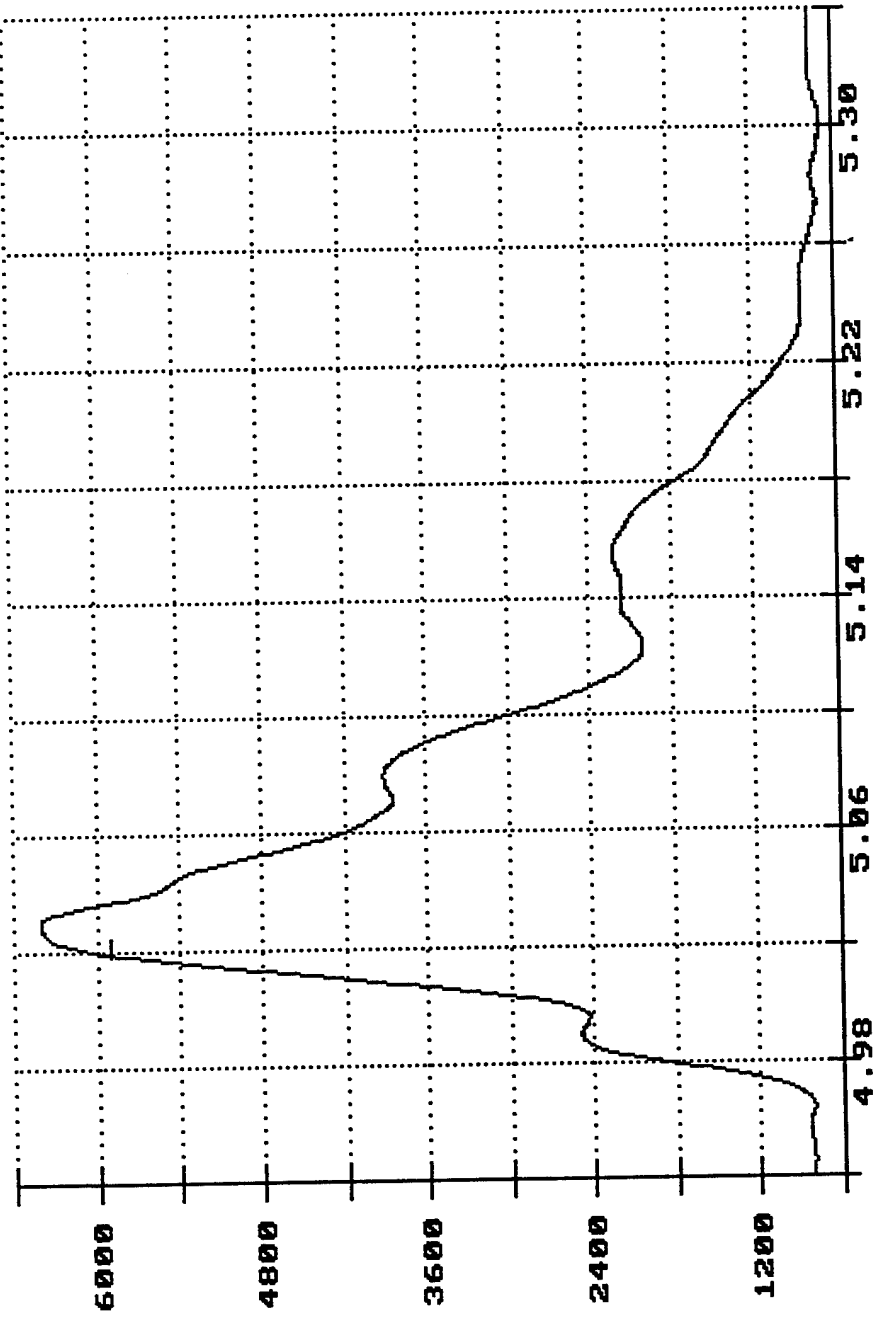

10K Load Cell
Top Left
LBS X 1.0000

Time of Sample

Seconds X 1.0000

R.I. of FAPP, Impact 3: 8.1+ MPH Aug 17 09:57:30 1994

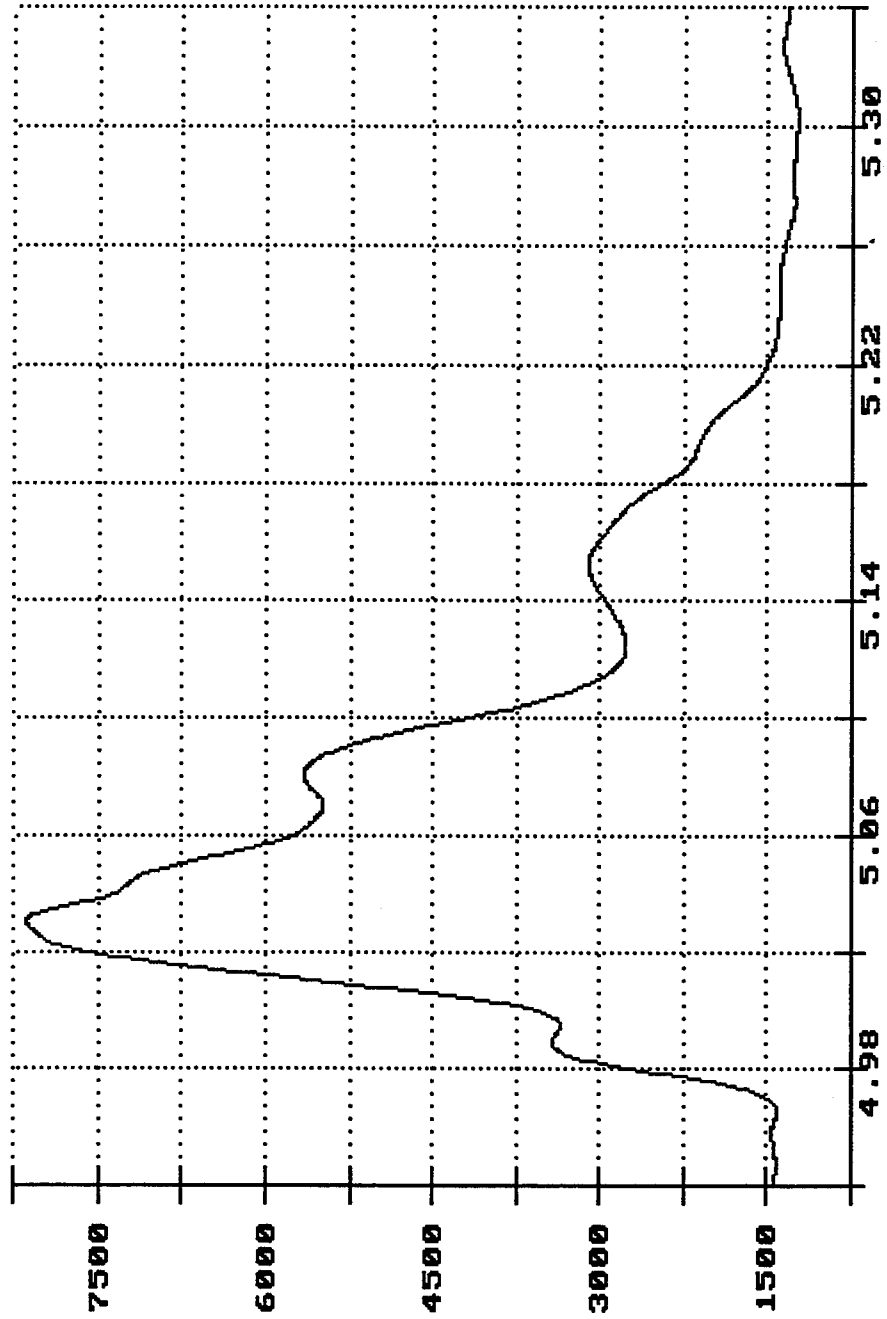

Time of Sample

Seconds X 1.0000

R.I. of FAPP, Impact 3: 8.1+ MPH Aug 17 09:57:30 1994

7

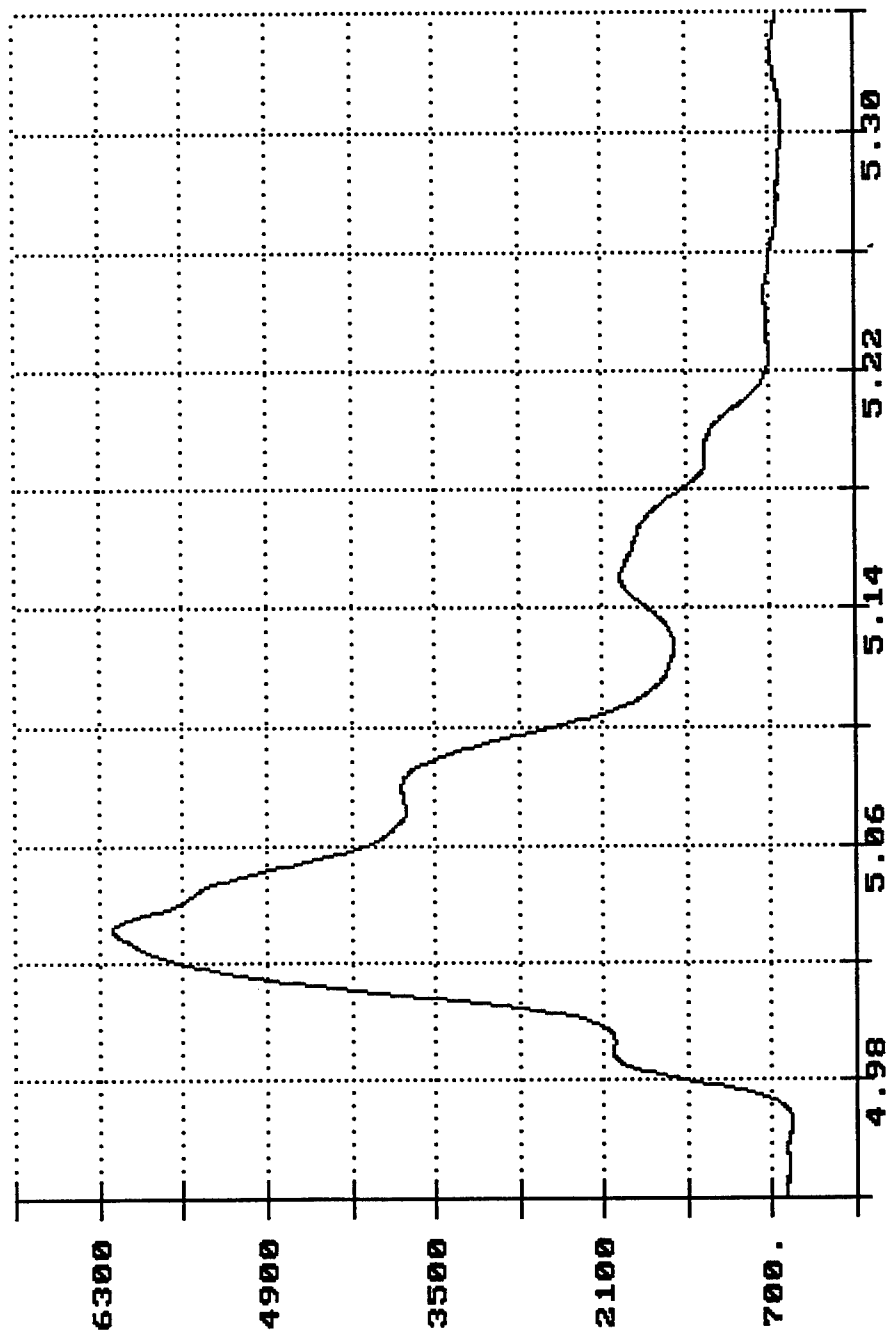

10K Load Cell
Top Right
LBS X 1.0000

Time of Sample
Seconds X 1.0000

R.I. of FAPP, Impact 3: 8.1+ MPH Aug 17 09:57:30 1994

7

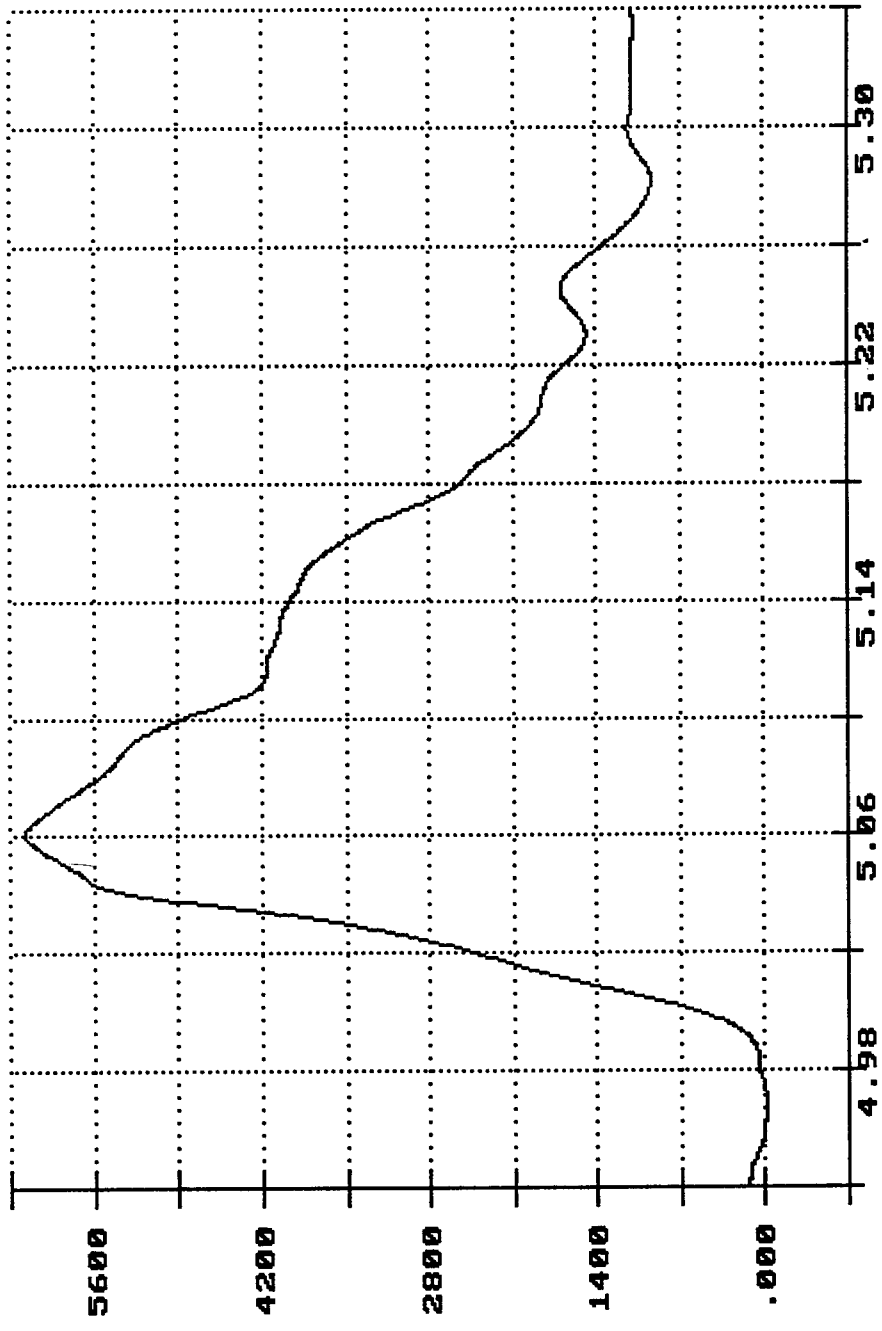

10K Load Cell
Bottom Left
LBS X 1.0000

Time of Sample
Seconds X 1.0000

R.I. of FAPP, Impact 3: 8.1+ MPH Aug 17 09:57:30 1994

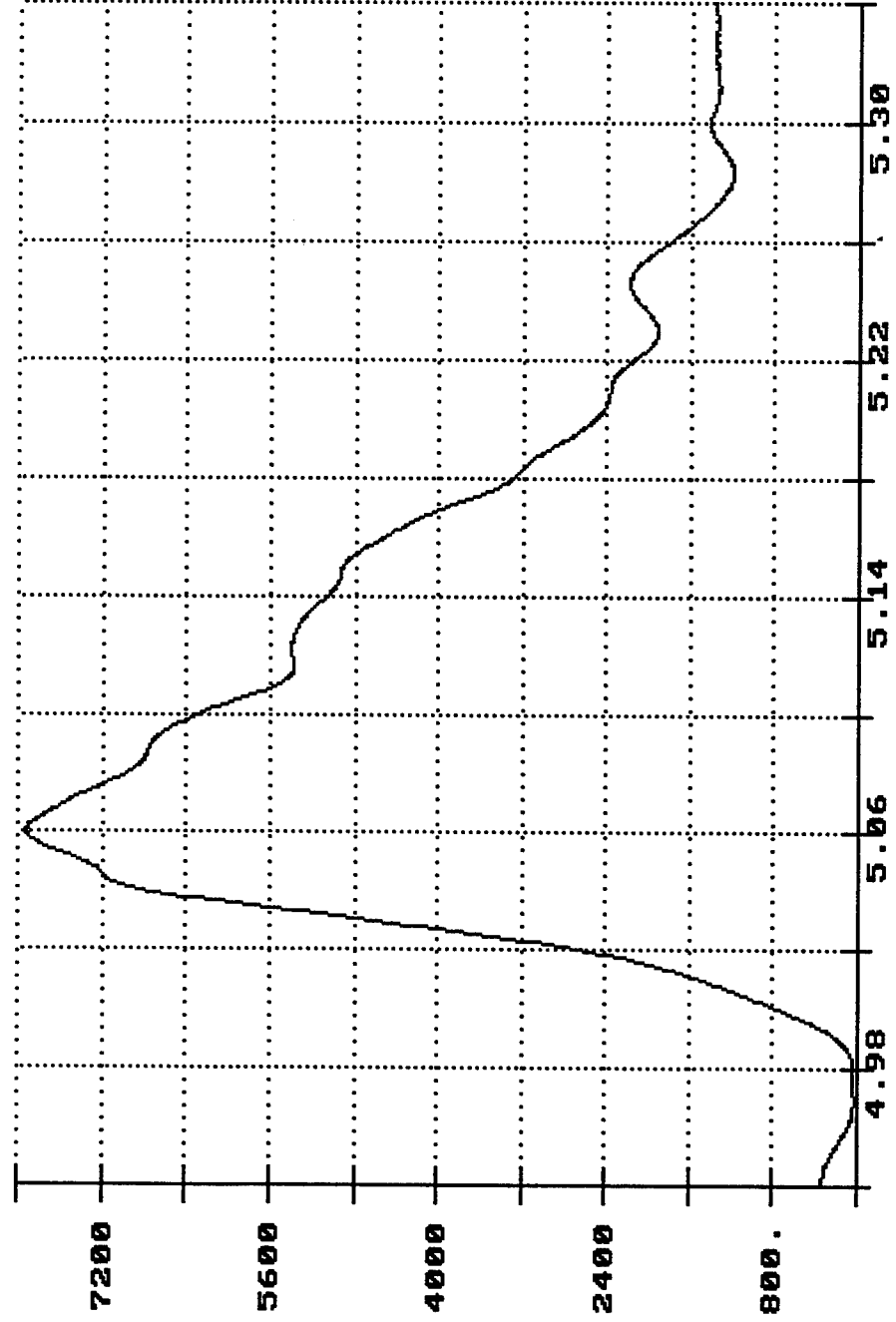

Time of Sample
Seconds X 1.0000

R.I. of FAPP, Impact 3: 8.1+ MPH Aug 17 09:57:30 1994

7

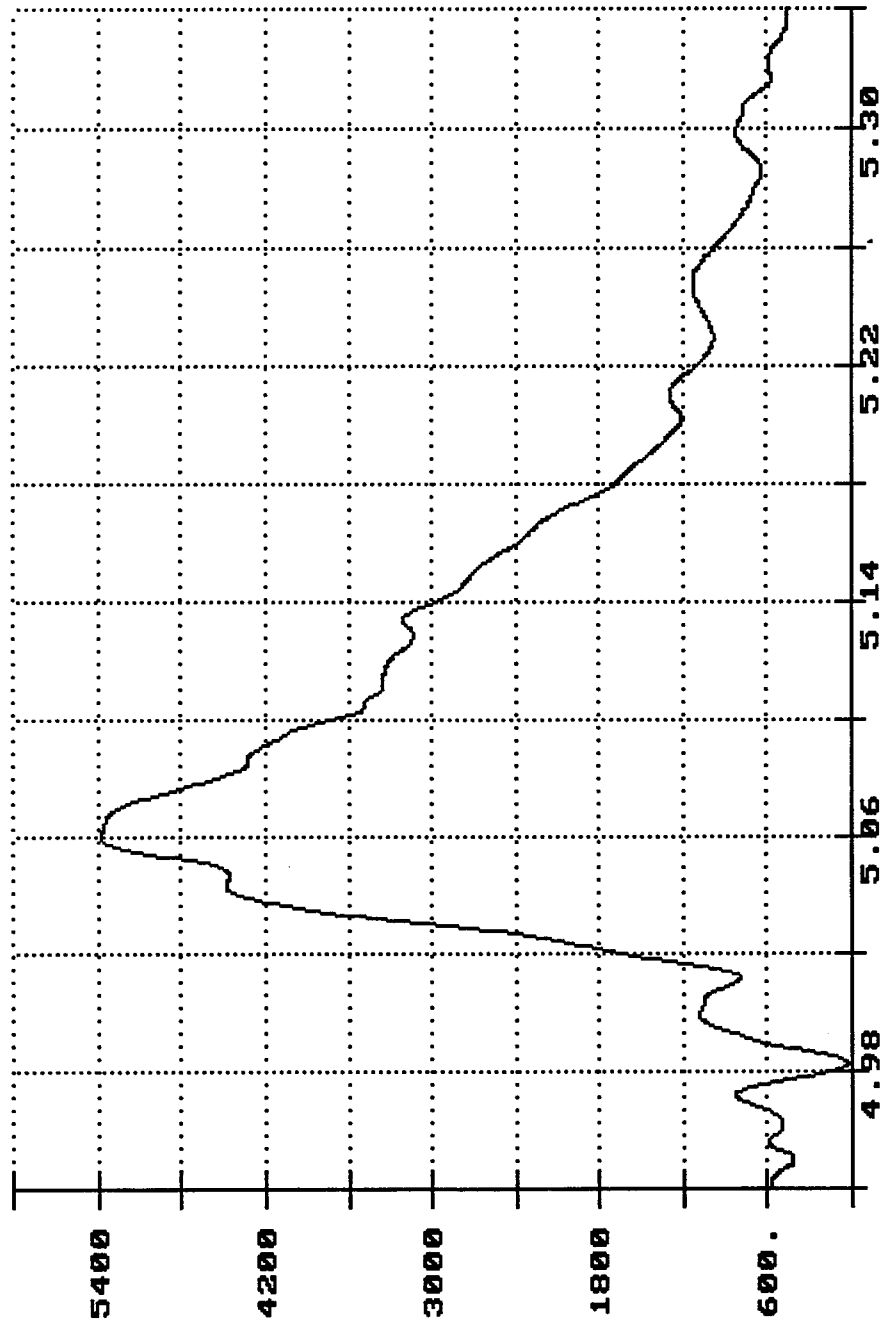

10K Load Cell
Bottom Right
LBS X 1.0000

Time of Sample
Seconds X 1.0000

R.I. of FAPP, Impact 4: 8.1+ MPH Aug 17 11:00:08 1994

7

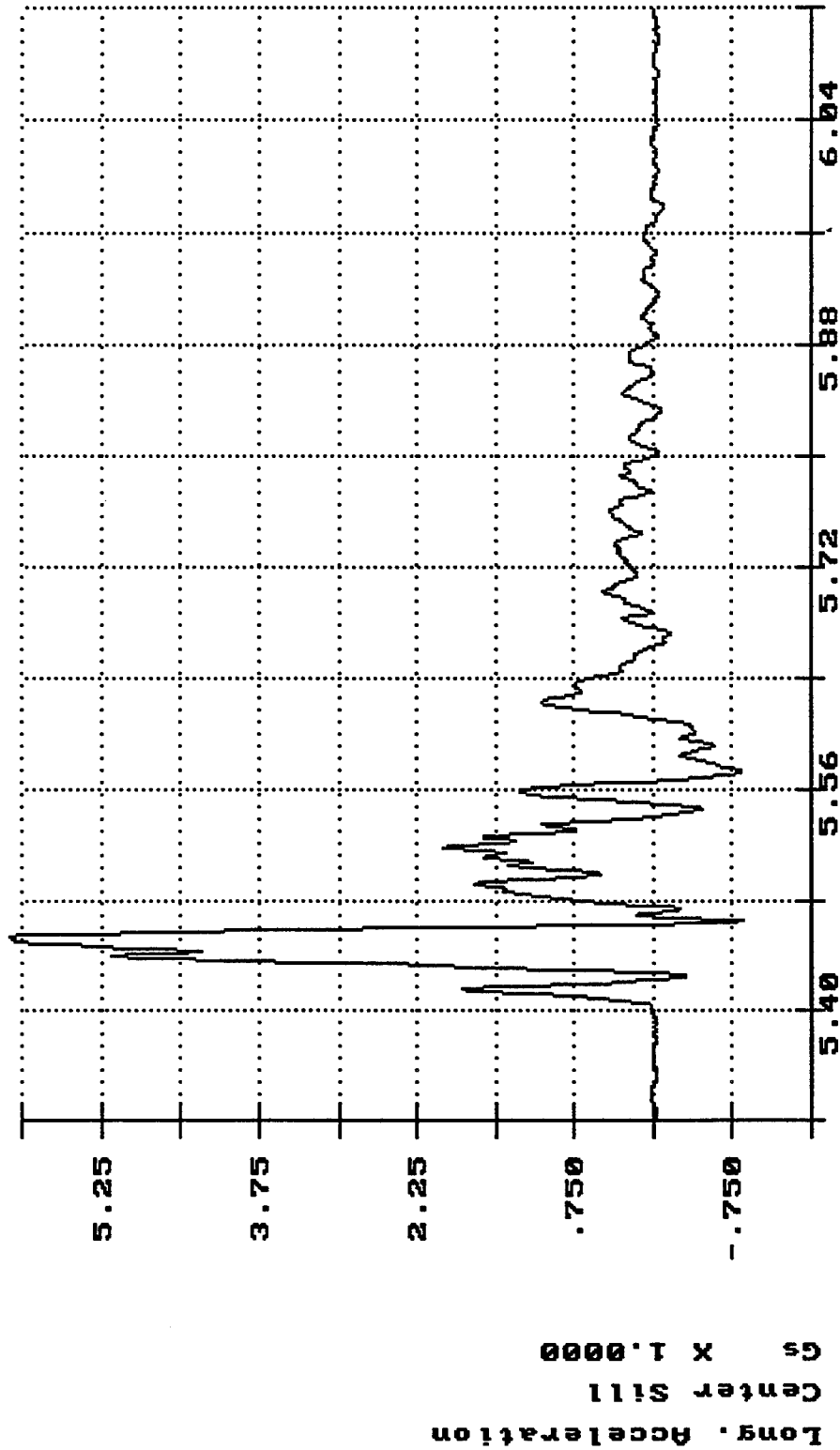

Time of Sample

Seconds X 1.0000

R.I. of FAPP, Impact 4: 8.1+ MPH Aug 17 11:00:08 1994

7

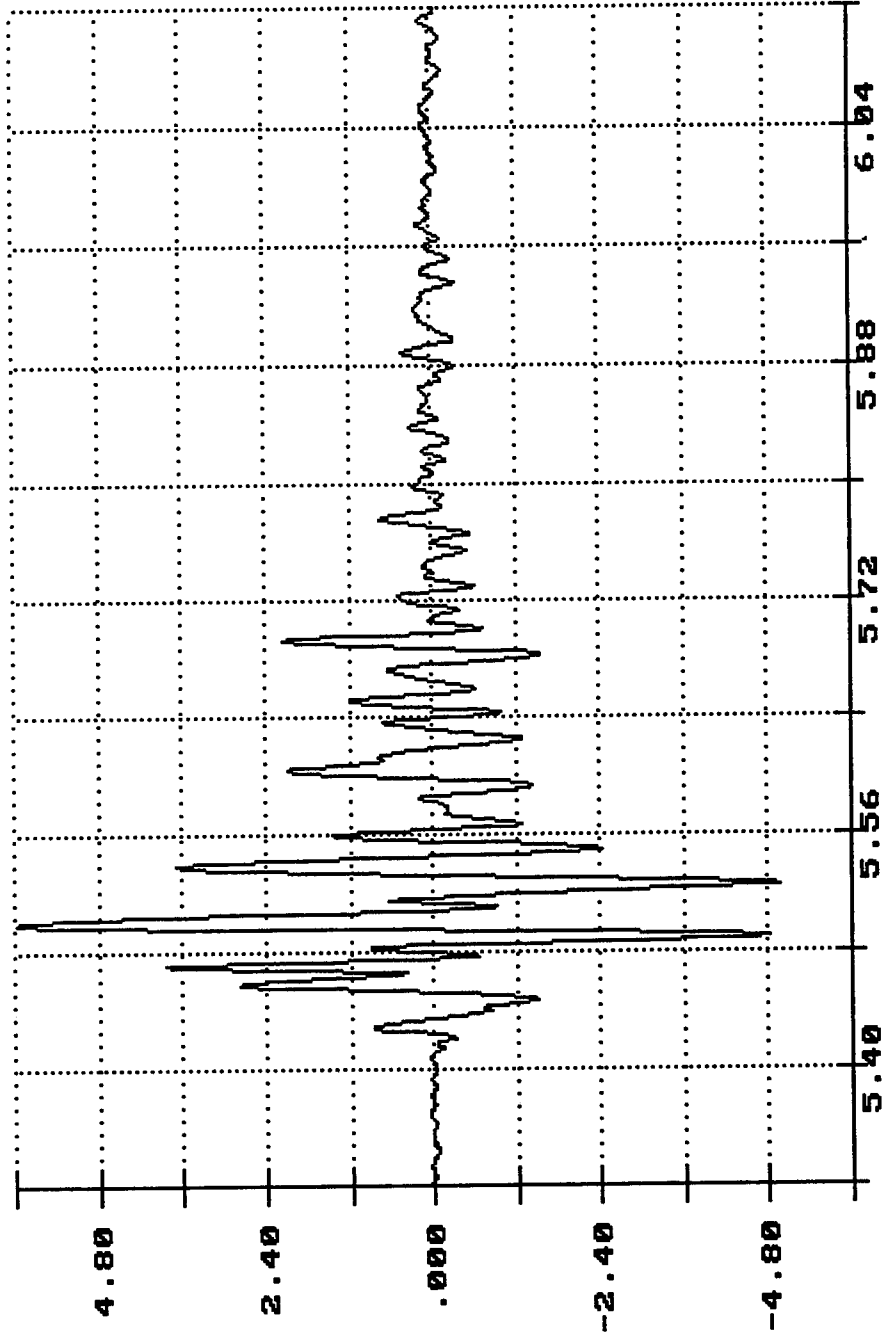

Vert. Acceleration
Center Sill
Gs X 1.0000

Time of Sample
Seconds X 1.0000

R.I. of FAPP, Impact 4: 8.1+ MPH Aug 17 11:00:08 1994

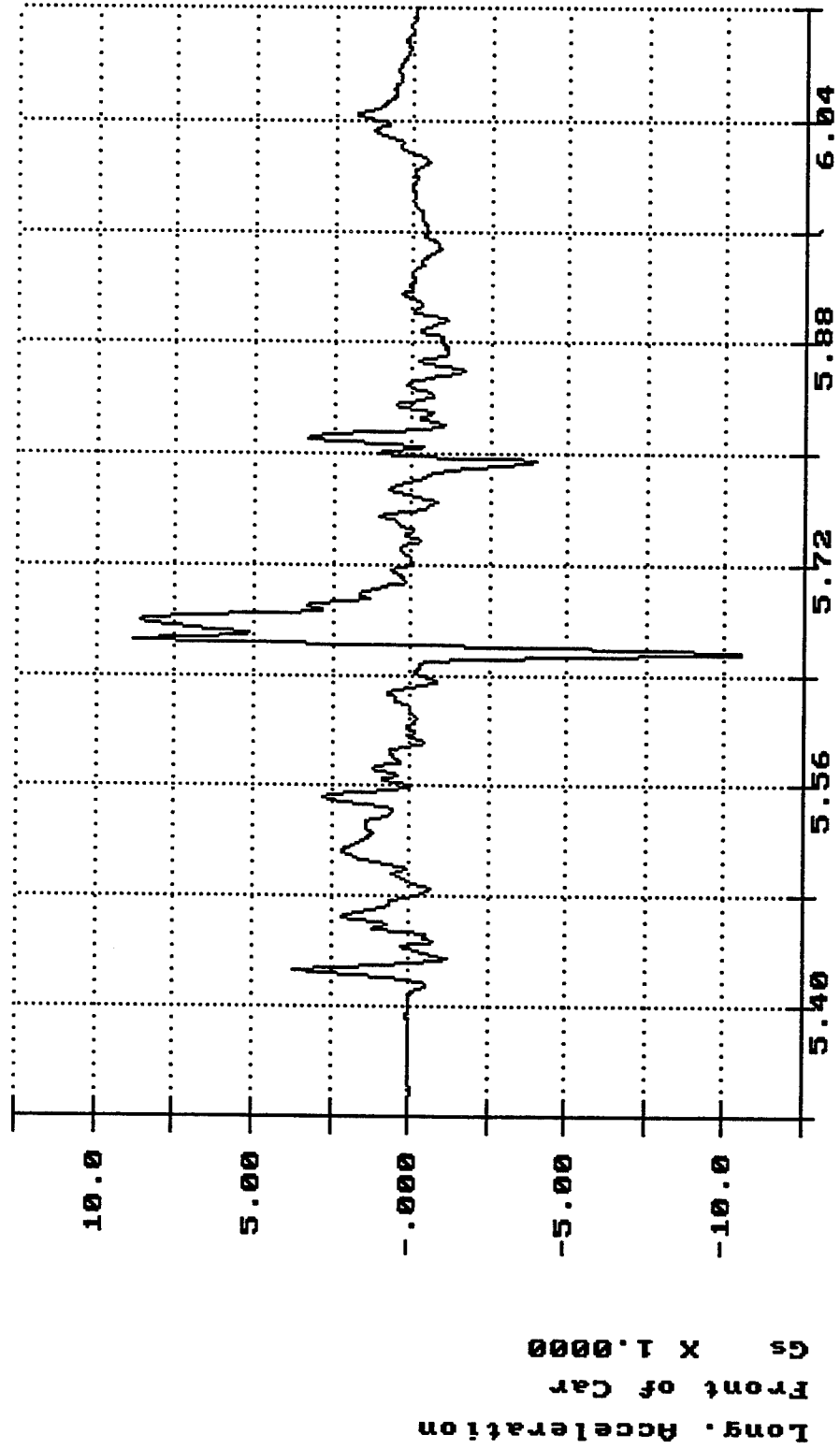

Time of Sample
Seconds X 1.0000

R.I. of FAPP, Impact 4: 8.1+ MPH Aug 17 11:00:08 1994

7

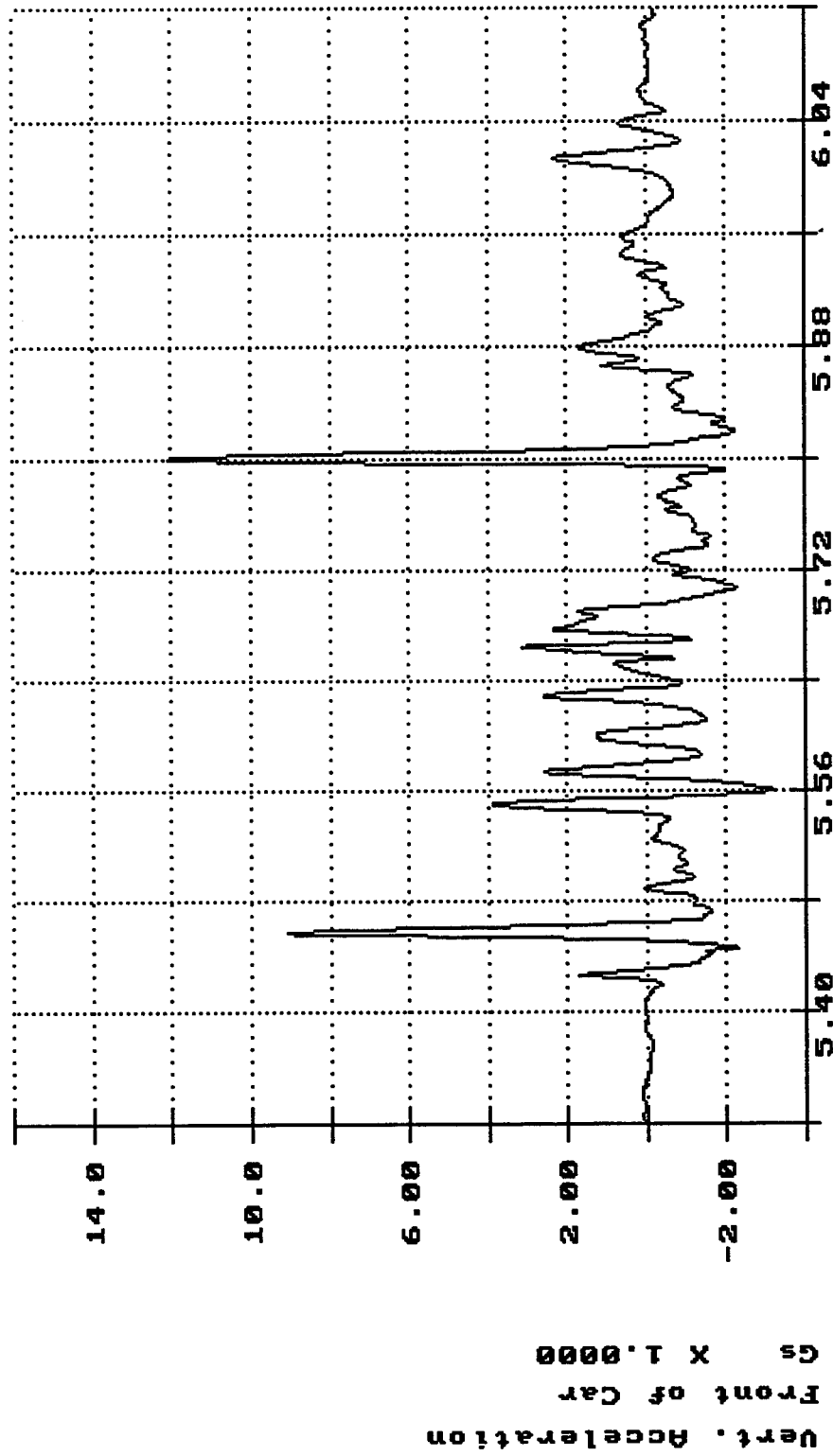

Time of Sample
Seconds X 1.0000

R.I. of FAPP, Impact 4: 8.1+ MPH Aug 17 11:00:08 1994

7

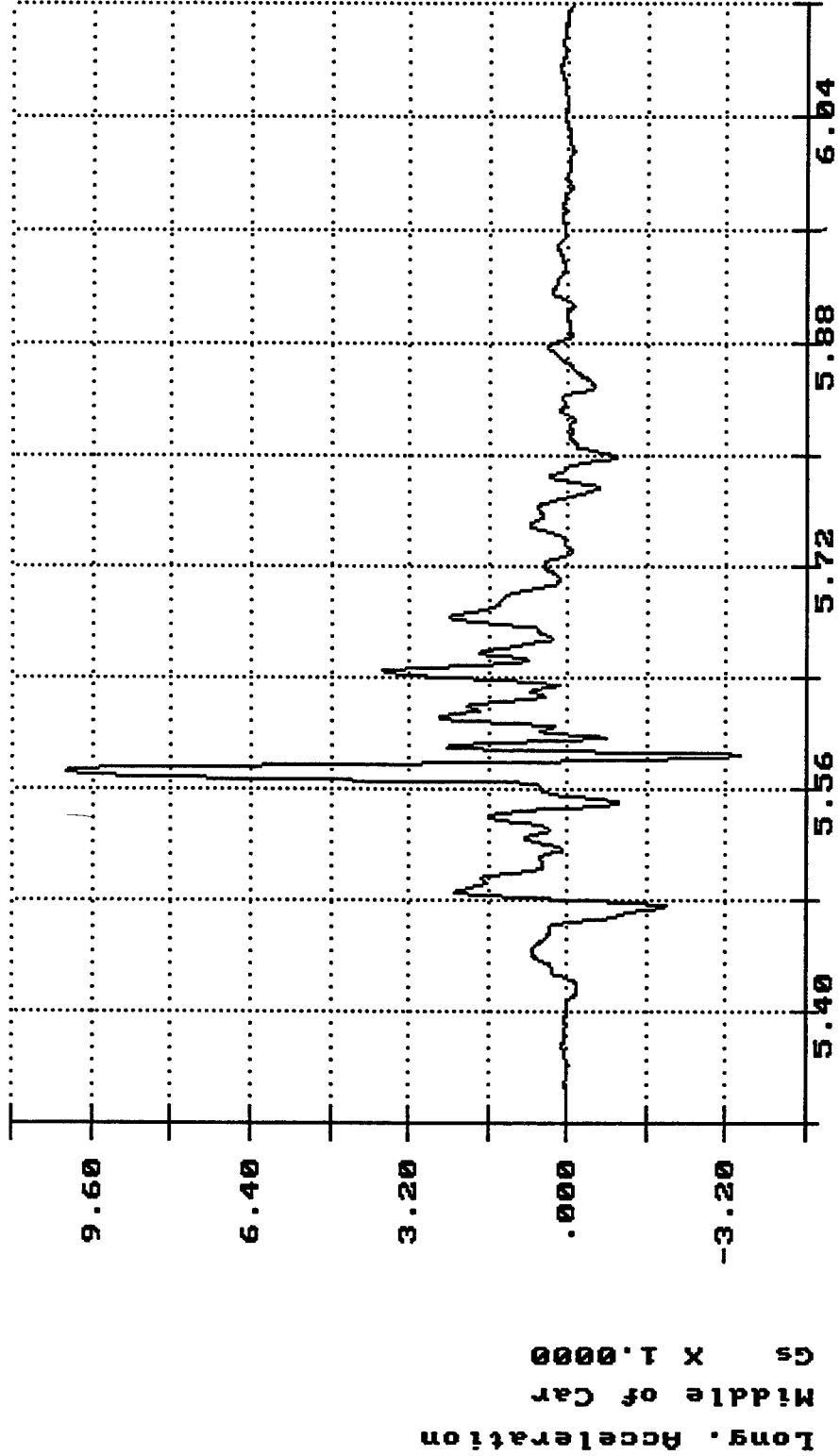

Time of Sample
Seconds X 1.0000

R.I. of FAPP, Impact 4: 8.1+ MPH Aug 17 11:00:08 1994

7

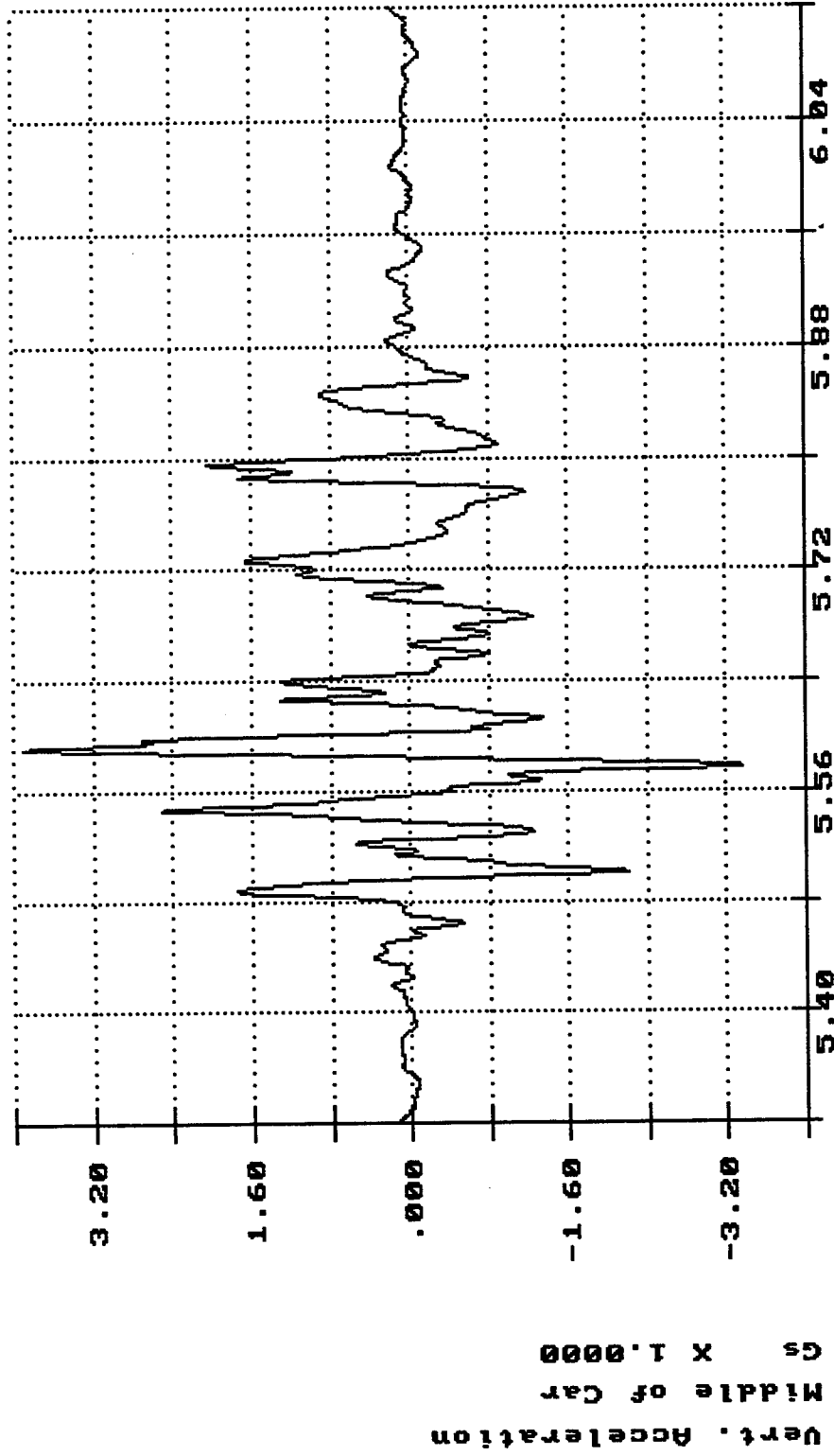

Time of Sample
Seconds X 1.0000

R.I. of FAPP, Impact 4: 8.1+ MPH Aug 17 11:00:08 1994

7

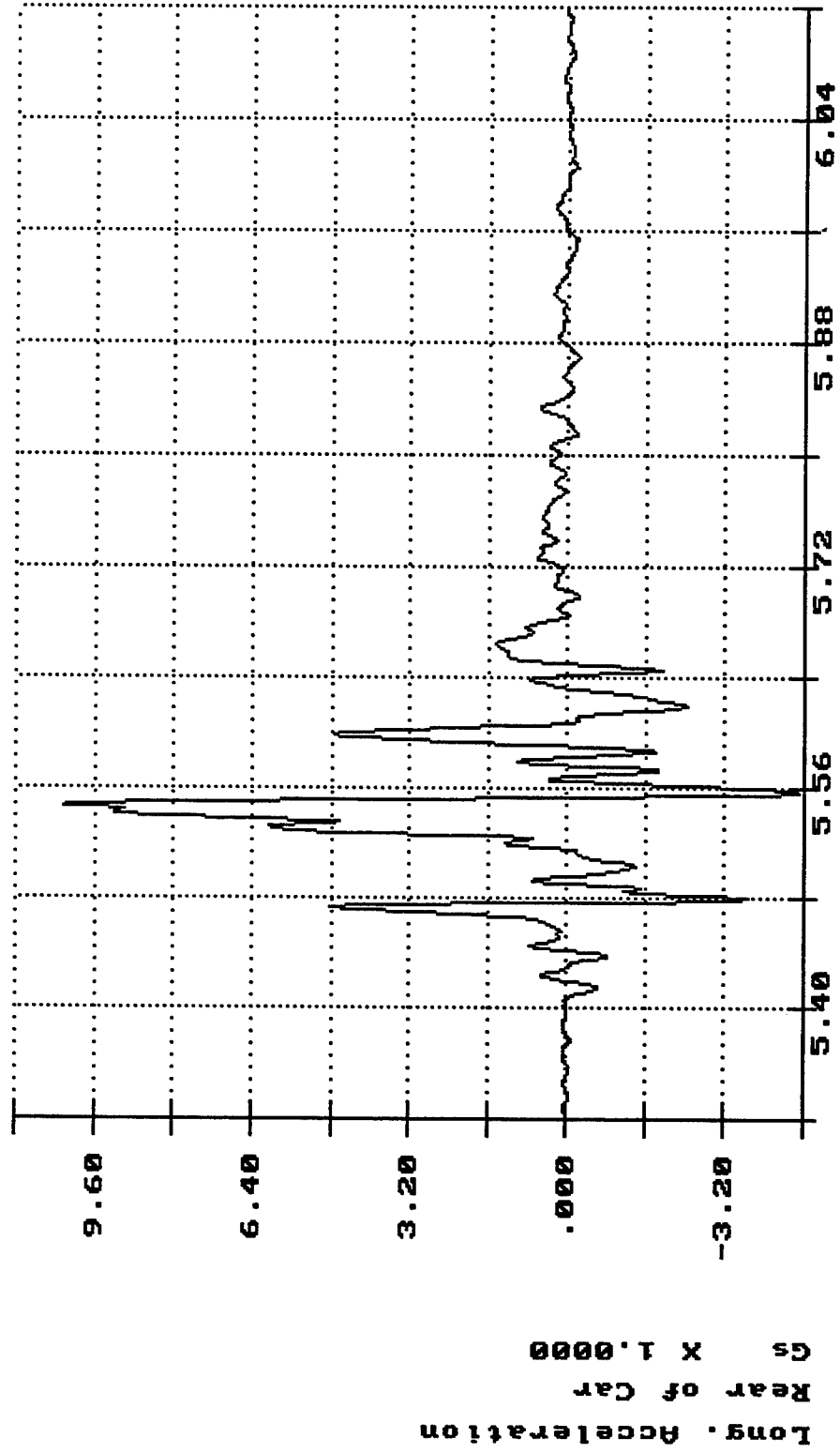

Time of Sample
Seconds X 1.0000

R.I. of FAPP, Impact 4: 8.1+ MPH Aug 17 11:00:08 1994

7

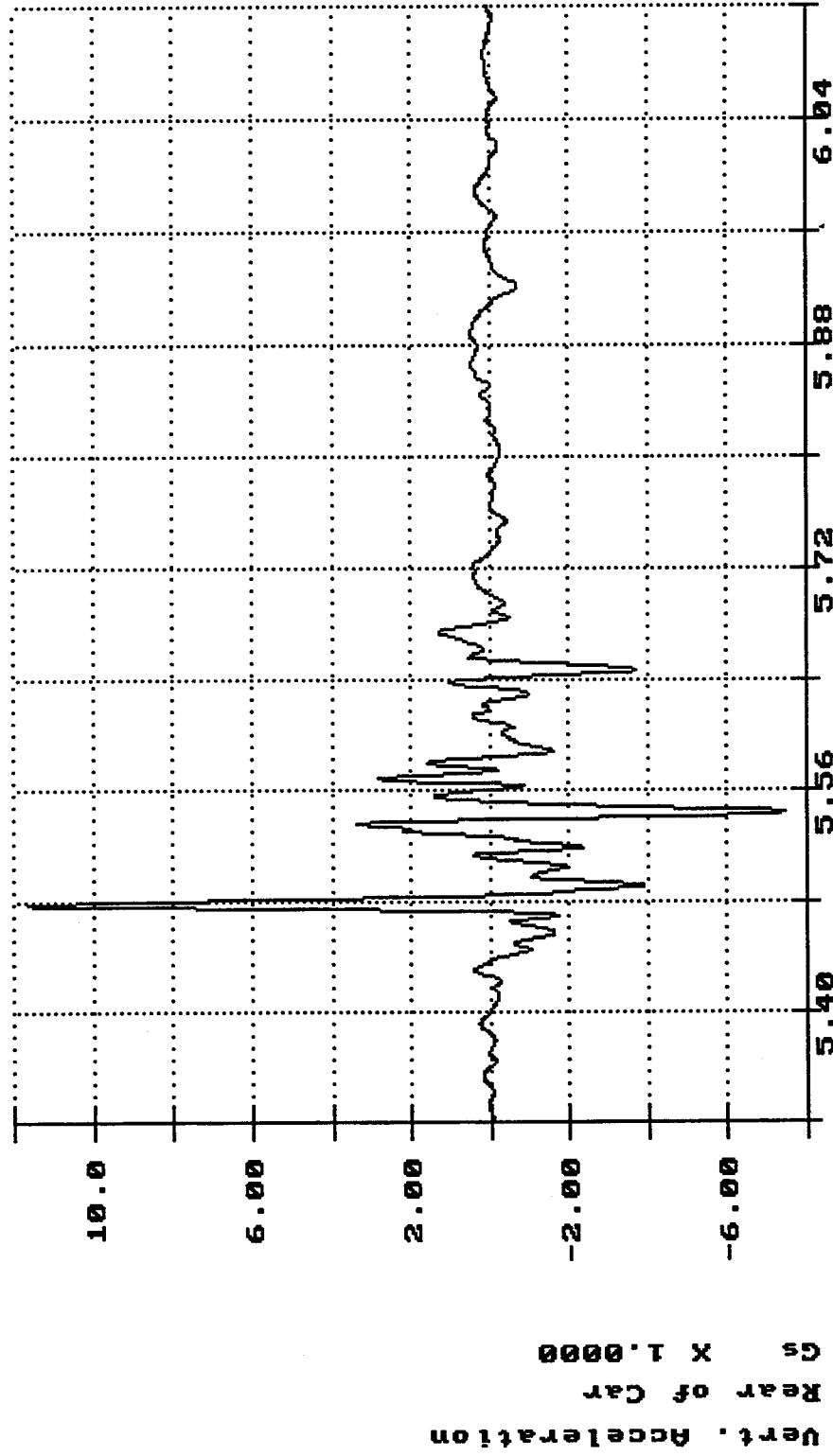

Time of Sample
Seconds X 1.0000

R.I. of FAPP, Impact 4: 8.1+ MPH Aug 17 11:00:08 1994

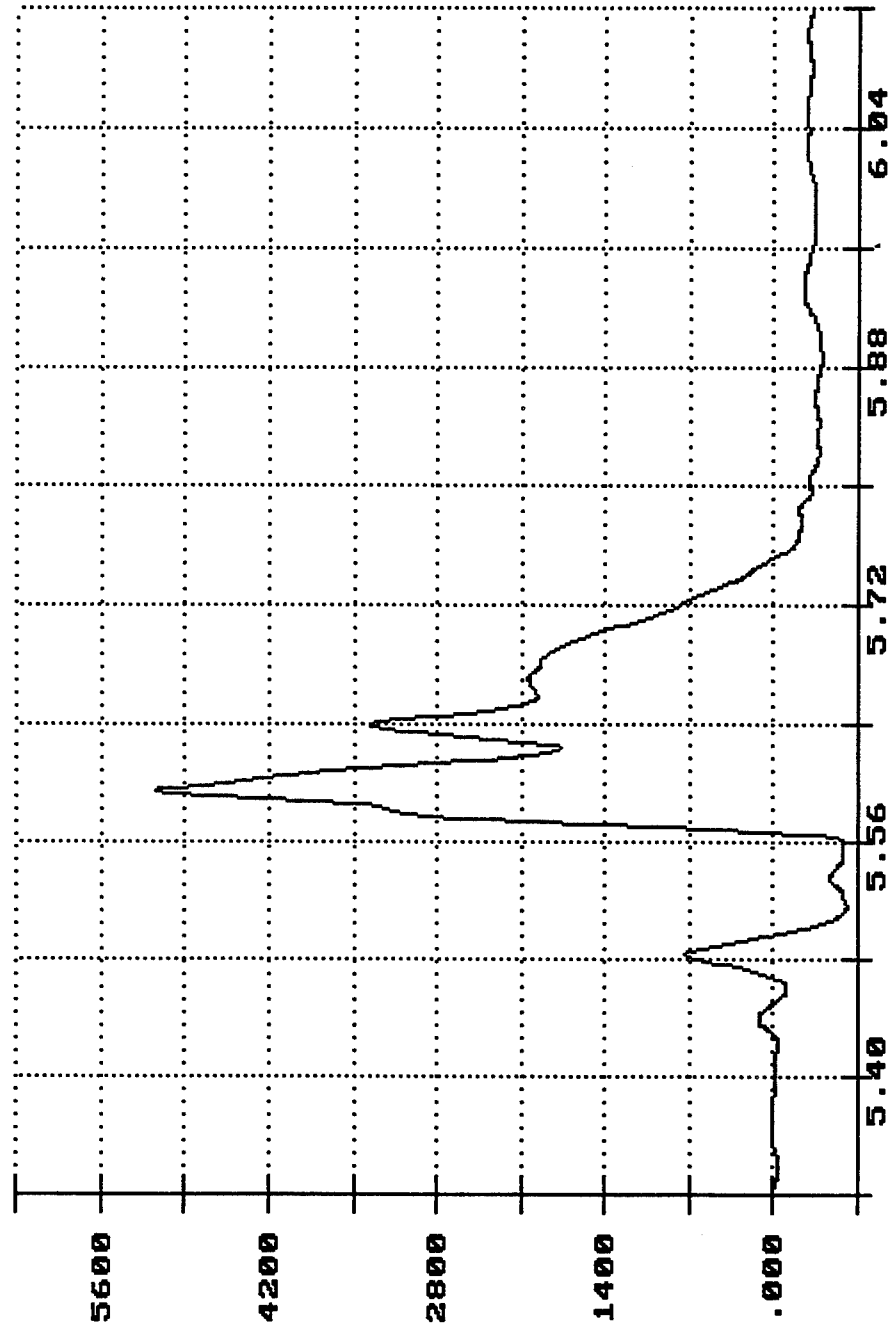

Time of Sample
Seconds X 1.0000

10K Load Cell
Top Left
LBS X 1.0000

R.I. of FAPP, Impact 4: 8.1+ MPH Aug 17 11:00:08 1994

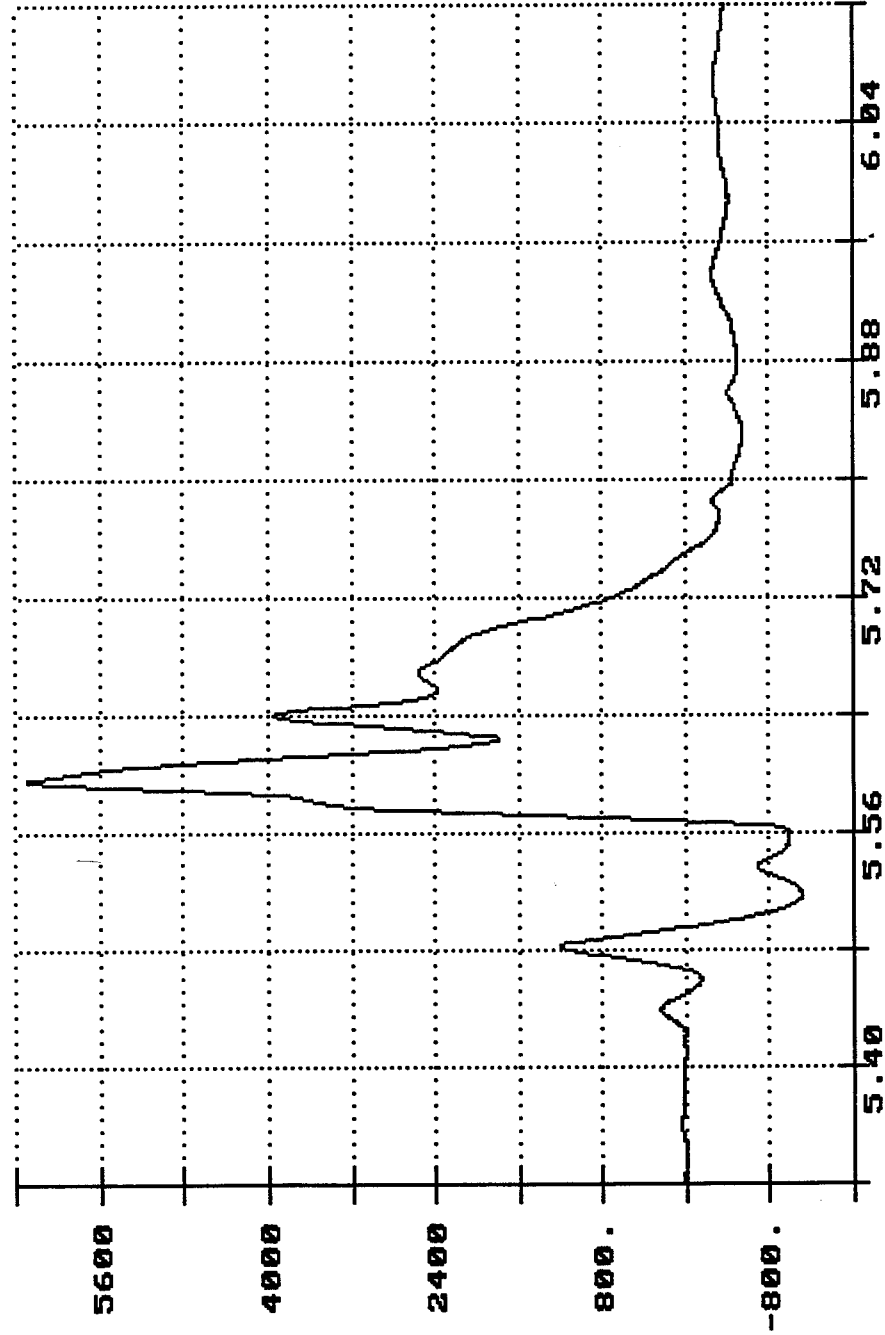

10X Load Cell
Top Center
LBS X 1.0000

Time of Sample
Seconds X 1.0000

R.I. of FAPP, Impact 4: 8.1+ MPH Aug 17 11:00:08 1994

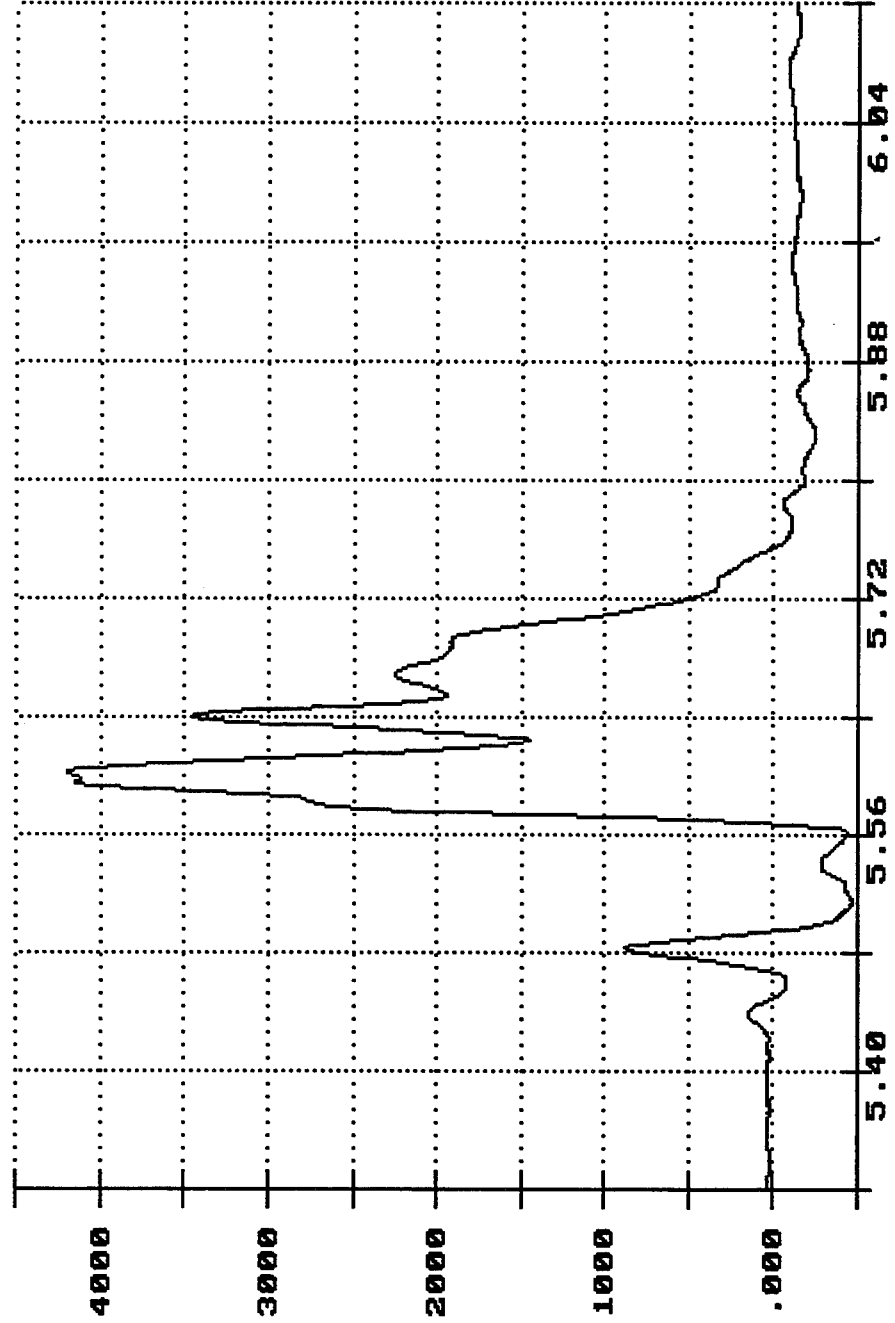

Time of Sample
Seconds X 1.0000

R.I. of FAPP, Impact 4: 8.1+ MPH Aug 17 11:00:08 1994

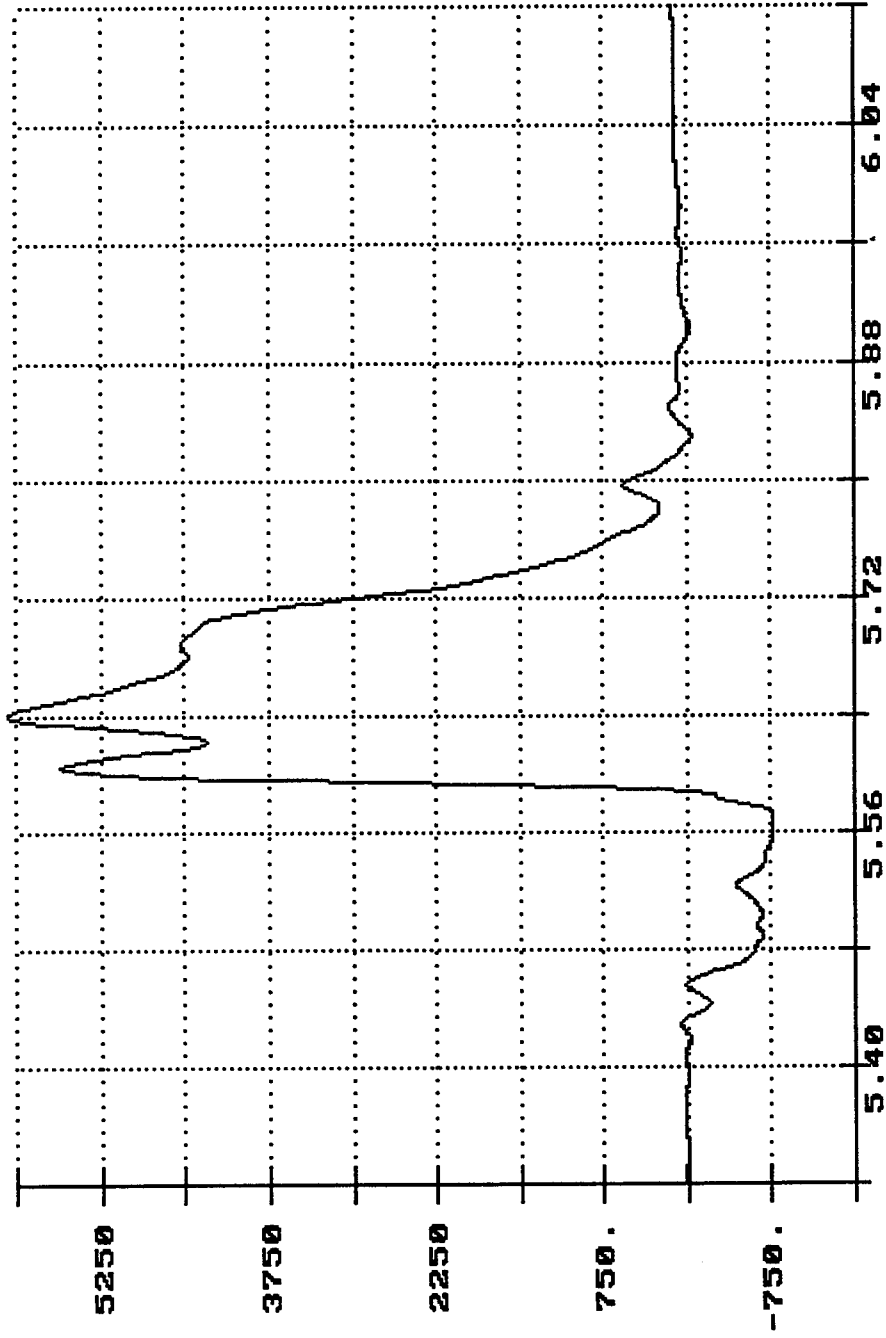

10K Load Cell
Bottom Left
LBS X 1.0000

Time of Sample
Seconds X 1.0000

R.I. of FAPP, Impact 4: 8.1+ MPH Aug 17 11:00:08 1994

7

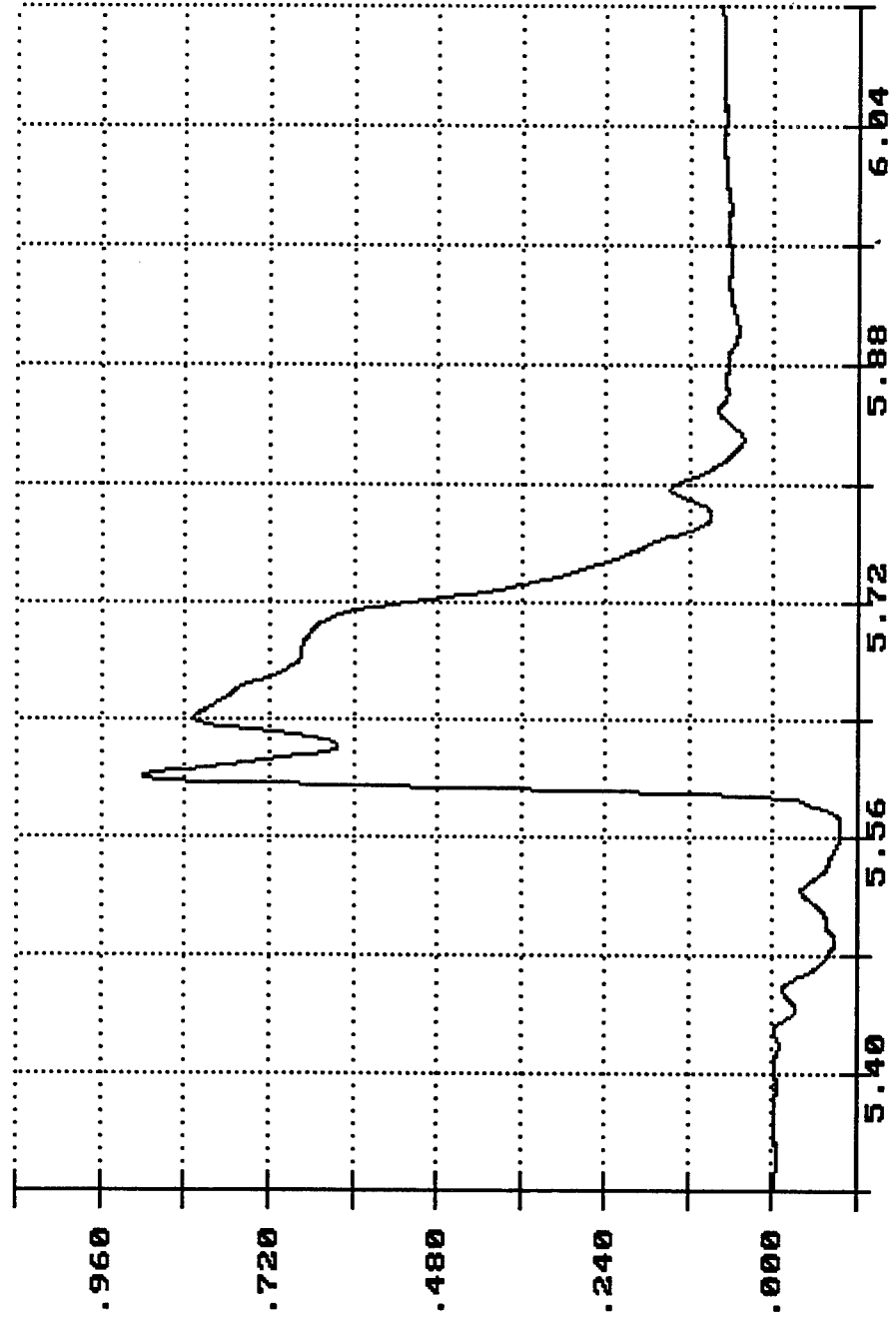

10K Load Cell
Bottom Center
LBS X 10000.0000

Time of Sample
Seconds X 1.0000

R.I. of FAPP, Impact 4: 8.1+ MPH Aug 17 11:00:08 1994

7

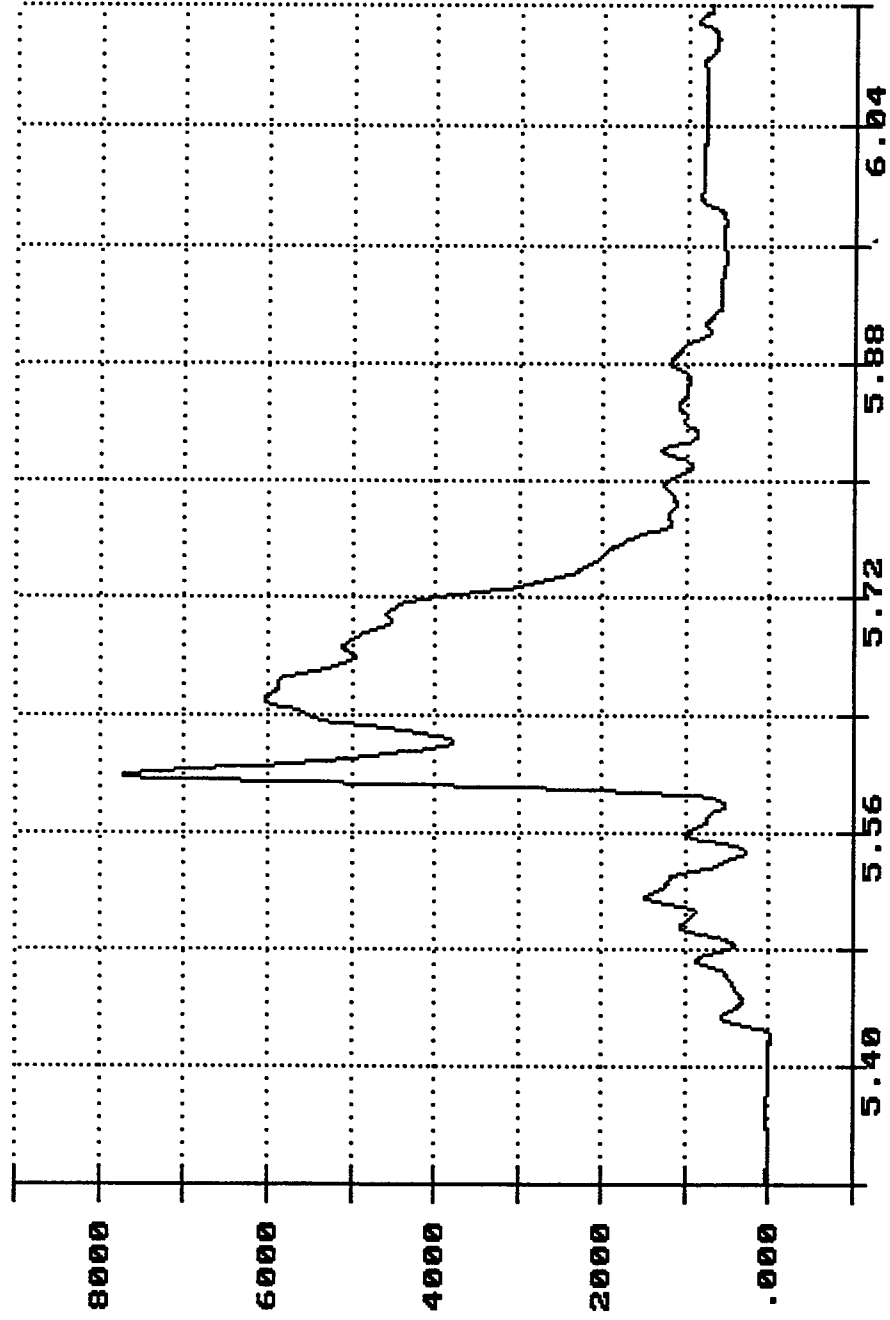

10K Load Cell
Bottom Right
LBS X 1.0000

Time of Sample
Seconds X 1.0000

PART 8

DRAWING

TEST PLAN NO. 4

155MM PROJECTILES PACKED 8 PER METAL PALLET

THIS 4-PAGE DOCUMENT DELINEATES THE REQUIRED BLOCKING AND BRACING PROCEDURES TO BE USED IN THE LOADING OF THE NEWLY-DEVELOPED FIELD ARTILLERY METAL PALLET FOR THE 155MM PROJECTILES PACKED 8 PER PALLET. THERE ARE 12 METAL PALLETS IN THE TEST LOAD. THREE PALLETS ARE LOCATED AT EACH END OF THE CAR. TWO ARE ADJACENT TO EACH CENTER GATE POSITIONED WITH THE LENGTH (14-3/4") ACROSS THE CAR, AND ONE ADJACENT TO EACH OF THESE, POSITIONED WITH THE LENGTH LENGTHWISE IN THE CAR. BALLAST FOR THE REMAINDER OF THE LOAD IS 155MM PROJECTILES PACKED 8 PER LARGE WOODEN PALLET. THE ACCOMPLISHMENT OF THIS TEST WILL DETERMINE IF THE REINFORCED PALLET UNITS ARE TRANSPORTABLE BY RAIL.

PALLET DIMENSIONS - - - 14-3/4" LONG BY 29-1/8" WIDE BY 39" HIGH (APPROX).

FOR MATERIAL SPECIFICATIONS, REFER TO US ARMY MATERIEL COMMAND (AMC) DRAWING 19-48-4012-5PE1000.

Prepared during August 1994 by:
U.S. Army Defense Ammunition
Center and School
ATTN: SMCAC-DET
Savanna, IL 61074-9639
POC: Ms. Laura A. Fleffer
DSN 585-8072/8927
Comm (815) 273-8072/8927
Fax 585-8811
E-mail: lfleffer@savanna-emhl.army.mil

William R. Frerichs
Chief, Transportation Engineering Division

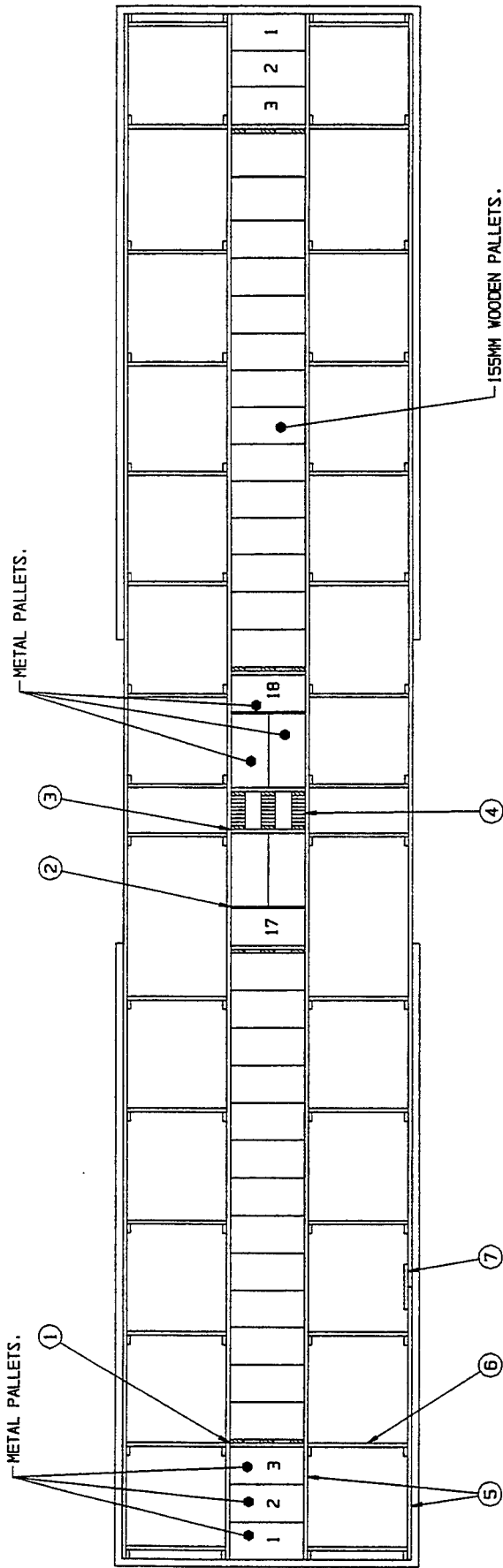

PLAN VIEW

50'-6" LONG BY 9'-6" WIDE BOXCAR.

KEY NUMBERS

- ① SEPARATOR GATE A (4 REOD). SEE THE DETAIL ON PAGE 3. POSITION SO THE HOLD-DOWN PIECE WILL BE UNDER THE METAL PALLET UNIT.
- ② SEPARATOR GATE B (2 REOD). SEE THE DETAIL ON PAGE 3. POSITION BETWEEN THE LENGTHWISE-POSITIONED AND CROSSWISE-POSITIONED METAL PALLET UNITS AND SO THE HOLD-DOWN PIECE WILL BE UNDER THE ALREADY-POSITIONED PALLET UNIT.
- ③ CENTER GATE (2 REOD). SEE THE DETAIL ON PAGE 4.
- ④ SOLID FILL, 6" WIDE BY 50" LONG BY THE THICKNESS REQUIRED TO PROVIDE A WEDGE FIT BETWEEN THE CENTER GATES, PIECES MARKED ③ (REQUIRED AT THREE PLACES). NAIL FIRST PIECE TO A VERTICAL PIECE OF THE CENTER GATE W/4-10d NAILS. LAMINATE EACH ADDITIONAL PIECE TO A PREVIOUSLY INSTALLED PIECE W/4-10d NAILS. SECURE THE LAST PIECE BY NAILING THRU THE VERTICAL PIECE OF THE OTHER CENTER GATE.
- ⑤ SIDE GATE (4 REOD). SEE THE DETAIL ON PAGE 4. RANDOM LENGTH MATERIAL MAY BE USED FOR THE HORIZONTAL PIECES. DO NOT MAKE A JOINT WITHIN THE DOOR OPENING: A FULL LENGTH PIECE, 12'-0" OR LONGER, MUST SPAN THE DOOR.
- ⑥ STRUT, 2" X 4" BY CUT TO FIT (REF: 39-1/2") (60 REOD). NAIL TO THE VERTICAL PIECES OF THE SIDE GATES, PIECES MARKED ⑤, W/2-10d NAILS AT EACH END.
- ⑦ SPLICE PIECE, 2" X 4" X 18" (AS REOD). CENTER ON A JOINT OF THE HORIZONTAL PIECES OF THE SIDE GATES, PIECES MARKED ⑤, AND NAIL TO THE HORIZONTAL PIECE W/3-10d NAILS AT EACH END.

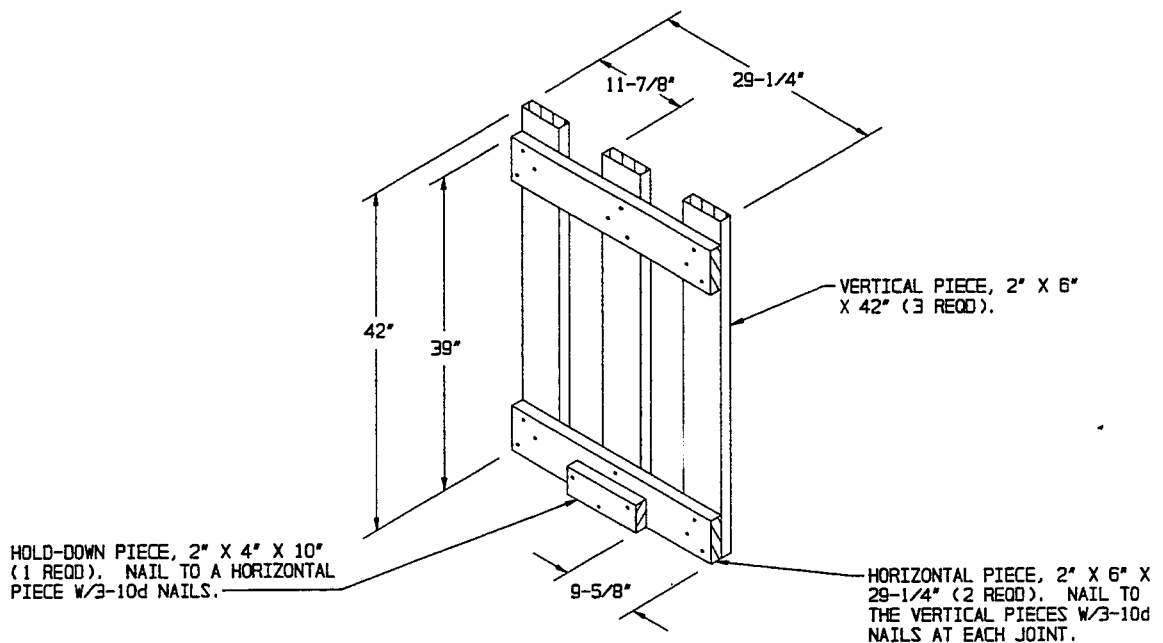

SEPARATOR GATE A

(2 REQD)

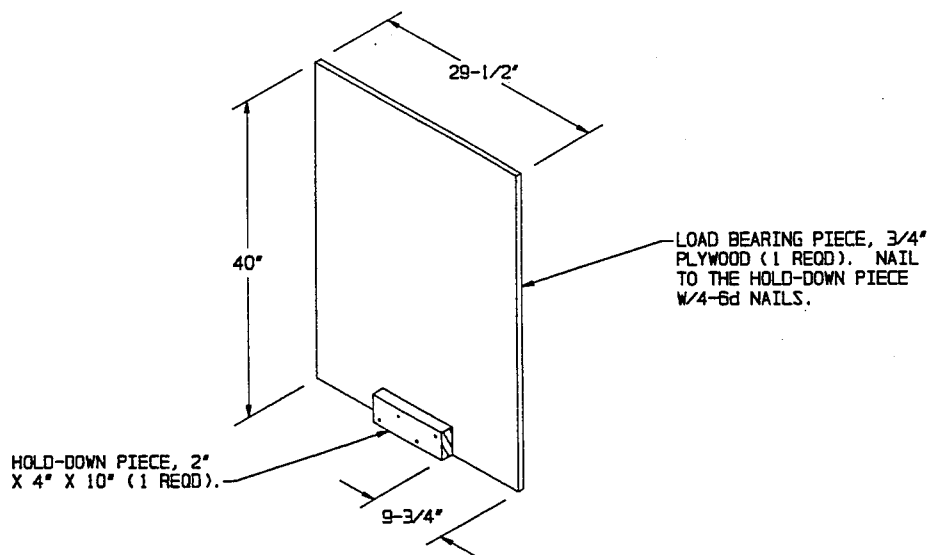

SEPARATOR GATE B

(2 REQD)

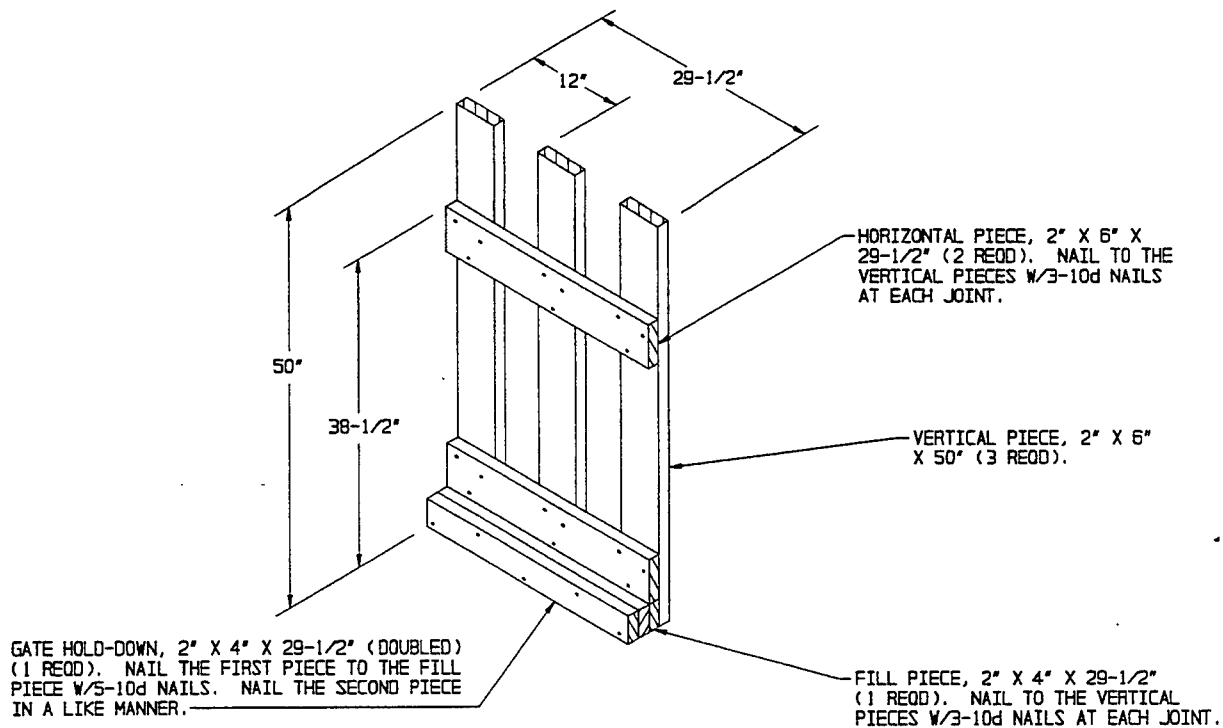

CENTER GATE

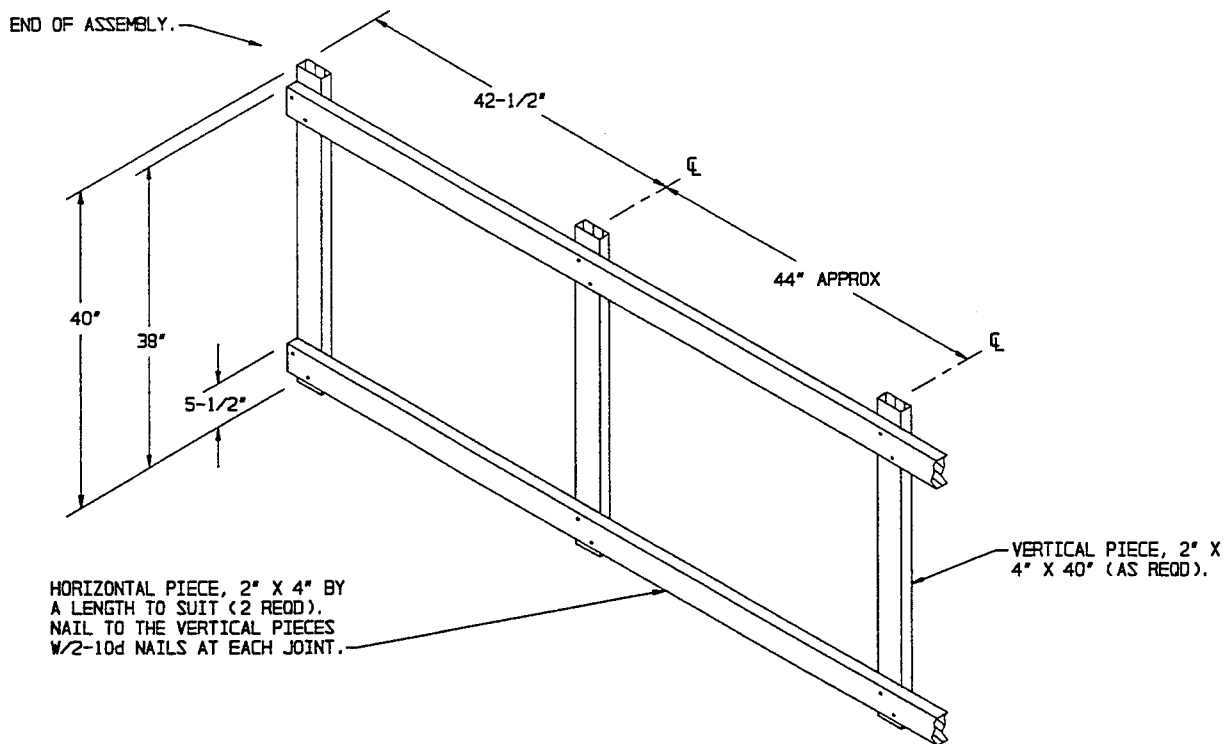

SIDE GATE