

# REPORT DOCUMENTATION PAGE

Form Approved  
OMB No. 0704-0188

Public reporting burden for this collection of information is estimated to average 1 hour per response, including the time for reviewing instructions, searching existing data sources, gathering and maintaining the data needed, and completing and reviewing the collection of information. Send comments regarding this burden estimate or any other aspect of this collection of information, including suggestions for reducing this burden, to Washington Headquarters Services, Directorate of Information Operations and Reports, 1215 Jefferson Davis Highway, Suite 1204, Arlington, VA 22202-4302, and to the Office of Management and Budget, Paperwork Reduction Project (0704-0188), Washington, DC 20503.

1. AGENCY USE ONLY (Leave blank)

2. REPORT DATE

14 March 1995

3. REPORT TYPE AND DATES COVERED

Phase I Final Report

4. TITLE AND SUBTITLE

Artificial Intelligence Techniques for Parts  
Obsolescence Prediction

5. FUNDING NUMBERS

Contract Number  
N00600-94-C-1827

6. AUTHOR(S)

Andrea L. Henke, Timothy P. Maher

7. PERFORMING ORGANIZATION NAME(S) AND ADDRESS(ES)

Stottler Henke Associates, Inc.  
916 Holly Road  
Belmont, CA 94002

8. PERFORMING ORGANIZATION  
REPORT NUMBER

FR001

9. SPONSORING/MONITORING AGENCY NAME(S) AND ADDRESS(ES)

Naval Regional Contracting Center  
Washington Navy Yard, Bldg. 200  
901 M Street S.E.  
Washington, D.C. 20374-5014  
Buyer/Code: Timothy McVady, Code PB1T

10. SPONSORING/MONITORING  
AGENCY REPORT NUMBER

n/a

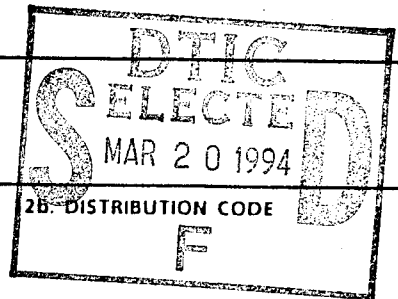

11. SUPPLEMENTARY NOTES

n/a

12a. DISTRIBUTION/AVAILABILITY STATEMENT

Approved for public release;  
distribution is unlimited

2b. DISTRIBUTION CODE

F

13. ABSTRACT (Maximum 200 words)

The primary objective of our Phase I effort was to explore the feasibility of a Navy-wide DMSMS prediction system and develop improved methods of obsolescence prediction. In pursuit of this goal, we investigated the DMSMS process at various Navy sites and identified and evaluated tools or processes currently in use. We decided to focus our efforts on microcircuit obsolescence prediction, because our study revealed that other types of parts are not nearly as significant a DMSMS problem. Furthermore, we concentrated on automating the largely manual obsolescence prediction currently performed by the MOM program. We used the artificial intelligence techniques of knowledge engineering, case-based reasoning, knowledge base development and object oriented programming to devise a solution to the obsolescence prediction problem. We also developed a preliminary design and functional description for a proactive Navy-wide DMSMS management system which will be developed in a Phase II effort. We implemented both these solutions in a prototype to prove their feasibility beyond a doubt. There is great potential for use of the Phase II system throughout the Navy, other branches of the military and in the commercial sector.

14. SUBJECT TERMS

DMSMS; parts obsolescence prediction; microcircuits;  
artificial intelligence; case based reasoning;  
knowledge engineering

15. NUMBER OF PAGES

97

16. PRICE CODE

n/a

17. SECURITY CLASSIFICATION  
OF REPORT  
unclassified

18. SECURITY CLASSIFICATION  
OF THIS PAGE  
unclassified

19. SECURITY CLASSIFICATION  
OF ABSTRACT  
unclassified

20. LIMITATION OF ABSTRACT

UL

# DISCLAIMER NOTICE



THIS DOCUMENT IS BEST QUALITY AVAILABLE. THE COPY FURNISHED TO DTIC CONTAINED A SIGNIFICANT NUMBER OF COLOR PAGES WHICH DO NOT REPRODUCE LEGIBLY ON BLACK AND WHITE MICROFICHE.

## TABLE OF CONTENTS

<u>Section</u>	<u>Page</u>
SECTION I: OVERVIEW	1
i.    Introduction	1
ii.   Summary of Results	1
iii.  Conclusions	2
SECTION II: DETAILED DESCRIPTION OF RESULTS	3
1.0    PROBLEM IDENTIFICATION	3
1.1    Background	3
1.2    Challenges	3
2.0    PHASE I TECHNICAL OBJECTIVES	4
3.0    ARTIFICIAL INTELLIGENCE METHODOLOGIES	5
3.1    Knowledge Engineering/Elicitation	5
3.2    Case Based Reasoning	6
3.3    Knowledge Based Development	7
3.4    Object Oriented Programming	8
4.0    PHASE I TASKS	8
4.1    Review Obsolescence Prediction Domain	8
4.2    Decide focus of feasibility study	9
4.3    Knowledge Elicitation	9
4.4    Detailed design of solution	9
4.5    Prototype implementation	9
4.6    Phase II Design	10
4.7    Evaluation of solution	10
4.8    End of project briefing and prototype demonstration	10
4.9    Final Report	10
5.0    TECHNICAL RESULTS AND PHASE I ACCOMPLISHMENTS	10

Accession For
NTIS CRA&I <input checked="" type="checkbox"/>
DTIC TAB <input type="checkbox"/>
Unannounced <input type="checkbox"/>
Justification _____
By _____
Distribution / _____
Availability _____
A-1

6.0	EVALUATION OF EXISTING PREDICTION METHODS/TOOLS	11
6.1	Evaluation Criteria	11
6.2	Tools/Methods Evaluated	12
6.2.1	Sites Interviewed	12
6.2.2	Tools/Methods	14
6.3	Assessment of the Navy's DMSMS Problem and Conclusions	21
7.0	SOLUTION: AUTOMATED OBSOLESCENCE PREDICTION AND PROACTIVE DMSMS MANAGEMENT	21
7.1	Description of our Solution	21
7.1.1	Automated Obsolescence Prediction	21
7.1.2	DMSMS Management System (DMS3)	22
7.2	Rationale for the Approach	26
7.3	Innovations and Intelligent Features	26
7.3.1	Innovations	27
7.3.2	Intelligent Features of the DMS3 Solution	28
7.4	Importance of the Solution	28
7.5	Issues	29
8.0	PROOF OF FEASIBILITY/PROTOTYPE DEVELOPMENT	30
8.1	Purpose of Prototype Development	30
8.2	Description of the Prototype Functionality	30
8.3	Results of Implementation	31
9.0	FUTURE RESEARCH AND DEVELOPMENT	32
10.0	CONCLUSIONS	34
	APPENDIX A - INITIAL KNOWLEDGE ENGINEERING QUESTIONS	35
	APPENDIX B - DETAILS OF THE PHASE I PROTOTYPE	36
B.1	Details of the Prototype Implementation	36
B.1.1	Predictive Family Identification	36
B.1.2	Assessment Algorithm	38
B.1.3	Major Classes in the Prototype	39
B.2	Prototype Demonstration Sequence/Screen Dumps	40
B.2.1	Demonstration Sequence	40
B.2.2	Screen Dumps	45
	APPENDIX C - DATA REQUIREMENTS AND SOURCES	95

## SECTION I: OVERVIEW

### i. Introduction

The primary objective of our Phase I effort was to explore the feasibility of a Navy-wide DMSMS prediction system and develop improved methods of prediction or devise methods where none currently exist. In pursuit of this goal, we have investigated the DMSMS process at Navy sites including SPCC, NUWC Keyport, NSWC Crane, and NAWC Indianapolis, as well as at DESC and Wright Patterson. We have researched the extent of the DMSMS problem for microcircuit and non-microcircuit parts, such as mechanical parts, and have identified and evaluated tools or processes currently in use. These tools include TACTech's AIM, GIDEP, Uwohali's ECOM, NUWC Keyport's Necad, MOM tools, and MOAT/MOSES for microcircuits, and HEDRS, Ships 3M, and Equipment Health Model for mechanical parts.

After an extensive survey of the DMSMS problem and existing tools, we decided to focus our efforts on microcircuit obsolescence prediction, because our study revealed that other types of parts are not nearly as significant a DMSMS problem. Furthermore, in the Phase I effort we concentrated on automating the largely manual obsolescence prediction currently performed by the MOM program. Our reasons for concentrating on automating the MOM prediction process include the fact that commercial prediction systems such as TACTech's AIM and Uwohali's ECOM do not cover all parts and thus cannot produce predictions for all parts and additionally that the MOM program is the only program in the Navy which performs its own comprehensive predictions.

We used the artificial intelligence techniques of knowledge engineering, case-based reasoning, knowledge base development and object oriented programming to devise a solution to the obsolescence prediction problem. We implemented this solution in a prototype to prove its feasibility beyond a doubt. We also developed a preliminary design and functional description for a Navy-wide DMSMS management system which will be developed in a Phase II effort. This system was also prototyped to demonstrate the proactive nature of our DMSMS management strategies and to establish the context of the prediction component.

### ii. Summary of Results

We accomplished all of our stated objectives and additionally implemented a prototype of the Phase II DMSMS system demonstrating the proactive capabilities and ideas for solution support. In summary, we produced the following results:

- Mechanical parts obsolescence is not a significant problem.
- Microcircuit parts obsolescence is largely solution oriented not predictive.
- Of the predictive systems/programs in existence, MOM is the most comprehensive.

- Data does not currently support CBR predictive techniques as proposed for Phase I because data is not standardized, there is missing information in data records and some data is unavailable.
- The MOM predictive process can be automated. We did it in a proof-of-concept prototype. CBR can be used to identify the predictive family so MOM's \$1 Million trends study can be used. A knowledge based obsolescence evaluation can be performed. Where automation breaks down, the system can request specific missing information and complete the evaluation.
- We identified the structure, standards and required information for collection of new data to allow more of the MOM process to be automated, CBR for obsolescence prediction and even more sophisticated data analysis and trends forecasting
- Designed and implemented a prototype of a comprehensive DMSMS Management System for proactive management of obsolescence and support for solutions. This system permits integration of relevant databases and can potentially include other parts data such as mechanical and electronic, along with microcircuit parts.

### iii. Conclusions

In Phase I, we applied our AI expertise to the problem of obsolescence prediction and DMSMS management. We developed an innovative solution to obsolescence prediction by automating the MOM evaluation process. Further, we designed a proactive DMSMS management system which incorporates the prediction techniques and gives users capabilities well beyond any current expectations. The automated prediction process results in faster DMSMS processing and allows engineers to deal with the hard problems and prioritize their tasks. It is proactive so that obsolescence issues are identified earlier. It provides guidance through the solution process and coordination of solution efforts. It may be straightforwardly expanded to include other types of parts, and it is owned and controlled by the Navy.

Through implementation of both of these solutions in a prototype, we proved the feasibility of our methods beyond a doubt. This effort laid the groundwork for the successful implementation of the fully functional DMSMS Management System in Phase II.

## **SECTION II: DETAILED DESCRIPTION OF RESULTS**

### **1.0 PROBLEM IDENTIFICATION**

#### **1.1 Background**

The diminishing manufacturing sources and material shortages (DMSMS) problem has been a concern for many years throughout both military and commercial sectors. Weapon systems' components become obsolete as technology advances. Manufacturers cease production of parts over time. Management of microcircuit, electronic and mechanical parts, from design to acquisition, storage, use, and ultimate disposal, has very large associated costs in terms of tracking and solution.

In recent years, more microcircuit and electronic parts have been used in new weapon system designs and redesigns, resulting in shorter part life cycles as the technology rapidly advances. The changing world economy and financial realities at home have decreased the defense budget. This has meant that weapon systems are in use longer than expected and commercial industries are increasingly independent of the government and cater less to its specific needs. Coping with an increasing number of obsolete parts, a shorter time frame for solutions and a restricted budget, demands a greater emphasis on obsolescence prediction and proactive parts management, and better communication and coordination of solutions. Parts obsolescence prediction has been the focus of our Phase I effort.

#### **1.2 Challenges**

Obsolescence prediction strategies are essential to effective parts management and can yield significant cost avoidance advantages. Calculating the useful life of a part is as much an art as a science. The key factors must be identified and then combined using an assortment of principles and rules to produce an obsolescence estimate. Even the problem of determining these significant factors can be quite complex. For example, it is generally accepted that technology, function, manufacturer and suppliers are important factors affecting obsolescence. Only recently has it been discovered that a rise in the price per part is also an indication of impending obsolescence. Analysts have also found that along with the number of parts suppliers, the rate at which the number drops is equally significant. Only through thorough analysis can these and other non-obvious factors be identified. Once this has been accomplished, the task of determining the principles by which these factors should be combined to produce accurate estimates is even more difficult, since there are few "hard and fast" rules to follow. Thus, there are significant benefits from a decision aiding tool which would determine these factors and combine them appropriately to produce overall obsolescence predictions.

Proactive DMSMS management is also inhibited by the distributed nature of the problem and the huge quantities of data involved. DMSMS is tracked at various sites (with some duplication of effort) using different techniques and database management systems. There are no standard data definitions for parts data and users generally cannot communicate across these databases. Data records are often incomplete or inconsistent. For example, part descriptions and technology fields are not always filled in, or if they are, they may use different terminology or abbreviations (e.g. LINE DRIVER / TRANSMITTER, DIFF and QUAD LINE DRIVER - DIFF (TS) both describe the same part in different databases). DMSMS is not tied electronically to weapon systems. Some parts data is unavailable because the government does not know the parts in "black box" components, or great effort is required to translate data or drawings to electronic form.

In a domain affecting the entire Department of Defense, where rapid responses are necessary and the cost of failure is high (LOT buys, retooling, private stockpiles, etc. are expensive), we find a primarily reactive DMSMS process. In general, the database management systems, obsolescence prediction techniques and DMSMS management protocol are not yet in place for efficient or comprehensive sharing of data and solutions.

Because of the great importance and significant cost of DMSMS management, the Navy could dramatically benefit from intelligent, automated parts obsolescence prediction and proactive DMSMS management. However, no tool currently exists which is both comprehensive and flexible enough to meet these needs. For this reason, the primary objective of our Phase I effort was to apply our Artificial Intelligence (AI) problem solving expertise to this problem and develop feasible solutions.

## 2.0 PHASE I TECHNICAL OBJECTIVES

The overall Phase I objective was to prove that an effective method could be achieved for identifying the factors and principles that determine the useful life of a component, and combining them to produce a reliable obsolescence prediction. Success developing a proof-of-concept prototype for this method would allow for Phase II design of a full-scale system containing a complete case base of microcircuit, electronic and mechanical components used in U.S. military weapons systems, as well as more thorough interface design and end-user performance testing. Specifically, there were four Phase I objectives:

1. Analyze current obsolescence prediction techniques, and collect an initial case base of components. Investigate the use of case based reasoning for predicting parts obsolescence.
2. Implement a proof-of-concept prototype obsolescence prediction system using a broad selection of components as cases.
3. Develop and test several obsolescence prediction algorithms in the prototype.

4. Design the full-scale Phase II prediction system: The culmination of the Phase I research is a complete functional specification of a parts obsolescence prediction system.

### 3.0 ARTIFICIAL INTELLIGENCE METHODOLOGIES

While we approached the parts obsolescence prediction problem with a number of innovative ideas and extensive experience in the field of AI and general problem solving, we did not wish to inappropriately impose a solution or methodology on the problem. Instead, we sought to first thoroughly understand the complexities of obsolescence prediction, the tools and techniques currently in use, and the Navy's future goals for DMSMS management. Using appropriate AI techniques, we could then tailor a solution to the problem. The AI methodologies we drew upon as we investigated the problem included knowledge engineering/elicitation techniques, case-based reasoning techniques, knowledge based development techniques and object oriented programming. Each of these methodologies is described in the following subsections.

#### 3.1 Knowledge Engineering/Elicitation

Knowledge engineering is the process of eliciting and organizing information from experts in a particular domain, in our case parts obsolescence prediction. Knowledge engineering is the necessary precursor to development of a useful software prototype or tool. It comprises a body of interview techniques which progress from general discussions of the domain to highly focused sessions. The typical steps in knowledge engineering are:

1. Hold general meetings with one or more experts to obtain an overview of the problem. Collect and study relevant documents regarding the domain.
2. Meet with experts one at a time to discuss the details of their job. Elicit case studies to aid in the process of learning about the domain. Discuss any questions suggested by the collected documents.
3. Observe the expert at work. Ask the expert to explain the steps he is going through to perform the job. Ask which steps are typical and which are special purpose.
4. Structure the knowledge obtained. Discuss the organization of the knowledge with the experts.
5. Once a prototype has been developed, present the software to the experts and get their feedback on its correctness and solicit suggestions for improvements.
6. As tool development progresses, continue to present and discuss the changing versions of the tool to the experts.

### 3.2 Case Based Reasoning

Stottler Henke Associates, Inc. (SHAI) is a pioneer in the development and application of Case-Based Reasoning (CBR). CBR is based on the notion that people often solve problems by remembering the solution to a similar problem and adapting that solution to meet the current circumstances. This is the method we sought to apply to parts obsolescence prediction. For an obsolescence prediction system, the cases are simply other parts, from which inferences and comparisons can be made using CBR. The interactions between the obsolescence factors of a part are very difficult to quantify into usable rules or principles, especially when some of the factors may be unknown. The best way to make these evaluations is by using information from previous cases as a statistical foundation for predictive assessments.

In our investigations of the parts data early in the Phase I effort, we discovered that the use of CBR as originally intended to predict a part's life cycle and obsolescence based on the known obsolescence of a similar part was only marginally possible. This was because many of the fields of the data records were incomplete or inconsistent. This led to a more strongly knowledge base development oriented approach (see Section 3.3). However, we found a number of other significant uses of CBR to aid in the parts obsolescence prediction process. These include identification of a part's predictive family based on the similarity between its description and the family's description, retrieval of alternate equivalent parts, and identification of solutions to similar parts. We also believe our original use for CBR will be possible in tracking and analyzing future weapon systems when stringent data standards are in place. These results are discussed in more detail in Section 5.0.

CBR systems offer enormous benefits compared to standard AI approaches. The knowledge elicitation bottleneck is largely circumvented. Cases can be automatically acquired directly from domain experts. Rules, on the other hand, almost always require the intervention of a knowledge engineer. Instead of having to elicit all of the knowledge required to derive a solution from scratch, only the knowledge required to represent a solution is needed. In simple applications, a case might be represented as a database record of fields. Only the field names and types must be elicited. The data can be entered automatically. So knowledge elicitation is largely avoided with CBR and may be completely automated depending on the type of application and the expert.

Conventional knowledge base technology dictates a single, fixed problem solving methodology. With CBR, each case, in the extreme, can represent a different methodology. Therefore, many problem solving methodologies are represented and, since new cases are continually added automatically, a CBR system's problem solving methodologies can change with time, thus improving its performance and staying up to date and relevant automatically.

There are significant advantages to using CBR in the domain of obsolescence prediction because of the way that knowledge and information are incorporated in a case base. One of the prime difficulties associated with obsolescence prediction arises from the fact that the decision making is carried out by one or a few individuals. The experience base of this individual is likely to be confined to a limited set of domains. This difficulty is exacerbated by high turnover rates, and lack of interaction between geographical and even functional locations. The use of a case-based system which incorporates knowledge from all available resources makes the same level of information available to all users, not only from expert to novice, but also from functional area to functional area and across geographical locations.

The sharing of knowledge that results from universal use of a central case base has many advantages. The adage "knowledge is power" applies in this case, because there are direct benefits which arise from the ability to use the experiential knowledge of others. First, it prevents the otherwise inevitable recurring encounters with the same problems. For example, suppose that it is determined at a depot working on F-14's that a certain microprocessor chip will soon be obsolete in the functional role it currently serves. This knowledge would be very useful at other depots working on other planes that use the same chip for the same function. If the other units are in different locations, it is likely that they will only gain this knowledge much later, or never at all.

There are often communication barriers between functionally different units much like those between geographically separate units, which impair their use of other units' experiential knowledge. If information on microcircuit, electronic and mechanical components is stored in a central corporate knowledge base, it can be accessed immediately to produce unknown relevant cases for any given set of circumstances. This presents an extraordinary opportunity to cross these communication barriers.

### 3.3 Knowledge Based Development

An important aspect of many AI development efforts is the capture of the corporate knowledge of the experts. By eliciting and storing the details of a process, novices can be productive even when the experts are unavailable. For parts obsolescence prediction, we chose to model the evaluation process performed by the Microcircuit Obsolescence Management (MOM) engineers. This involved representing the significant factors affecting prediction, such as the technology, family, number of suppliers, etc. and combining them algorithmically in the same way as the experienced human engineer. We discovered that these factors have different degrees of importance in determining a part's obsolescence evaluation, and that an experienced engineer can perform an evaluation much more quickly and consistently than a new engineer. By automating the prediction process, we achieve greater speed and consistency of evaluations, an audit trail of the decisions made, permitting an explanation of the results, and the capture of valuable knowledge. The details of our solution are given in Sections 7.0 and 8.0.

### 3.4 Object Oriented Programming

Object Oriented Programming (OOP) is a methodology for both representation and programming. Using OOP techniques, one can define different types of objects and specialized program methods that manipulate them. We used OOP for the development of our proof-of-concept prototype. Objects and object hierarchies were used to represent parts data and the weapon system to parts breakdown. Methods which operate on the data objects were used to compute similarity and perform the obsolescence evaluation. Object oriented images were used to develop the user interface of the prototype. In a full-scale version of the DMSMS management system, OOP would be used heavily for data structure representation as well as solutions to parts obsolescence.

### 4.0 PHASE I TASKS

There were nine tasks undertaken in Phase I to achieve the project objectives. These tasks are listed below and described in detail in the subsequent sections.

1. Review Obsolescence Prediction Domain
2. Decide focus of feasibility study
3. Knowledge Elicitation
4. Detailed design of solution
5. Prototype implementation
6. Phase II Design
7. Evaluation of solution
8. End of project briefing and prototype demonstration
9. Final Report

#### 4.1 Review Obsolescence Prediction Domain

The first step in our Phase I investigation was to become thoroughly familiar with the DMSMS problem and identify the organizations and tools involved in DMSMS management. We examined relevant documents such as the Prediction Tool Survey and prepared a list of questions to ask the important players in the domain (see Appendix A). We attended the DMSMS in Jupiter Beach, Florida and learned about DMSMS first-hand. We visited each of the sites involved in DMSMS and found out about their role and the tools they use. We collected documents and data for analysis. We followed up our visits with telephone calls to elicit additional information.

These preliminary investigations of the DMSMS problem allowed us to assess the extent and severity of the problem, the tools currently available, and the Navy's current and future needs in this domain.

#### 4.2 Decide focus of feasibility study

Our mission in Phase I was to improve parts obsolescence prediction techniques and to develop new models of prediction where none currently exist. Our study of the DMSMS problem and our survey of the sites and tools revealed that parts obsolescence for mechanical parts is not a substantial problem and some tools are available to support it (see Section 6.0 for details). For this reason, we decided to focus our feasibility study on microcircuits.

We analyzed the collected information on existing systems and tools and assessed the value of these efforts with respect to the Navy's needs. From this analysis, we further focused on the MOM program and decided to automate the MOM evaluation process and prove the feasibility of this emulation through prototype implementation. This required substantial additional knowledge elicitation and data collection.

#### 4.3 Knowledge Elicitation

We visited the MOM site again to gather the details of the evaluation process and observe the MOM engineers at work. We asked them to show us the evaluation process for half a dozen parts and explain their judgments. We identified the data sources used in the evaluations and collected data for use in our prototype. We were able to establish a definition of requirements for representing and implementing the MOM process. Over subsequent weeks, we continued our discussions with MOM engineers about the details of evaluation process, especially during the our software design work.

#### 4.4 Detailed design of solution

Based on the information collected from MOM engineers and data collection from other sources, we developed a prototype design for parts obsolescence prediction. Additionally, we came up with a concept for an overall DMSMS management system for Phase II implementation. We decided which artificial intelligence techniques could be exploited and which data sources should be used.

#### 4.5 Prototype implementation

We implemented the proof of concept prototype for obsolescence prediction using IntelliCorp's KAPPA-PC object-oriented development tool on a PC 486 with Microsoft Windows. In the process, we learned a great deal more about the prediction process and the realities of the state of the data. Additionally, we implemented a prototype Phase II DMSMS management system to establish the context of the obsolescence prediction component.

#### 4.6 Phase II Design

From our Phase I research and the prototype development efforts, we were able to specify the functionality for a complete Phase II software implementation of a DMSMS management system.

#### 4.7 Evaluation of solution

We evaluated our solution and concluded that automated obsolescence prediction is feasible. Furthermore, if data standards are put in place, more automation is possible and more analysis is possible. We also determined that a proactive DMSMS management system is feasible.

#### 4.8 End of project briefing and prototype demonstration

We prepared briefing charts for an end of project meeting and a demonstration sequence to exhibit the important functionality of the prototype. The purpose of the meeting was to present our Phase I results, elaborate our solution to parts obsolescence prediction and the innovations in our approach, demonstrate our proof-of-concept prototype, and discuss our ideas for future work.

#### 4.9 Final Report

This final report documents the Phase I research activities and results and contains a description of the prototype and the Phase II system specification.

### 5.0 TECHNICAL RESULTS AND PHASE I ACCOMPLISHMENTS

In Phase I, we successfully completed all our stated objectives, and in fact, achieved more than originally anticipated. In this section, we briefly enumerate the technical results. Sections 6.0 through 10.0 describe these results in detail.

1. Mechanical parts obsolescence is not a significant problem.
2. Microcircuit parts obsolescence is largely solution oriented not predictive.
3. Of the predictive systems/programs in existence, MOM is the most comprehensive.
4. Data does not currently support CBR predictive techniques as proposed for Phase I because data is not standardized, there is missing information in data records and some data is unavailable.

5. The MOM predictive process can be automated. We did it in a proof-of-concept prototype. CBR can be used to identify the predictive family so MOM's \$1 Million trends study can be used. A knowledge based obsolescence evaluation can be performed. Where automation breaks down, the system can request specific missing information and complete the evaluation.

6. We identified the structure, standards and required information for collection of new data to allow more of the MOM process to be automated, CBR for obsolescence prediction and even more sophisticated data analysis and trends forecasting

7. Designed and implemented a prototype of a comprehensive DMSMS Management System for proactive management of obsolescence and support for solutions. This system permits integration of relevant databases and can potentially include other parts data such as mechanical, and electronic, as well as microcircuit.

## 6.0 EVALUATION OF EXISTING PREDICTION METHODS/TOOLS

In order to prevent duplication of effort and to better understand the complexities of the DMSMS domain, we identified and evaluated the systems currently in use. The next sections describe the evaluation criteria we began with, the details of the DMSMS process at various sites and the detailed evaluations of tools.

### 6.1 Evaluation Criteria

The following criteria were applied when considering the DMSMS process at various sites and assessing the tools in use.

- Do they predict or are they users of predictions?
- Accuracy of the predictions
- Completeness of databases
  - aliases/cross reference of parts
  - roll up data from parts to systems
- Prediction by family or technology
- Prediction of specific parts' obsolescence rather than % of families
- User friendly
- Accessible
- Cost of prediction in terms of dollars or manpower
- Solutions
  - how good are solutions?
  - do they have access to other's solutions?

## 6.2 Tools/Methods Evaluated

### 6.2.1 Sites Interviewed

#### Ships Parts Control Center (SPCC)

SPCC logistics personnel handle DMS notices for Navy Supply managed parts. The goal is for SPCC to manage only repairable items and for DESC to manage all electronic components. They basically react to DMS notices received; they do not perform any prediction. They coordinate with their users of the DMS parts to determine LOT buy quantities. They access the Weapon Systems File to determine in which systems parts are used; they access DLSC databases to track down more information on the part and related NSNs; they access databases to check the current stock of parts in Navy stores and the current stock at DESC; they also have local databases to track their processing of DMS notices.

#### Defense Electronic Supply Center (DESC)

DESC is the DLA center which handles logistics for electronic commodity classes. They receive DMS notices and coordinate with users, such as SPCC, to perform LOT buys. They only react to DMS notices. They do not perform any predictions. The following six commodity classes, ordered from highest to lowest by number of DMS notices, represent 75% of their DMS cases:

- 5962 - Microcircuits
- 5961 - Semiconductors
- 5960 - Electron Tubes
- 5935 - Connectors, Electrical
- 5905 - Resistors
- 5910 - Capacitors

#### Wright Patterson Air Force Base

Wright Patterson is responsible for establishing the Air Force DMSMS policies/program. They are in the process of collecting information on the current DMS efforts within the Air Force and are also investigating DMS tools and technologies outside the Air Force to consider which to use for the Air Force. Their view is that the Wright Patterson office will provide centralized support to the program offices to make their decision processes related to DMS easier. Currently, the Air Force has not coordinated DMSMS efforts service-wide.

#### NUWC Keyport

The Keyport site supports acoustics systems, towed systems, and combat control systems. They support the DMS management for programs assigned to their site. They

provide proactive assessments of systems before problems arise, processing of DMSMS alerts against system breakdowns, and the generation of solutions to DMSMS problems. At Keyport, they perform assessments of systems using their Electronic Component Technology Analysis (ECTA) process. Their assessments consist of calculating average life-cycle codes for systems. Their NECAD database, described below, is used to support these analyses. They estimated that 99.9% of their DMS cases concern electronic parts.

#### DMS Technology Center (DTC) / NSWC Crane / NAWC Indianapolis

The recently formed DMS Technology Center combines the DMSMS efforts of NSWC Crane and the Health of Naval Aviation (HONA) and Microcircuit Obsolescence Management (MOM) programs from NAWC Indianapolis. The Crane site is similar to the Keyport site in providing direct program support for DMS issues. The MOM program was designated by the Naval Air Systems Command as the lead activity in dealing with microcircuit obsolescence issues. They provide two primary functions to their customers: obsolescence alerts and Microcircuit Technology Assessments (MTAs). The MOM program is described in more detail below.

#### NSWC Philadelphia Carderock Division

The Carderock Division is responsible for handling hull, mechanical, and electrical (HM&E) tech-referrals. Unavailable HM&E parts are documented under an "obsolete without replacement" tech-referral. There are many kinds of tech-referrals with obsolete being only one kind. Non-procurable parts are not classified as DMS by logistics groups unless a DMS notice is received. Unfortunately, the majority of the historical data on these tech-referrals has either been lost or destroyed with only the last 3 years currently available. Approximately 100 of these type of tech-referrals are processed in a quarter. Engineers are assigned the tech-referrals and develop the solutions to these problems.

The following reasons were cited for HM&E obsolete tech-referrals. The demand for these parts is low. Many of the parts are older than 50 years. Only a few parts of each type are on a ship, and the parts have a high reliability and may not have been replaced in 10 to 30 years. Because of the high reliability, the Navy hasn't purchased any of these parts or hasn't purchased enough to keep the manufacturers in business. Additionally, some small businesses have been frustrated with the long delays in obtaining payments from the government and have stopped doing business with the government.

The main problem with these parts is the lack of quality drawings for these parts. In many cases, the drawings of the parts were not purchased; so the exact specifications are not known. Most HM&E parts are considered commercially available so drawings are usually not required as frequently as they are for electronic parts. If a drawing is available, many times the quality of the drawing is poor because of the age of the drawing, because the microfiche of the drawing was poorly done, or because the drawing has been copied too many times. If an acceptable drawing is available, the part can generally be manufactured. Much time is spent finding piece parts to fix the parts or to find suitable replacements.

## Other Sites Handling Mechanical Parts

Many other sites which handle mechanical parts were interviewed. These sites all indicated that the obsolescence problem for mechanical parts was a minor problem. The sites and organizations interviewed included:

- Engineering Branch at ASO
- ASO personnel handling the FA/18 Program
- FA/18 Program - McDonnell Douglas in St. Louis
- P3 Program
- F14 and EA60 Programs in Norfolk
- F16 Program in North Island
- DLA including DGSC, DISC, and DCSC

### 6.2.2 Tools/Methods

#### TACTech

TACTech's system provides information to aid the management of microcircuit and discrete part obsolescence. The system provides a life cycle code for each part. The code, a number from 1 to 5, indicates the part's current position in the ten year technological life cycle. The system is also capable of producing an off-line Product Analysis report for the user's parts list.

Two functions of this system are most utilized by users whom we interviewed. The first function is the identification of detailed part information from part numbers. The TACTech system only contains vendor part numbers and military numbers. It does not accept NSNs or SCDs. The system does provide cross reference information between the military numbers and vendor part numbers to aid the identification of equivalent parts, but the system only contains military parts, either standard military parts or parts tested to MIL-STD-883. In fact, some users rely on the fact that if a part is in TACTech then it is of military quality. The second popular feature of TACTech is the life cycle code. Many users utilize these codes to calculate the obsolescence of their systems by averaging the codes of the parts in the system. Because some parts are not in TACTech, these system averages do not include all the parts in a given system. TACTech's Product Analysis report contains the following sections:

- System Life Cycle Matrix which summarizes the number of parts in each life cycle stage.
- Sourcing Depth By Product Type which details the number of manufacturers of each part and the number of parts from each manufacturer.
- Single Source/No Available Source Summary which lists parts with zero or one source.

- Detailed Parts List Breakdown which identifies potential alternative parts and sources and also possible sourcing issues.
- Parts Excluded From Analysis which contains parts not in TACTech's database.
- Potential Sourcing Issues which summarizes all potential sourcing issues with the reason for the problem.

Although these reports contain much detailed information, none of the users we interviewed during our Phase I effort mentioned utilizing these reports. One drawback of these reports is that much of the information is valuable the first time the report is run, but in future reports the additions and changes from the previous report are the most important information. TACTech's system is available either via a remote connection to their main computer using a modem or installed directly on customer's computers.

**PROS:** life cycle code of parts; cross reference of military numbers and vendor part numbers; processing of alerts against parts list.

**CONS:** missing parts - compromises overall life cycle estimates; life cycle code only indicates how old the technology is, not when it will be obsolete; text-based screens - not very user-friendly; only one-level of breakdown - parts list to parts; only solution support is for alternative parts; no visibility to other users with the same problems.

#### Government Industry Data Exchange Program (GIDEP)

GIDEP is chartered to provide for the full exchange of information between industry and government organizations. GIDEP provides electronic access to the following types of data: engineering data, metrology data, product information, failure experience data, reliability/maintainability data, and urgent data requests. The production information includes DMSMS Notices. Currently, GIDEP is enhancing the DMSMS Notice processing to create the DMSMS Database.

GIDEP currently supports document retrieval for DMSMS Notices. The following fields are available for document retrieval: document number (a GIDEP assigned number), document date, cage code of the manufacturer, participant code (a GIDEP assigned code, e.g. CE9 = TI), a document designator (identifies the type of data: engineering, metrology, etc.), a microfiche locator, and the title of the document. The current system can only search for documents based on these fields. For example, the system cannot electronically search for specific vendor part numbers. The system is suited for visual review of the DMSMS Notifications documents.

The development of the DMSMS Database is presently underway. This effort is split into two phases. The first phase converts the DMSMS notification processing to a relational database. Much of the information currently available only by visually reviewing

the documents, such as vendor part numbers, will be available in fields of the relational database. With this conversion, all of the advantages of relational database technology will also be available to users. This phase also augments the data in GIDEP for each DMSMS notice to include the ICP for the part, the address and phone number of the ICP, the routing identification code (RIC) for the part, the manufacturer's point of contact with address and phone number, and a 35 character field to record the solution or status. The second phase implements a second database to provide a means for government ICPs and managing activities to communicate their DMSMS current and projected future demands. While any user of GIDEP will be allowed to access the information in the first phase database, the information in the second phase database will be restricted to the appropriate users. The system is accessed remotely from personal computers. GIDEP recently released user-friendly software for accessing their system. This user-friendly software has greatly increased the use of the GIDEP system.

**PROS:** one central repository of DMSMS notifications, provides means for logistic personnel and their managing activities to communicate and coordinate responses to DMSMS notices; relational database will provide access to more details and lead to more productive use.

**CONS:** only reactive - database entry only occurs once a DMSMS notice is received; DMSMS database seems tailored for systems supported by logistics groups, cannot upload weapon system breakdown/parts list into system to process DMSMS notices against; one field for solution support for all affected systems seems inadequate.

#### Uwohali's Electronic Component Obsolescence Management (ECOM)

The development of ECOM was started to help manage obsolescence on the Air Force's F-15 AN/APG-63 radar system and today manages parts on the top 15 systems in the F-15. This system is a fairly comprehensive obsolescence management system for this weapon system. The system cross-references OEM/SCD numbers, MILSPEC number, NSNs, vendor part numbers, hybrid part numbers, and generic part numbers for each specific device. Uwohali inputs the weapon system breakdown which they call the Specific Weapon System data. Additionally, the system can provide compliant and equivalent alternate parts. Uwohali performs annual reviews of manufacturers and tracks "high-risk" manufacturers. Periodic updates of the part data are delivered to users.

Projecting future obsolescence is one function of the ECOM system. The prediction is very straightforward. The prediction is performed only for microcircuit and hybrid parts. The projection uses two parameters. One parameter,  $\beta$ , is the point at which all components of a specific technology are no longer available. The second parameter,  $\alpha$ , is the point at which a family of components within the technology starts to become unavailable. Microcircuits are divided into 16 separate families such as logic devices. A straight line projection from  $\alpha$  to  $\beta$  is assumed. This projection is used to predict the number of devices in a system which will be obsolete at a point in the future. For example, if the straight line projection indicates that 30% of the parts within a family are

obsolete in 1996, then their projection will predict that 30% of the parts in that family within a particular system will be obsolete in 1996, but it will not identify which particular parts will be obsolete.

The system runs on IBM-compatible notebook computers in a standalone configuration. Updates to part availability are delivered monthly. The system provides a fairly user-friendly interface including 3-D graphs to depict future part availability.

**PROS:** Part number cross-referencing; supports identification of possible alternative parts.

**CONS:** Standalone configuration precludes sharing solution data; prediction based on a small number of fairly large families and not function specific; dependent on Uwohali for system breakdown input and new part data.

#### US Army Missile Command's MOAT / MOSES

The Microcircuit Obsolescence Analysis Tool (MOAT), developed by BDM Federal, Inc., is a LAN system incorporating TACTech, CAPS, and a MICOM internal configuration system. The system contains information on parts including which systems use the part, which boards use the part, army part numbers, generic part numbers, description, obsolescence status, upgrades, downgrades, manufacturers, and known solution approaches.

The system does not perform predictions. Predictions are manually performed by engineers who base their predictions on the component technology, the life-cycle code from TACTech, and information from vendor contact. The accuracy of these predictions has not been evaluated.

The Microcircuit Obsolescence Solutions Evaluations System (MOSES) is currently under development. This expert system will allow microcircuit engineering analysis to consistently and accurately identify obsolescence solutions. Factors in evaluation solution options include the engineering cost of alternative solutions, the pervasiveness of non available components within the system, and the weapon systems life-cycle status until its planned improvement or end-of-life. This system will document the decision process for each problem and will enforce a standard solution process.

**PROS:** documentation of the solution decision process; standardization of the solution process.

**CONS:** Manual predictions; network does not provide off-site access, MOSES would need to be tailored for other organizations

## NUWC Keyport's Navy Electronic Component Application Database (NECAD)

This database developed for NUWC Keyport contains unit part breakdowns and DMSMS case history information. This database is used to generate Electronic Component Technology Analyses (ECTAs) and to identify which units are affected by DMSMS notices.

Unit breakdowns only exist in NECAD if an ECTA has been performed for the unit. Half of the effort to generate an ECTA is spent obtaining the indented parts list of the unit. Initially, Weapon System File information is extracted for the unit. But in most cases, their units have circuit cards as the lowest repairable item, so the microcircuit part information for these cards was not originally purchased from the OEM and is not contained in the Weapon System File.

The ECTA provides a life-cycle projection of the unit. Known DMSMS alerts are run against the parts breakdown, and the average life-cycle of the parts is calculated. The life-cycle codes used for an ECTA are TACTech's life-cycle codes for the parts. Because TACTech does not contain all parts, the ECTAs cannot include all the parts of the units. The typical cost of performing an ECTA is \$40,000. After an ECTA is performed, new DMSMS alerts can be checked against the unit part breakdown.

NECAD is also used to track DMSMS cases. Cases document the actions and solutions for a DMSMS problem. A case is created for a vendor part affecting a group of very similar units. In addition to the part and affected units, the case also documents the manufacturer and any relevant drawing numbers, and the date the case was created. A log of actions taken, such as important phone conversations and their results, are recorded in the case along with the date of the action. The log also records important information such as cost estimates and LOT buy calculations.

**PROS:** DMSMS case tracking system; ability to check DMS alerts against unit breakdowns.

**CONS:** Dependent on TACTech life cycle codes; alternative part identification depends on other databases.

## MOM Systems

The MOM program provides two major functions for microcircuit and semiconductor parts to their customers: obsolescence alerts and Microcircuit Technology Assessments (MTAs). They utilize four in-house computer-based tools in addition to commercial tools. The in-house tools are the MOM Electronic Bulletin Board Service, the MOM Database, the Technology Trends Forecast (TTF), and the Technology Assessment Database (TAD). The commercial tools which they utilize are IHS's PartsMaster and Haystack, TACTech, and IC Master CD-ROM Plus. The MOM program only provides solutions in the form of alternative parts. Their assessments are delivered to the program managers who must decide on the solution.

The MOM Electronic Bulletin Board Service allows customers to search for microcircuit obsolescence notices and affected systems using queries. The system is accessed remotely using a modem and terminal emulation software. Users may query to find obsolescence notices affecting vendor part numbers, NSNs, military numbers, etc. Standard database query functionality such as wild card searches are also provided. Users may view or download the content of the obsolescence notifications. Additionally, users whose system breakdown has been entered into the MOM database may query to see if any obsolescence notifications have affected their systems.

The MOM database contains comprehensive information on microcircuits and the Weapon System Breakdown information in an Oracle database running on a VAX computer. The information loaded into this database includes data from ASO, SPCC, and DLA. Additionally, information obtained during the MTA process is also loaded into the system. The system is only used internally by the MOM engineers, usually in batch mode, and a user-friendly interface for customers has not been developed.

The TTF is both an internal document and a menu-driven database tool for forecasting microcircuit and discrete family trends. The database tool runs in a standalone mode on an IBM-compatible PC. The tool is utilized in evaluating parts during the development of MTAs. For each of the 1000 technology and function combinations, it contains current life-cycle code, future life-cycle code, preferred function and technology combination for new designs, and an indicator of whether the market demand is increasing or decreasing. Each update of the TTF costs approximately \$1 million.

The TAD is a standalone IBM-compatible PC database used to store and generate the information required to produce MTA reports. The part information for one MTA can be re-used in an MTA for another system containing some of the same parts. Parts not used in previous MTAs must be entered by hand. The TAD is set up to hold a single list of parts for each case/report.

Using the tools mentioned above, the MOM engineers perform an assessment for a list of parts. First, the engineers obtain the following information for each part: SCD number, generic part number, vendor part number, military number, active sources, technology, package style, device description, device function, and technical notes. They start with as much information from the customers as possible. For parts in previous MTAs, they utilize the information already in TAD. For new parts, they use their commercial databases, data books in their library, and phone calls to vendors to identify these required fields. Most of these fields have standard formats which are detailed in their Microcircuit Technology Assessment Procedures and Guidelines (MAPAG) Handbook. After this required information is obtained, the MOM engineers assign an evaluation code to the part. The evaluation codes are I, A, S, N, and O which represent Introductory, Acceptable, Suspect, Near Obsolete, and Obsolete. They follow the guidelines of the MAPAG to assign these codes taking into account the information in the TAD and the forecasting trends from TTF. The MTAs go through an internal review process before they are delivered to the customers.

**PROS:** Comprehensive evaluation process; large amount of part and system breakdown information has been collected; ability to check obsolescence alerts against system breakdowns.

**CONS:** Tools not integrated - some batch, but mainly manual transfer of data between systems; MTAs are only performed on request and are not automatically updated as parts information is updated; assessments are somewhat subjective in gray areas because of differences between engineers.

### HM&E Equipment Data Research System (HEDRS)

The HEDRS system is extensively used by the NSWC Philadelphia Carderock Division to solve obsolete tech-referrals for HM&E parts. This system is managed by the Naval Sea Logistics Center. The system is available on one CD-ROM. The system is a compilation of many databases and files and contains four main modules. One of these modules is the DMSMS Equipment Processing Module. The Engineering Support Code (ESC) field is contained within one of these databases. The value of this field is one of twelve values indicating the ability to obtain the part. Input for this field is obtained from a manufacturer survey to determine if they still can manufacture and support the parts. The information in this system is for equipment level parts such as pumps and motors. Only equipment with an assigned APL is in the system. Much time was spent standardizing the information in this database so that information on similar parts could be effectively retrieved and processed by a computer. Other modules of the HEDRS system may be used to find parts with similar characteristics as a means to identify alternate parts or sources. The User's Manual for this system states that "over half of the approximately 200,000 equipment installed in the Active Fleet have a population of five or less."

### Ships' Maintenance and Material Management (3-M) System

This system contains preventive and corrective maintenance performed and the parts which were required and replaced during the maintenance. The system is maintained by the Naval Sea Logistics Center and runs on the same computer as the Weapons System File. Data is available back to 1972, but only five years are available on-line. The data in the system can be used to calculate failure rates, demand for parts, and MTBF, and tools exist to help obtain these calculations. The information in this system is available to on-line users and also available to non-users in hard-copy reports.

### Equipment Health Model

This Logistics Macro System Health Model was originally developed by Research Analysis Corporation (RAC). The model is based on seven factors which work separately and in combination to calculate a health prediction for a system. The system has been used by the Port Hueneme Division of NSWC. So far the system has only been used on microcircuits, but it has the capability to be used on HM&E data as well. Sources of data

for this system include the Weapons System File, The Ship's 3M System, IHS, and logistics databases. The systems run on an IBM-compatible computer.

### 6.3 Assessment of the Navy's DMSMS Problem and Conclusions

Based on our evaluations, we are able to conclude that DMSMS is not a significant problem for mechanical parts. Further, most DMSMS systems are reactive, not predictive. Of the predictive systems available, MOM appears to be the most comprehensive in terms of the factors considered for obsolescence prediction, use of extensive life cycle information, availability of a large amount of part and system breakdown information, and completeness of data. For this reason, the focus of the remainder of the Phase I effort was on improving and automating the MOM prediction process.

## 7.0 SOLUTION: AUTOMATED OBSOLESCENCE PREDICTION AND PROACTIVE DMSMS MANAGEMENT

### 7.1 Description of our Solution

While the primary objective of our Phase I effort was obsolescence prediction, we learned considerable information about the DMSMS process, the Navy's needs, and future requirements of the program. From this knowledge, we were also able to design a solution for comprehensive, proactive DMSMS management, of which prediction is an integral part. Both these aspects of our solution are described in the sections below.

#### 7.1.1 Automated Obsolescence Prediction

To automate the MOM prediction process, we must replicate the steps MOM engineers carry out wherever possible and provide guidance and support for those functions requiring human involvement, such as research into weapon system to parts breakdown or telephone calls to suppliers. The data for the MOM process is derived from numerous sources including commercial parts databases and a technology trends forecast database compiled every two years for 1000 different families of parts.

When tasked to evaluate obsolescence issues for a weapon system, MOM engineers identify the constituent parts either from existing databases or through investigations in manuals and drawings, determine the family of the part, examine the trends data for that family, and along with nine other evaluation criteria, produce an evaluation code for each part: [A] for acceptable, [S] for suspect, [N] for near obsolete, and [O] for obsolete.

Because parts do not have standardized descriptions, the important process of matching the part with a particular family is very challenging. Our approach is to apply CBR techniques to process the text description of the part and match it to the text description of the family. The only other data field that has proved relevant and is usually available is the technology, which is used to assist this process.

Once the family of the part is identified, the corresponding technology trends forecast may be obtained in a straightforward manner from the trends database. This is one of the most important factors in the overall evaluation of the part's obsolescence. We have developed an expert system to aid in the assessment of the remaining factors and in weighting the factors appropriately to produce an overall evaluation code for the part.

Unlike current DMSMS prediction, our prediction is proactive as well as reactive. These capabilities are described below.

#### Proactive Capabilities

- Program managers are automatically informed when an evaluation code for a part in their weapon system changes.
- System identifies all weapon systems affected by a bad part or DMS notice.
- System identifies critical parts so the operator can prioritize tasks wisely. For example, a critical part might be one which is [S]uspect but almost [N]ear Obsolete. If its number of suppliers were to drop from three to two, its category would change. The operator could then check on those suppliers more frequently than usual.
- System produces action items for the operator to perform that are relevant only to his system.
- Particular weapon systems or parts may be run through the system periodically.

#### Reactive Capabilities

- Users may input a weapon system or parts list and get an evaluation.

#### 7.1.2 DMSMS Management System (DMS3)

The Navy-wide DMSMS management system will address the proactive management of DMSMS and allow coordination of solutions within the Navy. The system will not replicate existing functionality available elsewhere. GIDEP, for example, will be integrated with the DMSMS management system. GIDEP will be the DoD database for DMSMS notifications. GIDEP will also provide for the coordination of logistic organization resolutions to DMSMS notifications. These GIDEP functions only provide for coordination of the reactive management of DMSMS.

Many different categories of users of the Navy-wide system will exist. Weapon system managers, one of the most important users, will use the prediction system to assess the components in their weapon systems and formulate strategies and plans to manage the problem before they receive DMSMS notifications. During design and production, parts lists of proposed systems will be run through the system to screen for obsolescence. Logistics and supply personnel will run analyses on the data in the system to determine trends. Engineers will use the system to review solutions to similar problems, determine solutions to new problems, and to document and track their solutions. Experts on parts and prediction will monitor and maintain the system and the information required by the system to perform accurate predictions. Database functions will be provided to view parts across technology, package style, supplier, etc.

The advantages of the comprehensive DMSMS management system we describe are that the automated prediction process results in faster DMSMS processing and allows engineers to deal with the hard problems and prioritize their tasks. It is proactive so that obsolescence issues are identified earlier. It provides guidance through the solution process and coordination of solution efforts. It may be straightforwardly expanded to include other types of parts (resistors, capacitors, mechanical) and it is owned and controlled by the Navy.

Our Phase II Design includes the following major functionality:

- Parts list research functions. Users need the capability to research the components in their parts lists to identify the actual part numbers and alternative part numbers. Users will not always start with manufacturer part numbers. They may have an NSN, an SCD Number, or a MIL-SPEC number, and they may not be aware which of these they have. These functions will help them identify which representation they have. This information would be shared between Navy functions so that the results may be shared. For example, one SCD may be used on multiple systems, and once it is researched for one system, the results of the research are available to all other systems.
- Weapon System to parts breakdown. This capability allows the users to enter the complete breakdown of systems to units/assemblies to parts. This information is required to perform system/unit assessments and to process DMSMS notifications.
- Part DMSMS predictions. A prediction algorithm which **automatically** gives each part a DMSMS grade. This function was the primary focus of our Phase I prototyping efforts.

- Unit/System DMSMS assessments. These assessments present the DMSMS grades for the parts within the unit or system. These reports would be used by weapon system managers to proactively manage DMSMS by prioritizing redesign efforts/budgets. The up-to-date assessments need to be available on-line, and managers of the systems should be provided with notifications when the assessment changes.
- DMSMS notification processing against units/systems. With the weapon system breakdowns available, DMSMS notifications downloaded from GIDEP can be checked against the breakdowns so that the affected systems can be identified and the appropriate system managers notified. If managers are proactively utilizing the unit/system assessments, they should not be surprised by these notifications if the part predictions are accurate. Thus, they will be able to more accurately respond to requests from logistics personnel on LOT buy queries.
- Coordination and tracking of solutions. Because the weapon system breakdown for all systems will be available in the system, multiple systems affected by the same parts can be identified, and their solutions shared if appropriate (solutions for one system may not be appropriate for other systems). Additionally, solutions from other systems and solutions to similar parts problems from the past will be available for review (using case based reasoning techniques) in solving new problems. This function will also allow the tracking of past cases. Tracking past cases is important where LOT buys were performed to identify any future inventory problems.
- Analysis of data within the system. With all the Navy DMSMS data in the system, previously impossible studies can be performed on the data to identify trends or to perform any number of Navy-wide analyses.
- Solution identification tools. The system will contain utilities to aid the DMSMS solution process. The availability of prior cases and their solutions mentioned above is one such tool. Other tools such as future required inventory calculations based on past use and reliability are also needed. An on-line version of the Navy DMSMS Case Solutions Guide would be included.

## Preliminary Architecture of Phase II DMSMS Management System

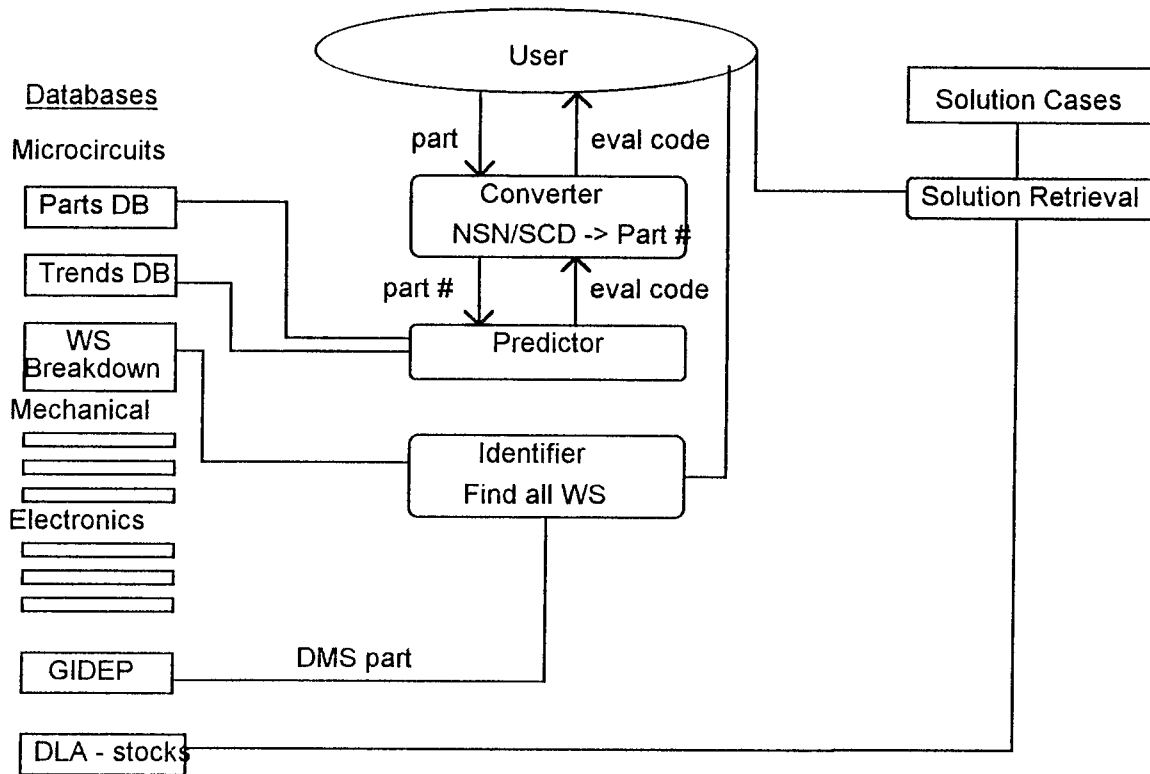

## 7.2 Rationale for the Approach

During Phase I we concentrated on automating the largely manual obsolescence prediction currently performed by the MOM program. Our reasons for concentrating on automating the MOM prediction process are:

- Commercial prediction systems such as TACTech AIM and Uwohali's ECOM do not cover all parts. If a part is not in the system, no prediction is available. It is important for the prediction process to be under the Navy's control so that new parts may be added to the system as needed by the Navy. Program managers want to know the status of **all** the parts in their systems; 80% or 90% of the parts is not enough.
- The life cycle code provided in systems such as TACTech simply reveals how old the technology is, not when the part will be obsolete.
- The MOM program is the only program in the Navy which performs its own predictions. Other organizations utilize prediction results from other prediction systems to perform unit or system prediction, but they do not perform the actual prediction for parts themselves.
- The MOM prediction process is comprehensive and does not concentrate solely on the technology family life cycles for the prediction. Additionally, MOM utilizes the function and complexity, whether the part is military qualified, the device package style, the number of sources, the reliability, the future market demand, emerging technologies, and preferred new products.

Despite the capabilities offered by MOM, the process is largely manual, performed by engineers with considerable experience in the microcircuits domain. By automating the MOM process, novice users can perform at the same level of competence as senior engineers. In fact, a parts obsolescence engineer may not be required for most of the evaluations. His time is better spent focusing on the more difficult problems requiring parts research. Automation of the process permits recording of an audit trail of the evaluation process and produces more consistent evaluations. Results of evaluations can be automatically promulgated to relevant users for increased proactivity. Finally, if the Navy hopes to address its obsolescence issues in a consolidated manner, the MOM program in its current configuration would not have the manpower to process all the evaluation requests. Automation is clearly called for.

## 7.3 Innovations and Intelligent Features

Our solution for obsolescence prediction and DMSMS management is innovative and intelligent. These features are listed in the following two sections.

### 7.3.1 Innovations

Innovation #1: Applying CBR to the Domain of Obsolescence Prediction. CBR techniques have not widely been applied explicitly to this domain.

Innovation #2: Capturing the Solution Process. In Phase II we will be attempting to capture, for later presentation, the process of developing a solution, as well as the solution itself. We will be generating information which will be useful in performing retrieval and for providing explanations to users who are trying to understand the solution.

Innovation #3: Knowledge Engineering Tools. Phase II will develop procedures for carrying out CBR knowledge engineering, along with tools for supporting system developers in the knowledge-engineering task. Knowledge engineering required to construct an expert system entails considerable effort. CBR is a prime candidate for system-aided knowledge elicitation because of the simple nature of the development process. We are not trying to model a world. We merely must find out which analogue cases are relevant, and why, and when to consult them. By a systematic "unpacking" of the rationale behind problem solution, CBR allows the system developer to encode expert knowledge reliably and efficiently. The next step is to provide the developer with automated support. Because there are very detailed records of existing components, tools that accelerate the transfer of information from files to the case base will be of great use.

Innovation #4: Learning. By providing a feedback mechanism, the system will "learn" from its mistakes and actually improve the accuracy of predictive assessments over time. This innovation ties CBR with the work being done in classic machine learning.

Innovation #5: Augmented Retrieval. CBR researchers have developed a number of retrieval methods, and retrieval is a major issue in the construction of a usable system. It is time to provide users with support in managing the retrieval options, by allowing several options to be run simultaneously and by providing guidance about which options to select, as a function of the task parameters and the data base characteristics.

Innovation #6: Rapid Retrieval. We have developed generic definitions of similarity which allow very rapid retrieval of cases from very large case bases. In Phase II, if these definitions are not applicable to this domain, new, high speed algorithms and their accompanying definitions of similarity may have to be developed.

We believe that these innovations significantly extend previous CBR work and help to ensure the useability of the proposed system.

### 7.3.2 Intelligent Features of the DMS3 Solution

#### Prediction

- Automatic proactive notification to relevant users
- Models the human decision process
- CBR to identify predictive family
- Inherent use of similarity for data field comparisons
- Audit trail of evaluation process
- Ability to learn trends over time
- Explanation of evaluation code is constructed dynamically and shown to user
- Makes use of trends
- System knows when it does not know information and can tailor a request to the user to provide the information (e.g. size or speed needed for family identification)
- Can find all weapon systems containing a part from weapon system to parts breakdown
- Evaluations ripple to other affected systems (do not need to receive DMS notices)
- Evaluations can be performed automatically for parts similar to obsolete part
- Evaluations with dates can be kept for future use in tracking performance and using CBR
- Evaluation for one part may be automatically applied to all equivalent parts
- Ability to evaluate an evaluation

#### Solutions

- Automated Decision Process: Capture and automate the decision process experts use to identify the appropriate solution for an obsolescence problem.
- Similarity: Retrieve and consider the solutions to similar parts.

#### Intelligent Interface

- Questions asked of user only when relevant and necessary.
- Interface self-customizing to user
- Interface accommodates all different kinds of part numbers
- Intelligent navigation of large hierarchies in weapon system to parts breakdown

### 7.4 Importance of the Solution

Because DMSMS issues are a significant problem throughout the DOD and commercial industry as well, an intelligent, automated approach to parts obsolescence prediction and management will have broad applicability and offer tremendous benefits. These benefits include the ability for program managers and their staff to readily obtain reliable obsolescence predictions specific to their systems, proactive notification about parts of concern before they are obsolete, the communication of obsolescence problems

and solutions to all interested parties, consistent evaluations and significant long-term cost savings.

The DMS3 solution is not limited only to Navy microcircuit management. It can be applied generally to other types of parts, other branches of the Armed Services, and even to commercial sectors. If the Navy chooses, it may be able to sell this DMSMS management service to these organizations.

## 7.5 Issues

There are a number of issues which deserve attention when considering development of the full-scale Phase II system. The issues and our suggestions for lessening the impact of these problems are given below:

- Obtaining Weapon Systems Breakdowns. The weapon system to parts breakdown for many systems does not exist. For example, many black boxes were bought without their parts list. Unfortunately, the proposed system cannot address this problem.

*Establish requirements such that any new or redesigned systems are delivered with complete parts lists. Continue to research parts lists as needed for current systems.*

- Data Standardization and Incomplete Data. The data and descriptions for parts are not in a standardized format which could be easily processed by a computer. Also, parts data records may be missing fields of information that would be useful for the DMSMS management process.

*Our Phase I effort has addressed this problem and applied innovative methods to solve this problem. The alternative is a large manual effort. Efforts may also be made to establish data definitions and standards so data for new or redesigned systems will be kept in an appropriate and complete format.*

- Protocol for DMSMS management. Navy sites currently maintain their own databases and manage DMSMS differently from one another, primarily in a reactive manner.

*Use of a Navy-wide proactive DMSMS tool would require programmatic changes in protocol and sharing of data and solutions. This does not necessarily dictate consolidation of databases and loss of site control.*

## 8.0 PROOF OF FEASIBILITY/PROTOTYPE DEVELOPMENT

### 8.1 Purpose of Prototype Development

In the Phase I research endeavor, it was necessary to thoroughly understand the domain of study, develop appropriate solutions, and prove the feasibility of those solutions. One very clear proof of feasibility is the successful development of a working prototype.

The prototype developed as part of our Phase I research effort provided a concrete proof of our design concepts. We were able to prove the feasibility of our knowledge representations, prediction techniques and proactive management capabilities.

In addition, the process of developing the prototype provided important information about the design and use of the complete, Phase II DMSMS management system, including refinement of the prediction algorithms. Design of the prototype served as a first pass at Phase II system design, including the layout of the user interface, organization and implementation of the functionality, and development of the underlying representations. By developing a working automated prediction and management system, we were able to isolate difficult aspects of the implementation, determine performance issues relating to speed, memory requirements and hardware, and identify strengths and weaknesses in our software development tools. All this practical experience guided us in the final design of the Phase II DMS3 and permitted improvements in the efficiency and completeness of representations, algorithms, and tool capabilities.

Another important benefit of the prototype is that it gives the Navy a very visual, concrete understanding of our DMSMS solution. Many of the ideas in our prediction methods are highly technical AI concepts. It is much easier to understand these concepts when they are realized in software. Further, by demonstrating a working prototype of the DMSMS management capabilities, it is very easy to appreciate the proactive nature of the solution and the ease of using the tool. Additionally, the prototype development effort allows us to demonstrate our capabilities as both AI researchers and as programmers. We backed up our ideas with working software and proved that we can implement significant functionality in a relatively short time period.

### 8.2 Description of the Prototype Functionality

The prototype prediction and management system was developed in less than six weeks and encompasses significantly more functionality than originally planned. It was implemented using IntelliCorp's KAPPA-PC development tool on a PC 486 machine with Microsoft Windows. APPENDIX B contains the details of the prototype implementation and screen dumps corresponding to a demonstration sequence.

The DMS3 prototype provides proactive notification of changes in part evaluations to users whose weapon systems contain the parts in question. A profile of the user documents the system or systems the user is concerned with. The changes in the evaluation are readily available in the Important Notices window, present by default in the main viewing window of the prototype. The user may examine these notices in greater detail through a mouse click and see explanations for the change in the part's grade. These parts may be saved for later solution processing.

Evaluations may be initiated by the user or triggered automatically by the system in response to DMS notices or pre-defined evaluation schedules. Evaluations are available in seconds for weapon systems, units, and parts, complete with explanations of the evaluation code calculation.

Evaluations may generate action items for the user to carry out when full automation is not possible. The list of action items is prioritized for the user. Typical actions include carrying out a check of current suppliers for a particular part, verifying a DMS notice by calling the supplier, and verifying the family classification.

The user may examine and navigate the weapon system to parts breakdown graphically. The system, unit and part hierarchy is displayed with the evaluation codes of the parts indicated through color highlighting. Parts, units and systems may be edited through this graphical interface. Other functions are available to create, edit, delete and evaluate weapon systems, units and parts from top-level menus.

The prototype demonstrates proactive capabilities by showing automatic evaluation, changes in the important notices and changes in the action items when typical events occur such as DMS notices, a supplier leaving the marketplace and advancement of the date beyond the DMS notice deadline.

The prototype also allows the user to find equivalent parts using similarity methods, NSN searches and SCD searches. Users can also find alternate part names using similarity in case a part name is unknown and is possibly a typographical error. The prototype accommodates all kinds of part names invisibly to the user.

Other functional components of the prototype include parts engineering which gives the user access to similarity definitions, database utilities, trends analysis and database functions for viewing of the data by manufacturer, technology, etc. In the solutions window, a user can retrieve similar parts and examine their case history and request support for determining the type of solution.

### 8.3 Results of Implementation

The prototype used 35 microcircuit parts data selected by MOM engineers for their representative character. It also used relevant data from IHS, TTF, MTA, TACTech and FedLog for processing by prediction algorithms. The following results were obtained

for the two critical aspects of evaluation, first the family identification, and second the evaluation:

#### Family Identification

Of the 35 parts, our family identification methods could correctly choose the one correct family for 25 parts (71% correct). In the remaining 10 cases we were able to generate a list of possible families for each part which contained the one correct family every time. The reason the one correct family could not be chosen was because critical data was missing. In one case no data was available. In four of the cases, the speed of the microcircuit was not specified; in one the size was missing; in three, other data was missing; in one, the descriptions from IHS, TACTech and SMDs were conflicting.

While these types of problems defy automation, they can be easily resolved by asking the user very specific, very trivial questions, such as "What is the size of part AD664TD-UNI/883B?" The user can then select the appropriate family from the small set of family choices provided.

#### Evaluation Process

Even with minimal knowledge engineering efforts, the majority of our automated evaluations matched MOM evaluations exactly. When matches were not exact, the evaluation codes were only off by one grade, which MOM engineers attribute to the subjective nature of the evaluations (two engineers may produce slightly different evaluations). Further knowledge engineering efforts will clarify the details of the evaluation process and accommodate any inconsistencies in TTF or other data.

### 9.0 FUTURE RESEARCH AND DEVELOPMENT

Future research and development will encompass the activities listed below. Additional detail on a Phase II effort will be provided in the Phase II proposal.

#### Research

- Thoroughly evaluate MOM's evaluation codes
- Study MOM process in greater detail to capture heuristic knowledge of experts
- Study overall DMS process in greater detail to determine needs of users
- Study decision process for solution development
- Study integration issues
  - Identify systems and databases required for integration
  - Define system interface

### Requirements Definition

- Define user model. Identify potential users of system and their characteristics and needs.
- Work closely with users to understand their needs for functionality, user interface, security, synchronization of updates, remote access, etc.
- Decide platform for delivery
- Decide development tools/ interface tools to use for the implementation

### Refinement of Software Design

Included in this Phase I Final Report is a preliminary software design and architecture for DMS3. Because considerable additional research will occur at the beginning of Phase II, this design will have to be updated and potentially expanded in light of new requirements, tool choices and platform choices. The software design process encompasses both definition of software modules and the planning of development tasks.

### Implementation: Phase II DMSMS Management System (DMS3)

The implementation, knowledge engineering and software enhancement activities are closely related, iterative, and may proceed in parallel.

DMS3 will be developed in phases to permit periodic incremental releases of the software to the Navy. This will give the Navy maximal control over the development effort and permit feedback from users to improve the software. Incremental releases facilitate the knowledge engineering activities, described in the section below.

Because implementation of a comprehensive DMSMS management system is a large and complex undertaking, the system will be divided into logical functional components or software modules. The primary functionality of these modules may, for the most part, be developed independently. This gives the Navy the flexibility to coordinate the development schedule to meet its most important needs first. DMS3 modules include obsolescence prediction, solutions, database functions, and user interface. Taking into consideration the Navy's priorities, we will likely focus first on implementation of a full-scale version of the obsolescence prediction techniques proved feasible in Phase I.

### Knowledge Engineering

Knowledge engineering is the process of capturing the domain knowledge of the DMSMS prediction and management experts. This involves working closely over an extended period of time with each of the experts to observe them during their work and analyze their use of DMS3. From these interactions, we can refine our user model and prediction techniques, identify other aspects of DMSMS management that can be automated, and capture important user expertise.

### Software Enhancement

Based on suggestions from users and our observations of DMSMS management, prediction and case solution, we will improve the DMS3 software. These improvements include implementation of new features, along with testing and debugging. An iterative approach to software development results in a better final product because the users of the software are allowed input and adjustments throughout the entire development period.

### Documentation Preparation

DMS3 software will be accompanied by user documentation. This includes a user guide, a tutorial, an installation guide and an on-line help facility. However, because DMS3 is designed to be extremely user friendly, this documentation will be primarily for reference and technology transfer to other potential DMS3 users.

### Installation and Training

Because DMS3 software will be released incrementally, installation of each version and training on its new features will take place throughout the development process.

## 10.0 CONCLUSIONS

In Phase I, we applied our AI expertise to the problem of obsolescence prediction and DMSMS management. We developed an innovative solution to obsolescence prediction by automating the MOM evaluation process. Further, we designed a proactive DMSMS management system which incorporates the prediction techniques and gives users capabilities well beyond any current expectations. The automated prediction process results in faster DMSMS processing and allows engineers to deal with the hard problems and prioritize their tasks. It is proactive so that obsolescence issues are identified earlier. It provides guidance through the solution process and coordination of solution efforts. It may be straightforwardly expanded to include other types of parts, and it is owned and controlled by the Navy.

Through implementation of both of these solutions in a prototype, we proved the feasibility of our methods beyond a doubt. This effort laid the groundwork for the successful implementation of the fully functional DMSMS Management System in Phase II.

## APPENDIX A INITIAL KNOWLEDGE ENGINEERING QUESTIONS

Following is the list of questions used in early interviews with specialists in the DMSMS field. The answers to these questions provided useful background on the problem and a springboard for further knowledge engineering.

1. What is the function of your site?
2. What area of DMSMS are you involved in? What parts do you work with?
3. Is historical data on obsolete parts available? What form is it in? Can we use it in our prototype?
4. What information is kept for the parts?
5. What information is kept for the DMS case?
6. How many parts/systems do you track per month or year?
7. How many DMS cases do you handle per month or year?
8. What is the process you currently use to deal with DMSMS?
9. Could you step us through several examples?
10. What tools or algorithms do you currently use for parts, DMS, etc?
11. What are the limitations of these tools?
12. What computer hardware do you use (PCs, Macintoshes, workstations)?
13. Do you predict obsolescence before it occurs (proactive vs. reactive)? If so, how (tools, experience, guidelines, rules-of-thumb, etc.)? How accurate is the prediction?
14. What are the communication requirements among sites dealing with DMS? How frequent is communication among sites?
15. What are the integration requirements with existing systems or among databases at various sites?
16. What do you need in a DMSMS system? What are your requirements for functionality, accessibility, and user interface?
17. Could you recommend anyone else we should talk to?

## APPENDIX B      DETAILS OF THE PHASE I PROTOTYPE

### B.1    Details of the Prototype Implementation

#### B.1.1    Predictive Family Identification

One step which MOM engineers perform while evaluating parts is the generation of a standardized description. This description aids identifying which of the 1000 TTF family classifications is appropriate for this part. The first step in our prototype development was to evaluate the feasibility of automatically performing this predictive family identification from the available parts data. The MOM engineers utilize primarily two databases, one from IHS and another from TACTech, to perform this identification.

Initially, we used the ESTEEM Case-based Reasoning (CBR) shell, a commercial CBR tool developed by SHAI, to test matching the part descriptions available in commercial databases against the 1000 TTF family descriptions. The Partial Word Match similarity definition was used to compare part descriptions from IHS to the family descriptions. This similarity definition compares the words of the two strings. The part descriptions from TACTech were compared in a similar manner to the family descriptions. The initial results revealed the necessity to use a standardized vocabulary in the descriptions. These results also indicated that the TACTech descriptions contained much more detail than the IHS descriptions, and because of this fact, the TACTech descriptions generated higher similarity scores with the appropriate families.

In the second trial, the descriptions were standardized using a list of synonyms and abbreviations. The vocabulary used in the part descriptions were analyzed and determined to be small enough to standardize. The TTF family descriptions, the IHS descriptions, and the TACTech descriptions were all standardized using a small program. These standardized descriptions were input to ESTEEM and compared using the same similarity definition. The results of this second trial were much improved. Analysis of these results determined that specific words in the descriptions should contain more weight in the similarity score than other words. These "keywords" were identified mainly as the nouns in the description such as RAM, EEPROM, MULTIPLEXER, and DRIVER.

Utilizing these results and the fact that standard class descriptions were available for SMDs, the following two-step process was implemented:

- 1) The category of the part was computed. The TTF family descriptions are divided into the following six categories: Digital, Linear, Interface, Memory, Microprocessor, and Custom. The SMD classes were mapped against these categories. For SMD parts, the category was immediately identified from the SMD class. For non-SMD parts, the keywords in the IHS and TACTech descriptions were compared against a list of keywords for each category. Using CBR and this similarity definition, the most similar category was determined.

Determining the category reduced the number of possible TTF family descriptions by approximately 1/6.

2) Next the family within the category was determined. The following similarity definition was used to identify the family:

Field	Weight	Similarity Definition
Technology	30	1 if exact match 0.5 if same technology family, e.g. TTL and LS-TTL.
Function Description	35	Partial Word Match
Function Description	35	Number of keywords in both descriptions divided by the maximum number of keywords in either description

Each of the two Function Description scores is the maximum of the following comparisons:

- a) The TTF family function description and the IHS description
- b) The TTF family function description and the TACTech description
- c) The TTF family function description and the SMD class description.

The overall similarity score was a weighted sum of the technology similarity score and the two function description similarity scores.

### B.1.2 Assessment Algorithm

The generation of an Evaluation Code depends on many factors. The factors from the TTF family are the current life cycle code, whether the function and technology are acceptable for new designs, and whether the market for this function and technology is increasing or decreasing. The other main factors in the assessment are the number of current manufacturers, the number of manufacturers which have left in the past two years, and a projection of the number of manufacturers in two years.

The following table summarizes the assessment algorithm implemented in the prototype:

Eval Code	Requirements
A (acceptable)	<ul style="list-style-type: none"> <li>- Part is acceptable for new designs</li> <li>- Part has military grade reliability</li> <li>- There have been no DMS notices for this type of part for 2 years</li> <li>- There is at least one current supplier of the part</li> <li>- The life cycle code of the part is less than Mature</li> </ul> <p style="text-align: center;"><b>or</b></p> <p>The life cycle code of the part is less than Saturated <b>and</b> the market for this part is increasing</p>
S (suspect)	<ul style="list-style-type: none"> <li>- Part does not meet acceptable requirements</li> <li>- Part is acceptable for new designs</li> <li>- Part has military grade reliability</li> <li>- The two year projection indicates there will still be at least one supplier.</li> <li>- There is at least one current supplier of the part</li> </ul> <p style="text-align: center;"><b>or</b></p> <ul style="list-style-type: none"> <li>- Part does not meet acceptable requirements</li> <li>- The life cycle code of the part is less than Declining</li> <li>- The two year projection indicates there will still be at least one supplier.</li> <li>- There is at least one current supplier of the part</li> </ul>
N (near obsolete)	<ul style="list-style-type: none"> <li>- Part does not meet acceptable or suspect requirements</li> <li>- There is at least one current supplier of the part</li> </ul>
O (obsolete)	<ul style="list-style-type: none"> <li>- There are no known suppliers of the part.</li> </ul>
U/R (under review)	<ul style="list-style-type: none"> <li>-The unit part does not have any vendor parts specified (i.e the part is unknown)</li> </ul> <p style="text-align: center;"><b>or</b></p> <ul style="list-style-type: none"> <li>-The predictive family of the part is unknown.</li> </ul>

### B.1.3 Major Classes in the Prototype

#### Systems, Units, Unit Parts, and Vendor Parts

The breakdown of a weapon system in the prototype was simplified to be a three level hierarchy. The system is the highest level. It is composed of units which, in turn, are composed of unit parts. Unit parts contain a list of equivalent vendor parts. For example, the unit parts could be named by OEM drawing numbers (SCDs), SMDs, NSNs, or vendor part numbers themselves. The vendor parts listed in a unit part have identical form, fit, and function. Vendor parts are simply the parts which manufacturers build and sell. The vendor parts are named by the part number of their respective manufacturers.

#### Families

Families represent classifications of vendor parts. Two subclasses for families are implemented in the prototype: SMD classes and TTF Families. The SMD classes are the functional groupings of SMDs listed in MIL-BUL-103X. They contain functional descriptions of the SMD. The TTF families contain the information from the MOM TTF database. For each of the 1000 families, the prototype contains the following information: technology, function description, current life-cycle code, future life-cycle code, preferred function and technology combination for new designs, and an indicator of whether the market demand is increasing or decreasing. The information from these two sets of families is used to support the assessment calculations.

#### Equivalent Parts

The Equivalent Parts classes contain lists of form, fit, and function replacement vendor parts or candidates to use as replacements. The prototype contains two subclasses of Equivalent Parts. The SMDs class contains SMD information downloaded from the DESC bulletin board service. Each SMD object identifies its SMD and the vendor parts which conform to the SMD. The SMD parts are considered extremely good candidates for form, fit, and function replacements. The NSNs class contains information extracted from the FEDLOG system. NSNs in FEDLOG normally contain references to SMDs, SCDs, and vendor part numbers. The information in the prototype for NSNs was limited to vendor part numbers. Part numbers in an NSN are not considered as good candidates for replacement parts as SMD part number lists.

#### Vendors / Manufacturers

The Vendor classes contain information on manufacturers including their name, cage code, and address.

## Vendor Parts

The vendor part objects include the vendor part number, the manufacturer, the technology, the description, the IHS description, the IHS technology, the TACTech description, the TACTech technology, the predictive category, the predictive family, notes on parameters, and DMS notice information.

## User Profiles

The User Profile objects define the users of the system. These objects contain the name of the user, the systems of interest to the user, the phone number of the user, the organization of the user, and the last time the user logged in to the system.

## Cases

Cases document the actions and solutions for a DMSMS problem. A case is created for a vendor part affecting a group of very similar units. The case contains the vendor, the vendor part number and the units and systems to be handled together. A log of actions taken, such as important phone conversations and their results, can be recorded in the case along with the date of the action. The case can also record important information such as cost estimates and LOT buy calculations.

## Action Items

These objects contain the actions which the user must perform so that the assessments may be as accurate as possible. The prototype generates action items when it cannot completely assess the part itself. Examples of action items include identifying the predictive families for parts for which the system does not have enough information to perform the identification itself. When the user selects an action item, the system provides the user with all the relevant information which it possesses so that the user's job is as straightforward and painless as possible. In the above example, when the user selects the identify predictive family action item, the prototype presents the user with the most likely predictive family from the information available.

### B.2 Prototype Demonstration Sequence/Screen Dumps

This section contains detailed views of the functionality of the prototype through a typical user session. Section B.2.1 contains a demonstration sequence which highlights the prototype functionality. Screen dumps corresponding in detail to this sequence follow in Section B.2.2.

#### B.2.1 Demonstration Sequence

1. Type PARTS from the C:\SHAI\PARTS directory in DOS. One user's screen will appear and the second user's screen will be iconized.

2. View the Important Notices screen of the first user. Important notices currently displayed show changes in Evaluations since the user was last logged in.

Double Click on the important notices (26LS32/BEAJC) to show the explanations on the Unit Part Evaluation window - both the evaluation explanation and the DMS notice for the manufacturer part.

Close the User Part Evaluation Window.

3. Select the User Profile... option on the File Menu and view information about the user and the weapon system he is interested in.

Click OK to close the User Profile editor.

4. Click on the Weapon System Hierarchy and select System1. Colors indicate part evaluation codes.

View the hiding and showing of parts and units.

Close the hierarchy window.

5. Select the Evaluation icon, select Weapon Systems, and select System 1.

View the summary statistics. \* in front of Unit B - denotes a change since the last login.

Double Click on Unit B to bring up the unit evaluation. View the summary statistics and the \*'s.

Double Click on the part IDT6116SA150TDB to show its evaluation.  
Close the Part Evaluation Window.

Double Click on the part 54F175DMQB to show its evaluation.  
Close the Part Evaluation Window.

Double Click on the part AD664TD-UNI/883B to show its evaluation.  
Close all the evaluation windows.

6. Expand the window of the second user. Note that he has no important notices.

View his Weapon System Hierarchy (select System 2) and parts that overlap those in the first users system (mainly 54LS244DMQB). Most do not overlap.

7. From the demo title bar Events menu, select the DMS Notice... option.

Enter a DMS notice for

part :54LS244DMQB  
manufacturer :TEXAS INSTRUMENTS  
dms date:1-MAY-1995

Note that an important notice appears in each user's screen because they both use this part in their systems.

8. From the top user's window, select the Action Items icon.

Double click on the Verify DMS notice for part 54LS244DMQB and select DMS Notice verified.

Double click on the Check Suppliers for 54LS244DMQB and select Still in Production for each vendor part. Then close the Check Suppliers window.

Double click on the Identify Predictive Family for part AT28MC010-12MMB, select "CMOS 1M EEPROM" as the predictive family and select OK. The part has now been evaluated.

Close the Action Item Window.

Open the Action Item Window for the second user and show that the action item's are gone for him too.

Close the Action Item Window.

9. From the demo title bar Events menu, select the DMS Notice... option.

Enter a DMS notice for

part : SNJ54HC00J  
manufacturer :TEXAS INSTRUMENTS  
dms date:1-FEB-1995

Note that an important notice only appears in the second/bottom user's screen because only his system is affected.

10. In the important notices screen for the bottom user, click once on the SNJ54HC00J line to highlight it.

Select Save on the Important Notices pseudo-menu bar and select To Case. This will cause a Case for this problem to be created. The Solutions Window will be displayed with this new case displayed.

Select the List Other Affected Systems option on the Case Menu. A list of other affected systems will be displayed in a list box on another window.

Double click on the systems to show that the manager with his phone number is displayed. Close the window.

Select Find Similar Cases from the Case Menu. The Similar Cases window will be displayed with 3 similar cases with 3 different solutions.

Close the similar cases window.

Select Edit from the Case Menu and choose Case12. This more fully filled out case is an actual case from Keyport's Necad system.

Close the Solutions Window.

11. From the Events menu, select Change Date.

Select the Enter new date radio button and enter a date of 15-May-1995.  
Close the Change Date window.

From Important Notices screen, note that part IDT6116SA150TDB with one supplier whose DMS Date was 15-May-1995 have changed to eval code O (obsolete) from N (near obsolete).

Bring up Action Items screen from the bottom user, and show that the N part, 54LS244DMQB, which was evaluated 2 months before has been re-evaluated and the suppliers must be checked again.

Change the prioritize to By # Systems Affected.  
Then Change back to By Date.

Close the Action Items window.

12. From the Actions menu, Select the Supplier Leaves option and enter the following into the form:

supplier: MOTOROLA, INC.

date: 1-Jun-95

type of parts: Military parts

Note the Important Notice for changed grades of these parts.

Click on the Action Items of the top user and view the "Verify DMS notices" for Motorola parts. Only the parts whose evaluations changed were listed in the Important Notices.

Close the bottom user's screen.

13. Select Edit from the Weapons System menu and then select System1.

Double-click on Unit B to edit it.

Click on the Edit Unit Details and explain the detailed unit information - there would be more in a Phase II system.

Double-click on IDT71256S100DB part.

Click on Edit Details to show details of part - again more would be provided in a Phase II system.

Click on the Add Equal Parts button, and select each of the CBR, NSN, and Mil equivalent options. The CBR will retrieve more than any, the NSN will retrieve some, and the Mil will retrieve no new equivalents. For each of these select cancel when the equivalents list is displayed.

Double Click on the first mfr part in the list IDT71256S100DB from IDT.  
Close the part and unit editors.

Double click on Unit A to edit it.

Select Add Part and enter 7802301ME, an SMD.

Double Click on the part to edit the part. The equivalent parts listed in the SMD have been added.

Select Edit Details and show that the Military Number has been filled in.

Close the Details and Edit Parts windows.

Select Add Part on the Unit Edit window and enter 01-253-4263, an NSN.

Double Click on the part to edit the part. The equivalent parts listed in the NSN have been added.

Select Edit Details and show that the NSN has been filled in.

Select Add Equal Parts and select Mil equivalents.

One additional part will show. Select the Cancel option.

Close the Edit Parts windows.

Select Add Part on the Unit Edit window and enter PLDC20G10-30WMB, a vendor part number.

Double Click on the part to edit the part.

Close the Edit Parts window.

Select Add Part on the Unit Edit window and enter 8775501R, an invalid number.

Double Click on the part to edit the part and note that no vendor parts are listed.

Close the edit windows.

14. Open the Action Items window for the top user, and show the Identify Part 8775501R action item.

Double Click on the action item, and the part will be researched. This will take about 1 minute. In a Phase II system this would be much faster. The list of possible parts will be displayed. This should have been 8755501R, an SMD.

Close the Part Research and Action Item windows.

15. Select the Parts Engineering icon.  
View the System Action Items and menus.

Select Research Part. This performs the same function which was just demonstrated.

View the Definitions options:

### B.2.2 Screen Dumps

The following screen dumps correspond to the actions performed in the demonstration sequence. Two screens are printed to each page.

**DMS\* Prototype Demonstration**

Events Reset Exit

**DMSMS Management System [DMS\*] - User 1**

File WeaponSystems Units Parts Help

User Name: Jeff Wilson      Organization: NAVAIR      Date: 17-Feb-1995

**Important Notices**

Edit	Save	Delete	Prioritize		
1	16-Feb-1995	UnitID	26LS32/BEAJC	EvalCode: S	

  
 Action Items

  
 Evaluations

  
 Solutions

  
 Weapon Sys Hierarchy

  
 Parts Engineering

  
 DMSMS Management System [DMS\*] - User 2

**DMS\* Prototype Demonstration**

Events Reset Exit

**DMSMS Management System [DMS\*] - User 1**

File WeaponSystems Units Parts Help

User Name: Part Evaluation

Name: 26LS32/BEAJC

Description: BUS/LINE RECEIVER, DIFF

Technology: TTL

Package: DIP

Evaluation Code: S

Explanation: Part is recommended for new designs  
 Current Life Cycle Code of part is GRO-E  
 Part has military/government suppliers  
 Currently, there are 2 manufacturer(s).  
 In 2 years, there are predicted to be 1 manufacturer(s).

**Vendor Parts**

Change	Status	Vendor	Part
*	DMS NOTICE	MOTOROLA	26LS32/BEAJC
	DMS notice received with last buy date of 1-Jun-1995.		
	ACTIVE	PHILIPS	26LS32/BEA

**DMS<sup>3</sup> Prototype Demonstration**

Events   Reset   Exit

**DMSMS Management System (DMS<sup>3</sup>) - User 1**

File   WeaponSystems   Units   Parts   Help

UserProfile...   on   Organization: NAVAIR   Date: 17-Feb-1995

Print...   Important Notices

Exit   Delete   Prioritize

1995   UnitB   261632/BEAJC   EvalCode: S

About DMS<sup>3</sup>...

  
 Action Items

  
 Evaluations

  
 Solutions

  
 Weapon Sys Hierarchy

  
 Parts Engineering

  
 DMSMS Management System (DMS<sup>3</sup>) - User 2

**DMS<sup>3</sup> Prototype Demonstration**

Events   Reset   Exit

**DMSMS Management System (DMS<sup>3</sup>) - User 1**

File   WeaponSystems   Units   Parts   Help

User Name: Jeff Wilson   Organization: NAVAIR   Date: 17-Feb-1995

**Important Notices**

Edit   Save   Delete   Remove

1	16-Feb-1995	
---	-------------	--

**Update Profile:**

Name:

Organization:

Weapon System:  ▼

Phone Number:

  
 Action Items

  
 Parts Engineering

  
 DMSMS Management System (DMS<sup>3</sup>) - User 2

**DMS<sup>3</sup> Prototype Demonstration**

Events    Reset    Exit

**DMSMS Management System (DMS<sup>3</sup>) - User 1**

File    WeaponSystems    Units    Parts    Help

User Name: Jeff Wilson                      Organization: NAVAIR                      Date: 17-Feb-1995

**Important Notices**

Edit	Save	Delete	Priorize
1	16-Feb-1995	UnitB	26LS32/BEAJC                      EvalCode: S

**Weapon System Hierarchy**

Choose a system to display:



Action Items



Parts Engineering



DMSMS  
Management  
System (DMS<sup>3</sup>) -  
User 2

**System Hierarchy: System1**

Exit

**Key to Evaluation Colors:**  
Green = Acceptable  
Blue = Suspect  
Yellow = Near Obsolete  
Black = Obsolete  
 Normal = Under Review

System1

- UnitA
  - BG20ZAK/BD3H
  - 1595/BCAJC
  - XC2018-33PGB4B
  - HD20F020-20/E
  - 26LS32/BEAJC
  - 54F175DMQB
- UnitB
  - AD664TD-NM1/BD3H
  - IDT71256S100DB
  - IDT6116SA150TDB
  - 54LS244DMQB
- UnitC
  - AT28MC010-12MMB
  - 54LS100

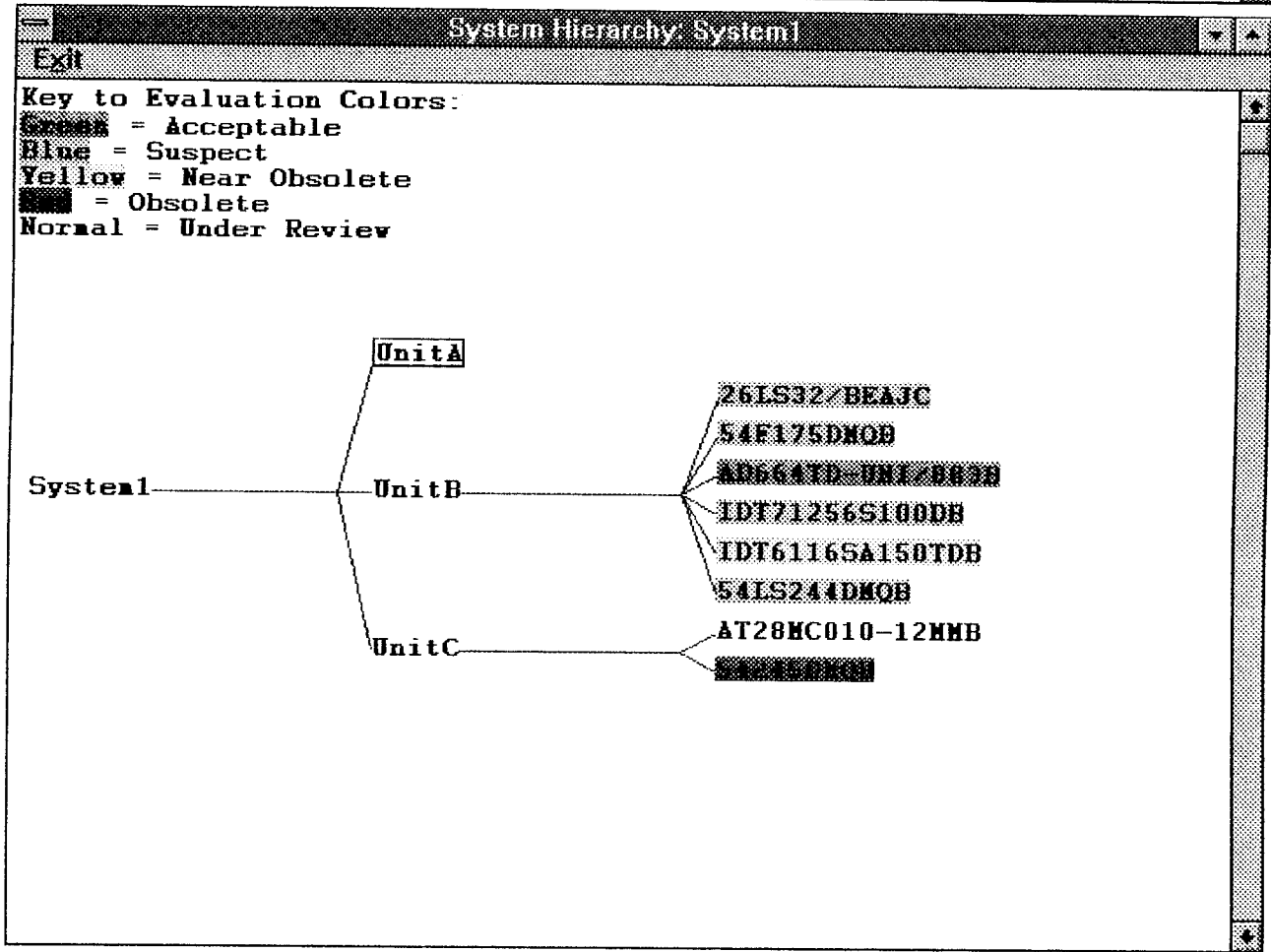
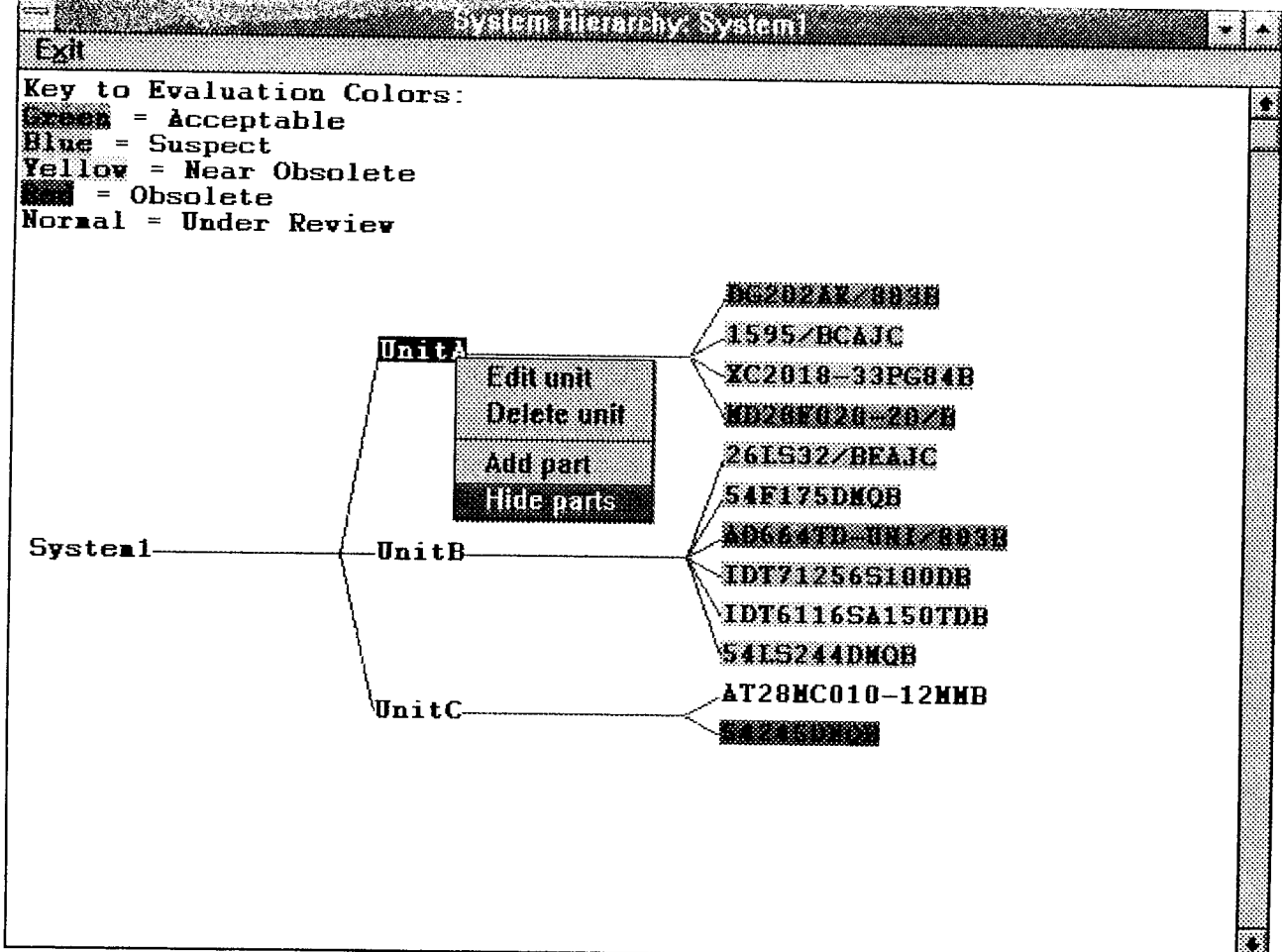

**DMS<sup>3</sup> Prototype Demonstration**

Events Reset Exit

**DMSMS Management System [DMS<sup>3</sup>] - User 1**

File WeaponSystems Units Parts Help

User Name: Jeff Wilson      Organization: NAVAIR      Date: 17-Feb-1995

**Important Notices**

Edit	Save	Delete	Prioritize	
1	16-Feb-1995	UnitB	26L632/BEAJC	EvalCode: S

**Weapon System**

Unit

Part

  
 Action Items

  
 Evaluations

  
 Solutions

  
 Weapon Sys Hierarchy

  
 Parts Engineering

  
 DMSMS  
 Management  
 System [DMS<sup>3</sup>]-  
 User 2

**DMS<sup>3</sup> Prototype Demonstration**

Events Reset Exit

**DMSMS Management System [DMS<sup>3</sup>] - User 1**

File WeaponSystems Units Parts Help

User Name: Jeff Wilson      Organization: NAVAIR      Date: 17-Feb-1995

**Important Notices**

Edit	Save	Delete	Prioritize	
1	16-Feb-1995	UnitB	26L632/BEAJC	EvalCode: S

**Evaluate Entry**

Enter name of system to evaluate:

  
 Action Items

  
 ts Engineering

  
 DMSMS  
 Management  
 System [DMS<sup>3</sup>]-  
 User 2



DMS\* Prototype Demonstration

Events    Reset    Exit

---

System Evaluation    er 1

---

Unit Evaluation

---

Part Evaluation

Name: IDT6116SA150TDB

Description:    STATIC RAM  
 Technology:    CMOS  
 Package:        DIP

Evaluation Code:    N  
 Explanation:    Part is NOT recommended for new designs  
                   Current Life Cycle Code of part is OBS  
                   Currently, there are 1 manufacturer(s).  
                   In 2 more years, there are predicted to be 0 manufacture

---

Vendor Parts

Change	Status	Vendor	Part
*	DMS NOTICE	IDT	IDT6116SA150TDB
DMS notice received with last buy date of 1-May-1995.			

DMS\* Prototype Demonstration

Events    Reset    Exit

---

System Evaluation    er 1

---

Unit Evaluation

---

Part Evaluation

Name: 54F175DMQB

Description:    D-TYPE FLIP-FLOP, QUADRUPLE  
 Technology:    ASTTL  
 Package:        DIP

Evaluation Code:    S  
 Explanation:    Part is NOT recommended for new designs  
                   Current Life Cycle Code of part is GRO  
                   Currently, there are 3 manufacturer(s).

---

Vendor Parts

Change	Status	Vendor	Part
	ACTIVE	FAIRCHILD	54F175DMQB
	ACTIVE	TI	54F175DMQB
	ACTIVE	NATIONAL	54F175DMQB

**DMS\* Prototype Demonstration**

Events Reset Exit

**System Evaluation**      er 1

**Unit Evaluation**

**Part Evaluation**

Name: AD664TD-UNI/883B

Description: D/A CONVERTER, 12-BIT, QUAD  
 Technology: BIPOLAR  
 Package: DIP

Evaluation Code: A  
 Explanation: Part is recommended for new designs  
 Current Life Cycle Code of part is MAT-E  
 Part has military/government suppliers  
 No manufacturers have left within the past 2 years  
 Market for this part is increasing

**Vendor Parts**

Change	Status	Vendor	Part
	ACTIVE	ANALOG C1	AD664TD-UNI/883B

**DMS\* Prototype Demonstration**

Events Reset Exit





**DMSMS Management System (DMS\*) - User 1**

File WeaponSystems Units Parts Help

User Name: Jeff Wilson      Organization: NAVAIR      Date: 17-Feb-1995

**Important Notices**

Edit	Save	Delete	Prioritize	
1	16-Feb-1995	UnitB	26LS32/BEAIC	EvalCode: S

 Action Items     
  Evaluations     
  Solutions     
  Weapon Sys Hierarchy     
  Parts Engineering

---





**DMSMS Management System (DMS\*) - User 2**

File WeaponSystems Units Parts Help

User Name: Dave Jones      Organization: NAVSEA      Date: 17-Feb-1995

**Important Notices**

Edit	Save	Delete	Prioritize	
------	------	--------	------------	--

 Action Items     
  Evaluations     
  Solutions     
  Weapon Sys Hierarchy     
  Parts Engineering

**DMS<sup>3</sup> Prototype Demonstration**

Events    Reset    Exit

**DMSMS Management System (DMS<sup>3</sup>) - User 1**

File    WeaponSystems    Units    Parts    Help

User Name: Jeff Wilson      Organization: NAVAIR      Date: 17-Feb-1995

**Important Notices**

Edit    Save    Delete    Prioritize

1	16-Feb-1995	UnitB	26LS32/BEAJC	EvalCode: S
---	-------------	-------	--------------	-------------

**Weapon System Hierarchy**

Choose a system to display:

Action Items      Parts Engineering

File    Weapon      te: 17-Feb-1995

User Name: Dave

**Important Notices**

Edit    Save    Delete    Prioritize

**System Hierarchy: System2**

Exit

**Key to Evaluation Colors:**

= Acceptable

= Suspect

= Near Obsolete

= Obsolete

= Under Review

```

graph LR
    System2 --- Unit1
    System2 --- Unit2
    System2 --- Unit3
    System2 --- Unit4
    Unit3 --- S4AC373JNQB
    Unit3 --- A1D2DR PG84B
    Unit3 --- S4LS244DNQB
    Unit3 --- EM1DSE-1 2/883
    Unit3 --- REF01A2/003C
    Unit3 --- SNJ54HC00J
  
```

DMS Prototype Demonstration

Events Reset Exit

DMS Notice... DMSMS Management System (DMS\*) - User 1

Supplier Leaves... Units Parts Help

Change Date... Organization: NAVAIR Date: 17-Feb-1995

Important Notices

Edit	Save	Delete	Prioritize
1	16-Feb-1995	UnitB	26LS32/BERJC EvalCode: S

Action Items Evaluations Solutions Weapon Sys Hierarchy Parts Engineering

DMSMS Management System (DMS\*) - User 2

File WeaponSystems Units Parts Help

User Name: Dave Jones Organization: NAVSEA Date: 17-Feb-1995

Important Notices

Edit	Save	Delete	Prioritize
------	------	--------	------------

Action Items Evaluations Solutions Weapon Sys Hierarchy Parts Engineering

DMS\* Prototype Demonstration

Events Reset Exit

DMSMS Management System (DMS\*) - User 1

File WeaponSystems Units Parts Help

User Name: Jeff Wilson Organization: NAVAIR Date: 17-Feb-1995

Important Notices

Edit	Save	Delete	Prioritize
1	16-Feb-1995	UnitB	26LS32/BERJC EvalCode: S

DMS Notice Form:

Part Number: 54LS244DMQB 54LS244DMQB

Manufacturer: TEXAS INSTRUME

Date: 1-MAY-1995

OK Cancel Reset

Action Items Evaluations Solutions Weapon Sys Hierarchy Parts Engineering

User Name: Dave Jones Organization: NAVSEA Date: 17-Feb-1995

Action Items Evaluations Solutions Weapon Sys Hierarchy Parts Engineering

**DMS\* Prototype Demonstration**

Events Reset Exit





**DMSMS Management System (DMS\*) - User 1**

File WeaponSystems Units Parts Help

User Name: Jeff Wilson      Organization: NAVAIR      Date: 17-Feb-1995

**Important Notices**

	Edit	Save	Delete	Prioritize		
1					17-Feb-1995	UnitB      54LS244DMQB      EvalCode: N
2					16-Feb-1995	UnitB      26LS32/BEAJC      EvalCode: S

 Action Items     
  Evaluations     
  Solutions     
  Weapon Sys Hierarchy     
  Parts Engineering





**DMSMS Management System (DMS\*) - User 2**

File WeaponSystems Units Parts Help

User Name: Dave Jones      Organization: NAVSEA      Date: 17-Feb-1995

**Important Notices**

	Edit	Save	Delete	Prioritize		
1					17-Feb-1995	Unit3      54LS244DMQB      EvalCode: N

 Action Items     
  Evaluations     
  Solutions     
  Weapon Sys Hierarchy     
  Parts Engineering

**DMS\* Prototype Demonstration**

Events Reset Exit

**DMSMS Management System (DMS\*) - User 1**

**Action Items**





	New	Edit	Delete	Prioritize		
1					17-Feb-1995	Check suppliers for part 54LS244DMQB of unit UnitB.
2					17-Feb-1995	Verify DMS notice for: 1E3AS 1 54LS244DMQB on 17-Feb-1995.
3					16-Feb-1995	Identify predictive family for part AT28MC010-12MMB of unit U

**DMSMS Management System (DMS\*) - User 1**

User Name: Dave Jones      Organization: NAVSEA      Date: 17-Feb-1995

**Important Notices**

	Edit	Save	Delete	Prioritize		
1					17-Feb-1995	Unit3      54LS244DMQB      EvalCode: N

 Action Items     
  Evaluations     
  Solutions     
  Weapon Sys Hierarchy     
  Parts Engineering

**DMS\* Prototype Demonstration**

Events   Reset   Exit

**DMSMS Management System (DMS\*) - User 1**

**Action Items**

New   Edit   Delete   Prioritize



1	17-Feb-1995	Call TEXAS INSTRUMENTS INC at (695) 892-4311 to verify DMS date 1-May-1995 for part 54LS244DMQB.	Unit UnitB.
2	17-Feb-1995		3 on 1-May-1995.
3	16-Feb-1995		MC010-12MMB of unit U

Cancel   Change DMS date   DMS notice verified

User Name: Dave Jones   Organization: NAVSEA   Date: 17-Feb-1995

**Important Notices**

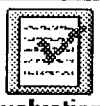
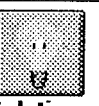
Edit	Save	Delete	Prioritize			
1	17-Feb-1995	Unit3	54LS244DMQB	EvalCode: N		

Action Items
Evaluations
Solutions
Weapon Sys Hierarchy
Parts Engineering

**DMS\* Prototype Demonstration**

Events   Reset   Exit

**DMSMS Management System (DMS\*) - User 1**

**Action Items**





New   Edit   Delete   Prioritize

1	17-Feb-1995	Check suppliers for part 54LS244DMQB of unit UnitB.		
2	16-Feb-1995	Identify predictive family for part AT28MC010-12MMB of unit U		

User Name: Dave Jones   Organization: NAVSEA   Date: 17-Feb-1995

**Important Notices**

Edit	Save	Delete	Prioritize			
1	17-Feb-1995	Unit3	54LS244DMQB	EvalCode: N		

Action Items
Evaluations
Solutions
Weapon Sys Hierarchy
Parts Engineering

**DMS\* Prototype Demonstration**

Events Reset Exit

**DMSMS Management System (DMS\*) - User 1**

**Action Items**

New Edit Delete Prioritize

**Check Suppliers**

List of vendor parts for part 54LS244DMQB of unit UnitB

Vendor Part	Active	DMS date is set	Discontinued
Call FAIRECHILD SEMICONDUCTOR CORP NORTH AMERICAN SALES at (392) 292-8313 to see if the part 54LS244DMQB is still manufactured.	●	●	●
Call THERMAL CIRCUITS INC at (696) 892-6311 to see if the part 54LS244DMQB is still manufactured.	●	●	●

---

User Name: Dave Jones      Organization: NAVSEA      Date: 17-Feb-1995

**Important Notices**

Edit	Save	Delete	Prioritize		
1	17-Feb-1995	Unit3	54LS244DMQB	EvalCode:	N

  
Action Items

  
Evaluations

  
Solutions

  
Weapon Sys Hierarchy

  
Parts Engineering

**DMS\* Prototype Demonstration**

Events Reset Exit

**DMSMS Management System (DMS\*) - User 1**

**Action Items**

New Edit Delete Prioritize

1 16-Feb-1995 Identify predictive family for part AT28MC01B-12MMB of unit

---

User Name: Dave Jones      Organization: NAVSEA      Date: 17-Feb-1995

**Important Notices**

Edit	Save	Delete	Prioritize		
1	17-Feb-1995	Unit3	54LS244DMQB	EvalCode:	N

  
Action Items

  
Evaluations

  
Solutions

  
Weapon Sys Hierarchy

  
Parts Engineering

**DMS\* Prototype Demonstration**

Events    Reset    Exit

**DMSMS Management System [DMS\*] - User 1**

**Action Items**

New    Edit    Delete    Prioritize

17-Feb-1995    Choose a predictive family:    2MB of unit 1

Cancel
OK

**DMS\* Prototype Demonstration**

Events    Reset    Exit

**DMSMS Management System [DMS\*] - User 1**

**Action Items**

New    Edit    Delete    Prioritize

17-Feb-1995    Choose a predictive family:    2MB of unit 1

**Important Notices**

Edit	Save	Delete	Prioritize		
1	17-Feb-1995	Unit3	54LS244DMQB	EvalCode: N	

  
Action Items

  
Evaluations

  
Solutions

  
Weapon Sys Hierarchy

  
Parts Engineering

**DMS\* Prototype Demonstration**

Events    Reset    Exit

**DMSMS Management System [DMS\*] - User 1**

**Action Items**

New    Edit    Delete    Prioritize

17-Feb-1995    Choose a predictive family:    2MB of unit 1

**Important Notices**

Edit	Save	Delete	Prioritize		
1	17-Feb-1995	Unit3	54LS244DMQB	EvalCode: N	

**Choose a predictive family:**

- CMOS 1M EEPROM
- CMOS 16K EEPROM 2K X 8
- CMOS 64K EEPROM 8K X 8
- CMOS 256K UV EEPROM 32K X 8
- CMOS 256K FLASH EEPROM 1988
- CMOS 512K UV EEPROM 512K
- CMOS 1M EEPROM
- CMOS 1M FLASH EEPROM 1990
- CMOS 2M EEPROM

  
Action Items

  
Evaluations

  
Solutions

  
Weapon Sys Hierarchy

  
Parts Engineering

**DMS\* Prototype Demonstration**

Events Reset Exit

**DMSMS Management System (DMS\*) - User 1**





**Action Items**

New Edit Delete Prioritize

User Name: Dave Jones      Organization: NAVSEA      Date: 17-Feb-1995

**Important Notices**

Edit	Save	Delete	Prioritize		
1	17-Feb-1995	Unit3	54LS244DMQB	EvalCode: N	

Action Items      Evaluations      Solutions      Weapon Sys Hierarchy      Parts Engineering

**DMS\* Prototype Demonstration**

Events Reset Exit





**DMS Notice...**      **DMSMS Management System (DMS\*) - User 1**

Supplier Leaves...      Units Parts Help

Change Date...      Organization: NAVAIR      Date: 17-Feb-1995

**Important Notices**

Edit	Save	Delete	Prioritize		
1	17-Feb-1995	UnitC	AT28MC010-12MMB	EvalCode: S	
2	17-Feb-1995	UnitB	54LS244DMQB	EvalCode: N	
3	16-Feb-1995	UnitB	26LS32/BEAJC	EvalCode: S	

Action Items      Evaluations      Solutions      Weapon Sys Hierarchy      Parts Engineering





**DMSMS Management System (DMS\*) - User 2**

File WeaponSystems Units Parts Help

User Name: Dave Jones      Organization: NAVSEA      Date: 17-Feb-1995

**Important Notices**

Edit	Save	Delete	Prioritize		
1	17-Feb-1995	Unit3	54LS244DMQB	EvalCode: N	

Action Items      Evaluations      Solutions      Weapon Sys Hierarchy      Parts Engineering

**DMS<sup>1</sup> Prototype Demonstration**

Events Reset Exit

**DMSMS Management System (DMS<sup>1</sup>) - User 1**

File WeaponSystems Units Parts Help

User Name: Jeff Wilson      Organization: NAVAIR      Date: 17-Feb-1995

**Important Notices**

Edit	Save	Delete	Prioritize			
1	17-Feb-1995	UnitC	AT28MC010-12MMB	EvalCode: S		
2	17-Feb-1995	UnitB	54LS244DMQB	EvalCode: N		
3	16-Feb-1995	UnitB	26LS32/BEAJC	EvalCode: S		

**DMS Notice Form**

Part Number:

Manufacturer:

Date:

User Name: Dave Jones      Organization: NAVAIR      Date: 17-Feb-1995

**Important Notices**

Edit	Save	Delete	Prioritize			
1	17-Feb-1995	Unit3	54LS244DMQB	EvalCode: N		

**DMS<sup>1</sup> Prototype Demonstration**

Events Reset Exit

**DMSMS Management System (DMS<sup>1</sup>) - User 1**

File WeaponSystems Units Parts Help

User Name: Jeff Wilson      Organization: NAVAIR      Date: 17-Feb-1995

**Important Notices**

Edit	Save	Delete	Prioritize			
1	17-Feb-1995	UnitC	AT28MC010-12MMB	EvalCode: S		
2	17-Feb-1995	UnitB	54LS244DMQB	EvalCode: N		
3	16-Feb-1995	UnitB	26LS32/BEAJC	EvalCode: S		

**DMSMS Management System (DMS<sup>1</sup>) - User 2**

File WeaponSystems Units Parts Help

User Name: Dave Jones      Organization: NAVSEA      Date: 17-Feb-1995

**Important Notices**

Edit	Save	Delete	Prioritize			
1	17-Feb-1995	Unit3	SNJ54HC00J	EvalCode: N		
2	17-Feb-1995	Unit3	54LS244DMQB	EvalCode: N		

**DMS<sup>3</sup> Prototype Demonstration**

Events Reset Exit





**DMSMS Management System (DMS<sup>3</sup>) - User 1**

File WeaponSystems Units Parts Help

User Name: Jeff Wilson      Organization: NAVAIR      Date: 17-Feb-1995

**Important Notices**

Edit	Save	Delete	Prioritize			
1	17-Feb-1995	UnitC	AT28MC010-12MMB	EvalCode: S		
2	17-Feb-1995	UnitB	54LS244DMQB	EvalCode: N		
3	16-Feb-1995	UnitB	26LS32/BEAJC	EvalCode: S		

 Action Items     
  Evaluations     
  Solutions     
  Weapon Sys Hierarchy     
  Parts Engineering

---





**DMSMS Management System (DMS<sup>3</sup>) - User 2**

File WeaponSystems Units Parts Help

User Name: Dave Jones      Organization: NAVSEA      Date: 17-Feb-1995

**Important Notices**

Edit	Delete	Prioritize			
1	17 To file	Unit3	SNJ54HC00J	EvalCode: N	
2	17 To case	Unit3	54LS244DMQB	EvalCode: N	

 Action Items     
  Evaluations     
  Solutions     
  Weapon Sys Hierarchy     
  Parts Engineering

**Solutions: Case 19**

Case Resolution

Part Number:       Vendor:

Systems:       Units:

**SOLUTIONS:**

Type:       Cost:

Case Log:

17-Feb-1995      CASE OPENED

**Solutions: Case 19**

<b>Case Resolution</b>	
New Edit... Delete	Vendor: TEXAS INSTRUMENTS INC
Find Similar Cases <b>List Other Affected Systems</b>	Units: Unit3

**SOLUTIONS:**

Type:	Cost:
<input style="width: 100%;" type="text"/>	<input style="width: 100%;" type="text"/>

**Case Log:**

17-Feb-1995    CASE OPENED

**Solutions: Case 19**

<b>Case Resolution</b>	
Part Number: SNJ54HC00J	Vendor: TEXAS INSTRUMENTS INC

System	<table border="1" style="width: 100%; border-collapse: collapse;"> <tr> <th colspan="2" style="text-align: center;">Affected Systems</th> </tr> <tr> <td style="width: 30%;">System?</td> <td>Field telecom prototype</td> </tr> <tr> <td>System12</td> <td>X-4 radar</td> </tr> </table>	Affected Systems		System?	Field telecom prototype	System12	X-4 radar
Affected Systems							
System?	Field telecom prototype						
System12	X-4 radar						

**Case Log:**

17-Feb-1995    CASE OPENED

Solutions: Case19

**Case Resolution**

Part Number:  Vendor:

System:  Manager Info

Ted Gates is the manager of system System9.  
The manager can be reached at (483) 213-3800.

Case Log:

17-Feb-1995 CASE OPENED

Solutions: Case19

**Case Resolution**

New	<input type="text"/>	Vendor:	<input type="text" value="TEXAS INSTRUMENTS INC"/>
Edit...	<input type="text"/>	Units:	<input type="text" value="Unit3"/>
Delete	<input type="text"/>		
<b>Find Similar Cases</b>	<input type="text"/>		
List Other Affected Systems	<input type="text"/>		

**SOLUTIONS:**

Type:	Cost:
<input type="text"/>	<input type="text"/>

Case Log:

17-Feb-1995 CASE OPENED

**Solutions: Case19**

**Case Resolution**

Part Number:  Vendor:

---

**Similar Cases**

Case 135 Manufacturer: NATIONAL SEMICONDUCTOR  
 Part Number: MM54HC00J/883B

Systems: Radar Units: Unit 345  
 Unit BQ3

Solution  
 Type: LOT Buy Cost: \$ 95.00 per part

---

Case 23 Manufacturer: TEXAS INSTRUMENTS  
 Part Number: SNJ54HC00W

Systems: System 54 Units: Unit C5A

Solution  
 Type: Substitution Cost: NA

---

Case 310 Manufacturer: MOTOROLA  
 Part Number: 54HC58/BCAJC

Systems: SQQ-89 Units: Unit X34  
 Unit X35A

Solution  
 Type: Emulation Cost: \$1100 per part

**Solutions: Case19**

**Case Resolution**

New  
 Edit...  
 Delete  
 Find Similar Cases  
 List Other Affected Systems

Vendor:

Units:

**SOLUTIONS:**

Type:

Cost:

**Case Log**

17-Feb-1995 CASE OPENED

Solutions: Case19

**Case Resolution**

Part Number: SNJ54HC00J      Vendor: TEXAS INSTRUMENTS INC

System: System2      Units: Unit3

**SOLUTIONS:**

Case Edit

Select a case to edit: Case12      Case12

OK    Cancel    Reset

Case Log:  
17-Feb-1995

Solutions: Case12

**Case Resolution**

Part Number: 6134459-1      Vendor: Plessey

System: Sonar      Units: Unit116  
Unit118  
Unit31

**SOLUTIONS:**

Type: Reclaim      Cost: SeeCaseLog

Case Log:  
02/08/93

Using configuration manuals, application of 2833450 was identified in Unit 31 of E(U)4, Unit 116 of B,C,D,E(U)3, Unit 118 of C,D,E(U)3, and Units 016 and 017 of BQQ-6.

Support requirements thru 2005 will require 75 pcs of 6134459-1.

Plessey was contacted and verified this device has been "archived". It may be possible to have a production run made if requirements are sufficient to warrant.

No sub/alt part or SOS can be identified.

03/10/93

Discussed requirements for the next higher assembly with supply support

**DMS\* Prototype Demonstration**

Events Reset Exit

DMS Notice... **DMSMS Management System [DMS\*] - User 1**

Supplier Leaves... Units Parts Help

Change Date... Organization: NAVAIR Date: 17-Feb-1995

**Important Notices**

Edit	Save	Delete	Prioritize		
1	17-Feb-1995	UnitC	AT28MC010-12MMB	EvalCode: S	
2	17-Feb-1995	UnitB	54LS244DMQB	EvalCode: N	
3	16-Feb-1995	UnitB	26LS32/BEAJC	EvalCode: S	

Action Items Evaluations Solutions Weapon Sys Hierarchy Parts Engineering

**DMSMS Management System [DMS\*] - User 2**

File WeaponSystems Units Parts Help

User Name: Dave Jones Organization: NAVSEA Date: 17-Feb-1995

**Important Notices**

Edit	Save	Delete	Prioritize		
1	17-Feb-1995	Unit3	SNJ54HC001	EvalCode: N	
2	17-Feb-1995	Unit3	54LS244DMQB	EvalCode: N	

Action Items Evaluations Solutions Weapon Sys Hierarchy Parts Engineering

**DMS\* Prototype Demonstration**

Events Reset Exit

Change Date

The date is currently: 17-Feb-1995

File Weap User Name: Je Organization: NAVSEA Date: 17-Feb-1995

Increment by fixed interval  
 Enter new date

Enter date: 15-May-1995

Action Items Evaluations Solutions Weapon Sys Hierarchy Parts Engineering

**DMSMS Management System [DMS\*] - User 2**

File WeaponSystems Units Parts Help

User Name: Dave Jones Organization: NAVSEA Date: 17-Feb-1995

**Important Notices**

Edit	Save	Delete	Prioritize		
1	17-Feb-1995	Unit3	SNJ54HC001	EvalCode: N	
2	17-Feb-1995	Unit3	54LS244DMQB	EvalCode: N	

Action Items Evaluations Solutions Weapon Sys Hierarchy Parts Engineering

**DMS<sup>+</sup> Prototype Demonstration**

Events   Reset   Exit

---

**DMSMS Management System (DMS<sup>+</sup>) - User 1**

File   WeaponSystems   Units   Parts   Help

User Name: Jeff Wilson      Organization: NAVAIR      Date: 15-May-1995

**Important Notices**

Edit   Save   Delete   Prioritize

1	15-May-1995	UnitB	IDT6116SA150TDB	EvalCode: 0
---	-------------	-------	-----------------	-------------

  
Action Items

  
Evaluations

  
Solutions

  
Weapon Sys Hierarchy

  
Parts Engineering





**DMSMS Management System (DMS<sup>+</sup>) - User 2**

File   WeaponSystems   Units   Parts   Help

User Name: Dave Jones      Organization: NAVSEA      Date: 15-May-1995

**Important Notices**

Edit   Save   Delete   Prioritize

**DMS<sup>+</sup> Prototype Demonstration**

Events   Reset   Exit

---

**DMSMS Management System (DMS<sup>+</sup>) - User 1**

**Action Items**





New   Edit   Delete   Prioritize

1	15-May-1995	Check suppliers for part 54LS244DMQB of unit Unit3.
2	17-Feb-1995	Check suppliers for part SNJ54HC00J of unit Unit3.
3	17-Feb-1995	Verify DMS notice for TEXAS I SNJ54HC00J on 1-Feb-1995.

User Name: Dave Jones      Organization: NAVSEA      Date: 15-May-1995

**Important Notices**

Edit   Save   Delete   Prioritize

**DMS\* Prototype Demonstration**

Events    Reset    Exit

**DMSMS Management System (DMS\*) - User 1**

**Action Items**

New	Edit	Delete	Prioritize	
1	15-May-1995		By # systems affected	part 54LS244DMQB of unit Unit3.
2	17-Feb-1995			part SNJ54HC00J of unit Unit3.
3	17-Feb-1995		By date	TEXAS I SNJ54HC00J on 1-Feb-1995.

User Name: Dave Jones      Organization: NAVSEA      Date: 15-May-1995

**Important Notices**

Edit    Save    Delete    Prioritize

  
 Action Items

  
 Evaluations

  
 Solutions

  
 Weapon Sys Hierarchy

  
 Parts Engineering

**DMS\* Prototype Demonstration**

Events    Reset    Exit

**DMSMS Management System (DMS\*) - User 1**

**Action Items**

New	Edit	Delete	Prioritize	
1		3		Verify DMS notice for TEXAS I SNJ54HC00J on 1-Feb-1995.
2		1		Check suppliers for part SNJ54HC00J of unit Unit3.
3		1		Check suppliers for part 54LS244DMQB of unit Unit3.

User Name: Dave Jones      Organization: NAVSEA      Date: 15-May-1995

**Important Notices**

Edit    Save    Delete    Prioritize

  
 Action Items

  
 Evaluations

  
 Solutions

  
 Weapon Sys Hierarchy

  
 Parts Engineering

**DMS\* Prototype Demonstration**

Events    Reset    Exit

**DMSMS Management System (DMS\*) - User 1**

**Action Items**

New	Edit	Delete	Prioritize	
1		3	Ver	By # systems affected
2		1	Che	AS I SNJ54HC00J on 1-Feb-1995.
3		1	Che	SNJ54HC00J of unit Unit3.
				54LS244DMQB of unit Unit3.

User Name: Dave Jones      Organization: NAVSEA      Date: 15-May-1995

**Important Notices**

Edit    Save    Delete    Prioritize

  
 Action Items

  
 Evaluations

  
 Solutions

  
 Weapon Sys Hierarchy

  
 Parts Engineering

**DMS\* Prototype Demonstration**

Events    Reset    Exit

**DMSMS Management System (DMS\*) - User 1**

**Action Items**

New	Edit	Delete	Prioritize	
1				15-May-1995    Check suppliers for part 54LS244DMQB of unit Unit3.
2				17-Feb-1995    Check suppliers for part SNJ54HC00J of unit Unit3.
3				17-Feb-1995    Verify DMS notice for TEXAS I SNJ54HC00J on 1-Feb-1995.

User Name: Dave Jones      Organization: NAVSEA      Date: 15-May-1995

**Important Notices**

Edit    Save    Delete    Prioritize

  
 Action Items

  
 Evaluations

  
 Solutions

  
 Weapon Sys Hierarchy

  
 Parts Engineering

**DMS\* Prototype Demonstration**

Events Reset Exit

DMS Notice... DMSMS Management System (DMS\*) - User 1

Supplier Leaves... Units Parts Help

Change Date... Organization: NAVAIR Date: 15-May-1995

**Important Notices**

Edit Save Delete Prioritize

1	15-May-1995	Unit D	IDT6116SR150TDB	EvalCode: 0
---	-------------	--------	-----------------	-------------

Action Items Evaluations Solutions Weapon Sys Hierarchy Parts Engineering

**DMSMS Management System (DMS\*) - User 2**

File WeaponSystems Units Parts Help

User Name: Dave Jones Organization: NAVSEA Date: 15-May-1995

**Important Notices**

Edit Save Delete Prioritize

Action Items Evaluations Solutions Weapon Sys Hierarchy Parts Engineering

**DMS\* Prototype Demonstration**

Events Reset Exit

**DMSMS Management System (DMS\*) - User 1**

File WeaponSystems Units Parts Help

User Name: Jeff Wilson Organization: NAVAIR Date: 15-May-1995

**Important Notices**

Edit Save Delete Prioritize

Supplier Leaves

Supplier: MOTOROLA INC MOTOROLA INC

Date leaving: 1-JUN-1995

Supplier's parts to discontinue: Military parts Military parts

OK Cancel Reset

Action Items Evaluations Solutions Weapon Sys Hierarchy Parts Engineering

**DMS<sup>+</sup> Prototype Demonstration**

Events Reset Exit





**DMSMS Management System (DMS<sup>+</sup>) - User 1**

File WeaponSystems Units Parts Help

User Name: Jeff Wilson      Organization: NAVAIR      Date: 15-May-1995

**Important Notices**

Edit	Save	Delete	Prioritize			
1	15-May-1995	UnitB	IDT71256S100DB	EvalCode: N		
2	15-May-1995	UnitB	IDT6116SA150TDB	EvalCode: 0		

 Action Items     
  Evaluations     
  Solutions     
  Weapon Sys Hierarchy     
  Parts Engineering





**DMSMS Management System (DMS<sup>+</sup>) - User 2**

File WeaponSystems Units Parts Help

User Name: Dave Jones      Organization: NAVSEA      Date: 15-May-1995

**Important Notices**

Edit	Save	Delete	Prioritize			

 Action Items     
  Evaluations     
  Solutions     
  Weapon Sys Hierarchy     
  Parts Engineering

**DMS<sup>+</sup> Prototype Demonstration**

Events Reset Exit

**DMSMS Management System (DMS<sup>+</sup>) - User 1**

**Action Items**





New	Edit	Delete	Prioritize				
1	15-May-1995	Check suppliers for part IDT71256S100DB of unit UnitB.					
2	15-May-1995	Verify DMS notice for MOTOROL 6206C-100/BXAJC on 1-Jun-1995.					
3	15-May-1995	Verify DMS notice for MOTOROL 26LS32/BEAJC on 1-Jun-1995.					
4	15-May-1995	Check suppliers for part 54LS244DMQB of unit UnitB.					

**DMSMS Management System (DMS<sup>+</sup>) - User 1**

User Name: Dave Jones      Organization: NAVSEA      Date: 15-May-1995

**Important Notices**

Edit	Save	Delete	Prioritize			

 Action Items     
  Evaluations     
  Solutions     
  Weapon Sys Hierarchy     
  Parts Engineering

**DMS<sup>3</sup> Prototype Demonstration**

Events Reset Exit

**DMSMS Management System (DMS<sup>3</sup>) - User 1**





File **WeaponSystems** Units Parts Help

User N **New...** Organization: NAVAIR Date: 15-May-1995

**Edit...** Important Notices

**Delete...** Prioritize

1	15-May-1995	UnitB	IDT71256S100DB	EvalCode: N
2	15-May-1995	UnitB	IDT6116SA150TDB	EvalCode: 0

 Action Items
  Evaluations
  Solutions
  Weapon Sys Hierarchy
  Parts Engineering

  
 DMSMS Management System (DMS<sup>3</sup>) - User 2

**DMS<sup>3</sup> Prototype Demonstration**

Events Reset Exit

**DMSMS Management System (DMS<sup>3</sup>) - User 1**

File **WeaponSystems** Units Parts Help



User Name: Jeff Wilson Organization: NAVAIR Date: 15-May-1995

**Important Notices**

Edit	Save	Delete	Prioritize			
1	15-May-1995	UnitB	IDT71256S100DB	EvalCode: N		
2	15-May-1995	UnitB	IDT6116SA150TDB	EvalCode: 0		

**Edit Entry**

Enter name of system to edit:

 Action Items
  Parts Engineering

  
 DMSMS Management System (DMS<sup>3</sup>) - User 2

**DMS\* Prototype Demonstration**

Events    Reset    Exit

---

**System: System1**

---

**File**    **User Nam**

**Description:**        **Date:** 15-May-1995

**Program Manager:**   

**Reliability:**   

---

**Units**

Qty	Name	Description
1	UnitA	Amplifier
1	UnitB	Relay
1	UnitC	Receiver

Parts Engineering

System (DMS\*) -  
User 2

**DMS\* Prototype Demonstration**

Events    Reset    Exit

---

**System: System1**

---

**File**    **User Nam**

**Unit: UnitB**

**Description:**        **Date:** 15-May-1995

**Manager:**   

**Reliability:**   

---

**Parts**

Qty	Name	Description
1	26LS32/BEAJC	BUS/LINE RECEIWER, DIFF
1	54F175DMQB	D-TYPE FLIP-FLOP, QUADRUPL
1	AD664TD-UNI/883B	D/A CONVERTER, 12-BIT, QUAD
1	IDT612533100DB	STATIC RAM
1	IDT6116SA150TDB	STATIC RAM
1	54LS244DMQB	BUFFER & BUS/LOGIC DRIVER,

Parts Engineering

DMS<sup>+</sup> Prototype Demonstration

Events Reset Exit

System: System1

Unit: UnitB

File V

User Nam

Date: 15-May-1995

Description: Relay

Unit: UnitB

Part Number:

NSN:

Drawing Number:

Manufacturer:

OK Cancel Reset

1

2

Action I

Parts Engineering

Edit Unit Details Add Part

DMS<sup>+</sup> Prototype Demonstration

Events Reset Exit

System: System1

Unit: UnitB

Unit: UnitB PartNumber: IDT71256S100DB

Date: 15-May-1995

Description: STATIC RAM

Equivalent Parts:

Vendor	Part Number
INTEGRATED DEVI	IDT71256S100DB
AUSTIN SEMICOND	MT5C2568CW-100883
MOTOROLA INC	6206C-100/BXAJC
MATRA-HARRIS SE	HM1E-65756NMB

Edit Details Add Equal Part

1

2

Action I

Parts Engineering

Edit Unit Details Add Part

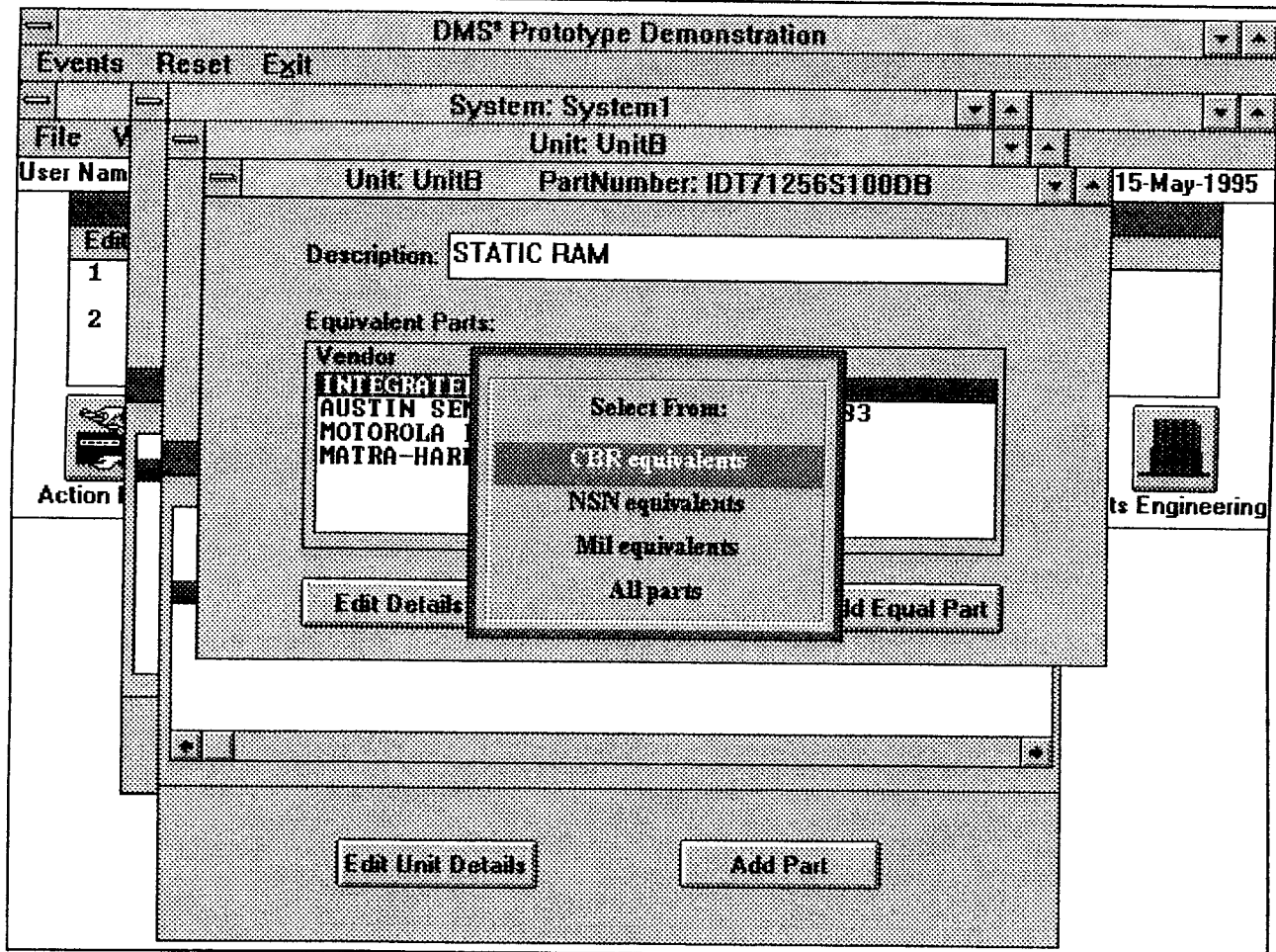
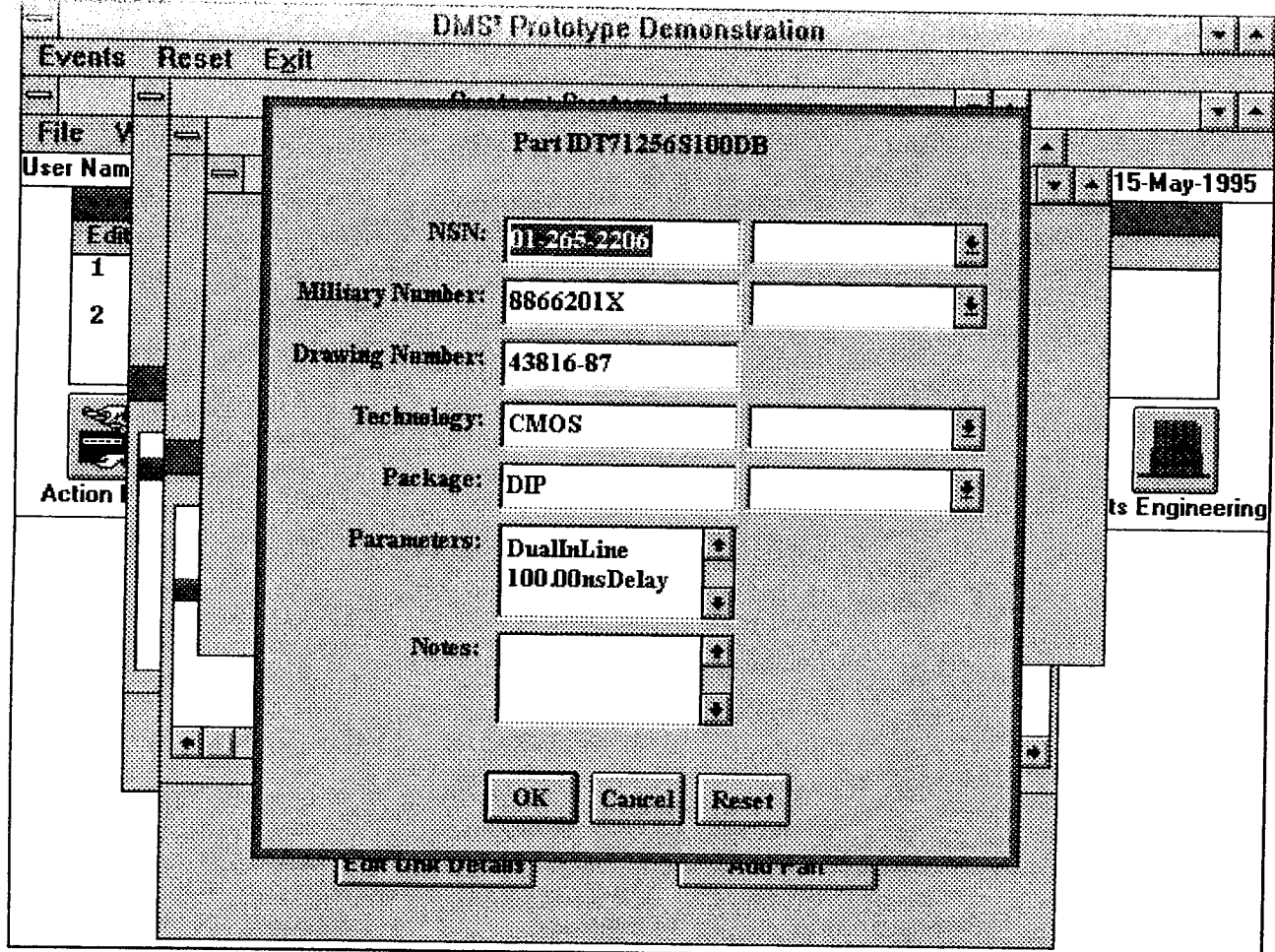

DMS\* Prototype Demonstration

Events Reset Exit

System: System1

Unit: UnitB

User Name: Unit: UnitB PartNumber: IDT71256S100DB 15-May-1995

Description: STATIC RAM

Equivalent Parts:

Vendor	Part Number
INTEGRATED DEVI	IDT71256S100DB
AUSTIN SEMICOND	MT5C2568CW-100883
MOTOROLA INC	6206C-100/BXAJC
MATRA-HARRIS SE	HM1E-65756NMB

Select similar parts to add to the above list:

Vendor	Part Number
MICRON TECHNOLO	MT5C2568C-100
INTEGRATED DEVI	IDT71256S100TCB
INTEGRATED DEVI	IDT71256S100L28B
INTEGRATED DEVI	IDT71256S100L32B
AUSTIN SEMICOND	MT5C2568ECW-100883
INTEGRATED DEVI	IDT71256S100XEB
INOVA MICROELEC	S32K8-100MC

Cancel OK

DMS\* Prototype Demonstration

Events Reset Exit

System: System1

Unit: UnitB

User Name: Unit: UnitB PartNumber: IDT71256S100DB 15-May-1995

Description: STATIC RAM

Equivalent Parts:

Vendor	Part Number
INTEGRATED DEVI	IDT71256S100DB
AUSTIN SEMICOND	MT5C2568CW-100883
MOTOROLA INC	6206C-100/BXAJC
MATRA-HARRIS SE	HM1E-65756NMB

Select From: 83

- CBR equivalents
- NSN equivalents
- Mil equivalents
- All parts

Edit Details Add Equal Part

Edit Unit Details Add Part

DMS\* Prototype Demonstration

Events Reset Exit

System: System1

Unit: UnitB

Unit: UnitB PartNumber: IDT71256S100DB 15-May-1995

Description: STATIC RAM

Equivalent Parts:

Vendor	Part Number
INTEGRATED DEVI	IDT71256S100DB
AUSTIN SEMICOND	MT5C2568CW-100883
MOTOROLA INC	6206C-100/BXAJC
MATRA-HARRIS SE	HM1E-65756NMB

Select similar parts to add to the above list:

Vendor	Part Number
MICRON TECHNOLO	MT5C2568C-100
OMNI-WAVE SEMIC	OW62256CD3-10
INOVA MICROELEC	S32K8-100MC

Cancel OK

DMS\* Prototype Demonstration

Events Reset Exit

System: System1

Unit: UnitB

Unit: UnitB PartNumber: IDT71256S100DB 15-May-1995

Description: STATIC RAM

Equivalent Parts:

Vendor	Part Number
INTEGRATED DEVI	IDT71256S100DB
AUSTIN SEMICOND	MT5C2568CW-100883
MOTOROLA INC	6206C-100/BXAJC
MATRA-HARRIS SE	HM1E-65756NMB

Select From:

- CBR equivalents
- NSN equivalents
- All equivalents
- All parts

Edit Details Add Equal Part

Edit Unit Details Add Part

DMS<sup>2</sup> Prototype Demonstration

Events    Reset    Exit

System: System1

Unit: UnitB

Unit: UnitB    PartNumber: IDT71256S100DB    15-May-1995

Description:

Equivalent Parts:

Vendor	Part Number
DMS <sup>2</sup>	

No new equivalents were found among the SMDs.

Events    Reset

Mfr: INTEGRATED DEVICE TECHNOLOGY INC    PartNum:

IDT71256S100DB

Description:

Generic Part Number:

Package Style:

Technology:

IHS Description:

IHS Technology:

Predictive Category:

Predictive Family:

Parameters:

DMS Notes:

**DMS<sup>2</sup> Prototype Demonstration**

Events    Reset    Exit

System: System1

File    View

User Name: \_\_\_\_\_    Date: 15-May-1995

Description: **NAVAIR demonstration system**

Program Manager: **Jeff Wilson**

Reliability: **Military**

**Units**

Qty	Name	Description
1	UnitA	Amplifier
1	UnitB	Relay
1	UnitC	Receiver

**Add Unit**

System (DMS<sup>2</sup>) - User 2

Parts Engineering

**DMS<sup>2</sup> Prototype Demonstration**

Events    Reset    Exit

System: System1

File    View

User Name: \_\_\_\_\_    Date: 15-May-1995

Unit: UnitA

Description: **Amplifier**

Manager: **Ken Dunn**

Reliability: **Military**

**Parts**

Qty	Name	Description
1	DG202AK/883B	ANALOG SWITCH, SPST, QUAD.
1	1595/BCAJC	ANALOG MULTIPLIER/SQUARER
1	XC2018-33PG84B	FIELD PROGRAMMABLE GATE ARR
1	MD28F020-20/B	EEPROM, FLASH

**Edit Unit Details**      **Add Part**

Parts Engineering

DMS<sup>3</sup> Prototype Demonstration

Events    Reset    Exit

System: System1

Unit: UnitA

User Name: \_\_\_\_\_ Date: 15-May-1995

Description:

Manager:

Reliability:

New Part Information:

Part name:

Quantity:

Qty	Name	Description
1	DG202A	SPST, QUAD, ER/SQUARER
1	1595/B	ER/SQUARER
1	XC2018	BLE GATE ARR
1	MD28F0	

Parts Engineering

DMS<sup>3</sup> Prototype Demonstration

Events    Reset    Exit

System: System1

Unit: UnitA

User Name: \_\_\_\_\_ Date: 15-May-1995

Description:

Manager:

Reliability:

Parts		
Qty	Name	Description
1	DG202AK/883B	ANALOG SWITCH, SPST, QUAD,
1	1595/BCAJC	ANALOG MULTIPLIER/SQUARER
1	XC2018-33PG84B	FIELD PROGRAMMABLE GATE ARR
1	MD28F020-20/B	EEPROM, FLASH
1	7802301ME	ANALOG SWITCH, SPST, QUAD,

Parts Engineering

DMS<sup>+</sup> Prototype Demonstration

Events    Reset    Exit

System: System1

Unit: UnitA

User Name:    Unit: UnitA    PartNumber: 7802301ME    15-May-1995

1    Edit

2

Description: **LINE DRIVER/TRANSMITTER, DIFF**

Equivalent Parts:

Vendor	Part Number
MOTOROLA INC	26LS31/BEAJC
PHILIPS SEMICON	26LS31/BEA
NATIONAL SEMICO	DS26LS31MJ/883
ADVANCED MICRO	AM26LS31/BEA

Action    ts Engineering

Edit Details    Add Equal Part

Edit Unit Details    Add Part

DMS<sup>+</sup> Prototype Demonstration

Events    Reset    Exit

Part 7802301ME

User Name:    15-May-1995

1    Edit

2

NSN:

Military Number:

Drawing Number:

Technology:

Package:

Parameters:

Notes:

OK    Cancel    Reset

Edit Unit Details    Add Part

Action    ts Engineering

DMS\* Prototype Demonstration

Events Reset Exit

System: System1

Unit: UnitA

User Name: [ ] Date: 15-May-1995

Description: Amplifier

Manager: Ken Dunn

Reliability: Military

**New Part Information:**

Part name: 01-253-4263

Quantity: 1

OK Cancel Reset

Qty	Name
1	DG202A
1	1595/B
1	XC2018
1	MD28F0
1	7802301

SPST, QUAD, ER/SQUARER, BLE GATE ARR, NSM111111, D

Parts Engineering

Edit Unit Details Add Part

DMS\* Prototype Demonstration

Events Reset Exit

System: System1

Unit: UnitA

User Name: [ ] Date: 15-May-1995

Description: Amplifier

Manager: Ken Dunn

Reliability: Military

**Parts**

Qty	Name	Description
1	DG202AK/883B	ANALOG SWITCH, SPST, QUAD.
1	1595/BCAJC	ANALOG MULTIPLIER/SQUARER
1	XC2018-33PG84B	FIELD PROGRAMMABLE GATE ARR
1	MD28F020-20/B	EEPROM, FLASH
1	7802301ME	LINE DRIVER/TRANSMITTER, DI
1	01-253-4263	SWITCH MODE SUPPLY CIRCUIT

Parts Engineering

Edit Unit Details Add Part

DMS<sup>®</sup> Prototype Demonstration

Events Reset Exit

System: System1

File V

Unit: UnitA

User Nam

Unit: UnitA PartNumber: 01-253-4263 15-May-1995

Description: SWITCH-MODE SUPPLY CIRCUIT

Equivalent Parts:

Vendor	Part Number
SEAGATE MICROEL	IP1526J/883B
LINEAR TECHNOLO	LT1526J
LINFINITY MICRO	SG1526J/883
UNITRODE INTEGR	UC1526J/883
MOTOROLA INC	1526/BUAJC

ts Engineering

Edit Details Add Equal Part

Edit Unit Details Add Part

DMS<sup>®</sup> Prototype Demonstration

Events Reset Exit

Part01-253-4263

File V

User Nam

15-May-1995

NSN: 01-253-4263

Military Number:

Drawing Number:

Technology: BIPOLAR

Package: DIP

Parameters:

Notes:

ts Engineering

OK Cancel Reset

Edit Unit Details Add Part

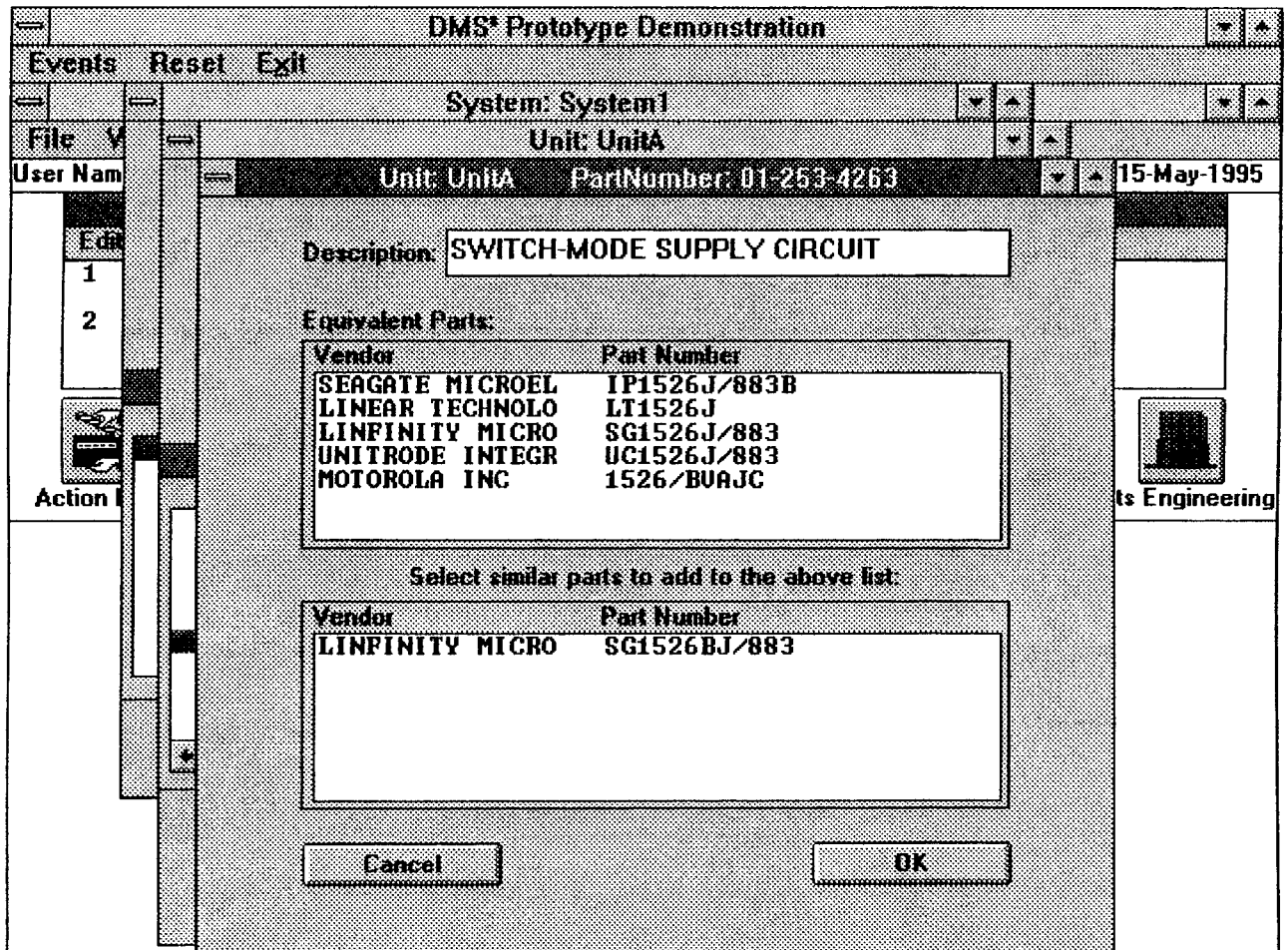
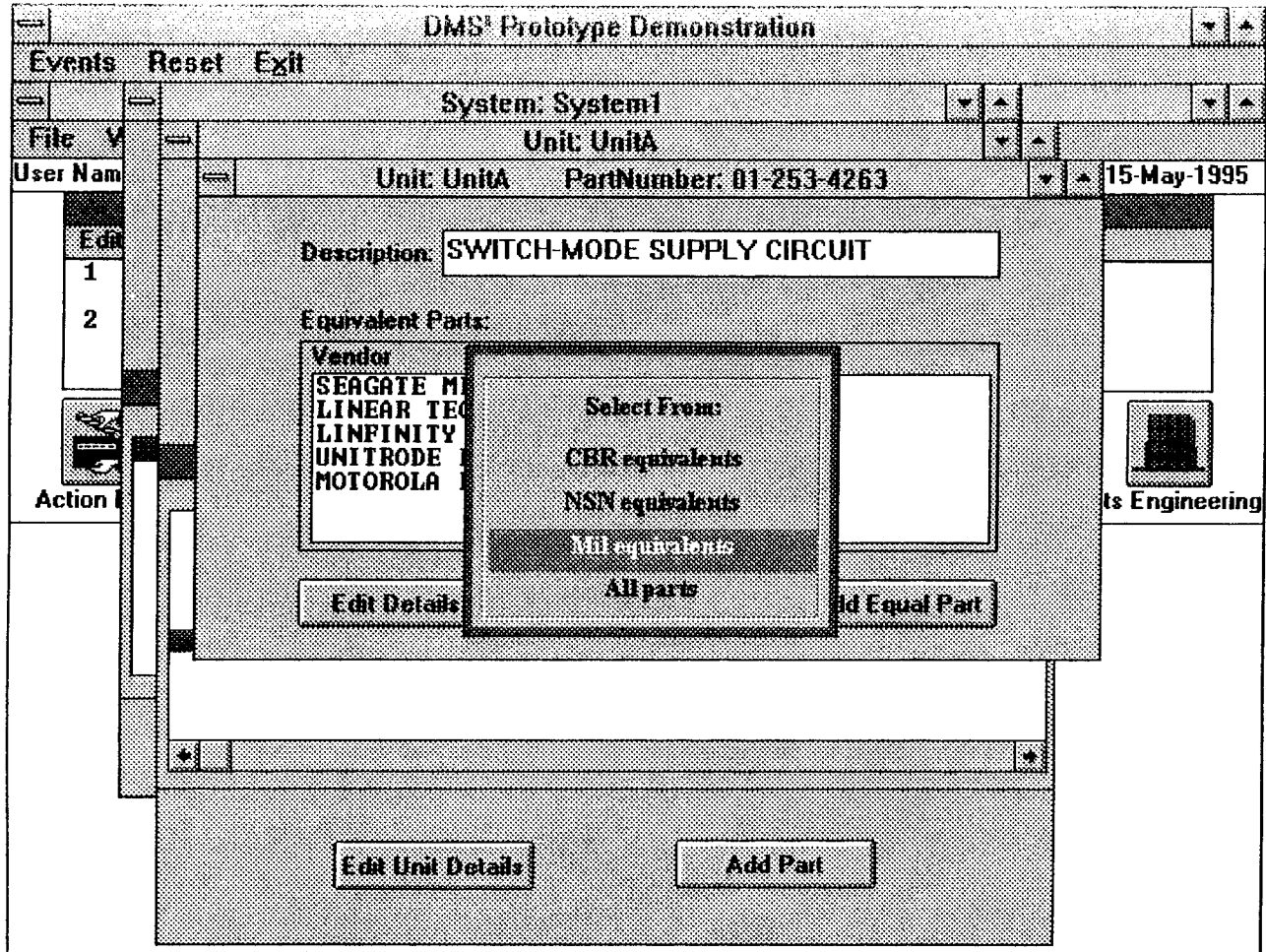

DMS\* Prototype Demonstration

Events    Reset    Exit

System: System1

Unit: UnitA

User Name: \_\_\_\_\_ Date: 15-May-1995

Description:

Manager:

Reliability:

New Part Information:

Part name:

Quantity:

Qty	Name	Description
1	DG202A	ANALOG SWITCH, SPST, QUAD,
1	1595/B	ANALOG MULTIPLIER/SQUARER
1	XC2018	FIELD PROGRAMMABLE GATE ARR
1	MD28F0	EEPROM, FLASH
1	780230	LINE DRIVER/TRANSMITTER, DI
1	01-253	SWITCH-MODE SUPPLY CIRCUIT

Parts Engineering

DMS\* Prototype Demonstration

Events    Reset    Exit

System: System1

Unit: UnitA

User Name: \_\_\_\_\_ Date: 15-May-1995

Description:

Manager:

Reliability:

Parts		
Qty	Name	Description
1	DG202AK/883B	ANALOG SWITCH, SPST, QUAD,
1	1595/BCAJC	ANALOG MULTIPLIER/SQUARER
1	XC2018-33PG84B	FIELD PROGRAMMABLE GATE ARR
1	MD28F020-20/B	EEPROM, FLASH
1	7802301ME	LINE DRIVER/TRANSMITTER, DI
1	01-253-4263	SWITCH-MODE SUPPLY CIRCUIT
1	PLDC20G10-30WM	EPROM, ONE-TIME PROGRAMMED

Parts Engineering



DMS<sup>+</sup> Prototype Demonstration

Events   Reset   Exit

System: System1

Unit: UnitA

User Name: Date: 15-May-1995

Description:

Manager:

Reliability:

**Parts**

Qty	Name	Description
1	DG202AK/883B	ANALOG SWITCH, SPST, QUAD,
1	1595/BCAJC	ANALOG MULTIPLIER/SQUARER
1	KC2018-33PG84B	FIELD PROGRAMMABLE GATE ARR
1	MD28F020-20/B	EEPROM, FLASH
1	7802301ME	LINE DRIVER/TRANSMITTER, DI
1	01-253-4263	SWITCH-MODE SUPPLY CIRCUIT
1	PLDC20G10-30WMB	EPLD, ONE-TIME-PROGRAMMED
1	8775501R	

Parts Engineering

DMS<sup>+</sup> Prototype Demonstration

Events   Reset   Exit

System: System1

Unit: UnitA

User Name: Date: 15-May-1995

Unit: UnitA    PartNumber: 8775501R

Description:

Equivalent Parts:

Vendor	Part Number

1	PLDC20G10-30WMB	EPLD, ONE-TIME-PROGRAMMED
1	8775501R	

DMS\* Prototype Demonstration

Events    Reset    Exit

DMSMS Management System (DMS\*) - User 1

Action Items

New	Edit	Delete	Prioritize
1	15-May-1995	Identify parts 8775501R of unit UnitA.	
2	15-May-1995	Check suppliers for part IDT71256S100DB of unit UnitB.	
3	15-May-1995	Verify DMS notice for MOTOROL 6206C-100/BXAJC on 1-Jun-1995.	
4	15-May-1995	Verify DMS notice for MOTOROL 26LS32/BEAJC on 1-Jun-1995.	
5	15-May-1995	Check suppliers for part 54LS244DMQB of unit UnitB.	



DMSMS  
Management  
System (DMS\*) -  
User 2

DMS\* Prototype Demonstration

Events    Reset    Exit

DMSMS Management System (DMS\*) - User 1

Action Items

New	Edit	Delete	Prioritize
1	15-May-1995	Check suppliers for part IDT71256S100DB of unit UnitB.	
2	15-May-1995	Verify DMS notice for MOTOROL 6206C-100/BXAJC on 1-Jun-1995.	
3	15-May-	<div style="border: 1px solid black; padding: 5px;"> <p style="text-align: center;">Research Part Number 8775501R</p> <p>The following SMDs are similar:</p> <p>8775901R 8755501R 8775901MR 7705701R 8775901S 87759012 8755501S 87555012 8775901MS 8775901M2 85515012 85515010 7705701S 8759401X</p> <p>No similar NSNs were found.</p> <p>No similar SCDs were found.</p> <p>The following vendor part numbers are similar:</p> <p>MC1555P1 SN75114J</p> </div>	
4	15-May-		

DMS<sup>2</sup> Prototype Demonstration

Events Reset Exit

DMSMS Management System (DMS<sup>2</sup>) - User 1

File WeaponSystems Units Parts Help

Parts Engineering

Research Part Definitions DB Utilities

System Action Items

New	Edit	Prioritize
12-Jul-95	Re-evaluate Unit3	54AC373DMQB (Eval Code A)
12-Jul-95	Re-evaluate Unit3	A1020B-PG84B (Eval Code A)
15-Jul-95	Re-evaluate UnitB	AD664TD-UNI/883B (Eval Code A)
2-Aug-95	Re-evaluate UnitB	54F175DMQB (Eval Code S)
2-Aug-95	Re-evaluate UnitB	IDT71256S100DB (Eval Code S)
10-Aug-95	Re-evaluate UnitB	LM185-1 2/883 (Eval Code A)



DMSMS  
Management  
System (DMS<sup>2</sup>) -  
User 2

DMS<sup>2</sup> Prototype Demonstration

Events Reset Exit

DMSMS Management System (DMS<sup>2</sup>) - User 1

File WeaponSystems Units Parts Help

Parts Engineering

Research Part Definitions DB Utilities

System Action Items

New	Edit	Prioritize
12-Jul-95	Re-evaluate Unit3	54AC373DMQB (Eval Code A)
12-Jul-95	Re-evaluate Unit3	A1020B-PG84B (Eval Code A)
15-Jul-95	Re-evaluate UnitB	AD664TD-UNI/883B (Eval Code A)
2-Aug-95	Re-evaluate UnitB	54F175DMQB (Eval Code S)
2-Aug-95	Re-evaluate UnitB	IDT71256S100DB (Eval Code S)
10-Aug-95	Re-evaluate UnitB	LM185-1 2/883 (Eval Code A)



DMSMS  
Management  
System (DMS<sup>2</sup>) -  
User 2

**DMS<sup>3</sup> Prototype Demonstration**

Events Reset Exit

**DMSMS Management System (DMS<sup>3</sup>) - User 1**

File WeaponSystems Units Parts Help

**Parts Engineering**

Research Part Definitions DB Utilities

**System Action Items**

New	Edit	Priorize
12-Jul-95		Re-evaluat
12-Jul-95		Re-evaluat
15-Jul-95		Re-evaluat
2-Aug-95		Re-evaluat
2-Aug-95		Re-evaluat
10-Aug-95		Re-evaluat

Enter part number to research

Part Number:

  
 DMSMS  
 Management  
 System (DMS<sup>3</sup>) -  
 User 2

**DMS<sup>3</sup> Prototype Demonstration**

Events Reset Exit

**DMSMS Management System (DMS<sup>3</sup>) - User 1**

File WeaponSystems Units Parts Help

**Parts Engineering**

Research Part Definitions DB Utilities

**Part Similarity**

Evaluation Method

Re-eval Frequency

**System Action Items**

New	Edit	
12-Jul-95		Re-evaluate Unit3 A1020B-PG84B <Eval Code A>
15-Jul-95		Re-evaluate UnitB AD664TD-UNI/883B <Eval Code A>
2-Aug-95		Re-evaluate UnitB 54F175DMQB <Eval Code S>
2-Aug-95		Re-evaluate UnitB IDT71256S100DB <Eval Code S>
10-Aug-95		Re-evaluate UnitB LM185-1 2/883 <Eval Code A>

  
 DMSMS  
 Management  
 System (DMS<sup>3</sup>) -  
 User 2

**DMS<sup>3</sup> Prototype Demonstration**

Events Reset Exit

**DMSMS Management System (DMS<sup>3</sup>) - User 1**

File WeaponSystems Units Parts Help

**Parts Engineering**

Research Part **Definitions** DB Utilities

		Part Similarity	Similarity Definition
New	Edit	Evaluation Method	Keywords
		Re-eval Frequency	Synonyms/Abbreviations
<del>12-Jul-95</del>			
12-Jul-95		Re-evaluate Unit3	A1020B-PG84B (Eval Code A)
15-Jul-95		Re-evaluate UnitB	AD664TD-UNI/883B (Eval Code A)
2-Aug-95		Re-evaluate UnitB	54F175DMQB (Eval Code S)
2-Aug-95		Re-evaluate UnitB	IDT71256S100DB (Eval Code S)
<del>10-Aug-95</del>		Re-evaluate UnitB	LM185-1 2/883 (Eval Code A)



DMSMS  
Management  
System (DMS<sup>3</sup>) -  
User 2

**DMS<sup>3</sup> Prototype Demonstration**

Events Reset Exit

**DMSMS Management System (DMS<sup>3</sup>) - User 1**

File WeaponSystems Units Parts Help

**Parts Engineering**

Research Part **Definitions** DB Utilities

		Part Similarity	System Action Items
New	Edit	Evaluation Method	
		Re-eval Frequency	
<del>12-Jul-95</del>			
12-Jul-95		Re-evaluate Unit3	A1020B-PG84B (Eval Code A)
15-Jul-95		Re-evaluate UnitB	AD664TD-UNI/883B (Eval Code A)
2-Aug-95		Re-evaluate UnitB	54F175DMQB (Eval Code S)
2-Aug-95		Re-evaluate UnitB	IDT71256S100DB (Eval Code S)
<del>10-Aug-95</del>		Re-evaluate UnitB	LM185-1 2/883 (Eval Code A)



DMSMS  
Management  
System (DMS<sup>3</sup>) -  
User 2

DMS\* Prototype Demonstration

Events Reset Exit

DMSMS Management System (DMS\*) - User 1

File WeaponSystems Units Parts Help

Parts Engineering

Research Part Definitions DB Utilities

Part Similarity Evaluation Method Re-eval Frequency System Action Items

New	Edit		
12-Jul-95		Re-evaluate Unit3	A1020B-PG84B <Eval Code A>
15-Jul-95		Re-evaluate UnitB	AD664TD-UNI/883B <Eval Code A>
2-Aug-95		Re-evaluate UnitB	54F175DMQB <Eval Code S>
2-Aug-95		Re-evaluate UnitB	IDT71256S100DB <Eval Code S>
10-Aug-95		Re-evaluate UnitB	LM185-1 2/883 <Eval Code A>

  
 DMSMS Management System (DMS\*) - User 2

DMS\* Prototype Demonstration

Events Reset Exit

DMSMS Management System (DMS\*) - User 1

File WeaponSystems Units Parts Help

Parts Engineering

Research Part Definitions DB Utilities

New	Edit	Prioritize	
12-Jul-95		Re-evaluate	
12-Jul-95		Re-evaluate	
15-Jul-95		Re-evaluate	
2-Aug-95		Re-evaluate	
2-Aug-95		Re-evaluate	
10-Aug-95		Re-evaluate	

Re-evaluation Frequency (In Months)

A (Acceptable):

S (Suspect):

N (Near Obsolete):

  
 DMSMS Management System (DMS\*) - User 2

**DMS<sup>3</sup> Prototype Demonstration**

Events Reset Exit

**DMSMS Management System (DMS<sup>3</sup>) - User 1**

File WeaponSystems Units Parts Help

**Parts Engineering**

Research Part Definitions **DB Utilities**

New	Edit	Prioritize		
12-Jul-95		Re-evaluat		ams
12-Jul-95		Re-evaluat		Eval Code A)
15-Jul-95		Re-evaluat		<Eval Code A>
2-Aug-95		Re-evaluat		83B <Eval Code A>
2-Aug-95		Re-evaluat		val Code S)
10-Aug-95		Re-evaluat		B <Eval Code S>
				<Eval Code A)

**DB Utilities**

- GIDEP
- FEDLOG
- Tech. Trends Forecast
- IHS
- TacTech
- NSNs
- SMDs
- SCDs
- Manufacturers
- Data/Trend Analysis



DMSMS  
Management  
System (DMS<sup>3</sup>) -  
User 2

**Phase I Prototype Data and Sources**

Data	Source	Commercial/Government
Detailed IHS parts data	IHS	Commercial
TACTech parts descriptions	TACTech	Commercial
SMD data	DESC Bboard	Government
NSN information	FEDLOG	Government
DMS Notices	MOM Bboard	Government
TTF database	MOM TTF	Government
Company Information	DESC Bboard	Government
	FEDLOG	Government

**Phase II Data Required and Possible Sources**

Data	Possible Sources	Commercial/ Government	Load Frequency
Parts data - characteristics and descriptions	IHS PartsMaster	Commercial	Periodic updates
	TACTech	Commercial	Periodic updates
	MOM TAD database	Government	One-time, initial source of some parts data from MTAs already performed.
Weapon System Breakdowns	Weapon Systems File, ASO data	Government	Initial load for each system. Possible periodic updates.
	MOM Database	Government	One-time, initial load for systems currently in the MOM database
	NECAD	Government	One-time, initial load for systems currently in NECAD.
Logistics Information (NSN, etc.)	FEDLOG	Government	Periodic updates.
	IHS Haystack	Commercial	Periodic updates. Reportedly better than FEDLOG.
DMS Notices	MOM obsolescence notices	Government	One-time, initial load for existing notices.
	GIDEP	Government	Frequent (probably daily) updates from files downloaded from GIDEP.
TTF database	MOM TTF database	Government	Initial load. Updated every two years from studies.
SMD Information	DESC Bulletin Board	Government	Periodic updates
	TACTech	Commercial	Periodic updates
SCD Information	some from Logistics Information - NSNs sometimes list SCDs	see Logistics Information above	Periodic updates
	MOM database	Government	One-time, initial load
Solutions/Case data	NECAD	Government	One-time, initial load.
	other database of solutions	Government	One-time, initial load.

Note: Periodic updates would probably occur monthly.