

REPORT DOCUMENTATION PAGE

Form Approved
OMB No. 0704-0188

Public reporting burden for this collection of information is estimated to average 1 hour per response, including the time for reviewing instructions, searching existing data sources, gathering and maintaining the data needed, and completing and reviewing the collection of information. Send comments regarding this burden estimate or any other aspect of this collection of information, including suggestions for reducing this burden, to Washington Headquarters Services, Directorate for Information Operations and Reports, 1215 Jefferson Davis Highway, Suite 1204, Arlington, VA 22202-4302, and to the Office of Management and Budget, Paperwork Reduction Project (0704-0188), Washington, DC 20503.

1. AGENCY USE ONLY (Leave blank)		2. REPORT DATE Jan 94		3. REPORT TYPE AND DATES COVERED Final 1 Nov 92 - 30 Jun 94	
4. TITLE AND SUBTITLE High-Powered CO2 Laser Interactions with Surface and Related Studies				5. FUNDING NUMBERS DAAH04-93-G-0010	
6. AUTHOR(S) Peter A. Franken					
7. PERFORMING ORGANIZATION NAME(S) AND ADDRESS(ES) Univ. of Arizona Tucson, AZ 85721				8. PERFORMING ORGANIZATION REPORT NUMBER	
9. SPONSORING/MONITORING AGENCY NAME(S) AND ADDRESS(ES) U.S. Army Research Office P.O. Box 12211 Research Triangle Park, NC 27709-2211				10. SPONSORING/MONITORING AGENCY REPORT NUMBER ARO 30943.1-EL	
11. SUPPLEMENTARY NOTES The views, opinions and/or findings contained in this report are those of the author(s) and should not be construed as an official Department of the Army position, policy, or decision, unless so designated by other documentation.					
12a. DISTRIBUTION/AVAILABILITY STATEMENT Approved for public release; distribution unlimited.				12b. DISTRIBUTION CODE	
13. ABSTRACT (Maximum 200 words) Research at 5 premier Russian Institutes in Moscow and St. Petersburg have been supported under this program. These efforts include: "High Power Laser Interactions with Surfaces" (Kurchatov Institute, Moscow Region), "Tunable Diode Laser Spectroscopy" (General Physics Institute, Moscow), "Development of New Optical Instrumentation for UV, EUV, X-ray, and Thermal Neutron Radiation" (Lebedev Institute, Moscow), "The Mechanisms of and preliminary experiments for UV and Near X-ray Lasers" (Spectroscopy Institute, Moscow Region), and "SiC Device Research" (Ioffe Institute, St. Petersburg). The best measure of first year progress is the impressive number of publications: 22 papers have been accepted for publication in referred professional journals, 66 articles are currently in preparation and/or submitted for publication, and 71 papers have been read at International Conferences.					
14. SUBJECT TERMS X-ray Lasers, SiC Devices, High Power Laser Interaction, Tunable Diode Lasers, EUV Instrumentation				15. NUMBER OF PAGES	
				16. PRICE CODE	
17. SECURITY CLASSIFICATION OF REPORT UNCLASSIFIED		18. SECURITY CLASSIFICATION OF THIS PAGE UNCLASSIFIED		19. SECURITY CLASSIFICATION OF ABSTRACT UNCLASSIFIED	
20. LIMITATION OF ABSTRACT UL					

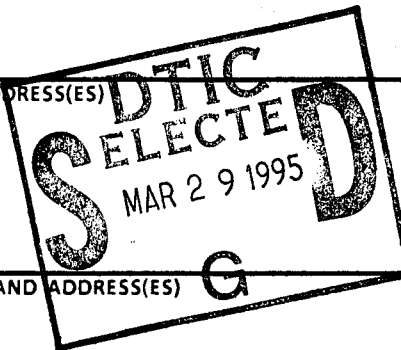

JUN 9 5 1993

ARO 30943.1-EL

**HIGH-POWERED CO₂ LASER
 INTERACTIONS WITH SURFACES
 AND
 RELATED STUDIES**

By:

The Optical Sciences Center
of the University of Arizona

FINAL REPORT

Grant #DAAH04-93-G-0010

Accession For	
NTIS CRA&I	<input checked="" type="checkbox"/>
DTIC TAB	<input type="checkbox"/>
Unannounced	<input type="checkbox"/>
Justification	
By	
Distribution /	
Availability Codes	
Dist	Avail and/or Special
A-1	

19950327 175

Table of Contents:

Chapter 1	Brief History and Summary.....	1
Chapter 2	Reports of the Individual Institutes.....	4
2.1	General Physics Institute.....	4
2.1a	Key Accomplishments.....	4
2.1b	Journal Articles Published.....	5
2.1c	Journal Articles Accepted.....	5
2.1d	Journal Articles Submitted for Publication.....	6
2.1e	Journal Articles Currently in Preparation.....	7
2.1f	Invited Papers Presented at Conferences.....	8
2.1g	Contributed Papers Presented at Conferences.....	8
2.2	Ioffe Physico-Technical Institute.....	9
2.2b	Journal Articles Accepted for Publication.....	23
2.2d	Journal Articles Submitted for Publication.....	32
2.2e	Journal Articles Currently in Preparation.....	37
2.2f	Papers Submitted to International Conferences.....	43
2.3	Kurchatov Institute.....	43
2.3a	Key Accomplishments.....	43
2.3b	Journal Articles Published.....	45
2.3c	Journal Articles Accepted for Publication.....	46
2.3d	Journal Articles Submitted for Publication.....	46
2.3e	Journal Articles Currently in Preparation.....	47
2.4	Lebedev Physical-Technical Institute.....	47
2.4a	Key Accomplishments.....	47
2.4b	Journal Articles Published.....	48
2.4c	Journal Articles Accepted for Publication.....	49
2.4d	Journal Articles Submitted for Publication.....	49
2.4e	Journal Articles Currently in Preparation.....	51
2.4f	Invited Papers Presented at Conferences.....	51
2.4g	Contributed Papers Presented at Conferences.....	52
2.5	Institute of Spectroscopy.....	53
2.5a	Key Accomplishments.....	53
2.5b	Journal Articles Published.....	54
2.5c	Journal Accepted for Publication.....	55
2.5d	Journal Articles Submitted for Publication.....	56
2.5e	Journal Articles Currently in Preparation.....	58
2.5f	Invited Papers Presented at Conferences.....	58
2.5g	Contributed Papers Presented at Conferences.....	58

CHAPTER 1

Brief History. The genesis of this program lay in the Defense Department recognition that there were absolutely first class elements in Russian basic research conducted at many of their premier research institutes. This fact, together with the economic reality of Russian professional salaries being some 50 times less than U.S. counterparts, led to the decision during calendar 1992 to support five specific research programs in Moscow and St. Petersburg, contractually modeled after basic research grants and contracts placed to American universities. Materials, equipment, and operational costs are much the same in Russia as they are in the United States and Europe, so the overall "financial" gain is only about 15 fold over equivalent research being conducted in the United States.

It would have been virtually impossible for any agency within the Department of Defense to directly fund a Russian research institute because the contractual conduit would have been (and probably still would be) through the Russian Academy of Sciences. The ultimate result of this process would be that it would have been fortunate if as much as 10 cents on the dollar were actually deployed by the Russian principle investigators! The "overhead" attached to these funding transfers by the banks, as well as the Academy administration, in series with the Institute front offices themselves, is what accounts for this dreadful loss mechanism.

Accordingly, it was decided that the Defense Department, through the Army Research Office in Raleigh-Durham, would issue a straight-forward grant to the University of Arizona designating Professor Peter Franken as the principle investigator. The University, in turn, would conduct the identified research "off campus" along the established and well audited manner in which off campus research is usually carried out. As examples, we may consider high-energy physicists using accelerator facilities in Geneva, or anthropologists on location in Peru. For these activities the University takes responsibility for salaries, travel, operational expenses on site, etc. In the present situation, with research being conducted in Moscow and St. Petersburg, the University has again been faced with the task of payroll and other "off

campus" expenses, but with somewhat atypical constraints and complications which will be detailed further in this report.

Despite the occasionally bizarre complexities of accomplishing the support of approximately 190 scientists in Russia, this program has been outstandingly successful, as will now be described in the various summaries that follow.

Numerical summary of progress. In the period beginning November, 1992 through September, 1993 approximately 190 FTE (full time equivalent) Russian Scientists and associated staff have been supported. The research results are diverse, of course, and are summarized in the individual institute reports of chapter 2. The overall publication summary for this ten month period has been as follows:

Number of journal articles published:	12
Number of journal articles accepted for publication:	10
Number of journal articles submitted for publication:	27
Number of journal articles currently in preparation:	39
Number of invited papers presented at conferences, largely international:	10
Number of conference contributed papers:	61.

This phenomenal production derives, primarily, from the fact that Russian salaries are much less than their American counterparts, even though operational costs are much the same as in the US. Nevertheless, even with this correction noted, the output has been remarkably high.

Administrative delicacies. Underlying the basic facts of contemporary Russian economics lies the somewhat fundamental fabric of what can be gently described as marginal business practice woven together with corruption. The aphorism "the rich get richer and the poor get poorer" applies to current Russian economics and derives, in large part, from the virtual absence of sensible regulation or controls. The Russian government does not yet understand, seemingly, that "free market economy" has to be exceedingly well (and intelligently) regulated;

it is not sufficient just to be free. Accordingly, the University has had to design quite a variety of novel funding mechanisms as well as management procedures to deal effectively with the challenge of this contract.

One of the most vexatious challenges has been establishing an efficient transfer of money to Moscow and St. Petersburg for the monthly payroll journal of some \$12,500, as well as an equivalent sum for materials and operations. This money is needed directly in the Russian cities (either in dollars or rubles) and there is no simple or standard procedure for accomplishing such transfers. The familiar mechanism of "wire transfers" from U.S. banks through correspondent institutions in Moscow and St. Petersburg results in losses exceeding 30%. These losses arise from a mixture of excessive banking greed as well as governmental taxation at the Russian end of the transfers, but matters may improve in the near future as (hopefully) Western banks might become licensed to conduct operations in Russia itself. At the present time, of course, many Western banks have offices in Russian cities but are not allowed to conduct conventional cash operations.

The best solution to this dilemma has been for Professor Franken and others to "courier" some of the money on their trips to Russia, supplemented by the use of Western Union (at about a 6% loss) as well as special financial transactions that have been possible from time to time. These are consistently and thoroughly documented with the recognition that they constitute atypical although outstandingly cost effective procedures.

As an interesting example, approximately 50 Russian scientists will have had a visit to the U.S. for the primary purpose of technology transfer, via participation in major U.S. based scientific conferences. Round-trip airfares from Moscow to the east coast run about \$600 if purchased on Aeroflot in Moscow but something like \$1500 if purchased from Aeroflot in the U.S.A. ! For most of these trips it has been possible for the Russians to scrape together enough cash to buy their tickets in Moscow and, upon presentation of receipts in the United States to be reimbursed in dollars here. This has permitted a substantial savings in travel costs, and is entirely legal within the Russian regulations that currently exist.

CHAPTER 2

Reports of the Individual Institutes. In the Fall of 1993 Prof. Franken asked each Principle Investigator in Russia to provide a brief "progress report" to be included in the present document. They were asked to merely describe, briefly, the key accomplishments of their program this year. It was emphasized that they should each select material that THEY regarded as important, rather than to anticipate what WE might think was important! In the summaries that follow, the prose of the individual Principal Investigators has been used, with only minor modifications of language made by Professor Franken.

2.1 **The General Physics Institute (Moscow); Alexander Prokhorov, Director and Alexander Nadezhdinskii, Principal Investigator.**

2.1a **Key accomplishments.**

Different physical processes limiting accuracy of tunable diode laser spectroscopy were investigated. Due to these investigations, significant improvement in precision parameters were obtained leading to observation of new physical effects:

- 1) Local line mixing effect in polyatomic molecules spectra causing nonlinear behavior of broadening vs. pressure of resonance structures in polyatomic molecules' spectra at high buffer pressure.
- 2) Quantum behavior of colliding particles was observed originating in a resonance of the broadening cross-section in the region of the adiabaticity parameter being unity.
- 3) First experimental observation of a difference between "hard" and "soft" collisions (molecules' velocity relaxation occur during one collision or diffusion process in velocity space takes place.) Recent results enable us for the first time to determine partial transport cross-sections as a function of quantum numbers of molecular rotational-vibration states. Several applications require such detailed information.

- 4) Simultaneous measurement of trace CO and CO₂ molecules concentration in human breath showed several specific features as important for early medical diagnostics.
- 5) TDL were used to measure rotational-vibrational levels of population in active medium of high power CO₂ laser.
- 6) Diode lasers were developed for the spectral range 1.8 - 3.5 μ , which has previously been a "black hole" for diode lasers. The lasers with wavelength <2.3 μ m can operate near room temperature. At the moment only a group in St. Peterburg is able to do this job. Thus, at the moment, we have an almost exclusive opportunity to perform unique spectroscopic investigations.

2.1b Journal articles published.

1) V.G. Avetisov, A.I. Nadezhdinskii, A.N. Khusnutdinov, P.M. Omarova and M.V. Zyrianov, *Frequency scale precision in diode laser spectroscopy*, published JQSRT, 1993.

Errors in tunable diode laser spectroscopy (TDLS) are discussed. *Proper allowance for error sources may lead to a scale precision of 5-10 cm⁻¹.*

2) V.G. Avetisov, A.I. Nadezhdinskii, A.N. Khusnutdinov, P.M. Omarova and M.V. Zyrianov, *Diode laser spectroscopy of water vapor at 1.8 μ with line profile measurements*. published JMS, v.160, 1993.

A diode laser spectrometer has been used for high accuracy H₂O line profile measurements near 5475 cm⁻¹. Measured line shapes have been least-squares fitted by Voigt profile with a floating Gaussian component. Gaussian component pressure dependence resulting from Dicke narrowing effect is observed. Line intensities, self- and air-induced broadening and shifts of five water vapor lines are presented.

2.1c Journal articles accepted.

1) A. Nadezhdinskii, P. Omarova, M. Zyrianov, *Precision limitations of tunable diode laser spectroscopy*, prepared for publication.

Precise molecular spectra obtained by Tunable Diode Laser Spectrometers were fitted by Voigt profile. All line parameters (transition frequencies, line intensities, Lorentzian

and Gaussian parameters) were obtained from this fitting. Different effects limiting TDLS precision such as laser noise, detector non-ideality, zero absorption and zero transmission levels determination, etc. were considered. Results are presented in analytical form showing error dependence upon various experimental parameters. The results were tested through computer modeling and compared with the obtained experimental results.

2) A. I. Nadezhdinskii, *Spectral lines broadening in polyatomic molecules spectra; Local lines mixing.*

A new approach is proposed to investigate polyatomic molecular spectra, where these spectra are treated as an ensemble of all spectral lines. Statistical parameters of the whole ensemble have to be measured in this approach, giving averaged information about spectral lines distribution function and relaxation matrix. The approach appears to be very powerful, yielding qualitative information even for spectra with strongly overlapping lines. A theoretical model was developed to give physical meaning for measured values. Thus, new information was obtained for polyatomic molecule spectra that could not be investigated previously due to problems of experiment and treating. Some new effects were observed, such as line mixing and resonance behavior of collisional broadening and shifts. Resonance was observed for experimental parameters showing quantum behavior of colliding particles' translation motion. Model was proposed to explain observed results.

2.1d **Journal articles submitted for publication.**

1) S. M Chernin, *New multipass systems in high resolution spectroscopy.*

This brief review deals with various types of new multipass systems developed for urgent high resolution spectroscopic applications at the Institute of Chemical Physics of the Russian Academy of Sciences. Some of them have been widely acknowledged and independently applied in different fields of modern science and technology, i.e. laser technology, metrology, spectral instrument engineering and environment.

2) A. Nadezhdinskii, N. Sobolev and S. Kadner, *Tunable diode laser spectroscopy; New methods and applications.*

The goal of this paper is to present a brief view of recent results obtained in The General Physics Institute of the Russian Academy of Sciences and collaborating organizations. The results are related to limited topics of Tunable Diode Laser Spectroscopy, such as Tunable Diode Laser based systems and their applications. Properties of diode laser (available in Russia) being important for monitoring are discussed. Several systems developed in GPI are considered. Some features enabling us to develop DL based systems under full computer control for long term monitoring are reviewed.

2.1e Journal articles currently in preparation.

1) A. I. Nadezhdinskii, P. M. Omarova, *Precise spectral lineshape measurements.*

Experimental distinctions between "soft" and "hard" model profiles.

2) S. M. Chernin, *New generation of multipass systems.*

3) A. I. Nadezhdinskii, P. M. Omarova, *Precision limitations of spectral lineshape measurements for tunable diode laser spectroscopy.*

4) K. L. Moskalenko, N. V. Sobolev, I. A. Adamovskaya, E. V. Spepanov, A. I. Nadezhdinskii and S. McKenna-Lawlor, *Tunable diode laser application for fully automated absolute measurements of CO and CO₂ concentration in human breath.*

5) K. L. Moskalenko, A. I. Nadezhdinskii and E. V. Spepanov, *Tunable diode laser spectroscopy application for ammonia and methane content measurements in human breath.*

6) M. Spiridonov and D. Toebaert, *Diagnostics of a fast-axial-flow CO₂ laser active medium using a diode laser spectroscopy technique.*

7) A. N. Baranov, T. N. Danilova, O. G. Ershov, A. N. Imenkov, V. V. Sherstnev and Yu. P. Yakovlev, *Long-wavelength InAsSb/InAsSbP lasers for the spectroscopy of methane ($\lambda = 3.2 - 3.4 \mu\text{m}$), Sov. Tech. Phys. Let. 18 (11), nov. 1992, p. 725.*

8) A. N. Baranov, S. Yu Belkin, T. N. Danilova, O. G. Ershov, A. N. Imenkov and Yu. P. Yakovlev, *Generation of coherent radiation at the n-n interface in double heterostructure*

GaInAsSb lasers, Sov. Tech, Phys. Let. 18 (9), Sept. 1992, p. 555.

9) Yu. P. Yakovlev, A. N. Baranov, A. N. Imenkov, A. A. Popov and V. V. Sherstnev, *Tunable IR-diode lasers based on the A3B5 solid solution for the spectral region range 2-4 μ m*.

2.1f Invited papers presented at conferences.

1) A. I. Nadezhdinskii, *Tunable diode laser spectroscopy; New methods and applications*, High Resolution Molecular Spectroscopy Conference, Sept. 1992, Prague.

2) Yu. P. Yakovlev and A. A. Popov, *Recombination processes in long wavelength LED on the base of InGaAsSb ($\lambda = 2.55 \mu\text{m}$, $T = 300\text{K}$)*, International conference on semiconductor Physics, N-Novgorod, Russia, Sept. 1993.

2.1g Contributed papers presented at conferences:

1) B. A. Andreev, S. M. Shapin, *High-resolution spectra of pure volatile inorganic hydrides in the middle infrared range*.

2) V. G. Avetisov, A. I. Nadezhdinskii, A. N. Khusnutdinov, P. M. Omarova and M. V. Zyrianov, *Diode laser spectroscopy of water vapor at 1.8 μ m; Line profile measurements*.

3) P. M. Omarova, *Rapid precise spectral line fitting with four parameter Voight Function*.

4) A. I. Nadezhdinskii and P. Omarova. *"Soft" and "hard" collision models. Experimental observation of differences in spectral line shape*.

5) A. I. Nadezhdinskii. *New approach of polyatomic molecule spectra treatment. Observation of quantum behavior of colliding particles*.

6) G. A. Makssimov, V. A. Khorshev and S. M. Shapin. *Determination of water content in high-purity volatile substances by the method of laser absorption IR-spectroscopy*.

7) K. L. Moskalenko, A. I. Kuznetsov, A. I. Nadezhdinskii, N. V. Sobolev, E. V. Stepanov and S. McKenna-Lawlor. *Application of tunable diode lasers to fully automated monitoring of concentrations of Co and CO₂ in human breath*.

8) K. L. Moskalenko, A. I. Nadezhdinskii, E. V. Stepanov and I. A. Adamovskaya. *Tunable*

diode laser spectroscopy application for absolute measurements of CO and CO₂ concentrations in human breath.

9) K. L. Moskalenko, A. I. Nadezhdinskii and E. V. Stepanov. *Tunable diode laser system for ammonia content measurements in human breath.*

10) Yu. P. Yakovlev, A. N. Baranov, A. N. Imenkov, A. A. Popov and V. V. Sherstnev. *New semiconductor lasers based on the A3B5 solid solution for the spectral range 2-3mm.*

11) P. V. Zyrianov, N. I. Sobolev and A. I. Kuznetsov. *Control and data acquisition system for diode laser based analytical applications.*

12) A. I. Nadezhdinskii and P. Omarova, *Precision limitations of tunable diode laser spectroscopy.*

13) V. G. Avetisov, A. I. Nadezhdinskii, A. N. Khusnutdinov and M. V. Zyrianov. *Frequency scale precision in diode laser spectroscopy.*

October 11-15, 1993, Optical Instrumentation and Atmospheric Measurements, Atlanta, Georgia, USA

1) S. I. Chernin (Institute of Chemical Physics, Russian Ac. Sc., Moscow) - *New generation of multipass optical cells.*

2) Yury P. Yakovlev (Physics-Technical Institute of Russian Ac. Sc., St. Petersburg) *Tunable IR-diode lasers for spectral range 2-4 microns and their applications.*

3) A. Nadezhdinskii, *Tunable diode laser spectroscopy. New methods and applications.*

2.2 The Ioffe Physico-Technical Institute (St. Petersburg); Zhores Alferov, Director and Valentin Chelnokov, Principal Investigator.

Several months ago Prof. Franken wrote to each of the principal investigators and requested a brief summary of important results to date, as well as material he could use in the 1994 proposal. The summaries presented here in chapter 2 have been, as noted, reproduced with slight editing by Professor Franken for purposes of clarity.

However, the response from Professor Chelnokov has a most unusual quality to it, and, accordingly, is reproduced exactly as it was received. The fact that the response of the Ioffe has been much more detailed than that from the other four Institutes does not, in our opinion, reflect at all adversely on the other four. Instead, it illustrates a different and interesting form of response; a kind of translation of what Professor Chelnokov and his colleagues believe an American progress report should be!

Introduction

When in 1992 we wrote the proposal for this Project we had absolutely no experience in writing such documents though were familiar with instructions on drawing up proposals of this kind and seen prepared proposals.

The very volume of instructions and finished proposals (25–30 typewritten pages), a multitude of sections and subsections and other requirements seemed terrific to us. Not knowing what specific problems you were going to put before us, we prepared a brief proposal in which we attempted, in a very concise manner, to present all those things which we were ready and willing to do in the field of SiC research and development. We believed that then you would choose one or more among the proposed problems and we would draw up on these problems a detailed proposal following those complicated instructions.

The fact that this brief proposal has been accepted as it was we welcomed as a great and pleasant surprise because we were thus spared a lot of unwonted work of drawing up the proposal.

On the other hand, this made us feel uneasy because our brief proposal contained many different and complex problems.

So, in the term of one year we had to implement for you a tremendous volume of work with an additional complication of not having any previous experience of collaboration with people in the United States. How we succeeded in this task you will see from the report below.

1. Budget of the Project

- (a) USD 35,000 as salaries (USD 2,500 a month, 14 months);
- (b) USD 1,500 for operations and supplies;
- (c) USD 14,000 for equipment (computers and other technical means);
- (d) USD 6,000 for travels;
- (e) USD 21,000 as overheads for the Ioffe.

The total amount will be USD 77,500. In an event of any changes in the work on this grant the budget items (a), (b) and (d) may be altered by agreement with the University in such a way that the total expenses will be unchanged.

These minor alterations have been approved by Prof. P. Franken. So, the total sum spent by the Laboratory proper on the work on the Project amounts to approximately $77,500 - 21,000 = 56,500 + 700$ or about USD 57,000.

2. Number of personnel and the amount of work done

Executors of the work were mainly of the Laboratory personnel. However, for some special tasks research workers from other laboratories of the Institute were enlisted.

The work shall be completed by the end of 1993 (14 months, Nov.92–Dec.93 or approximately 350 days, on the average, 25 working days a month because the work took more than 8 hours a day and so forth).

Till now (11.92–09.93), there lapsed 11 month, i.e., 275 days. The average monthly number of workers was 34.7. Labor expenditure is 9,550 man days, USD 27,271 have been paid in wages and salaries.

Thus, the cost of every working day of the entire team was approx. USD 98 and the cost of every man-day approx. USD 2.63.

The average monthly salary was USD 66–70.

The total number of those engaged in the work was 50 persons.

In the remaining three months of this year the above figures will change insignificantly.

Research associates, engineers and technicians took part in the work. As seen from the complete list of personnel (see Appendix 1), research associates having various academic degrees numbered 40, engineers 3 and technicians 7 persons.

The main essential "product" of the work on the project are papers and conference reports.

Today we have submitted 39 papers for publication in the ICSCRM-93 Proceedings. The Proceedings will be published as a book by IOP Publishing Ltd. (Bristol, England). Besides, 17 papers have been submitted for publication in those Russian journals which AIP translates into English and 25 papers are now in preparation. Three other papers have been accepted for presentation at the E-MRS-93 meeting, at the European Conference on Diamond, Diamonds-like and Related Materials (DDRM-93, Albufeira, Portugal), and at the International Semiconductor Device Research Symposium-93 (Charlottesville, USA).

Appendix 2 contains the list of publications.

Besides, the work on the project resulted in the following engineering and technological developments.

- A CVD installation for producing epitaxial SiC structures has been designed and constructed (see Photograph 1).
 - A technological process of producing epitaxial n-layers of SiC using this installation has been developed.
 - A prototype installation for producing epitaxial SiC layers by sublimation method using electron beam heating (see Photograph 2).
 - A technological process of producing epitaxial layers of SiC with this installation was tried out.
 - An installation has been designed and constructed for producing layers of silicon oxide, silicon nitride, silicon oxynitride, amorphous and modified nitrides of aluminum and, possibly, gallium by the method of magnetron sputtering with the use of plasmochemical reactions (MAGD—magnetron-assisted gas decomposition) (see Photograph 3).
 - A technological process for producing the above epitaxial layers (with an exception of gallium nitride) with the MAGD installation was tried out.
 - An installation has been designed and constructed for producing by plasma-assisted CVD (plasma-assisted CVD) of the same layers as those produced with the MAGD installation (excepting nitrides) (see Photograph 4).
 - A technological process for producing epitaxial layers with the use of the PACVD installation has been tried out.
 - An installation has been designed and constructed for modifying amorphous, polycrystalline and monocrystalline SiC by the method of anneal in nascent plasma of hydrogen and helium produced by RF-discharge (13.56 MHz) (see Photograph 5).
 - A technological process of modifying SiC with this installation was tried out.
- A more detailed description of designs of the installations and of some technological processes is given below.

3. Areas of research and development work on the Project

3.1. Research and development in the field of technology of SiC and related materials

This field of research covers the development of such technological processes as the growth of bulk SiC single crystals of 6H and 4H polytypes, growth of epitaxial layers of amorphous, polycrystalline and monocrystalline SiC of 6H, 4H and 3C polytypes having different properties, modifying the properties of these layers through different treatments as well as the development of methods of forming multilayer epitaxial structures for use in various SiC devices. Among these methods are metallization of the structures (application of various kinds of contacts), structure etching, surface passivation, protection of the periphery of epitaxial structures and other methods used in fabrication of SiC devices. As substrates, 6H-SiC wafers produced by Lely method in Russia a few years back as well as 4H-SiC wafers produced lately by modified Lely method (also in Russia) were used.

In all, 31 publication deals with this field of research (15 reports and 16 papers, see the list in Appendix 2).

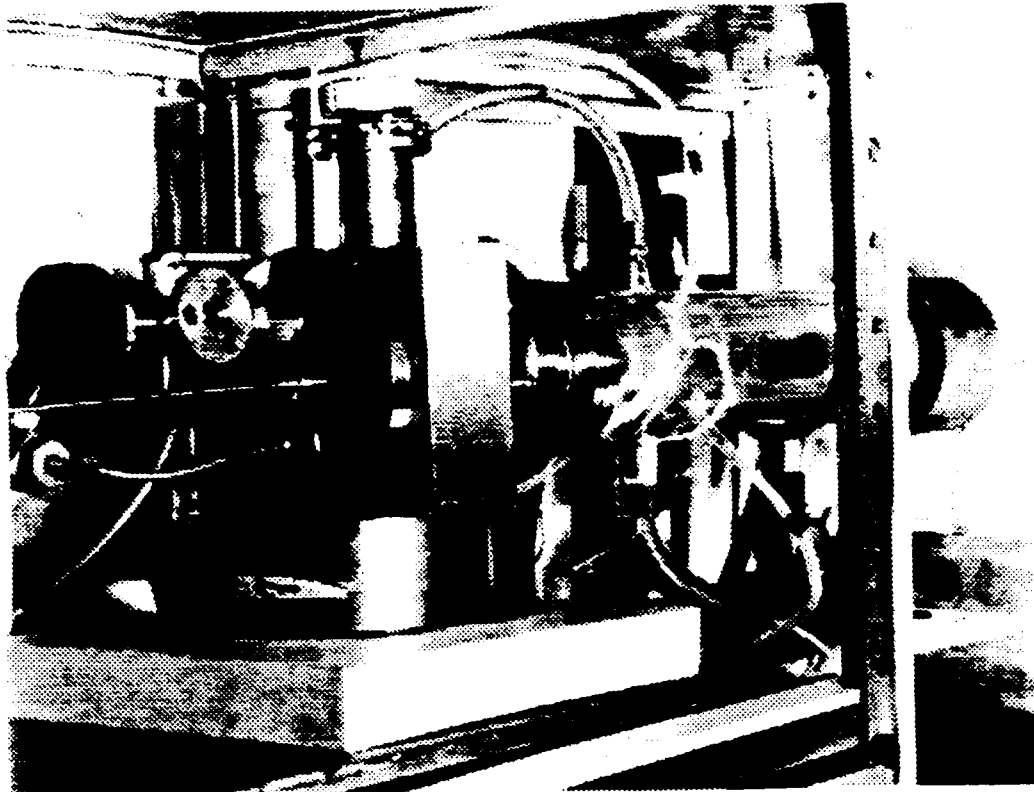

Photograph 1.
An installation for growing epitaxial SiC layers by CVD

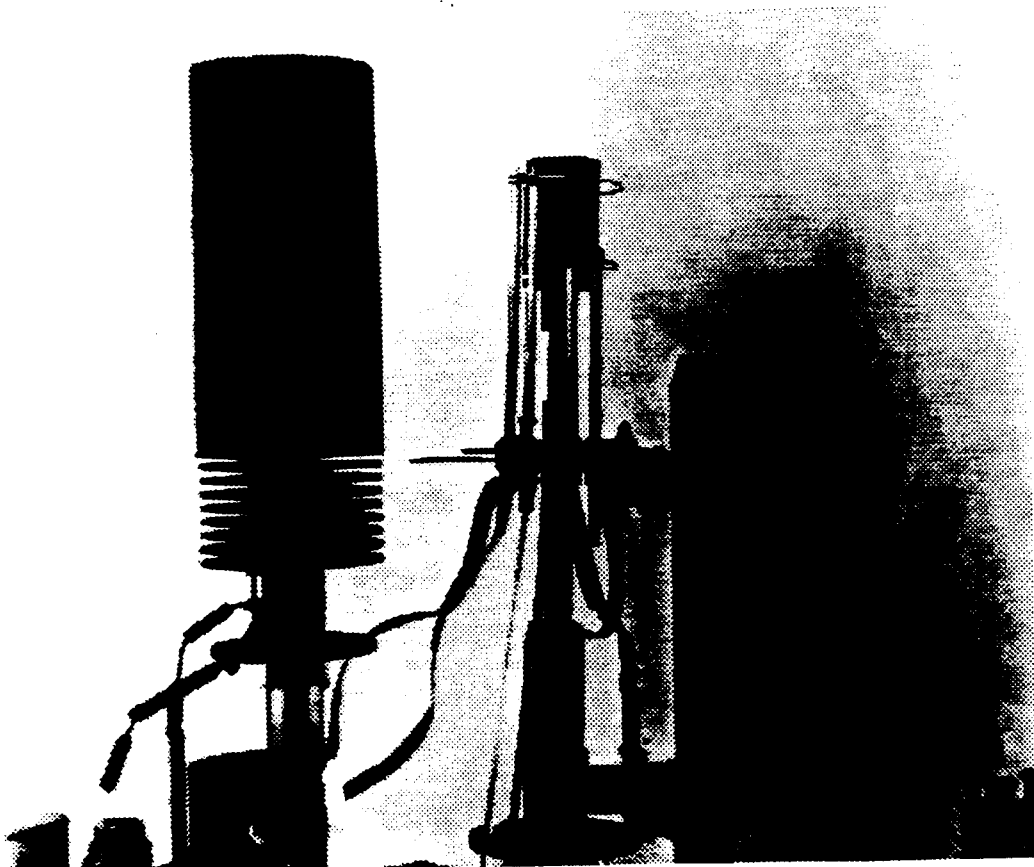

Photograph 2.
An installation for growing epitaxial SiC layers by sublimation with electron heated cell



Photograph 3.
An installation
for magnetron-assisted
gas decomposition

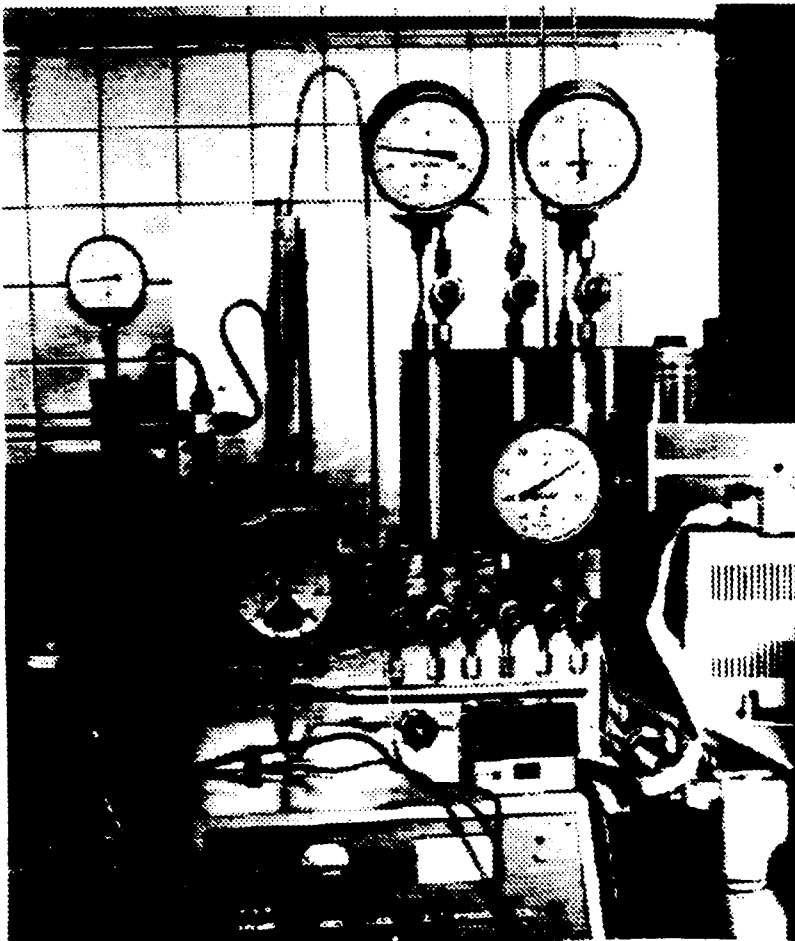

Photograph 4.
An installation
for plasma assisted CVD

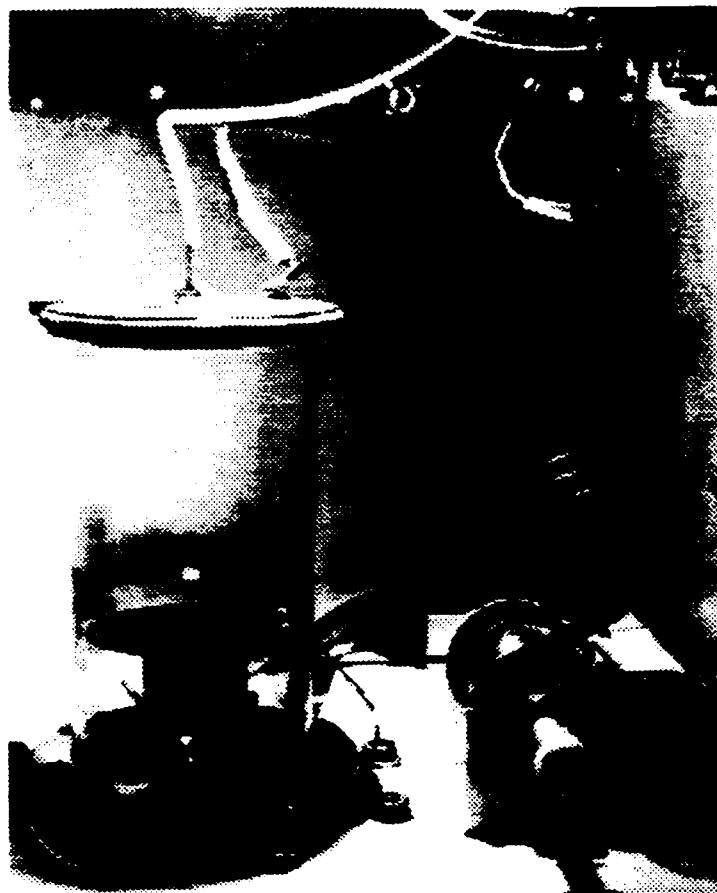

Photograph 5.
An installation for annealing SiC films in nascent plasma
of hydrogen and helium

3.1.1. Sublimation growth of SiC

The major method of growing epitaxial structures in this Laboratory is the original sublimation method developed by us more than 10 years back (patents have been obtained).

The current state and some development prospects for this method are outlined in Refs. 1.1, 1.2.

Most of the epitaxial SiC structures investigated under this project were produced by sublimation method.

In the Laboratory, there are three installations for sublimation growth with induction heating, which are capable of yielding epitaxial layers of n- and p-type of a thickness 1–10 μm in the concentration range 10^{16} – 10^{18} cm^{-3} having rather good quality. However, today we are not satisfied both with the layer parameters such as concentration range, structural characteristics, lifetimes of minority carriers and others and with the production rate of the installation.

Therefore, to further improve this method the use of electron beam heating was suggested [1.3] instead of induction RF-heating. A prototype installation has been constructed (see Photograph 2) and the technological process of growing epitaxial layers tested. The results demonstrate feasibility of growing n- and p-type SiC layers using this method of heating.

However, we did not have enough time and resources in order to construct an installation of high enough perfection, which would have produced higher vacuum (10^{-8} Torr and higher) and had several positions for wafers. These two conditions, as shown in our studies, should ensure high layer quality and high production rate.

Growth of bulk SiC single crystals in our group (Ioffe Institute) was made possible only since the end of 1992 when the financial support in terms of this project was made available to us.

For the crystal growth two or three sublimation installations with resistance or induction heating were used. In our opinion, in this short period rather good results have been achieved, viz., bulk crystals up to 1 inch in diameter have been obtained of 6H and, more important, 4H prototypes, the latter being an ideal material for high-frequency and high-power applications.

Deployment of the work along these lines on a larger scale is restrained by the shortage of some types of equipment, in particular, for cutting and lapping of wafers, as well as by the high costs of operating the equipment and high cost of some materials (for example, graphite).

3.1.2. Ion implantation and some other methods

More than a decade lapsed since the ion implantation method of producing pn junctions has been developed in our laboratory. First diodes and other devices with pn junctions were formed using ion implantation. In the course of this project, this method was further improved and studied, the results obtained have been reported in Refs. 1.14, 1.15.

Also, work was continued on the growth of epitaxial structures using the method of container-free liquid-phase epitaxy developed in our laboratory about ten years ago.

Some results of studies of the samples produced with this method are presented below in Section 3.2.

Regrettably, the work on growing bulk SiC crystals from liquid phase, as suggested in our proposal, could not be done for a number of reasons, one of these being the lack of resources.

Still, 6H-SiC layers have been obtained of a thickness up to 1 mm. The layers were found to be monocrystalline, however their quality was rather poor, inclusions of other polytypes occurred.

In the framework of the project, work on MBE was continued and focused on modification and adjustment of the installation constructed in our laboratory earlier. First results of this work have been published [1.12].

3.1.3. CVD-technology

CVD-technology is at present the most reliably controlled way of growing epitaxial layers having specified properties. So, for instance, there are reports on CVD-growth of epitaxial SiC layers with a doping level of 10^{14} – 10^{19} cm⁻³.

There is known quite a number of versions of the epitaxy from the gas phase differing both in gas mixture composition and temperatures of epitaxy.

The most widely used temperature range for the growth of epitaxial layers was 1250–1350 °C or higher. Therefore, a task was undertaken to design and construct an installation that would have been sufficiently versatile and afforded a possibility of choosing an optimum regime of epitaxy.

Fig.1 shows a schematic drawing of the installation (see also Photograph 1).

The installation comprises a water-cooled reactor with induction heating in a wide temperature range (1200–1650 °C) and a gas unit which can provide dosage of a number of gas mixtures:

- (a) silane-propane,
- (b) methyltrichloride-silane,
- (c) methane-tetrachloride.

As a material of the inner rigging of the quartz reactor (screens, heater) graphite of MPG-6 grade was used. We have also made the rigging of other thermally stable carbon-containing materials (pirocarbon and fiber glass carbon). All inlets and outlets are arranged on one side for convenient dismantling of the inductor without breaking the vacuum inside the reactor. Design of the reactor flange permits loading and withdrawing of samples via the docking chamber to be done without subjecting the inner rigging to a contact with an environment. The reactor has a blown-through optical window through which the temperature control by means of an optical pirometer can be carried out for a long operation term.

Diameter of SiC substrate that can be handled in this installation is about 1 inch and the growth temperature of epilayers is high enough to permit growth of 4H-SiC layers.

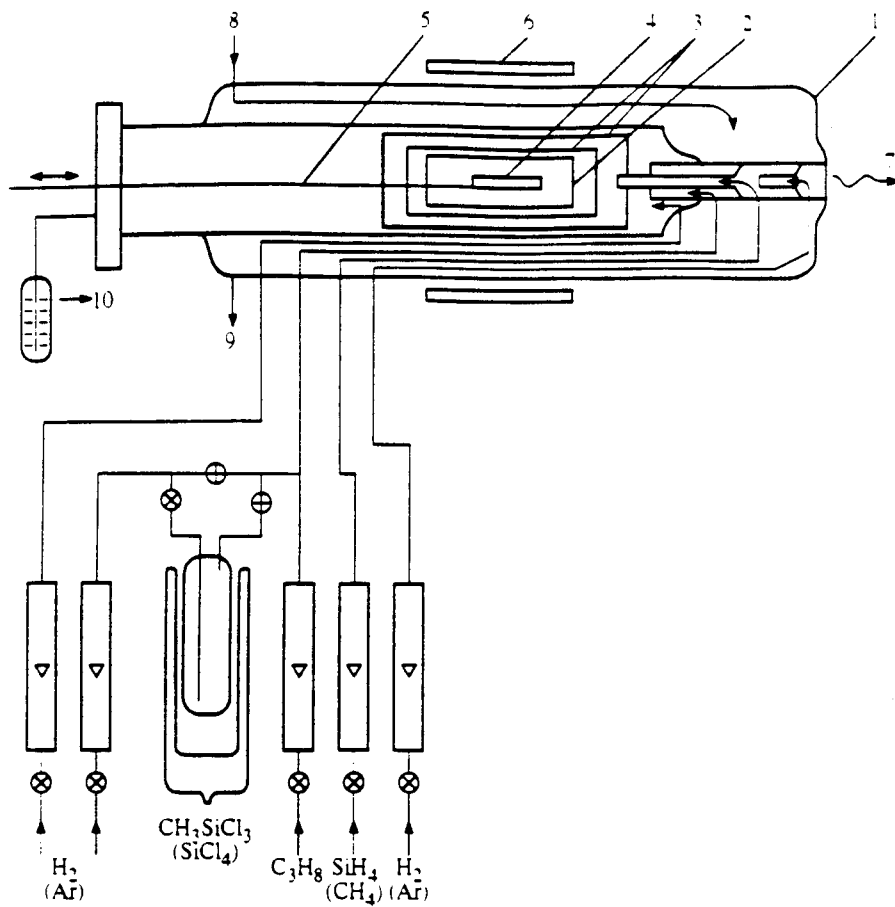

Figure 1.
Schematic diagram of an installation for CVD-epitaxy.

- 1—reactor with water-cooled jacket.
- 2—heater.
- 3—screens.
- 4—substrate.
- 5—rod.
- 6—inductor.
- 7—optical window.
- 8,9—water inlet and outlet.
- 10—outlet for gas mixture

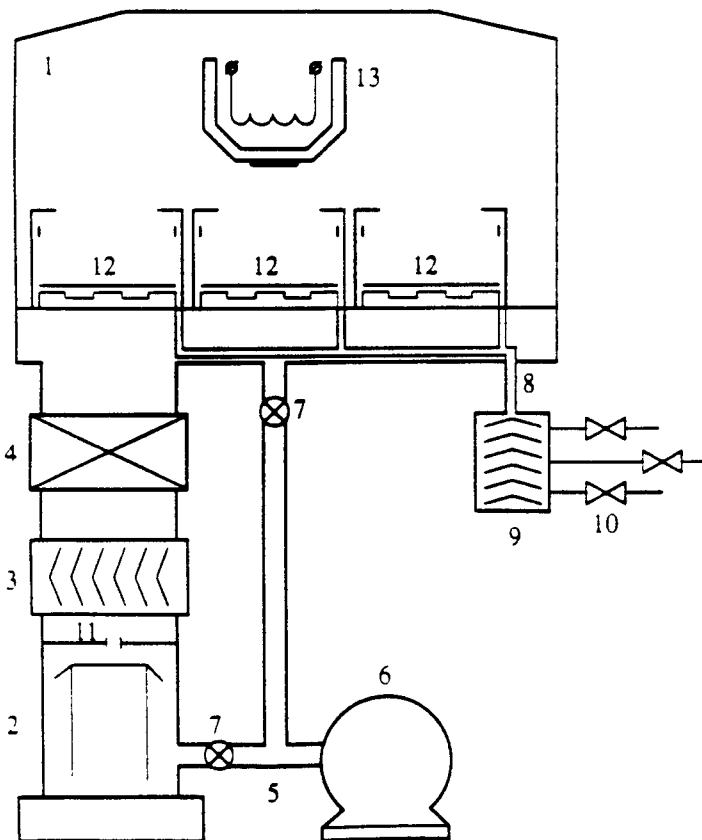

Figure 2.
1—vacuum chamber, 2—diffusion pump, 3—liquid-nitrogen trap, 4—valve, 5—fore-pump duct, 6—fore pump, 7. fore-pump valve, 8. gas supply tube, 9—mixing chamber, 10—precision valves, 11—throttle, 12—magnetron 13—wafer holder with heater.

At present an adjustment work on the installation and the technological process is underway. With the use of conventional CVD installations research was carried out on the growth of 3C-SiC on silicon substrates. The results of this research have been published (see, for example, [1.6, 1.10]). Another direction of research on the processes of relatively low-temperature CVD technology is the growth of aluminum nitride layers and SiC-AlN solid solutions. The results of this studies have been reported in Ref. 1.4, 1.5.

3.1.4. The technology using plasmochemical reactions

As mentioned above, three installations are related to this group of technologies (see Photographs 3, 4 and 5).

These installations (and, consequently, this group of technologies) have an advantage of relative simplicity and provide a possibility of obtaining layers of practically any area on substrates of arbitrary configuration using rather low process temperatures.

At the same time, this group of technologies is capable both of producing layers of corresponding wide band gap materials and dielectrics and of modifying their properties.

Below we give a description of these installations.

An installation for producing SiC and related materials by the method of magnetron-assisted gas decomposition (MAGD).

MAGD installation is based on VUP-5 commercial product in which residual pressures lower than 1.3×10^{-4} Pa (1.0×10^{-6} Torr) can be obtained.

The vacuum chamber (see Fig. 2) houses up to three planar magnetron systems of original design, wafer holder with heater and a wafer holder positioning gear. The use of three magnetron systems makes possible deposition of multilayer coats in one vacuum cycle. A system of gas feed which introduces various gas mixtures directly into the discharge chamber and the possibility of controlling the sputtering power by varying the magnetic field strength and voltage at anodes of the magnetrons (design of the unit is shown in Fig. 3) allow the composition of grown layers to be varied in a wide range. So, this technique is in fact a combination of magnetron sputtering proper and plasmochemical deposition. Effective control of the film characteristics is provided by a possibility of varying the substrate bias potential and of controlling the substrate temperature over a wide range (0–1200 °C).

The magnetron of this design (see Fig. 3) permits operation at a low discharge power and growth at low rates which is especially important low temperature epitaxy.

Cylindrical electromagnet (2) serves simultaneously as the anode of the magnetron (1). The presence of the closed magnetic field (4) near the surface of the target (5) serves to localize plasma in the immediate vicinity of the target. The magnitude of the magnetic field, which is chosen taking into

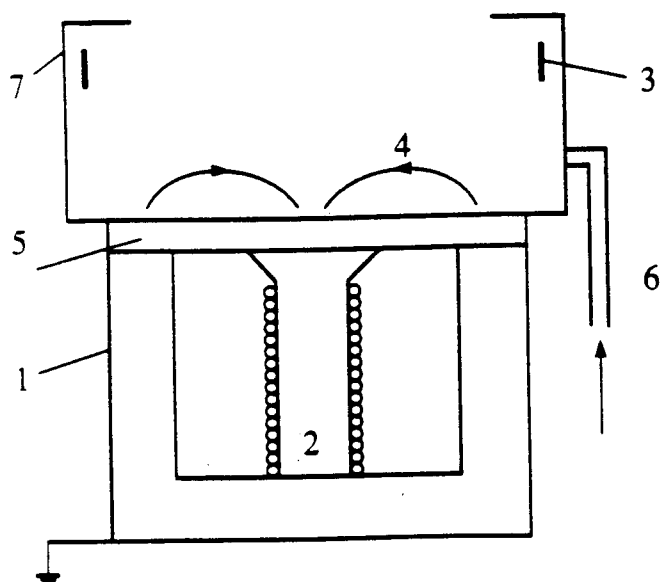

Figure 3.
1—cathode of the magnetron, 2—cylindrical electromagnet, 3—anode, 4—magnetic flux lines, 5—sputtered target, 6—gas duct

account sputtering conditions, can be varied in the range from 0–100 mT by varying the current in the winding of the electromagnet. The cathode of the magnetron is surrounded by a cylindrical anode (3). The voltage applied to the anode (300–500 V) determines the discharge current (15–40 mA). Mixtures of carrier gases via gas duct (6) are fed directly into the discharge chamber (7).

The results of these investigations can be found, for example, in Refs. 1.7 and 1.8.

Installation for producing SiC and related materials by plasma-assisted CVD (PACVD)

A technological installation for preparation of films of amorphous silicon carbide and of other materials is based on VUP-5 commercial installation of which the below-cover unit has been adapted for capacitative RF-discharge and comprises:

1. A unit for film growth:
2. An RF-generator with operating frequency 40 MHz and maximum output power 30 W;
3. A gas distributing system for preparing mixtures of gases of specified composition, feeding these gases into the reaction chamber, measuring the pressure of the gas mixture in the course of the process and for control and stabilization of the gas flow rate through the reaction chamber.

Schematic drawing of the below-cover unit is shown in Fig. 4.

A distinctive feature of the design is the use of a reactor with quasi-sealed volume: the space between the RF- and grounded electrodes of the reactor is encompassed by a cylinder of vitreous silica glass.

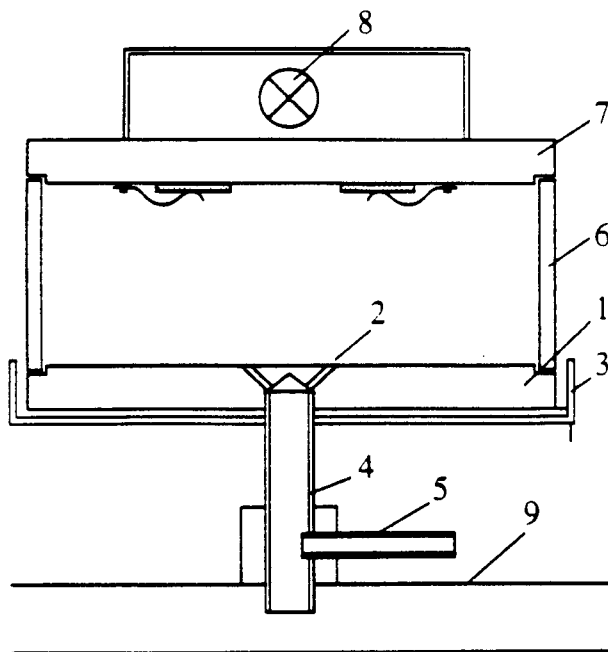

Figure 4.

Schematic drawing of the plasma-assisted CVD below-cover module. 1—RF electrode, 2—sputtering unit, 3—screen, 4—insulating support of the chamber, 5—gas inlet, 6—quartz cylinder, 7—upper electrode, 8—heater, 9—foundation of the vacuum chamber.

Ends of the cylinder are closely fitted to the surfaces of the electrodes. The gas mixture is fed through a special distributing system on the lower RF-electrode. This system maintains a positive pressure relative to the volume under the cover. This facilitates initiation of the gas discharge inside the reactor and serves to localize the gas discharge, to reduce the gas mixture consumption, to lower contamination of the growing film with uncontrollable impurities from the walls of the vacuum system of the installation. Both electrodes of the reactor are made of an Al alloy and polished. The diameter of the electrodes is 120 mm. The RF electrode is located in the bottom part and screened. The separation between electrodes is 30 mm. Substrates for sputtering onto are positioned on the upper grounded electrode. Heating of the upper electrode and substrates is done using a screened quartz lamp of 300 W power. The temperature of the substrates is controlled during the process with a copper-constantan thermocouple and maintained constant. For preparation of gas mixtures of the required composition a preliminary mixing of gases in a mixing chamber (7) is used. The specified mixture composition is achieved by letting in the components until corresponding pressures are reached, the process being controlled by pressure gauge. The gases used are 25%SiH₄ + Ar, 12%CH₄ + Ar, Ar and H₂.

Technological parameters of the sputtering process:

1. Substrate temperature 250 °C;
2. Specific RF-power 0.1 W/cm²;
3. Gas mixture flow rate 0.2 l/h;
4. Fore-vacuum 10⁻⁶ Torr; operating vacuum 5×10⁻² Torr.

Installation for modifying SiC

The technological installation for annealing the films in a hydrogen and helium RF-plasma is similar in its design to that for PACVD but simplified somewhat. The gas system is designed only for hydrogen and helium. The electrode separation is 120 mm. Samples are mounted on a special well-screened high-temperature heater.

Technological parameters of the process of such anneal:

1. Substrate temperature 100–1200 °C;
2. Specific discharge power 0.1–10 W/cm²;
3. Operating vacuum 1×10⁻² Torr.

Some results of these studies can be found, for example, in Refs. 1.11, 1.13.

Special mention should be made of a very interesting work [1.13] on modification of near-surface layers of monocrystalline SiC by annealing in hydrogen or helium plasma. As a result of such anneal, the resistivity of the thin (1–2 μm) near-surface layer is increased by a few orders.

Such technology can, possibly, open new prospects for the silicon carbide electronics, both in preparation of insulating layers and in protection of the periphery of devices with pn junctions.

3.2. Research in the field of structural properties of SiC and related materials

This part of the project covers research on techniques and fundamental properties of crystalline and amorphous SiC and related materials, as well as properties of epilayers and epistuctures grown with the use of technologies described in Section 3.1. Various latest techniques were applied in studies of electrical, optical and structural properties of those objects which were produced in the course of the present project. It should be noted that in every work several techniques were used as a rule. Therefore, it is difficult to group these works on the basis of techniques used. Besides, studies of properties of SiC and related materials (especially, their structural properties) have been discussed in publications referred to in Sections 3.1 and 3.2. In all, this group of publications numbers 35 works (see the list of publications in Appendix 2). These include 16 reports and 19 papers. Among publications dealing predominantly with electrical measurements the following may be mentioned.

Ref. 2.24 deals with a new technique for investigation of deep levels in SiC, and in Refs. 2.5 and 2.6 data can be found on DLTS studies of deep levels responsible for diminution of the diffusion length in SiC. Refs. 2.4 and 2.8 are a continuation of the study of a relation between the diffusion length (lifetime) and recombination parameters, on the one hand, and different technological methods, on the other hand. These studies are very important as leading to a solution of the problem of fabricating high-performance bipolar devices, on the one hand, and, on the other hand, as providing criteria of the perfection of technological processes.

Ref. 2.2 deals with junction breakdown, which is a very important problem for development of high power SiC devices. Refs. 2.1, 2.12 and 2.13 deal with optical properties of SiC. The study was carried out on epistuctures prepared by liquid-phase epitaxy and ion implantation.

Of special interest is Ref. 2.7 where the effect of neutron irradiation on parameters of current-voltage characteristics of pn structures were studied. It is known that one advantage of SiC devices is their high resistance to irradiation as compared, for example, with silicon devices. This paper, on the one hand, confirms this fact and, on the other hand, describes those properties of SiC pn structures which make SiC diodes radiation-hard.

Ultimately, a group of papers, in particular, Refs. 2.9, 2.11 and 2.14 deals with investigations of

epilayers and epistructures prepared by technologies using plasmochemical reactions (Section 3.1.4). Our analysis of these works shows that these technologies can be instrumental in further advance of both fundamental research on SiC and related materials and of applications of these materials.

3.3. Research in the field of development of SiC devices

These investigations deal with theoretical modeling and realization of various SiC devices whose prototypes have been made with the use of technologies and investigation results presented in Sections 3.1 and 3.2.

Here we have 18 publications (see the list of publications in Appendix 2), namely, 11 papers and 7 reports.

All these development works present a considerable advancement in the field of silicon carbide electronics.

Now we find it difficult to indicate the most important developments, however a mention should be made, for example, of such device as a green LED having record-high efficiency, 4H-SiC JFET and 4H-SiC MOS-capacity parameters of which are also record-high in some respects and 6H-SiC JFET with low cut-off voltage.

Very interesting is the development of a SiC varactor operating at frequencies 100–200 GHz.

A mention should be made also of the development of a SiC diode [3.16], the most powerful at the present time.

4. Summary of the Project

In the course of the first year of the work on the Project research was carried out on all the items cited in Articles 2 (Objective) and 3 (Approach) of the Project, the results confirming the preliminary ones as depicted in item 3.3 of the Project.

- In particular, using sublimation method the first in Russia SiC single crystals of 6H and, more important, 4H polytypes 1 inch in diameter have been grown (items 2.1 and 3.1.1). With further improvement of the technique crystals of larger diameter and higher quality can be obtained.
- There have been obtained first thick (up to 1 mm) 6H-SiC layers grown by container-free liquid-phase epitaxy from silicon melt (items 2.1, 3.2.1 and 3.2.3).
- sublimation technique of growing epistructures has been further advanced; technologies have been developed and 6H and 4H-SiC epilayer of various quality produced (items 2.2 and 3.2.1).
- A unique CVD-apparatus has been constructed for the growth at temperatures 1250–1650 °C of epilayers of various SiC polytypes (6H and 4H) on substrates 1 inch in diameter (item 2.2).
- Work was continued on growing SiC-AlN layers (item 2.2).
- Apparatus for plasma-assisted CVD has been constructed and first results on the growth of SiC epilayers obtained (item 3.2.2).
- A prototype installation has been made for growing SiC epilayers with the use of electron beam heating and first SiC epilayers obtained (item 3.2.1).

Besides, the scope of the work on the Project was expanded to cover amorphous SiC and SiC modified into polycrystalline or, possibly, monocrystalline form. Some steps undertaken in this direction are outlined below.

- An installation has been constructed for producing layers of silicon oxide, silicon nitride, silicon oxynitride, amorphous and modified silicon carbide and aluminum nitride by magnetron sputtering with the use of plasmochemical reactions (MAGT, magnetron-assisted gas decomposition).
 - An installation has been constructed for modifying amorphous and polycrystalline SiC by the method of annealing in atomic hydrogen and helium plasma produced by RF discharge.
- The epilayers and epistructures produced by the above methods were examined and characterized using different methods, in particular, those described in Article 1 of the Project.

With the use of all the above technological methods and investigation results on the obtained epilayers and epistructures prototype devices have been developed such as a power diode for forward current of

1 A. low punch-voltage JFET in 6H-SiC, JFET in 4H-SiC, high-efficiency ion-implanted 6H-SiC green LED, SiC varactor operating at a frequency of 150 GHz, SiC LED modules, UV detector based on alpha-SiC:H films, ferroelectric memory cells based on SiC MOS-capacity, SiC thyristor (see item 2.3 and the end of item 3.3 of the Project).

Nearly all the results of the research and development work have been presented in more than 80 publications (including conference reports), a list of these is given in Appendix 2 to this report.

From the above said it follows that in the first year of the Project an advance has been made, to a various extent, on all the items of the Project and, in addition, a considerable volume of work has been done outside the scope of the Project.

In our opinion, a significant advance has been made in the field of electronics based on SiC and related materials.

We ask you to consider a possibility of financing the second year of work on the original Project and of including in the Project additional objects of research, namely, other wide band gap semiconductors, such as amorphous and modified SiC, aluminum and gallium nitrides and, if possible, diamond-like films.

A brief proposal for research along these lines is submitted (see Appendix 4).

5. Conclusions and suggestions

If it is accepted that 1993 is phase I of the work on the Project then, relying on the foregoing, we may conclude, as already done above, that phase I has been successfully completed.

On these grounds, we ask you to consider a possibility of financing to be continued into the second phase of the Project in an amount which you will be able to appropriate for this purpose.

At the same time, judging by the results of work on phase I of the Project, it appears necessary to make some amendments to the Project. These amendments are necessitated by a number of both objective and subjective reasons that could not be taken into account when the original Project was being drawn up in 1992. First, in 1992 we could not envisage a possibility of the fantastic inflation which set on early in 1992 and continues unabated. Therefore, some directions of research that have been written down in the Project in 1992 could not be carried out on a sufficient scale in the course of the work on the Project in 1993 (for example, development of the technology for growing SiC single crystals from melt).

Some directions of research (for example, development of the technology of growing SiC-AlN solid solutions) turned out to be more labor-consuming and their end results more distant than we assumed, though results of the work done along these lines in 1993 suggest that their continuation is worthwhile.

On the other hand, as noted above, we widened the scope of work on the Project and undertook studies not included in the original proposal because we saw that this group of technologies can be very important for the project on SiC and related materials.

Therefore, taking into account our experience of collaboration with you in 1993 we ask you to consider a possibility of financing phase II of the Project in 1994 according to amended proposal submitted below in Appendix 4 to this report.

We hope very much that you will accept our proposals.

2.2b **Journal articles accepted for publication.**

1) A.Yu Maksimov, A.A. Maltsev and N. K. Yushin, ICSCRM-93, *Growth of silicon carbide rectangular boules of one inch dimension.*

This work deals with the growth of the rectangular silicon carbide single crystal boules of 6H and 4H polytypes by sublimation vapor transport method. New approach to the large dimension single crystal boule growth has been suggested. The SiC boules of 3030 mm dimension and 18 - 22 mm height with polytype homogeneity 86% for 4H 93% for 6H-SiC were obtained. The results of measurements some parameters of the plane wafers and ones with epitaxial layers are given.

2) M. M. Anikin, A. L. Syrkin and V. E. Chelnokov, ICSCRM-93, *Sublimation epitaxy of SiC: Development paths and an outlook for the future.*

Main results and potential means of sublimation epitaxy in SiC are observed. Possible ways of development of this technology are discussed.

3) M.M. Anikin, A.A. Lebedev, M.G. Rastegaeva, A.M. Strel'chuk, A.L. Syrkin and V.E. Chelnokov, *Epitaxial layers of n- and p- type 6H-SiC grown by sublimation "sandwich" method in an Electron Heated Cell.*

Main results and potential means of sublimation epitaxy in SiC are observed. Possible ways of development of this technology are discussed.

4) O. Lebedev, Yu V. Melnik and A.M. Tsaregorodtsev, *Thermodynamic analysis of chemical vapor deposition of SiC-AlN solid solutions.*

Thermodynamic analysis of SiH₄-CH₄-AlCl₃-NH₃-system have been carried out to see the possibility of deposition of AlN-SiC solid solutions in this system in proper perspective. The deposition region of (AlN) x (SiC) 1-x solid solutions have been determined in terms of experimental parameters. It is shown that an addition of hydrogen chloride into the vapor phase should expand the deposition region for AlN-SiC. The calculation revealed that the preparing the AlN-SiC solid solutions with small AlN-content using system under study involves difficulties.

5) A.O. Lebedev, Yu V. Melnik and A.M. Tsaregorodtsev, *Epitaxial growth of aluminum nitride on sapphire using modified chloride-hydride method.*

The gas-phase epitaxy of AlN on sapphire substrates in the system Al-HCl-NH₃-Ar was investigated. The effect of homogeneous formation of AlN on the deposition process has been discussed. The modified chloride-hybrid method, which may be called "chloride-hydride method with suppression of homogeneous formation," is proposed.

6) I.P. Nikitina, N.B. Guseva and S.V. Rendakova, *The effect of high temperature anneal on structural perfection of 3C-SiC Epitaxial Layers Grown by CVD on Si(111).*

The effect of high-temperature anneal on structural perfection of 3C-SiC epitaxial layers grown by CVD on Si(111) has been investigated by X-ray differential diffractometry and X-ray topography methods. It has been shown the anneal in vacuum at T= 1540 C led to considerable decrease of FWHM of rocking curves (RC) and made it possible to use such annealed epilayers as seeds for growth of cubicpolytype SiC bulk single crystals.

7) N.A. Rogachev, A.N. Kuznetsov, E.I. Terukov, V.E. Chelnokov and I.N. Trapeznikova, *Deposition of hydrogenated amorphous silicon-carbon alloy films by magnetron glow discharge plasma.*

Hydrogenated amorphous silicon carbide was prepared by reactive magnetron sputtering. Materials obtained by sputtering of carbon target in the atmosphere of argon-silane mixture as well as by sputtering of silicon target in the atmosphere of argon-methane mixture were compared. Electrical and optical absorption spectra of material obtained by various methods were found out.

8) N.A. Rogachev, A.N. Kutznetsov, E.I. Terukov and V.E. Chelnokov, *Growth of SiC epitaxial layers from the gas phase created by reactive magnetron sputtering.*

The obtaining of n-SiC epitaxial films by reactive magnetron sputtering method at substrate temperature higher than 900 C with different reactive gases, solid targets and their combinations as sources of films growing components is described. Crystalline Si, SiC and graphite plates were used as targets and silane, methane, argon as gases. It has been shown that this method allows to obtain n-SiC epitaxial films with difference in impurities concentration $Nd-Na=610 E18 cmE-3$. On the basis of the films obtained, Schottky barriers matrixes have been formed.

9) A.A. Maltsev, A. Yu Maksimov, I.P. Nikitina and N.K. Yuhin, *Structure investigations of large diameter bulk 6H-SiC single crystals.*

10) S.V. Rendakova, I.P. Nikitina and A.S. Zubrilov, *Properties of Annealed 3C-SiC CVD films.*

Effect of annealing of 9 μm thick monocrystalline 3C-SiC films on CL spectra, impurities concentration, crystallinity and resistance has been investigated. The pervasive character of oxygen in 3C-SiC samples irrespective of the growth technique has been established, with the minimum concentration measured $1.51 \times 10^{19} \text{ cm}^{-3}$. We find that O tends to accumulate near the regions of a high defect density. We propose that it is at least partially responsible for existence of the defect-related CL band in 3C-SiC films grown on Si.

11) I.N. Trapeznikova, O.I. Konkov, V.E. Chelnokov, E.I. Terukov and M.P. Vlasenko, *Effect of temperature annealing on the properties of a-Si(1-x)C(x):H films.*

The a-SiC:H structural and optical properties after vacuum and hydrogen annealing have been investigated. The hypothetical model of structural rearrangement is proposed.

12) V.K. Kudoyarova, G.M. Gusinskii, E.I. Terukov and V.E. Chelnokov, *Hydrogen and carbon depth profile measurement in a-Si(1-x)C(x):H films by elastic recoil detection.*

Amorphous silicon-carbon a-Si(1-x)C(x):H ($0 < x < 0.5$) alloys prepared by RF glow discharge decomposition of SiH and CH mixtures were studied. The experimental techniques used to study a-Si(1-x)C(x):H films were the Rutherford back scattering (RBS), elastic recoil detection (ERD) and IR spectroscopy. The results are reported of concerning the composition of films, the film density, the hydrogen content, the hydrogen and carbon profiles and IR absorption. The obtained data allowed to make certain conclusions about the a-Si(1-x)C(x):H ($0 < x < 0.5$) film structure.

13) A.N. Andreev, M.M. Anikin, A.L. Syrkin and V.E. Chelnokov, *The method for formation of a spectrally non-disordered silicon carbide surface in high vacuum.*

A new technique for clarification of silicon carbide surface under high vacuum condition is presented. This method includes preliminary oxidation. The oxide film is then removed in high vacuum by means of bombarding the surface with electrons. In this way the technique enables us to form a non-disordered spectrally clean silicon carbide

surface.

14) P.A. Ivanov, L.B. Elfimov, A.O. Konstantinov, V.N. Panteleev, T.P. Samsonova and V.E. Chelnokov, *Characterization of 6H-silicon carbide MOS-structures.*

The theoretical C-V characteristics of MOS-structures on the base of wide band-gap semiconductors like silicon carbide are discussed. Al/SiO₂/n-6H-SiC (0001) C and Al/SiO₂/n-6H-SiC (0001) Si MOS-structures have been fabricated and evaluated at room temperature. It has been shown that the charge trapping at the SiO₂/SiC interface is strongly affected by the oxidation rate which depends drastically on the surface orientation of SiC crystal.

15) A.O. Konstantinov, P.A. Ivanov, O.I. Konkov and E.I. Terukov, *Plasma passivation of crystalline silicon carbide.*

Plasma technique was shown to be an effective method of obtaining high resistivity layers in silicon carbide. The passivation mechanism is related with the intrinsic point defect production at crystal surface and with the subsequent diffusion of the defects into crystal bulk to form the defect complexes which compensate the shallow dopants. Due to the effect of Fermi level position on the process the method is effective for the p-type material, whereas only very thin high resistivity layers can be produced in the n-type one.

16) V.N. Makarov, D.A. Plotkin and A.V. Suvorov, *Graphitization of silicon carbide implanted by aluminum at high temperature of target.*

We studied 6H-SiC implanted with aluminum. The fluency was 5.10E16 cm⁻², the temperature of target was ranged from 300 to 1800 K. Implantation at 300 K resulted in amorphization of implanted layer. We found precipitates of microcrystalline Si in highly disordered SiC after 1300 K implantation. Above 1600 K graphitization of subsurface layer occurs. This process prevails at 1800 K. The effect of fluency on graphitization is also considered.

17) A.M. Strel'chuk, A.L. Syrkin, V.E. Chelnokov, A.E. Cherenkov and V.A. Dmitriev, *The current, electroluminescence and recombination parameters of SiC pn structures produced by container-free liquid-phase epitaxy.*

This paper presents a review of electrical transport, electroluminescent and

recombination properties of SiC pn structures produced by container-free liquid-phase epitaxy. At high temperatures thermo-activation currents are observed and investigated and at low temperatures influence of tunnel effect on current is detected. Lifetimes and charge carriers diffusion lengths are studied; a lifetime increase with elevation of temperature is detected. Temperature and current dependences of edge electroluminescence are investigated.

18) A.N. Andreev, M.M. Anikin, A.A. Lebedev, N.K. Poletaev, A.M. Strelchuk, A.L. Syrkin and V.E. Chelnokov, *A relationship between defect electroluminescence and deep centers in 6H-SiC.*

It has been found that if in 6H-SiC pn structures a defect electroluminescence (DEL) ($h\nu = 2.35$ eV) is observed then deep acceptor or i-centers ($E_v + 0.52$ eV) must be present there. A comparison of different mechanisms of radiative recombination showed that the best fit is obtained with the donor-acceptor pair recombination. It is considered that the acceptor level involved is i-center and the donor level is due to nitrogen.

19) A.M. Anikin, A.A. Lebedev, N.K. Poletaev, A.M. Strelchuk, A.L. Syrkin and V.E. Chelnokov, *Deep centers and blue-green electroluminescence in 4H-SiC.*

There were investigated 4H-SiC diodes with pn junction produced by ion implantation of Al (ID structures) or by epitaxial p-type layers onto epitaxial grown n-type layers (SE structures). In both types of samples there have been observed "defect" electroluminescence (EL) ($h\nu = 2.554$ eV) and "boron" EL ($h\nu = 2.4$ eV), respectively. DLTS data show the presence of D-center in samples displaying the "boron" EL and i-center in those displaying the "defect" EL, that is of the same centers which are responsible for EL in 6H-SiC. Calculation of 4H-SiC pn structures properties, assuming recombination models proposed for 6H-SiC, and of parameters of detected defects are in good agreement with the experiment.

20) V.V. Evstropov, A.M. Strel'chuk, A.L. Syrkin and V.E. Chelnokov, *The effect of neutron irradiation on current in SiC pn structures.*

The effect of neutron irradiation on forward and reverse current in 6H-SiC epitaxial pn structures was investigated. An evidence of tunneling was detected in the currents,

in particular, a change from thermal injection currents of the form $J = J_0 \exp(qU/nkT)$ with T-independent "n" to thermally-assisted tunnel currents having an analogous dependence on voltage but with T-dependent "n". Thermally-assisted tunnel currents in structures irradiated with a dose of $510 \text{ E}14 \text{ cmE-2}$ could be observed at temperatures of up to 600-700 K.

21) M.M. Anikin, A.M. Strelchuk, A.L. Syrkin and V.E. Chelnokov, *Diffusion length and lifetime of charge carriers in 6H-SiC pn structures.*

The diffusion length and lifetime of charge carriers in pn structures produced by different technological methods were studied. The link between values of the lifetime, the diffusion length and the rate of temperature variation of these quantities, on the one hand, and the fabrication technology of the pn structures, on the other hand, was observed.

22) A.S. Zubrilov, *Electrical transport properties of monocrystalline cubic-SiC/Si heterojunctions.*

The electrical transport properties of the monocrystalline n-beta-SiC/p-Si heterojunction (HJ) system fabricated by chemical vapor deposition (CVD) are investigated using the capacitance-voltage (C-V) and current-voltage (I-V) characteristics, as well as photovoltaic and minority carrier lifetime measurements. The HJs studied show good and fast rectification. The I-V characteristics can be given as $I = I_0 \exp(-qU/nkT) \exp(qV/nkT - 1)$, where the value of n is in the range 1.1 - 1.25, the build-in voltage $U = 0.87 - 0.02 \text{ V}$. An energy-band diagram of the HJs and the value of the SiC/Si interface density of states are presented.

23) K.V. Vassilevski, A.V. Zorenko and V.V. Novozhilov, *Temperature dependence of avalanche breakdown voltage of pn junctions in 6H-SiC at high current density.*

The temperature coefficient of avalanche breakdown voltage (b) of 6H-SiC p+n junctions was measured at high current density for the first time. P+n structures with various donor concentration in n-region (N_d) were formed on (0001) Si face of 6H-SiC substrates. The change of breakdown voltage (U_b) caused by diode heating during the current pulse was studied. It was found that the U_b decreases with the temperature rising from 300 to 750 K and increases from 750 to 900 K. An absolute b value

increases with Nd increasing.

24) E.V. Kalinina and G.F. Kholujanov, *Structure and electrical properties of implantation-doped pn junctions in SiC.*

Forward and reverse capacitance-voltage (CVC) and current-voltage (IVC) characteristics were studied of pnn+ structures produced by Al implantation (ID) into epitaxial layers of n-SiC in a wide range of ID and annealing regimes. Simultaneously, integrated profiles of implanted Al were studied by the method of resonant nuclear reactions. It has been shown that peculiar features of the electrical characteristics of these structures are due to the combined effect of the radiation-stimulated diffusion (RSD) and de-compensation of the players during anneal.

25) V. Kh Kudoyarova, D. Dimova, E.I. Terukov and V.E. Chelnokov, *Optical properties and structure of RF-magnetron sputtering a-Si(1-x)C(x):H films.*

Amorphous silicon-carbon alloys in a-Si(1-x)C(x):H ($0 < x < 0.5$) have been prepared by RF magnetron reactive co-sputtering of Si and graphite in Ar + H₂ gas mixture with 30% hydrogen concentration. The results of the optical band gap, refractive index, IR absorption and Raman spectra as function of film composition.

26) M.E. Kumekov, S.E. Kumekov, E.I. Terukov, V.A. Vassilyev and V.E. Chelnokov, *Quantum efficiency of the photoelectrical effect and impact ionization in a-Si:H films in the UV spectral range.*

The study of a-Si:H films photoconductivity over a wide energy interval (1.5 - 6.3 eV) has carried out. It was shown that quantum efficiency of the internal photo effect can exceed unity due to impact ionization showing a threshold at $E = 3.6 \text{ eV} > 2E_g$. The mean energy for electron-hole pair creation during impact ionization has been measured, amounting to 2.4 eV at $T = 293 \text{ K}$.

27) A.A. Babaev, O.I. Konkov, I.N. Trapeznikova, E.I. Terukov and V.E. Chelnokov, *Photoluminescence and optical properties of a-Si(1-x)c(x):H Films.*

The a-Si(1-x)C(x):H films photoluminescence properties are investigated after annealing at 400 C in vacuum. It is shown that photoluminescence intensity is increased after annealing as a consequence of the material structure rearrangement caused by annealing.

28) Ya V. Morozenko, *The effect of defects in substrate on the blue electroluminescence efficiency of epitaxial 6H-SiC pn structure.*

The correlation of the properties of 6H-SiC epitaxial pn junctions and 6H-SiC substrate used for epitaxy was investigated. A dependence of the electrical and electroluminescence characteristics of pn mesa structures on the light absorption coefficient was observed. This correlation may be used for the substrate selection before the epitaxial pn junction growth.

29) Ya V. Morozenko, *The spatial inhomogeneity of edge emission in 6H-SiC epitaxial layers.*

The spatial fluctuations of the quantum efficiency of exciton and donor-acceptor photoluminescence in epitaxial 6H-SiC layers were studied. A dependence of the mean relative deviation of the quantum efficiency on the shallow impurity concentration was examined.

30) P.A. Ivanov, N.S. Savkina, T.P. Samsonova, V.N. Panteleev and V.E. Chelnokov, *Junction field-effect transistor based on 4H-silicon carbide.*

A buried-gate junction field-effect transistor (JFET) based on 4H-silicon carbide has been fabricated and evaluated. p-Type and n-type homo-epitaxial films were successfully grown on a 4H-SiC wafer by vacuum sublimation. Ion-sputtered Ta/Al was used as an ohmic contact to both n-type conducting channel and p-type buried gate. A maximum transconductance of 15mS/mm was observed at room temperature. The device operated well at elevated temperatures with decreasing transconductance. An analysis of n-channel conductance yielded room temperature drift mobility of electrons 340 cm²/Vs being twice greater than that for 6H-SiC JFET with the same electron concentration in the channel.

31) M.M. Anikin, A.A. Lebedev, M.G. Rastegaeva, N.S. Savkina, A.M. Strelchuk, A.L. Syrkin and V.E. Chelnokov, *Low pinch-off voltage JFETs in SiC.*

New results in fabrication of JFETs based on sublimation grown epi-structures in 6H-SiC are presented. Low threshold voltages without essential decrease of drain current is obtained.

32) K.V. Vassilevski, V.A. Dmitriev and A.V. Zorenko, *SiC varactor operating at frequency 150 GHz.*

We report the fabrication of the first silicon carbide varactor. 6H-SiC pn structures were grown by container-free liquidphase epitaxy and encapsulated in microwave package. Fabricated diodes were used as varactors to tune in the frequency of silicon IMPATT oscillator. The frequency modulation about 6 MHz was obtained at frequency 150 GHz.

33) A.V. Suvorov and V.N. Makarov, *Prebreakdown electroluminescence of 6H-SiC Diode structure formed by ion implantation.*

Pn junctions with prebreakdown light emission were formed by Al⁺ ions and conventional thermal annealing of 6H-SiC. The produced structures show a wide radiation spectrum of electroluminescence in the range 400 - 800 nm. The spectrum is practically independent of temperature (100 - 500 K) and current density (10 - 1000 A/cm²). The homogeneous field of microplasmas with density of about 10E7 - 10E8 cm⁻² is the radiation area. The radiational power is about 0.1 mcW under current 40 mA.

34) A.V. Suvorov, V.N. Makarov and D.A. Plotkin, *High-effective ion-implanted green 6H-SiC LEDs.*

The pn structures were formed by the implantation of Al⁺ ions n-type 6H-SiC films and the thermal annealing. An energy of ions was in the range of 40 - 90 keV, an annealing temperature 1700 - 2000 K. We investigated the influence of implantation conditions over the defects electroluminescence of the obtained structures. After fabricating contacts and mesas with area 0.50.5 mm² our devices showed under the current of 20 mA:

- integral light power 20 mcW;
- $\lambda = 535$ nm, $d_l = 80$ nm.

After encapsulating it will be possible to obtain LEDs with an integral light power up to 80-100 mcW.

35) M.E. Kumekov, O.I. Konkov, E.I. Terukov, V.A. Vassilyev and V.E. Chelnokov, *UV-detector based on a-SiC:H Films.*

It was done investigation of photosensibility of photodetectors on base a-SiC:H and its alloys at temperature 300 C in the range of spectrum $1.5 < h\nu < 6.3$ eV. It was shown possibility of red bound shift of spectrum in dependence on thickness and i-layer composition.

36) A. Yu Maksimov, A.A. Maltsev and N.K. Yushin, *Silicon carbide application in integrated optics*.

Optical waveguide propagation was observed in SiC heteroepitaxial layered structure prepared by sublimation method. Some perspectives of SiC as an integrated optic material are discussed.

37) A. Yu Maksimov, A.A. Maltsev and N.K. Yushin, *Silicon carbide LED-modules and arrays*.

38) A.N. Andreev, M.M. Anikin, A.M. Strelchuk and V.E. Chelnokov, *Parameter evaluation for silicon carbide thyristors*.

An evaluation of switching and holding currents, switching and breakdown voltages is given for a SiC-based thyristor; peculiar features of silicon carbide as predetermine the thyristor specificity are considered. It has been shown that this the present development level of silicon carbide technology the switching voltage of a thyristor can be made as high as 500 - 700 V.

39) K.V. Vassilevski, *How far we are from silicon carbide diodes for 100 - 200 GHz*. The possibility of a SiC IMPATT diode creation is discussed taking into account recent results of theoretical and experimental investigations in silicon carbide. It was predicted numerically that a micro wave power generation with a maximum efficiency about 8% is available for the specific input power, P_{in} , of 10 MW/cm² at the frequency 140 GHz. A pulse avalanche current with a pulse length about 60 ns, density of 60 kA/cm² and the P_{in} value of 9 MW/cm² was passed through the 6H-SiC pn structures grown by liquid phase epitaxy.

2.2c Journal articles submitted for publication.

1) P.A. Ivanov, V.N. Panteleev, T.P. Samsonova, A.V. Suvorov and V.E. Chelnokov, 1153, *MOS-capacitor based on thermally oxidized n-6H-SiC(0001)C*, Fizika i Technika

Poluprovodnikov, 1993, v. 27, N7, 1146 .

Al/SiO₂/n-6H-SiC(0001)C MOS-capacitor with the thin thermal oxide (15 nm) as an undergate dielectric has been fabricated using dry oxidation and evaluated at the room temperature. The interface traps showing very large recovery time were found, with the density of 10E13/cmE2.

2) L.B. Elfimov and P.A. Ivanov, *Fizika i Technika Poluprovodnikov, Surface capacity of a semiconductor doped with deep level impurity.*

The known theory of surface capacity of a semiconductor has been modified for a case of wide band-gap semiconductor (like silicon carbide) with deep level dopant impurity. It has been shown that semiconductor surface capacity should increase with increasing surface potential modules (around zero value) both in the enhancement and depletion regime that is at variance with the classical theory. The minimum of MOS-capacity versus voltage near flat-band value that reported for MOS-structures with p-type SiC seems to be explained by the model considered.

3) A.O. Konstantinov, N.S. Konstantinova, O.I. Konkov, E.I. Terukov and P.A. Ivanov, *Passivation of crystalline silicon carbide in hydrogen plasma, Fizika i Technika Poluprovodnikov.*

Wafers of 6H-SiC were cured in hydrogen plasma at elevated temperatures. The curing resulted in shallow dopant removal and in high resistivity layer formation at the crystal surface. The electrical characteristics of the metal/semiconductor structures exhibit a transition from the classical Shottky barrier characteristics to those of the structures with space charge limited currents.

4) N.I. Kuznetsov, *Current deep level transient spectroscopy, (i-DLTS). Fizika i Technika Poluprovodnikov,*

i-DLTS has been described and advantages of this method over well known capacitance DLTS have shown. i-DLTS is very effective where applied to shallow level evaluation in wide band-gap materials like as SiC. Using i-DLTS technique D- and i-centers having close values of ionization energy were successfully separated in 6H-SiC pn-structures.

5) A. Yu Maksimov, A.A. Maltsev and N.K. Yushin, *Silicon carbide application in integrated optics, Pizma v Zhurnal Technicheskoi Fiziki.*

It has been shown that there is a possibility to satisfy the waveguide propagation conditions for double layer SiC structure consisting of different polytypes having different refraction index. So, the analysis of the refraction indexes shows that for the layers with thicknesses more than 1 μm the waveguide propagation can support in the 4H-polytype film grown on gH-, 15R- and 3C-substrates. Besides that, to combine SiC LED with the waveguide one can produce the SiC based optical circuit which may include acousto-optic and/or electro-optic modulators.

6) V.N. Makarov, D.A. Plotkin and A.V. Suvorov, *Raman scattering from aluminum implanted silicon carbide*, Fizika Tverdogo Tela.

Aluminum implanted silicon carbide was studied by Raman scattering. 6H-SiC and 4H-SiC were implanted with Al ions at 90 keV. Ion fluencies in the range $5 \cdot 10^{15}$ to $1.5 \cdot 10^{17} \text{ cm}^{-2}$ were used. Targets were maintained at temperatures 300-1900 K. Radiation damage and structural transformations were studied. Microcrystallites of Si and C were observed in implanted layers from Raman spectra. Microcrystallites of Si were formed at temperatures 1300-1600 K. "Spatial correlation" interpretation was used for analysis. Graphitization of high-temperature implanted SiC was studied. Decreasing of graphite crystallite size was observed with fluency increasing.

7) M.M. Anikin, A.M. Strelchuk, A.L. Syrkin, V.E. Chelnokov and A.E. Cherenkov, *Dependence of edge injection electroluminescence in SiC pn-structures on current and temperature*, Fizika i Technika Poluprovodnikov.

Some characteristics of the edge electroluminescence (EL) were investigated in 6H- and 4H-SiC pn-structures prepared by sublimation and liquid-phase epitaxy. The edge EL intensity has a power-law dependence on current and related to an exponent current-voltage characteristics. At $T > 300 \text{ K}$ the intensity of the edge EL rises with temperature and related to the fact that the lifetime of minority carriers rises with temperature.

8) A.N. Andreev, M.M. Anikin, A.A. Lebedev, N.K. Poletaev, A.M. Strelchuk, A.L. Syrkin and V.E. Chelnokov, *Relationship between defect electroluminescence of 6H-SiC and deep centers*, Fizika i Technika Poluprovodnikov.

It has been found that if in 6H-SiC pn-structures a defect electroluminescence (DEL)

(2.35 eV) is observed then deep acceptors or i-centers ($E_v + 0.52$ eV) must be present there. A comparison of different mechanisms of radiative recombination showed that the best fit is obtained with the donor-acceptor pair recombination. It is considered that the acceptor level involved i-center and the donor level is due to nitrogen.

9) M.M. Anikin, N.I. Kuznetsov, A.A. Lebedev, N.K. Poletaev, A.M. Strelchuk, A.L. Syrkin and V.E. Chelnokov, *About dependence of electroluminescence maximum of 6H-SiC diodes from the forward current density*, Fizika i Technika Poluprovodnikov.

In pn-structures fabricated by sublimation epitaxy, i-centers and D-centers were detected. D-center has identified earlier as an activator of yellow electroluminescence (EL) in 6H-SiC and i-center – as an activator of green EL. The EL peak in our pn-structures can occur in wide range from 2.14 eV to 2.35 eV and shifts from yellow to green with current density increasing. We explained this fact as the presence of two channels of radiative recombination due to i- and D-centers having different EL intensity dependencies on the current density.

10) M.M. Anikin, A.A. Lebedev, N.K. Poletaev, A.M. Strelchuk, A.L. Syrkin and V.E. Chelnokov, *A relationship between deep centers and electroluminescence in 4H-SiC diodes*, Fizika i Technika Poluprovodnikov.

It has been found that characteristics of electroluminescence (EL) in 4H-SiC diodes are identical with respective characteristics of 6H-SiC diodes except that in 4H-SiC diodes EL spectra are in more short wavelengths because of the larger band-gap. Calculation of properties of 4H-SiC diodes assuming recombination models proposed for 6H-SiC are in good agreement with the experiment.

11) A.N. Andreev, M.M. Anikin, A.L. Syrkin and V.E. Chelnokov, *Influence of different treatments on 6H-SiC(0001) surface*, Fizika i Technika Poluprovodnikov.

Influence of ion argon and nitrogen plasma, reactive ion etching in fluorine plasma, chemical etching and chemical extraction of oxide from oxidized sample on disorder and stoichiometry of 6H-SiC(0001) was investigated by Auger spectroscopy. Effect of heating and electron irradiation was investigated. It was occurred that stoichiometry deflection during heating depends essentially on the way of treatment before.

12) Ya V. Morozenko, *Influence of defects in substrate on the quantum efficiency of blue electroluminescence in 6H-SiC pn structures*, Fizika i Technika Poluprovodnikov.

In the present paper, the strong influence of point defects on the electrical and luminescent properties of epitaxial 6H-SiC pn junction is reported. A specific absorption in the visible range of spectrum occurs due to these defects that makes it possible to select the substrates before the epitaxy.

13) A. Yu Maksimov, A.A. Maltsev and N.K. Yushin, *Optical waveguiding in silicon carbide heteroepitaxial layered structures*, Electronics Letters.

Optical waveguide propagation was observed in SiC heteroepitaxial layered structure prepared by the sublimation method. Some perspectives of SiC as integrated optic material are discussed.

14) A. Yu Maksimov, A.A. Maltsev, S.G. Shulman and N.K. Yushin, *Deposition of ferroelectric films on silicon carbide*, Pizma v Zhurnal Technicheskoi Fiziki.

A possibility of creating high-temperature and radiation hard memory cells using ferroelectric films to be combined with silicon carbide structures is discussed. Electrical measurements of such film deposited onto 3C-SiC by laser evaporation showed high permittivity value of the film that is enough to produce a dynamic memory cell.

15) A. Yu Maksimov, A.A. Maltsev, E.A. Tarakanov and N.K. Yushin, *Elastic properties of bulk silicon carbide crystal*, Pizma v Zhurnal Technicheskoi Fiziki.

Elastic constants of bulk silicon carbide crystals grown by the modified sublimation process were obtained and a comparison with ones of Lely crystals was made.

16) M.M. Anikin, N.I. Kuznetsov, A.A. Lebedev, N.S. Savkina, A.L. Syrkin and V.E. Chelnokov, *i-DLTS investigation of the deep centers in 6H-SiC pn structures having built-in field in the base region*, Fizika i Technika Poluprovodnikov.

6H-SiC photo-diodes with the non-uniform doped n-type base were studied. One deep center trapping electrons and seven deep centers trapping holes were detected. It was shown that these centers provide the non-uniformity in the uncompensated impurity concentration within the diode base.

17) Ya V. Morozenko, *Spatial inhomogeneity of edge emission in 6H-SiC epitaxial layers*,
Fizika i Technika Poluprovodnikov.

The spatial fluctuations of the quantum efficiency of exciton and donor-acceptor photoluminescence in epitaxial 6H-SiC layers were studied. A dependence of the mean relative deviation of the quantum efficiency on the shallow impurity concentration was examined.

2.2d Journal articles currently in preparation.

1) M.M. Anikin, A.L. Syrkin and V.E. Chelnokov, *The ways of development of silicon carbide sublimation epitaxy*.

New ideas in the sublimation epitaxy of SiC are discussed. A comparison of results in several epitaxial methods of SiC growth is undertaken. Available and potential applications of the sublimation epitaxy are analyzed.

2) A.M. Strelchuk and V.E. Chelnokov, *Forward and reverse currents in SiC pn-structures*.

Forward and reverse current-voltage characteristics (CVC) of 6H-SiC pn-structures produced by sublimation, ion implantation and liquid-phase epitaxy were investigated. Thermal injection currents were found in forward CVC. They are assumed to be due to carrier recombination via deep-level and multi-level centers in the space-charge region. The diffusion current had to be calculated. The differences in forward current parameters for pn-structures grown by different techniques are discussed. Reverse generation currents (according to Sah-Noyce-Shockley model) become prevailing only at temperatures 700-800 K.

3) V.V. Evstropov, A.M. Strelchuk and A.L. Syrkin, *The current in SiC pn-structures after neutron irradiation*.

Forward and reverse current-voltage characteristics (CVC) 6H-SiC pn-structures produced by liquid-phase epitaxy were investigated, first prior to irradiation and then after two irradiation runs: 5.1×10^{13} and 5.1×10^{14} cmE⁻². Investigation of forward CVC in the temperature range 77 - 700 K displayed features characteristic of thermo-ionic currents at high temperatures and of tunnel currents at low temperatures.

4) A.N. Andreev, M.M. Anikin, A.L. Syrkin and V.E. Chelnokov, *Cleaning of silicon carbide surface using preliminary oxidation.*

Various methods of cleaning SiC surface are considered. It has been found that preliminary oxidation of the surface and subsequent cleaning with the use of electron beam bombardment under high vacuum yielded spectrally clean undisturbed surface.

5) A.N. Andreev, A.M. Strelchuk and V.E. Chelnokov, *Analysis of parameters of silicon carbide dynistor.*

In the present work, an evaluation is performed of achievable parameters of a dynistor in SiC (switching and holding voltages and currents, dynamic characteristics) based on study of pn-structures and base region characteristics, with an emphasis on obtaining maximum switching voltage.

6) N.A. Rogachev, A.N. Kuznetsov, E.I. Terukov and V.E. Chelnokov, *Investigations of SiC layers prepared by magnetron assisted deposition.*

Magnetron sputtering has been used for epitaxial growth of SiC layers. Structural, electrical and optical properties of such layers have been investigated.

7) N.A. Rogachev, A.N. Kuznetsov, E.I. Terukov, A.A. Lebedev, A.M. Strelchuk and A.L. Syrkin, *Preparation and investigation of Schottky barriers on SiC layers prepared by magnetron assisted deposition.*

Schottky barriers have been prepared on SiC layers deposited by magnetron assisted technique. Capacitance measurements have shown that the films have crystalline nature.

8) M.M. Anikin, A.A. Lebedev, M.G. Rastegaeva, N.S. Savkina, A.L. Syrkin, A.M. Strelchuk and V.E. Chelnokov, *Low pinch-off voltage JFET in 6H-SiC.*

JFET in 6H-SiC having low threshold voltage has been fabricated and evaluated. The channel length was 5 mcm, and width 0.8 mm. JFET showed a maximum drain current of 40 mA and maximum transconductance of 10 mA/V.

9) A.A. Lebedev, M.G. Rastegaeva, A.L. Syrkin, A.M. Strelchuk, N.S. Savkina and V.E. Chelnokov, *Investigation of epitaxial 6H-SiC layers grown by sublimation sandwich method in an electron heated cell.*

P-type and n-type epitaxial layers (EL) are investigated. A correlation between structural

and electrical properties of EL and technological conditions are determined. Photo- and electroluminescence, capacitance-voltage and current-voltage measurements are used for determination of characteristics of EL.

10) A.N. Andreev, M.M. Anikin, A.A. Lebedev, M.G. Rastegaeva, N.S. Savkina, A.M. Strelchuk, A.L. Syrkin and V.E. Chelnokov, *Physical and technological problems in silicon carbide power rectifier diodes.*

Physical and technological problems in silicon carbide power rectifier diodes are discussed. The requirements for the diode structure, as well as for ohmic contacts and packaging are considered with the dissipate heat limitations taken into account. A comparison was performed of calculated characteristics with experimental ones.

11) O.I. Konkov, E.I. Terukov, I.N. Trapeznikova and A.N. Kuznetsov, *Modification of a-SiC:H GD films by temperature annealing.*

The structural and optical properties of a-SiC:H are investigated under annealing. It was shown that amorphous net-work modification due to hydrogen diffusion and bonds redistribution takes place. The microcrystalline structure is observed at high temperatures.

12) O.I. Konkov, E.I. Terukov, I.N. Trapeznikova and A.N. Kuznetsov, *The influence of H⁺-plasma temperature annealing on the properties of sputtered stoichiometrical a-SiC films.*

Thin a-SiC films were produced by the sputtering of crystalline SiC target at temperatures more than 900 C. The decreasing of the defect density was observed under H⁺-plasma annealing.

13) O.I. Konkov, E.I. Terukov, I.N. Trapeznikova and A.N. Kuznetsov, *I-V characteristics changing under H⁺-plasma annealed of stoichiometrical a-SiC:H films.*

It has been shown that H⁺-plasma high-temperature annealing of a-SiC:H films allows to produce Schottky diodes with the ideality factor 1:2.

14) O.I. Konkov, E.I. Terukov, I.N. Trapeznikova and A.N. Kuznetsov, *Amorphous hydrogenated carbon films with high carriers mobility.*

The electron transport in a-C:H was investigated by time-of-flight method for the first time. The measured value of drift mobility was more than 2 cm²/Vs.

15) O.I. Knokov, E.I. Terukov, I.N. Trapeznikova and A.N. Kuznetsov, *Conduction band tail density of states in amorphous semiconductors.*

From the analysis of transient experiments the conduction band tail density of states in four-coordinated semiconductors was determined. The similarity in the tail shape was established.

16) V.A. Vassilyev and E.I. Terukov, *Impact ionization in a-Si(1-x)Ge(x):H alloy films.* Photoconductivity and impact ionization in a-Si(1-x)Ge(x):H films has been studied for types of specimen structure: Al/a-SiGe:H/Al in energy range 1.3-6.2 eV. The construction details of the impact ionization of the a-SiGe:H are described.

17) V.A. Vassilyev and E.I. Terukov, *On the temperature effect at the impact ionization in a-Si:H films.*

The study of the temperature effect on the impact ionization in a-Si:H films were investigated in the UV-range at 100 - 400 K. The temperature behavior of the quantum efficiency indicates that impact ionization is consistent with the mobility of the carriers and its T-dependence.

18) V.A. Vassilyev and E.I. Terukov, *UV photoresistors based on a-Si:H films.*

It was done an investigation of spectral and current photosensitivity of photoresistors on base a-Si:H films in the range of spectrum $1.5 < h\nu < 6.3$ eV. The photoresistors are very good detectors for UV-range up to 20 mW/cm². The degradation of the photodetectors after more power UV-irradiation is considered.

19) M.M. Mezdrogina and V. Kh. Kudojarova. *On the mechanism of boron doping a-Si:H films prepared in tetrode capassital system.*

Catalysis role of boron in growth mechanism of a-Si:H films has been taken into account. the electrophysical properties as a function of the concentration and the purity of diborane in gaseous mixture were investigated. the autocompensation model of doping is used for explanation of the experimental results.

20) A.M. Danishevski, M.S. Chusovitin, E.I. Terukov and V.E. Chelnokov, *Si-O clusters in near surface layer of SiC crystals.*

First experimental results of Raman scattering measurements of SiC crystal have shown the presence near surface silicon-oxygen clusters. These are microcrystals

being oriented by some way in the lattice of the SiC crystal. Possible mechanism of oxygen penetration into near surface of SiC and cluster formation is discussed.

21) A.O. Lebedev, Yu V. Melnik and A.M. Tsaregorodtsev, *Activation energy of chloride-hydride deposition process of ALN.*

The growth mechanism and parameters of chloride-hydride method which limit the process rate were investigated. The method has been proposed the activation energy to be evaluated.

22) A.M. Tsaregorodtsev, Yu V. Melnik and A.O. Lebedev, *Thermodynamic analysis of chemical vapor deposition process of SiC-AlN solid solutions.*

Thermodynamic analysis of SiH₄-CH₄-AlCl₃-NH₃ – system has been carried out to see the possibility of deposition of AlN-SiC solid solutions in this gas system in proper perspective.

23) E.V. Kalinina and G.F. Kholujanov, *Properties of implantation-doped pn junctions in SiC.*

It has been shown that using Al ion implantation into n-SiC, pn junctions can be obtained with the specified depth and required values of the gradient of electrically active acceptors within the junction. The conditions of the implantation doping (ID) have been established yielding p-layers which do not contribute to the diode structure resistance, so that forward currents of up to 40 kA/cm² can be passed. The developed ID technology permits to obtain pn junctions with guard rings in which uniform breakdown takes place at high values of the breakdown voltage and the electric field.

24) A.N. Andreev, P.A. Ivanov, N.S. Savkina, A.M. Strelchuk and V.E. Chelnokov, *Dynistor structure in 6H-SiC made by sublimation epitaxy.*

Dynistor structure in 6H-SiC was fabricated using sublimation epitaxy in an open system and electrical characteristics were studied in the temperature range 300 - 700 K.

25) P.A. Ivanov, A.O. Konstantinov, V.N. Panteleev, T.P. Samsonova and V.E. Chelnokov, *Charge properties of Al-SiO₂-n-6H-SiC(0001)Si MOS-structure.*

Al-SiO₂-n-6H-SiC(0001)Si MOS-structures have been fabricated and characterized at room temperatures. The gate oxide of 30 nm thick was thermally grown by the oxidation of (0001)Si-face of 6H-SiC at 1100 C, with C₂HCl₃ added in the dry oxygen

flow. In accumulation, the breakdown voltage was about 25 V that corresponds to the electric field strength 8 MV/cm. In a high non-equilibrium depletion, the MOS-structures showed very high reverse bias up to 300 - 350 V without any leakage that is due to the extremely low room temperature rate of the hole generation at the interface. The exponent law energy distribution of the acceptor-like interface traps within band-gap of 6H-SiC near conduction band was established with the total density $2.1 \times 10^{11} \text{ cm}^{-2}$ and the majority carrier capture cross-section 10^{-18} cm^2 . The fixed oxide charge was estimated to be 10^{11} cm^{-2} .

26) A.O. Konstantinov, P.A. Ivanov, O.I. Konkov, E.I. Terukov and V.E. Chelnokov, *High resistivity layer formation by the plasma treatment of p-type 6H-silicon carbide.*

Plasma technique has been shown to be an effective method of obtaining high resistivity surface layers in p-type 6H-SiC. The passivation mechanism is considered in terms of the intrinsic donor-like point defect generation at the crystal surface and the defect clustering with the subsequent defect penetration into the crystal bulk the process being accelerated by the surface electric field.

2.2e Journal articles currently in preparation.

- 1) *Photoelastic properties of silicon carbide single crystal.*
- 2) *Human study of 6H-4H heterojunction in silicon carbide.*
- 3) *Microwave absorption in high-resistivity single-crystal SiC films.*
- 4) *Epitaxial layer growth on large diameter SiC wafers.*
- 5) *Anisotropy of a saturated drift velocity in bulk 4H-SiC crystal.*
- 6) *Selective growth of silicon carbide epitaxial layers.*
- 7) *Memory cell with ferroelectric gate SiC field-effect transistor.*
- 8) *"Aluminum" electroluminescence and deep levels in 6H-SiC.*
- 9) *Deep centers in silicon carbide (review paper).*
- 10) *Growth of a-Si:H and mc-Si:H films doped with rare-earth elements.*
- 11) *Investigation of the surface photoluminescence origin in SiC.*

2.2f **Papers submitted to International Conferences.**

1) K.V. Vassilevski and V.A. Dmitriev (ISDRS93), *Silicon carbide read structure.*

The numerical calculations of dynamic characteristics of a SiC Read diode were performed in terms of the drift-diffusion model in a voltage driven mode of operation. A comparison calculated characteristics with those of a single-drift SiC IMPATT diode has shown that the Read structure is more suitable for operation as a high-power pulsed oscillator at the frequency 140 GHz.

2) M.M. Anikin, A.A. Lebedev, N.K. Poletaev, A.M. Strelchuk, A.L. Syrkin, V.E. Chelnokov and V.V. Chaldyshev (E-MRS93). *Electroluminescence (EL) of pn structures made from 6H-SiC by sublimation method.*

It has been shown that in the presence of both i- and D-centers the observed EL spectrum is a superposition of the green and yellow components. As the green EL tend to saturate at larger current density than yellow EL, their contributions to the total spectrum will be depended on the current so with increasing current the EL peak is observed to shift to the short wavelength part of the spectrum.

3) A.A. Lebedev and V.E. Chelnokov (4th European Conf. DDRM93), *Measurement of electrophysical properties of silicon carbide epitaxial films.*

In the present work, the parameters of the deep and shallow centers in 6H- and 4H-SiC epitaxial layers made by sublimation method in an open system has been investigated. Five deep centers in 6H-SiC and two deep centers in 4H-SiC have been identified. Temperature dependence of the diffusion potential of the pn structures made from these epi-layers and their degree of compensation have been considered.

2.3 **The Kurchatov Institute of Atomic Energy (Troitzk, Moscow Region); Yevgeny Velikhov, Director and Yu Baranov, Principal Investigator.**

2.3a **Key accomplishments.**

During the last year, our research activities were aimed at studies of different phenomena in a plasma induced by laser beam at the solid surface. A variety of laser sources were used: CW CO laser with output power of 300 kW, pulsed CO₂ laser with

1J/5 μ s, XeCl laser with 20J/0.5 μ s. Plasma diagnostic equipment included spectrographs, streak cameras, fast PMT and infrared detectors connected to digital oscilloscopes. In the course of our studies, several important and interesting physical effects were observed and thoroughly investigated.

[1] Rayleigh-Taylor instability of the boundary between expanding target plasmas and their ambient gases. The effect was observed in a wide range of experimental conditions and the methods of instability control and suppression were also investigated. Experiments with specially designed "sandwich" targets made of different materials allowed us to observe nonlinear evolution of initial perturbations with different spatial periods. Transformation of the unstable modes was recorded at times up to 20 inverse increments.

[2] Optical properties of multi-component plasma induced by pulsed UV or high-power IR laser beams have been studied and compared to predictions of both analytical and numerical models. Transient absorption and refraction phenomena were quantitatively studied. Comparison between effects induced by 10.6 and 0.308 micron pulses (in the microsecond pulse width range) demonstrated that refraction seriously affect beam propagation for 10 microns wavelength.

[3] Self-consistent computer models of laser-induced plasmas were improved and modified so that their predictions quantitatively agree with experimentally observed plasma optical properties and propagation velocities for laser wavelengths ranging from 0.3 to 11 microns and beam intensities from 10 MW/cm² to 50 GW/cm².

Experimental facilities have been modified and prepared for future experiments planned for the next year. A diagnostic system at the high power CO laser facility was completed, now it includes spectroscopics equipment with spatial and temporal resolution, plasma transparency/absorption probing system, thermal detectors, and high speed photography. Experiments on plasma optical properties are in progress at this laser facility.

The optical multichannel analyzer (OMA) available on loan from the University of Arizona is included in the system of digital data acquisition at the pulsed CO₂ laser facility. Combined with a diffraction grating monochromator, the OMA is extensively used in the

experiments on stability of UV pre-ionized discharge in the rare gases and methods of remote control of the discharge with laser-induced plasmas. Preliminary experiments on laser induced plasma flow interaction with surfaces and gases have been also started using the OMA.

On the territory of The National Research Center - Kurchatov Institute in Moscow a new room of 142 sq. meters was given to our research team by Academician E. P. Velikhov for a new laser-plasma interaction research facility. Construction work is scheduled to be completed by December of 1993, and in 1994 new laser and diagnostic equipment will be installed. This will considerably increase the pace of our work and widen the scope of studies.

2.3b Journal articles published.

1) V. Yu baranov, O. N. Derkach, V. G. Grishina, M. F. Kanevskii and A. Yu Sebrant, *Dynamics and stability of an expanding laser-induced plasma in a low-density gas*; Physical Review, vol.48, #2, Aug. 1993.

Experimental studies of a laser-produced metal plasma expansion into a gas with a mass density of $0.1-30 \mu\text{g}/\text{cm}^3$ have been performed using streak-camera imaging. The results show that plasma expansion dynamics can be described by a snowplow model with a dimension factor dependent on the laser focal spot shape. It has been shown that the plasma boundary becomes unstable at the moment of maximum deceleration (of the order of $10 \text{ cm}/\mu\text{s}^2$), and the evolution of boundary perturbation has been monitored. An explanation of the observed effect on the basis of Raleigh-Taylor instability is proposed and confirmed by comparison of simple model predictions with experimental evidence. The evolution of the plasma-front profile has been observed for the times $0 < \tau < 10\gamma^{-1}$, where γ is the instability increment. Competition of different unstable modes has been observed.

2.3c **Journal articles accepted for publication:**

1) V. N. Anisimov, V. Yu Baranov, V. A. Vorobiev, O. N. Derkach, M. F. Kanevskii, D. D. Maluyta, V. I. Nevmerzhitskii, I. V. Novobrantsev, A. Yu Sebrant and M. A. Stepanova, *Structure, dynamics and optical properties of multicomponent plasma produced near a surface by pulsed CO₂ and excimer lasers*, Proc. SPIE.

Results of the experimental studies of dynamics and optical properties of laser-induced plasmas are presented. Lasers with microsecond pulse width at $\lambda = 0.308$ and $10.6\mu\text{m}$ were used. Spatially and temporally resolved plasma emission spectroscopy and laser beam absorption measurements were used to reveal plasma plume structure. It has been shown that in the case of low absorption at the plasma front, a two component plasma is formed with gas plasma temperature above 3 eV and electron number density in both gas and target vapor plasma in the range $10^{17} - 3 \cdot 10^{19} \text{ cm}^{-3}$. Comparison of the experimental data with computer model predictions is presented.

2) V. G. Grishina, O. N. Derkach, M. F. Kanevskii and A. Yu Sebrant, *Target plasma front instabilities during the expansion in the ambient gas*, Kvantovaya Elektronika (Russian Journal of Quantum Electronics).

In this paper, new results are presented on the growth rates of Rayleigh-Taylor instability of the interface between the expanding target plasma and low-density ambient gas. Targets with alternating strips of different materials were used to produce initial spatial perturbations of plasma density profile. Non-linear saturation and competition of different unstable modes have been experimentally observed.

2.3d **Journal articles submitted for publication.**

1) V. N. Anisimov, V. G. Grishina, O. N. Derkach, V. Yu Baranov, I. V. Novobrantsev, A. Yu Sebrant and M. A. Stepanova, *Electrical discharge in rare gases, initiated by UV emission of laser-induced plasmas*.

Glow (current below 20 A) and arc (current above 10 kA) discharges in rare gases E/P below 5 V/cm. Torr were initiated by a microsecond UV pulses from laser-induced plasma on a metal surface. Discharge kinetics and transition from glow to arc mode

were studied experimentally. It has been shown that the discharge can be efficiently controlled by selecting laser pulse parameters.

2) V. N. Anisimov, V. Yu Baranov, V. A. Gurashvili, O. N. Derkach and A. Yu Sebrant, *Optical properties of a plasma plume ignited at a solid surface by a high power CO laser.*

Time resolved spectroscopy was used to study evolution of a plasma in front of a solid target ignited by a beam of CO laser with power above 100 kW. Absorption and refraction of the incident laser beam was studied for different focusing conditions.

2.3e **Journal articles currently in preparation.**

1) V. Yu Baranov and A. Yu Sebrant, *Laser-Induced plasma phenomena near a solid surface at incident intensities in the range 10 MW/cm² to 10 GW/cm²*, Trinti, Troitsk Moscow Reg., 142092 Russia.

Results of extensive experimental studies of properties of plasmas induced by microsecond pulses of carbon dioxide and excimer lasers are presented and compared with the predictions of self-consistent computer simulations. Both target material and gas plasmas have been studied.

Plasma dynamics was studied at the focal spot size in the range $0.1 < R < 0.5$ mm. At typical plasma front propagation velocity of more than 100 km/s, after tens of

2.4 **The Lebedev Physical-Technical Institute (Moscow); Igor Sobelman, Director and Igor Zhitnik, Principal Investigator.**

2.4a **Key accomplishments.**

This group has been working successfully at the development, production and testing of new optical elements and instruments for UV, EUV, X-ray and thermal neutrons radiation. The most important results achieved are:

(i) Aspherical (toroidal) multilayer mirrors at 175Å, with angular resolution better than 0.2 arc seconds (near diffraction limit) have been successfully demonstrated. Quartz crystal imaging spherical mirrors for 8.42Å wavelength and better than 5 arc. sec

have been created.

(ii) High resolution spectral images of laser plasma (angular resolution = 5", spectral resolution better than 10^3) near 192A have been obtained by means of a combination of a diffraction grating at grazing incidence and a focussing normal incidence multilayer mirror.

(iii) A set of laboratory and flight samples of imaging detectors, on the base of CCD (1000x1000 pixels, 5-100 microns resolution) and various wavelength converter screens, and spectral filters covering the wavelength region from 0.01-4000A and thermal neutrons (1000 x 1000 pixels, 5-10 microns resolution) have been created and tested.

(iv) A neutron tomography method for the study of three dimensional structures with resolution up to several dozen microns has been developed. First tomograms of turbine blades and honeycomb composite samples have been obtained. As far as we know, we have established record parameters concerning resolution, sensitivity and total efficiency. This technique can be very important for fundamental studies as well as for industrial applications, specially for nondestructive evaluations of high risk technologies such as airspace industry and nuclear energy.

2.4b Journal articles published.

1) S. V. Kuzin, I. A. Zhitnik, M. M. Mitropolsky, E. N. Ragozin, V. A. Slemzin and V. A. Sukhanovsky, *Characterization of X-ray multilayer mirrors for the 190 A range using a laser-plasma radiation source*, Kvantovaya Elektronika, Vol.19, pp. 89-94, 1993.

The laser-plasma XUV radiation source for investigation of focusing normal-incidence X-ray multilayer mirrors (MMs) was created using the second harmonic radiation of a single-mode Q-switched repetitive Nd: YA103 laser.

For the Mo-Si coated spherical mirrors worked in the 192A spectral range angular resolution better than 1" as well as spectral response function and its uniformity over aperture have been measured.

2) I. I. Sobelman and I.A. Zhitnik, *X-ray telescopes aboard the photos and coronas missions*, Proc. SPIE, v.1742, p.539-548 (1992).

A description of the instruments developed for solar XUV-observations on-board the Phobos-1 and Coronas-I missions is presented. These instruments are: [1] the XUV-imaging telescope TEREK (5-25, 175 and 304A spectral bands, resolution of 15"); [2] its modified version TEREK-C (130, 175 and 304A spectral bands, resolution up to 2"); [3] The multi-channel XUV-spectroheliometer RES-C (1.85-1.87, 8.41-8.43, 193 A spectral bands, angular resolution up to 6", spectral resolution up to 10000.) The instruments were designed using new types of X-ray imaging multilayer and crystal mirrors combined with intensified CCD-based detectors.

3) V. I. Mikerov, I. A. Zhitnik, V. V. Korneev, S. V. Kusin, A. A. Pertsov, I. P. Tindo, A. P. Ignatiev, V. A. Tukarev and W. Waschinkowski, *A two-coordinate high-resolution detector for registering of thermal neutron images*, J. Moscow Physics Society, v.2, 181-188 (1992).

The detector with resolution better than 70 micron, efficiency in registering of thermal neutrons of 65%, and sensitive surface of about 1 cm² is described. Some examples of images of technical and biological samples demonstrate a high potential of a detector for studying the inner structure of objects.

(4) I. A. Zhitnik, A. P. Ignatiev, V. V. Korneev, V. V. Krutov, A. V. Mitrofanov, S. N. Oparinn, A. A. Pertsov, V. A. Slemzin, I. I. Sobelman, I. P. Tindo, A. M. Urnov, B. Valnicek, R. Gudez and R. Peresty, *TEREK X-Ray images on the sun*, Proc. of the Lebedev Physics Institute, v.218, 1993.

2.4 c **Journal articles accepted for publication.** None at this time

2.4d **Journal articles submitted for publication.**

1) A. D. Akhsakhalyan, N. N. Kolaachevsky, M. M. Mitropolsky, E. N. Ragozin, N. N. Salashchenko and V. A. Slemzin, *Fabrication and investigation of imaging normal-incidence multilayer mirrors with a narrow-band reflection in the range 4.5nm*, Phys. Scripta, v.43, 1993 (in press.)

Soft X-ray spherical normal incidence mirrors (D=60 mm, r = 2000mm) with metal-carbon multilayer coatings, which provide a narrow-band reflection in the spectral range

$\lambda = 4.5\text{nm}$, have been synthesized using the pulsed laser deposition technique. The peak reflectivity of the multilayers reaches 13%, and the wavelength-to-bandwidth ratio $\lambda/\Delta\lambda = 80$. The spectral characteristics of the mirrors and their aperture uniformity have been evaluated using a broadband laser-plasma XUV radiation source. Discussed briefly are the applications to the investigation of complex spectra of broadband sources (the Sun, laser-produced plasma, etc.) employing telescopes for X-ray astronomy and stigmatic high-resolution laboratory spectrometers

(2) V. I. Mikerov, I. A. Zhitnik, A. P. Ignatiev, A. I. Isakov, V. V. Krutov, V. V. Korneev, S. V. Kuzin, S. N. Oparin, A. A. Pertsov, E. D. Podolak, I. I. Sobelman, I. P. Tindo and V. A. Tukarev, *High resolution neutron tomography on the basis of a CCD-detector*, Letters to the Journal of Experimental and Theoretical Physics (JETP), 1993 (in press.)

A system for neutron tomography with record parameters (1000x1000 pixels in an image, 50 microns space resolution, 60% efficiency of registration, a special image deconvolution procedure) and first experimental results are presented. The importance of this technique for some applications include: aircraft turbine blades and honeycomb composite materials testing, investigation of domain structure of magnetic materials, and investigation of biological samples structure .

(3) E. N. Ragozin, N. N. Kolachevsky, M. M. Mitropolsky, V. a. Slemzin and N. N. Salashchenko, *Characterization of imaging normal-incidence multilayer mirrors for the 40-300 Å range by spectroscopic techniques using a laser-plasma radiation source*, Proc. SPIE, v.2012, 1993 (in press.)

A number of high-performance normal-incidence multilayer mirrors (MMs) have been fabricated on concave ($r = 1.6 - 2.0\text{m}$) fused silica substrates using laser deposition and a magnetron ion sputtering source. The resonance wavelengths $\lambda = 2nd$ of the MMs synthesized are proximate to 45, 130, 175, 190 and 304 Å. The MMs have been subjected to scrutiny by a spectroscopic technique employing a laser-plasma broadband XUV radiation source. The spectral shapes of the resonance reflection curves, the ℓ values and the aperture uniformity (topography) of the mirrors have been determined spectroscopically. Normal-incidence reflection maxima, which correspond to higher-order reflection ($k_1 = 2n d, k > 1$.) have been observed for all of the Mo-Si

MMs with $\lambda > 175 \text{ \AA}$.

2.4e Journal articles currently in preparation.

1) A. Ignatiev, S. Kuzin, V. Krutov, V. Korneev, A. Mitrophanov, S. Oparin, A. Pertzov, E. Ragozin, V. Slemzin, I. Sobelman, I. Tindo and I. Zhitnik, *Fabrication, testing and calibration of the elements of XUV and X-ray optics for the CORONAS project*, In preparation for JOSA or Applied Optics.)

There were produced Bragg crystal optics for the solar XUV spectroheliograph RES-C. The mirrors for Mg XII line (8.42 Å) and Fe XXIV-Fe XXV lines (1.84 - 1.87 Å) were tested for efficiency and resolution in working region using X-ray tubes. The diffraction gratings for XUV channel or RES-C were measured by diffraction efficiency and spectral resolution in 170-200 Å. Multilayer mirrors for 45, 135, 170, 190 and 304 Å were tested for coefficient of reflectivity and resolution in working regions with a broadband laser-plasma XUV radiation source. Several types of thin film filters for XUV region were investigated efficiency of separation XUV from visible radiation. Some types of high-sensitivity imaging detectors for XUV region (0.1 - 30 nm) have been developed and tested.

2) A. Mitrophanov et.al., *Development of XUV filters on base of SiC thin films with high blocking of HLa VUV radiation*, (in preparation for SPIE Proc. or Applied Optics.)

2.4f Invited papers presented at conferences.

1) I. I. Sobelman and A. Zhitnik, *X-ray telescopes aboard the Phobos and Coronas missions*, SPIE's 1992 International Symposium on Optical Applied Science and Engineering, Proc. SPIE, v.1742, p.539-548.

2) V. Slemzin, E. Ragozin, E. Andreev, N. Kolachevsky, M. Mitropolsky and N. Salashchenko, *Fabrication and testing of imaging normal incidence multilayer mirrors for the XUV spectral region with high angular resolution*, Report to the 4th International conference on X-ray microscopy. Chernogolovka, Moscow region, Russia, 20-24 Sept., 1993 .

For many applications such as X-ray microscopes, X-ray solar telescopes and other

XUV-imaging devices, production of highest possible imaging multilayer optics is of vital importance. Modern state-of-the-art multilayer mirrors can possess imaging quality corresponding to an angular resolution of several tenths of an arc second [1]. For mirrors several cm in diameter it is far lower than the diffraction limit for visible light, so special methods of their testing are needed. Here we report the results of manufacturing in Russia of the imaging spherical and aspherical (thyroidal) multilayer mirrors for 175 and 193 Å spectral intervals with an angular resolution better than 1 arc-second. The Mo-Si multilayer-coated mirrors with diameter 3 and 6 cm and radius of curvature 1.6 and 2 m were made on superpolished fused quartz blanks (sigma 5-7 Å) by magnetron sputtering. Imaging characteristics were evaluated by means of short pulse laser-plasma XUV radiation source [2], which removed complicated problems of mechanical stability and vibrations.

2.4g Contributed papers presented at conferences.

1) E. N. Ragozin, N. N. Kolachevsky, M. M. Mitropolsky and V. A. Slemzin, *Measurements of the spectral response function and its uniformity over aperture for imaging normal-incidence multilayer mirrors working in the 44Å - 304 Å band*, Report to the 4th International conference on X-ray microscopy. Chernogolovka, Moscow region, Russia, 20 - 24 Sept. 1993.

Spectral response and throughput of any XUV optical system based on narrowband multilayer mirrors and their matching with the spectra of the radiation source and each other. A number of imaging normal-incidence multilayer mirrors for the 44-304 Å spectral region made by laser deposition and magnetron sputtering methods have been tested using a broadband laser-plasma XUV radiation source [1]. For short wavelength mirrors (44Å band) with Ni-C or Fe-C coatings local spectral resolution of 0.5 Å was achieved, but the total resolution is lower because of non-uniformity of a stack period over aperture [2]. For mirrors with Mo-Si coating (135, 175 and 304 Å bands) the spectral resolution is governed mainly by the shape of the spectral response function. The role of higher-order interference maxima and the Fresnel broadband reflection is

analyzed.

2) V. I. Mikerov, I. A. Zhitnik, V. V. Korneev, S. V. Kuzin, A. A. Pertsov, I. P. Tindo, A. P. Ignatiev, S. N. Oparin and E. R. Podolak, *A high resolution detector for computerized neutron radiography and tomography*, International conference "Nuclear energy in Central Europe: Present and Perspectives, 13-16 June, 1993, Portoroz, Slovenia.

3) A. V. Mitrofanov and F. A. Pudonin, *Composite thin film bandpass filters for the 135 A X-ray microscopy*, Report to the 4th international conference on X-ray microscopy, Chernogolovka, Moscow region, Russia, 20-24 Sept. 1993.

4) We have had fruitful contacts in the frame of Sun satellite CORONAS project at the Goodard Space-Flight Center and Harvard Smithsonian Center for Astrophysics, where in December, 1992, I. Zhitnik presented report about goals of project, description of instruments and some results of developing this short wave optics.

5) We intend to send abstracts of reports to the "Space Optics" International Symposium (Germany, Berlin, May 1994) and "Optical Interference Coatings (France, Grenoble, June, 1994.)

2.5 The Institute of Spectroscopy (Troitzk, Moscow Region); Yevgeny Vinogradov, Director and Vladilen Letokhov, Principal Investigator.

The transition of a progress report from this Institute was accomplished by fax and with some unfortunate "garbling" of the text. Accordingly, we submit the appropriate publication summary together with the abstracts of each which did come through in a separate communication. We believe that this material will serve to give an appropriate overview of the principal accomplishments.

2.5a Key accomplishments.

Approximately 40 researchers, ranging from graduate students to senior professors, have been supported by the Arizona contract. One of the major achievements has been the discovery that multicharged ions in high power laser induced plasmas exhibit a new type of quantum transition, a so called "mixed electron-nuclear transition" with

simultaneous change of quantum states of both the electron shell and the nucleus. This opens the potential possibility of a new type of laser based on a combination of a gamma-laser and an X-ray laser.

Another key achievement has been the discovery of a laser-induced step-wise resonant photoelectric effect for absorbing centers (doped rare-earth ions) on crystal surfaces. This opens a real possibility for the development of laser resonant photoelectron spectromicroscopy with spatial resolution much better than optical wavelength.

We have had two results in our endeavors with laser ultrasensitive detection of trace elements and rare isotopes: we now have the first experimental observation of ionization of fast Rydberg atoms by magnetic (not electric!) fields. This is important for the development of a laser based method of detection of very rare long-lived isotopes. The second result has been a measurement of nanogram quantities of ruthenium, rhodium and iridium in kimberlites by laser resonant ultra sensitive ionization of atoms. Finally, we have been able to understand, in detail, the physical mechanism of laser ablation of absorbing materials; particularly, the row of pulsed pressure waves (hundreds of atmospheres) and spatial heterogeneity of the distribution of absorption and laser light intensity.

Finally, by using femtosecond high-power laser pulses we have studied the ultra fast laser-induced darkening (not bleaching!) of a new type of material: thin films of carbon 60 fullerenes. We have observed the contribution of two-photon and two-step resonant absorption in this material.

2.5b **Journal articles published.** None at this time.

2.5c **Journal articles accepted for publication.**

1) A. L. Dobryakov, V. M. Parztdinov, Yu. E. Lozovik and V. S. Letokhov, *Energy Gap in the Superconductor Optical Spectrum*, Optics Comm.

Superconducting gap D manifestation in optical spectra for frequencies $\omega \gg \Delta$ η (??) corresponding to interband transitions is studied. A characteristic structure in the difference spectrum of the superconducting and normal phases, with its width connected with Δ , is predicted. Experimental manifestations of the predicted effect are discussed.

2) E. V. Moskovets and V. S. Letokhov, *"Cat's Eye" reflection*, Appl. Phys.

A new version is described of the non-magnet time-of-flight mass spectrometer, and method of its operation, which allows to separate the packets of ions with different masses both by their time of flight and by their deflection angle in the deflection system which operation is synchronized with the arrival time of the ions in the focusing plane of this time-of-flight mass spectrometer.

3) V. V. Klimov and V. S. Letokhov, *Radio Emissions of an Optical Solution Propagating in a Ring Fiber*, Optics Comm.

This paper considers emission processes occurring in the course of propagation of an optical solution along a ring fiber. The spatial and temporal characteristics of radiation are calculated. It is demonstrated that conditions are possible in which radiation becomes observable.

4) S. K. Sekatskii, V. S. Letokhov, T. T. Basiev and V. V. Ter-Mikirtychev, *Selective Two-Step Laser Resonance External Photoelectric Effect in F_2 Color Centers of LiF Crystals*, Appl. Physics.

Laser resonance two-step external photoelectric effect is revealed in the F_2 color centers of LiF crystals exposed to nanosecond laser pulses. The first photoionization step uses IR radiation tunable within the resonance absorption band of the color centers and the second step, the second harmonic of a Nd:YAG laser. The photoionization cross sections of the F_2 centers are estimated.

5) E. A. Yukov and V. S. Letokhov, *Excitation of isomeric low-lying levels of heavy nuclei in laser-induced plasma*, Laser Physics.

Electronic excitation of low-lying metastable levels of heavy nuclei in plasma generated by terawatt femtosecond laser plasma is considered.

6) V. V. Golovlyov and V. S. Letokhov, *Laser Ablation of Absorbing Liquids: Acoustical Microfragmentation Mechanism*, Applied Physics.

We have studied experimentally the formation of microdroplets upon the ablation of an aqueous CuCl solution by a pulsed laser radiation. Laser fluence dependences are obtained of the number of droplets formed and of their statistical size distribution. The experimental data obtained can be explained within the framework of our acoustical microfragmentation model providing for excitation and interference in the field of laser acoustic waves of random phases. The ablation mechanism suggested is of universal character and manifests itself particularly in the laser ablation of biotissue.

7) V. V. Goloylyov, R. O. Esenaliev and V. S. Letokho, *Ablation of an Optically Homogeneous Absorbing Medium by Scattered Pulsed Laser Radiation*, Applied Physics.

We have studied the ablation of an aqueous CuCl₂ solution in a laser filed featuring a speckle-patterned structure characterized by spatial radiation energy fluence fluctuations. This leads to a nonuniform distribution of the energy absorbed in the bulk of the sample being irradiated and causes local overheating centers to form, wherein ablation is observed to take place at laser energy fluences below the threshold value found in experiments with a homogeneous laser beam. This effect should be manifest in the laser irradiation of biotissues which, as a rule, scatter light strongly.

2.5d Journal articles submitted for publication.

1) V. S. Letokhov, *Partial Inversion of Populations for electron-nuclear transitions of multicharged ions*, Optics Comm.

Amplification on mixed electron-nuclear transitions of multicharged ions in particularly the inversion of population on such gamma transitions due to inversion of electronic states without inversion of nuclear states are considered.

2) V. V. Klimov and V. S. Letokhov, *A Simple Theory of the Near Field in Diffraction by a Round Aperture*, Optics Comm.

Simple expressions are obtained in terms of elementary functions for the near

6) E. V. Moskovets and V. S. Letokhov, *Absolute Elimination of an Ion TOF Spread in the TOF Mass Spectrometer Caused by Initial Ion Spatial Distribution*, Applied Physics.

The system is proposed that can serve as a TOF mass spectrometer in those experiments where ions are produced from moving atoms or molecules under the action of short pulse of ionizing radiation. This system can diminish materially the TOF spread in the arrival times of moving ions to the ion detector caused by their different initial position in respect to the detector. It is demonstrated that the TOF mass spectrometer of the given type can effectively be used in molecular RIS experiments where the molecules under investigation are cooled in pulsed supersonic jets. The combination of the TOF scheme proposed and the fast atom multistep ionization spectroscopy can in some cases increase materially the mass selectivity of the method.

7) Yu. B. Ovchinnikov, A. I. Sidorov, R. Grimm and V. S. Letokhov, *Resonant Light Pressure on Atoms in Bichromatic Standing Wave*, Optika i Spektroskopia (Russian). Results of theoretical and experimental study of radiative force acting of neutral atoms in strong bichromatical standing laser wave are presented.

2.5e Journal articles currently in preparation.

1) S. K. Sekatskii and V. S. Letokhov, *Laser resonance photoionization of absorbing centers on surface*, Optika i Spektroskopia (Russian).

2) M. Ol'shanyi, Yu. Ovchinnikov and V. S. Letokhov, *Laser Cooling of Atomic Particles* (review), Quantum Optics.

3) V. I. Balykin and V. S. Letokhov, *Atomic Optics with Laser Light*, Series of Books "Laser Science and Technology", Harwood Acad. Publ.

4) Yu. A. Kudriavtsev and V. S. Letokhov, *Laser Detection of Very Rare Isotopes*, Series of Books "Laser Science and Technology", Harwood Acad. Publ.

5) S. Hurst and V. S. Letokhov, *Laser Resonant Ionization Spectroscopy*, Physics Today.

2.5f Invited papers presented at conferences. None at this time

2.5g Contributed papers presented at conferences. None at this time