

AOARD REPORT

Daido Steel's Shibukawa Plant, Shibukawa City, Gumma
Prefecture, Japan, 29 Jul 94

29 Jul 1994
P. McQuay
AOARD



Daido Steel is the largest specialty steel maker in the world, and therefore has a strong interest in aerospace materials, such as heat and corrosion resistant steels, and Ti and Ni-based alloys. Daido Steel features some of the most advanced melting and processing equipment and practices available, and appears to be constantly upgrading their facilities and capabilities. Daido Steel has recently designed and is now testing an in-house developed unique spin forming press, designated the SRH, for Spinning and Rolling - Hot. This unique press allows for complex case and ring production in a single work piece, with the ability to produce both variable diameter and thickness with good precision. Additionally, utilizing it's high speed rotary forge, the Shibukawa Plant has unique capabilities for producing very large turbine shafts economically. Several Ti alloy/part development programs currently underway are also reviewed.

AIR FORCE OFFICE OF SCIENTIFIC RESEARCH

ASIAN OFFICE OF AEROSPACE RESEARCH AND DEVELOPMENT

TOKYO, JAPAN
UNIT 45002
APO AP 96337-0007
DSN: (315)229-3212
Comm: 81-3-5410-4409

19950321 085

DISTRIBUTION STATEMENT A:
APPROVED FOR PUBLIC RELEASE; DISTRIBUTION IS UNLIMITED.

DTIC QUALITY INSPECTED 1

2. OVERVIEW AND BACKGROUND

Daido Steel, founded in 1916, is the largest specialty steel producer in Japan and the world. In fact, Daido claims to have approximately 90% of the specialty steel market in Japan. Total sales for 92 were \$2.51B, slightly off from 91 sales of \$2.73B. The largest customer for their products is the automobile industry (35%), and as such, they are currently experiencing difficulty economic times.

In total, Daido Steel has nine plants located at seven works which specialize in the following products:

- Shibukawa Plant: Rolled and forged steels
- Takakura Works and Fabricated Steel Products Plant: Industrial furnaces, robots, anti-pollution facilities, automotive parts and aircraft parts
- Chita Plant and Chita Steel Strip Plant: Rolled steels, hoop steels and die-forged steels
- Oji Plant: Hoop steel products
- Tsukiji Plant: Cast steels, magnetic products, and powdered alloys
- Hoshizaki Plant: Rolled steels
- Kawasaki Plant: Rolled steels

A brief profile of the activity of the Hoshizaki Plant is given in AOARD TR-94-15. Daido Steel also operates a Central Research Laboratory, which is located in Nagoya.

The Shibukawa Plant, which opened in 1937, is located in Shibukawa City, Gumma Prefecture, about 100 km North of Tokyo. It is a rural and very picturesque area known for it's skiing, hiking and hot spring resorts, which are located in the nearby mountains.

The monthly output capacity of the Shibukawa Plant is approximately 6,500 tons (metric) of forgings, 3,000 tons of rolled bars, and 1,500 tons of billets. The main products from the plant include component parts or materials for aircraft engines, chemical plants, power stations, iron and steel industry, shipbuilding, and tools.

3. DISCUSSIONS AND PLANT TOUR

This visit was arranged upon request of Dr. Fujishiro, AOARD/CC, whom I accompanied. The main purpose of the visit was to see a new experimental hot spinning mill, which will be described later.

Our primary host for the discussions and tour was:

Mr. Hiroh Inamori
 General Manager, Shibukawa Plant
 500 Ishihara
 Shibukawa, Gunma
 Japan
 Tel: +81 (279) 25-2001; Fax: +81 (279) 25-2040

Following introductions, we were given an outline of the production process of rolled and forged bar at the plant. Typical of a specialty steel producer, the starting material for the production of specialty steel is steel scrap. Both continuous and batch type processes are used, depending on the quantity of material to be produced, and the product form.

Attachment one contains a listing of the major manufacturing equipment (furnaces, presses, rolling mills, etc.) which are utilized at the Shibukawa Plant. The plant operates six

For	<input checked="" type="checkbox"/>
AI	<input type="checkbox"/>
ed	<input type="checkbox"/>
tion	
on	
ity Codes	
and/or	
Plot	special

A-1

Vacuum Arc Remelting (VAR) and Electro-Slag Remelting (ESR) Furnaces each, of various sizes, the largest in each case being a 10 ton furnace. One of the VAR furnaces has been converted into an experimental hybrid VAR-ESR furnace, named a VSR for Vacuum-Slag Remelting Furnace. The experimental furnace is being used to examine the feasibility of creating a single process using the best features of both furnace technologies.

Although not at the Shibukawa Plant, Daido's Hoshizaki Plant (see AOARD TR-94-15) operates a unique Plasma Progressive Casting (PPC) unit. This unit gives Daido Steel a unique plasma-based melting technology for melting a combination of sponge and scrap Ti, and master alloys. A schematic and several additional fact sheets for the PPC unit is given in attachment two.

Although the overwhelming majority of its business is specialty steel, Daido also produces superalloys, and Ti and Ti alloys. The main aero-engine products of the Shibukawa Plant are shafts and disks.

In the area of forging, the plant has an NFP Forging Machine (GFM-SXP55) which is a kind of rotary hammer forge which operates at very high speed and can produce cylindrical components to a rough product shape. This process can dramatically reduce the time and cost associated with producing a worked cylindrical bar piece for applications such as large shafts. They also have conventional hydraulic presses of 3500, 2600, and 1500 ton capacities.

From 1985 to 1993, Daido Steel has produced a total of 1300 turbo-engine shafts. The first mass-produced commercial shafts were produced for the V2500, and subsequently, shafts have been produced for the PW 2037 and 4056, the JT9D, and the GE 90. Daido is currently working on a new shaft development program with IHI and Rolls-Royce, presumably for the Trent engine program.

It is interesting to note that prior to Daido's entrance into the aero-engine shaft business, Daido enjoyed the development support of the Japanese government on at least four separate engine development programs to produce shafts, from 1975 to 1983. These programs were for titanium, steel and nickel-base superalloy shafts.

Through an affiliated company, the plant has access to numerous ring rolling mills for producing cases for aerojet and rocket engines. However, the pride and joy of Daido's processing equipment is an experimental spin forming machine, oddly named the SRH, for Spinning and Rolling - Hot. This in-house developed machine provides a unique capability to produce complex single-piece case structures, with variable diameters and an impressive ability to produce risers and complex cross-sections. The minimum and maximum ring or case diameters are 200-1600 mm. The maximum width of the base material is 150 mm, while the maximum for the finished part is 450 mm. The minimum thicknesses for the base material and product are 30 mm and 1.5 mm, respectively.

The unique design features of the SRH unit enable the production of a single ring or case with variable thickness, as well as diameter. It has much more flexibility and capability compared to a conventional ring-rolling mill. It can produce a heavily reduced complex part with near net shape detail in less than 30 minutes. Another unique feature is a built in induction heater, which heats the workpiece as it spins, opposite the tool. Reportedly the induction heater has a maximum workpiece temperature of up to 1200°C.

The unit has been in a test program for over a year. Most of the preliminary work has been accomplished on steel, but the unit is also envisioned to produce Ti, and Ni-based alloy parts. Attachment three contains a schematic and additional specifications of the SRH unit.

The Shibukawa plant is currently involved in several Ti alloy prototype programs. The first program is to develop a commercially successful Japanese disk alloy in collaboration with IHI. The two year program began in 1993, and is being sponsored by the Japan Aerospace Industrial Association. In particular, one of the main goals of the program is to develop a dual property disk alloy, where the mechanical properties at the rim and the bore of the disk are different.

The program alloy is called RNT101, and is considered a near beta alloy, with the following composition: Ti-5.7Al-4.0Sn-3.4Zr-3.0Mo-0.7Nb-0.3Si-0.06C. The alloy bears an obvious resemblance to IMI834, with the largest variation being the decrease in Zr and the increase in Mo. The increase in Mo was to boost the creep resistance (time to 0.5% creep strain at 600°C and 200 Mpa). Several of the technical challenges involved were melting practices and hot working practices to produce homogeneous material. In the case of melting a combination of PPC plus double VAR was used successfully. The ingot breakdown was performed using the GFM to minimize the heat loss and maximize the amount of uniform hot work.

Following the ingot breakdown, pancakes were two step forged, first beta and then alpha plus beta forged, and subsequently heat treated to two microstructural conditions: a beta anneal which produced a transformed beta microstructure, and an alpha plus beta anneal which produced a duplex microstructure. The results of the mechanical properties demonstrated that both microstructures have higher room and elevated temperature strength than IMI834, that the low cycle fatigue behavior is comparable, and that the creep resistance of the alpha plus beta anneal material is superior to IMI834. Future plans are to continue the microstructure/ property development of the alloy, and a manufacturing trial for a full-scale disk prototype with a dual property heat treatment.

The second development program Daido is working on is aimed at the production of forged Ti-17 disks, using the GE specification C50TF57 as a baseline for their property goals. The initial small scale prototype disk was reportedly a success, in terms of producing the part shape with no defects, achieving the desired microstructure, and achieving the property goals. A follow-on program is now under way to develop a full scale disk prototype.

Additional information regarding most of the above subjects is available upon request.

4. SUMMARY AND COMMENTS

Daido features some of the most advanced melting and processing equipment and practices available, and appears to be constantly upgrading their facilities and capabilities. Clearly, the SRH unit provides a very unique capability to produce complex wrought cases and rings, while reducing processing steps, part counts and welding and joining issues.

Daido's entrance into aero-engine shaft business through government support is probably indicative of their future attempts to become a player in the aero-engine part manufacturing business. The next target of opportunity appears to be in the manufacture of disks. They appear to have the expertise, technology and determination to become a major player worldwide.

Please Note: Attachments are available only in the hard copy version of this report.

Major Manufacturing Equipments

Kind of Process	Equipment	Capacity / Model	Number of Units
Melting	Basic Electric Arc Furnace	25 t	1
	High Frequency Induction Furnace	15 t	2
		5 t	1
		3 t	1
	Vacuum Induction Furnace	3 t	1
	Argon Oxygen Decarburization Furnace	20 t	1
	Vacuum Ladle Furnace	30 t	2
Continuous Casting Machine	Mannesmann Type	1	
Remelting	Vacuum Arc Remelting Furnace(VAR)	10 t	1
		7 t	1
		6 t	2
		3 t	1
		2 t	1
	Electro-Slag Remelting Furnace(ESR)	10 t	1
		7 t	2
		6 t	1
		1 t	2
Forging	NFP Forging Machine(GFM-SXP55)	1200 t	1
	Oil Hydoruric Press	3500 t	1
		2600 t	1
		1500 t	1
		1500 t	1
	Ring Rolling Mill(Affiliated Company)	RAW 125/80-2500	1
		RAW 80/50-1400	1
		KFRW-630	3
		RICA 250-V	1
		R3 Line	1
R4 Line		1	
Rolling	Medium Size Bar Mill	3-High Parallel Type	1
	Narrow Strip Mill	4-High	
		Continuous Type	1
Heat Treatment	Oil Fired Furnace	Car Type	1
	Electric Furnace	Car Type	5
		Batch Type	1
		Pit Type	2
	Vertical Electric Furnace	Pit Type	2
	Gas Fired Furnace	Car Type	8
	Continuous Annealing Furnace	Roller Hearth Type	2
Roller Hearth Type		2	
Machining	Bar Turner	max. Dia. 220mm	3
	Machining Center	1300Wx3500Lx950H	1
	Lathe, Vertical Lathe	Max. Dia. 3500mm	19
	Milling Machine	1400Hx950Wx4700L	3
	Horizontal Boring Machine	Max. Dia. 450mm	2
	Boring Trepanning Association etc	Dia.450 x 5000L	2

Major Inspection & Testing Equipments

Kind of Test	Equipment	Model	Number of Units	
Mechanical Properties Test	Tensile Testing Machine	Screw Type 25t	1	
		Amsler Type 30t	1	
		// 20t	1	
	Hardness Testing machine	Brinell		6
		Rockwell		2
		Vickers		1
		Microvickers		1
		Shore		8
	Impact Testing Machine	Charpy(ASTM Type) 37Kg-m		1
		Charpy 30kg-m		2
		Izod 17Kg-m		1
	Creep Rupture Testing Machine	Single Type max. 1200°C 0.25-3t		45
		Multiple Type max. 900°C 1.5t		2
	Hardenability Testing Equipment	End Quench		1
Salt Spray Testing Equipment			1	
Chemical Analysis	Fluorescent X-Ray Analysis Equipment	Multi-Channel		
		Simultix - 6 Type	1	
		Simultix - 8 Type	1	
	Carbon-Sulfur Determinator	IR matic VK111 Type	1	
		LECO CS244 Type	1	
	Oxygen-Nitrogen Determinator	LECO TC136 Type	1	
	Emission Spectrochemical Analyzer	GVM-101	1	
	Hydrogen Determinator	Horiba EMGA-5 Type	1	
	Atomic Absorption Spectrophotometer	Shimazu AA 640-13 Type	1	
		AA 680 Type	1	
Spectrophotometer	Shimazu UV160 Type	1		
Centrifugal Casting Machine	Scrap Analysis AURUM 05/0C Type	1		
Glass Bead Sampler	Slag Analysis	1		
Metallurgical Test	Macro Scopic Testing Equip.		1	
	Metal Microscope		5	
	Electron Probe Micro Analyzer		1	
Nondestructive Test	Ultrasonic Testing Equipment	Tokyo Keiki : UM731, SM100 KRAUT KRAMER: KB6000,USIP11	24	
	Magnetic Particle Testing Equipment	TF60, TF65, NQ600SB	4	
	Flourescent Penetrant Testing Equipment	MA-1	1	

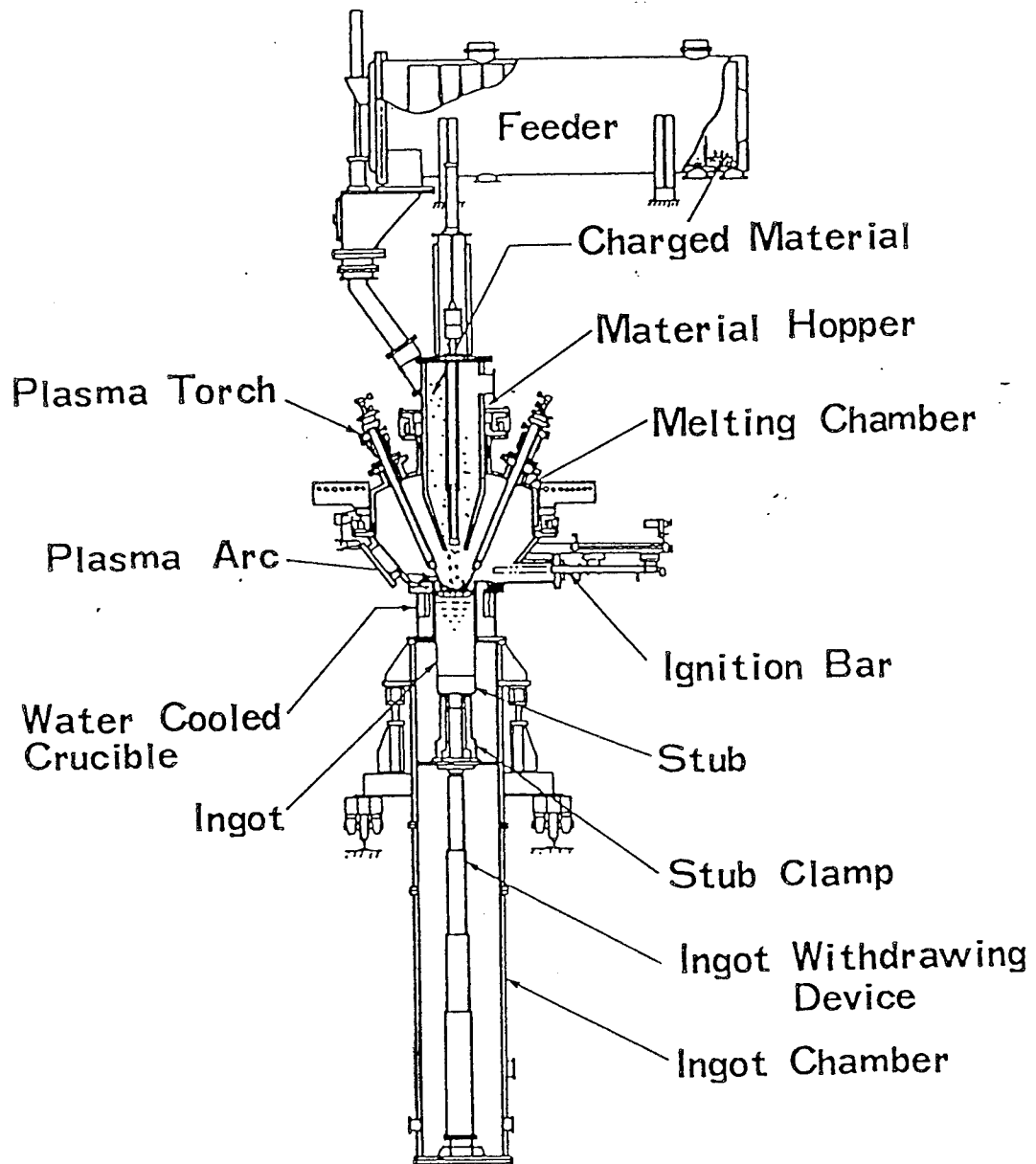

Plasma Torch	6 Torches . Rotating 120°
Plasma Power	540 kW
Atmosphere	Ar (1.0×10^2 kPa = 1atm)
Charging Material	Sponge Ti, Ti and Ti-alloy scrap, Mother-alloy, etc
Ingot Size	435 mm ϕ \times 3000 mm
Ingot Weight	Max ^{1.8 tons} 2000 kg

2. 2 VAP

Total
11 Hr / Heat

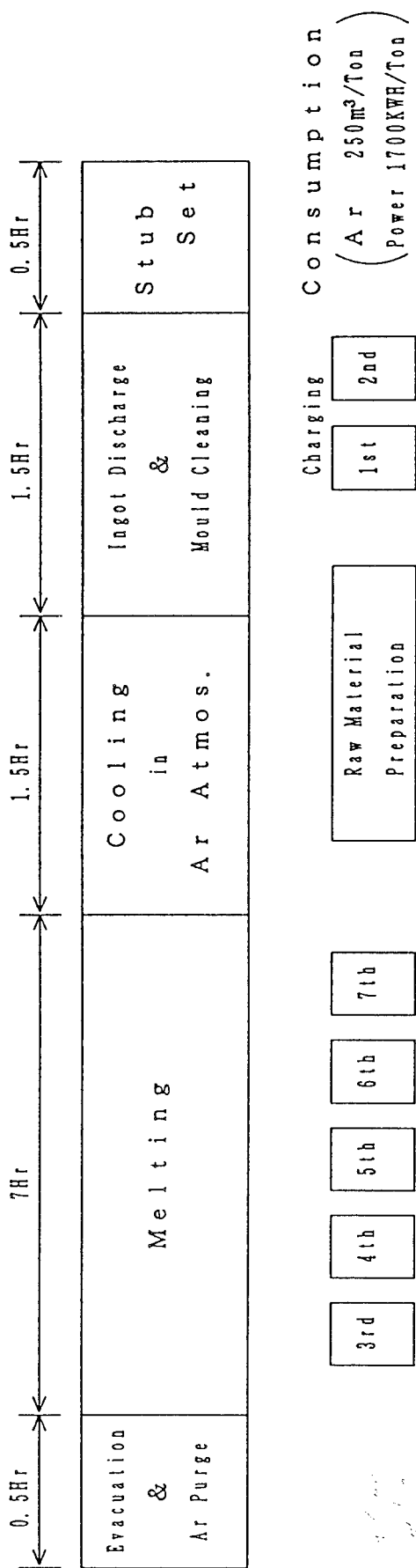

Heat Cycle of PPC Operation

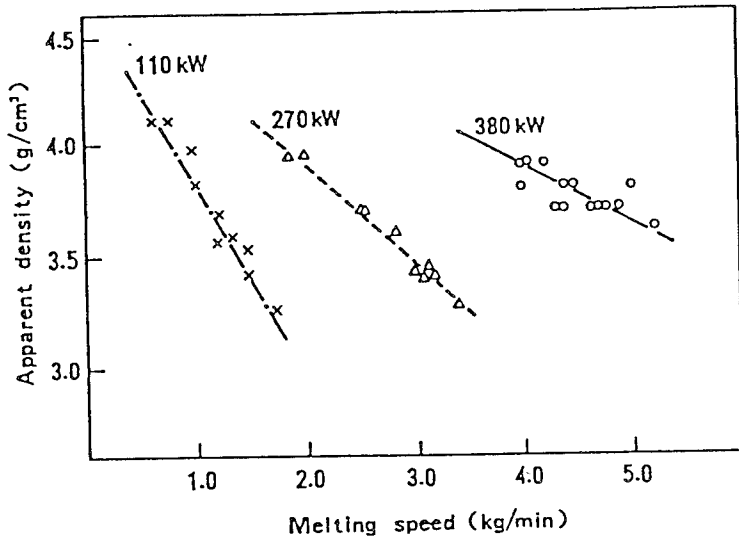

Relation between the melting speed and the ingot density.

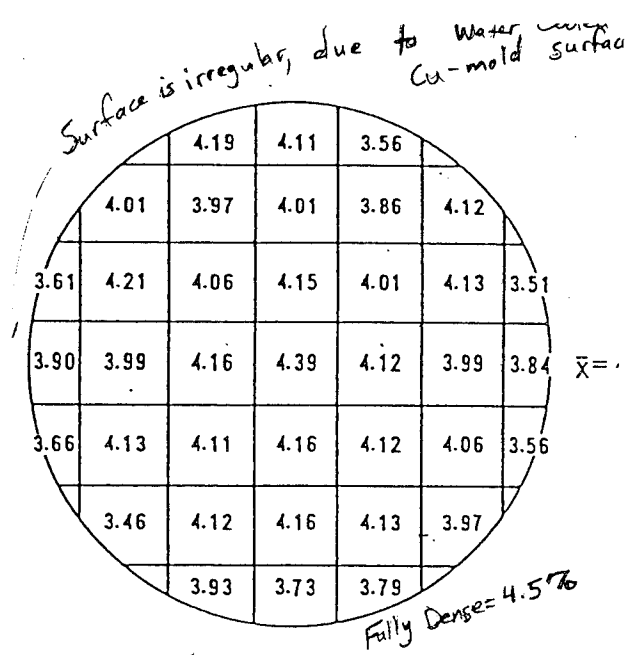

Density distribution of a PPC titanium ingot.
Melting power; 380 kW, Melting speed; 4 kg/min.,
Sponge-Ti ratio; 50%

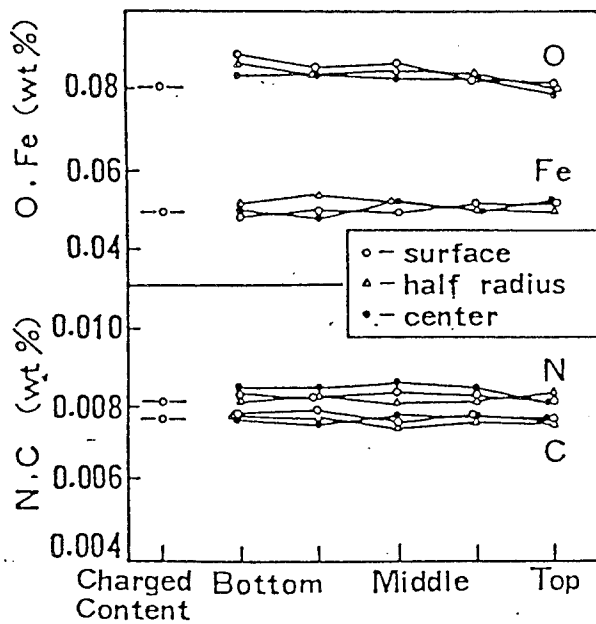

Distribution of chemical compositions in a pure titanium ingot.
Titanium scrap ratio; 50%

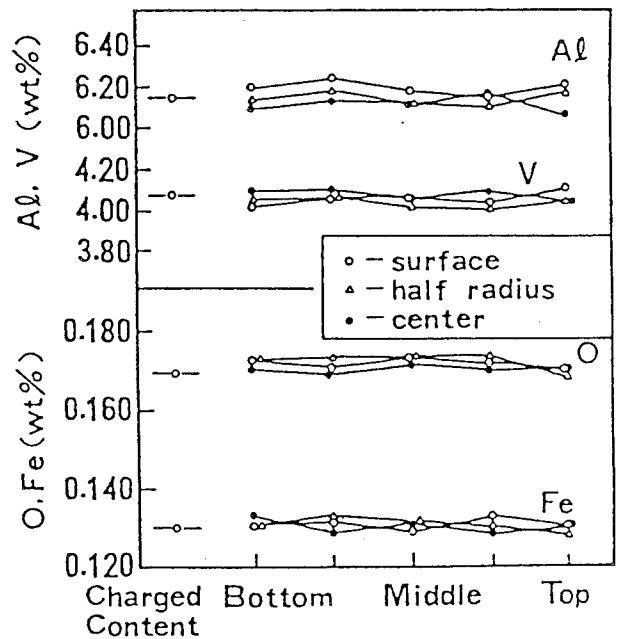

Distribution of the chemical compositions in a Ti-6Al-4V ingot.
Titanium scrap ratio; 50%.

1. 加工法 Working Method

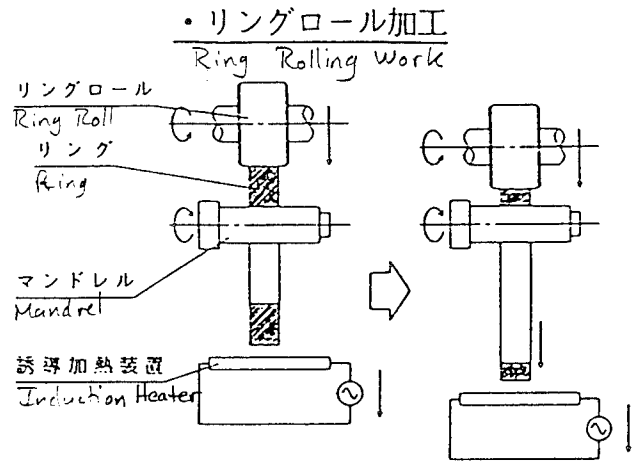
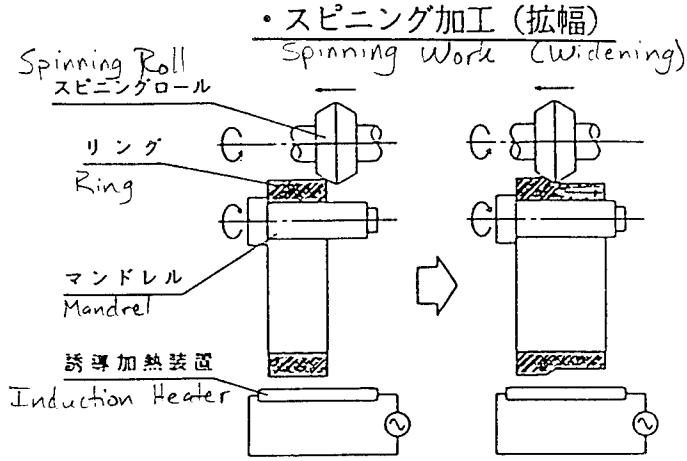

2. 材料仕様 Material Spec.

	母材 Base Material	製品 Product
内径 Inside Dia.	φ200~1600	
幅 width	MAX 150mm	MAX 450mm
肉厚 Thickness	MIN 30mm	MIN 1.5mm
材質 Material	超合金、Ti合金 耐熱鋼、Ni-SUS	

Super Alloys, Ti Alloys, Heat Resistant Steel

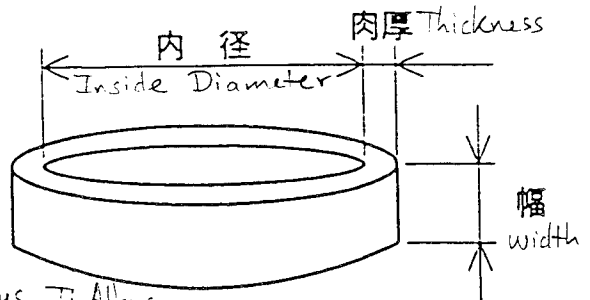

Profile Welding Ring
INCONEL718 : プロファイル溶接リング

3. リング製造プロセス変更
Process Change of Ring Manufacturing

(□は、客先最終形状) Final Form for Customer

	母材 Base Material	リング形状 Ring Form	切削加工等 Cutting	納入形状 Deliverable Form
現 Present State	24tx93Wx1736L 33.4Kg	FBW 93 24 φ508	熱処理 E X P	91 22 φ513 Cutting 15.7Kg/47.
改善 After Improvement	21tx112Wx1736L 34.9Kg	FBW → SRH (スピニング) 112 21 φ508 → 194 21 φ508	熱処理 E X P	88 15 φ515 10.6Kg×2=21.2Kg/60

ng and Rolling - H o t
 (拡 径) (Ti合金等可)

4. 設備概要
 Outline of Installation

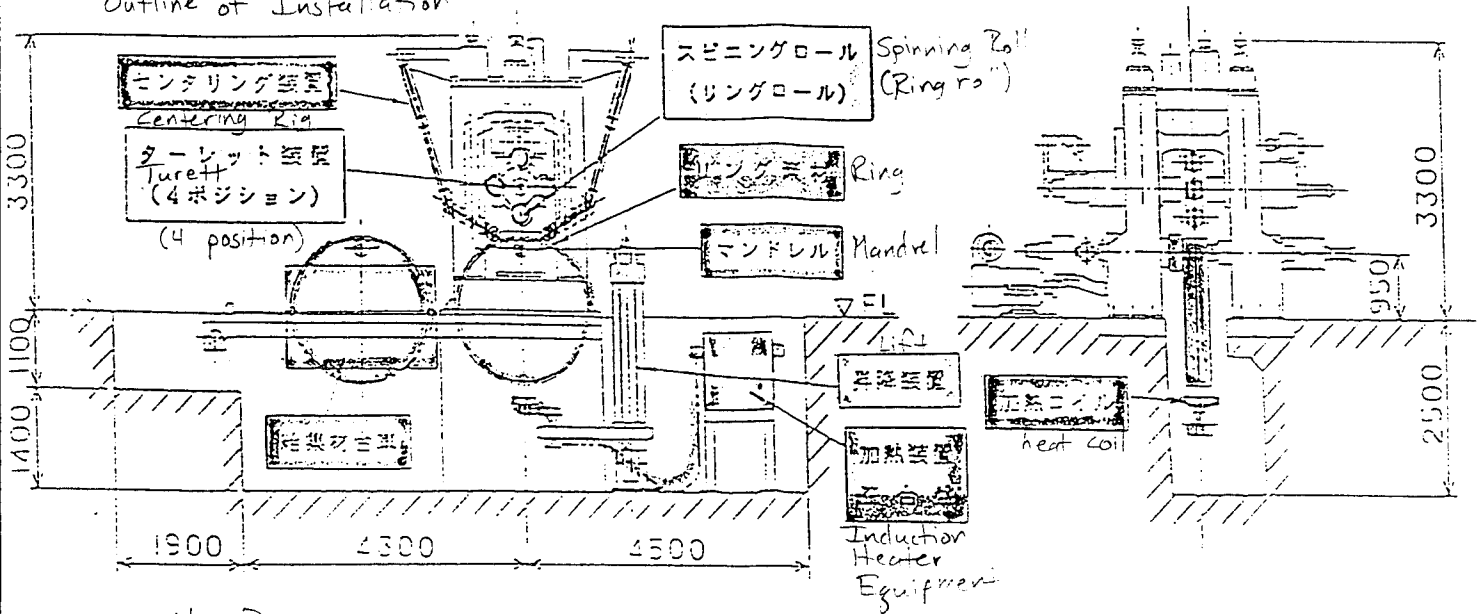

Feeding Power	• 加圧力: 50 Ton	• マンドレル径: $\phi 190\text{mm}$ 、 300mm	Mandrel Diameter
	• 送り力: 35 Ton	• スピニング Spinning Roll Diameter	
Feeding Speed	• 送り速度: 3.0 m/sec	• ロール径: $\phi 350\text{mm}$	
	• 加熱出力: 350 KW	• ワーク重量 : MAX 245 Kg	
Heating Power			

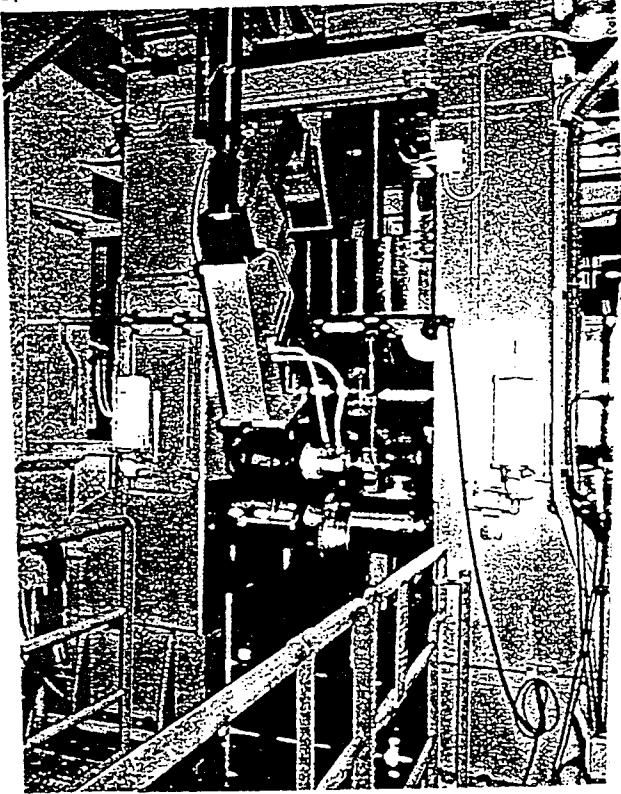

SRH外観
 SRH Appearance

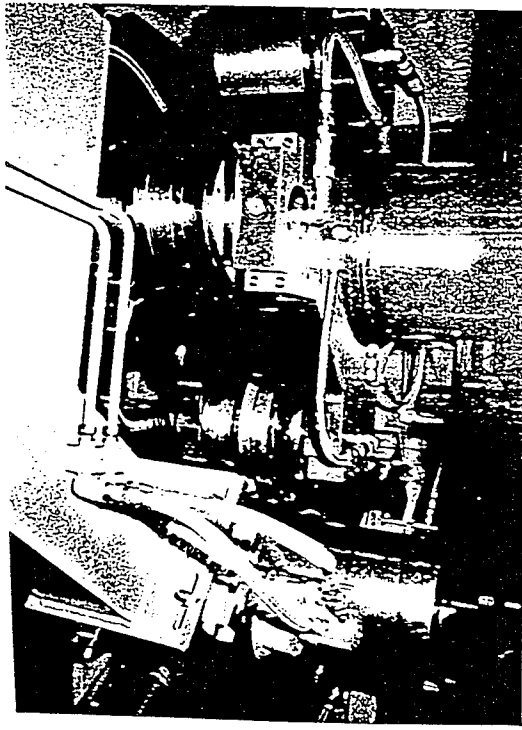

スピニングロール ... 4タレット式ヘッド
 Spinning Roll ... 4 Turret Head