

REPORT DOCUMENTATION PAGE

Form Approved
OMB No. 0704-0188

Public reporting burden for this collection of information is estimated to average 1 hour per response, including the time for reviewing instructions, searching existing data sources, gathering and maintaining the data needed, and completing and reviewing the collection of information. Send comments regarding this burden estimate or any other aspect of this collection of information, including suggestions for reducing the burden, to Washington Headquarters Services, Directorate for Information Operations and Reports, 1215 Jefferson Davis Highway, Suite 1204, Arlington, VA 22202-4302, and to the Office of Management and Budget, Paperwork Reduction Project (0704-0188), Washington, DC 20503.

1. AGENCY USE ONLY (Leave blank) 2. REPORT DATE 3. REPORT TYPE AND DATES COVERED
FINAL

4. TITLE AND SUBTITLE
Nanofabrication of Electronic Devices with the Scanning Tunneling Microscope

5. FUNDING NUMBERS
61102F
2305/GS

6. AUTHOR(S)
Professor de Lozanne

7. PERFORMING ORGANIZATION NAME(S) AND ADDRESS(ES)
Univ of Texas
Austin, TX 78713-1081

8. PERFORMING ORGANIZATION REPORT NUMBER
AFOSR-TR- 95 0160

9. SPONSORING/MONITORING AGENCY NAME(S) AND ADDRESS(ES)
AFOSR/NE
110 Duncan Avenue Suite B115
Bolling AFB DC 20332-0001

10. SPONSORING/MONITORING AGENCY REPORT NUMBER
F49620-93-1-0007

DTIC
SELECTED
MAR 28 1995
SCD

11. SUPPLEMENTARY NOTES

12a. DISTRIBUTION AVAILABILITY STATEMENT
APPROVED FOR PUBLIC RELEASE: DISTRIBUTION UNLIMITED

12b. DISTRIBUTION CODE

13. ABSTRACT

SEE FINAL REPORT ABSTRACT

19950322 154

14. SUBJECT TERMS 15. NUMBER OF PAGES
16. PRICE CODE

17. SECURITY CLASSIFICATION OF REPORT
UNCLASSIFIED

18. SECURITY CLASSIFICATION OF THIS PAGE
UNCLASSIFIED

19. SECURITY CLASSIFICATION OF ABSTRACT
UNCLASSIFIED

20. LIMITATION OF ABSTRACT
UNCLASSIFIED

**Final Technical Report
01 Nov 92 to 31 Oct 94**

**Grant F49620-93-1-0007
PM: Dr. Harold Weinstock
PI: Dr. Alejandro de Lozanne**

This grant represents one year of funding plus a one-year, no-cost extension. The main achievements were:

- 1) Development of a new technique for imaging rapidly with the STM.
- 2) The reproducibility of the writing process was improved dramatically.
- 3) Commercial STM electronics were adapted to our STM.
- 4) Fabrication of the smallest continuous metallic lines to date: 24 nm wide.
- 5) Design and construction of a compact STM for nanofabrication.

These main points are described briefly below and in more detail in the publications listed at the end. Other groups have followed our lead in using the STM to break down precursor gases to make nanoscale deposits, namely Matsui's group at NEC in Tsukuba, Japan, Kent's group at IBM Yorktown (now at New York University), Behm's group in Munchen, Germany, and Nayfeh's group at U. Illinois. This technique is therefore likely to become more important over the next decade.

1) Rapid Imaging with STM

Our idea was to operate the STM in the field emission mode (20-100V) while scanning rapidly over reasonably flat areas. The tip/sample distance is in the order of 10 nm, so that the tip does not crash into the sample even though the feedback loop cannot track all the details of the topography. The image signal is then the emission current, rather than the feedback voltage which is commonly used. STMs have been used in the field emission mode before, but never at such rapid scanning rates (the topographiner developed by Russell et al. operated in field emission, but at a slow scanning rate). Our technique provides enough resolution and contrast to be able to locate metallic contact pads on the surface of silicon with imaging rates that are fast enough to allow real time positioning of the tip over the sample. An example is shown in Figure 1, while more details are given in the previous report and in our published paper.

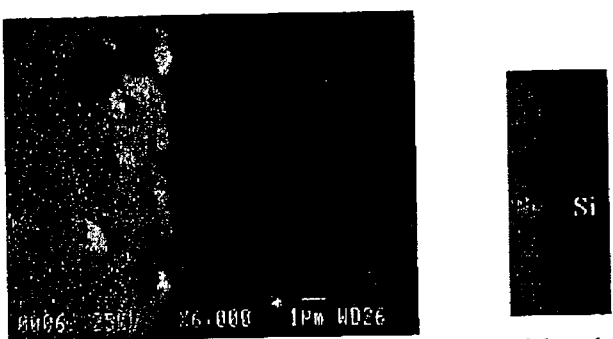

FIGURE 1. Two-dimensional field emission image of the edge of a Pt contact pad. Some of the features along the edge are seen in both the SEM image (left) and STM field emission image (right). The one-micron marker gives the size scale of both images.

Accession For	
NTIS CRA&I	<input checked="" type="checkbox"/>
DTIC TAB	<input type="checkbox"/>
Unannounced	<input type="checkbox"/>
Justification	
By	
Distribution /	
Availability Codes	
Dist	Availability / Special
A-1	

2) The reproducibility of the writing process was improved dramatically.

In the past we had occurrences when the STM was not able to write with the usual gas pressure in the chamber. Out of the many possible causes for this we found that the gas lines have to be bled for a while into the UHV chamber, even though the gas lines were never opened. It seems that there is enough decomposition of the nickel carbonyl at room temperature and that the byproducts (carbon monoxide, most likely) rise to the highest point in the gas lines, where the input to the UHV chamber is located. Once we solved this problem we were able to write with 100% reliability, which has increased our throughput considerably.

3) Commercial STM electronics were adapted to our STM.

Our homemade electronics and software had the main disadvantage that we could not scan large images. Since we installed commercial STM electronics we are able to scan images up to 10 microns on a side and the system is much easier to use. We have lost the ability to modify the software, since this must be done by the vendor, but the present software seems to fulfill our needs for the foreseeable future.

4) Fabrication of the smallest continuous metallic lines.

We made the smallest metallic lines made by any STM, an example is shown in Figure 2. This line was made in our STM/SEM system with nickel carbonyl as a precursor. The width is 24 nm and the height 14 nm. The uniformity in width and height, about 10%, was achieved by repeated scanning over the line during the writing process. This line was 200 nm long, which was not long enough to permit resistance measurements. Longer lines are now being made now with a single pass process.

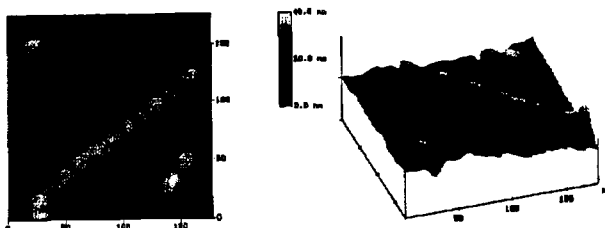

FIGURE 1. STM image of the narrowest nickel line obtained to date: 24 nm wide, 14 nm high and 200 nm long. The smaller dots near the corners are surface contamination. The writing parameters are: 18.7 V, 1.6 nA, and 500 nm/s writing speed.

5) Design and construction of a compact STM for nanofabrication.

To improve throughput and reliability, we have finished a novel design that utilizes a high power optical microscope instead of an SEM. Two key features of this design are a very compact x-y positioner and a custom window welded directly on the side of the chamber. The positioner is built into a standard fine-screw tripod. It provides over 150 μm of orthogonal motion by tilting a 0.25 inch ball bearing that holds a 0.188 inch ball bearing in an off-center position. The two inch sapphire window, which protrudes into the vacuum chamber, makes it possible to have the tip as close as 6 mm to the atmosphere side, as shown in Figure 3. This gives an excellent view of the whole STM and allows us to use a 40x (or 20x) objective lens with a 14 (or 19) mm working distance. The extra distance is important for viewing the sample from different angles, and makes it possible to place the tip over any desired feature on the surface. Figure 4 shows an

example of a large image of the contact pads taken by the STM, after we used the tip positioning system to find this unique location.

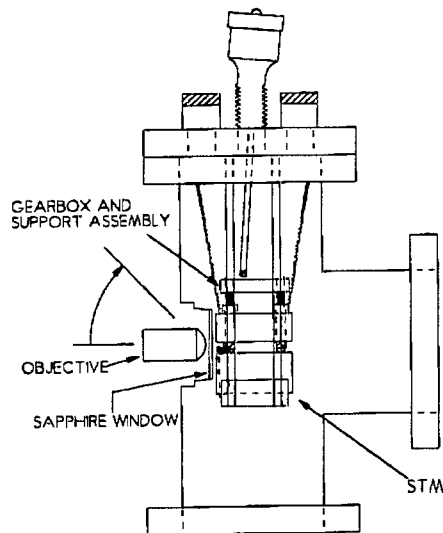

FIGURE 3. Schematic of the new STM chamber, showing the sapphire window laser-welded directly onto its side. The chamber is actually a standard tee with 6 inch flanges and 4 inch tubes. Eight ports with 2.75-inch flanges have been added to the sides (not shown for clarity). The STM hangs from the top flange by very soft springs. A single manipulator on the top turns all the screws (5 of them) and a separate wobble stick (not shown) locks the STM for sample/tip transfers.

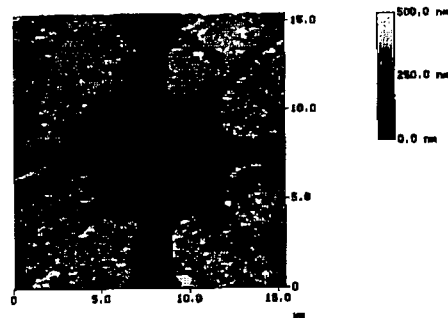

FIGURE 4. Image obtained with the new STM described in the text. This is a unique location, illustrating the capability to position the tip over the contact pads. The image noise is due to poor surface quality, but it demonstrates that we can align the tip with the contact pads.

PUBLICATIONS IN REVIEWED JOURNALS

Rubel, S, Trochet, M, Ehrichs, E, E, Smith, W, S, and de Lozanne, A, L,

"Nanofabrication and Rapid Imaging with a Scanning Tunneling Microscope"

Journal of Vacuum Science and Technology B 12, 1894-1897 (1994).

Rubel, S, Wang, X-D, and de Lozanne, A, L,

"Nanofabrication with a Scanning Tunneling Microscope using Chemical Vapor Deposition"

Journal of Vacuum Science and Technology B , May/June (1995), in press.