

REPORT DOCUMENTATION PAGE

1a. REPORT SECURITY CLASSIFICATION unclassified		1b. RESTRICTIVE MARKINGS	
2a. SECURITY CLASSIFICATION AUTHORITY		3. DISTRIBUTION/AVAILABILITY OF REPORT <i>Approved for public release</i>	
2b. DECLASSIFICATION/DOWNGRADING SCHEDULE		n/a <i>Distribution Unlimited</i>	
4. PERFORMING ORGANIZATION REPORT NUMBER(S)		5. MONITORING ORGANIZATION REPORT NUMBER(S) AFOSR-TR- 95 0126	
6a. NAME OF PERFORMING ORGANIZATION Aerospace & Energetics Research Program	6b. OFFICE SYMBOL (If applicable) FL-10	7a. NAME OF MONITORING ORGANIZATION Air Force Office of Scientific Research	
6c. ADDRESS (City, State and ZIP Code) University of Washington 3935 University Way NE, JM-24 Seattle, WA 98195		7b. ADDRESS (City, State and ZIP Code) Building 410 Bolling Air Force Base DC 20332-6448	
8a. NAME OF FUNDING/SPONSORING ORGANIZATION AFOSR	8b. OFFICE SYMBOL (If applicable) /NE	9. PROCUREMENT INSTRUMENT IDENTIFICATION NUMBER F49620-93-1-0025	
8c. ADDRESS (City, State and ZIP Code) Building 410 Bolling Air Force Base DC 20332-6448		10. SOURCE OF FUNDING NOS.	
11. TITLE (Include Security Classification) (unclassified) DEVELOPMENT OF A TRANSIENT INTERNAL PROBE DIAGNOSTIC		PROGRAM ELEMENT NO. 2301	TASK NO. /ES
12. PERSONAL AUTHOR(S) JARBOE, Thomas R.; MATTICK, Arthur T.			
13a. TYPE OF REPORT final technical report	13b. TIME COVERED FROM 92/10/15 TO 94/10/14	14. DATE OF REPORT (Yr., Mo., Day) 1994 December 16	15. PAGE COUNT 42
16. SUPPLEMENTARY NOTATION n/a			
17. COSATI CODES		18. SUBJECT TERMS (Continue on reverse if necessary and identify by block number)	
FIELD	GROUP	SUB. GR.	transient internal probe; magnetic fusion diagnostic; Verdent material; polarization measurements; 2-stage light gas gun; sabot stripping
19. ABSTRACT (Continue on reverse if necessary and identify by block number) A research effort was carried out to develop and test key components of the transient internal probe, a diagnostic tool for measuring internal magnetic fields in a plasma. A gasdynamic sabot separation method was developed for discarding the sabot upstream of the plasma. Separation is effected in a vented 50-caliber gun barrel, and the sabot is deflected upstream of the plasma, reliably removing the sabot without disrupting the probe trajectory. A vacuum interface was constructed to isolate the plasma from gun gases, which uses a very fast trap-door valve to prevent gas from entering the plasma chamber. A full-up test of the diagnostic was made using a 2.2 km/sec probe to measure a static field in a vacuum. This yielded excellent agreement with Hall probe measurements, with a resolution of 20 Gauss, and the gun gas entering the measurement chamber is to be acceptably small for application to plasma devices.			
20. DISTRIBUTION/AVAILABILITY OF ABSTRACT UNCLASSIFIED/UNLIMITED <input checked="" type="checkbox"/> SAME AS RPT. <input type="checkbox"/> DTIC USERS <input type="checkbox"/>		21. ABSTRACT SECURITY CLASSIFICATION unclassified	
22a. NAME OF RESPONSIBLE INDIVIDUAL JARBOE, Thomas R. <i>Robert Barker</i>		22b. TELEPHONE NUMBER (Include Area Code) 206-685-3427 202-767-5611	22c. OFFICE SYMBOL FL-10 NE

DTIC
SELECTED
 MAR 24 1995
G

TRANSIENT INTERNAL PROBE

SUMMARY

This is a final report on the work carried out on the Transient Internal Probe (TIP) diagnostic experiment under the Air Force Office of Scientific Research Grant # AFOSR F49620-93-1-0025. The period of this work was 10/15/92-10/14/94, which includes a no-cost extension of the original 1-year grant for the period 10/15/93 - 10/14/94.

The TIP diagnostic is a novel method for probing the interior of hot magnetic fusion plasmas that are inaccessible with ordinary stationary probes. In the TIP scheme, a small probe constructed of a magneto-optic material is fired through a hot plasma at high velocity. During its transit the probe is illuminated with polarized laser radiation, which passes through the probe and is retroreflected back to the source by means of a reflector mounted on the probe's back face. In the double pass through the probe, the light's polarization is rotated in proportion to the local magnetic field, and resolution of the polarization angle of the return light by a detection system remote from the plasma allows accurate determination of the magnetic field. In hotter plasmas the probe can be encased in a refractory material, such as diamond, to minimize ablation.

Under this grant research was carried out to develop and test the UW TIP system to the stage where it was ready for installation on the University of Washington Helicity Injected Tokamak (HIT), to be used for measuring the magnetic field profile across the full diameter of the 100 eV plasma. This effort has been successful, and the field measurements on HIT, to be started in January 1995, will be the first high-resolution, local magnetic field measurements ever taken throughout the interior of a high-temperature plasma. The principal accomplishments of this grant were the development of a sabot design and sabot separation method that maintained the integrity of the glass Verdet probe under severe gun acceleration, development of a vacuum interface system for preventing gun gases from entering a test plasma, and the full-up demonstration of the ability to take high resolution magnetic field measurements using a high-speed probe in a vacuum.

Several sabot stripping methods, using integral and segmented sabots, were tested during the grant. Gasdynamic stripping with single-piece sabots proved to be the most effective approach. The sabot is decelerated by a gas ahead of the projectile

19950323 002

producing an axial separation between probe and sabot, and the sabot is deflected and captured upstream of the plasma, allowing the sub-caliber probe to pass freely into the plasma. The gas gun, originally developed under a previous AFOSR grant, was modified to use a larger-bore barrel with an integral sabot separation section. A sabot design was developed which minimizes lateral forces on the probe during acceleration, and maintains the integrity and orientation of the probe and reflector.

A vacuum interface was constructed for capturing most of the gun gases to prevent contamination of the plasma. This consists of a large, evacuated surge tank, isolated from the gun by a diaphragm which is burst by the sabot-separation gas during a shot. A trap-door valve was developed to prevent flow of gun gases in the surge tank into the plasma. This closes very rapidly (under 5 msec) after passage of the TIP probe, and is activated by the sabot breaking a trip wire. High vacuum valves isolate the plasma vessel from the surge tank and probe catch tube prior to a shot.

A mock-up of a plasma chamber, fitted with a static horseshoe magnet, was installed, and probes of FR-5 magneto-optic glass were fired through the chamber at 2.2 km/sec, illuminated by an Argon-ion laser. The magnetic field profile was measured by polarimetry of the retroreflected return light and compared with measurements of the field taken with a Hall probe. The agreement between measurements was excellent, and the observed resolution of the TIP probe was ± 20 Gauss. Pressure measurements in the chamber revealed that the volume of gun gases (mainly helium) entering the chamber was acceptably low (0.4 I-Torr) for HIT plasma. These tests constitute a full-up demonstration of the ability to apply the TIP diagnostic for high-resolution measurements of magnetic fields in high-temperature plasmas.

Accession For	
NTIS CRA&I	<input checked="" type="checkbox"/>
DTIC TAB	<input type="checkbox"/>
Unannounced	<input type="checkbox"/>
Justification _____	
By _____	
Distribution / _____	
Availability Codes	
Dist	Avail and/or Special
	

TABLE OF CONTENTS

1. INTRODUCTION	1
1.1 Background	1
1.2 Research Objectives	4
1.3 Summary of Research Results	4
1.4 Personnel	6
1.5 Publications	7
2. ACCELERATION TESTS AND SABOT STRIPPING	8
2.1 Acceleration Tests and Sabot Design	8
2.2 Sabot Stripping	10
3. VACUUM INTERFACE SYSTEM	24
3.1 Vacuum Interface Design	24
3.2 Trap Door Isolation Valve	25
3.3 Tests of Interface Performance	25
4. B-FIELD MEASUREMENT WITH HIGH-SPEED PROBES	29
4.1 FR-5 Verdet TIP Probes and Sheet Retroreflector	29
4.2 Laser Illumination and Polarimeter	31
4.3 Magnetic Field Measurements	31
5. REFERENCES	37

LIST OF FIGURES

Fig. 1.1	TIP diagnostic layout	3
Fig. 2.1	TIP two-stage light gas gun	11
Fig. 2.2	Photograph of light gas gun	12
Fig. 2.3	Design of 50-caliber sabot and probe	13
Fig. 2.4	Sabot stripping by a constricting obstruction	15
Fig. 2.5	Alternative methods of sabot stripping	16
Fig. 2.6	Photograph of sabot removal using a constriction	17
Fig. 2.7	Photograph of fortuitous gasdynamic sabot separation	21
Fig. 2.8	Sabot separation scheme and vacuum interface design	22
Fig. 2.9	Photographs of probe and separated/deflected sabot	23
Fig. 3.1	Operation of fast-acting trap door valve	26
Fig. 3.2	Pressure history in measurement tank following a shot	28
Fig. 4.1	Laser tracking optics and polarimeter	32
Fig. 4.2	He-Ne laser signal for velocity measurement	34
Fig. 4.3	Signals from polarimeter detectors	35
Fig. 4.4	Magnetic field profile using 2.2 km/sec probe in vacuum	36

TRANSIENT INTERNAL PROBE

T.R. Jarboe and A.T. Mattick
University of Washington

1. INTRODUCTION

This report presents the results of the work performed under Air Force Office of Scientific Research Grant # AFOSR F49620-93-1-0025, to develop a new diagnostic technique, the Transient Internal Probe (TIP), for measuring local magnetic fields in research plasmas. This work was carried out at the University of Washington during the period 10/15/92-10/14/94.

This introduction presents the background motivation for developing this diagnostic, and summarizes the research objectives and accomplishments of the program. The following chapters describe in detail the research carried out on sabot design and sabot stripping, development of vacuum interface, and magnetic field measurement by high-speed probes.

1.1 Background

A critical problem in the study of plasmas is the measurement of local magnetic fields. Although external field measurements can provide global information on current distributions, for example, many of the processes that are pivotal for characterizing plasmas take place at a scale that is orders of magnitude smaller than the plasma dimensions, and are inaccessible with the use of external probes. Local processes involving fluid motion, plasma waves, plasma heating and transport must often be inferred from global information and computer simulation. Knowledge of local fields can provide direct insight into these processes, and internal probes have been used wherever possible to obtain this information. To date, the utility of internal probes has been constrained by materials limitations. The large heat transport to probes in hot plasmas limits probe lifetime, and evaporation of probe material can easily "poison" a plasma by introduction of high-Z material. For this reason, probes are often confined to the cooler, edge regions of a plasma. Transient probing, where probes are

mechanically inserted and withdrawn over periods of 50-100 msec, has been used,[1] but, again, this is usually confined to the plasma edge.

The Transient Internal Probe is a new diagnostic method developed at the University of Washington which minimizes or avoids these problems in the measurement of magnetic fields in hot plasmas.[2-10] The TIP concept, illustrated in Fig. 1.1, makes use of a free-flying probe made of magneto-optic material that traverses a plasma in sub-millisecond time scales, short enough that probe evaporation is minimal or nonexistent. In very hot and dense plasmas the probe can be encased in a diamond enclosure to insure survival. The magneto-optic probe material has the characteristic of rotating the polarization of light in proportion to the local magnetic field. The strength of the field at the instantaneous position of the probe is measured by illuminating the probe with polarized laser radiation, and measuring the angle of polarization rotation in light that returns to a detection system by a retroreflection off of the probe's back face. Communication of field information via visible, narrow-band radiation has advantages of high sensitivity, high bandwidth, and minimal interference by the plasma itself. Detectors can be placed far from the plasma, and can be isolated from the effects of plasma-generating equipment. Relatively common magneto-optic (Verdet) materials exist that allow good field resolution (<40 gauss) using sub-centimeter probe dimensions. The high sensitivity to local fields, and the ability to map out the magnetic field over a plasma diameter in sub-millisecond time scales, represents a breakthrough in plasma diagnostics that will enable direct characterization of plasma processes that have heretofore been difficult or impossible to access.

The understanding of the equilibrium, stability, and transport of a magnetized plasma will be greatly improved by accurate measurement of local fields and their fluctuations. Use of TIP will increase the bandwidth for B-field fluctuations by a factor of 1000 above normal internal probes. However, the primary advantage of TIP is the ability to probe higher temperature and long-lived plasmas: the exposure time of a TIP probe can be 100 times shorter than that of present reciprocating probes, and the exposed area can be 100 times smaller than that of normal probes. The small size of TIP probes makes it feasible to encase them in diamond to enhance the lifetime in hot plasmas. For example, present probing in fusion research is limited to edge plasmas of 50 eV. This new technology would allow measurements in 1.9 keV plasmas.[2] Thus, the internal magnetic fields and their fluctuations could be measured throughout the entire volume of DIII-D (a leading fusion tokamak), not just in the edge. This data is desperately needed by fusion research for understanding stability and transport.

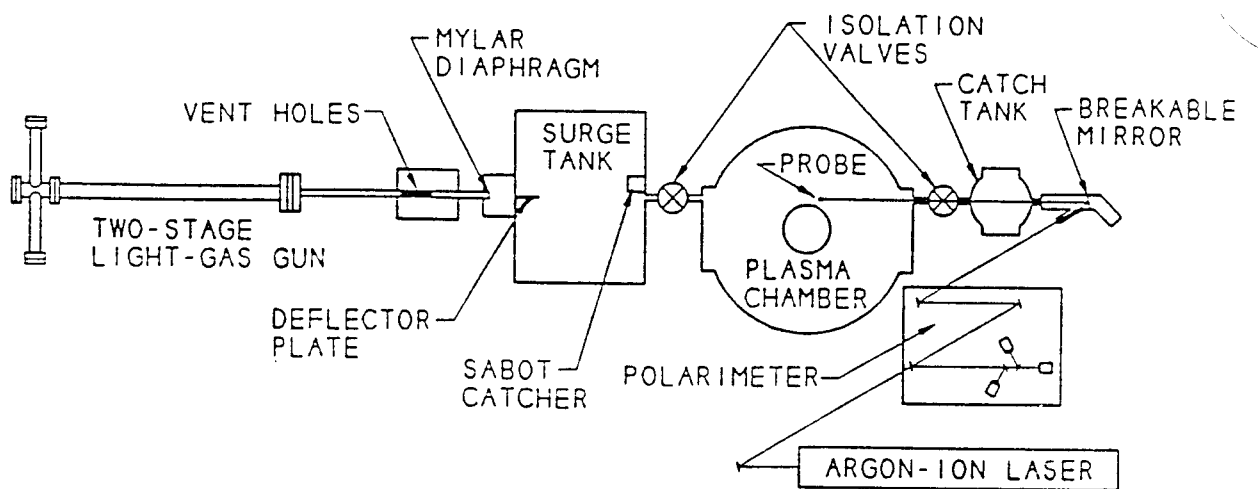

Fig. 1.1 TIP diagnostic layout

Under a previous grant (AFOSR 90-0345) some of the primary components of a TIP diagnostic system were designed and constructed, including a 2-stage light gas gun and a polarimetry system for analysis of the faraday-rotated light from a magneto-optic probe. The gun was extensively tested and proved capable of reliably launching 30-caliber sabots at 3 km/sec. The polarimeter was demonstrated to have a resolution of 0.25° in polarization angle, corresponding to a magnetic field resolution of about 40 gauss, when 10-mm long probes of manganese-doped borosilicate glass (FR-5) illuminated with 628 nm light. Tracking of the probe by the laser and predicted field resolution were verified by dropping probes through a static field and comparing the TIP field measurements with Hall probe measurements. Thus, the feasibility of using this approach for as a magnetic field diagnostic was demonstrated. The aim of the research reported herein was to develop the components needed to apply this system for plasma diagnostics, and to verify the performance of the diagnostic under the conditions of a plasma experiment. This aim has been achieved, and the TIP system is now ready to be installed on the HIT plasma machine at the University.

1.2 Research Objectives

The objectives of this research were to develop key elements of TIP that are necessary for implementation of the diagnostic on research plasmas. These included a method of separating the sabot from the probe without disrupting probe trajectory or orientation and a vacuum interface between the acceleration system and plasma chamber to prevent gun gases from contaminating the plasma. A major objective was to operate the TIP system under conditions required for plasma diagnostics and demonstrate high-resolution magnetic field measurement by a high-speed probe, while keeping the volume of gun gas entering the simulated plasma chamber to an acceptably small value.

1.3 Summary of Research Results

Major accomplishments of the program were development of a reliable method of separating the sabot from the glass Verdet probe without disrupting the probe flight path, construction of a vacuum interface system to isolate a plasma test chamber from gun gases, and a demonstration of high-resolution measurement of magnetic fields by a high-speed probe in a high-vacuum system. The UW TIP system has been validated for diagnostics on research plasmas,

1.3.1 Sabot design and sabot stripping

Several approaches were tried for separating the sabot from the TIP probe, including a tapered constriction, aerodynamic stripping with segmented sabots, and gasdynamic stripping, with technical advice from the Dayton Research Institute. The former two methods, tested with 30-caliber and 45-caliber barrels, were found to either destroy the probe or disrupt its trajectory. To implement gasdynamic stripping, the gun was modified to use a 6-foot long, 50-caliber barrel with vent holes in the midsection to exhaust the gun gas. The aft section of the barrel, prefilled with nitrogen at 1 atm, served as a separator section, and resulted in an axial separation of the sabot and probe separation of several centimeters. The sabot was deflected away from the flight path allowing the probe to pass freely into a test section. This approach, combined with a careful design of the sabot to minimize lateral forces during acceleration, has resulted in an extremely reliable and reproducible system for sabot separation, which preserves the integrity and orientation of the probe.

1.3.2 Development of vacuum interface

A vacuum interface was constructed to isolate the plasma test section from the gun gases and sabot stripping gas. This consists of a 1m³ evacuated surge tank, attached to the muzzle; gas isolation prior to a shot is achieved using a mylar diaphragm which is burst by separation gases prior to arrival of the projectile. A 0.5 inch ID tube provides a passage for the 4mm x 4 mm x 10 mm long probe into a plasma chamber. The gun gas which exhausts into the surge tank is prevented from flowing into the plasma chamber by a specially designed trap door valve which is tripped by the deflected sabot, closing a few milliseconds after passage of the probe. High-vacuum valves further isolate the plasma from the surge tank and probe catch tube, which open shortly before a shot. This interface system is highly effective, and only 0.4 I-Torr of gas is admitted into the plasma chamber during a shot, sufficiently low for operation on the UW HIT plasma.

1.3.3 Magnetic field measurements with high speed probes

A set of magneto-optic probes, 4 mm by 4 mm in cross-section and 10 mm long was obtained for verification tests and application of TIP for plasma measurements. They were fabricated of material similar to Hoya FR-5, but with higher Verdet coefficient, and were individually calibrated using a 2-Tesla magnet facility at the University. A full-up test of the performance of TIP was made by using a high-vacuum

measurement tank to simulate a plasma test section, fitted with a horseshoe magnet to provide a test field. The magnetic field profile measured with a probe travelling at 2.2 km/sec agreed with high accuracy with a Hall probe measurement taken prior to the shot, and the derived resolution of the TIP diagnostic was 26 Gauss. This test validates the ability to apply the diagnostic for high-resolution magnetic field measurement in the interior of a plasma, while limiting influx of gun gas to an acceptable level. The system is ready for installation on the UW HIT plasma.

1.4 Personnel

Professor Tom Jarboe, now of the Department of Aeronautics and Astronautics was the Principal Investigator for the program, with overall responsibility for technical management. Professor Tom Mattick of the Aeronautics and Astronautics Department joined the research team in January 1993 as a faculty investigator, and supervised the experimental program. The construction of the TIP system and experimental testing was carried out by Jim Galambos, a Ph.D. candidate in Nuclear Engineering, and Mike Bohnet, a Ph.D. candidate in Aeronautics and Astronautics, assisted by two undergraduate research assistants.

1.5 Publications

The publications on the TIP diagnostic which were made during the grant period 10/15/92 - 10/14/94 are listed below.

G.G. Spanjers, J.P. Galambos, M.A. Bohnet, and T.R. Jarboe, "Magnetic field measurements using the transient internal probe," presented at the APS Plasma Physics Conference, Seattle, WA, Nov. 16-20, 1992.

J.P. Galambos, "Remote magnetic field measurements using an optically coupled probe," M.S. Thesis, Univ. of Wash., Dept. of Nuclear Engineering, January, 1993.

M.A. Bohnet, "Development of a two-stage light gas gun," M.S. Thesis, Univ. of Wash., Dept. of Aeronautics and Astronautics, June, 1993.

J.P. Galambos, M.A. Bohnet, T.R. Jarboe, and A.T. Mattick, "Development of Transient Internal Probe (TIP) Magnetic Field Diagnostic," APS 35th Annual Plasma Physics Meeting, St. Louis, MO, Nov. 1-5, 1993.

M.A. Bohnet, J.P. Galambos, T.R. Jarboe, A.T. Mattick and G.G. Spanjers, "The transient internal probe: A novel method for measuring internal magnetic field profiles," APS 10th Topical Conference on High Temperature Plasma Diagnostics, Rochester, NY, May 8-12, 1994.

J.P. Galambos, M.A. Bohnet, T.R. Jarboe, and A.T. Mattick, "Development of Transient Internal Probe (TIP) Magnetic Field Diagnostic," 1994 IEEE International Conference on Plasma Science, Santa Fe, NM, June 6-8, 1994.

M.A. Bohnet, J.P. Galambos, T.R. Jarboe, and A.T. Mattick, "Magnetic field measurements at high velocity using a two-stage light-gas gun," 45th Aeroballistic Range Association Meeting, Huntsville, AL, Oct. 10-14, 1994.

2. ACCELERATION TESTS AND SABOT STRIPPING

An essential feature of the TIP system is the use of a sabot to hold the magneto-optic probe during acceleration. Acceleration in the gun requires that the projectile make a seal with the barrel walls. It is not practical to make such a seal between the brittle, glass-like probes and the metallic barrel, as the sliding friction would erode or fracture the probes during acceleration. In addition, the use of a sabot allows flexibility in probe geometry, and it is most economical to fabricate the probes with a square cross-section. A major accomplishment of the research carried out under this grant was the development of sabot designs which maintained probe integrity during acceleration and a system for separating the sabot from the probe prior to injection of the probe into a test section (plasma). Development of a working sabot-stripping scheme required modifications to our light-gas gun in order to accommodate the sabots, and to assure survival of probe and sabot during acceleration. This section describes the gun modifications, and the development of sabot designs and a sabot stripping method.

2.1 Acceleration Tests and Sabot Design

All non-segmented sabots used to date have been fabricated from Lexan, due to its exceptional toughness, light weight, and easy machinability. The sabots hold the probe by means of a circular, flat-bottomed hole drilled in the sabot axis, with a diameter that closely matches the probe's largest cross-sectional dimension. This was done even for square probes because of the difficulty of machining square holes. The development of sabot configurations proceeded by testing various sabot geometries and observing the probe/sabot projectile in flight after emerging from the gun barrel using a high-speed camera. These tests used glass probes, which simulated the physical characteristics of the FR-5 Verdet probes, but were much less expensive.

The primary diagnostic used for all acceleration tests was a high-speed Imacon camera, which records a sequence of sub-microsecond exposures, nominally spaced by 10 μ sec. A detector signal generated from the interruption of a He-Ne laser beam by the projectile and a variable delay was used to trigger the camera. Interruption of a second laser beam allowed determination of projectile speed. The photographs were examined for integrity and orientation of the sabot and probe (when used).

The two-stage light gas gun for accelerating the TIP probes was developed previous to this grant, and is fully described in [6,11]. The configuration reached at the

start of the present work utilized a 30-caliber (7.6 mm ID) barrel and 12.5 mm long Lexan sabots with full caliber OD. This system reliably accelerated the 0.45 gm sabots to 3 km/sec. Circular glass probes were used for testing the ability of Verdet probes to survive acceleration in the gun, with only moderate success.

It was determined that adequate support of the probes required a larger sabot diameter, and early in this grant the gun was modified to utilize a larger, 45-caliber (11.4 mm ID) barrel. The barrel consisted of two sections, each 27.6" long, secured by flanges. Full caliber sabots of length 15.2 mm, weighing 1.4 gm were used for this barrel, and 11-mm long, 4 mm OD circular glass probes were obtained to carry out a series of acceleration tests.

Several problems were identified in the acceleration of circular probes. First, the diametrical tolerance of the glass was $+0.006"$ making fabrication of sabots to fit the probe relatively difficult. The fit of the probe in the sabot was found to be critical to survival of the probe during acceleration. If the hole in the sabot for the probe was machined to the smallest diameter measured for the probe, the fit of the probe in the sabot would be an interference fit in the direction of the largest probe diameter. Approximately 70% of the round probes that had this interference fit were launched completely intact. The other 30% disintegrated during acceleration. No probe/sabot separation was ever achieved with probes that had an interference fit with the sabots. If the hole in the sabot was enlarged to the largest diameter measured on the probe, the probe would fit properly in one direction but would be too loose in the direction on the smallest diameter. Only 10% of these looser probes were successfully launched, and the remainder disintegrated. Probe/Sabot separation was achieved in some of the successful shots, but the separation, when complete, was too little to be of any use.

It was suspected that the most likely cause of probe failure was the use of a 2-section barrel for acceleration. Deviations of the axes of the barrels by only a few thousandths of an inch can cause large lateral accelerations of the probe during acceleration, and the transition between barrels likewise can cause abrupt, and very large probe accelerations. These lateral accelerations can easily cause probe fracture, or set up oscillatory motion that leads to fracture. For this reason, the gun was modified to use a single, 72" long, 50 caliber (12.5 mm ID) barrel to minimize the possibility of lateral projectile motion during acceleration. The larger bore allowed the use of square glass probes, which could be economically fabricated to higher dimensional precision than the circular probes. Although the peak probe speed of 2.2

km/sec is somewhat less than that achievable with the smaller barrel due to the more massive projectile, the speed is sufficient for probe survival in the HIT plasma.

Coincident with installing a larger barrel, the support system for the barrel was improved to allow full support (without relying on support by the pump tube or vacuum chamber at its ends) to minimize barrel sag. The new system facilitates positioning the barrel to align probe trajectory with the diagnostic laser beam to achieve accurate probe tracking. In addition, the breech was redesigned for a more reliable seal of the diaphragm, to insure repeatability of probe speed with given gas fill pressures. A dimensioned figure of the modified gun is shown in Fig. 2.1 and a photograph of the gun is shown in Fig. 2.2.

The use of a single-section barrel and precision square glass probes virtually eliminated probe fracture during acceleration. Fig. 2.3 shows the probe/sabot geometry used for the 50-caliber barrel. The probes have a 4 mm x 4 mm cross-section and are 10 mm long. The square cross-section allowed the probe to be easily custom fit to the hole in the sabot by slightly grinding off the corners of the probe until the diagonal measurements of the probe precisely matched the diameter of the hole in the sabot. In this way the fit between the probe and the sabot could be tailored between the desired sliding fit for gas dynamic sabot separation and the desired support for probe acceleration.

The sabot design evolved from testing several geometries with various depths for the hole holding the probe and configurations for the fore section of the sabot. The critical issue in the sabot geometry is the need to adequately support the probe, while effectively decoupling the probe from the barrel wall, so that any irregularity in the barrel encountered by the sabot is only weakly conveyed to the probe. In the design shown, this is accomplished by shaping the sabot so that the first contact of the sabot and the barrel wall is somewhat aft of the base of the probe. This design also facilitates gas dynamic separation of the probe from the sabot (discussed below).

2.2 Sabot Stripping

Because the sabot material would "poison" the plasmas to which TIP is intended to be applied, the sabot must be separated from the probe prior to the probe's entry into a plasma, and sabot material must be blocked upstream of the plasma chamber. Sabot stripping is an evolving technology as the interest in hypervelocity testing has grown, and the appropriate approach depends on the application. Four approaches for

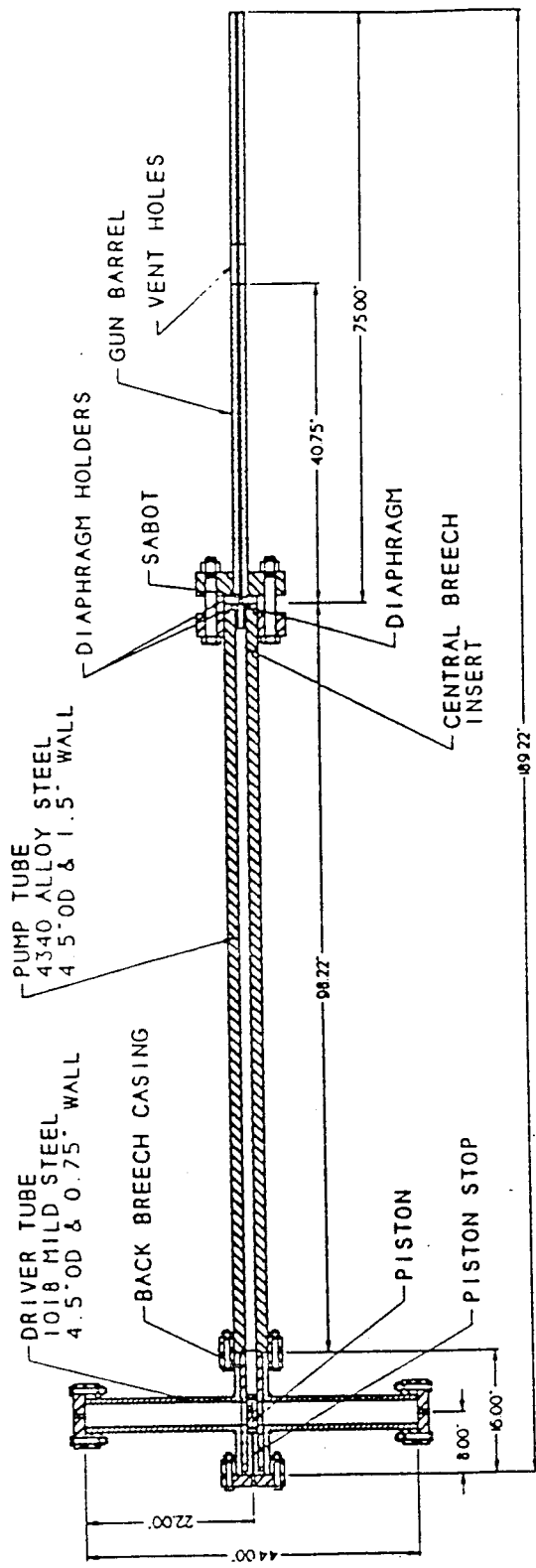

Fig. 2.1 TIP two-stage light gas gun

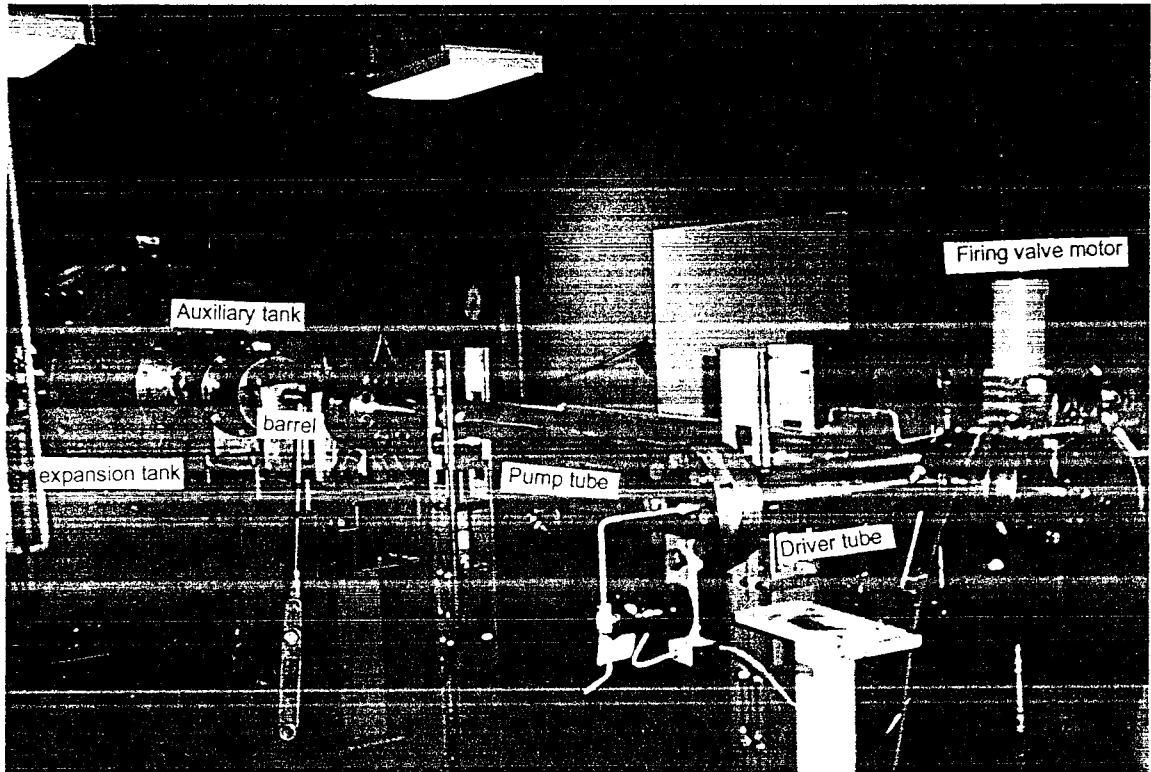

Fig 2 2 Photograph of light gas gun

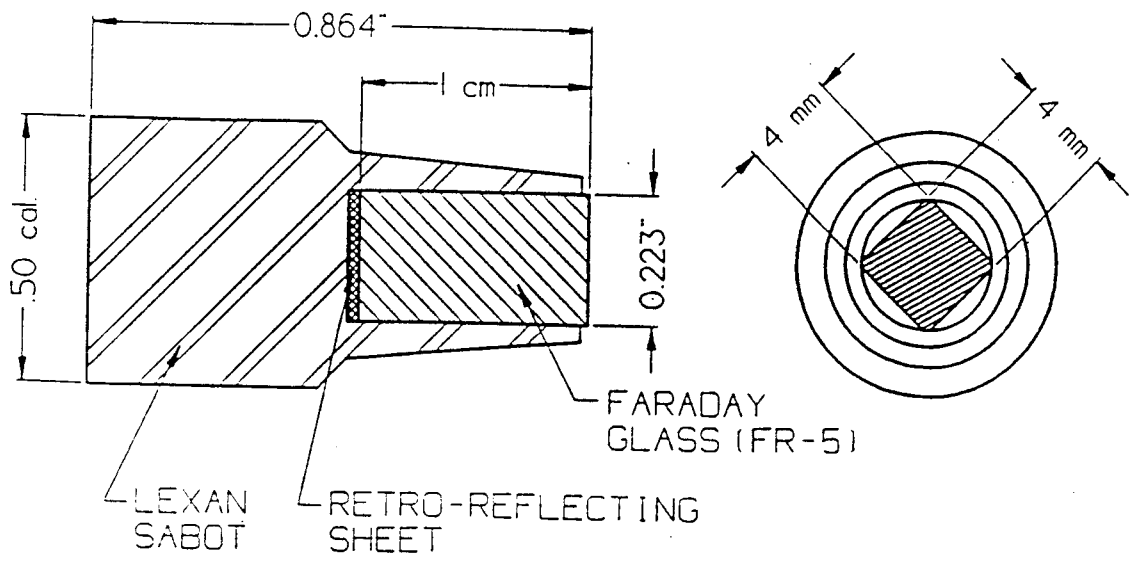

Fig. 2.3 Design of 50-caliber sabot and probe

sabot stripping were examined for use with the TIP system, including mechanical obstruction of the sabot, aerodynamic stripping, spin stripping, and gas dynamic stripping. These are illustrated in Figures 2.4 and 2.5. Each of these approaches is described below.

2.2.1 Stripping by obstruction

In this approach, a constriction is placed in the path of the probe/sabot projectile, which is large enough to allow the probe to pass, but obstructs and stops the sabot (Fig. 2.4). Although this is probably the simplest scheme to implement, experience has shown that it is very difficult to prevent destruction of the probe with this approach, because of shock waves generated by impact of the sabot on the obstruction. In addition, at the high projectile speeds used, the sabot will disintegrate into small pieces which can pass through the constriction and enter the plasma. These problems were encountered in a series of tests which were carried out, in which a gradually tapered constriction was attached to the end of the gun to obstruct the sabot. None of these tests proved successful, as the probe was found to disintegrate due to the shocks conveyed to the probe on impact. Figure 2.6 shows a photograph of the probe material issuing from the gun for this configuration. The probe has clearly disintegrated. Because of this difficulty, alternative stripping methods were pursued.

2.2.2 Aerodynamic and spin stripping

Aerodynamic and spin stripping (Figures 2.5a, 2.5b) utilize a segmented sabot which is held as a single piece during acceleration by the barrel walls, but which disassembles radially from the probe after emergence from the barrel by radial aerodynamic and centrifugal forces, respectively. These approaches require that the sabot segments have a serrated interface to minimize shear and gas leakage through the interface during acceleration. Samples of 50-caliber, segmented sabots, fabricated from Ultim, were obtained from the Dayton Research Institute for testing with our gas gun.

For aerodynamic separation, the front face of the (assembled) probe is machined with a concave conical taper. By passing the sabot/probe through a stripping gas exterior to the muzzle, a radial aerodynamic force is imparted to the sabot segments, causing them to fly apart. Spin stripping utilizes a rifled barrel to impart an angular rotation to the sabot/probe. Centrifugal force causes the sabot segments to fly apart radially when the projectile emerges from the tube. The radial speed v depends

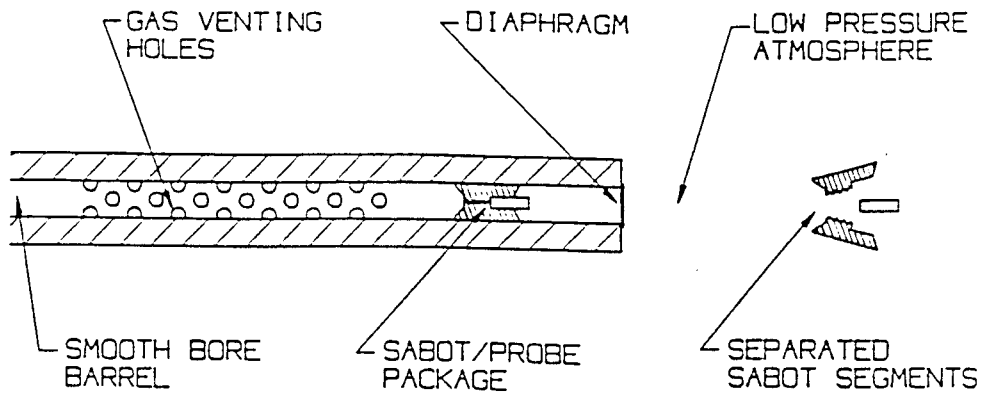

a) Aerodynamic stripping. Sabot is separated radially by aerodynamic forces.

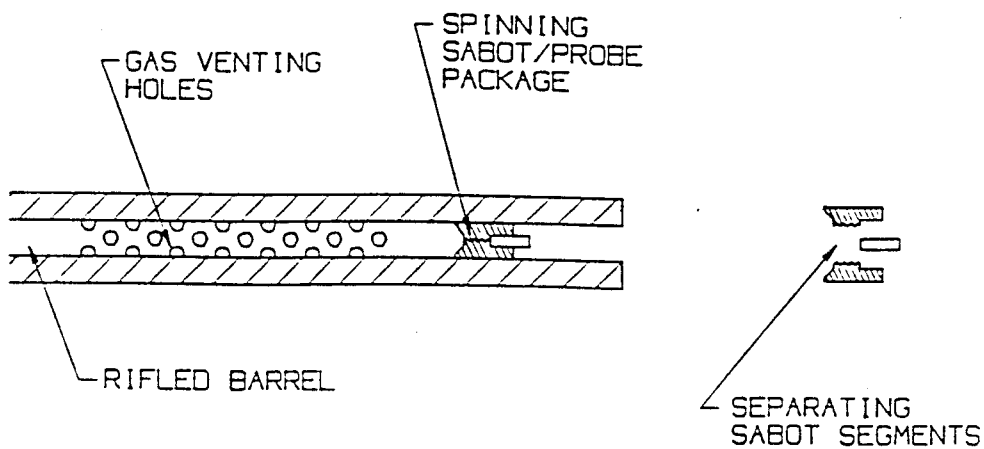

b) Spin stripping. Spin from barrel rifling causes separation via centrifugal force.

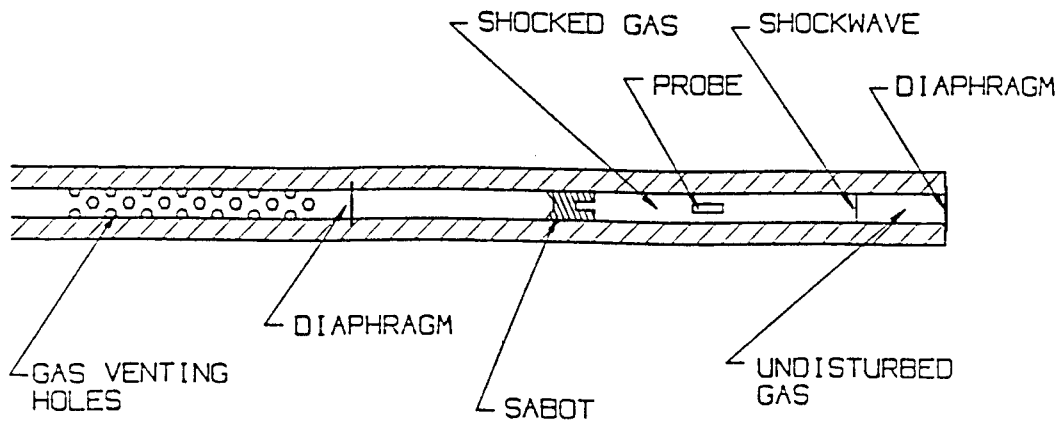

c) Gasdynamic stripping. Sabot is decelerated via high-pressure, shocked gas downstream. Upstream gun gas is vented.

Fig. 2.5 Alternative methods of sabot stripping

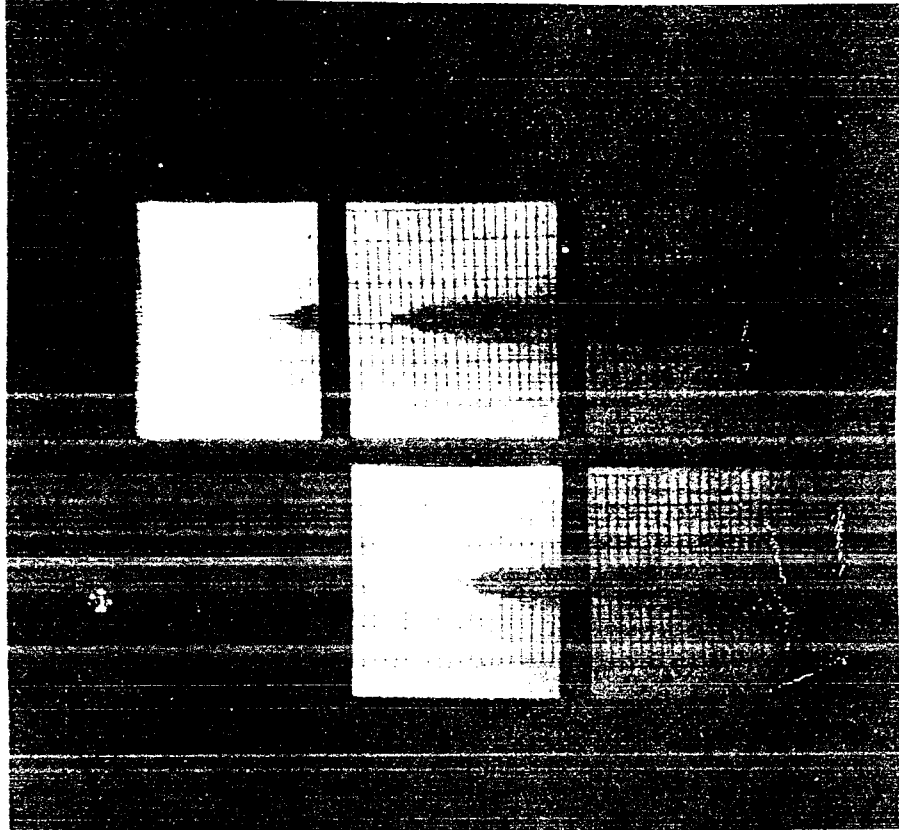

Fig. 2.6 Photograph of attempted sabot removal using a constriction. Probe disintegrates due to impact shock waves.

on the axial speed u , rifling pitch L , and sabot radius r via $v=8ur/3L$. Thus, for example, at a distance of 1 m downstream of a 30-caliber barrel having a rifling pitch of 1 meter, the segments will have moved about 2 cm from the projectile axis.

For both of these approaches the sabot segments can be prevented from entering the plasma by placing an obstruction in the path which has a small hole to allow passage of the probe. In addition, the system can be designed so that cratering of the obstruction by the sabot can swage the probe hole shut, to prevent passage of gas into the plasma test region. This scheme has been successfully implemented at PAI.[12]

A series of tests were carried out to assess the feasibility of aerodynamic stripping with segmented sabots. Concave faces were machined onto the leading faces of the sabots, to effect aerodynamic separation, although machining the segmented system proved difficult. High-speed photographs of the sabots emerging from the muzzle showed that they consistently fractured into several pieces, either during acceleration, or in the process of separation. Although rifled barrels had been obtained for the purpose of testing spin-stripping, these were not used because of the failure of the radial-stripping approach using aerodynamic forces.

Although these approaches have been successfully implemented in ballistics research they have drawbacks for the TIP diagnostic. Aerodynamic stripping requires the presence of a large volume gas between the gun and the plasma. This gas must be not be allowed to enter the very low pressure plasma chamber, and isolation poses a difficult problem. Spin stripping imparts a rotation to the probe. While this has the potential benefit of stabilizing the probe axis, it makes future extension of the TIP diagnostic to measurement of field components transverse to the direction of motion difficult, since the probe orientation must be accurately known to measure these transverse fields. In addition, it was determined that for square probes, there will always be interference between the edges of the sabot segments and the probe during separation; this rules out the use of square probes, which also makes extension of the diagnostic to transverse fields problematic. For these reasons, and because of the observed fracturing of aerodynamic probes in preliminary tests, our efforts focused primarily on the use of gas dynamic stripping described below.

2.2.3 Gasdynamic stripping

In gas-dynamic stripping (Figure 2.5c), the barrel is initially filled with a separator gas, and vent holes are present in the mid part of the barrel. Once the projectile passes by the vent holes, the high-pressure pump gas (helium) driving the projectile forward is released through the holes, and the pressure behind the projectile falls rapidly. The supersonic speed of the projectile with respect to separator gas causes a shock wave to build up ahead of the projectile, which "swallows" an increasing volume of gas, pressurized to roughly:

$$P_s \approx P_o \frac{2Mu^2}{\gamma RT},$$

where M is the molecular weight, γ is the specific heat ratio and P_o and T are the initial pressure and temperature of the separator gas, R is the universal gas constant, and u is the projectile speed. Since the pump gas has been vented, the high-pressure slug of shocked separator gas ahead of the projectile causes a net backward force and a deceleration of the sabot. However, since there is no seal between the probe and sabot, the separator gas exerts equal pressure on all sides of the probe, so there is no net force on the probe. For this method of stripping, the sabot is machined to hold the probe with a loose fit. Thus the sabot drifts backward from the probe in the separator tube, accomplishing axial separation. Using nitrogen at atmospheric pressure as a separator gas, a 1-gram sabot emerging from the gun barrel at 3 km/sec will experience a deceleration of roughly 60,000 g in the separator, resulting in a separation distance of about 4 cm in a 1-m long separator tube. An analogous gas dynamic stripping method has been successfully implemented in the RAM Accelerator facility at our laboratory.[13]

A particular advantage of this approach is that the pump gas is largely dissipated by the vent holes by the time the probe reaches the muzzle, and this reduces muzzle blast and the consequent disruption of probe orientation and trajectory as it emerges from the gun. The radial stripping schemes discussed above require that vent holes be placed near the muzzle end to minimize blast.

In the experiments carried out with the 45-caliber barrel it was often observed that the probe had separated from the sabot, without having implemented dedicated sabot-stripping hardware. The most likely reason for this is that gas dynamic stripping was taking place in the downstream section of the compound barrel, as the pressure of the pump gas decreased via simple expansion. In these tests the projectile was fired into room air, and a shocked, high-pressure slug of gas built up ahead of the projectile

naturally, during acceleration in the barrel. The photographs in Fig. 2.7 of the projectile fired into room air show that the probe separated from the sabot by about 0.5 cm at a distance 70 cm downstream of the barrel exit. For these tests, using circular glass probes, the sabot was machined for a "loose" fit of the probe (the probe can be easily inserted and withdrawn from the probe manually). Based on these promising results, it was decided to pursue gas dynamic stripping as the primary approach for sabot stripping for TIP.

Figure 2.8 shows the gas dynamic sabot stripping design developed for the TIP gun which has proved successful. The vent holes in the barrel vent the high pressure helium into a 0.027 m³ tank sealed by O-rings to the barrel outer wall. The tank is initially filled with nitrogen at 1 atm, which serves as the separator gas in the barrel. The end of the barrel is sealed with a thin (.0005") sheet of mylar, isolating the separator gas from the evacuated surge tank attached to the muzzle of the gun by a sliding O-ring seal. The surge tank serves to prevent the pump and separator gases from entering the plasma chamber downstream, as described in section 3.

To prevent the sabot (or pieces of it) from entering the plasma, it is deflected by a plate mounted at a shallow angle (plate face is inclined 3 ° from projectile axis) near the entrance of the surge tank. The plate is positioned to allow the probe to freely pass, but obstructs the sabot, deflecting it to a trajectory nominally 2 ° from the probe axis. The degree of contact and angle of deflection are minimized in order to prevent disintegration of the sabot, and possible entry of sabot material into the plasma. The deflected sabot is directed to a "catch tube" mounted on the downstream face of the surge tank. The sabot disintegrates on impact with a replaceable aluminum plate at the back of the catch tube, and the tube is designed to capture as much sabot debris as possible, in order to help maintain the vacuum integrity of the surge tank. After traversing the surge tank, the probe passes through a 0.5 inch ID, 12 inch long tube, isolated by special fast-acting valves, into the plasma chamber.

This design has been 100% successful for sabot separation, and the probe trajectory and orientation following separation has been found to lie on the barrel axis with high precision. Figure 2.9 shows high speed photographs of the probe and sabot taken at a point 1 m downstream of the muzzle, in the surge tank. It shows a stable probe traveling at 2.2 km/sec followed by the separated and deflected sabot. The 3 cm separation distance observed in the photograph is typical, and the deflection of the sabot is very reproducible.

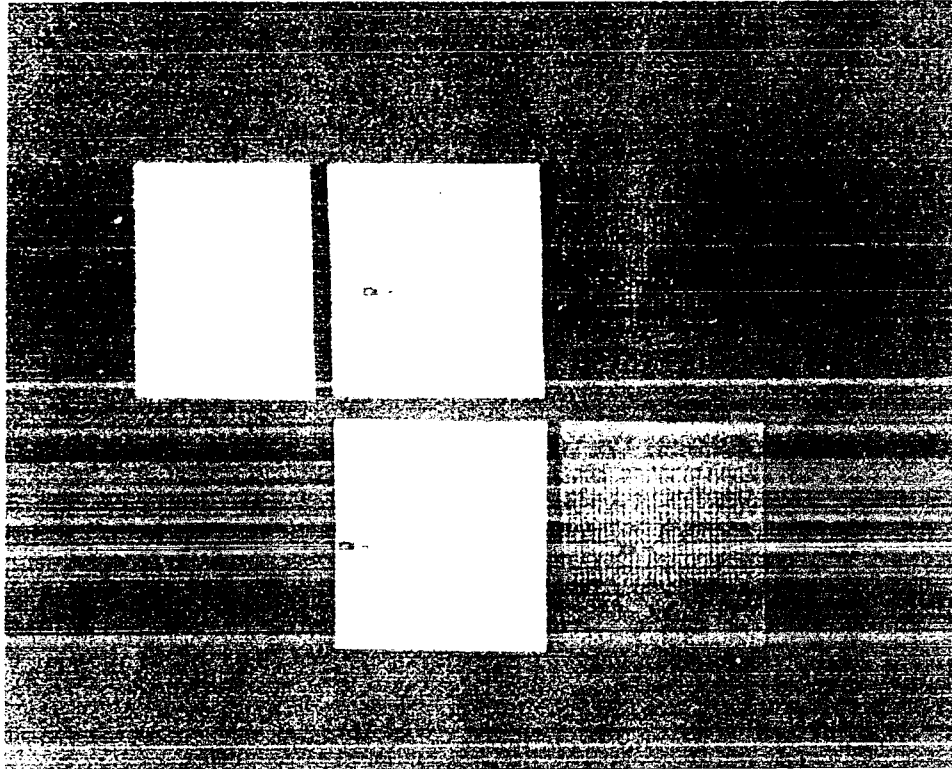

Fig 2.7 Photograph of fortuitous sabot separation with 45-caliber barrel.
No dedicated separation hardware has been used.

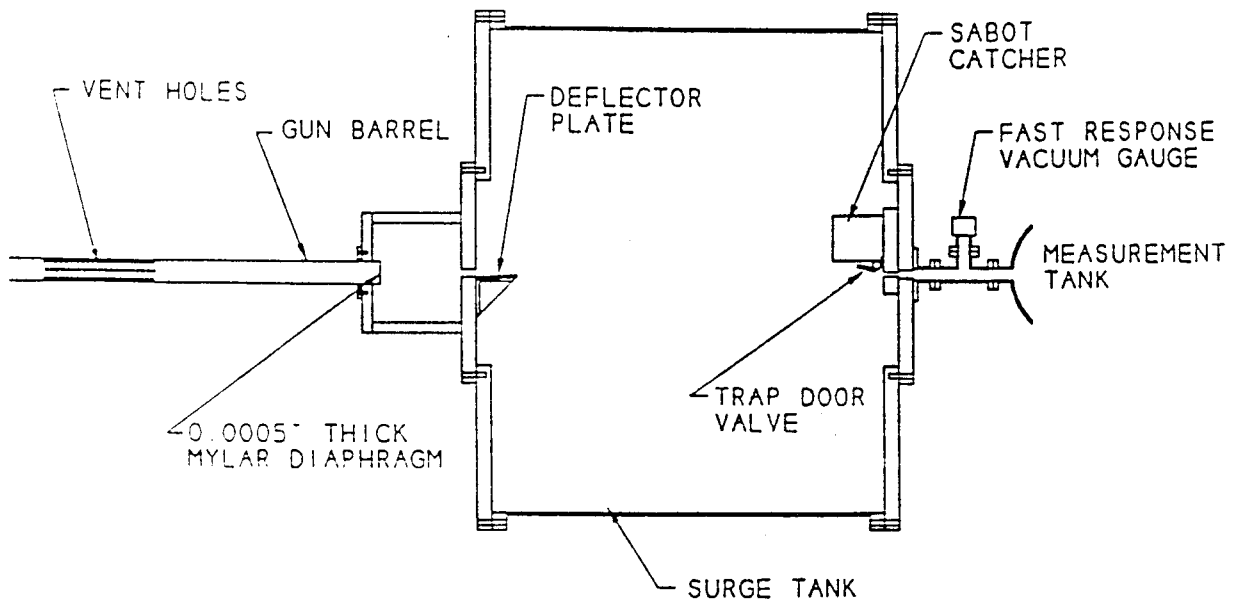

Fig. 2.8 Sabot separation scheme and vacuum interface design.

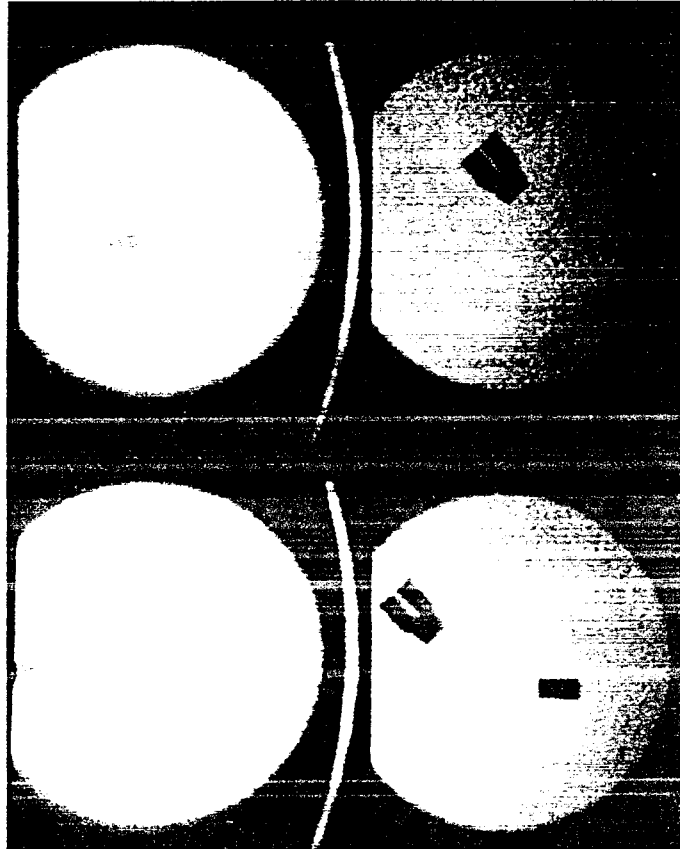

Fig. 2.9 Photographs of probe and separated/deflected sabot travelling at 2.2 km/sec.
Motion is from left to right. Time between frames is 10 μ sec.

3. VACUUM INTERFACE SYSTEM

The use of TIP as a diagnostic for plasmas requires careful design of a system to isolate the gases used for probe acceleration and sabot separation from the low pressure (typically 10^{-8} Torr) plasma test chamber. These gases can easily "poison" the plasma by introduction of high-Z material. Although the helium used as a pump gas in the TIP light-gas gun is not too detrimental to the plasma, there is inevitable erosion of the gun components and the sabot which contains high-Z species and is carried along by the gun gases. Isolation is particularly difficult because of the initial high pressure and high speed of the gun gases. In the course of this grant, an isolation system has been designed and constructed which fulfills the requirements of isolation for the helicity-injected tokamak (HIT) plasma, on which the TIP diagnostic will be tested in the near future.

3.1 Vacuum Interface Design

Figure 2.8 of the previous section shows a schematic of the vacuum interface system that has been developed. The primary element of the system is a large (1.2-m diameter, 1-m long) surge tank which collects the gun gases. The muzzle of the gun is interfaced to this surge tank via a 0.0102 m^3 exhaust volume, which is sealed to the barrel via a sliding O-ring. The exhaust volume is attached to the upstream end of the surge tank and has a 0.75" ID passage for the probe and sabot (separated as they emerge from the muzzle). The surge tank and connected exhaust volume are pumped to a nominal pressure of 10^{-6} Torr prior to a shot, using a 300 l/sec turbopump. As the barrel serves also as a separation tube for axially separating the sabot from the probe, it must be prefilled with nitrogen to a nominal pressure of 1 atm, and thus must be isolated from the evacuated surge tank prior to a shot. This is accomplished using a 0.0005" thick film of mylar, sealed to the end of the barrel. The mylar is broken by the shocked gas ahead of the projectile, and thus does not contact the leading optical surface of the TIP Verdet probe.

The surge tank must also be isolated from the plasma experiment prior to a run, since it is impractical to maintain the same degree of vacuum and purity in the surge tank as in the plasma test section. This is accomplished by using a high-vacuum valve (valve 1) in the tube connecting the surge tank and the plasma tank. As described in Section 2 the sabot is deflected by a deflector plate and is caught in a catch tube in the surge tank, while the probe passes into the connecting tube. Valve 1, placed in this connecting tube, is normally closed, and is opened (connecting surge tank and plasma

tank) about 1 second prior to firing the gun. The impedance of the connecting tube prevents appreciable flow of surge tank residual gases to the plasma tank prior to arrival of the probe. The probe passes through the connecting tube (and valve 1 opening) into the plasma tank.

3.2 Trap Door Isolation Valve

Exhaust of gun gases into the large surge tank causes the surge tank pressure to rise to nominally 10 Torr following a firing of the gun. This gas must be prevented from flowing into the plasma. Although in theory, this could be accomplished by closing valve 1, a valve with the required closing time and having an opening diameter large enough to accommodate the probe would be prohibitively expensive. For this reason, an inexpensive "trap-door" valve was designed for isolation, which closes very rapidly following passage of the probe into the connection tube.

The operation of the trap-door valve is illustrated in Fig. 3.1. This valve is comprised of an aluminum flap of mass 5.5 gm, mounted to the back side of the surge tank by a pivot rod, and tensioned by a coiled spring. The flap is held open by a thin wire which passes through the center of the sabot catch tube, and the torque in the open position is 120 Nt-cm. The sabot breaks the wire, causing the flap to close against an O-ring seal. Use of the sabot to trigger valve provides a simple, passive timing mechanism; it is exceptionally reproducible and foolproof, since the sabot lags the probe very reliably by nominally 3 cm at the valve's axial location. While this simple valve does not make a high-vacuum seal, it does greatly reduce gas flow into the plasma. Although the flow of gun gases into the surge tank is directed along the probe trajectory, the probe outruns the bulk of the gas flow, and the closing of the trap door valve occurs in a short enough time (4.5 msec) to prevent most of the directed flow from entering the connection tube.

3.3 Tests of Interface Performance

The performance of this vacuum interface was tested using a sub scale mock-up of a plasma chamber ("measurement tank"). The measurement tank volume (50 l) is 20 times smaller than the HIT plasma chamber for which the TIP diagnostic will be first applied. The pressure rise in this tank due to leakage of gun gases will be larger than that expected in the plasma tank by the same factor, and thus affords a very sensitive test of the performance of the vacuum interface. The measurement tank and associated plumbing and valving were constructed of stainless steel, of high vacuum

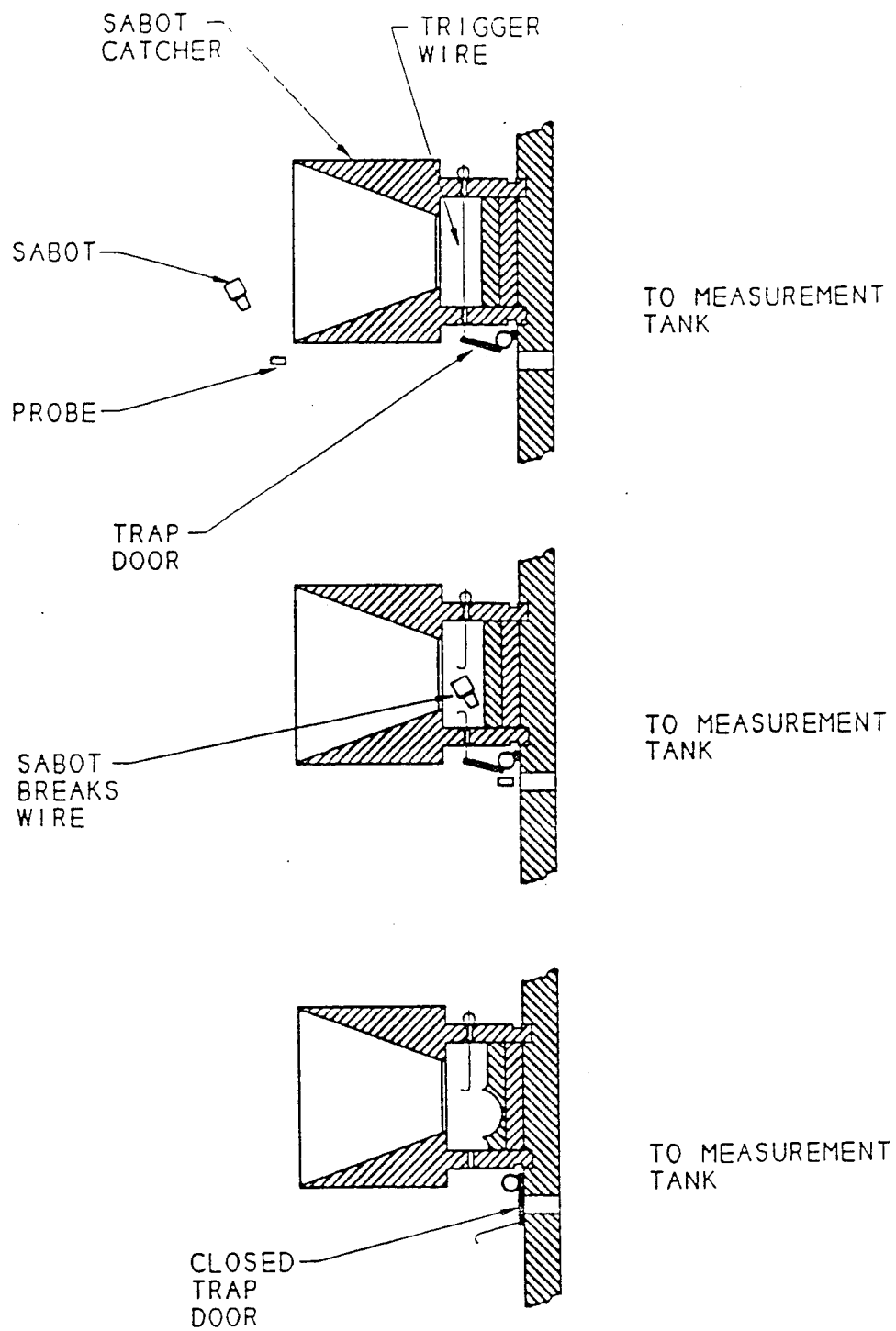

Fig. 3.1 Operation of fast-acting trap door valve.

quality. A 150 l/sec turbopump was used to evacuate this system to pressures of nominally 10^{-6} Torr, to approximate the characteristics of a plasma chamber. The system is fitted with an ion pressure gauge and thermocouple gauges for sensitive pressure measurement over a wide range of pressures.

The probe passes through the measurement tank and into a catch tube that has an angled end section to minimize dispersal of the debris from the probe when it disintegrates. This tube is isolated from the measurement tank by a fast-acting valve, with ID sufficient to pass the probe, that is opened shortly before a shot. The catch tube contains a breakable mirror to direct the diagnostic laser beam down the axis of the experiment, and a side tube with an optical port to admit the laser beam and collect the reflected light from the probe as it traverses the system. The catch tube system is also constructed from stainless steel with high-vacuum rated fittings. The same tube will be used for the actual plasma measurements.

The vacuum interface was tested to determine amount of gas entering the measurement tank during a shot. A hard vacuum was not required for this test, and the system was rough pumped to a starting pressure of 37 mTorr. Figure 3.2 shows a trace of the pressure history in the measurement tank during a shot. These measurements were taken using a fast-acting vacuum diaphragm gauge with a response time of under 1 msec. There is a sharp pressure rise to about 145 mTorr immediately following entrance of the probe into the tank, after which the pressure relaxes back to a steady value of 45 mTorr. The high-frequency component of the signal is due to acoustical vibrations coupled through the walls of the surge tank and fittings. The net pressure rise of 8 mTorr in the measurement tank corresponds to admission of approximately 0.4 Torr-l of gun gases, or about .003% of the total amount of gun gases. For the HIT plasma chamber, having a volume of 1 m^3 , the pressure rise would be about 0.4 mTorr, an acceptable level for this plasma. Thus the vacuum interface system and trap-door valve have been demonstrated to effectively isolate the gun gases from the test section, and can be used with confidence for an actual plasma diagnostic.

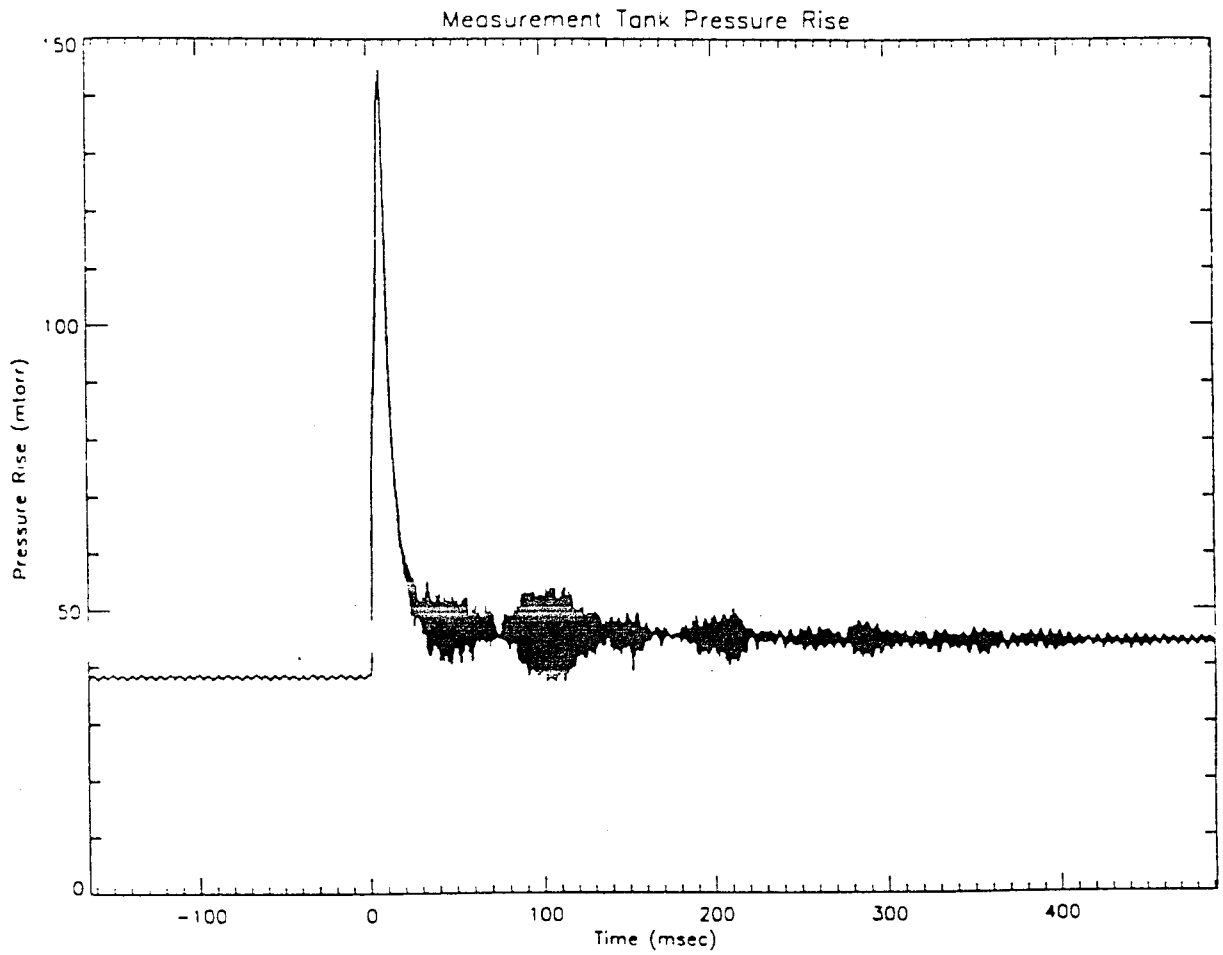

Fig. 3.2 Pressure history in measurement tank following a shot.
Net pressure rise is 8 mTorr.

4. B-FIELD MEASUREMENT WITH HIGH-SPEED PROBES

Previous work on the TIP diagnostic had demonstrated the ability to measure magnetic fields with a moving Verdet probe, by dropping a probe through a static field and measuring the polarization change of retroreflected light.[8,11] The measured field profile agreed well with that obtained using a Hall probe. While that work was important in demonstrating the field resolution of the diagnostic and the performance of the polarimetry system, it remained to be seen whether the system would function as intended when the probes were accelerated to high speed in a vacuum tight system, i.e., the conditions which must be met for application of TIP for B-field measurements in plasmas. At issue is the survivability of the probe and retroreflecting element under extreme acceleration, the maintenance of correct probe attitude and trajectory to allow tracking by the laser beam, and the ability to prevent the acceleration system (gas gun and sabot) from introducing excessive contamination into the plasma.

An important milestone accomplished in this grant is the full-up demonstration of the ability to accurately measure magnetic fields using a high-speed Verdet probe in an evacuated test chamber. The demonstration of vacuum integrity of the test chamber was discussed in Section 3. In this section, we present the results of the successful, high resolution measurements of a magnetic field by a high-speed probe in a vacuum test chamber, along with work carried out in development of improved Verdet probes and polarimetry diagnostics. The result of these efforts is a system now capable of measuring, for the first time, the magnetic field profile across the diameter of a plasma test facility.

4.1 FR-5 Verdet TIP Probes and Sheet Retroreflector

The basis for measurements of magnetic fields in plasmas using the internal probe concept is to make use of the rotation of the polarization of radiation as it traverses a magneto-optic material. The rotation is proportional to the magnetic field, and is characterized by the Verdet coefficient (rotation/Gauss-cm). Initially in the program it was proposed to use Manganese-doped Cadmium Telluride as a probe material, due to its high Verdet coefficient of 0.17 °/G-cm. Use of this material proved difficult, however, due to the difficulty of fabricating optical quality samples, and to the high index of refraction. Samples tested had inclusions that scattered a significant fraction of the radiation, and the large index of refraction led to both high reflection losses and a high sensitivity of the amplitude of the return light to probe orientation.

During the current grant, we tested the use of terbium-doped borosilicate glass media (FR-5) [Hoya optics], and found this material much more suited to the TIP diagnostic, due to relative ease in fabricating optical quality samples, and the lower index of refraction and absorption than observed in the CdTe samples. Although the Verdet coefficient is only 0.00413 °/G-cm at the 628 nm He-Ne laser wavelength originally proposed to be used for the diagnostic, rectangular (4 mm x 4 mm) samples could easily be fabricated in longer lengths (10 mm) than the CdTe, which can provide a field resolution about 40 gauss at 632 nm. Moreover, the Verdet coefficient increases with decreasing wavelength, and the current use of an argon-ion laser at 514 nm, with higher powers than available with the He-Ne laser, allows a resolution below 30 gauss.

Recently a supplier was found for FR-5 type material having a higher Verdet coefficient (0.0095 °/G-cm at 514 nm) than that of the original samples, and a large number of 4 mm x 4 mm x 10 mm probes were obtained for extensive diagnostic tests and future applications of TIP. The probes were fabricated to precise dimensional tolerances, facilitating sabot construction and providing highly reproducible results in sabot separation. The polarization rotation for each probe was calibrated in a 2-Tesla superconducting magnet facility at the University.

The initial measurements of magnetic fields in the dropping experiments were carried out using corner cubes cemented to the rear faces to retroreflect the probe light back to the optical detection system. While these reflectors worked quite well, they are expensive to fabricate, and the convex shape requires special techniques for mounting in a sabot. For this reason, retroreflective sheet material, containing an array of microscopic corner-cubes was extensively tested during the grant period as a potentially more practical alternative to monolithic, single corner cubes. The sheet material proved to be very effective and easy to implement. The material was found to preserve the polarization of the probe light upon retroreflection, and to maintain its optical characteristics after the harsh acceleration by the light-gas gun. Square segments of the sheet are cut to the probe dimensions, and attached to the probes using UV cured optical adhesive.

The reflected light was found to dispersed over a full angle of about 5 °, resulting in a diminished detector signal in comparison with monolithic corner cubes. However, this is offset by the higher power available using the Argon-Ion laser, and sufficient light is collected to provide a high signal-to-noise ratio in our experiments.

4.2 Laser Illumination and Polarimeter

The basic laser illumination and polarimetry system was developed during previous TIP research efforts.[5, 11] For the research carried out under this grant the primary modifications were the use of a multiwatt Argon-Ion laser in place of the Helium Neon laser and the re-construction of the optical system for greater ease of alignment and higher light collection efficiency. The Ar laser's higher power made it easier to visualize the light path and provided a significantly larger signal at the detectors. The laser has a variety of wavelengths at which it can be operated, and the 514 nm line was chosen because of its high power and the high Verdet coefficient of FR-5 at this wavelength. Although in principle the Verdet coefficient is somewhat higher on the 457 nm laser line, absorption by FR-5 at this wavelength negates the advantage.

The initial polarimetry system that was used had the helium-neon laser mounted integrally with the polarimeter for compactness. The much larger Argon laser cannot be easily integrated with the polarimeter, and therefore the optical system was modified for use with this laser. The laser beam-splitter, collection lens, return-light beam splitters and detectors were mounted on a new, rigid table with improved mounts for adjusting the detector focal planes and lateral positions. Both the detector optics and laser beam-steering mirrors were redesigned to use low angles of incidence, and to maintain optical surfaces in the plane of polarization as far as possible, to minimize depolarization of the light. It had been found that the breakable mirrors that had been previously used to direct the laser along the probe flight path had variably curved surfaces, resulting in defocusing of the laser. These were replaced by more rigid mirrors of high optical quality. In addition it was found that the optical ports used for directing the beam into the vacuum had severe surface reflections due to the incident angle of the beams. Therefore, the system was modified to utilize a separate tube for admission of the probe beam, angled with respect to the TIP projectile axis to allow normal incidence into the attached optical port, to minimize reflections. The optical illumination system and polarimetry system currently used is illustrated in Fig. 4.1.

4.3 Magnetic Field Measurements

As a final test of the performance of the TIP diagnostic prior to applying it to measurements of magnetic fields in plasmas, the probe was fired at high speed (2.2 km/sec) through the vacuum interface into the measurement tank (simulating a plasma chamber) containing a static field generated by a horseshoe magnet. The probe was illuminated by Ar-ion laser light at 514 nm, directed down the probe flight axis by the

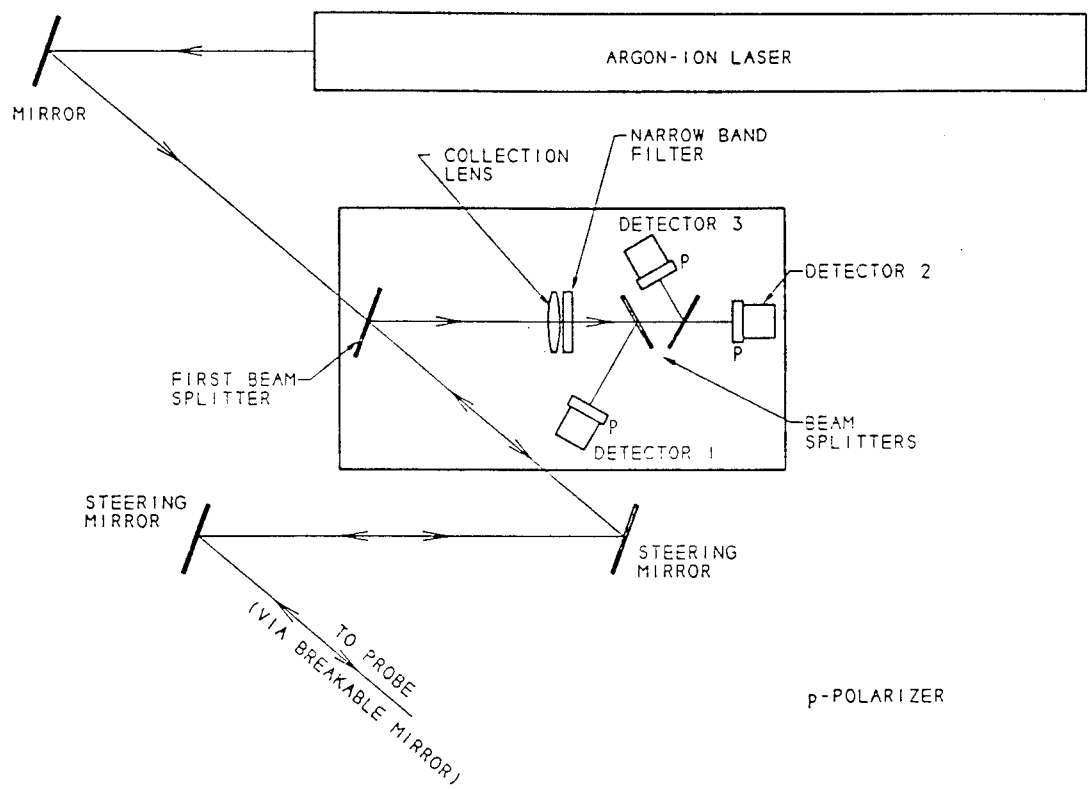

Fig. 4.1 Laser tracking optics and polarimeter.

breakable mirror in the probe catch tube, and the retroreflected light was collected by the polarimetry system. Signals from the polarimetry detectors were used to determine the axial component of the field vs. time as the probe traversed the field. The field's spatial profile could be extracted from the time history by measurement of the probe's position as a function of time. The latter was determined by the interruption of a He-Ne laser beam which crossed the probe's path at 2 points within the surge tank, separated by 0.73 m. Figure 4.2 shows a trace of the He-Ne signal, showing arrival times of the probe as negative-going pulses. Passage of the separated sabot is indicated by the broader pulse arriving shortly after the first probe pulse. These measurements provide a resolution of approximately 26 m/sec in probe velocity, corresponding to a maximum uncertainty of about 2 cm in probe position when it is near the emergent end of the plasma chamber.

Figure 4.3 shows the raw signal traces from the three polarimetry detectors, responding to polarization components of the retroreflected light 60 ° apart. The magnetic field can be determined by dividing each signal by the sum of the three signals as described in Refs. 5,11. The result is plotted by a solid line in Fig. 4.4. Also shown are the measurements of the magnetic field obtained by sliding a Hall probe along a track lying on the TIP probe axis (boxes). The agreement between the two measurements is excellent, and the derived statistical error in TIP measurements is ± 20 gauss. The spatial resolution of the TIP measurements is 1 cm.

These measurements constitute a full-up demonstration of the capability of the TIP diagnostic for measuring magnetic fields in a vacuum with a high-speed probe. They demonstrate the successful separation of probe from sabot and stripping of gun gases (since the pressure rise in the measurement tank was found to be in limits acceptable for a plasma device), the maintenance of probe attitude and retroreflector integrity during acceleration, the achievement of a high signal-to-noise ratio, and the high field resolution resulting from careful design of the optical train and polarimetry system. The TIP diagnostic is now ready for application to measurements of fields in plasmas, and will be used to measure the fields across the diameter of the UW HIT plasma in January of 1995.

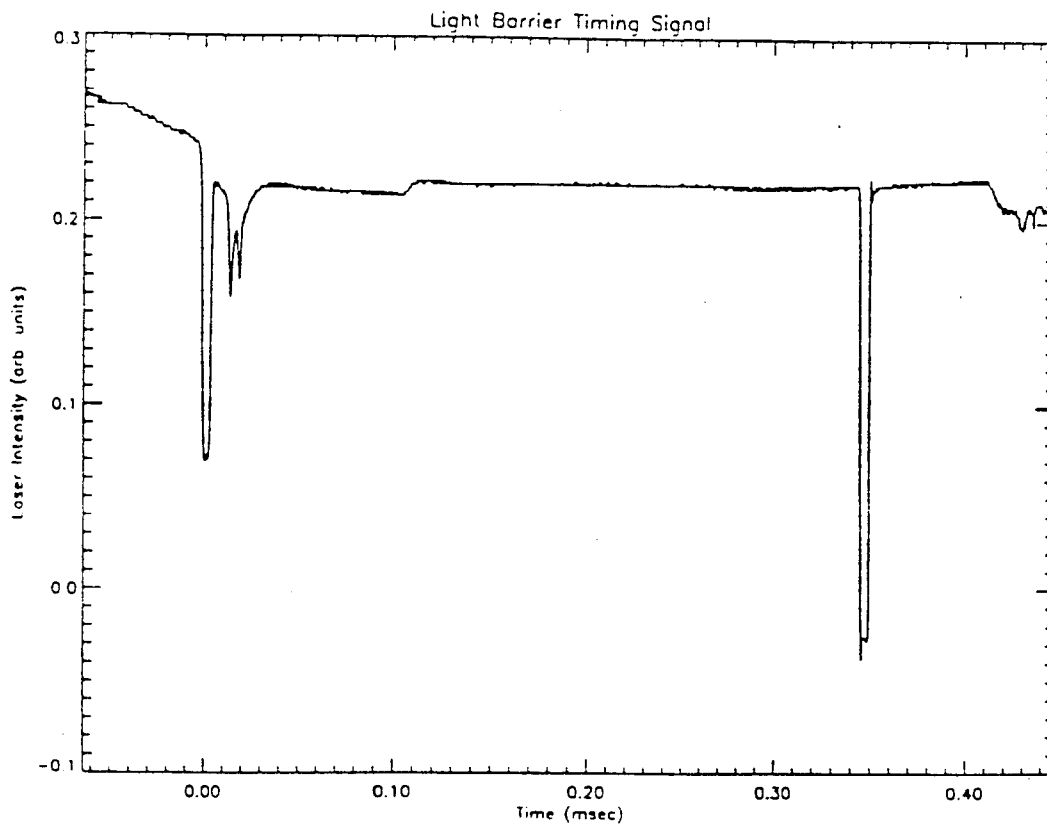

Fig. 4.2 He-Ne laser signal interrupted by passage of probe and sabot, used for velocity measurement. Separation of laser beams is 73 cm.

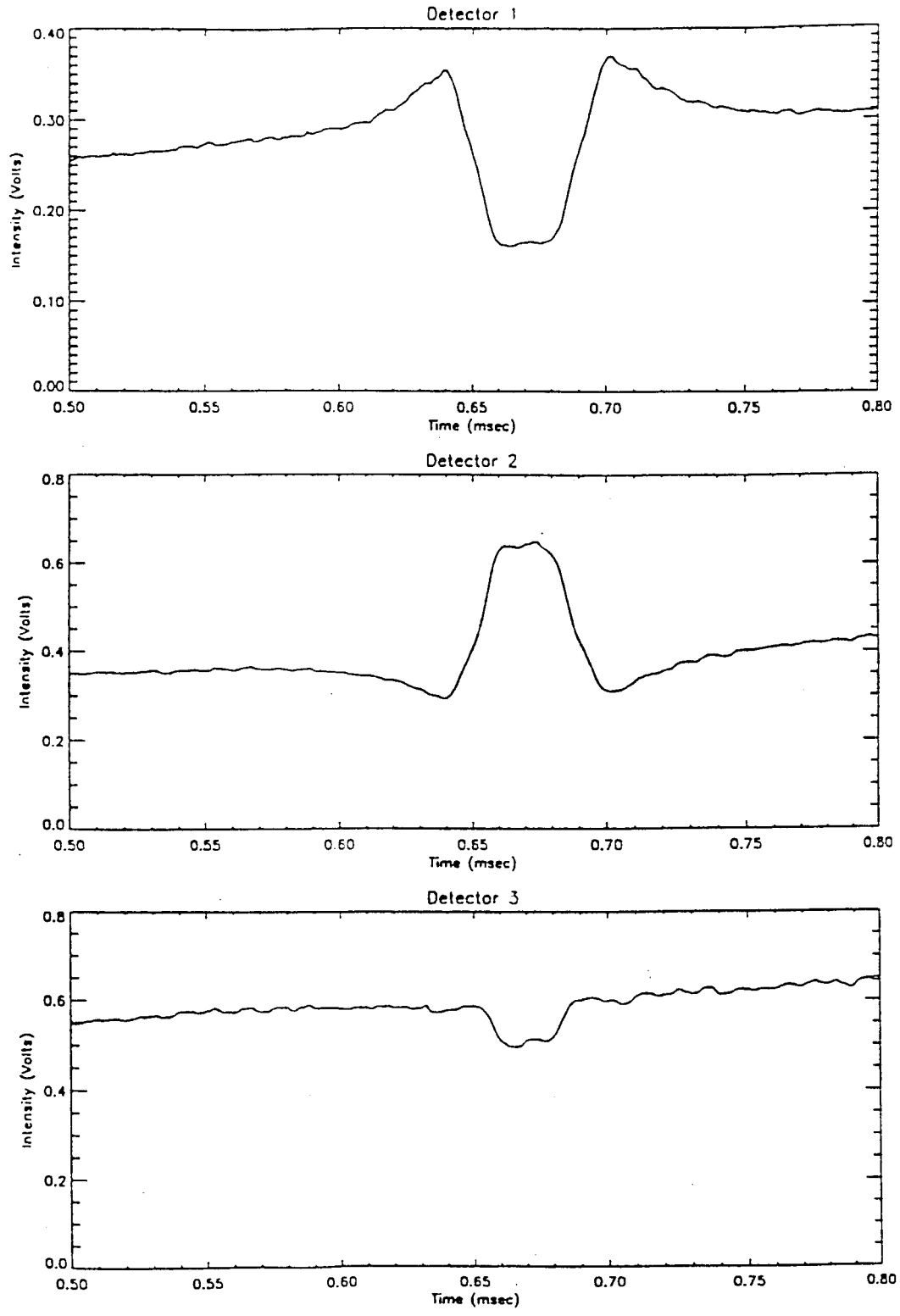

Fig. 4.3 Signals recorded by the 3 polarimeter detectors from light returning from probe moving at 2.2 km/sec through a static magnetic field.

Magnetic Field vs Position

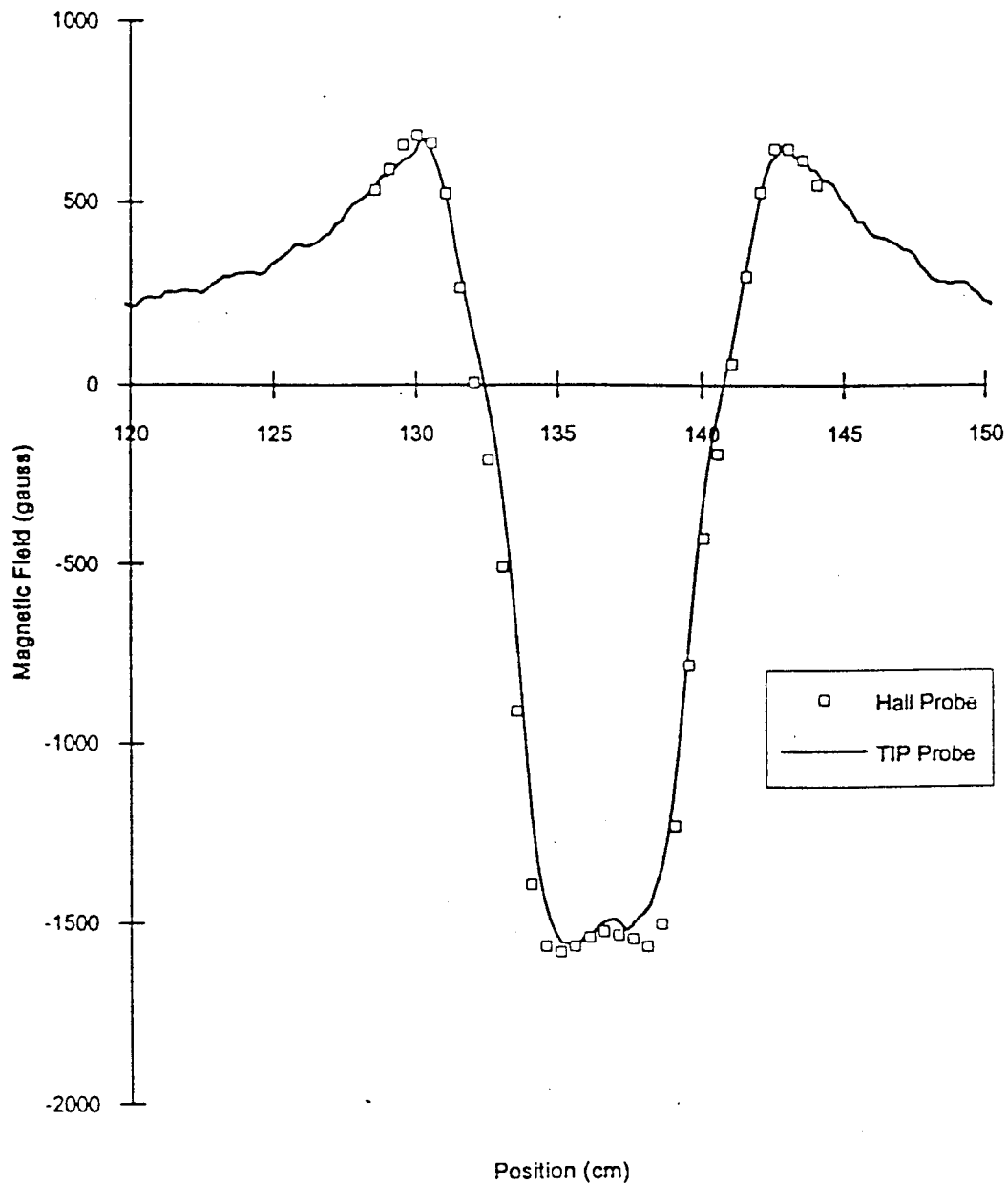

Fig. 4.4 Magnetic field profile derived from TIP probe at 2.2 km/sec (solid line), and static Hall probe measurements of the field (boxes). Spatial resolution is 1 cm.

5. REFERENCES

1. M. Lenoci and G. Haas, IPP (Garching), Report III/113 (July 1986).
2. G.G. Spanjers, et.al., "Development of a transient internal probe diagnostic," Rev. Sci. Instrum. 63, 5148 (1992).
3. G.G. Spanjers, et.al., "Development of a transient internal probe diagnostic," presented at 9th Topical Conference on High-Temperature Plasma Diagnostics, Santa Fe, N.M., March 15-19, 1992.
4. G.G. Spanjers, J.P. Galambos, M.A. Bohnet, and T.R. Jarboe, "Magnetic field measurements using the transient internal probe," presented at the APS Plasma Physics Conference, Seattle, WA, Nov. 16-20, 1992.
5. J.P. Galambos, "Remote magnetic field measurements using an optically coupled probe," M.S. Thesis, Univ. of Wash., Dept. of Nuclear Engineering, January, 1993.
6. M.A. Bohnet, "Development of a two-stage light gas gun," M.S. Thesis, Univ. of Wash., Dept. of Aeronautics and Astronautics, June, 1993.
7. J.P. Galambos, M.A. Bohnet, T.R. Jarboe, and A.T. Mattick, "Development of Transient Internal Probe (TIP) Magnetic Field Diagnostic," APS 35th Annual Plasma Physics Meeting, St. Louis, MO, Nov. 1-5, 1993.
8. M.A. Bohnet, J.P. Galambos, T.R. Jarboe, A.T. Mattick and G.G. Spanjers, "The transient internal probe: A novel method for measuring internal magnetic field profiles," APS 10th Topical Conference on High Temperature Plasma Diagnostics, Rochester, NY, May 8-12, 1994. [Accepted for publication in Rev. Sci. Inst.]
9. J.P. Galambos, M.A. Bohnet, T.R. Jarboe, and A.T. Mattick, "Development of Transient Internal Probe (TIP) Magnetic Field Diagnostic," 1994 IEEE International Conference on Plasma Science, Santa Fe, NM, June 6-8, 1994.
10. M.A. Bohnet, J.P. Galambos, T.R. Jarboe, and A.T. Mattick, "Magnetic field measurements at high velocity using a two-stage light-gas gun," 45th Aeroballistic Range Association Meeting, Huntsville, AL, Oct. 10-14, 1994.

11. T.R. Jarboe, "Transient Internal Probe," Final Report, AFOSR Grant 90-0345, December 15, 1993.
12. H.F. Swift and D.E. Strange, "Sabot discard technology," Physics Applications Inc., Internal Report, Oct. 1, 1987.
13. C.S. Engelbrecht, "A study of sabot deceleration behind an aerodynamic vehicle in a gas-filled tube," M.S. Thesis, University of Washington Department of Aeronautics and Astronautics, 1986.