

# REPORT DOCUMENTATION PAGE

Form Approved  
OAS No. 0704-0188

Public reporting burden for this collection of information is estimated to average 1 hour per response, including the time for reviewing instructions, searching existing data sources, gathering and maintaining the data needed, and completing and reviewing the collection of information. Send comments regarding this burden estimate or any other aspect of this collection of information, including suggestions for reducing this burden, to Washington Headquarters Services, Directorate for Information Operations and Reports, 1215 Jefferson Davis Highway, Suite 1204, Arlington, VA 22202-4302, and to the Office of Management and Budget, Paperwork Reduction Project (0704-0188), Washington, DC 20503

1. AGENCY USE ONLY (Leave blank)	2. REPORT DATE 1995, February	3. REPORT TYPE AND DATES COVERED Final Oct 92 - Apr 94	
4. TITLE AND SUBTITLE Combat Vehicle Command and Control System Evaluation: Vertical Integration of an Armor Battalion		5. FUNDING NUMBERS 63007A 795 2221 H01	
6. AUTHOR(S)  Lickteig, Carl W.; and Collins, III, Joel W.		8. PERFORMING ORGANIZATION REPORT NUMBER  ARI Technical Report 1021	
7. PERFORMING ORGANIZATION NAME(S) AND ADDRESS(ES) U.S. Army Research Institute for the Behavioral and Social Sciences ATTN: PERI-IK 5001 Eisenhower Avenue Alexandria, VA 22333-5600		10. SPONSORING / MONITORING AGENCY REPORT NUMBER  --	
9. SPONSORING / MONITORING AGENCY NAME(S) AND ADDRESS(ES)  --		11. SUPPLEMENTARY NOTES Joel W. Collins, III, is a graduate student at the University of Louisville and is a Consortium Fellow at the U.S. Army Research Institute Armored Forces Research Unit.	
12a. DISTRIBUTION / AVAILABILITY STATEMENT  Approved for public release; distribution is unlimited.		12b. DISTRIBUTION CODE  --	
13. ABSTRACT (Maximum 200 words) The U.S. Army is forging an integrated, digitally linked, force that will fight from a common real-time battle map to win the information war anticipated on the battlefield. Vertical integration that digitally links all echelons in a combat unit, such as a battalion, is required for full force integration. This Combat Vehicle Command and Control (CVCC) evaluation assessed the operational effectiveness of an armor battalion with digital connectivity between its platoon, company, and battalion echelons. Two hundred ten soldiers in duty assignments participated, including a fully manned, point platoon operating under company- and battalion-level commanders. The operational setting comprised a series of offensive maneuvers that required the point platoon's high-tempo response in a dynamic battlefield setting. The findings indicate that vertically linked digital Command and Control (C <sup>2</sup> ) systems provide significant advantages over voice-only communications on important battlefield functions under each of the tactical Battlefield Operating Systems tested: Maneuver, Fire Support, Command and Control, and Intelligence. The method used in this evaluation provided an example of how simulation-based technologies can meet future C <sup>2</sup> training and evaluation requirements.			
14. SUBJECT TERMS Command, control, and communication (C <sup>3</sup> ) Human performance Simulation-based training		Digital C <sup>2</sup>	15. NUMBER OF PAGES 149
17. SECURITY CLASSIFICATION OF REPORT Unclassified		18. SECURITY CLASSIFICATION OF THIS PAGE Unclassified	16. PRICE CODE --
17. SECURITY CLASSIFICATION OF REPORT Unclassified		19. SECURITY CLASSIFICATION OF ABSTRACT Unclassified	20. LIMITATION OF ABSTRACT Unlimited

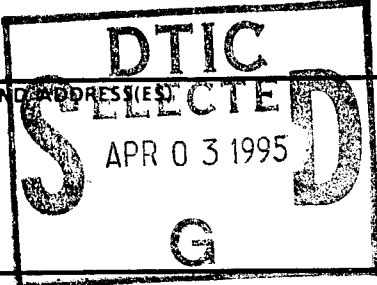

Technical Report 1021

# **Combat Vehicle Command and Control System Evaluation: Vertical Integration of an Armor Battalion**

**Carl W. Lickteig and Joel W. Collins, III**  
U.S. Army Research Institute

**February 1995**



**United States Army Research Institute  
for the Behavioral and Social Sciences**

**DTIC QUALITY INSPECTED 1**

Approved for public release; distribution is unlimited.

**19950328 117**

# U.S. ARMY RESEARCH INSTITUTE FOR THE BEHAVIORAL AND SOCIAL SCIENCES

A Field Operating Agency Under the Jurisdiction  
of the Deputy Chief of Staff for Personnel

**EDGAR M. JOHNSON**  
Director

Technical review by

Dorothy L. Finley  
Margaret S. Salter

Accession For	
NTIS CRA&I	<input checked="" type="checkbox"/>
DTIC TAB	<input type="checkbox"/>
Unannounced	<input type="checkbox"/>
Justification .....	
By .....	
Distribution /	
Availability Codes	
Dist	Avail and/or Special
A-1	

## NOTICES

**DISTRIBUTION:** Primary distribution of this report has been made by ARI. Please address correspondence concerning distribution of reports to: U.S. Army Research Institute for the Behavioral and Social Sciences, ATTN: PERI-POX, 5001 Eisenhower Ave., Alexandria, Virginia 22333-5600.

**FINAL DISPOSITION:** This report may be destroyed when it is no longer needed. Please do not return it to the U.S. Army Research Institute for the Behavioral and Social Sciences.

**NOTE:** The findings in this report are not to be construed as an official Department of the Army position, unless so designated by other authorized documents.

Technical Report 1021

**Combat Vehicle Command and Control System  
Evaluation: Vertical Integration  
of an Armor Battalion**

**Carl W. Lickteig and Joel W. Collins, III**  
U.S. Army Research Institute

**Armored Forces Research Unit at Fort Knox, Kentucky**  
**Barbara A. Black, Chief**

**Training Systems Research Division**  
**Jack H. Hiller, Director**

U.S. Army Research Institute for the Behavioral and Social Sciences  
5001 Eisenhower Avenue, Alexandria, Virginia 22333-5600

Office, Deputy Chief of Staff for Personnel  
Department of the Army

**February 1995**

---

**Army Project Number**  
**20263007A795**

**Training Simulation**

Approved for public release; distribution is unlimited.

## FOREWORD

---

As part of the U.S. Army Research Institute for the Behavioral and Social Sciences (ARI) program to train the force, the objective of the Future Battlefield Conditions team at Fort Knox is to enhance soldier preparedness through identification of future battlefield conditions and the development of training methods to meet those conditions. ARI's research on training requirements and methods for future automated Command and Control (C<sup>2</sup>) systems is supported by Memorandums of Agreement between ARI-Knox and the Tank Automotive Command (TACOM) on Combat Vehicle Command and Control (CVCC), 22 March 1989, and between ARI-Knox and the U.S. Army Armor Center (USAARMC) and Fort Knox on Research in Future Battlefield Conditions, 12 April 1989.

The U.S. Army is forging an integrated, digitally linked, force that will fight from a common real-time battle map to win the information war anticipated on the future battlefield. Full force integration will require horizontal linkages across functional areas such as armor, infantry, and artillery, as well as vertical linkages between echelons within a combat unit, such as an armor battalion. In support of this effort, ARI conducted a series of simulation-based CVCC evaluations on future C<sup>2</sup> systems to assess their operational effectiveness, soldier-machine interface (SMI), and training requirements.

This report assesses the operational effectiveness of an armor battalion equipped with future digital C<sup>2</sup> systems that vertically linked the unit's platoon, company, and battalion echelons. The findings indicate that vertically linked digital C<sup>2</sup> systems provide significant advantages over voice-only communications on important battlefield functions under each of the tactical Battlefield Operating Systems tested: Maneuver, Fire Support, Command and Control, and Intelligence. The method used in this evaluation provides an example of how simulation-based technologies can meet C<sup>2</sup> training and evaluation requirements.

Findings and information resulting from the CVCC research program have been briefed to the following personnel: Commanding General, U.S. Army Training and Doctrine Command; Commanding General, U.S. Army Armor Center and School; Deputy Commanding General for Combat Developments, U.S. Army Combined Arms Command; Deputy Chief of staff for Training, U.S. Army Training and Doctrine Command; Chief of Staff, U.S. Army Armor School; Director, Directorate of Combat Developments, U.S. Army Armor School; and Director, Mounted Warfighting Battlespace Laboratory.

EDGAR M. JOHNSON  
Director

# COMBAT VEHICLE COMMAND AND CONTROL SYSTEM EVALUATION: VERTICAL INTEGRATION OF AN ARMOR BATTALION

## EXECUTIVE SUMMARY

---

### Requirement:

The U.S. Army is forging an integrated, digitally linked, force that will fight from a common real-time battle map to win the information war anticipated on the battlefield. Full force integration will require digital Command and Control (C<sup>2</sup>) systems that link units horizontally and echelons vertically. This report assesses the operational effectiveness of an armor battalion equipped with digital C<sup>2</sup> systems, Combat Vehicle Command and Control (CVCC) systems, that vertically link the unit's platoon, company, and battalion echelons.

### Procedure:

The evaluation's between-subjects design compared the performance of CVCC-equipped units with conventionally equipped, voice-based, units. Participants included 210 soldiers in duty assignments that included a fully manned, point platoon operating under company- and battalion-level commanders. Performance data were obtained in the simulation-based Mounted Warfare Test Bed during a series of exercises based on Fragmentary Orders (FRAGOs) that forced the point platoon's high-tempo response in a dynamic battlefield setting.

### Findings:

The findings indicated that vertically linked digital C<sup>2</sup> systems provided significant advantages over voice-only communications for many of the critical battlefield functions tested under four Battlefield Operating Systems: Maneuver, Fire Support, Command and Control, and Intelligence. In summary, CVCC units excelled in executing the FRAGO's demanding maneuver and mission requirements, in acquiring and killing the threat at extended range, and in maintaining the high-tempo pace required by current doctrine and the future battlefield. CVCC commanders excelled in transmitting and receiving information on mission, threat, and friendly troops that is critical to their visualization of battlespace.

## Utilization of Findings:

The findings support the Army's requirement to forge a digitally integrated force and vertically link the echelons within a unit to increase operational effectiveness and C<sup>2</sup> potential. The findings provide soldier-in-the-loop data to Army developers of doctrine, materiel, and training for digital C<sup>2</sup> systems. The method used provides an example of how simulation-based technologies can meet C<sup>2</sup> training and evaluation requirements.

COMBAT VEHICLE COMMAND AND CONTROL SYSTEM EVALUATION:  
VERTICAL INTEGRATION OF AN ARMOR BATTALION

CONTENTS

---

	Page
INTRODUCTION . . . . .	1
Military Requirement . . . . .	2
General Research Requirement: CVCC Research Program . . . . .	4
Current Research Requirement: Vertical Integration of an Armor Battalion . . . . .	14
OBJECTIVES, ISSUES, AND HYPOTHESES . . . . .	15
METHOD . . . . .	15
Participants . . . . .	15
Apparatus . . . . .	18
Training and Test Materials . . . . .	21
Performance Measures . . . . .	23
Procedure . . . . .	24
Design . . . . .	32
Data Reduction and Analysis . . . . .	33
RESULTS AND DISCUSSION . . . . .	34
Group Equivalence . . . . .	34
Maneuver BOS . . . . .	34
Fire Support BOS . . . . .	52
Command and Control BOS . . . . .	54
Intelligence BOS . . . . .	70
CONCLUSIONS . . . . .	74
REFERENCES . . . . .	79
APPENDIX A. EVENT LISTS FOR TRAINING AND TEST EVENTS . . . . .	A-1
B. OPERATIONS ORDER'S (OPORD'S) SCRIPTED PRESENTATION . . . . .	B-1

CONTENTS (Continued)

	Page
APPENDIX C. FRAGMENTARY ORDER CONTENTS AND SCORING GUIDELINES . . . . .	C-1
D. INTELLIGENCE REPORT CONTENTS AND SCORING GUIDELINES . . . . .	D-1
E. BATTLE MASTER AND PVD LOGS . . . . .	E-1
F. BIOGRAPHICAL QUESTIONNAIRE . . . . .	F-1
G. SUMMARY OF BIOGRAPHICAL DATA . . . . .	G-1
H. SOURCE TABLES FROM MANOVA ANALYSES, BY MEASURE . . . . .	H-1
I. DEBRIEF COMMENTS . . . . .	I-1
J. LIST OF ACRONYMS AND ABBREVIATIONS . . . . .	J-1

LIST OF TABLES

Table	1. The Mounted Warfare Test Bed's Major Features . . . . .	10
	2. Comparison of Baseline and CVCC M1 Simulator Functions . . . . .	20
	3. Overview of Training and Test Exercises . . . . .	22
	4. Typical Scenario Sequence for Training and Test Exercises . . . . .	23
	5. Objectives for the Training Exercise . . . . .	24
	6. Performance Measures by Battlefield Operating System (BOS) and Combat Functions . . . . .	28
	7. Mean Performance for Move on the Surface Measures, by Condition . . . . .	35

CONTENTS (Continued)

		Page
Table	8. Mean Performance for Selected Navigate Measures, by Echelon and Condition . . . . .	40
	9. Mean Performance for Selected Process Direct Fire Targets Measures, by Echelon and Condition . . . . .	44
	10. Mean Performance for Selected Engage Direct Fire Targets Measures, by Condition . . . . .	48
	11. Mean Performance for Selected Engage Direct Fire Targets Measures, by Echelon and Condition . . . . .	49
	12. Mean Performance for Process Ground Targets Measures, by Echelon and Condition . . . . .	53
	13. Mean Performance for Receive and Transmit the Mission Measures, by Echelon and Condition . . . . .	55
	14. Mean Performance for Selected Receive and Transmit Enemy Information Measures, by Echelon and Condition . . . . .	59
	15. Mean Performance for Selected Receive and Transmit Friendly Troop Information Measures, by Condition . . . . .	63
	16. Mean Performance for Manage Means of Communicating Information Measures, by Echelon and Condition . . . . .	66
	17. Mean Performance for Selected Collect Threat Information Measures, by Echelon and Condition . . . . .	71
	18. Significantly Improved CVCC Performance, by Battlefield Operating System . . . . .	75

LIST OF FIGURES

Figure	1. Commander's CVCC workstation with CITV at center and CCD at right . . . . .	7
	2. Command and Control Display in operational mode . . . . .	7

## CONTENTS (Continued)

---

	Page
Figure 3. Training and evaluation schedule . . . . .	12
4. Vertical slice battalion manning structure . . . . .	17
5. B Company wedge formation, 1st Platoon on point, based on Standard Operating Procedure (SOP) . . . . .	17
6. Operational overlay for operation order, Movement to Contract . . . . .	25
7. Operational overlay for fragmentary order, Assault from Movement to Contract . . . . .	26
8. Measures for receive and transmit mission based on tactical command and control battlefield operating system . . . . .	27
9. Mean exposure to opposing force (OPFOR), by exercise and condition . . . . .	36
10. Mean number of platoon vehicles within 100 meters of each other and beyond 200 meters, by condition . . . . .	37
11. Mean distance from scripted end point of each exercise, by condition . . . . .	38
12. Mean percent of time that manned company and platoon vehicles were not moving (vs. moving) and moving faster than 40 km/hr (vs. slower), by condition . . . . .	41
13. Mean minimum time between lases to different targets, by condition . . . . .	45
14. Mean maximum lase range to enemy targets, by condition . . . . .	45
15. Mean target hit range per manned simulator, by echelon and condition . . . . .	50

CONTENTS (Continued)

		Page
Figure	16. Mean number of main gun rounds fired per manned simulator, by echelon and condition . . . . .	51
	17. Mean number of Calls For Fire (CFF) per exercise with required grid location, by condition . . . . .	54
	18. Mean percent of Calls For Fire (CFF) with correct enemy type, by condition . . . . .	54
	19. Mean cumulative time to transmit Fragmentary Order (FRAGO), by echelon and condition . . . . .	56
	20. Mean time to relay reports between echelons, by report type and condition . . . . .	60
	21. Mean number of voice communications between battalion echelon and TOC, excluding named and scripted reports, by condition . . . . .	64
	22. Mean duration of voice communications between battalion echelon and TOC, excluding named reports, by condition . . . . .	64
	23. Mean duration of voice transmissions per exercise, by radio net and condition . . . . .	67
	24. Mean number of voice transmissions per exercise, by radio net and condition . . . . .	68
	25. Mean total time of voice transmissions per exercise, by radio net and condition . . . . .	69
	26. Mean number of named voice reports per exercise, by radio net and condition . . . . .	70
	27. Mean accuracy of collect threat information reports based on reported locations, by report type and condition . . . . .	72

CONTENTS (Continued)

---

	Page
Figure 28. Mean number of scorable collect threat information reports per exercise based on location data, by report type and condition . . . . .	73

# COMBAT VEHICLE COMMAND AND CONTROL SYSTEM EVALUATION: VERTICAL INTEGRATION OF AN ARMOR BATTALION

## INTRODUCTION

Information is power, and a precept of the ongoing revolution in land warfare is that "combat power follows information" (Franks, 1994). The U.S. Army is forging an integrated, digitally linked, force that will fight from a common real-time battle map to win the information war anticipated on the future battlefield. Future Command and Control (C<sup>2</sup>) systems must share information across combat and supporting units to ensure horizontal and vertical integration of this force (Sullivan, 1994; U.S. Department of the Army, 1993b).

In support of this Army effort and Armor's lead in the fielding of vehicle based automated C<sup>2</sup> systems, the Army Research Institute (ARI) at Fort Knox participated in the Combat Vehicle Command and Control (CVCC) Research and Development (R&D) program. In this research, ARI conducted a series of simulation-based evaluations on future C<sup>2</sup> system configurations, called CVCC, to assess their operational effectiveness, soldier-machine interface (SMI) and training requirements. These evaluations compared the performance of CVCC-equipped units using automated C<sup>2</sup> systems with conventional, baseline, units using voice radio, grease pencils and acetate overlay sheets. This CVCC effort culminated with separate battalion-level evaluations on the effects of horizontal and vertical integration of digital C<sup>2</sup> systems in a multiechelon armor force.

Horizontal integration of digital C<sup>2</sup> systems in an armor battalion was evaluated by assigning participants to company and battalion command groups that engaged in a full-mission scenario. Results from this prior simulation-based evaluation demonstrated that a CVCC-equipped battalion was significantly more effective in conducting defensive and offensive combat operations, as tested (Leibrecht, Meade, Schmidt, Doherty, & Lickteig, 1994). Key areas of improved performance included faster and more accurate communication of reports and overlays, more synchronized movement and faster mission execution, and greater range and speed in target acquisition. Results also identified training requirements, SMI issues, and potential tactics, techniques and procedures associated with future automated C<sup>2</sup> systems (Atwood, Winsch, Sawyer, Ford, & Quinkert, 1994; Meade, Lozicki, Leibrecht, Smith, & Myers, 1994).

Vertical integration that digitally links all echelons within a combat unit, such as an armor battalion, is also required to forge a digitally integrated force. This report addresses the operational effectiveness of an armor battalion with digital connectivity between its platoon, company and battalion echelons. Participant assignments included a fully manned point platoon that operated under company and battalion level commanders. The operational setting comprised a series of offensive maneuvers that required the point platoon's high-tempo response in a dynamic battlefield setting. Results from this vertical evaluation are reported herein and organized by the following tactical Battlefield Operating Systems (U.S. Army Training and Doctrine Command, 1991): Maneuver, Fire Support, Command and Control, and Intelligence.

## Military Requirement

The Army's vigorous battlefield digitization effort evidences the high-driver requirement for horizontal and vertical integration of digital C<sup>2</sup> systems across echelons and functional areas (Clark, 1993; Foley, 1992; Ross, 1994; Sullivan, 1994; U.S. Department of the Army, 1993b). Desert Storm's precision-warfare success vividly demonstrated to the world the unparalleled impact of advanced technologies such as C<sup>2</sup> on force lethality, survivability and tempo. This success "...proved for the first time that modern wars will be won through the effective use of command, control, communications and intelligence (C<sup>4</sup>I) technology" (Ross, 1994, p. 27).

Despite the success of Desert Storm, the advanced C<sup>2</sup> assets of the combat vehicle force remain limited and poorly integrated, particularly with respect to the vertical linkage of all echelons within a combat unit such as an armor battalion. During Desert Storm, critical information was frequently not available to the vehicle commanders who needed it, or it was submerged in a flood of less relevant information (Burkett, 1991; Giboney, 1991). With respect to Armor, for example, very few main battle tanks with automated C<sup>2</sup> systems, M1A2s, have been developed for the U.S. Army. And the Army's effort to equip the force with automated C<sup>2</sup> systems underscores the fact that its conventional mode for communication is predominantly voice-based radio.

While voice radio provides pronounced advantages over the bugle calls and carrier pigeons employed in earlier military campaigns, critical limitations in voice-based C<sup>2</sup> systems are magnified on the modern battlefield (U.S. Department of the Army, 1993a). In particular, voice-based limitations impact information reception and processing. For example, company level voice data from the National Training Center (NTC) revealed that net overload resulted in almost 30-second waits to access a net, that call signs and authentication procedures accounted for over one-half of the "information" transmitted, and nearly one-third of all messages were lost due to interference (Phelps and Kupets, 1984). Compounding the reception problem, information received over voice-radio is often dangerously inaccurate (Du Bois & Smith, 1991; Funk, 1994; Leibrecht et al., 1992).

Information processing, due to voice-based limitations, is even more problematic. Tactical military communications usually convey spatial-geographic data such as the locations of enemy and friendly units or the locations of graphic control measures that illustrate the concept for combat operations. Voice communicators must repeatedly encode spatial data into alphanumeric formats or "grids" (e.g., ES 2345 6789) and receivers must decode it back to analog formats, map plots. The communication of more complex, map-based data such as operational overlays routinely forces armored units to dismount and hand copy these essential graphics in a nonarmored setting!

The Army realizes its emerging doctrine dictating high-tempo operations is severely compromised by the limitations of voice-based communication systems (U.S. Department of the Army, 1993a). A notable example, the concept of battlespace--the use of the entire battlefield to apply combat power to affect the enemy--encompasses the

physical dimensions of the battlefield as well as the accelerated operational dimensions of time, tempo, depth and synchronization (U.S. Department of the Army, 1993b). Similarly, the fundamental prerequisite of the evolving concept of battle command is the ability to visualize this battlespace. Every commander's decision-making and leadership skills are dependent upon this ability (U.S. Department of the Army, 1993a).

Visualization of battlespace is a continuous process based on myriad bits of information, still predominantly received from voice-based communications. This visualization requires an awareness of the current and future status of friendly and enemy forces and the formulation of operational concepts to accomplish the mission (U.S. Department of the Army, 1993a). Timely and accurate visualization must be maintained by a commander whether his location is a command post, a Tactical Operations Center (TOC), a main battle tank or dismounted for a reconnaissance, a mission brief or mission rehearsal. A commander's access to the information required for visualization is dependent upon the resources available at these locations.

Even if voice-based C<sup>2</sup> systems are available, visualization is restricted by these systems' limitations for receiving information. Even if timely and accurate information is received, information processing requirements such as repeated digital-to-analog conversions severely impair a commander's visualization. The greatest disparity between C<sup>2</sup> system capabilities versus doctrinal and operational requirements is experienced by a maneuver unit commander (U.S. Department of the Army, 1993a). Maneuver unit commanders operate "on the move" at the forward edge of the battle where they must continuously synchronize the positional advantage of the combined arms force (DePuy, 1988).

Concepts such as battlespace visualization and force synchronization may seem the domain of only higher echelon commanders, but that is not the case. The same C<sup>2</sup> functions are executed by every Army leader using the C<sup>2</sup> systems available. Regardless of the communication system, the C<sup>2</sup> process entails acquiring information, assessing its impact, determining a course of action and directing its execution (U.S. Army Training and Doctrine Command, 1991). The "unity of effort" implicit in combined arms operations requires that all commanders share a common understanding of their battlespace and that each commander ensures his unit's efforts are in synch with that of the total force.

The requirement for integrating digital C<sup>2</sup> systems is only one component of force integration. Force integration is a complex construct that melds all organizational assets to unified function. It provides the basis for the force synchronization function which is "the ability to focus resources and activities in time and space to produce maximum relative combat power at the decisive point" (U.S. Department of the Army, 1993a, p. Glossary-8). Enabling components of force integration in the soldier domain, for example, include individual and collective training on combat fundamentals and operations as directed by uniform tactics, techniques and procedures. Similarly, in the materiel domain, the integration of digital C<sup>2</sup> systems across horizontal and vertical organizational structures is regarded as an enabling component of force integration.

Fielding of automated C<sup>2</sup> systems for the future battlefield, therefore, means the provision of digital "connectivity" across the force. Full connectivity must establish horizontal linkages across echelons and battlefield functional areas such as armor, aviation, artillery and infantry. Horizontal integration of digital C<sup>2</sup> systems is a particularly challenging and crucial goal in the Army's modernization strategy. Vertical integration of future C<sup>2</sup> systems is also an essential requirement for a digitally integrated force. Armor's operational concept for an automated C<sup>2</sup> system in the Abrams main battle tank strongly reinforces this requirement (U.S. Army Armor Center, 1992). Vertical integration between echelons is dutifully described for commanders at each battalion echelon during the planning, preparation and execution phases of an operation. In addition, this concept paper cogently argues the potential synergy of vertical integration as a force multiplier.

Similarly, Clark's (1993) futuristic vignette titled "Digitization: Key to Landpower Dominance" dramatically illustrates the anticipated effects of vertical integration: omniscient visualization of friendly and enemy locations; choreographed maneuver around enemy locations, obstacles and engagement areas; extemporaneous massing and dispersion of forces; and automated fire distribution and target designation resulting in instantaneous lethality. Clark postulated that landpower dominance is ultimately achieved through vertical integration of digital C<sup>2</sup> systems. "These efforts will move us toward ensuring battlespace synchronization, point-of-engagement identification, near real-time command battlespace picture and situational awareness at the lowest levels" (Clark, 1993 p. 30).

In summary, the purpose of any command and control system is to provide accurate and timely information for commanders to develop feasible courses of action, make logical decisions and control their execution (U.S. Department of Army, 1985). The military requirement for a digitally integrated force does not change that purpose, rather it reflects the need for more timely and accurate information to empower combat forces on the future battlefield.

#### General Research Requirement: CVCC Research Program

Research and development efforts are sorely needed to meet the military requirement for fielding a digitally integrated force on the future battlefield. Fielding challenges to digital integration include: compatible, ruggedized hardware and software across the battlefield functional areas; a robust and integrated C<sup>2</sup> system architecture that ensures connectivity, digital force integration; and extensive user-based assessments of integrated systems in demanding, realistic combined arms operations.

Training challenges to digital force integration are also formidable. Digital systems are not "business as usual" (U.S. Army Armor Center, 1994). If digitization is the key to landpower dominance, the seemingly surreal capabilities envisioned (Clark, 1993) will exact warriors trained to exploit the inherent power of information (U.S. Department of the Army, 1994). An overriding concern is to ensure that the deluge of information provided by such systems does not mask essential elements of combat

information (Burkett, 1991; Giboney, 1991). On the other hand, the computer-based nature of digital C<sup>2</sup> systems provides an excellent medium for embedded training packages. Similarly, simulation-based training in an integrated, combined arms environment should enable future soldiers to hone digitally-based C<sup>2</sup> skills such as information management, battlespace visualization and battle command.

Background for the current evaluation of a vertically integrated armor battalion dates to Armor's proactive lead in the mid 1980's to harness the power of digitization on main battle tanks. With the assistance of the Armor School's Directorate of Combat Developments (DCD), preliminary concepts for automated C<sup>2</sup> systems were identified (Blasche and Lickteig, 1984) to develop a stand-alone, computer-based model for assessing user-interface requirements. Guided by these requirements, a system description (U.S. Army Armor Center, 1988) and specification (Lickteig, 1988) directed the development of an interactive C<sup>2</sup> system for soldier-in-the-loop assessment in a simulation-based operational setting. The research setting selected was SIMulation NETworking Developmental (SIMNET-D), later referred to as the Close Combat Test Bed, and currently the Mounted Warfare Test Bed (MWTB).

Working from this initial design, ARI-Knox initiated in 1988 a series of automated C<sup>2</sup> system evaluations in the MWTB that ranged from tank to battalion. Based on a bottom-up design philosophy, assessments of automated C<sup>2</sup> capabilities at lower echelons were to be followed by assessments on the horizontal and vertical integration of these echelons. This bottom-up approach began with crew and platoon evaluations that demonstrated significant improvements in performance with automated C<sup>2</sup> systems. Enhanced performance included significantly faster and more accurate reporting, navigation, maneuver and target processing (Du Bois & Smith, 1989, 1991). These evaluations also identified user-based modifications for C<sup>2</sup> design and training in future research and development efforts.

Spurred by the demonstrated potential of C<sup>2</sup> research in the MWTB, the U.S. Army Tank-Automotive Command, the Army's tank builder, requested that ARI-Knox join the CVCC program. CVCC's R&D program (1988-1993) was a bilateral, United States-German, effort to address interoperable C<sup>2</sup> requirements in ground combat vehicles. CVCC program goals included the development and integration, within and between tanks, of advanced digital technologies to support tank-based generation, reception and processing of combat-critical information. ARI's primary objective was to extend its earlier crew and platoon efforts on digital C<sup>2</sup> systems to company and battalion levels (Leibrecht et al., 1994). Key research issues for ARI, as head of CVCC's Simulation & Soldier-Machine Interface Team, were operational effectiveness, SMI and training requirements.

The remainder of this section describes ARI's programmatic efforts to meet these research requirements. This review documents the general method developed and used for CVCC's program of research. Research requirements to conduct CVCC company and battalion efforts included: developing a simulation-based suite of integrated CVCC components designed to enhance the move, shoot and communicate performance of

armor units; developing a system architecture for digital connectivity compatible with the MWTB's distributed network; and developing the training, support and measurement packages required for these evaluations.

CVCC System Development. Three advanced tank components were developed and integrated in simulation to form the CVCC system used in ARI's research efforts in the MWTB. The Command and Control Display (CCD) was developed for tank-based digital communications, the primary objective of CVCC. Navigation and target acquisition components, integrated with the CCD, were an on-board Position Navigation (POSNAV) system and the Commander's Independent Thermal Viewer (CITV). The commander's interface to these CVCC components is illustrated in Figure 1, the commander's CVCC equipped workstation.

Development of the CCD began with SMI refinements requested by the soldier participants during ARI's earlier crew and platoon evaluations of digital C<sup>2</sup> systems (Du Bois & Smith, 1989, 1991). This redesign included a modular and modifiable architecture that allowed commanders to tailor the CCD interface to their immediate operational requirements, and researchers to continue iterative, post-evaluation modifications based upon participant recommendations (Greess, 1994). For a detailed description of the CCD design used in the current evaluation on vertical integration, see LaVine, Lickteig and Schmidt (1993) and Leibrecht et al. (1993).

Commanders' visualization of the battlefield was a paramount concern in the design of the CCD. To maintain an accurate portrayal of the current battlefield situation, the CCD automatically converts battlefield communications such as reports and overlays into analog formats and accurately plots these graphics onto the CCD's tactical map. As depicted in Figure 2, this tactical map is generated from a resident, digital-terrain data base and updated by communications such as an operational overlay, icons of own, friendly and enemy vehicles, and a Spot report prepared for transmission. An incoming Intelligence report, for example, might contain friendly, enemy and obstacle information. As this report is received, the CCD automatically displays blue, red and green icons on the tactical map for each of these reported elements, respectively. These color-coded icons are portrayed as standard military symbols and automatically positioned at their reported locations.

Similarly, own and friendly vehicle icons are routinely repositioned on the tactical map as the CCD receives location updates from friendly vehicles on the move. The POSNAV component provides own-vehicle location and heading data in analog and digital format on the commander's CCD. Digital exchange of this location data to other commanders' CCDs results in continuous, graphical updates on the friendly situation. Within each tank, own location and heading data are used to generate navigation and maneuver routes on the tactical map and route "waypoints" on a driver's display that continuously updates the steering direction required to reach the next waypoint. The ability, such as CVCC's, to communicate routes, friendly locations and overlays across a digitally integrated force is the basis for expectations of synchronized navigation, maneuver, mass and dispersion (Clark, 1993).

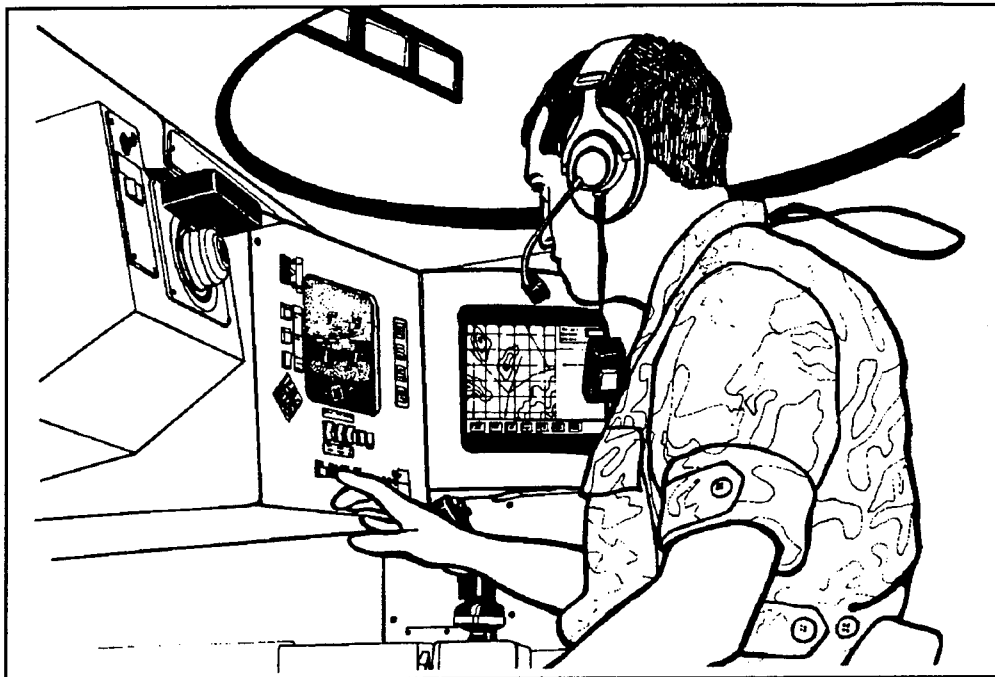

Figure 1. Commander's CVCC workstation with CITV at center and CCD at right.

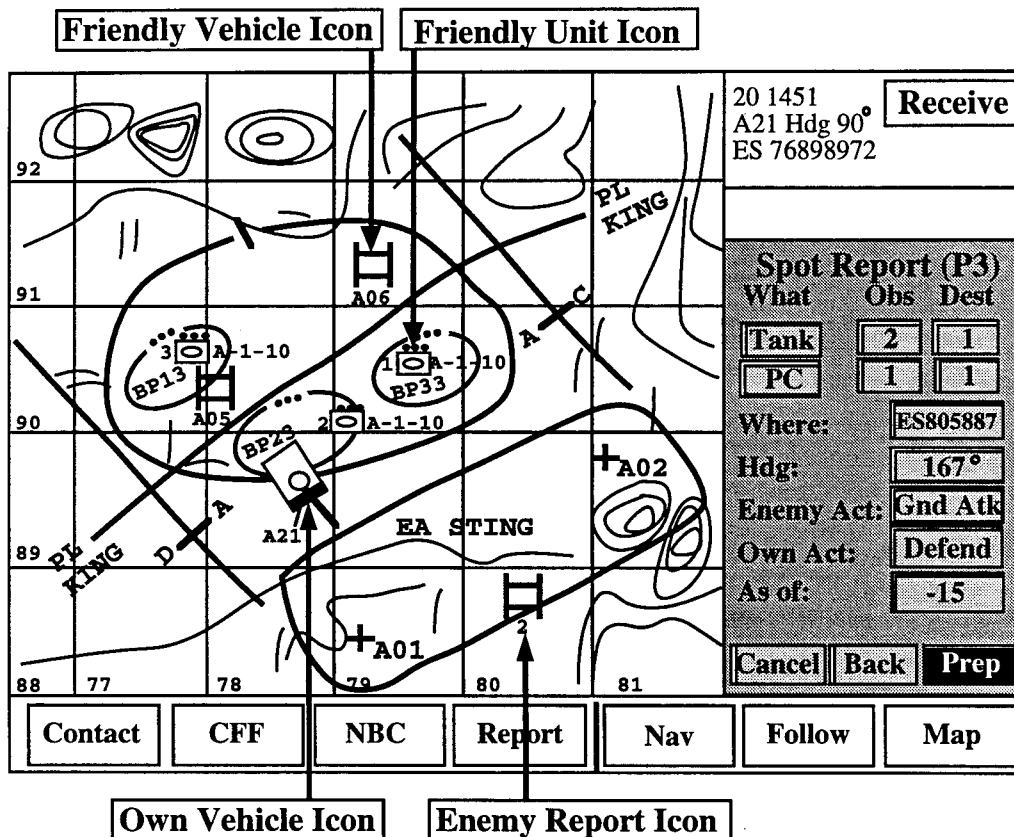

Figure 2. Command and Control Display in operational mode.

The CITV provides the commander an independent thermal view of the battlefield that supports simultaneous hunter-killer activities by the commander and gunner, respectively (Quinkert, 1990). CITV's integration with the CCD and fire-control components enables far-target designation: target lases from the commander's CITV or the gunner that automatically input accurate grid locations into CCD-based reports on enemy location and activity. The ability, such as CVCC's, to communicate this enemy location data rapidly and accurately is the basis for automated fire distribution and target designation capabilities anticipated in a digitally integrated force (Clark, 1993).

This suite of simulated components--CCD, POSNAV and CITV--were the core tank technologies constituting the CVCC system developed for ARI's efforts in the MWTB. Eight CVCC-equipped M1 tank simulators were configured in the MWTB to conduct ARI's company and battalion CVCC evaluations. Detailed description and iterative development of these systems during conduct of the CVCC research program is provided by Leibrecht et al. (1994).

Enabling components developed for CVCC efforts included simulated Single Channel Ground and Airborne Radio System (SINCGARS) radios and Radio Interface Units (RIUs) that modeled the media anticipated for digitally connecting main battle tanks (Greess, 1994). These radio simulators digitized and compressed speech prior to transmission and emulated the frequency-hopping pattern of actual SINCGARS radios. Interface units for each radio negotiated between voice and digital transmission while ensuring voice precedence. Simulator-based SINCGARS provided digital tank-to-tank communications for tank-based commanders, and a set of stand-alone SINCGARS afforded tank-to-TOC communications that linked these commanders with their supporting battalion staffs.

TOC workstations were also developed that furnished digitally-based planning and communication capabilities for the CVCC battalion's supporting staff. TOC workstation design and capabilities imitated the CCD's but provided separate monitors for map and communication activities. These stations supported the preparation and communication of orders, overlays, and messages to CVCC tank simulators, other TOC workstations and the TOC's Situation Display. The TOC's four CVCC workstations supported the tasks and responsibilities of the battalion's Executive Officer (XO), the assistant to the Operations Officer (S3), the Intelligence Officer (S2), and the Fire Support Officer (FSO). The large-screen Situation Display permitted posting and monitoring digital transmissions from the CVCC-equipped battlefield and, as with the CCD, visualization of the battlefield situation. An additional workstation simulated higher and adjacent headquarters communications. Detailed description (Sever & Heiden, in preparation) and utilization (Leibrecht, 1994) of these TOC workstations in CVCC research is documented.

CVCC-MWTB Integration. ARI's CVCC systems were designed to exploit the networked simulation architecture of the MWTB. The MWTB's Distributed Interactive Simulation (DIS) technology (Miller & Chung, 1987; Pope, 1987) provides a powerful test bed for soldier-in-the-loop assessment of developmental systems, and particularly

systems related to command and control performance (Alluisi, 1991; Leibrecht et al., 1994). Key features of this test bed that support research and development efforts are summarized in Table 1. Simulators in the MWTB, such as CVCC's, serve as reconfigurable weapon systems that emulate the features, capabilities and soldier-machine interfaces anticipated for developmental systems.

The MWTB simulates a multiechelon battlefield environment by means of local and long-haul networks linking families of manned simulators and semiautomated forces. The simulated battlefield's terrain-data base and weapon systems are based on a selective-fidelity design that provides the basic perceptual cues for simulating combat including visual and aural signals and effects (Chung, Dickens, O'Toole, & Chiang, 1987). Simulated cues and effects are ultimately generated by each manned simulator's host processor and computer image generator--distributed processing--and interactively shared on local- and wide-area networks that link all systems participating in the simulation.

Interactive sharing of information in this distributed network is regulated by communication protocols that control the transmission and reception of information on the simulation network. Development of CVCC protocols compatible with the simulation protocols of the MWTB provided the foundation architecture required for conduct of the CVCC research efforts (Greess, 1994). Vertical and horizontal force integration was achieved thru the MWTB's local area network (LAN) that provided connectivity between simulated CVCC systems and other MWTB assets such as computer-generated, semiautomated forces (SAFOR).

To simulate a battalion level force with only eight CVCC manned simulators, SAFOR units were an invaluable resource. Blue Forces (BLUFOR), consisting of eight manned simulators and the SAFOR vehicles under their control, comprised the battalion friendly force; the opposing force (OPFOR) was entirely simulated by SAFOR units. A critical requirement for CVCC implementation was the development of computer-generated combat reports by SAFOR to create the volume, flow and content of information within an operational battalion. These software routines automatically generated CCD-compatible reports such as Contact, Spot and Shell reports and transmitted this information on designated combat radio nets to the manned participants' CCDs. This report-generation program modeled realistic and appropriate communications with respect to each SAFOR vehicle's battlefield situation based on intervisibility, timing and nature of observed battlefield events (Greess, 1994).

A primary characteristic of simulation-based evaluation is the ability to standardize procedures and conditions while systematically manipulating variables of concern (Goldstein, 1991; Leibrecht et al., 1994). Standardization features of the MWTB include development of BLUFOR and SAFOR exercise files for routinely initializing vehicle locations and battlefield conditions, and utilities such as the report-generation software for consistent reporting by SAFOR units. Detailed descriptions are available of how these and related MWTB tools and utilities have supported structured training (Atwood, Winsch, Quinkert & Heiden, 1994; Winsch et al., 1994) and evaluation efforts (Leibrecht et al., 1994; Lickteig & Emery, 1994; O'Brien et al., 1992a).

Table 1

The Mounted Warfare Test Bed's Major Features

Features	Description
Manned simulators	Selective fidelity crewstations, with supporting hardware and software, including terrain database.
TOC workstations	Automated workstations for selected TOC staff, with supporting hardware and software, including large-screen display and screen printer.
Tactical communications	Simulated SINCGARS network for linking manned simulators, TOC workstations, and control stations; capable of both voice and digital burst transmission.
Surrogate vehicles	Semiautomated forces (SAFOR) program for creating and controlling unmanned vehicles and aircraft, both friendly and enemy; provides digital message traffic.
Scenario control	Management, Command and Control (MCC) system for initializing and monitoring manned simulators and implementing fire support. Workstation for inserting and monitoring digital messages.
Scenario monitoring	Plan View Display (PVD) providing a "bird's eye view" of a simulation exercise; supports map manipulation and event flagging. Stealth station for out-the-window viewing of the battlefield.
Data recording and analysis	Data Collection and Analysis system for on-line recording of automated data and off-line reduction and analysis; supports playback. Includes DataLogger, DataProbe™, and RS/1™ (Registered trademarks of BBN Software Products Corporation).
Utilities	Network control station, capability to save and restart exercise states, SAFOR report generation, LISTEN system to record digital messages, and playback support.

(From Leibrecht, Meade, Schmidt, Doherty, & Lickteig, 1994)

Despite its advantages, there are limitations in the MWTB's simulation of combat conditions (Leibrecht et al., 1993). Fidelity limitations related to CVCC evaluations included: an absence of open-hatch operations and dynamic terrain, visual imagery restrictions that impact target acquisition, and simulators with stationary platforms. The behavior of SAFOR units, friendly and enemy, also lacks realism with regard to their flawless identification of targets, disorderly fire control and distribution, and unrealistic navigation and maneuver patterns. Technical difficulties with the CVCC radio interfaces during the battalion evaluations required that communications be sent directly via the MWTB's Ethernet network resulting in almost immediate transmission times and error-free reception of digital reports and overlays.

Training packages and evaluation methods were developed to overcome, at least in part, many of these limitations (O'Brien et al., 1992a). For example, structured training and feedback exercises for navigating on this simulated battlefield (Atwood et al., 1994) were developed to offset potential difficulties in navigating due to visual limitations. On the other hand, a persistent concern with friendly SAFOR units is that manned simulators may attempt to navigate by following the unerring path of these semiautomated units. Experimental procedures, such as the Rules of Engagement for SAFOR operators (Meade et al., 1994), were developed to mitigate such attempts. Similarly, manning structures, such as that described in the following Participant section, assigned participants to positions that required them to direct their company's navigation and maneuver.

A detailed discussion of the MWTB limitations and their potential impact on battalion-level performance is provided by Leibrecht et al. (1994). The impact of these limitations on performance during the current evaluation of vertical integration is considered as related findings are presented in the Results and Discussion section. Significantly, most of these limitations applied equally to the CVCC and Baseline conditions and should not have affected performance differences between the two conditions.

CVCC Training, Support and Measurement. Extensive training, support and measurement packages were required for CVCC's horizontal and vertical battalion evaluations. Three days of training preceded each unit's participation in the evaluations of horizontal integration on the fourth day and vertical integration on the fifth day. Training for the subject vertical evaluation, therefore, relied heavily on the three-day package of training developed for these battalion evaluations. An overview schedule of this five day cycle, for the CVCC condition, is provided in Figure 3.

The battalion training package employed a "crawl-walk-run" model that incrementally addressed individual, crew and unit training. An overview of the activities and materials used for this structured training effort is provided by Leibrecht (1994) and more detailed descriptions of individual and crew training by Atwood et al. (1994) and unit training by Meade et al. (1994). Training materials and formats included classroom lectures, detailed training objectives, hands-on training exercises, performance-based skills tests, training feedback and debriefs.

	Day 1 Monday	Day 2 Tuesday	Day 3 Wednesday	Day 4 Thursday	Day 5 Friday
0800	1a. General Introduction	2a. Crew Assignments 2b. General Introduction (Gnrs/Dvrs)	3a. Bn STX Pre-Brief & Prep	4a. Horizontal Integration Evaluation (HI) Test Scenario Pre-Brief and Prep	5a. Vertical Integration (VI) Evaluation Pre-Brief and Prep
0900	1b. CCD Demonstration	2c. CTV Skills Test 2d. Gunners/Drivers Sim Orientation	3b. Bn STX	4b. HI Test Scenario	5b. VI Tng Event A
1000	Break	2e. Veh Cdr/BLUFOR Operator Coordination Break	Break	Break	5c. Bn OPORD briefing/Planning
1100	1c. Vehicle Commander Seat-Specific Training	2f. Tank Crew Training	3c. Bn STX Debrief	4b. HI Test Scenario (Cont.)	5d. VI Tng Event B
1200	1d. CCD Training	Break	3d. CCD Refresher Training	4c. HI Situational Assessment	Break
1300	LUNCH	LUNCH	OFFICERS CALL	LUNCH	LUNCH
1400	1d. CCD Training (Cont.)	2g. Co STX Pre-Brief	3e. Bn TNG Scenario Pre-Brief and Prep	4b. HI Test Scenario (Cont.)	5f. VI Test Event 2
1500	1e. CCD Skills Test	2h. Co STX	3f. Bn TNG Scenario	4c. HI Situational Assessment	5g. VI Test Event 3
1600	1f. CTV Training	2i. Bn Staff Situational Training (Cont.) 2j. Co STX Debrief	3g. Situational Assessment 3h. Bn TNG Debrief	4d. HI Test Scenario Debrief	Break
1700		2h. Co STX (Cont.) Break	3i. Bn TNG Scenario (Cont.)	4e. Training Assessment	5h. VI Test Event 4
		2j. Co STX Debrief	3g. Situational Assessment	4f. SMI Evaluation	Break
			3h. Bn TNG Debrief	4g. VI Overview Briefing	5i. VI Debrief

☐ = Training  
☐ = Testing

Figure 3. Training and evaluation schedule (Adapted from Leibrecht, Meade, Schmidt, Doherty & Lickteig, 1994).

A foremost concern in developing this training package was to provide equivalent training for CVCC and Baseline conditions despite inherent differences in content due to equipment variations. In particular, individual training differed between the CVCC and Baseline conditions. Special training on the use of the CCD and CITV for CVCC commanders was offset, at least in intent, by providing special training on MWTB navigation to Baseline commanders. Crew training employed an "electronic sandbox" that required each crew to navigate a designated route while identifying, engaging and reporting targets systematically located along the route. Unit training included three progressive phases: a company situational training exercise (STX), a battalion STX and a battalion training scenario. The basic training objectives for crew and unit training were identical for each condition and the training exercises provided analogous opportunities to rehearse the performance of common tasks using different C<sup>2</sup> systems.

An extensive support package was developed for CVCC's battalion training and evaluation efforts (Leibrecht et al., 1994). All unit training and test exercises were supported by detailed overlays, operations orders (OPORDs), scenario events lists, initialization files for manned and SAFOR units, and SAFOR scenario execution files. This support package included the battalion's Standing Operating Procedure (SOP) that imposed common standards for maneuver, engagement and communication such as report content and format. Additionally, two types of guidelines were developed for researchers and staff. The Rules of Engagement specified control procedures such as voice radio protocols for SAFOR operators; and the Contingency Rules specified the decision process and options for consistent handling of technical and personnel problems (Meade et al. (1994). This structured and detailed support package reduced extraneous variation between and within conditions while providing comparable preparation and execution of battalion-level assessments.

The measurement package developed for CVCC evaluations included automated and manual data capture methods that exploit the MWTB's unique assets for monitoring and recording battlefield performance (see Table 1). Development of these measures was driven by the need to provide empirical and practical data on the potential implementation of such systems in combat vehicles. Detailed descriptions are available that document MWTB Baseline measurement methods (Elliott and Quinkert, 1993) and the set of measures and operational definitions used for CVCC's battalion evaluations in this test bed (Leibrecht et al., 1994; O'Brien et al., 1992b).

The MWTB's primary measurement asset is a Data Collection and Analysis (DCA) system that provides automated data recording, reduction, management, and analysis capabilities (BBN, 1991). The DCA's DataLogger records and time-stamps all data packets transmitted over its Ethernet network. Data packets include simulator appearance packets specifying vehicle location, orientation and status as well as CVCC instrumentation packets such as CCD report content, transmission and reception and CITV lases and orientation. Reduction and management of the voluminous DataLogger files captured from the Ethernet are performed by a DataProbe™ utility that extracts and structures prespecified data packets. Stock analyses are based on the MWTB's library of analytic routines for standardized output; customized analyses are based on operational

definitions provided for the subject evaluation. Analyses performed at the MWTB rely primarily on a DCA statistical package titled RS/1™, but files may be exported to other statistical packages such as the Statistical Package for the Social Sciences (SPSS) (RS/1™ and DataProbe™ are registered trademarks of BBN Software Products Corporation).

Manual inputs into automated DataLogger recordings can be made from an MWTB tool called the Plan View Display (PVD) that provides an overhead "bird's-eye view" of the simulated battlefield during training and evaluation exercises. For CVCC's battalion evaluations, two PVD stations in an exercise control room were used to embed event flags in the DataLogger recordings. These flags indicated the timing of key events, as observed by researchers, such as the start of an exercise, the crossing of a phase line or seizure of a battlefield objective. More traditional manual data collection instruments developed for CVCC included skills tests, a biographical questionnaire, and data-collection logs for PVD, TOC and SAFOR operators.

#### Current Research Requirement: Vertical Integration of an Armor Battalion

As reviewed, the general research requirements for evaluating the effects of digital C<sup>2</sup> systems in an armor force lead to development of simulation-based CVCC components and capabilities, a CVCC system architecture compatible with the MWTB's distributed network, and detailed training, support and measurement packages. ARI's initial assessments of automated C<sup>2</sup> systems had demonstrated significant improvement in command and control performance at the crew, platoon, and company level. The prior battalion-level assessment of horizontally linked digital C<sup>2</sup> systems had demonstrated that by digitally linking company and battalion command groups, the CVCC-equipped units demonstrated significantly better performance with respect to synchronized movement, extended fire ranges, accelerated threat acquisition and mission execution.

An important and unanswered question, within the scope of CVCC's battalion-down assessments, was the effect of vertical C<sup>2</sup> system integration on a battalion's operational effectiveness. The Army requirement for full force digital integration would be bolstered by an empirical assessment which demonstrated that the vertical linkage of echelons in a combat unit increased operational effectiveness and C<sup>2</sup> capability.

This research requirement to evaluate the effects of vertically integrated digital C<sup>2</sup> systems raised numerous empirical and practical questions. What is the operational effect of providing digital C<sup>2</sup> capabilities simultaneously at crew, platoon, company and battalion levels? Would the bottom-up communication of combat reports using C<sup>2</sup> digital systems provide more timely, accurate and complete information on the status of enemy and friendly units to battalion command groups and staffs? Would the top-down communication of orders, overlays and intelligence reports using digital C<sup>2</sup> systems result in faster and more accurate reception of this information? Would the reception of this information in graphic and map-based formats improve the unit's ability to maneuver, engage targets, and execute the missions assigned?

## Objectives, Issues, and Hypotheses

The primary objective of this effort was to evaluate the effect of vertically integrated digital C<sup>2</sup> systems on the combat performance of an armor battalion. Supporting objectives were to systematically evaluate this effect on key battlefield functions critical to combat effectiveness under related Battlefield Operating Systems (BOS). Research issues, therefore, were based on the Blueprint of the Battlefield that doctrinally established the primary functions for each BOS. Four BOS systems were selected as appropriate for this evaluation: Maneuver, Fire Support, Command and Control, and Intelligence. Research issues were formulated to determine the effect of vertically integrated digital C<sup>2</sup> systems on key battlefield functions within an armor battalion underlying each BOS selected.

Hypotheses of enhanced performance by CVCC-equipped units were based on the Army's expectations for automated C<sup>2</sup> systems and ARI's prior research efforts, as reviewed. The operational concept for such systems hypothesized that they would prove a significant force multiplier in battalion operations, and proponents urged that the vertical integration of echelons within a unit was key to victory on the future battlefield. This evaluation hypothesized that an armor battalion with CVCC-based digital connectivity of own echelons would perform significantly better than a Baseline unit using conventional C<sup>2</sup> equipment. The expectation of improved performance was generalized across each BOS tested and to the combat functions selected under each BOS that appeared related to automated C<sup>2</sup> system capabilities. A detailed set of the combat functions and tasks tested by BOS are presented in the Performance Measures section of this report. For the Command and Control BOS, for example, expectations of improved performance by combat function included the ability to receive and transmit the mission; receive and transmit enemy information; receive and transmit friendly troop information; and manage means of communicating information.

## Method

The method was based on a series of Data Collection Exercises (DCEs), sometimes referred to as mission segments or vignettes, designed to standardize battlefield conditions and participants' battlefield placements at critical points and times (Lickteig, Williams, & Smart, 1992). Structuring of these exercises required many of the MWTB "tools" developed and refined during the course of ARI's CVCC research efforts such as automated battlefield reporting, teleportation of simulators, and "slice" manning configurations augmented by semiautomated forces (Atwood et al., 1994). This method also relied heavily on the CVCC training, support and measurement packages, previously described. The method provides an example of how simulation-based technologies can meet future C<sup>2</sup> training and evaluation requirements.

## Participants

Participants for the evaluation were 209 U.S. Army personnel and one U.S. Marine who were active duty soldiers stationed at Fort Knox, Kentucky. This all male

sample included 71 commissioned officers and 139 non-commissioned officers (NCOs) and enlisted personnel with ages ranging from 18 to 43 years. All participants held an armor Area of Concentration or were currently qualified in armor Military Occupational Specialties (MOSs). The standard test group for each evaluation week consisted of 24 participants, eight officers and sixteen NCOs or enlisted personnel, provided by supporting units.

For each test group, the officers were assigned as follows: one served as the battalion commander and one as the battalion's S3 of Operations; one served as company commander for B ("Bravo") Company and one as this company's XO; the remaining four officers served as platoon members of 1st Platoon, B Company and included the platoon leader, platoon sergeant and two wingmen tank commanders. Assignments were based on participants' rank and experience in relevant duty positions, and the battalion commander's judgment. Enlisted personnel served as gunner and driver for each of the eight crews and were assigned by the battalion commander. In general, crew membership was ad hoc and the members had not worked together before.

In one CVCC test week, an S3 was not available and his crew was dropped from the evaluation. In one of the Baseline test weeks, only seven gunners were available so the S3's crew operated without a gunner. One enlisted person was inadvertently allowed to serve in two separate test weeks.

Vertical-Slice Battalion Configuration. Configuration of the BLUFOR test battalion required a mix of simulators, manned each week by the group of test participants, and friendly SAFOR units as shown in Figure 4. Participant assignment to the eight simulators targeted key duty positions that enabled soldier-in-the-loop assessment at battalion, company and platoon levels. Assignments for these echelons are indicated in Figure 4 where duty positions are identified by each commander's "call sign" such as "Y06" for battalion commander, "B06" for B Company commander, and "B11" for the platoon leader of 1st Platoon, B Company.

The battalion's remaining combat vehicles--three companies, two platoons of B Company, and the scout platoon--were represented by SAFOR elements controlled by participant commanders and operated by role-playing test personnel. The overall force structure modeled was a tank-pure armor battalion composed of four tank companies, a six-vehicle scout platoon, and a command group located at the TOC. The OPFOR consisted entirely of SAFOR units under the control of test support personnel.

The evaluation's emphasis on soldier performance extended to the battalion SOP that directed execution of the training and test exercises. This SOP assigned the designated manned platoon, B Company's 1st Platoon, to serve as the point element directing their company's navigation and maneuver. Figure 5 illustrates one such B Company formation dictated by this SOP that encompassed all B Company formations appropriate to the evaluation's training and test exercises.

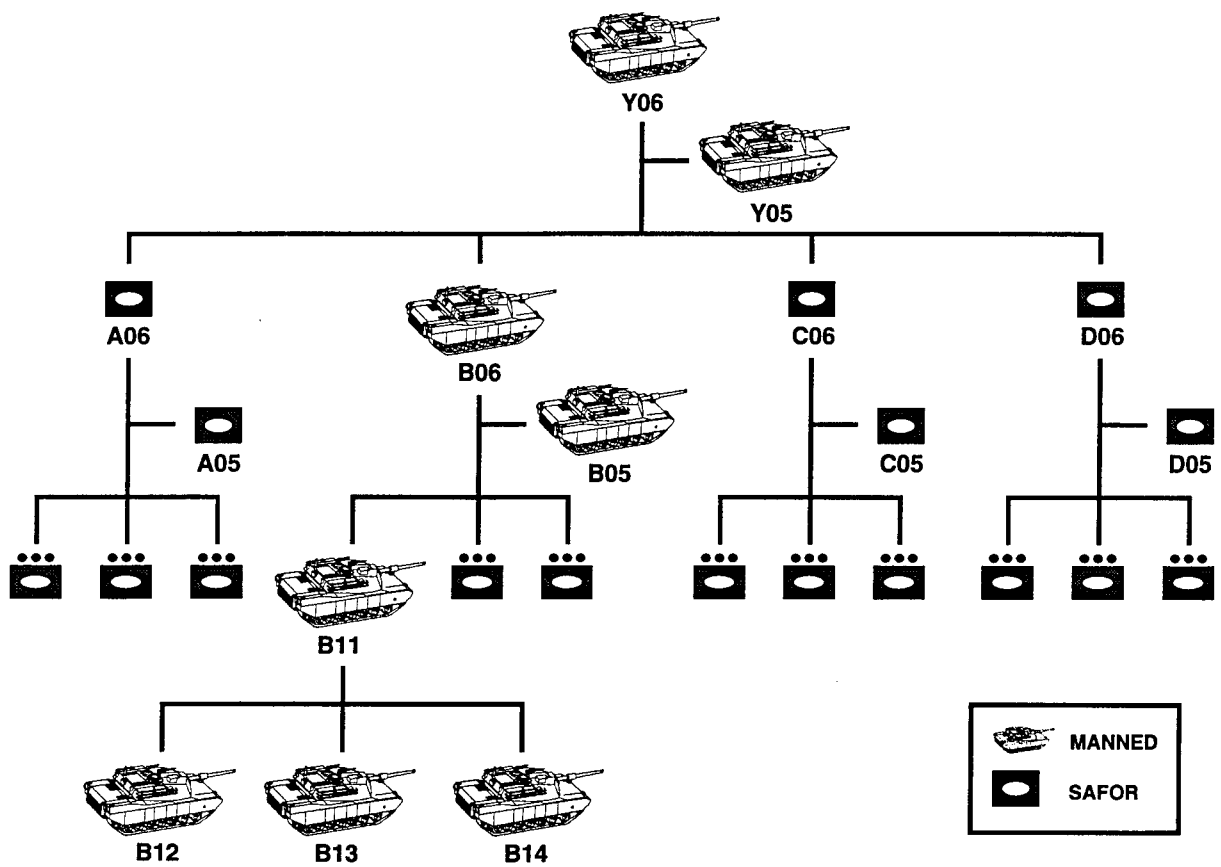

Figure 4. Vertical slice battalion manning structure.

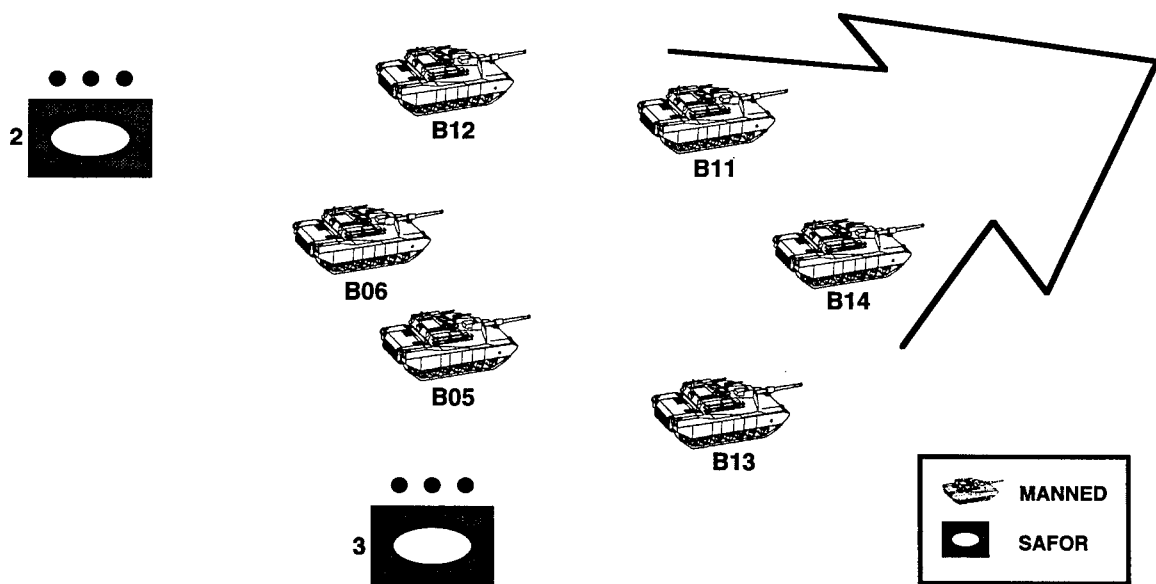

Figure 5. B Company wedge formation, 1st Platoon on point, based on Standard Operating Procedure (SOP).

Support Personnel. Conduct of ARI's horizontal and vertical battalion evaluations relied on a cadre of contracted support personnel. The primary roles and responsibilities of these personnel were to serve as the battalion's staff in the TOC, to direct and control training and test exercises from the Exercise Control Room (ECR), and to train participants and monitor their performance in the simulators. Detailed descriptions of the roles and responsibilities of these personnel are provided by Leibrecht et al. (1994).

TOC staff members served as an integral part of the battalion organization and role-played the positions of battalion XO, assistant S3, S2, and FSO. The same staff members supported the CVCC and Baseline conditions during each test week. This permanent staff standardized TOC functionality and maintained CVCC's emphasis on tank-based automated C<sup>2</sup> systems. The staff used CVCC's automated TOC workstations augmented by voice radio when supporting the CVCC condition, and conventional C<sup>2</sup> aids such as paper maps and acetate with voice-only communications when supporting the Baseline condition.

Exercise control personnel trained the participants, directed and controlled all exercises, and operated MWTB stations in the ECR. The Exercise Director and Battle Master jointly provided direction and control of all training and test exercises in a manner consistent with the evaluation plan and the support package's battalion SOP, Rules of Engagement and Contingency Rules (Meade et al., 1994). Exercise control staff also conducted mission briefs and debriefs, coordinated data collection, and role-played communications from higher and adjacent unit commanders and staffs.

SAFOR operators, for both BLUFOR and OPFOR units, activated standard initialization files prior to each exercise and coordinated their units' actions with the Battle Master during each exercise. BLUFOR operators executed the orders and requests received over voice-radio from participant commanders who directed the activities of their friendly SAFOR units. For the Baseline condition, BLUFOR operators and supporting personnel role-played the voice-communications appropriate between friendly SAFOR units and their participant commanders. For the CVCC condition, the SAFOR's report-generation software automatically transmitted comparable communications from the SAFOR units directly to participant commanders' CCDs.

Research Assistants (RAs) assigned to each simulator trained commanders and their crews during the training exercises. During training and test exercises, RAs monitored and reported equipment malfunctions and participant problems or issues.

### Apparatus

The primary apparatus used for this evaluation were eight CVCC simulators and the automated TOC, and their Baseline counterparts. Additional MWTB test facilities used were a suite of workstations in the ECR for monitoring and controlling simulation exercises, and the DCA system for collecting and analyzing performance data. Although briefly described in this section, detailed descriptions of all equipment and facilities used are provided by Leibrecht et al. (1994) and O'Brien et al. (1992a).

The eight MWTB Baseline tank simulators used in the evaluation were enhanced versions of the standard M1 tank simulator developed for SIMNET and described in the M1 SIMNET Operator's Guide (U.S. Army Armor School, 1987). Based on a selective fidelity design, these simulators provided the basic move, shoot and communicate functionality required for unit and C<sup>2</sup> training (Alluisi, 1991). Collective realism was maintained by each simulator's ability to generate and distribute to others the visual and aural cues of interactive combat such as vehicle appearance and movement, weapon firing and impact, and voice-based communications. Baseline simulator enhancements were voice-only SINCGARS radios, a gunner's Thermal Imaging System (TIS), and a simulated autoloader that replaced the tank's fourth crew member, the loader.

The eight CVCC tank simulators used in the evaluation were the same MWTB simulators used for the Baseline condition but enhanced by the functionality provided by the CVCC components. The capabilities of a CVCC simulator, previously described and referenced, are summarized and compared with the Baseline simulator in Table 2. During CVCC test weeks, the CCD, POSNAV and CITV components in each simulator (see Figure 1) were uncovered and activated. During Baseline test weeks, the CVCC system components, located in these simulators, were concealed and disabled. During all test weeks, manned simulators used by both conditions were protected by a "kill suppress" feature that overrode damaging or disabling direct and indirect fire effects. Kill suppress, used in most of ARI's CVCC evaluations, was employed to ensure that connectivity conditions within and between echelons were standardized.

CVCC software used for the evaluation was Version 1.9 which equated to the "Version 7.0" that appeared on each CCD at initialization (Greess, in preparation). This software version supported commanders' CCD-based preparation and communication of the following "named" reports: Contact, Call For Fire (CFF), Adjust Fire, Spot, Shell, Situation, Intelligence, and NBC (Nuclear/Biological/Chemical). It supported the TOC's preparation and transmission of fragmentary orders (FRAGOs), FREE TEXT reports and overlays to CCD-based commanders. It also supported generation and transmission of Contact, Spot, Shell and Situation reports by friendly SAFOR units to CCD-based commanders. CCD formats for these reports are provided by Leibrecht et al. (1994).

CVCC and Baseline TOCs were located in a Standard Integrated Command Post System (SICPS) tent, adjacent to the simulators in the MWTB's simulation bay. The Baseline TOC provided conventional C<sup>2</sup> equipment such as wall charts, paper maps, journals and the following voice radio nets: brigade command, brigade operations and intelligence (O&I), battalion command and battalion O&I. The CVCC TOC with its automated workstations and Situation Display relied on digital and voice nets for communications with the battalion's simulator-based participants and supporting notional units.

Equipment for conduct and control of the training and test exercises (see Table 1) was located in the MWTB's ECR, adjacent to the simulation bay. Primary equipment items were the simulator and simulation exercise control stations, two PVDs, SAFOR workstations for friendly and opposing forces, and an automated TOC-like workstation

Table 2

## Comparison of Baseline and CVCC M1 Simulator Functions

	Baseline	CVCC
<u>Navigation</u>		
Out-the-window views (vision blocks)	X	X
Paper map with overlays	X	X
Odometer	X	X
Grid azimuth indicator	X	X
Turret-to-hull reference display	X	X
Main gun laser range finder (LRF)	X	X
CCD tank icon and status information		X
Digital terrain map and tactical overlays		X
Digital navigation routes		X
Driver's navigation display		X
<u>Target acquisition and engagement</u>		
Out-the-window views (vision blocks)	X	X
Gunner's Primary Sight/Extension with thermal, magnification, main gun LRF	X	X
Turret-to-hull reference display	X	X
Autoloader with 8-second reload cycle	X	X
40-round basic load (27 SABOT, 13 HEAT)	X	X
CITV with LRF, Identification Friend or Foe, 3 scan modes, magnification, polarity		X
CITV target designate		X
<u>Communications</u>		
Radio intercom	X	X
SINGARS radios (voice communication)	X	X
SINGARS radio interface unit (data communication)		X
Digital combat report communication		X
LRF/location input to combat reports		X
Digital tactical overlay communication		X
Digital navigation route communication		X

(From Leibrecht, Meade, Schmidt, Doherty, &amp; Lickteig, 1994)

for digital communications between the TOC and the ECR's notional brigade and adjacent units. In addition, the ECR had six stand-alone SINCGARS radio simulators for tactical voice and digital communications with test participants and the TOC, and two separate "nets" for administrative communications with the TOC and RAs.

The primary data collection apparatus was a DataLogger that recorded the network's data traffic including event flags from the PVDs, in the ECR. Data reduction and management facilities relied on the DCA assets, previously described. The ECR's SINCGARS and PVDs were used for replaying voice and visual recordings that allowed RAs to transcribe the voice communications from Baseline and CVCC test exercises.

### Training and Test Materials

The training materials for this evaluation relied heavily on the training package, previously described and referenced, that was developed for ARI's battalion evaluations. This package included the structured exercises, Figure 3, and materials used for training individuals, crews and units for CVCC and Baseline conditions. After participants completed the test exercises and requirements for the evaluation of a horizontally integrated armor battalion, training commenced for the evaluation of vertical integration. This training began with an overview brief to each week's test participants that addressed the nature and purpose of the upcoming vertical evaluation. This brief explained that the tactical setting comprised a series of exercises developed to assess the ability of a battalion to conduct high-tempo operations on a dynamic battlefield.

The nature and purpose of the two training and four test exercises used during the course of this evaluation are outlined in Table 3. It identifies the specific cuing events used to trigger the FRAGOs that forced impromptu changes in the battalion's Movement to Contact mission (see Appendix C). Some cues, such as contact with enemy forces, originated at the platoon level and required communication of this information, up the vertical command structure, to company and battalion echelons. Other cues originated at higher echelons and required top-down communications to inform company and platoon echelons (see Appendix D).

The introductory brief stressed that training exercises were designed to reinforce the "train as you fight" model and were structured the same as test exercises. Table 4 identifies the typical sequence of events for each exercise. After the unit's battlefield orientation, the first key event was the initiating cue. This cue eventuated in the issue of a FRAGO that the unit was required to execute for the duration of the exercise. Exercises were completed when the FRAGO was completely executed or when the time allotted for the exercise, 25- to 35-minutes, had expired.

The overview brief then described the manning structure, Figure 4, required for ensuring vertical linkages between battalion, company and platoon echelons. To achieve this structure, the participant company commanders and XOs from A and C Companies, during the horizontal evaluation, roleplayed as the platoon leader, platoon sergeant and wingmen for 1st Platoon, B Company during this evaluation. Supporting radio net

Table 3

Overview of Training and Test Exercises

Purpose	Description	Cue Event	Routing	FRAGO
Training	Cross-reinforce	Brigade order	Top down	Overlay
Training	Bypass enemy	Intelligence	Top down	Overlay
Evaluation	Assault enemy	Intelligence	Top down	Overlay
Evaluation	Enemy flank attack	Enemy fire	Bottom up	Oral
Evaluation	Abort an attack	Friendly loss	Bottom up	Oral
Evaluation	Pressured withdraw	Intelligence	Top down	Overlay

Note. Fragmentary Order (FRAGO).

structures and call signs for these new duty positions were identified and graphically illustrated during the overview brief.

The evaluation's emphasis on soldier-in-the-loop performance was stressed as this brief addressed manning structure, company formations and performance measures. Company formations were described and illustrated that required 1st Platoon, B Company to lead their company's navigation and maneuver activities, Figure 5. SOP guidelines were provided such as cross-country movement speed at 20 km/hr, road march speed at 50 km/hr and 100-meter vehicle dispersion within the platoon. Key performance measures were emphasized including FRAGO response time, navigational accuracy, and communication speed and accuracy across echelons. The overview brief concluded with a preview of the training objectives for the next day's training exercises.

Prior to conduct of each training exercise, participants were extensively briefed on its training objectives, Table 5. The training exercises were developed to provide repeated opportunities for these vertically structured units to practice reporting, navigation and maneuver procedures. Logs for the training exercises were developed and used to provide detailed feedback, after each training exercise, on the unit's ability to meet their training objectives.

The training and test exercises were based on a Movement To Contact (MTC) scenario developed with the assistance and approval of the Directorate of Combat Developments (DCD), U.S. Army Armor School, Fort Knox, Kentucky. Guided by this MTC scenario, the research objectives, and the manning structure available for vertical

Table 4

## Typical Scenario Sequence for Training and Test Exercises

Time	Event	Activity
T-5 min	Exercise orientation	Situation update
T-0 min	Exercise started	"REDCON 1": Begin execution
T+5 min	Initiating cue	Intelligence report or enemy contact
T+5-10 min	FRAGO issued	Execute FRAGO
T+30 min	Exercise completed	"Cease fire, freeze"

Note. Actual times (T = start time), events and activities varied by exercise.

evaluation, armor subject matter experts developed the training and test exercises used in this evaluation.

The operational overlay for the basic MTC scenario is provided in Figure 6. The OPORD for this mission directed the battalion use a diamond movement formation that positioned each of the battalion's four companies at a diamond point with B Company on the right flank, Appendix B. Exercise design ensured that the FRAGOs and their cuing events were directed at the participants, B Company and its 1st Platoon. For example, Figure 7 illustrates the FRAGO overlay for the first test exercise, Assault from MTC. This order required B Company to maneuver along Axis Green, seize Objective Oak and rejoin the battalion at Objective Tin. Exercise development included a detailed list of operational events tailored to meet the exercise structure and evaluation objectives. Event lists for all exercises are provided in Appendix A.

### Performance Measures

The performance measures used for the evaluation were based on the set of measures developed during the course of ARI's simulation-based research on automated C<sup>2</sup> systems (Leibrecht et al., 1993, 1994; O'Brien et al., 1992a). The overall set of measures addressed operational effectiveness, training requirements and soldier-machine-interface design; this evaluation used only measures of operational effectiveness. Performance settings were designed to ensure soldier-in-the-loop objective measures in realistic and demanding operational scenarios. Measures were structured by relevant BOS and combat functions to provide empirical findings in a meaningful format.

For this evaluation, the measures addressed relevant combat functions under the tactical BOS of Maneuver, Fire Support, Command and Control, and Intelligence.

Table 5

Objectives for the Training Exercises

---

First Training Exercise (A)	
1.	Practice tactical movement within the exercise structure: <ul style="list-style-type: none"><li>● 1st Plt B - internal coordination</li><li>● Coordination between manned and automated platoons and companies</li></ul>
2.	Communicate using the revised radio net structure: <ul style="list-style-type: none"><li>● "A" and "B" nets</li><li>● Assigned duty position</li></ul>
3.	Practice land navigation with 1st platoon B on the point: <ul style="list-style-type: none"><li>● Maintain speed and dispersion</li><li>● Maintain company formations</li></ul>
4.	Practice reporting procedures on battalion, company and platoon nets.

---

Second Training Exercise (B)	
1.	Reinforce procedures for manning and radio net structures.
2.	Reinforce tactical movement based on standard operating procedure: <ul style="list-style-type: none"><li>● Emphasize actions on contact.</li></ul>
3.	Reinforce reporting procedures: <ul style="list-style-type: none"><li>● Process Fragmentary Orders up and down the chain of command</li><li>● Process Contact and Spot reports</li></ul>

---

Figure 8 illustrates the organization of selected combat functions under the Command and Control BOS. Measures used to assess the impact of vertical integration on an armor battalion's ability to receive and transmit mission information are highlighted in Figure 8. Measures were designed to assess vertical integration effects at each echelon and cumulative effects across echelons. A complete set of the measures obtained during the evaluation are provided in Table 6 and the basis of each measure is described before findings are reported in the Results and Discussion section. Operational definitions for these measures are provided by Leibrecht et al. (1994) and O'Brien et al. (1992a).

Procedure

The current evaluation of vertical integration was initiated upon completion of all requirements for the horizontal evaluation, as previously stated. Procedures followed for



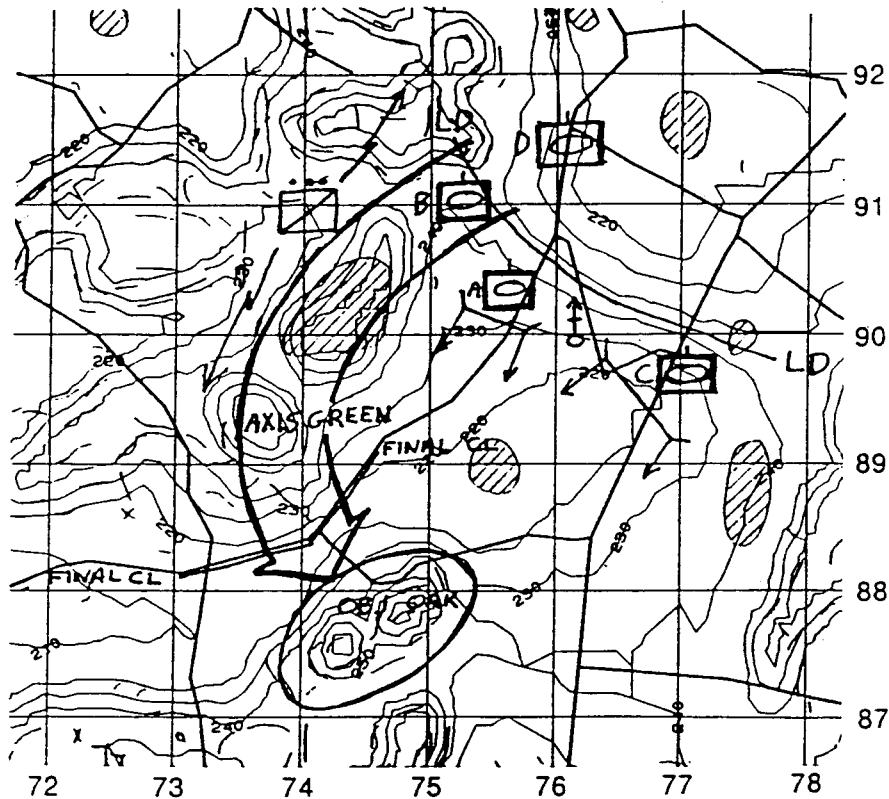

Figure 7. Operational overlay for fragmentary order, Assault from Movement to Contact.

the horizontal evaluation were instrumental in preparing participants for the current evaluation. In particular, the procedures used to train participants' C<sup>2</sup> task execution on a simulated battlefield provided essential groundwork for their participation in this evaluation. For a detailed description of the procedures prior to the vertical evaluation, see Leibrecht et al. (1994) and Atwood et al. (in preparation).

Procedures for the vertical evaluation began with the overview brief on its nature and purpose. This brief was typically scheduled as this last event on day four, see Figure 3. This classroom orientation, provided by support personnel, employed scripted lecture and slides that verbally and graphically previewed key evaluation issues. These issues included: exercise design and operational setting, manning and communication structures, SOPs and performance measures. Questions were encouraged and answered. With the exception of the battalion commander and his XO, participants were released for the day upon completion of this overview brief.

The battalion commander and his XO were given an extended brief that requested their compliance in issuing the warning orders and FRAGOs already developed for training and test exercises. Rationale for their compliance stressed the need for standardized exercises to ensure that cuing events and performance requirements remained constant throughout all test weeks. In essence, they were asked to defer their C<sup>2</sup> role as a decision-making commander and reinforce their roles as

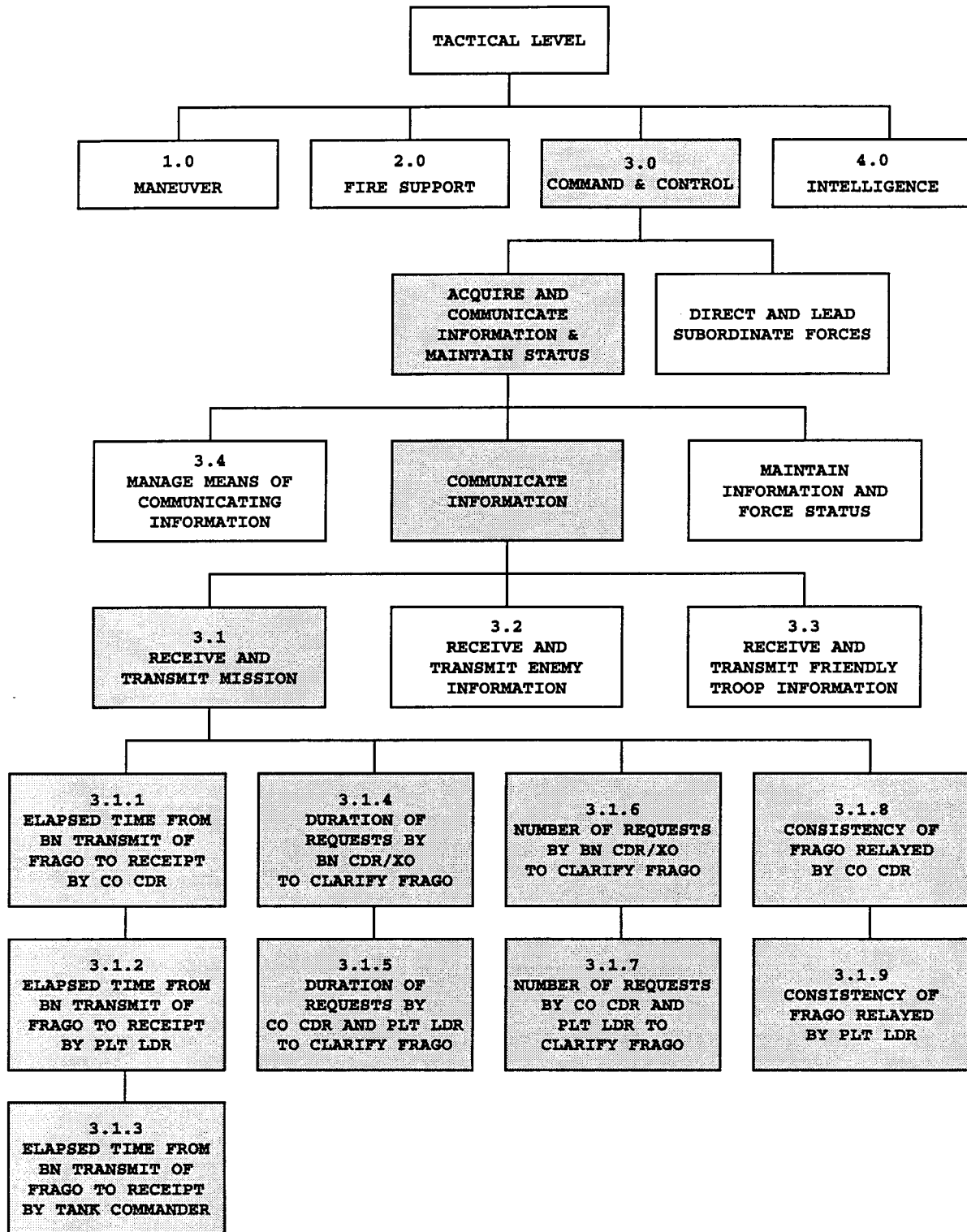

Figure 8. Measures for receive and transmit mission based on tactical command and control battlefield operating system (Adapted from Blueprint of the Battlefield (U.S. Army Training and Doctrine Command, 1991)).

Table 6

Performance Measures by Battlefield Operating System (BOS) and Combat Functions

---

1.0 Maneuver BOS	
1.1 Move on the Surface	
1.1.1	Exposure to opposing force (OPFOR).
1.1.2	Range to OPFOR at displacement.
1.1.3	Number of manned platoon vehicles < 100 meters apart.
1.1.4	Number of manned platoon vehicles > 100 and < 200 meters apart.
1.1.5	Number of manned platoon vehicles > 200 meters.
1.1.6	Number of exercises completed within time.
1.1.7	Exercise time.
1.1.8	Distance from scripted end-point of exercise.
1.3 Navigate	
1.3.1	Percentage of time spent at a halt.
1.3.2	Velocity while moving.
1.3.3	Percentage of time moving velocity exceeded 40 km/hr.
1.3.4	Distance travelled.
1.3.5	Fuel used.
1.3.6	Time spent out of sector, beyond axis, or misoriented.
1.4 Process Direct Fire Targets	
1.4.1	Time to acquire targets.
1.4.2	Time between lases to different targets.
1.4.3	Time from lase to first fire.
1.4.4	Maximum lase range.
1.4.5	Number of fratricide hits by manned vehicles.
1.4.6	Number of fratricide kills by manned vehicles.
1.5 Engage Direct Fire Targets	
1.5.1	Losses/kills ratio.
1.5.2	Target hit range.
1.5.3	Target kill range.
1.5.4	Percentage OPFOR vehicles killed by all manned vehicles.
1.5.5	Hits/round ratio, manned vehicles.
1.5.6	Kills/hit ratio, manned vehicles.

(table continues)

Table 6 (Continued)

1.5 Engage Direct Fire Targets, cont.

- 1.5.7 Kills/round ratio, manned vehicles.
- 1.5.8 Number of manned vehicles sustaining a killing hit .
- 1.5.9 Number of rounds fired by manned vehicles.

---

2.0 Fire Support BOS

---

2.1 Process Ground Targets

- 2.1.1 Accuracy of Call For Fire (CFF) locations.
- 2.1.2 Number of scorable CFFs.
- 2.1.3 Percentage of CFFs with correct type.

---

3.0 Command and Control BOS

---

3.1 Receive and Transmit Mission

- 3.1.1 Time to transmit fragmentary order (FRAGO) from Battalion (Bn) to receipt by company commander (Co Cdr).
- 3.1.2 Time to transmit FRAGO from Bn to receipt by platoon leader (Plt Ldr).
- 3.1.3 Time to transmit FRAGO from Bn to receipt by tank commander.
- 3.1.4 Duration of request by Bn Cdr/XO to clarify FRAGO or overlay.
- 3.1.5 Duration of request by Co and Plt to clarify FRAGO or overlay.
- 3.1.6 Number of requests by Bn Cdr/XO to clarify FRAGO or overlay.
- 3.1.7 Number of requests by Co Cdr and Plt Ldr to clarify FRAGO or overlay.
- 3.1.8 Percentage of FRAGO elements correctly relayed by Co Cdr.
- 3.1.9 Percentage of FRAGO elements correctly relayed by Plt Ldr.

3.2 Receive and Transmit Enemy Information

- 3.2.1 Time to relay Contact reports.
- 3.2.2 Time to relay Spot reports.
- 3.2.3 Time to relay Shell report.
- 3.2.4 Number of bottom-up enemy reports relayed.
- 3.2.5 Duration of requests to clarify INTEL report.
- 3.2.6 Number of requests to clarify INTEL report.
- 3.2.7 Percentage of INTEL report elements correctly relayed.

(table continues)

Table 6 (Continued)

### 3.3 Receive and Transmit Friendly Troop Information

- 3.3.1 Deviation of BLUFOR location in SITREP.
- 3.3.2 Delay between observed and reported checkpoint crossing.
- 3.3.3 Number of voice communications between Bn echelon and Tactical Operations Center (TOC), nonnamed reports.
- 3.3.4 Duration of voice communications between Bn echelon and TOC, nonnamed reports.

### 3.4 Manage Means of Communicating Information

- 3.4.1 Duration of voice radio transmissions.
- 3.4.2 Number of voice transmissions, nonnamed reports.
- 3.4.3 Net time on voice radio.
- 3.4.4 Number of named voice reports.

---

## 4.0 Intelligence BOS

---

### 4.1 Collect Threat Information

- 4.1.1 Accuracy of Contact report locations.
  - 4.1.2 Accuracy of Spot report locations.
  - 4.1.3 Accuracy of Shell report locations.
  - 4.1.4 Percentage of Contact reports with correct type.
  - 4.1.5 Correctness of Spot report number by type.
  - 4.1.6 Number of scorable Contact reports.
  - 4.1.7 Number of scorable Spot reports.
  - 4.1.8 Number of scorable Shell reports.
- 

controller and communicator for the exercises' standardized plans and orders. All of these participants concurred with this request.

Training continued, the next morning, with an exercise prebrief that more extensively reviewed the issues addressed during the overview brief. In particular, this prebrief addressed the training objectives for the first training exercise and participants' orientation to this exercise. Participants were again encouraged to ask for clarification on any issues discussed, or overlooked, that appeared pertinent to the upcoming training and test exercises. The MTC mission brief (see Appendix B) and operational overlay, Figure 6, were provided to set the operational context for the exercises. At the completion of this brief and prior to "mounting" their simulators, each group was allotted approximately 20 minutes to review the mission and copy any additional graphics onto the map boards and acetate sheets provided to both conditions.

After each training exercise, debriefs provided specific feedback on the unit's ability to meet the training objectives for that exercise. These debriefs were conducted by the Battle Master and occurred in an area of the simulation bay that was adjacent to the simulators. This feedback was based on the logs maintained by the Battle Master and SAFOR operators, and it systematically reviewed performance on each training objective. Participants comments and questions were addressed and techniques for meeting these objectives were routinely provided to both conditions.

Prior to each exercise, projected times were posted, or reported over voice radio, for the following exercise events: mounting the simulators, exercise orientation, and exercise start. Simulators and SAFOR units were also initialized at prespecified locations (see Appendix A) prior to each exercise. Such relocations were generally minor, 1 to 2 km, and afforded standardized start locations across conditions and test weeks. Orientation periods preceded the start of all exercises to familiarize participants with their current operational setting. This orientation period provided time for participants to determine their location, to conduct communication "checks" to ensure their assigned voice and/or digital SINCGARS nets were operative, and to verify the relative location of other manned simulators and friendly SAFOR units. Verification generally included requests between participants and SAFOR operators to move a simulator or one of its components, such as the gun tube, to visually confirm the identity of selected simulators or units.

For Baseline units, the instructions for each exercise provided only general location information that stated B Company was located "in the vicinity of" a nearby control measure, provided on the original MTC operational overlay. Baseline participants who wanted to know their precise simulator location were required to determine location in a manner, such as map-terrain association, similar to commanders of conventional combat vehicles. As noted, Baseline participants had already received additional training on simulation-based, location-determination and navigation procedures (Atwood et al., 1994). In contrast, CVCC participants were provided continuous POSNAV updates on their simulator's location by their CCDs (see upper-right corner of Figure 2). As notionally illustrated in Figure 2, their CCDs also depicted the relative locations and call signs of other CVCC participants' simulators and the battalion's friendly SAFOR units.

When participants reported "REDCON 1" over voice radio to signify they were ready, the Battle Master responded "Begin execution" and the exercise was officially started. Events controlling the exercise such as enemy contacts, intelligence reports, warning orders and fragmentary orders were based on the structured event lists (Appendix A) that included anticipated actions and locations of the test unit. During the exercises, participants were expected to navigate and maneuver in accordance with the orders issued and the SOP guidelines including company formations, vehicle dispersion and vehicle speed. They were expected to relay orders and reports from higher to lower echelons as accurately and rapidly as possible, and to prepare and relay reports from lower to higher echelons to provide a timely and accurate portrayal of enemy and friendly unit status. These lower echelon reports included those received directly from

SAFOR units in the CVCC condition, and those relayed by SAFOR operators in the Baseline condition. Participants were expected to engage enemy units as acquired with direct and indirect fires, unless otherwise ordered.

Exercises were halted by the Battle Master when the unit reached a terminal event, or time had expired. Participants dismounted the simulators after both training exercises for debriefs, and after the second and the final test exercise for "breaks." After the final break, participants returned to the classroom for a debrief by the Battle Master. The purpose of this debrief was to provide noncomparative feedback on the unit's performance during the test exercises and to obtain participants' comments and recommendations on their ability to meet the exercises' performance requirements, given their C<sup>2</sup> capabilities. Participants were released after completion of this debrief.

### Design

The design was a 2 x 3 (CVCC and Baseline conditions by Battalion, Company and Platoon echelons) between-subjects design. For the CVCC condition, participants completed all training and test exercises using the CVCC capabilities, previously described, supplemented by conventional C<sup>2</sup> equipment and procedures such as voice radio, map boards and acetate sheets. Baseline participants completed the same exercises using only conventional C<sup>2</sup> equipment, materials and procedures. For each test group, two participants were assigned to battalion and company echelons, and four participants to the platoon echelon. In general, measures for each test group were collapsed across test exercises to increase the power of analytic tests (see Analysis section).

Random assignment of test groups to conditions was prevented by the relatively imposing support requirement, 24 personnel per week, and the availability and readiness of MWTB and CVCC assets. Assignment of participants within each group was described in the Participants section, and group equivalence is considered at the start of the Results and Discussion section. All participants completed the same training and test exercises in the same order, and order effects were not controlled. A conceptual pilot test of the CVCC condition provided checks on the training, test materials and equipment developed for this evaluation. Minor adjustments were made to initialization files, training materials and logs based on observations made during this pilot.

The original evaluation schedule projected six days of data collection, four test exercises per day, for each condition: 24 test exercises per condition. Resources for the evaluation, including reliance on MWTB facility, equipment and personnel, precluded data collection beyond the days and weeks originally scheduled. Disruptions to the original schedule included equipment malfunctions, participant nonavailability, and overruns in the preceding training and evaluation of horizontal integration (Figure 3). Equipment problems generally resulted in temporary delays that permitted completion of all exercises during the final day. During one Baseline and one CVCC test week, all test exercises were completed after the noon lunch break; during two CVCC weeks, only the first three test exercises were successfully completed. Problems in participant assignment

(see Participants section) were adjusted per Contingency Rules. Overruns in prior training and evaluation efforts prevented data collection for one Baseline test week and two CVCC weeks. In summary, five weeks of test data, 20 exercises, were collected for Baseline units and four weeks of data, 14 exercises, for CVCC units.

### Data Reduction and Analysis

This evaluation used the data reduction procedures previously developed for CVCC evaluation efforts. Procedures for the reduction of CVCC's automated data and the manual transcription of voice recordings are described more fully by O'Brien et al. (1992a) and Leibrecht et al. (1994), respectively. Automated data from Datalogger magnetic tapes were extracted by DCA utilities based on the operational definitions developed for CVCC evaluations (O'Brien et al., 1992b; Leibrecht et al., 1994). Data packets were identified, selected and aggregated to produce the specified measures and preliminary output. Descriptive summaries and graphs of this output were visually examined for outliers, appropriately embedded flags, and values consistent with operational expectations and earlier CVCC efforts. Final DCA output files were prepared in a format compatible for import into SPSS/PC+.

Manual transcriptions of all voice communications from both conditions were prepared by support personnel using MWTB exercise playback equipment. Replay of the DataLogger tapes provided playback of the voice communications from each exercise over a SINGARS radio and visual recreation of the exercise events as seen from the PVD's bird's-eye perspective. Support personnel initially prepared a time-stamped, verbatim transcript for each combat net and then reduced and tabulated the communications on manual data reduction forms. These forms contained step-by-step instructions for tabulating specified voice-based measures such as number of messages transmitted, report accuracy and transmission time. Based on these tabulations, voice-reduction files were prepared in a format compatible for import into SPSS/PC+.

All analyses were performed using SPSS/PC+ routines (SPSS Inc., 1988). Primary parametric analyses used the Multivariate Analysis of Variance (MANOVA) program with its default adjustments for unique sums of squares and unequal sample sizes. These analyses were based on the 2 x 3 condition by echelon between-subjects design, previously described. The Echelon factor was excluded for selected measures that addressed echelon specific performance, such as platoon dispersion, or overall battalion performance, such as time to complete the exercise.

In general, measures for each test group were collapsed across test exercises to increase the power of analytic tests. Despite differences between test exercises, performance requirements across exercises were regraded as commensurate for most measures such as time to prepare and transmit orders and reports, accuracy and number of reports, speed and accuracy of direct and indirect fires, and mission completion. Performance requirements for selected measures such as distance travelled and exposure to the enemy, however, varied substantially between exercises. Such measures were identified and analyzed during an initial set of analyses that were based on a mixed-

factorial design. This design combined the between-subject factors of Condition and Echelon with repeated measures on an Exercise factor, with a maximum of four levels.

Main effects were tested with MANOVA simple tests and all interactions were tested using MANOVA simple-effects tests that maintained the overall model and used separate error terms at each level of the variable tested. Nonparametric analyses were used when parametric assumptions were not met (Siegel, 1965). An alpha level of .05 was used for all statistical tests and statements of "significant" findings.

## Results and Discussion

### Group Equivalence

Group equivalence tests between conditions, CVCC and Baseline, were based on participants' responses to the biographical questionnaire, Appendix F. Mean values on key biographical variables are provided in Appendix G by condition. With respect to participant officers who served as unit commanders and tank commanders, a series of analysis of variance (ANOVA) tests disclosed no significant differences between conditions. For NCO/enlisted participants, who served as crew members, similar ANOVA tests disclosed that those in the Baseline condition had significantly more time in active duty and as platoon sergeant and tank commander. Given the evaluation's focus and position assignments, differences favoring the Baseline should not account for findings of superior performance by CVCC participants on subsequent dependent measures.

### Maneuver BOS

Move on the surface. CVCC-equipped participants demonstrated significantly improved performance over Baseline participants on a number of important measures tested under the move on the surface function of the Maneuver BOS. Mean values for move on the surface measures are provided in Table 7 and source tables in Appendix H.

The first measure considered under move on the surface was the exposure of the test participants' simulators to the opposing force (OPFOR) vehicles. Exposure was determined by Data Collection and Analysis (DCA) routines that calculated the average number of live OPFOR vehicles with intervisibility to each of the manned participants' simulators based on 10-second samples taken from the MWTB's Ethernet network during each exercise. As indicated in Figure 9, overall mean exposure values to OPFOR vehicles were lower for the CVCC condition than the Baseline on each of the four test exercises. This pattern of reduced exposure, however, was not significant ( $F 1, 261 = 1.65, p = .20$ ).

Echelon differences on exposure were significant ( $F 2, 261 = 7.29, p = .00$ ) and reflected the higher exposure experienced by battalion-level participants (see Table 7). This difference was not due to condition, the Condition by Echelon interactions were not significant and the CVCC and Baseline battalion echelons had comparable mean values

Table 7

## Mean Performance for Move on the Surface Measures, by Condition

Measures	CVCC	Baseline
Exposure to opposing force (OPFOR) (number of enemy vehicles)	5.89 (6.80) $\underline{n}=107$	7.31 (8.08) $\underline{n}=160$
Range to OPFOR at displacement (meters)	6465.67 (3648.15) $\underline{n}=3$	7079.57 (3101.31) $\underline{n}=7$
Number of platoon vehicles with nearest vehicle <100 m	.80 (.59) $\underline{n}=14$	1.28 (.59) $\underline{n}=20$
Number of platoon vehicles with nearest vehicle >100 m & < 200 m	2.04 (.74) $\underline{n}=14$	2.14 (.60) $\underline{n}=20$
Number of platoon vehicles with nearest vehicle > 200 m	1.15 (.73) $\underline{n}=14$	.58 (.49) $\underline{n}=20$
Number of exercises completed within time	1.25 (.96) $\underline{n}=4$	1.00 (1.22) $\underline{n}=5$
Time to complete exercise (minutes)	25.78 (3.10) $\underline{n}=14$	26.54 (4.43) $\underline{n}=20$
Distance from scripted end point of exercise (meters)	1031.99 (524.56) $\underline{n}=14$	1842.42 (398.63) $\underline{n}=20$

Note. Standard deviations are in parentheses.

on each exercise. Although higher echelon commanders are generally not as exposed to the enemy as the members of their unit, this finding is consistent with the differential responsibilities of the participant commanders targeted by this evaluation. As monitors and communicators for the battalion, the battalion commander's and S3's area of interest included all the companies within the battalion. As a flank element, B Company was primarily concerned with only a portion of this battalion area. When the battalion echelon was excluded from the exposure analysis, platoon participants had significantly higher exposure levels than participants at the company level ( $F 1, 199 = 6.03, p = .02$ ). This finding was expected and partially confirmed that the 1st Platoon, B Company operated as the point element for the company.

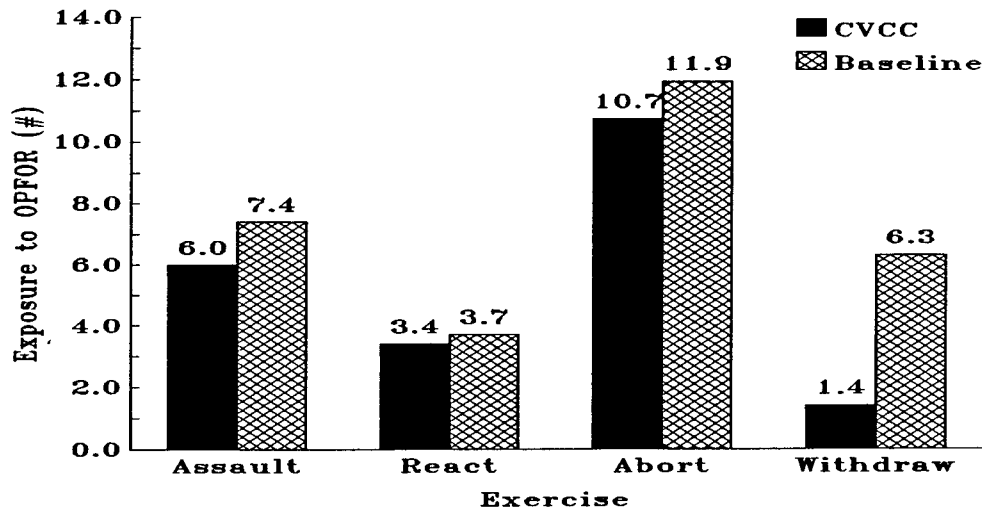

Figure 9. Mean exposure to opposing force (OPFOR), by exercise and condition.

Exposure differences between the four test exercises were to be expected as the first two exercises were hasty attacks on the battalion's right flank, the third an aborted attack, and the final exercise a defensive withdrawal under pressure. During the third exercise, for example, the BLUFOR battalion faced overwhelming enemy opposition and was forced to abort its attack. Overall exposure differences between exercises were significant ( $F_{3, 150} = 13.32, p = .00$ ). A simple-effects tests of Condition within Exercise disclosed that during the fourth exercise, a withdrawal, CVCC participants experienced significantly less exposure than the Baseline condition ( $F_{1, 53} = 3.97, p = .05$ ).

The second measure tested under the move on the surface function was the manned platoon's range to the OPFOR at displacement. This range was based on distance between the center-of-mass of the manned platoon and that of the nearest OPFOR company at the time the platoon displaced from its initial location during the fourth exercise. The conditional difference on this measure was not significant but in the expected direction. The OPFOR was 57 meters closer to the CVCC platoon than the Baseline platoon at the time of displacement, consistent with the FRAGO directive to delay displacement.

The next three measures under the move on the surface function addressed vehicle dispersion within the manned platoon. Dispersion was based on DCA routines that calculated the average number of vehicles within the manned platoons that met or exceeded prespecified intervehicular distances, based on 10-second network samples. CVCC platoons maintained significantly greater distances between vehicles (see Figure 10) while executing the test exercises' relatively impromptu FRAGO and movement requirements. More specifically, CVCC platoons had significantly fewer vehicles within 100 meters of other platoon members ( $F_{1, 32} = 5.36, p = .03$ ) and significantly more vehicles that maintained intervehicular distances greater than 200 meters ( $F_{1, 32} = 7.47, p = .01$ ).

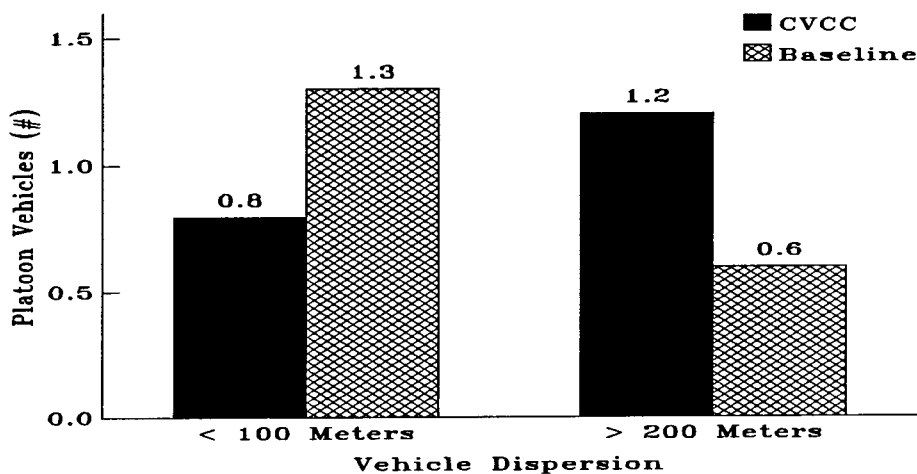

Figure 10. Mean number of platoon vehicles within 100 meters of each other and beyond 200 meters, by condition.

The last three measures under move on the surface addressed the unit's ability to complete the exercises and missions assigned. The percentage of exercises completed measure was determined by dividing the number of exercises attempted by the number of exercises in which units reached the scripted end-point before time had expired (see Appendix A). Exercise time commenced with the exercise start cue (T+00:00) and ended when the unit reached the scripted end-point, or time had expired. The five minutes provided for orientation prior to each exercise was excluded from exercise time. Distance from the scripted end-point of each exercise was based on company and platoon participants' vehicle locations relative to end-points not reached, equated to zero distance for end-points reached.

CVCC units completed 5 of their 14 exercises, 35%, and Baseline units completed 5 of 20 exercises, 25%, a difference in the expected direction but not significant. Similarly, mean exercise times were 25.7 minutes for CVCC and 26.5 minutes for the Baseline, negligibly faster for the CVCC condition. Distance from scripted end-point successfully distinguished performance between the two conditions. As indicated in Figure 11, the CVCC company and platoon vehicles finished consistently closer to each of the end-points specified by the test exercises. Since the manned platoon operated as point element for the company it was typically the first echelon to reach the end-point. Distances from the end-point based on averaged locations of the manned platoon vehicles were significant ( $F_{1, 7} = 7.14, p = .03$ ). When this measure was extended to include the averaged locations of the manned company vehicles, CVCC units still finished significantly closer to the end-point ( $F_{1, 7} = 6.99, p = .03$ ).

In discussion, results for a number of key measures related to the move on the surface function under the Maneuver BOS revealed significantly improved performance by CVCC-equipped participants. The CVCC condition performed better, not always significantly, on all measures tested for this function. Significant findings included limited support for reduced exposure, more dispersed platoon maneuver, and more successful mission completion based on distance from scripted end-points.

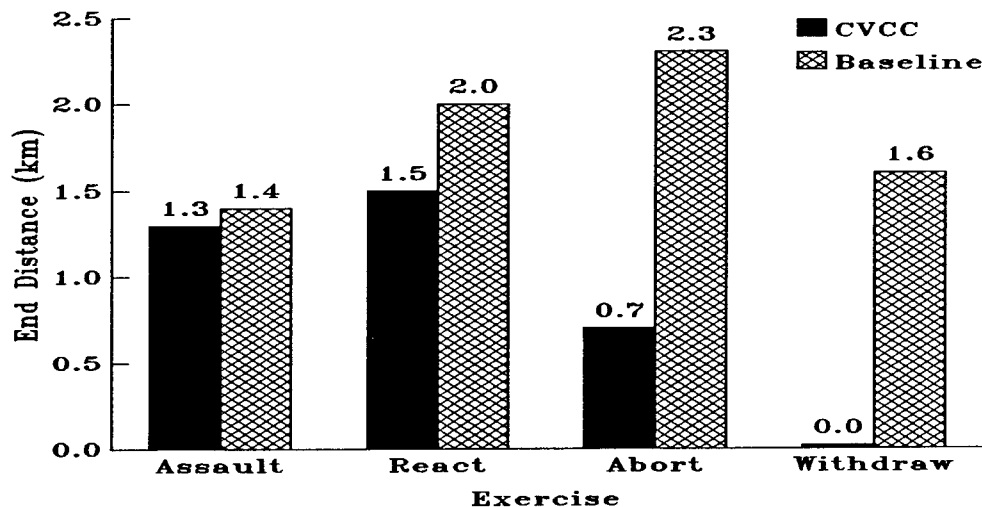

Figure 11. Mean distance from scripted end point of each exercise, by condition.

While reduced exposure to OPFOR is a critical concern, digital C<sup>2</sup> expectations frequently presume a near real-time depiction of enemy type, size and location relative to own and friendly units (Clark, 1993; Funk, 1993). To achieve this capability, robust digital links with integrated reconnaissance and surveillance systems are required. Such a capability was not simulated in this evaluation and it is one of the formidable challenges in meeting the expectations for digital force integration (U.S. Army Armor Center, 1994). The significantly reduced exposure of CVCC participants in the defensive exercise, however, suggests that integrated tactical displays, such as the CCD, may help units avoid exposure when required. As Baseline participants attempted withdrawal along prespecified routes, they were overtaken by the assaulting OPFOR. In contrast, CVCC platoons were able to avoid such exposure, in part, because CVCC's transmittal and display of route information expedited the unit's orderly withdrawal from the attacking force.

Method limitations leveled performance across conditions for measures on number of exercises completed and exercise time. The time provided for each exercise was not sufficient to allow completion by most units, regardless of condition, and limited the opportunity for obtaining differences on both of these measures. Time constraints were imposed to force high-tempo operations and maximize repetition of measures. In future efforts, the allotment of more time per exercise might result in more discriminating performance. Similarly, the five minutes given for orientation to exercise locations may undermine the potential of CVCC units, relative to conventional, to expedite mission execution. CVCC commanders should be able to execute missions sooner as the CCD provides precise own location data and graphically depicts own and unit locations relative to terrain, operational overlays, and designated routes.

The strongest support for CVCC's ability to improve move on the surface performance was found in vehicle dispersion and distance from end-point measures. The ability of CVCC platoons to maintain greater dispersion while executing the exercises' challenging and unrehearsed FRAGOs was clearly demonstrated. More stringent

exercise or operational requirements such as low visibility conditions might result in more discriminating differences between test conditions.

Findings on platoon dispersion bolstered the expectation that digital C<sup>2</sup> systems will increase the survivability of maneuver units by allowing them to navigate and maneuver more independently (Clark, 1993; U.S. Department of the Army, 1994). This expectation is based primarily on the commander's ability to monitor continuously the locations of friendly vehicles and units on his tactical display. When commanders can maintain an awareness of own and other friendly vehicle locations, they may disperse their unit more readily to increase its survivability and to provide the freedom of maneuver required for positional advantage.

Finally, distance from scripted end-point findings demonstrated that CVCC participants were significantly better at meeting the demanding maneuver requirements imposed by the exercises' FRAGOs. These FRAGOs forced B Company to embark on prespecified axes or routes that triggered contact and response to enemy forces, followed by the company's return to and continued support of the battalion's basic MTC mission. In ARI's earlier C<sup>2</sup> system evaluations, digitally equipped units excelled on similar mission completion measures at platoon, company and horizontally-linked battalion levels (Du Bois & Smith, 1991; Leibrecht et al., 1992, 1994). For the current evaluation, performance on this measure provided the best global indicator of the CVCC unit's ability to complete the exercises and missions assigned more successfully.

Navigate. CVCC-equipped participants demonstrated significantly improved performance over Baseline participants on nearly every measure tested under the navigate function of the Maneuver BOS. Mean values for selected navigation measures are provided in Table 8 and source tables in Appendix H.

The first measure under navigate was the percentage of time spent at a halt. This measure was based on the proportion of time each manned simulator's velocity was zero during an exercise, based on 10-second samplings from the MWTB's Ethernet network. Overall percentage of time at a halt across exercises was 57% for the CVCC condition and 62% for the Baseline, a difference in the direction expected but not significant. The effect of Echelon was significant ( $F$  2, 263 = 10.13,  $p$  = .00) and a simple test of main effect revealed that battalion-level participants were halted significantly more often than their company ( $F$  1, 266 = 10.54,  $p$  = .00) or platoon participants ( $F$  1, 266 = 14.16,  $p$  = .00).

As the FRAGOs were directed at B Company, more extended halts by battalion-level participants were to be expected. The battalion commander and S3 served primarily as controllers and communicators with respect to B Company as well as the battalion's other semiautomated companies and assets. When battalion commander and S3 data were excluded, the halt time percentages for B Company participants were 53% for CVCC and 61% for the Baseline (see Figure 12). This difference was significant and indicated that B Company participants in the CVCC condition spent significantly less time halted than their Baseline counterparts ( $F$  1, 200 = 13.25,  $p$  = .00). Simple effects

Table 8

## Mean Performance for Selected Navigate Measures, by Echelon and Condition

Measures	Battalion		Company		Platoon	
	CVCC	Baseline	CVCC	Baseline	CVCC	Baseline
Percentage of time at halt	70.02% (19.03) $\underline{n}=25$	65.07% (16.80) $\underline{n}=40$	51.99% (15.72) $\underline{n}=28$	62.08% (12.99) $\underline{n}=40$	54.05% (19.40) $\underline{n}=56$	60.53% (12.09) $\underline{n}=80$
Moving speed (km/hr)	31.39 (10.83) $\underline{n}=25$	33.04 (11.98) $\underline{n}=40$	28.69 (10.52) $\underline{n}=28$	34.81 (10.09) $\underline{n}=40$	27.17 (10.47) $\underline{n}=53$	34.54 (9.11) $\underline{n}=80$
Percentage of time speed > 40 km/hr	68.25% (22.41) $\underline{n}=25$	64.49% (26.60) $\underline{n}=40$	75.04% (21.17) $\underline{n}=28$	59.97% (22.16) $\underline{n}=40$	78.15% (20.87) $\underline{n}=53$	61.63% (22.67) $\underline{n}=80$
Distance travelled (meters)	3755.92 (2111.64) $\underline{n}=25$	5035.29 (2801.93) $\underline{n}=40$	5725.58 (2623.24) $\underline{n}=28$	5566.55 (2483.16) $\underline{n}=40$	5346.90 (2994.88) $\underline{n}=56$	5935.59 (2674.72) $\underline{n}=80$
Fuel used (gallons)	6.54 (3.52) $\underline{n}=25$	8.41 (3.79) $\underline{n}=40$	7.84 (2.92) $\underline{n}=28$	8.60 (3.42) $\underline{n}=40$	7.39 (3.51) $\underline{n}=56$	8.90 (3.67) $\underline{n}=80$

Note. Standard deviations are in parentheses.

tests of Condition within Echelon disclosed that both Baseline company and platoon participants spent significantly more time halted than their CVCC counterparts, respectively ( $F$  1, 263 = 6.77,  $p$  = .01) and ( $F$  2, 263 = 5.58,  $p$  = .02).

Mean velocity while moving was the average speed of each manned simulator during the exercises. Percentage of time that vehicle velocity was greater than 40 km per hour was the proportion of movement time each simulator exceeded that speed. Both of these measures excluded zero velocity values from samples extracted every 10-seconds from the MWTB's Ethernet network. While the Baseline simulators had a significantly faster average movement speed ( $F$  1, 260 = 13.73,  $p$  = .00), the CVCC simulators had a significantly greater proportion of time their speed exceeded 40 km per hour ( $F$  1, 260 = 15.42,  $p$  = .00), see Figure 12. Neither Echelon or Condition by Echelon effects were significant on either of these two measures.

Mean distance travelled was the cumulative distance, in meters, driven by the manned simulators during the exercises and was based on odometer readings. Simulators in the CVCC condition averaged 5,079 meters per exercise compared with 5,618 meters for the Baseline, a difference in the direction expected but not significant. Echelon differences on distance travelled were significant ( $F$  2, 263 = 5.06,  $p$  = .01) and simple tests of this main effect showed that battalion-echelon participants travelled

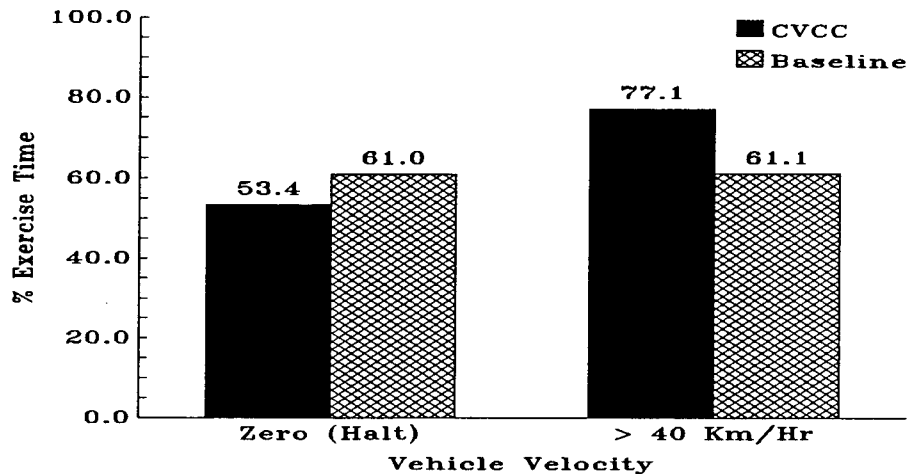

Figure 12. Mean percent of time that manned company and platoon vehicles were not moving (vs. moving) and moving faster than 40 km/hr (vs. slower), by condition.

significantly shorter distances than either company-level ( $F_{1, 266} = 5.42, p = .02$ ) or platoon participants ( $F_{1, 266} = 8.00, p = .01$ ). Again, the fact that members of B Company travelled more than battalion-level personnel was not surprising given their different exercise roles. A between condition comparison of only battalion echelon participants indicated that the Baseline battalion commander and S3 travelled significantly farther than their CVCC counterparts ( $F_{1, 63} = 3.84, p = .05$ ).

Mean fuel used was simply the total amount of simulated fuel, in gallons, consumed by each simulator during the exercises. For the CVCC condition, each manned simulator averaged 7.3 gallons per exercise compared with the Baseline average of 8.7 gallons. This difference established that the CVCC condition used significantly less fuel than the Baseline condition ( $F_{1, 263} = 8.86, p = .00$ ).

Mean time out of sector and beyond axis measures were designed to quantify the time any manned simulator spent beyond the sectors or axes assigned to B Company. Similarly, time misoriented was the elapsed time any simulator traveled in an identifiably wrong direction. Boundary violations and misorientations were based on judgements by the PVD operators with times marked and recorded by PVD event flags, Appendix E. Three instances of misorientation were recorded for Baseline simulators with a mean time of 1.02 minutes; no CVCC misorientations were recorded. Two instances of Baseline simulators out of sector were recorded and one instance of a CVCC simulator out of sector. Times were not available for these out of sector events. No analyses of the data for these two measures were attempted.

In discussion, results on nearly every navigate measure under the Maneuver BOS revealed significantly improved performance by CVCC-equipped units. In general, CVCC participants at company and platoon levels spent significantly less time halted than the Baseline units and executed the demanding navigational routes from the FRAGOs significantly faster. Within the battalion command group which primarily monitored mission execution, CVCC commanders travelled significantly shorter distances

than their Baseline counterparts. Across all echelons, CVCC equipped commanders consumed significantly less fuel and yet completed significantly more of the FRAGOs' mission-based navigational requirements.

Time at a halt data confirmed many of the navigational advantages anticipated for digitally equipped battalion level forces. In ARI's earlier C<sup>2</sup> system evaluations, digitally equipped units at platoon and company levels also spent less time halted (Du Bois & Smith, 1991; Leibrecht et al., 1992). In the current evaluation, time at a halt provided an excellent example of CVCC's differential advantages across a vertically integrated force. In general, halt time frequently extends the time required to execute combat operations for reasons ranging from dismounts for orders dissemination and coordination with adjacent units to disorientation and "deadlined" equipment. A coveted goal is to minimize "down" time or time spent "standing around." That goal was central to the high-tempo FRAGOs dictating the mission for each exercise. B Company's significant reduction in halt time advanced the expectation that integrated tactical displays may help combat units sustain the accelerated pace anticipated on future battlefields.

As complement to the company and platoon halt data, CVCC's battalion command group travelled significantly less distance than their Baseline counterparts. By design, the FRAGOs were directed at B Company and the battalion commander and his S3 primarily monitored and controlled B Company's execution. An interesting interpretation is that the CVCC battalion command group was able to monitor the execution of B Company from afar.

Frequently, a conventionally equipped battalion commander can not directly monitor simultaneously his entire battalion due to the area covered, the concealment used and the locations obstructed by terrain. If Baseline battalion-level commanders elected to directly monitor mission execution, they were required to move with B Company. Such movement may account for the findings that, relative to their CVCC counterparts, Baseline battalion-level commanders were more exposed to the enemy and travelled significantly greater distances. When a battalion is vertically integrated, the battalion commander can directly monitor the movement and formation of the battalion down to individual vehicles. The CVCC commanders' CCDs continuously updated the location of every battalion vehicle on their tactical display, relative to the FRAGO control measures governing mission execution.

When moving, CVCC units spent a significantly greater proportion of their time travelling at faster speeds. Although speed is meaningless in the wrong direction, the CVCC units finished significantly closer to the specified end-points of the exercises. The CCD's display of vehicle and unit location relative to control measures and its automatic update of navigation waypoints to the drivers' display, presumably, expedited CVCC navigation. Again, the accelerated pace of the CVCC units bolstered the expectation that automated C<sup>2</sup> systems may enable vertically integrated units to maintain the high-tempo operations mandated by future doctrine.

While CVCC units travelled less distance than the Baseline, despite finishing closer to exercise end points, the difference was significant only at the battalion echelon. In general, it was expected that units equipped with integrated digital systems would navigate more efficiently and thereby reduce the distance travelled relative to conventional units. Although "distance" is magnified by navigational error, it is not a very direct indicator of mission requirements or success. This is particularly true when comparing missions of varying nature such as those used in the exercises tested. For some of the exercises, such as Withdraw, greater distance was required to fully complete the withdrawal. Optimal distance for the Abort exercise, on the other hand, was more indefinite and judgmental.

A more direct measure of navigational efficiency is fuel consumed, particularly when a unit completes more of its mission while expending less of its resources. The CVCC units used significantly less fuel while reducing their exposure, maintaining greater dispersion, spending less time at a halt, travelling at faster speed, and finishing closer to the exercises' end points. The M1 tank is not fuel efficient, approximately two miles per gallon, and exceeds the speed of its logistic trains and refuel assets. The evidenced reduction in fuel consumption by CVCC units confirmed (see Du Bois & Smith, 1991; Leibrecht et al., 1992) the expectation that its navigational features will help maintain the force tempo required on the future battlefield.

Instances of misorientation and vehicles out of sector, during the exercises, were too infrequent to support a finding of difference between conditions. CVCC manned simulators had fewer instances of such errors but analysis was not attempted. Method adjustments to better substantiate expected differences in orientation might include automated routines for detecting misorientation and boundary violations, observational judgements by assigned subject matter experts, and conduct of the exercises under low visibility conditions.

Process direct fire targets. CVCC and Baseline units demonstrated comparable performance on most measures tested under the process direct fire targets function of the Maneuver BOS. CVCC participants had significantly faster minimal lase times to different targets and significantly greater maximum lase range to targets, relative to Baseline participants. Mean values for selected process direct fire targets measures are provided in Table 9 and source tables in Appendix H. For all lase-based measures tested, Baseline condition lases originated only from the Gunner's Primary Sight (GPS) but CVCC lases originated from either the GPS or the Commander's Independent Thermal Viewer (CITV). Lases beyond 3,500 meters were excluded due to visual range restrictions in the MWTB.

In preface, the MWTB and its distributed simulation environment was not designed as a high-fidelity gunnery simulator. Testbed limitations affected gunnery performance and the data reported in this and the following subsection, engage direct fire targets. Such limitations include low-fidelity computer-image generators (CIGs), a restricted viewing area from the commander's vision block, and inadequate thermal imagery. Data obtained on direct fire processing and engagement, therefore, provided a

Table 9

## Mean Performance for Selected Process Direct Fire Targets Measures, by Echelon and Condition

Measures	Battalion		Company		Platoon	
	CVCC	Baseline	CVCC	Baseline	CVCC	Baseline
Time to acquire targets (minutes)	2.36 (1.75) $\underline{n}=18$	2.53 (1.47) $\underline{n}=22$	2.19 (1.12) $\underline{n}=24$	2.77 (1.79) $\underline{n}=28$	2.48 (1.16) $\underline{n}=48$	2.46 (1.31) $\underline{n}=62$
Time between lases to different targets (minutes)	.75 (.52) $\underline{n}=17$	.98 (1.14) $\underline{n}=22$	.81 (.48) $\underline{n}=25$	1.02 (.95) $\underline{n}=21$	.70 (.48) $\underline{n}=48$	.74 (.71) $\underline{n}=61$
Time from first lase to first fire (minutes)	.24 (.15) $\underline{n}=10$	.19 (.14) $\underline{n}=15$	.36 (.35) $\underline{n}=19$	.51 (.99) $\underline{n}=17$	.43 (.48) $\underline{n}=36$	.26 (.31) $\underline{n}=53$
Maximum lase range (meters)	2275.50 (1112.15) $\underline{n}=20$	2383.54 (901.67) $\underline{n}=28$	3106.60 (390.04) $\underline{n}=25$	2108.10 (1059.12) $\underline{n}=31$	2865.02 (615.06) $\underline{n}=45$	2521.77 (775.49) $\underline{n}=69$

Note. Standard deviations are in parentheses.

basis for conditional comparisons within this evaluation and related MWTB efforts but should not be considered representative of actual gunnery performance.

Time to acquire targets was defined as the average elapsed time from first intervisibility between an OPFOR vehicle and a manned simulator to the time that simulator first lased the OPFOR vehicle. Intervisibility was based on DCA routines that required at least 6 consecutive seconds of initial intervisibility and excluded intervals greater than 7 minutes. Overall mean times to acquire targets across echelons were 2.38 minutes for CVCC participants and 2.55 minutes for Baseline participants. This difference was in the direction expected but not significant. Neither Echelon or Condition by Echelon effects were significant for this measure.

Time between lases to different targets was defined as the average elapsed time from a simulator's last lase on an OPFOR vehicle to its first lase on a different OPFOR vehicle. Durations longer than 5 minutes were excluded in an effort to restrict measurement to multiple-target conditions. Overall mean times between lases were .74 minutes for CVCC participants and .84 minutes for Baseline participants. This difference was in the direction expected but not significant. Neither Echelon or Condition by Echelon effects were significant for this measure. Minimum time between lases was also calculated for each manned simulator during each exercise. Minimum mean times between lases across echelons were 11.3 seconds for CVCC participants and 24.4 seconds for Baseline participants (see Figure 13). CVCC's 13-second faster lase to the next target was significant ( $F$  1, 188 = 10.03,  $p$  = .00). Neither Echelon or Condition by Echelon effects were significant for minimum time between target lases.

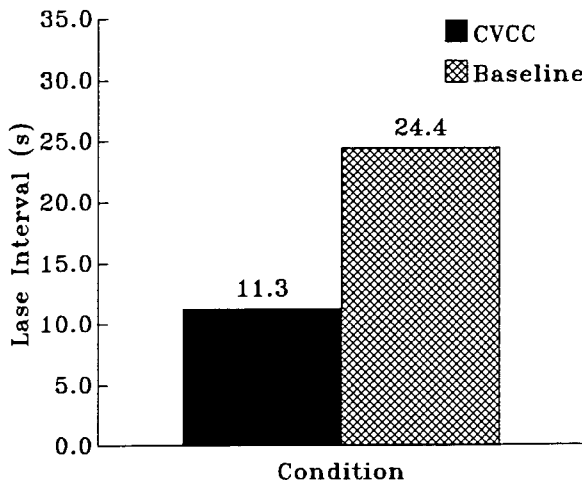

Figure 13. Mean minimum time between lases to different targets, by condition.

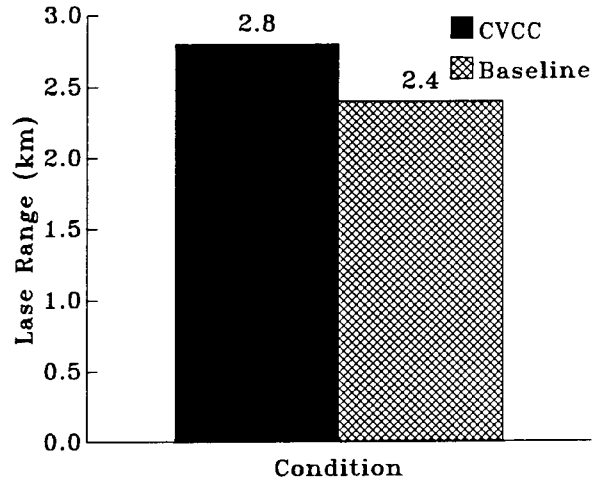

Figure 14. Mean maximum lase range to enemy targets, by condition.

Time from lase to first fire was the average elapsed time from when a manned simulator first lased on an OPFOR vehicle until that simulator first fired on the same OPFOR vehicle, and direct fires included hits and misses. Overall mean times from lase to first fire were .38 minutes for CVCC participants and .30 minutes for Baseline participants. This difference was neither in the direction expected or significant. Neither Echelon or Condition by Echelon effects were significant for this measure.

The maximum lase range was the greatest distance between a manned simulator and the enemy target lased by that simulator, based on DCA routines for identifying lases to enemy targets versus lases to points of interest or nontarget locations. Average maximum lase ranges across echelons were 2,801 meters for CVCC participants and 2,391 meters for Baseline participants (see Figure 14). This difference was in the direction expected and significant ( $F 1, 212 = 11.81, p = .00$ ). The effect for Echelon was significant ( $F 2, 212 = 3.28, p = .04$ ) and a simple test of main effect indicated that maximum lase range for battalion-level participants was significantly shorter than for platoon participants ( $F 1, 215 = 4.69, p = .03$ ). The Condition by Echelon effect was also significant for this measure and simple effects test disclosed significantly longer maximum lase ranges for CVCC company-level ( $F 1, 212 = 20.85, p = .00$ ) and platoon participants ( $F 1, 212 = 4.85, p = .03$ ), relative to their Baseline counterparts.

Number of fratricide hits by manned vehicles was based on the cumulative number of main gun hits by manned vehicles on any BLUFOR vehicles. Similarly, number of fratricide kills by manned vehicles was based on the cumulative number of direct fire kills by manned vehicles on any BLUFOR vehicles that resulted in destruction of the vehicle or its firepower system. The number of fratricide hits by CVCC participants were 7 compared to only 1 by Baseline participants. The CVCC hits resulted in 4 fratricide kills compared to zero Baseline kills. All CVCC hits and kills were caused by two participants during the same test week. Differences were neither in the direction expected or significant. No analysis of this data was attempted.

In discussion, CVCC units demonstrated significantly better performance on several key measures tested under the process direct fire targets function of the Maneuver BOS, despite their relatively comparable performance on other measures. CVCC participants had significantly faster minimal lase times to different targets and significantly greater maximum lase range to targets compared to Baseline participants.

Data on time to acquire targets disclosed no significant differences between conditions. Nevertheless, on the average, CVCC battalion level commanders acquired targets 10 seconds faster than their Baseline counterparts and CVCC company commanders acquired targets almost 35 seconds faster than their Baseline counterparts. In an operational context, such differences might well be meaningful. Future efforts might consider revisions in the DCA acquisition routines to develop a more discriminating measure. In addition, ongoing upgrades in CIG fidelity in the MWTB are expected to impact acquisition times and should prompt a review of DCA acquisition measures. With the proposed introduction of digital C<sup>2</sup> systems, a concern frequently raised is that commanders may "fixate" on their tactical display and lose track of the surrounding battlefield and enemy threat. The acquisition times of the CVCC commanders and crews countered this concern. At battalion and company levels, acquisition times clearly indicated CVCC commanders were as vigilant as their Baseline counterparts.

CVCC-equipped units were significantly faster at processing multiple targets, as indicated by a comparison of minimum time between lases to different targets. The earlier description of the CITV (see CVCC System Development under the General Research Requirement section) noted that it supports simultaneous hunter-killer activities by the commander and gunner. When confronted by multiple targets, a CVCC commander can independently acquire and lase additional targets from the CITV while the gunner "services" the current target. Results on lases to sequential targets supported the prominent expectation that CITV-equipped units will acquire and process multiple targets faster on the future battlefield (Leibrecht et al., 1992, 1994; Quinkert, 1990).

As expected and indicated by a comparison of maximum lase range data, CVCC units acquired enemy targets at significantly greater distances than baseline units. The provision of an independent thermal viewer to the tank commander has repeatedly proven (Leibrecht et al., 1992, 1994) an effective system for extending the acquisition capabilities of an armor unit. The full potential of extended lase range, however, can only be realized in a vertically integrated unit.

For units with vertically-integrated digital C<sup>2</sup> systems, extended lase range provides more effective and varied options for target processing. With the CITV's far-target designation capability that automatically inputs grid locations into CCD-based enemy reports, commanders can rapidly and accurately request indirect fires to destroy or suppress the enemy or prevent disclosure of own location. Within the unit, and particularly in a defensive setting, far-target designate coupled with transmission of such reports provides a basis for the automated fire distribution and target designation capabilities anticipated in a digitally integrated force (Clark, 1993).

The extended lase range of CVCC units combined with the visual fidelity limitations of the MWTB simulation, may account for the fact that Baseline units exhibited somewhat faster lase-to-fire times than CVCC units. While lase-to-fire times were not significantly different, CVCC units apparently acquired targets at ranges that prevented visual confirmation of the target as an enemy vehicle. A comparison of acquisition ranges with hit and kill ranges, in the engage direct fire targets subsection, suggests CVCC commanders deliberately delayed firing, most likely to avoid fratricide.

Nevertheless, CVCC participants tended to engage and kill friendly vehicles more frequently than the Baseline condition. Fratricide events were too limited to support analytic comparisons and appeared nonrepresentative of the CVCC condition; all CVCC instances occurred during the same test week and were caused by 2 of the 31 CVCC crews tested during the evaluation. The potential for fratricide, however, can not be ignored. On the training side, operators of new and complex equipment, such as digital C<sup>2</sup> systems, may need additional training and familiarization time to avoid interference with other duties and responsibilities. On the design side, an integrated digital system should automatically compare lase and far-target inputs against known friendly vehicle locations and then issue immediate alerts.

Engage direct fire targets. CVCC and Baseline participants demonstrated comparable performance on most measures tested under the engage direct fire targets function of the Maneuver BOS. The exceptions were that CVCC company and platoon participants evidenced significantly greater hit and kill range than their Baseline counterparts. And across all echelons, CVCC participants fired significantly more main gun rounds per vehicle, relative to Baseline participants. Overall mean values for selected measures under engage direct fire targets are provided in Tables 10 and 11 with source tables in Appendix H. For all measures under this function, enemy and friendly "kills" included destroyed vehicles, referred to as catastrophic kills, and disabled firepower systems, referred to as firepower kills. Kills were determined by the manned vehicle's host computer or the SAFOR computer.

The losses/kills ratio was determined by dividing the total number of manned and semiautomated BLUFOR losses due to enemy kills, by the total number of OPFOR losses due to BLUFOR kills. Lower ratios indicate better performance by the BLUFOR battalion. Overall mean losses/kills ratios were .48 for the CVCC battalions and .73 for the Baseline battalions. This difference was in the direction expected but not significant.

Mean target hit range was based on the average distance between a firing manned simulator and the OPFOR vehicle hit by the round fired. Overall, mean target hit ranges were 2,379 meters for CVCC participants and 2,015 meters for Baseline participants (see Figure 15 for mean ranges by echelon). This difference was significant ( $F_{1, 102} = 3.84, p = .05$ ) and indicated CVCC participants hit enemy targets at extended ranges relative to the Baseline. Neither Echelon or Condition by Echelon effects were significant for this measure.

Table 10

## Mean Performance for Selected Engage Direct Fire Targets Measures, by Condition

Measures	CVCC	Baseline
Losses/kills ratio	.48 (.49) $\underline{n}=14$	.73 (.81) $\underline{n}=19$
Percentage of OPFOR vehicles killed by manned vehicles	34.11 (32.00) $\underline{n}=14$	35.94 (35.17) $\underline{n}=18$
Number of manned vehicles sustaining a killing hit	1.71 (1.94) $\underline{n}=14$	1.40 (1.27) $\underline{n}=20$

Note. Standard deviations are in parentheses.

Mean target kill range was based on the average distance between a manned simulator as it fired and the OPFOR vehicle killed by the round fired. Overall mean target kill ranges were 2,304 meters for CVCC participants and 1,999 meters for Baseline participants. This difference was in the direction expected but not significant. Neither Echelon or Condition by Echelon effects were significant for this measure. Given the disparate roles of the battalion command group versus B Company and that the FRAGOs were directed at B Company missions, a separate analysis on mean target kill range was performed that excluded the battalion echelon. Results from that test indicated that CVCC company and platoon participants killed enemy targets at significantly greater ranges than their Baseline counterparts, ( $F$  1, 72 = 5.43,  $p$  = .03).

The percentage of OPFOR vehicles killed by the manned simulators was the proportion of OPFOR vehicles killed during each exercise by main gun rounds from the manned simulators. Semiautomated friendly forces and indirect fires accounted for the remainder of OPFOR kills. Overall mean percentages of OPFOR kills were 34% for CVCC participants and 36% for Baseline participants. This difference was neither in the direction expected or significant. Neither Echelon or Condition by Echelon effects were significant for this measure.

The following three ratios reflected the accuracy and effectiveness of rounds fired by the manned simulators, and larger ratios indicated better performance. The hits/round ratio was based on the proportion of rounds fired by each manned simulator that resulted in hits on OPFOR vehicles. The kills/round ratio was the proportion of rounds fired by each manned simulator that resulted in kills on OPFOR vehicles. Finally, the kills/hit ratio was the proportion of hits on enemy vehicles by each manned simulator that resulted in kills.

Overall mean hits/round ratios across echelons were .23 for CVCC participants and .26 for Baseline participants. This difference was neither in the direction expected

Table 11

## Mean Performance for Selected Engage Direct Fire Target Measures, by Echelon and Condition

Measures	Battalion		Company		Platoon	
	CVCC	Baseline	CVCC	Baseline	CVCC	Baseline
Target hit range (meters)	2490.32 (444.30) $\underline{n}=5$	2372.72 (725.17) $\underline{n}=11$	2435.20 (567.77) $\underline{n}=14$	2133.18 (671.95) $\underline{n}=11$	2327.04 (476.94) $\underline{n}=26$	1887.49 (662.27) $\underline{n}=41$
Target kill range (meters)	1921.80 (927.58) $\underline{n}=3$	2488.54 (498.61) $\underline{n}=9$	2341.47 (648.56) $\underline{n}=12$	2033.86 (831.95) $\underline{n}=8$	2331.33 (597.04) $\underline{n}=25$	1848.07 (619.77) $\underline{n}=31$
Hits/round ratio, manned vehicles	.17 (.29) $\underline{n}=12$	.30 (.30) $\underline{n}=18$	.25 (.23) $\underline{n}=20$	.22 (.29) $\underline{n}=21$	.24 (.24) $\underline{n}=40$	.26 (.26) $\underline{n}=55$
Kills/hit ratio, manned vehicles	.32 (.32) $\underline{n}=5$	.49 (.39) $\underline{n}=11$	.56 (.39) $\underline{n}=14$	.28 (.35) $\underline{n}=11$	.37 (.24) $\underline{n}=26$	.43 (.37) $\underline{n}=41$
Kills/round ratio, manned vehicles	.04 (.07) $\underline{n}=12$	.12 (.18) $\underline{n}=18$	.13 (.17) $\underline{n}=20$	.05 (.10) $\underline{n}=21$	.10 (.13) $\underline{n}=40$	.12 (.17) $\underline{n}=55$
Number of rounds fired, manned vehicles	2.48 (3.92) $\underline{n}=25$	2.70 (4.60) $\underline{n}=40$	6.89 (6.90) $\underline{n}=28$	3.13 (5.08) $\underline{n}=40$	8.34 (7.96) $\underline{n}=56$	6.68 (6.78) $\underline{n}=80$

Note. Standard deviations are in parentheses.

or significant. Overall mean kills/round ratios across echelons were .10 for both conditions. Neither Echelon or Condition by Echelon effects were significant for these two measures. Overall mean kills/hit ratios across echelons were .42 for both conditions. Although the Condition by Echelon interaction was significant ( $F_{2, 160} = 3.14, p = .05$ ), neither the main effects or simple effects test of this interaction were significant. Inspection of the means by echelon suggests the interaction was due to higher kills/hit ratios by the Baseline battalion-level and CVCC company-level participants.

The number of manned vehicles sustaining a killing hit was a count of participant simulators that experienced at least one killing hit, from friendly or enemy fire, during each exercise. Despite the "kill suppress" feature that overrode damaging or disabling direct and indirect fire effects to the manned simulators, kill events were recorded by the DCA's DataLogger. Across echelons, the mean number of simulators experiencing at least one kill per exercise was 1.7 for CVCC participants and 1.4 for Baseline participants. This difference was neither in the direction expected or significant.

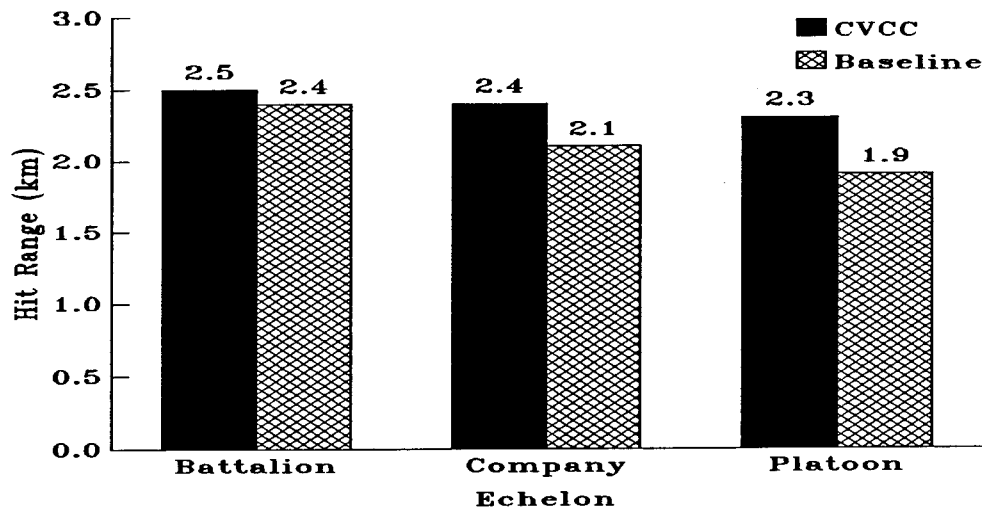

Figure 15. Mean target hit range per manned simulator, by echelon and condition.

The number of rounds fired by manned simulators was the total number of main gun rounds fired by each participant's simulator. Overall mean number of rounds fired across echelons was 6.62 for CVCC participants and 4.79 for Baseline participants (see Figure 16 for mean rounds fired by echelon). This difference was in the direction expected and significant ( $F$  1, 263 = 4.32,  $p$  = .04). The effect for Echelon was significant ( $F$  2, 263 = 13.10,  $p$  = .00) and a simple test of main effect indicated that platoon participants fired significantly more rounds than battalion-level participants ( $F$  1, 266 = 24.09,  $p$  = .00). The Condition by Echelon effect was also significant and a simple effects test disclosed that significantly more rounds were fired by CVCC company-level participants ( $F$  1, 263 = 5.80,  $p$  = .02), relative to their Baseline counterparts.

In discussion, CVCC units demonstrated significantly better performance on several important measures tested under the engage direct fire targets function of the Maneuver BOS. Relative to the Baseline, CVCC company and platoon participants acquired and killed enemy targets at significantly greater ranges. Across all echelons, CVCC participants fired significantly more main gun rounds than the Baseline condition.

Data on the losses/kills failed to provide a significant difference between the CVCC and Baseline conditions. While the overall mean values of .48 for the CVCC battalions and .73 for the Baseline battalions were in the direction expected and sizeable, the variation between exercises reduced the opportunity for confirming hypothesized differences.

Direct fire from the CVCC manned simulators hit enemy targets at significantly greater distances than that from the Baseline units. Extended hit range was consistent with the significantly greater lase range demonstrated by the CVCC participants and consistent with earlier CVCC/CITV findings (Leibrecht et al., 1992, 1994; Quinkert, 1990). Although the effect of Condition by Echelon was not significant with the current sample, Figure 15 depicts a reassuring pattern of comparative advantage in hit distances by echelons. The hit range advantage provided by CVCC increased at the lower

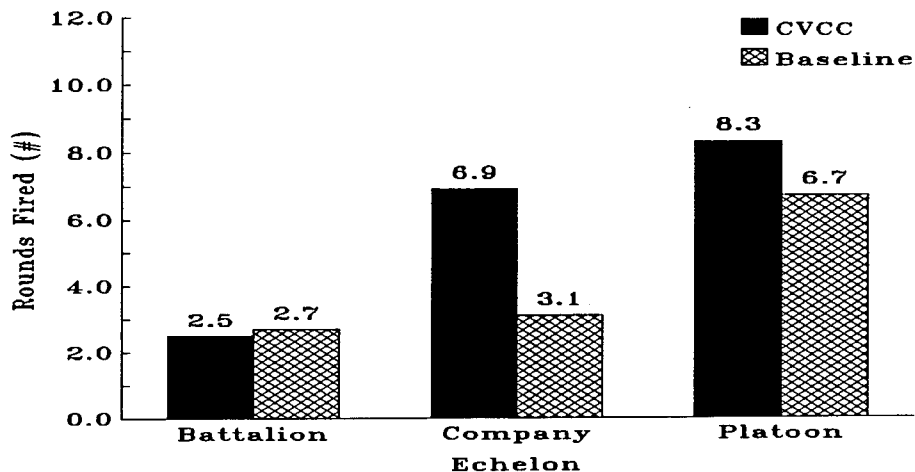

Figure 16. Mean number of main gun rounds fired per manned simulator, by echelon and condition.

echelons. Reassuring, in that the battalion's front-line fighters, its platoons, might derive the greatest benefit from CVCC's extended hit range.

The CVCC advantage in target hit range did not result in significantly greater kill ranges across all echelons. When the battalion command group was excluded from the analysis, given their unique role in the exercises, CVCC company and platoon participants did kill enemy targets at significantly greater ranges than their Baseline counterparts. This finding supported the expectation that units supplied a CITV such as that used by the CVCC participants can effectively engage and destroy the enemy at greater and safer distances.

The two conditions were comparable with respect to percentage of OPFOR killed by direct fire from the manned simulators. Data on OPFOR kills by indirect fire were not available and not included in this measure. The potential for greater destruction of enemy units through indirect fire is an important aspect of digital C<sup>2</sup> systems that will be examined under the Fire Support BOS section. For more informative lethality assessments in future evaluations, operational definitions should be revised and broadened to capture and categorize by source all OPFOR kills.

Conditions were also comparable on results from the set of measures developed to assess the accuracy and effectiveness of direct fire by the manned simulators. In retrospect, the enhanced functionality provided by a CVCC simulator (see Table 2) may be limited with respect to intravehicular, direct-fire accuracy. CVCC's primary benefits were demonstrated with respect to target acquisition and processing: time to process multiple targets and acquisition at extended ranges. These capabilities combined with the intervehicular features of digital C<sup>2</sup> systems provide the basis for expectations of designated target hand-off and automated fire distribution within vertically and horizontally integrated units (Clark, 1993; U.S. Army Armor Center, 1994).

Given the equivalent kills/round ratios by the two conditions, the demonstrated ability of CVCC units to fire more main gun rounds evidenced the potential for greater lethality by CVCC units. The basis for more rounds fired would be difficult to pinpoint. Reasonable explanations of this effect might include the significantly greater ability of CVCC units to acquire targets at extended ranges and to hunt-and-kill multiple targets simultaneously. Information processing results, in subsequent sections, might attribute more rounds fired to the ability of vertically integrated units to collect, transmit and relay more accurate and more numerous reports on enemy locations and activities. The fact that CVCC units fired more rounds, further countered the concern that commanders and crews equipped with digital displays may lose track of the surrounding battlefield and enemy threat. Rather than the "loss of firepower" feared by some, more frequent direct fire was evidenced by vehicles equipped with automated C<sup>2</sup> systems.

### Fire Support BOS

Process Ground Targets. CVCC-equipped participants demonstrated significantly improved performance over Baseline participants in their ability to issue Call For Fire (CFF) reports that were complete and accurate under the process ground targets function of the Fire Support BOS. Mean values for selected measures under process ground targets are provided in Table 12 and source tables in Appendix H.

The accuracy of CFF locations was computed as the deviation between reported OPFOR locations in a CFF and actual OPFOR locations based on center-of-mass for the three OPFOR vehicles nearest the reported location. Accuracy determinations were based on CFFs originated by any participant commander, and excluded subsequent CFF relays. Only CFFs with grid-based locations were treated as "scorable" for location accuracy. Percentage of CFFs with correct enemy type such as tank or personnel carrier was based on comparison of reported enemy type with actual enemy types visible to commander at the time the CFF was issued. Only CFFs with grid-based locations and designated enemy type were treated as "scorable" for percentage correct. Accuracy and enemy type determinations were made by DCA routines that compared related report elements with actual battlefield events. For the CVCC condition, report elements were directly entered into the DataLogger database files as CCD-based CFFs were issued. Baseline report elements were obtained from audio playback tapes of each exercise and manually entered into DCA database files.

Overall mean error of CFF locations was 399 meters for CVCC participants and 139 meters for Baseline participants. This difference was neither in the direction expected nor significant. Any comparisons on CFF accuracy, however, must be caveated by the fact that Baseline participants issued very few "scorable" CFFs. The overall mean number of scorable CFFs per exercise was 2.0 for CVCC participants and .01 for the Baseline condition, Figure 17. These equate to a total of 28 scorable CFFs for CVCC participants compared with only 2 grid-based CFFs for the Baseline condition. A nonparameteric comparison, Pearson chi-square test, on number of scorable CFFs indicated that CVCC participants issued significantly more grid-based CFFs than Baseline participants ( $\chi^2 (1, N = 272) = 37.9, p = .00$ ).

Table 12

## Mean Performance for Process Ground Targets Measures, by Echelon and Condition

Measures	Battalion		Company		Platoon	
	CVCC	Baseline	CVCC	Baseline	CVCC	Baseline
Accuracy of Call for Fire (CFF) locations	270.58 (111.97) $n=3$	137.00 $n=1$	475.10 (433.03) $n=8$	141.00 $n=1$	372.33 (481.15) $n=17$	NA
Number of scorable CFFs requested	.11 (.32) $n=28$	.03 (.16) $n=40$	.29 (.46) $n=28$	.03 (.16) $n=40$	.30 (.46) $n=56$	NA
Percentage of CFFs with correct enemy type	40.00% (54.77) $n=5$	16.70% (28.90) $n=3$	52.67% (31.72) $n=10$	50.00% (70.71) $n=2$	84.26% (33.56) $n=18$	NA

Note. Standard deviations are in parentheses. NA indicates no data available for measure as defined and

Overall mean percentage of CFFs with correct enemy type was 68.0% for CVCC participants and 30.0% for Baseline participants, Figure 18. This difference was in the direction expected and significant ( $F 1, 36 = 3.81, p = .059$ ). Again, comparisons on percentage of CFFs with correct enemy type were limited by the fact that Baseline participants issued very few "scorable" CFFs.

In discussion, CVCC-equipped commanders were significantly better than their Baseline counterparts in the ability to process ground targets under the Fire Support BOS. The most distinctive aspect of CFFs by CVCC participants was their inclusion of grid-based locations for directing the requested artillery fires. Baseline commanders, on the other hand, issued very few CFFs with grid locations despite the battalion SOP's requirement that grids be included in the CFF format. Typically, Baseline CFFs attempted to designate enemy location relative to key terrain features or current control measures, such as target reference points, checkpoints and objectives.

Note, that "scorable" is not equivalent to useful. Fire Support Officers (FSOs) with accurate and current fire support and operational overlays can, with some difficulty, determine the grids associated with a specified control measure. When a CFF requests a "shift" from a control measure or a key terrain feature, the FSO's time and location error are generally compounded. Initial artillery rounds by voice-based units, therefore, are often adjusted repeatedly before an artillery battery can "fire for effect."

The emphasis on scorable CFFs was consistent with the advantage anticipated from vertical and horizontal integration in the processing of ground targets, first-round effective fires (Clark, 1993; U.S. Department of the Army, 1994). In the current evaluation, vehicle-based CFFs transmitted to the TOC by either test condition were then manually entered by the FSO into the MCC fire support station (see Table 1).

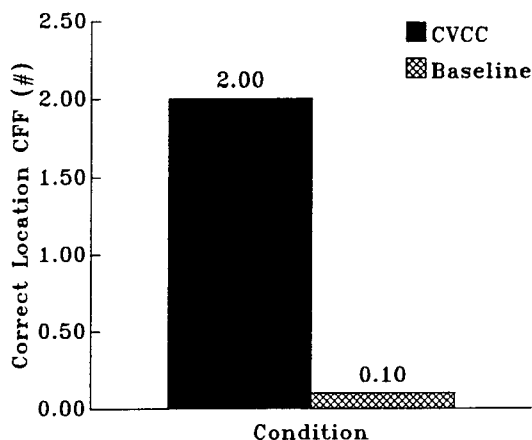

Figure 17. Mean number of Calls For Fire (CFF) per exercise with required grid location, by condition.

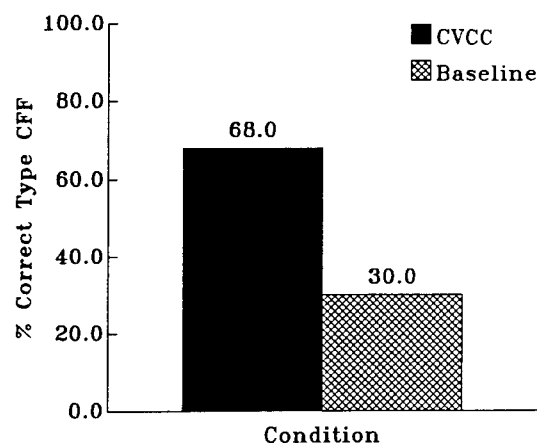

Figure 18. Mean percent of Calls For Fire (CFF) with correct enemy type, by condition.

Such "swivelchair" integration is not the objective of digital integration efforts. Automated entry of CFFs into a digitally integrated fire support station, however, will require grid-based enemy locations, at least in the near term. For conventionally-equipped commanders, the precise determination of an enemy location remains difficult and time-consuming. In contrast, the far-target designate feature of the CITV automatically generated lased-grids into CFF report formats.

As noted in the discussion of OPFOR kills by direct fire, data on OPFOR kills by indirect fire were not available. The actual utility or effectiveness of CFFs from either condition, therefore, was not determined. The argument for improved processing of ground targets by CVCC participants rests on the fact that they transmitted CFFs with more efficient and productive content. Future efforts should strive to fully integrate C<sup>2</sup> digital systems across BOS, to avoid swivel-chair integration and to ensure collection of data on the effectiveness of indirect fires.

### Command and Control BOS

Receive and transmit mission. CVCC-equipped participants demonstrated significantly improved performance over Baseline participants on all measures tested under the receive and transmit mission of the Command and Control BOS. Mean values for selected receive and transmit mission measures are provided in Table 13 and source tables in Appendix H.

Time to transmit Fragmentary Orders (FRAGOs) was cumulated across echelons to assess the overall elapsed time for mission transmission across all vertical echelons within the battalion. FRAGOs were initially transmitted by the battalion TOC over the battalion command net and simultaneously received by battalion and company command group participants operating on that net. Transmission time to the company commenced with the TOC's issue and continued until the company commander had completely received the FRAGO, as indicated by his acknowledgement. TOC-to-company

Table 13

## Mean Performance for Receive and Transmit the Mission Measures, by Echelon and Condition

Measures	Battalion		Company		Platoon	
	CVCC	Baseline	CVCC	Baseline	CVCC	Baseline
Time to transmit FRAGO (cumulative minutes)	0.0 <sup>a</sup>  n = 11	3.19 (1.72) n = 15	1.26 (1.29) n = 11	7.19 (4.83) n = 15	2.27 (1.51) n = 10	9.96 (5.17) n = 9
Duration of requests to clarify FRAGO (minutes)	0.0  n = 0	.31 (.17) n = 6	0.0  n = 0	.43 (.21) n = 2	0.0  n = 0	9.96 (.53) n = 4
Number of requests to clarify FRAGO	0.0  n = 0	.15 (.36) n = 40	0.0  n = 0	.05 (.22) n = 40	0.0  n = 0	.05 (.22) n = 80
Percentage of FRAGO elements correctly relayed	100.00 <sup>a</sup>	100.00 <sup>b</sup>	100.00 <sup>a</sup>	19.85 (9.29) n = 12	100.00 <sup>a</sup>	25.60 (22.20) n = 9

**Note.** Standard deviations are in parentheses.

<sup>a</sup>CVCC's CCD-based Intelligence (INTEL) reports were transmitted correctly over the Ethernet.

<sup>b</sup>Scripted Intel reports transmitted by Tactical Operations Center (TOC).

transmission time, therefore, included any time taken by the company commander to request clarification of the FRAGO and the time required to provide such clarification. Transmit time from the battalion TOC to the platoon included TOC-to-company FRAGO transmission time and all transmit and clarification time required for platoon leader's FRAGO reception and acknowledgement. Similarly, FRAGO transmit time to the tank commanders, included TOC-to-platoon FRAGO transmission time and all transmit and clarification time required for tank commanders' reception and acknowledgement.

FRAGOs for the CVCC condition included a CCD operational overlay with an accompanying Free Text message. Transmission and reception times for these digital messages were directly entered into the DataLogger database files. Any follow-up clarifications and acknowledgements of FRAGOs in the CVCC condition, however, were made over voice-based radio. Time required for FRAGO clarifications was obtained from audio playback tapes of each exercise and manually entered into DCA database files to complete computation of full FRAGO transmission time. For the Baseline condition, FRAGOs and related clarifications and acknowledgements were transmitted exclusively on voice-based radio and transmit times were obtained from audio playback tapes for manual entry into DCA database files.

Mean FRAGO transmit times by echelon and condition are depicted in Figure 19. For the Baseline condition, mean FRAGO transmit time to battalion and company

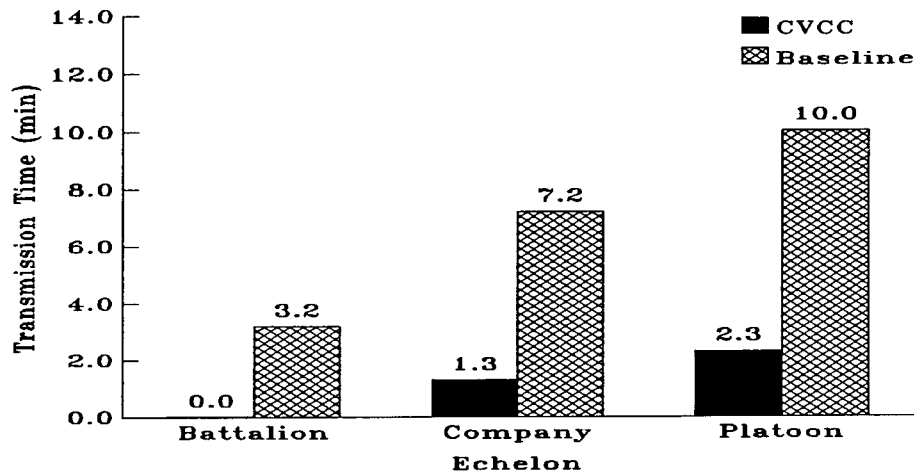

Figure 19. Mean cumulative time to transmit Fragmentary Order (FRAGO), by echelon and condition.

command groups was 3.2 minutes which included time to vocalize and clarify the order. In contrast, CVCC battalion and company command groups received digital burst FRAGOs from the TOC. TOC-to-company FRAGO transmission times for the CVCC condition were, therefore, virtually "instantaneous" as there were no requests by CVCC commanders for FRAGO clarification. Mean FRAGO transmit time to the platoon was 1.3 minutes for CVCC participants and 7.2 minutes for Baseline participants. This difference was in the direction expected and significant ( $F_{2, 263} = 13.10, p = .00$ ). Mean FRAGO transmit time to the tank commanders was 2.3 minutes for CVCC participants and 10.0 minutes for Baseline participants. This difference was also in the direction expected and significant ( $F_{2, 263} = 13.10, p = .00$ ).

Duration of requests for FRAGO clarification were based on elapsed time between a commander's issue of the request to his acknowledgement of the clarification provided. This measure, a component included under FRAGO transmission time, was maintained separately to assess the clarity of mission communications. Number of requests for FRAGO clarification was a tally of such requests. Both measures were obtained from audio playback tapes of each exercise and manually entered into DCA database files.

No requests for FRAGO clarification were made by CVCC participants. The mean duration of Baseline clarification requests were 18.6 seconds at the battalion echelon, 25 seconds at the company echelon, and 30 seconds at the platoon echelon. The total number of Baseline FRAGO clarifications requested were 12: 6 at the battalion echelon, 2 at the company echelon, and 4 at the platoon echelon. Due to the limited number of requests for FRAGO clarification, differences between conditions was assessed across echelons using the Mann-Whitney test. Overall, both the number and duration of requests for FRAGO clarification by Baseline participants was significantly greater than the CVCC condition,  $U_s(109, 160) = 8066, p = .004$ .

Percentage of FRAGO elements correctly relayed was based on a comparison of scripted FRAGO content as issued by the TOC with the content of FRAGOs as relayed by participant commanders (see Appendix C). Separate scoring templates were developed for company versus platoon level FRAGO content. At the company level, the content of FRAGOs from the TOC was parsed into discrete elements, ranging from 14-36 elements per exercise. For platoon FRAGOs, a subset of TOC FRAGO content that related primarily to B Company was parsed into discrete elements, ranging from 5-15 elements per exercise. Required elements were dichotomously scored with respect to accurate and recognizable relay. For the CVCC condition, CCD-based FRAGOs could not be edited by vehicle-based commanders and any subsequent relays were identical, correctly relayed, to the original FRAGO. Comparisons were limited to FRAGO relays by company commanders and platoon leaders.

The mean percentage of FRAGO elements correctly relayed by Baseline company commanders to their platoon leaders and subsequently by these platoon leaders to their wingmen were 20% and 26%, respectively. The slightly more accurate relay of FRAGOs by platoon leaders was possible since platoon level FRAGOs were scored against a subset of the FRAGO elements required at the company level. The assumption of perfectly consistent relays by CVCC company commanders and platoon leaders equated to significantly less accurate FRAGO relay by their Baseline counterparts,  $U(28, 20) = 0.0, p = .000$ .

In discussion, CVCC participants performed significantly better than Baseline participants on all measures tested under the receive and transmit mission of the Command and Control BOS. Results on time to transmit the FRAGOs forcefully demonstrated the potential of digital C<sup>2</sup> systems to expedite the issue of orders in preparation for combat operations. In conjunction with results on the accuracy of FRAGO communications and requests for clarification, the overall pattern of results on receive and transmit the mission strongly confirmed the expectation that voice radio severely limits the ability of a combat unit to issue orders rapidly, clearly and accurately.

The impact of vertically integrating a unit was clearly evident in findings on time to transmit FRAGOs. Baseline units experienced significant delays in FRAGO transmission at each echelon within an armor battalion. Time to transmit a FRAGO by conventionally-equipped participants consistently averaged over three minutes at each of the battalion's echelons. The evaluation's focus on vertical integration provided a unique opportunity to accrue the impact of such delays across an entire battalion-size unit.

Clarity in mission communication was demonstrated by the number of requests for FRAGO clarification. While CVCC commanders issued no such requests, Baseline commanders at each battalion echelon sought additional clarification of the orders they received. The design's focus on FRAGOs precluded the dismount often associated with the issue of orders for more deliberate operations. Background discussion attempted to portray the difficulty conventionally-equipped units have plotting voice-based control measures into an operational overlay that graphically illustrates the intent of orders issued. In contrast, the graphic overlay and text included in all CVCC FRAGO

transmissions, apparently, conveyed the intent and requirements of the mission with sufficient clarity, as no clarifications were requested.

Findings on the percentage of FRAGO elements correctly relayed provided a more direct measure of the inaccuracies inherent in voice-based communications. Overall, Baseline company and platoon commanders consistently relayed less than one-fourth of the information initially provided by the TOC's FRAGO. The "fragmentary" content of FRAGOs relayed by Baseline commanders braced the premise that digital C<sup>2</sup> systems are needed to ensure that all echelons in a vertically integrated unit receive an accurate account of the orders issued.

How could Baseline units attempt to execute the FRAGOs assigned given the low percentage of FRAGO content they correctly relayed? The FRAGOs issued by the TOC included a level of information on the friendly and enemy situation that commanders might have summarized or paraphrased in a manner that prevented "acceptable" scoring for some elements. The company level FRAGO, in particular, included coordination information on adjacent units that commanders may not have regarded as critical for subsequent relay. With voice-based C<sup>2</sup>, commanders at each echelon determine what information to relay or not relay.

Information retained, however, is often lost with attrition of personnel and equipment. A more realistic setting than that experienced with the "kill suppress" feature, used in this evaluation to standardize connectivity, might disclose the shortcomings in C<sup>2</sup> and mission reception due to attrition. A more extended operational setting than that imposed by the evaluation exercises might highlight deficiencies in company-level coordination. If such settings result in more complete FRAGO transmissions, however, the limitations documented for voice-based FRAGO transmission time and clarification would be amplified.

Receive and transmit enemy information. Comparisons of CVCC and Baseline performance resulted in mixed findings across the set of measures tested under the receive and transmit enemy information function of the Command and Control BOS. The conditions demonstrated comparable performance on time to relay bottom-up reports--Contact, Spot and Shell--on enemy units. CVCC participants, however, did relay a significantly greater number of such reports on enemy units. On top-down Intelligence reports originated by the TOC, Baseline units demonstrated serious limitations in their ability to relay enemy information accurately. Mean values for selected receive and transmit enemy information measures are provided in Table 14 and source tables in Appendix H.

Time to relay Contact, Spot and Shell reports was defined as the elapsed time between each report's transmission on one radio net to its subsequent transmission on another radio net. For example, relay time for a Contact report might include the time from the platoon leader's transmission of a Contact report on the company net to the time the company commander relayed this information to his superiors on the battalion net. For the CVCC condition, the CCD-based transmission times for these digital

Table 14

Mean Performance for Selected Receive and Transmit Enemy Information Measures, by Echelon and Condition

Measures	Battalion		Company		Platoon	
	CVCC	Baseline	CVCC	Baseline	CVCC	Baseline
Time to relay Contact report (minutes)	.66 (.32) <u>n</u> =3	.98 (.76) <u>n</u> =11	.62 (.58) <u>n</u> =17	.64 (.42) <u>n</u> =7	.36 (.13) <u>n</u> =5	.48 (.41) <u>n</u> =3
Time to relay Spot report (minutes)	1.87 (1.13) <u>n</u> =5	.22 <u>n</u> =1	.89 (.67) <u>n</u> =14	1.05 (.44) <u>n</u> =3	1.12 (1.48) <u>n</u> =8	1.43 <u>n</u> =1
Time to relay Shell report (minutes)	.80 (.82) <u>n</u> =3	.90 <u>n</u> =1	.25 (.12) <u>n</u> =2	.68 <u>n</u> =1	NA	1.15 <u>n</u> =1
Duration of requests to clarify INTEL reports (minutes)	0.0 <u>n</u> =0	.05 (.13) <u>n</u> =40	0.0 <u>n</u> =0	.02 (.10) <u>n</u> =40	0.0 <u>n</u> =0	.03 (.15) <u>n</u> =80
Number of requests to clarify INTEL reports	0.0 <u>n</u> =0	.15 (.36) <u>n</u> =40	0.0 <u>n</u> =0	.05 (.22) <u>n</u> =40	0.0 <u>n</u> =0	.05 (.22) <u>n</u> =80
Percentage of INTEL report elements correctly relayed	100.00 <sup>a</sup>	100.00 <sup>b</sup>	100.00 <sup>a</sup>	62.50 (12.50) <u>n</u> =3	100.00 <sup>a</sup>	50.00 <u>n</u> =3

**Note.** Standard deviations are in parentheses. NA indicates no data available for measure as defined and tested. <sup>a</sup>CVCC's CCD-based Intelligence (INTEL) reports were transmitted correctly over the Ethernet.

<sup>b</sup>Scripted Intel reports transmitted by Tactical Operations Center (TOC).

messages were directly entered into the DataLogger database files. Transmission times for the Baseline condition's voice-based reports were determined from time-stamped transcriptions of audio playback tapes and entered into DCA database files.

The overall mean time to relay Contact reports was 34.0 seconds for CVCC participants and 47.4 seconds for the Baseline condition (see Figure 20). This difference was in the direction expected but not significant. The overall mean time to relay Spot reports was 66.0 seconds for CVCC participants and 60.4 seconds for the Baseline condition. This difference was neither in the direction expected or significant. The overall mean time to relay Shell reports was 34.8 seconds for CVCC participants and 54.6 seconds for the Baseline condition (see Figure 20). This difference was also in the direction expected but not significant. Interpretation of the results on time to relay these bottom-up reports should include consideration of the number of reports, the amount of information, relayed by condition.

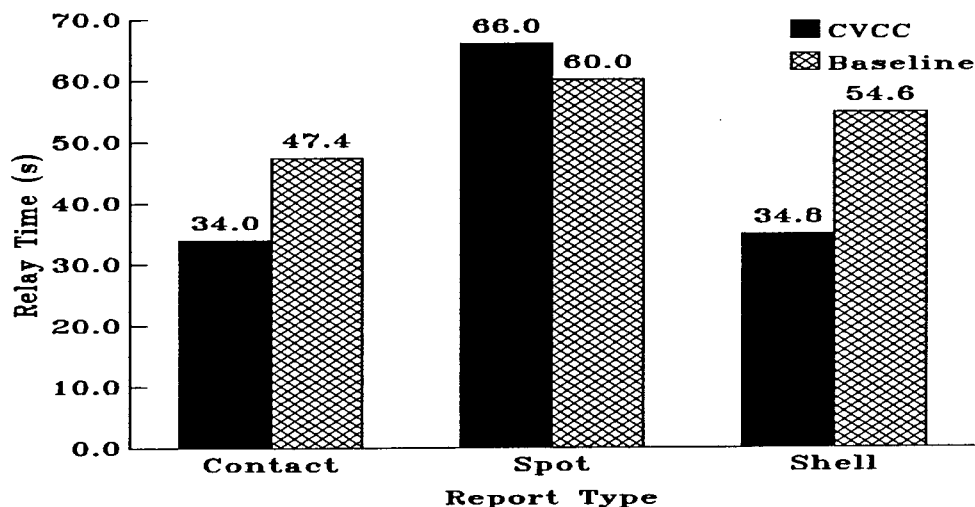

Figure 20. Mean time to relay reports between echelons, by report type and condition.

Overall mean number of all Contact, Spot and Shell reports relayed was .52 for the CVCC condition and .18 for the Baseline condition. This difference was in the direction expected and significant ( $F 1, 266 = 26.47, p = .000$ ). The effect of Echelon was significant ( $F 2, 266 = 22.78, p = .00$ ) and a simple test of main effect revealed that the number of reports relayed by company-level participants was significantly greater than the number relayed by battalion ( $F 1, 269 = 7.86, p = .01$ ) and platoon level participants ( $F 1, 269 = 12.01, p = .00$ ). The Condition by Echelon effect was also significant ( $F 2, 266 = 3.70, p = .000$ ). Simple effects tests of Condition within Echelon disclosed that CVCC company level commanders relayed a significantly greater number of enemy reports than their Baseline counterparts, ( $F 1, 266 = 41.49, p = .000$ ).

Duration of requests for clarification of Intelligence (INTEL) reports was based on elapsed time between a commander's issue of the request for clarification to his acknowledgement of the clarification provided. Number of requests to clarify INTEL reports was a count of participant commanders' requests for clarification of received Intelligence reports. Clarification duration and number of requests were based on audio playback tapes of each exercise and manually entered into DCA database files.

No requests for INTEL clarification were made by CVCC participants. The mean duration of Baseline clarification requests was 20.4 seconds at the battalion echelon, and 15 seconds at the platoon echelon. At the company level, no INTEL clarifications were requested by Baseline participants. The total number of Baseline INTEL clarifications requested were 4: 2 at the battalion echelon and 2 at the platoon echelon. No analyses of the data for these two measures were attempted.

Percentage of INTEL elements correctly relayed compared the content of INTEL reports transcribed from audio replays against the TOC's scripted INTEL content (see Appendix D). INTEL content was parsed into discrete elements, ranging from 9-14 per exercise, and each element was dichotomously scored with respect to accurate and recognizable relay. For the CVCC condition, CCD-based INTELS could not be edited

by vehicle-based commanders and any subsequent relays were identical to the original INTEL report. For both conditions, battalion and company commanders simultaneously received the scripted INTEL issued by the TOC on the battalion command net. Comparisons, therefore, were limited to correctness of INTEL relays by company commanders and platoon leaders.

The mean percentage of INTEL elements correctly relayed by Baseline company commanders to their platoon leaders and subsequently by these platoon leaders to their wingmen were 63% and 50%, respectively. In comparison to the perfectly consistent Intelligence report relays provided by CVCC company commanders and platoon leaders, their Baseline counterparts relayed significantly less accurate Intelligence report information,  $U(28, 6) = 0.0, p = .000$ .

In preface to discussion, a more complete assessment of conditional differences in the processing of threat information will require consideration of results provided under the collect threat information function, in the subsequent Intelligence BOS section. For the set of measures tested under the receive and transmit enemy information function of the Command and Control BOS, results were mixed. Although the two conditions were essentially equivalent in time required to relay Contact, Spot and Shell reports, CVCC commanders relayed significantly more of these bottom-up reports on enemy units and activities. Additionally, Baseline commanders evidenced severe limitations in accurately relaying top-down reports on enemy units.

The failure to find differences in time taken to relay bottom-up reports was not expected, but bears discussion. Prior CVCC-related evaluations have also failed to establish the relative advantage of  $C^2$  digital systems for the initial transmission of Contact, Spot and Shell reports. While the company-level evaluation reported that CVCC commanders were significantly faster reporting contact in an offensive scenario, there was no difference in a defensive scenario (Leibrecht, et al., 1992). A platoon-level evaluation also found no advantage for Spot or Shell report transmit times (Du Bois & Smith, 1991).

In contrast to these prior assessments of transmit time, the measures developed for this evaluation addressed relay time, the time from a report's initial transmission on one net to its subsequent transmission on another net. The intent of relay time measures was to address the cumulative effect of vertical integration across the primary radio nets used by the battalion, such as time from initial transmission of a Contact report on the platoon net until that information was received on the battalion net.

A reality of combat operations, even when simulated, is that commanders must allocate time and attention to many tasks besides the transmission, reception and relay of combat reports. Cuing events for Contact and Shell reports, in particular, are imminent threat situations and commanders frequently initiate a counter-response prior to transmitting or relaying related reports. In contrast, Spot reports are often regarded as after-the-fact accounts of less urgency. Table 14 provides a basis for such a comparison

in the means and standard deviations obtained on the relay times taken for Spot versus Contact and Shell reports.

The rapid and accurate relay of enemy information, however, is a prominent objective in the fielding of digital C<sup>2</sup> systems. In fact, digital C<sup>2</sup> systems can relay information automatically from one net to the next. For the CVCC condition, position location updates and logistic reports were automatically relayed across echelons during this evaluation and the prior evaluation on horizontal integration of digital C<sup>2</sup> systems in an armor battalion. Future efforts might address the effect of automated relays of enemy information on reducing relay time and the workload of the commander-in-the-middle who currently performs such relays.

CVCC-equipped commanders did relay a significantly higher number of Contact, Spot and Shell reports than the Baseline condition. The fact that CVCC participants relayed more information on enemy units and activities bolstered the expectation that digital systems will improve visualization of battlespace. In the vertically integrated CVCC battalion, commanders relayed and received more of the information on enemy location, type, size and activity that is critical to their awareness of the enemy situation.

With respect to receiving and transmitting INTEL reports, the performance of the Baseline condition disclosed serious shortcomings in voice-based relays. The consistency of CVCC's digital relays of INTEL reports provided significantly more accurate descriptions of enemy units and their activities than the relays by voice-based commanders. In addition, comparisons on the requests for INTEL clarification were severely limited by the fact that very few of the scripted INTELS were relayed by the Baseline commanders. The limitations in voice-based reception and transmission of top-down enemy information also supported the potential of digital C<sup>2</sup> systems to provide vertically integrated echelons a more accurate visualization of the enemy situation.

Receive and transmit friendly troop information. CVCC-equipped participants demonstrated significantly improved performance over Baseline participants on several important measures tested under the receive and transmit friendly troop information function of the Command and Control BOS. In particular, results on voice communications between the battalion echelon and the TOC convincingly documented the efficiency in communication derived with the CVCC system. Mean values for selected receive and transmit friendly troop information measures are provided in Table 15 and source tables in Appendix H.

Deviation of BLUFOR location in a Situation report (SITREP) was defined as the distance between actual and reported Forward Line of Own Troops (FLOT). Scorable FLOTs required designation of two grid locations indicating the flank locations of the unit's most forward vehicles. FLOT accuracy determinations were made by DCA routines that calculated the deviation between the midpoints of reported and actual FLOT locations. For the CVCC condition, FLOT locations were directly entered into the DataLogger database files as CCD-based SITREPs were issued. Baseline FLOT locations were extracted from audio playback tapes of each exercise and manually

Table 15

## Mean Performance for Selected Receive and Transmit Friendly Troop Information Measures, by Condition

Measures	CVCC	Baseline
Deviation of BLUFOR location in Situation report (meters)	1653.52 (1431.84) $\underline{n}=6$	NA
Delay between observed and reported checkpoint arrival (minutes)	NA	.208 (.25) $\underline{n}=2$
Number of voice communications between battalion echelon and TOC	.07 (.27) $\underline{n}=1$	2.22 (2.18) $\underline{n}=18$
Duration of voice communications between battalion echelon and TOC	.178 (.12) $\underline{n}=11$	.372 (.28) $\underline{n}=98$

Note. Standard deviations are in parentheses. NA indicates no data available for measure as defined and tested.

entered into DCA database files. Mean deviation of BLUFOR location for the CVCC condition is provided in Table 15; the Baseline condition reported no scorable FLOT grid-based locations. No analysis of the this data was attempted.

Delay between observed and reported checkpoint arrival was defined as elapsed time between from when a unit's lead vehicle reached a checkpoint to the time the unit reported the checkpoint. Actual and reported arrival times at checkpoints were based on flags entered into the database files by the PVD operators. The Baseline condition reported two checkpoint arrivals with delays of 22.8 and 1.8 seconds. No checkpoint arrivals recorded for the CVCC condition and analysis of this data was not attempted.

The number of voice communications between the battalion echelon and the TOC was a tally of all voice communications, complete messages, between the battalion echelon commanders and the members of the TOC. Typically these communications concerned unit coordination, analysis and general information sharing. They excluded scripted reports such as FRAGOs and INTELs and the communication of formal or named reports such as CFF, Contact, Spot and Shell. For both conditions, the number of voice communications by exercise was obtained from audio playback tapes and manually entered into DCA database files.

The mean number of voice communications between the battalion echelon and the TOC per exercise was .01 for the CVCC condition and 2.2 for the Baseline condition (see Figure 21). Due to the extremely low incidence of such communications during the CVCC exercises (see Table 15) a nonparametric Mann-Whitney tests was used to analyze the difference between conditions. The difference in number of voice communications

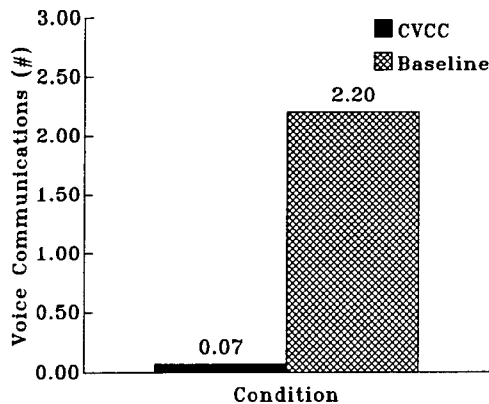

Figure 21. Mean number of voice communications between battalion echelon and TOC, excluding named and scripted reports, by condition.

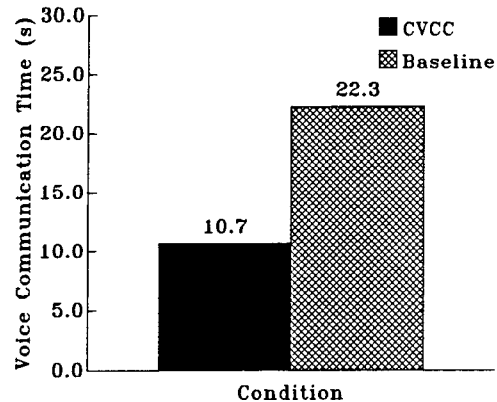

Figure 22. Mean duration of voice communications between battalion echelon and TOC, excluding named reports, by condition.

between the battalion echelon and the TOC was significant,  $U(14, 18) = 45.5, p = .00$ , and in the direction expected.

The duration of voice communications between the battalion echelon and the TOC was defined as the time required for each communication, complete message, between the battalion echelon commanders and the TOC. The time required for scripted FRAGO and INTEL communications was included but not the time required for nonscripted, named reports. For both conditions, the duration of voice communications was based on time-stamped transcriptions from audio playback tapes and manually entered into DCA database files. The mean duration of these communications was 10.7 seconds for the CVCC condition and 22.3 seconds for the Baseline condition (see Figure 22). This difference was in the direction expected and significant ( $F(1, 107) = 5.0, p = .03$ ).

In discussion, the CVCC condition demonstrated significantly improved performance over Baseline participants on several important measures tested under the receive and transmit friendly troop information function of the Command and Control BOS. Overall, the results supported the capacity of digital  $C^2$  systems to automate and expedite the transmission of information about the status and situation of friendly troops in a vertically integrated unit.

Results on the accuracy of FLOT locations in SITREPs indicated that Baseline commanders never transmitted a grid-based FLOT. In addition, there were only two instances in which Baseline commanders reported checkpoint arrivals. Given the restricted monitoring capabilities of voice-based battalion echelon commanders and their TOC, the need for relatively precise locations of own troops is critical. Maneuver commanders and their staffs, in particular, need accurate information on own troop locations almost continuously. Such information impacts their ability to coordinate adjacent units, to clear CFFs, to lift and shift protective fires, to emplace obstacles, to

employ close air support, to direct link-up and resupply, and in general to execute the current mission and prepare for the next.

In contrast to the Baseline unit, the CVCC battalion command group and TOC routinely received accurate updates that graphically depicted the location of all the battalion's friendly vehicles and units on their CCD's and TOC workstations' tactical maps. Although CVCC commanders transmitted six grid-based FLOTs, the information in the FLOT of a CVCC SITREP is essentially redundant with that provided by the mutual POSNAV updates on the tactical display. The same argument holds for the conventional requirement to report arrival at a checkpoint, crossing a line of departure or a phase line, reaching an objective, and numerous other communications related to control measures. The CCDs and TOC workstations depicted vehicle and unit locations in relation to the control measures included on all displayed operational, obstacle, fire support and other overlays.

Results on the number and duration of communications between the battalion command group and TOC strikingly supported the potential efficiency of digital C<sup>2</sup> systems in exchanging friendly and related information over voice-based C<sup>2</sup> systems. CVCC reductions in time and amount of such communications might be due partly to the capability of directly monitoring friendly locations and the course of mission execution on the CCDs and TOC workstations. These reductions were probably also due to the CVCC Logistic reports that automatically compiled and routinely relayed to the battalion command group and TOC the status of friendly ammo, fuel, equipment and personnel (Leibrecht et al., 1994).

In summary, empirical and practical comparisons on receive and transmit friendly troop information evidenced the potential of digital C<sup>2</sup> systems, relative to voice-based radio, to improve performance on this essential C<sup>2</sup> function and enable the commander to better visualize the friendly situation. Vertical integration of the CVCC battalion precluded the need for many of the conventional reports on friendly unit location, status and progress. Vertical integration provided the automatic relay of this information to the battalion's command group and staff and drastically reduced their requirement to share and coordinate friendly and related information through voice communications.

Manage means of communicating information. CVCC-equipped participants demonstrated significantly improved performance over Baseline participants on most of the measures tested under the manage means of communicating information function of the Command and Control BOS. Mean values for selected manage means of communicating information measures are provided in Table 16 and source tables in Appendix H.

The duration of voice radio transmissions on each radio command net was defined by noninterrupted keying of a radio microphone by a participant commander. Transmission duration and number, therefore, were often based on message segments--complete messages frequently required multiple transmissions. The number of voice radio transmissions on each command net was a tally of noninterrupted keyings of a

Table 16

Mean Performance for Manage Means of Communicating Information Measures, by Echelon and Condition

Measures	Battalion		Company		Platoon	
	CVCC	Baseline	CVCC	Baseline	CVCC	Baseline
Duration of voice radio transmissions (seconds)	3.99 (.67) $\underline{n}=15$	4.22 (.45) $\underline{n}=20$	3.25 (.28) $\underline{n}=15$	3.69 (.73) $\underline{n}=20$	3.23 (.70) $\underline{n}=15$	3.68 (.59) $\underline{n}=20$
Number of voice transmissions	107.29 (30.34) $\underline{n}=14$	141.35 (19.92) $\underline{n}=20$	94.57 (28.94) $\underline{n}=14$	108.10 (25.39) $\underline{n}=20$	63.29 (32.66) $\underline{n}=14$	101.70 (32.07) $\underline{n}=20$
Net time on voice radio (minutes)	7.28 (2.98) $\underline{n}=14$	9.97 (2.03) $\underline{n}=20$	5.23 (1.78) $\underline{n}=14$	6.52 (1.40) $\underline{n}=20$	3.44 (1.60) $\underline{n}=14$	6.25 (2.14) $\underline{n}=20$
Number of named voice reports	.32 (1.07) $\underline{n}=25$	.57 (.87) $\underline{n}=40$	.46 (.69) $\underline{n}=28$	2.75 (2.37) $\underline{n}=40$	.52 (.93) $\underline{n}=56$	1.65 (1.80) $\underline{n}=80$

Note. Standard deviations are in parentheses.

radio microphone by a participant commander. The total time spent on a voice radio net was approximated by multiplying the total number of voice transmissions by their mean duration, and equated to voice "net time" on each combat net. All three of these measures excluded keying durations less than one second and greater than 30 seconds to eliminate, respectively, isolated key "clicks" and potential outliers caused by inadvertent extended keying that resulted in "hot mikes." For both conditions, these measures were based on instrumented microphone keying data automatically entered into DCA database files.

The mean duration of voice transmissions across the three primary combat radio nets of concern--battalion, company and platoon--was 3.5 seconds for the CVCC condition and 3.9 for the Baseline condition. This difference was in the direction expected and significant, ( $F_{1, 32} = 9.81, p = .00$ ). Mean durations for each of these nets by condition are depicted in Figure 23. As expected, the duration of CVCC voice transmissions on each of these nets was shorter than the Baseline condition but not significantly different at the individual net level. Similar data was obtained for the brigade and battalion Operations and Intelligence (O&I) nets. Mean duration of voice transmissions on the brigade net was 3.6 seconds for the CVCC condition and 3.8 for the Baseline condition. On the battalion O&I net, the mean duration of voice transmissions was 3.4 seconds for the CVCC condition and 3.8 for the Baseline condition. Differences on the brigade and O&I nets were in the direction expected but not significant.

The mean number of voice transmissions per exercise across the battalion, company and platoon nets was 88.4 for the CVCC condition and 117.1 for the Baseline

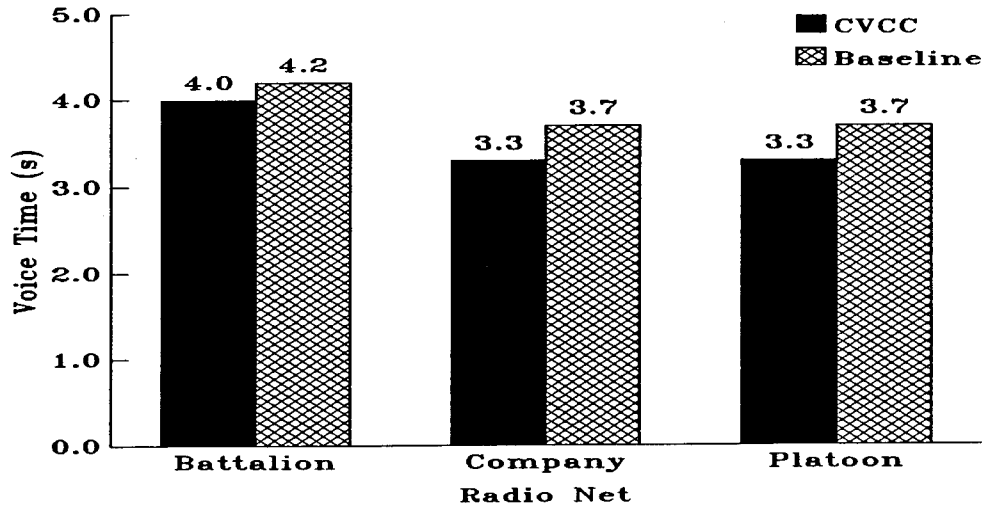

Figure 23. Mean duration of voice transmissions per exercise, by radio net and condition.

condition. This difference was in the direction expected and significant, ( $F$  1, 32 = 13.97,  $p$  = .00). Mean number of voice transmissions for each of these nets by condition are depicted in Figure 24. As expected, the number of CVCC voice transmissions for each of these nets was shorter than the Baseline condition, and significantly shorter for the battalion ( $F$  1, 32 = 15.68,  $p$  = .00) and platoon nets ( $F$  1, 32 = 11.64,  $p$  = .00). The brigade net was less active than the lower echelon nets and averaged 27 voice transmissions per exercise by CVCC participants compared to the Baseline average of 25 transmissions. This difference was neither in the direction expected or significant. On the battalion O&I net, the mean number of voice transmissions was 10.1 for the CVCC condition and 37.1 for the Baseline condition, a significant difference ( $F$  1, 32 = 21.61,  $p$  = .00) in the direction expected.

Mean voice net time per exercise across the battalion, company and platoon nets was 5.3 minutes for the CVCC condition and 7.6 minutes for the Baseline condition, a significant difference, ( $F$  1, 32 = 20.21,  $p$  = .000). Average voice net times on each of these nets are depicted in Figure 25. As expected, CVCC voice net times were significantly shorter than the Baseline on the battalion ( $F$  1, 32 = 9.85,  $p$  = .00), company ( $F$  1, 32 = 5.54,  $p$  = .03) and platoon nets ( $F$  1, 32 = 17.28,  $p$  = .000). Mean voice time on the brigade net was 1.8 minutes for the CVCC condition and 1.5 minutes for the Baseline condition, neither in the direction expected or significant. Battalion O&I voice time was 2.2 minutes for CVCC condition and 1.6 minutes for the Baseline, a significant difference ( $F$  1, 32 = 24.32,  $p$  = .000) in the direction expected.

The number of named voice reports was a tally of all named reports transmitted by the participant commanders during each exercise. Named reports available on the CCD included Contact, Spot, Shell INTEL, SITREP, Ammunition, Fuel, NBC and CFF reports. For the CVCC condition, transmission of such a report indicated a participant commander's decision to send that report by voice versus the analogous CCD-based report format. For both conditions, the number of named voice reports was based on transcriptions from audio playback tapes and manually entered into DCA database files.

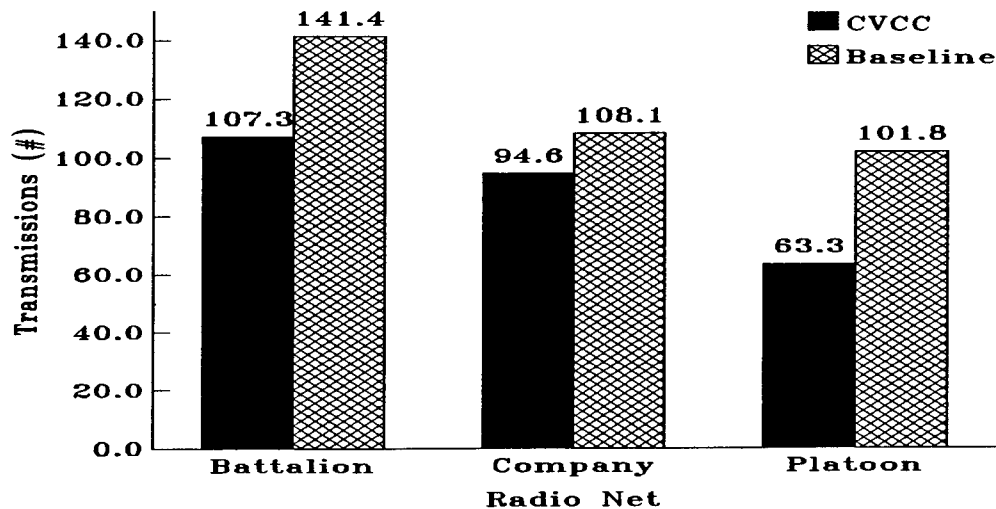

Figure 24. Mean number of voice transmissions per exercise, by radio net and condition.

Mean number of named voice reports per exercise across the battalion, company and platoon nets was .46 for the CVCC condition and 1.7 for the Baseline condition. This difference was in the direction expected and significant, ( $F$  1, 263 = 38.28,  $p$  = .000). Average number of named voice reports on each of these nets are depicted in Figure 26. The effect of Echelon was significant ( $F$  2, 263 = 9.49,  $p$  = .00) and a simple test of main effect revealed that the number of named voice reports on the battalion net was significantly fewer than the number on company ( $F$  1,266 = 21.69,  $p$  = .000) and platoon nets ( $F$  1, 266 = 8.08,  $p$  = .005). The Condition by Echelon effect was also significant ( $F$  2, 263 = 7.37,  $p$  = .001). Simple effects tests of Condition within Echelon disclosed that both CVCC company and platoon nets transmitted significantly fewer voice reports than their Baseline counterparts, respectively ( $F$  1, 263 = 38.11,  $p$  = .000) and ( $F$  2, 263 = 18.70,  $p$  = .000).

In discussion, the performance by CVCC participants demonstrated significantly more efficient management of voice radio compared to the Baseline condition on most measures tested under the manage means of communicating information function of the Command and Control BOS. Overall, results on duration of voice radio transmissions demonstrated that participants in the CVCC battalion maintained significantly better radio "discipline" than the Baseline condition while communicating by voice. When communicating over conventional voice radios, transmission duration equates to length of the electronic signature emitted by an activated microphone. To reduce such signatures, soldiers are trained to "break" their messages into small transmissions. Such breaks also increase the access of others to the same net for potentially more urgent communications.

Results on mean number of voice transmissions also indicated that CVCC's communication features reduced the amount of voice transmissions on each of the battalion's primary combat radio nets and the O&I net. When data on number of transmissions and voice duration were combined, total time on voice radio net provided a useful summary measure of CVCC's impact on voice net time. Significant reductions

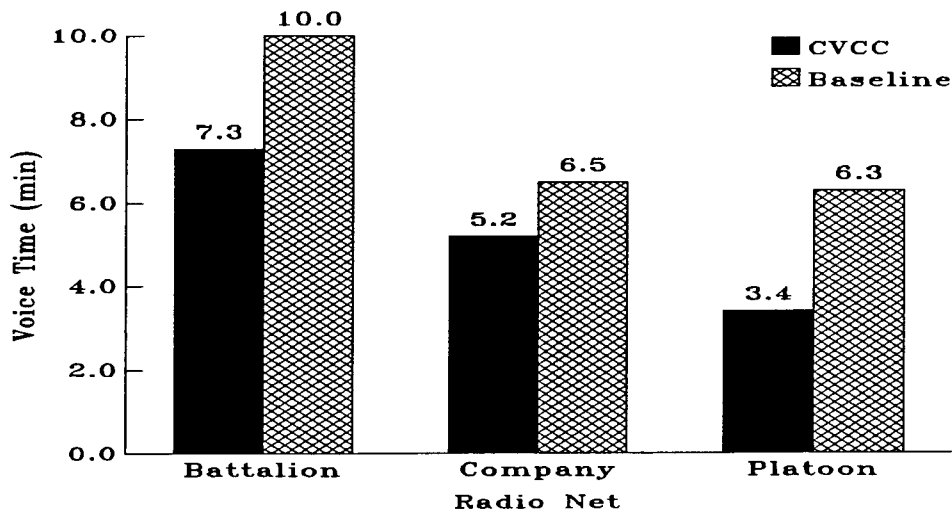

Figure 25. Mean total time of voice transmissions per exercise, by radio net and condition.

in CVCC voice net time were demonstrated at each of the primary battalion nets and the O&I net. The reductions at the battalion and platoon nets were the most impressive, 27% and 46%, respectively.

CVCC's reductions in voice net time may ultimately reduce combat radio net signatures and improve net access. The impact of digital C<sup>2</sup> systems on electronic signatures and net access, however, was neither simulated or assessed in this evaluation, but warrants comment and field testing. Admittedly, when digital C<sup>2</sup> systems are used under more realistic and/or field conditions, voice net time may simply be shifted to a digital transmission on the same net for some communications. The duration of a digital burst transmission, however, is shorter than a comparable voice message. Overall net time for an equivalent mix of voice and digital communications may prove significantly less than a voice-only system.

Results on number of named voice reports disclosed that CVCC participants transmitted significantly fewer of these reports than the Baseline commanders, and reductions at the company and platoon level were pronounced. Findings on number of reports under the Fire Support BOS and Collect Threat Information BOS indicated that CVCC commanders issued more named reports than the Baseline and used the CCD for the majority of such communications. Similarly, data from the battalion-level horizontal integration evaluation found that CVCC company level commanders transmitted 80% of their named reports using the CCD rather than voice radio (Leibrecht et al., 1994). As reported in that evaluation, CVCC commanders' debrief comments suggested that often their decision to use voice was based on the need to indicate the urgency of a communication. Even when submitting a report by voice, the CVCC commander can provide grid-based locations using far-target designate and a digital report field.

In summary, results on managing the means of communicating information provided solid evidence that digital C<sup>2</sup> systems may reduce the amount of information communicated by vehicle-based commanders over voice radio. The extent to which such

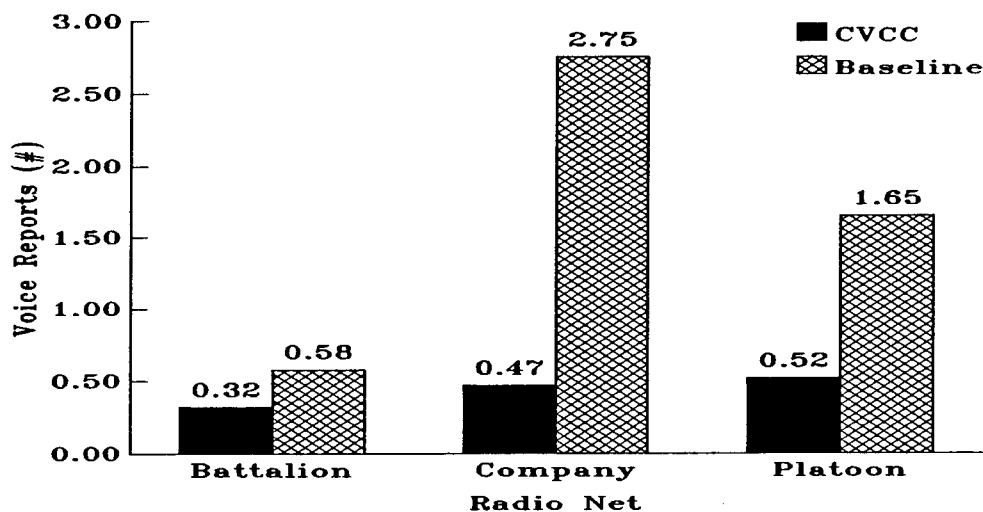

Figure 26. Mean number of named voice reports per exercise, by radio net and condition.

reductions might impact electronic detection and a unit's susceptibility to electronic countermeasures should be investigated in future efforts. Reductions in overall net time and transmission duration should improve access to the combat radio nets. During the battalion-level horizontal integration evaluation, CVCC company level commanders were especially impressed by the "quiet" command nets and the ready access to them (Leibrecht et al., 1994).

### Intelligence BOS

Collect threat information. CVCC-equipped participants demonstrated significantly improved performance over Baseline participants on several important measures tested under the collect threat information function of the Intelligence BOS. Mean values for selected collect threat information measures are provided in Table 17 and source tables in Appendix H.

The accuracy of Contact and Spot report locations was computed as the deviation between the enemy locations provided in each report and actual location of the nearest OPFOR vehicle at the time the report was transmitted. The accuracy of Shell report locations was defined as the deviation between reported locations of OPFOR artillery impact and the actual impact locations. Location accuracy was calculated only for original reports, not relays, and deviations were based on the actual location of related OPFOR elements at the time each report was first transmitted. Only Contact, Spot and Shell reports with grid-based locations were treated as "scorable" for location accuracy. For the CVCC condition, report elements were directly entered into the DataLogger database files as CCD-based Contact, Spot and Shell reports were issued. Baseline report elements were obtained from audio playback tapes of each exercise and manually entered into DCA database files.

Nonparametric Mann-Whitney tests of differences between conditions were used for all measures under the collect threat information function due to the limited sample

Table 17

## Mean Performance for Selected Collect Threat Information Measures, by Echelon and Condition

Measures	Battalion		Company		Platoon	
	CVCC	Baseline	CVCC	Baseline	CVCC	Baseline
Accuracy of Contact report location (meters)	111.00 $\underline{n}=1$	167.00 $\underline{n}=1$	334.78 (421.46) $\underline{n}=6$	320.33 (510.09) $\underline{n}=6$	534.52 (808.25) $\underline{n}=15$	799.36 (883.13) $\underline{n}=7$
Accuracy of Spot report observed, location (meters)	2405.00 $\underline{n}=1$	NA	236.90 (398.05) $\underline{n}=10$	NA	76.43 (101.85) $\underline{n}=12$	1085.10 (1658.78) $\underline{n}=7$
Accuracy of Shell report location (meters) (221.32)	528.50 $\underline{n}=2$	1709.50 (494.74) $\underline{n}=1$	1180.00 (959.29) $\underline{n}=4$	1613.58 (982.36) $\underline{n}=6$	1820.83 $\underline{n}=12$	556.00 $\underline{n}=1$
Percentage of Contact reports with correct type	100.00% $\underline{n}=1$	50.00% (70.71) $\underline{n}=2$	62.50% (51.75) $\underline{n}=8$	71.43% (39.34) $\underline{n}=7$	76.47% (43.72) $\underline{n}=17$	80.95% (24.40) $\underline{n}=7$
Correctness of Spot report observed, number and type	100.00 $\underline{n}=1$	NA	69.42 (35.27) $\underline{n}=11$	NA	67.02 (28.22) $\underline{n}=12$	100.00 $\underline{n}=7$

Note. Standard deviations are in parentheses. NA indicates no data available for measure as defined and tested.

sizes (see Table 17). Across echelons, the mean location error of collected threat information by report type and condition is depicted in Figure 27. The mean location error for Contact reports, across echelons, was in the direction expected but not significant. For Spot reports, mean location error across echelons was in the direction expected and significant,  $\underline{U}(24, 7) = 40$ ,  $\underline{p} = .04$ ). For Shell reports, mean location error across echelons was neither in the direction expected or significant.

Percentage of Contact reports with correct enemy type was based on a comparison of reported enemy type with actual enemy types visible to commander at the time each report was issued. Only Contact reports with grid-based locations and designated enemy type were treated as "scorable" for percentage correct. Percentage of Contact reports with correct enemy type was 73.0% for CVCC participants and 72.9% for Baseline participants, a negligible difference in the direction expected.

The correctness of Spot report number by type was based on comparison of the number of enemy vehicles reported with the number of same-type vehicles visible to the reporting commander at the time the report was transmitted. When the number of vehicles visible equalled or exceeded the number reported, the report was scored as 100% correct; when the number of visible vehicles was less than the number reported,

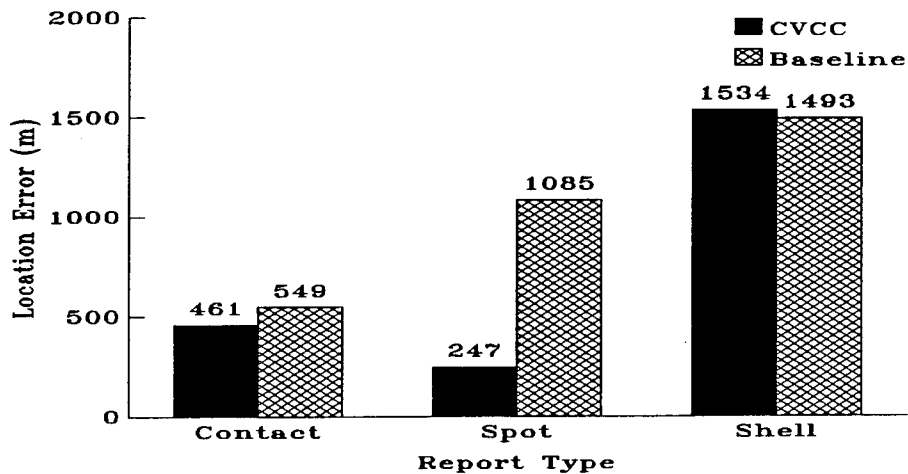

Figure 27. Mean accuracy of collect threat information reports based on reported locations, by report type and condition.

the number visible was divided by the number reported. Vehicle types included standard distinctions such as tank or personnel carrier as well as reported "observed" and "destroyed" vehicle status; separate correctness scores were calculated for each of these types.

The mean percentage for correctness of Spot reports across echelons on observed enemy vehicles was 69% for the CVCC condition and 100% for the Baseline condition. This difference was not in the direction expected and was significant,  $U(25, 7) = 24.5, p = .00$ ). The mean percentage for correctness of Spot reports across echelons on destroyed enemy vehicles was 72% for the CVCC condition and 74% for the Baseline condition, a negligible difference and not in the direction expected. Any conclusions of Baseline superiority on Spot report correctness should include consideration of the fact that Baseline participants issued significantly fewer scorable Spot reports than the CVCC condition.

Number of scorable Contact, Spot and Shell reports was a tally, by report type, of all reports that included grid locations on the enemy unit or activity reported. Overall mean number of scorable Contact, Spot and Shell reports per exercise by condition is depicted in Figure 28. For Contact reports, the mean number of scorable reports per exercise across echelons was 1.57 for the CVCC condition and .70 for the Baseline condition. This difference was in the direction expected and significant,  $U(112, 160) = 7,984, p = .01$ ). For Spot reports, the mean number of scorable reports per exercise across echelons was 1.64 for the CVCC condition and .35 for the Baseline condition. This difference was in the direction expected and significant,  $U(112, 160) = 7,512, p = .00$ ). For Shell reports, the mean number of scorable reports per exercise across echelons was 1.29 for the CVCC condition and .40 for the Baseline condition. This difference was also in the direction expected and significant,  $U(112, 160) = 7,968, p = .00$ ).

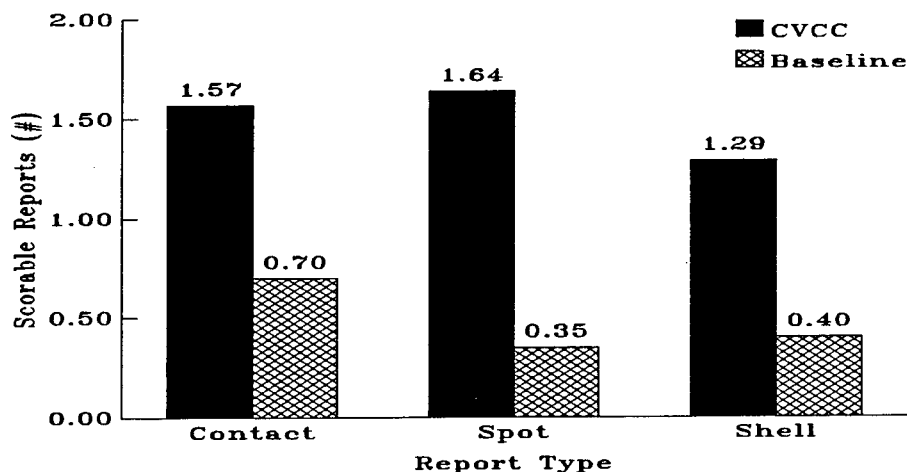

Figure 28. Mean number of scorable collect threat information reports per exercise based on location data, by report type and condition.

In discussion, CVCC-equipped participants demonstrated significantly improved performance over Baseline participants in their ability to collect and transmit more information on enemy units and activities as assessed under the Intelligence BOS. Differences between conditions on the accuracy of enemy locations and type were mixed and constrained by the fact that Baseline participants collected and transmitted few enemy reports that could be assessed for accuracy.

CVCC participants collected and transmitted significantly more accurate enemy location data in their Spot reports than Baseline participants. CVCC location accuracy in Spot reports was probably due to the ability to derive accurate enemy grid-based locations with the CCD's far-target designate feature based on lase inputs from the commander or gunner. In contrast, far-target designate is not applicable for determining the location of artillery impacts for Shell reports. Similarly, it may not be used as frequently during the preengagement phase when Contact reports are generally transmitted.

The potential for collecting and transmitting more accurate information on enemy locations, however, was firmly established by the Spot report data. The mean differences on Spot report accuracy in Figure 27 are compelling and somewhat mitigated by an outlier from the battalion echelon (see Table 17). Across the company and platoon echelons, mean Spot location error by CVCC participants was 149 meters. The importance of such accurate Spot report location information is hard to overstate. For battalion echelon commanders and staff, indirectly monitoring the situation, Spot reports provide the bottom-up data critical for visualizing the enemy situation.

Results on correct enemy type reported in Contact and Spot reports suggested the conditions were equivalent overall. The Baseline provided significantly more accurate enemy types on observed enemy vehicles but results were comparable in reports on type of enemy vehicles destroyed. No explanation for the Baseline's more accurate typing of enemy observed can be provided but it was based on a relatively few number of reports

collected exclusively at the platoon level. In general one might expect platoon-level commanders to be more accurate in identifying enemy types given their proximity.

Findings on number of scorable threat reports collected and transmitted clearly demonstrated the potential of digital C<sup>2</sup> systems for providing more complete and abundant data on enemy units and activities. The fact that CVCC participants collected and transmitted more information on enemy units and activities bolstered the expectation that digital systems may improve awareness of the enemy situation. In turn, the enemy information collected and transmitted by these reports was essentially the bottom-up information relayed under the previously considered C<sup>2</sup> BOS function, receive and transmit enemy information.

When results from collect and relay enemy information functions are combined, vertical integration in the CVCC battalion enabled commanders to share more accurate and abundant information on enemy units and activities. CVCC commanders had a more accurate knowledge of the enemy, in particular due to the Spot and INTEL reports collected and relayed. The significantly greater number of Contact, Spot and Shell reports collected and relayed supported the potential of digital C<sup>2</sup> systems to provide vertically integrated echelons more of the information on enemy location, type, size and activity that is critical to their visualization of the enemy situation.

### Conclusions

The findings indicated that vertically-linked digital C<sup>2</sup> systems provided significant advantages over voice-only communications for many of the critical battlefield functions tested under four Battlefield Operating Systems: Maneuver, Fire Support, Command and Control, and Intelligence. An overview of such findings across all BOS tested is provided in Table 18. In general, CVCC units excelled in executing the FRAGOs demanding maneuver and mission requirements, in acquiring and killing the threat at extended range, and in maintaining the high-tempo pace required by current doctrine and the future battlefield. CVCC commanders excelled in transmitting and receiving information on mission, threat and friendly troops that is critical to their visualization of battlespace.

Findings are subject to limitations of the MWTB, the method developed for this evaluation, and the set of measures as defined. Most MWTB limitations applied to both conditions and should not have contributed to differences reported. Transmission over the MWTB Ethernet, however, resulted in nearly "instantaneous" and perfectly consistent relay of CVCC reports and communications. Although the speed and reliability of digital communications is expected to significantly surpass that of voice-based systems, more realistic assessment of these factors and their impact on C<sup>2</sup> performance is required. Method limitations were described and included the need for more time per exercise, modification of the five minutes allotted for orientation to each exercise, the use of low visibility conditions, and the elimination of "swivel-chair" integration by the FSO. Limitations in measurement included the need for automated routines to detect misorientation and boundary violations, more precise indicators of target acquisition, and

Table 18

Significantly Improved CVCC Performance, by Battlefield Operating System (BOS)

---

1.0 Maneuver BOS

---

Reduced exposure to opposing force (OPFOR) in defensive withdrawal.  
Greater dispersion of manned platoon vehicles, < 100 meters apart.  
Greater dispersion of manned platoon vehicles, > 200 meters apart.  
More complete FRAGO execution, distance from scripted end-point of exercises.  
Less time spent at a halt by company and platoon echelons.  
More time moving velocity exceeded 40 km/hr.  
Less distance travelled by battalion command group.  
Less fuel used, despite more complete FRAGO execution.  
Faster lase times to multiple targets, based on minimal lase times.  
Extended acquisition range, based on maximum lase range.  
Greater hit range across battalion, company and platoon echelons.  
Greater kill range at company and platoon echelons.  
Greater number of rounds fired, commanders not fixated on tactical displays.

---

2.0 Fire Support BOS

---

Greater number of scorable CFFs, grid-based format.  
More CFFs with correct enemy type.

---

3.0 Command and Control BOS

---

Faster FRAGO relay to company, platoon and wingmen.  
Fewer requests to clarify FRAGO.  
Shorter duration of request to clarify FRAGO.  
More FRAGO elements correctly relayed by company and platoon.  
More Contact, Spot and Shell reports relayed.  
Fewer requests to clarify INTEL report.  
More INTEL report elements correctly relayed.  
Fewer voice communications between battalion echelon and TOC.  
More brief voice communications between battalion echelon and TOC.  
Fewer voice radio transmissions, across echelons.  
More brief voice radio transmissions, across echelons.  
Less voice net time on battalion, company and platoon nets.  
Fewer named voice reports on battalion, company and platoon nets.

---

4.0 Intelligence BOS

---

More accurate Spot report locations.  
More Contact, Spot and Shell scorable reports, grid-based formats

---

source accountability for all kills of the enemy. Future endeavors should attempt to overcome the limitations identified and to formulate more precise research hypotheses based on the empirical results obtained.

Vertical integration of digital C<sup>2</sup> systems across the battalion's echelons directly contributed to many of the significant findings reported. Findings on time halted and distance travelled, for example, provided a good example of CVCC's differential advantages across a vertically linked force. At the company and platoon level, the reduced halt time of CVCC participants bolstered the expectation that automated C<sup>2</sup> systems will help maintain the high-tempo pace required for the future battlefield. CVCC's battalion command group, on the other hand, travelled significantly less distance than their Baseline counterparts. The fact that CVCC equipped companies and platoons spent more time on the move and moved at an accelerated pace while their battalion command group travelled less distance, suggested that CVCC battalion-level commanders were able to monitor the execution of B Company from afar. Frequently, a conventionally equipped battalion commander can not directly monitor simultaneously his entire battalion due to the area covered, the concealment used and the locations obstructed by terrain. With vertically-linked digital C<sup>2</sup> systems the battalion commander can directly monitor the movement and formation of the battalion down to individual vehicles. The CVCC commanders' CCDs continuously updated the location of every battalion vehicle on their tactical display, relative to the FRAGO control measures governing mission execution.

Similarly, CVCC's extended lase range provides more effective and varied options for target processing in units with vertically-linked digital C<sup>2</sup> systems. With the CITV's far-target designation capability that automatically inputs grid locations into CCD-based enemy reports, commanders can rapidly and accurately request indirect fires to destroy or suppress the enemy or prevent disclosure of own location. Within the unit, and particularly in a defensive setting, far-target designate coupled with transmission of such reports provides a basis for the automated fire distribution and target designation capabilities anticipated in a digitally integrated force (Clark, 1993).

The impact of vertically linking a unit with digital C<sup>2</sup> systems was clearly evident in findings related to relay and clarify the mission. Baseline units experienced significant delays in FRAGO transmission at each echelon within an armor battalion. The evaluation's focus on vertical integration provided a unique opportunity to accrue the impact of such delays across an entire battalion-size unit. In the vertically linked CVCC battalion, commanders relayed and received more of the information on enemy location, type, size and activity that is critical to their awareness of the enemy situation. Findings on receive and transmit friendly troop information evidenced the potential of digital C<sup>2</sup> systems, relative to voice-based radio, to improve performance on this essential C<sup>2</sup> function and enable the commander to better visualize the friendly situation. Vertical integration of digital C<sup>2</sup> systems within the CVCC battalion precluded the need for many of the conventional reports on friendly unit location, status and progress. Vertically-linked digital C<sup>2</sup> systems provided the automatic relay of this information to the

battalion's command group and staff and drastically reduced their requirement to share and coordinate friendly and related information through voice communications.

In summary, the findings support the Army's requirement to forge a digitally integrated force and vertically link the echelons within a unit to increase operational effectiveness and C<sup>2</sup> potential. The findings provide soldier-in-the-loop data to Army developers of doctrine, materiel and training for digital C<sup>2</sup> systems. The method used provides an example of how simulation-based technologies can meet C<sup>2</sup> training and evaluation requirements.

## REFERENCES

- Alluisi, E. A. (1991). The development of technology for collective training: SIMNET, a case history. Human Factors, 33, 343-362.
- Atwood, N. K., Wunsch, B. J., Quinkert, K. A., & Heiden, C. K. (1994). Catalog of training tools for use in distributed interactive simulation (DIS) environments (ARI Research Product 94-11). Alexandria, VA: U.S. Army Research Institute for the Behavioral and Social Sciences. (AD A282 841)
- Atwood, N. K., Wunsch, B. J., Sawyer, A. R., Ford, L. A., & Quinkert, K. A. (1994). Training and soldier-machine interface for the combat vehicle command and control system (ARI Technical Report 1007). Alexandria, VA: U.S. Army Research Institute for the Behavioral and Social Sciences. (AD A285 677)
- BBN Systems and Technologies Corp. (1991). SIMNET-D data collection and analysis system. Cambridge, MA: Bolt, Beranek, and Newman Systems and Technologies Corp.
- Blasche, T. R., & Lickteig, C. W. (1984). Utilization of a vehicle integrated intelligence (V(INT)<sup>2</sup>) system in armor units (ARI Research Report 1374). Alexandria, VA: U.S. Army Research Institute for the Behavioral and Social Sciences. (AD A168 828)
- Burkett, J. (1991, November). Tactical information: What you see is what you get. Military Review, pp. 39-44.
- Clark, W. K. (1993, November). Digitization: Key to landpower dominance. Army, pp. 28-33.
- Chung, J. W., Dickens, A. R., O'Toole, B. P., & Chiang, C. J. (1987). SIMNET M1 Abrams main battle tank simulation: Software description and documentation (Revision 1) (BBN Report 6323). Cambridge, MA: Bolt, Beranek, and Newman Systems and Technologies Corp.
- DePuy, W. E. (1988). Concepts of operation: The heart of command, the tool of doctrine. Army, pp. 26-28.
- Du Bois, R. S., & Smith, P. G. (1991). Simulation-based assessment of automated command, control, and communications for armour crews and platoons: The intervehicular information system (IVIS) (ARI Technical Report 918). Alexandria, VA: U.S. Army Research Institute for the Behavioral and Social Sciences. (AD A233 509)

- Du Bois, R. S., & Smith, P. G. (1989). A simulation-based evaluation of a position navigation system for armor: Soldier performance, training, and functional requirements (ARI Technical Report 834). Alexandria, VA: U.S. Army Research Institute for the Behavioral and Social Sciences. (AD A210 696)
- Elliott, G., S., & Quinkert, K. A. (1993). Performance measures for simulation (ARI Research Product 93-08). Alexandria, VA: U.S. Army Research Institute for the Behavioral and Social Sciences. (AD A267 837)
- Foley, T. C. (1992). The future battlefield. Armor, 101(2), 4.
- Foss, J. W. (1991, February). Advent of the nonlinear battlefield: AirLand battle-future. Army, pp. 20-37.
- Franks, F. M. (1994). The Way Ahead—Post AWE 94-07. Unpublished manuscript.
- Funk, P. E. (1994, February). The army's "digital revolution." Army, p. 33.
- Giboney, T. B. (1991, November). Commander's control from information chaos. Military Review, pp. 34-38.
- Goldstein, I. L. (1991). Training in work organizations. In M. D. Dunnette, & L. M. Hough (Eds.), Handbook of Industrial and Organizational Psychology (Vol. 2, Chapter 9, pp. 507-619). Palo Alto, CA: Consulting Psychologists Press, Inc.
- Goodman, G. W. (1993, May). U.S. Army synchronizes its combat arms with digital data. Armed Forces Journal International, pp. 35-36.
- Greess, M. (1994). The combat vehicle command and control system architecture overview (ARI Research Product 95-05). Alexandria, VA: U.S. Army Research Institute for the Behavioral and Social Sciences. (AD A286 259)
- LaVine, N. D., Lickteig, C. W., & Schmidt, J. H. (1993). Description of a tank-based automated command and control system as simulated for the combat vehicle command and control program (ARI Research Product 93-02). Alexandria, VA: U.S. Army Research Institute for the Behavioral and Social Sciences. (AD A263 459)
- Leibrecht, B. C., Meade, G. A., Schmidt, J. H., Doherty, W. J., & Lickteig, C. W. (1994). Evaluation of the combat vehicle command and control system: Operational effectiveness of an armor battalion (ARI Technical Report 998). Alexandria, VA: U.S. Army Research Institute for the Behavioral and Social Sciences. (AD A282 767)

- Leibrecht, B. C., Kerins, J. W., Ainslie, F. M., Sawyer, A. R., Childs, J. M., & Doherty, W. J. (1992). Combat vehicle command and control systems: I. Simulation-based company level evaluation (ARI Technical Report 950). Alexandria, VA: U.S. Army Research Institute for the Behavioral and Social Sciences. (AD A251 917)
- Leibrecht, B. C., Wunsch, B. J., Ford, L. A., Sawyer, A. R., Meade, G. A., Ainslie, F. M., Smith, P. G., Sever, R. S., & Doherty, W. J. (1993). Battalion evaluation of the combat vehicle command and control system in distributed interactive simulation: Preliminary findings (ARI Technical Report 992). Alexandria, VA: U.S. Army Research Institute for the Behavioral and Social Sciences. (AD A275 912)
- Lickteig, C. W. (1988). Design guidelines and functional specifications for simulation of the battlefield management system's (BMS) User Interface (ARI Research Product 88-19). Alexandria, VA: U.S. Army Research Institute for the Behavioral and Social Sciences. (AD A201 189)
- Lickteig, C. W., & Emery, C. D. (1994). Information management performance of future platoon leaders: An initial investigation (ARI Technical Report 1000). Alexandria, VA: U.S. Army Research Institute for the Behavioral and Social Sciences. (AD A282 908)
- Lickteig, C. W., Williams, S. G., & Smart, D. L. (1992). Vertical slice battalion-level assessment of future command and control systems. Paper presented at the 34th Annual Conference of the Military Testing Association, San Diego, CA.
- Meade, G. A., Lozicki, R. J., Leibrecht, B. C., Smith, P. G., & Myers, W. (1994). The combat vehicle command and control system: Combat performance of armor battalions using interactive simulation (ARI Research Report 1661). Alexandria, VA: U.S. Army Research Institute for the Behavioral and Social Sciences. (AD A282 112)
- Miller, D. C., & Chung, J. W. (1987). SIMNET-D capabilities and overview. Cambridge, MA: Bolt, Beranek, and Newman Laboratories.
- O'Brien, L. H., Wigginton, D., Morey, J. C., Leibrecht, B. C., Ainslie, F. M., & Sawyer, A. R. (1992a). Combat vehicle command and control battalion-level preliminary evaluation (ARI Research Report 1627). Alexandria, VA: U.S. Army Research Institute for the Behavioral and Social Sciences. (AD A257 467)

- O'Brien, L. H., Wigginton, D., Morey, J. C., Leibrecht, B. C., Ainslie, F. M., & Sawyer, A. R. (1992b). Data tables from combat vehicle command and control battalion-level preliminary evaluation (ARI Research Note 92-84). Alexandria, VA: U.S. Army Research Institute for the Behavioral and Social Sciences. (AD A258 580).
- Phelps, R. O., & Kupets, G. (1984). U.S. Army Human Engineering Laboratory Communications Survey—A pilot study (HELCOMS-PS) (Technical Notes 14-84). Aberdeen Proving Ground, MD: U.S. Army Human Engineering Laboratory.
- Pope, A. R. (1987). The SIMNET network and protocol (BBN Report 6309). Cambridge, MA: Bolt, Beranek and Newman Laboratories.
- Quinkert, K. A. (1990). Crew performance associated with the simulation of the Commander's Independent Thermal Viewer (CITV) (ARI Technical Report 900). Alexandria, VA: U.S. Army Research Institute for the Behavioral and Social Sciences. (AD A226 890)
- Ross, J. D. (1994, February). Winning the information war. Army, pp. 26-32.
- Sever, R. S., & Heiden, C. K. (in preparation). Battalion tactical operations center (TOC) job aid (ARI Research Product). Alexandria, VA: U.S. Army Research Institute for the Behavioral and Social Sciences.
- Siegel, S. (1956). Nonparametric statistics for the behavioral sciences. New York, NY: McGraw-Hill.
- SPSS Inc. (1988). SPSS/PC+ V2.0 for the IBM PC/XT/AT and PS/2. Chicago, IL: SPSS Inc.
- Sullivan, G. R. (1994). Digitizing for a 21st Century Force. Speech delivered to Association of the U.S. Army Institute for Land Warfare in Pentagon City, VA: Speech File Service.
- U.S. Army Armor Center (1994, July). Advanced warfighting experiment: Operation Desert Hammer VI. Fort Knox, KY. (Available from the Commander, U.S. Army Armor Center and Fort Knox, ATTN: ATZK-PTF-D, Fort Knox, KY 40121-5200.)
- U.S. Army Armor Center. (1992, June). IVIS operational concept. Fort Knox, KY. (Available from the Commander, U.S. Army Armor Center and Fort Knox, ATTN: ATZK-CDD, Fort Knox, KY 40121-5215.)

- U.S. Army Armor Center (1988). Intervehicular information system (IVIS) starter package requirements (ATSB-CD). Fort Knox, KY: U.S. Army Armor Center, Directorate of Combat Developments.
- U.S. Army Armor School. (1987, March). M1 SIMNET operator's guide. Fort Knox, KY. (Available from the Commander, U.S. Army Armor Center and Fort Knox, ATTN: ATZK-PTF-D, Fort Knox, KY 40121-5200.)
- U.S. Army Training and Doctrine Command (1991, May). Blueprint of the battlefield (TRADOC Pam 11-9, Final Draft). Fort Monroe, VA. (Available from the Commander, U.S. Army Training and Doctrine Command, ATTN: ATDO-P, Fort Monroe, VA 23651-5000.)
- U.S. Department of the Army (1994, January-February). Training on the digitized battlefield. Armor, pp. 37-39.
- U.S. Department of the Army (1993a, June). Operations (FM 100-5). Washington, DC. (Available from the Commander, U.S. Army Training and Doctrine Command, ATTN: ATDO-P, Fort Monroe, VA 23651-5000.)
- U.S. Department of the Army (1993b, September). Army Focus 93: Moving Out to the 21st Century. Washington, DC.
- U.S. Department of the Army (1985). Battalion and brigade command and control (Field Circular 71-6). Fort Knox, KY: U.S. Army Armor Center.
- Wunsch, B. J., Atwood, N. K., Sawyer, A. R., Heiden, C. K., Smith, P. G., & Schwartz, B. (1994). Innovative training concepts for use in distributed interactive simulation environments (ARI Research Product 94-16). Alexandria, VA: U.S. Army Research Institute for the Behavioral and Social Sciences. (AD A285 585)

**Appendix A**  
**Event Lists for Training and Test Events**

EVENT LIST FOR TRAINING EXERCISE A: MOVE TO REINFORCE UNIT

NO	TIME (min)	STIMULUS	BLUEFOR
1.	SETUP	General Briefing/Orientation (O_OriA). Presented in classroom prior to mounting simulators.	A Co ES772923 B Co ES780925 C Co ES771912 D Co ES781911 Bn Cmd Grp ES777919 TOC ES780914 HOW BTY ES822892 dir 3200
2.	T+00:00		Bn is located in TAA HAWK. Enemy has been stopped at PL JIM. Bn reports REDCON1.
3.	T+00:15	Movement order is ready.	TOC issues movement order. a. Baseline Oral (O_B_MovA) b. CVCC: Digital overlay with text (tng-a-ol) and Oral (O_C_MovA).
4.	T+08:00		A Co reports 1 vehicle bent; contact team on site.
5.	T+10:00	B Co reports REDCON1.	Bn Cdr orders B Co to execute.
6.	T+12:00	B Co crosses SP.	B Co reports SP.
7.	T+15:00	1st Plt/B Co encounters mech inf plt moving N on road between SP and CPI.	1st Plt sends Spot or Intel report. Co Cdr relays.

NO	TIME (min)	STIMULUS	BLUEFOR
----	------------	----------	---------

- |     |         |   |   |
|-----|---------|---|---|
| 8.  | T+15:30 | 1-91 IN reports sporadic enemy contact, less than plt size, to their South; in addition, remnants of friendly units have been sighted moving back to the North in sector. | TOC relays report on Bn Cmd net.                          |
| 9.  | T+16:00 | 1st Plt/B Co encounters ADA plt vic ES806912.   | 1st Plt sends Spot or INTEL report. Co Cdr relays report. |
| 10. | T+19:00 | 1st Plt/B Co encounters Howitzer Bty in position vic ES822892.  | 1st Plt sends Spot or INTEL report. Co Cdr relays report. |
| 12. | T+20:00 | 1st Plt crosses CP4.  | 1st Plt reports CP4. Co Cdr relays report.                |
| 13. | T+21:00 |   | D Co sends ammo status: HEAT AMBER.                       |
| 14. | T+23:00 | 1st Plt crosses CP6.  | A Co sends ammo status: SABOT AMBER.                      |
| 15. | T+35:00 | Event terminated when B Co clears the RP or T+35:00.  | 1st Plt reports CP6. Co Cdr relays report.                |

EVENT LIST FOR TRAINING EXERCISE B: BYPASS ENEMY/GUARD

NO	TIME (min)	STIMULUS	BLUEFOR
----	------------	----------	---------

1.	SETUP	General Briefing/Orientation (O_ OriB) En BMP Plt ES749929 En MRB ES720926	A Co ES779936 B Co ES764964 C Co ES787951 D Co ES782980 Scouts ES763900 Bn Cmd Grp ES794957 Mort Plt ES771971 TOC ES825985 How Bty 1 ES804954 How Bty 2 ES796955 How Bty 3 ES788959
----	-------	--	---

1. T+00:00 Units acknowledge orientation. Battlemaster sets execution time and informs the Command group on the Bde Cmd net.

2. T+5:00 Battlemaster directs Bn to begin moving.  
En BMP Plt, ES749929, engages B Co with 30mm cannon and AT-4. Fire is ineffective and low intensity.

- a. Tanks come on line
- b. Orient toward enemy
- c. Move to hull down
- d. Return fire
- \* e. Report contact.

B Co Cdr directs bypass, informs Bde.

\* PVD Operator Flag

NO	TIME (min)	STIMULUS	BLUEFOR
----	------------	----------	---------

- |    |        |  |  |
|----|--------|--|--|
| 4. | T+5:30 | Message to Y02 from N02 [Bde O&I] Approx 30 BMPs, ES720926. Stationary, appear to be reorganizing. (Baseline only)   |  |
| 5. | T+6:00 | CVCC: SEND message file "D_C_IntB" on 1/Bn network, upon contact.  | Baseline: Y02 passes report (O_B_IntB) on Bn Cmd net.                |
| 6. | T+6:30 | Message to Y06 from N06 [Bde Cmd]: "Adjacent unit will attack that MRB on your right in about fifteen to twenty minutes. Guard your flank, but keep moving: I want you to across JIM within 25 minutes." |  |
| 7. | T+7:00 | Baseline: send hard-copy script (O_B_WngB) to Bn Cdr.<br>CVCC: Cue SEND message D_C_WngB on 1/Bn network, coordinate with TOC and execute when TOC transmits voice alert.                                | Baseline: Bn Cdr sends warning order.<br>CVCC: TOC sends "O_C_WngB." |
| 8. | T+8:00 | Co C reports one vehicle bent; BMO enroute to evaluate.  |  |
| 9. | T+9:00 | Message to Y06 from S11: Negative contact; blitzing to screen right flank.<br><br>Direct TOC to issue FRAGO overlay in 60 seconds.   |  |

NO	TIME (min)	STIMULUS	BLUEFOR
10.	T+10:00		<p>TOC issues FRAGO.</p> <p>a. Baseline: Oral (O_B_FRGB)</p> <p>b. CVCC: Digital overlay with text (anxAfrgB and oral alert (O_C_FRGB)).</p>
11.	T+12:00	OPFOR operator drops sporadic artillery barrage at ES780910.	Co A reports observing artillery vicinity ES780910.
12.	T+15:00	Units report REDCON 1.	Bn Cdr executes FRAGO. B Co & scouts move to Bn right flank and assume guard mission.
13.	T+20:00	OPFOR operator drops sporadic artillery barrage at ES775908.	<p>Remainder of Bn continues mission.</p> <p>B Co keeps abreast of main body; occupies BPs 21-24 as required.</p>
14.	T+22:00	<p>En Plt (- losses) withdraws to West when B Co begins assault.</p> <p>En MRB does not fire on B Co unless fired upon. When B Co has established LOS, MRB (-) begins moving to defensive positions NW of its AA.</p> <p>CVCC: Send message file "D_C_FrB1" on 1/Bn network.</p>	<p>A Co reports observing artillery, continuing mission.</p> <p>Baseline: TOC relays message.</p>

NO	TIME (min)	STIMULUS	BLUEFOR
----	------------	----------	---------

- |     |         |   |   |
|-----|---------|---|---|
| 15. | T+27:00 | BMO reports C Co veh up; will rejoin unit at OBJ STEEL.   |   |
| 16. | T+30:00 |   | Baseline: C Co reports ammo status: SABOT: AMBER. |
| 17. | T+31:00 | Bde relays report that 25 AD has begun hasty attack on MRB position.  | TOC relays report to B Co.                        |
| 18. | T+32:00 |   | Co D reports status: no change.                   |
|     |         |   | Co A reports PL JIM.                              |
| 19. | T+33:00 | 1-91 IN reports PL JIM, continuing mission.   | TOC relays report.                                |
| 20. | T+35:00 | Event terminated at T+35:00 or when B Co crosses PL JIM.<br>Transmit on Bn Cmd , 1st Plt and Bn O&I nets: "CEASE FIRE/Freeze." Direct all crews to shutdown and dismount simulators, and report to stealth position ASAP. |   |

EVENT LIST FOR TEST EVENT 1: ASSAULT

NO	TIME (min)	STIMULUS	BLUEFOR
----	------------	----------	---------

1.	SETUP	General Briefing/Orientation (O_ Ori) En MRC + ES749880-ES750879	A Co ES773911 B Co ES766923 C Co ES783918 D Co ES776929 Scouts ES764900 Bn Cmd Grp ES773915 Mort Plt ES779918 dir 3800 TOC ES825985 How Bty 1 ES804954 How Bty 2 ES796955 How Bty 3 ES788959
----	-------	---	--

2.	T+00:00	Units acknowledge orientation.	Bn is conducting a movement to contact. The Bn is in a diamond formation with A Co leading. OPORD directs the Bn to bypass enemy units smaller than company size.
----	---------	--------------------------------	---

3.	T+05:00	Battlemaster directs Bn to begin moving.  ** Baseline: Message to Y02 from N02 [BDE O&I]: Enemy reinforced MRC vic ES748879: stationary, appears to be preparing defensive positions. CVCC: Send message file D_C_Int1	Bn Cdr directs mission execution.  Baseline: Y02 passes intel report (O_B_Int1) on Bn Cmd net.
----	---------	---	--

\* PVD Operator Flag  
\*\* Battlemaster Flag

NO	TIME (min)	STIMULUS	BLUEFOR
----	------------	----------	---------

A Co assumes a position along ridge line from ES757908-770901 and halts, reports halted N of CP12, observing enemy activity.

- |    |         |   |  |
|----|---------|---|--|
| 4. | T+05:30 |   |  |
| 5. | T+05:45 | Message to Y06 from N06 [BDE CMD]: Execute a hasty attack to clear the enemy position vic CP9.  |  |
| 6. | T+06:00 | Baseline: send hard-copy script (O_B_Wng1) to Bn Cdr.<br>CVCC: Cue SEND message D_C_Wng1 on 1/Bn network, coordinate with TOC and execute when TOC transmits voice alert. | Baseline: Bn Cdr sends warning order for a hasty attack, directs TOC to generate FRAGO.<br>CVCC: TOC sends voice message "O_C_Wng1." |
| 7. | T+07:00 |   | Scouts request instructions; Bn Cdr directs scouts to move to screen right flank.  |
| 8. | T+10:00 |   | ** TOC issues FRAGO.<br>a. Baseline: Oral (O_B_Frg1)<br>b. CVCC: Digital overlay with text (anxAfrg1) and Oral alert (O_C_Frg1).     |
| 9. | T+12:00 | Units report REDCON 1.  | Bn Cdr executes mission. A and C move to support by fire, B leads D on AXIS Green.   |

\* PVD Operator Flag  
\*\* Battlemaster Flag

NO	TIME (min)	STIMULUS	BLUEFOR
----	------------	----------	---------

10. T+15:00 Enemy engages with indirect and direct fire when within sight and range. Tank crews send Contact and Spot reports through chain of command.

**NOTE: OPFOR indirect fires implemented by bomb button, one 8-round sheaf every 15 seconds on targets of opportunity.**  
A and C send Contact, Spot, and Shellreps.

11. T+18:00 Baseline: Voice radio message from J06 to N06: "Have moderate contact vic ES875870; En Co(-) in hasty defenses, executing hasty attack."  
CVCC: SEND message file D\_C\_Frg1 on 1/Bn net. Baseline: TOC relays report.  
A and C report ammo status.

12. T+25:00 \* \*\* Event terminated when B Co crosses FCL or at T+25:00.

**NOTE: If breaking for lunch, ensure DataLogger is shut down and operator is aware of anticipated restart time. Measurements of 1st Plt vehicle distances from Final CL (if event runs to time limit) are taken from the RJ at ES714885.**

\* PVD Operator Flag  
\*\* Battlemaster Flag

EVENT LIST FOR TEST EXERCISE 2: FLANK ATTACK

NO	TIME (min)	STIMULUS	BLUEFOR
----	------------	----------	---------

- |    |         |  |  |
|----|---------|--|--|
| 1. | SETUP   | General Briefing/Orientation (O_Oriz)<br>3 BMPs ES755828<br>2 T80s ES755833<br>En BMP Plts vic OBJs BRONZE and ZINC. | A Co ES775866<br>B Co ES761873<br>C Co ES788873<br>D Co ES772878<br>Scouts ES741882<br>Cmd Grp ES776868<br>Mort Plt ES772870 dir 3000<br>TOC ES825985<br>How Bty 1 ES778898<br>How Bty 2 ES757884<br>How Bty 3 begins to move from previous position to ES786875 at T+00:00. |
| 2. | T+00:00 | Units acknowledge orientation.   | Bn is conducting attack on OBJ STEEL. Cos are approaching their individual objectives (TIN, BRONZE, and ZINC).   |
| 3. | T+05:00 | ** Battlemaster directs Bn to begin moving.  | Bn Cdr executes mission.   |
| 4. | T+07:00 | En BMPs and T-80s open fire when in range.   | B Co executes action drill: <ul style="list-style-type: none"> <li>a. Tanks come on line</li> <li>b. Orient toward enemy</li> <li>c. Move to hull down</li> <li>d. Return fire</li> <li>e. Report contact</li> </ul>   |

\* PVD Operator Flag

\*\* Battlemaster Flag

NO	TIME (min)	STIMULUS	BLUEFOR
----	------------	----------	---------

- |     |         |  |   |
|-----|---------|--|---|
| 5.  | T+09:00 | OPFOR operator begins sporadic artillery barrage vic known contacts.<br><br>Send hard-copy Oral FRAGO script (Baseline: O_B_Frg2, CVCC: O_C_Frg2) to Bn Cdr.   | A and C Cos send SHELLREPs.<br><br>** Bn Cdr issues FRAGO.  |
| 6.  | T+11:00 | B Co reports executing FRAGO.  | B Co assaults enemy position, followed by D Co, then proceeds to OBJ TIN. A and C Cos continue mission.                                     |
| 7.  | T+12:00 | Digital FRAGO complete.  | TOC sends digital FRAGO w/ overlay (D_C_Frg2).  |
| 8.  | T+13:00 | Voice message from J33 to N33: "Crossing PL BOB, continuing mission."  | TOC relays report.<br><br>A and C COs send Contact and Spot Reports, report progress.   |
| 9.  | T+16:00 | Voice message from J06 to N06: "Contact vic OBJ IRON: attacking."  | TOC relays message.   |
| 10. | T+22:00 | Baseline: Voice message from J33 to N33: "OBJ IRON seized. Overran estimated MRC(+) in hasty defenses. Consolidating OBJ."<br>CVCC" Send Message file D_C_Frg2 | TOC relays message.<br><br>C Co reports OBJ ZINC seized; sends current status.<br><br>A Co reports OBJ BRONZE seized; sends current status. |

\* PVD Operator Flag  
\*\* Battlemaster Flag

NO	TIME (min)	STIMULUS	BLUEFOR
----	------------	----------	---------

11. T+24:00 D Co reports light contact with En dismounted soldiers; taking prisoners.

12. T+25:00 \* \*\* Event terminated when B Co seizes TIN or at T+25:00.

**NOTE: If breaking for lunch, ensure DataLogger is shut down and operator is aware of anticipated restart time. Measurements of 1st Plt vehicle distances from OBJ BRONZE (if event runs to time limit).**

\* PVD Operator Flag  
 \*\* Battlemaster Flag

EVENT LIST FOR TEST EXERCISE 3: ABORTED ATTACK

NO	TIME (min)	STIMULUS	BLUEFOR
----	------------	----------	---------

- |    |       |   |   |
|----|-------|---|---|
| 1. | SETUP | <p>General Briefing/Orientation (O_ Ori3)</p> <p>En MRC+ ES827724</p> <p>En MRC+ ES843727</p> <p>En MRC+ ES857744</p> | <p>A Co ES818766</p> <p>B Co ES806763</p> <p>C Co ES835774</p> <p>D Co ES816780</p> <p>Scouts ES790760</p> <p>Bn Cmd Grp ES817774</p> <p>Mort Plt ES826769 dir 3000</p> <p>TOC ES789832</p> <p>How Bty 1 ES783786</p> <p>How Bty 2 ES825803</p> <p>How Bty 3 ES806797</p> |
|----|-------|---|---|

- |    |         |                                |  |
|----|---------|--------------------------------|--|
| 2. | T+00:00 | Units acknowledge orientation. | Bn is halted behind PL CARL waiting for arty prep to lift. Cos A, B, and C are on line, prepared to attack OBJ CARL. |
|----|---------|--------------------------------|--|

- |    |         |   |   |
|----|---------|---|---|
| 3. | T+05:00 | <p>Battlemaster directs Bn to execute attack at (T+10).</p> <p>** Baseline: Message to Y02 from N02 [BDE O&amp;I]: "Estimated three MRCs, reinforced with tanks , dug-in at ES827724, ES843727 and ES857744."</p> <p>CVCC: Direct S2 to copy overlay "D_C_Int3" and transmit to Bn.</p> | <p>Bn Cdr orders arty prep to commence. BLUEFOR arty prep on OBJ COPPER begins.</p> <p>Baseline: Y02 relays report (O_B_Int3) to Bn.</p> <p>CVCC: Y02 relays overlay to Bn.</p> |
|----|---------|---|---|

\* PVD Operator Flag  
 \*\* Battlemaster Flag

NO	TIME (min)	STIMULUS	BLUEFOR
4.	T+06:00	Baseline: Message to Y02 from N02 [BDE O&I]: "X21 reports 15 BMPs and 6 T-80s dug in on COPPER." CVCC: Send message file, D_C_AC3 on 1/Bn net.	Baseline: Y02 relays report (O_B_AC3) to Bn.
5.	T+10:00	BLUFOR prep lifts.  Heavy OPFOR artillery falls on lead Cos.  OPFOR opens up with accurate direct fire when BLUFOR comes within range.	* Bn Cdr executes attack; Cos cross PL CARL.  Units send SHELLREPs.  Units send Contact and Spot reports up chain of command. A and C Cos slow, begin fire and movement by Plts. Report contacts, spots, and progress.
6.	T+12:00	Voice message from J33 to N33: "We are in heavy contact north of OBJ BRASS."  When B Co advances to stream vic ES806746, OPFOR launches HINDS.	
7.	T+15:00	Lead Cos sustain 20-30% casualties.  Send hard-copy Oral FRAGO script (Baseline: O_B_Frg3, CVCC: O_C_Frg3), with appropriate section crossed out, to Bn Cdr.	Bn Cdr stops attack and orders withdrawal to PL CARL.  Units report contacts and status changes.

\* PVD Operator Flag

\*\* Battlemaster Flag

NO	TIME	STIMULUS	BLUEFOR
----	------	----------	---------

**NOTE: If OPFOR is unable to rapidly inflict sufficient casualties, Transmit: "Y06 this is N06, Juliet has met heavy enemy resistance on BRASS and is withdrawing to CARL. Papa cannot support. Your left flank is exposed. Withdraw to CARL NOW, and establish a hasty defense."**

- |     |         |   |   |
|-----|---------|---|---|
| 8.  | T+17:00 | (If not already accomplished) 1-91 IN reports withdrawal to PL CARL.                  |   |
| 9.  | T+18:00 | Digital FRAGO complete.   | <p>TOC sends digital FRAGO overlay (anxAfrg3)</p> <p>Units report contacts/status.</p> <p>* Units report crossing PL CARL.</p>  |
| 10. | T+20:00 | En BMPs and T-80s pursue BLUFOR back to PL CARL.                                      | <p>Cos use fire and maneuver to cover movement of Plts to PL CARL.</p> <p>Cos request FASCAM and smoke to cover withdrawal.</p> |
| 11. | T+25:00 | * ** Event is terminated when manned Plt crosses PL CARL in retrograde or at T+25:00. |   |

\* PVD Operator Flag  
 \*\* Battlemaster Flag

EVENT LIST FOR TEST EXERCISE 4: WITHDRAW

NO	TIME (min)	STIMULUS	BLUEFOR
----	------------	----------	---------

- |    |       |   |  |
|----|-------|---|--|
| 1. | SETUP | <p>General Briefing/Orientation<br/>                     Baseline: (O_B_Ori4)<br/>                     CVCC: (O_C_Ori4)</p> <p>En MRB+ ES835665<br/>                     En MRB+ ES862683<br/>                     En MRB+ ES850595<br/>                     En MRB+ ES896610<br/>                     How Bty 2 ES840683 dir 6000<br/>                     How Bty 3 ES812673 dir 6200</p> | <p>A Co ES816776<br/>                     B Co ES784759<br/>                     C Co ES841766<br/>                     D Co ES792812<br/>                     Scouts ES770740-816745<br/>                     Bn Cmd Grp ES804780<br/>                     Mort Plt ES819771<br/>                     TOC ES789832<br/>                     How Bty 1 ES781834 dir 2800</p> |
|----|-------|---|--|

CVCC only: Send message file D\_C\_Wng4 on 1/Bn Net, and transmit Intel Overlay (D\_C\_Int4) on Bn net during briefing.

- |    |         |   |   |
|----|---------|---|---|
| 2. | T+00:00 | ** Units acknowledge orientation. Two MRBs are poised for attack south of PL CARL. OPFOR begins movement. | Bn is to withdraw from hasty defense vic PL CARL. |
|----|---------|---|---|

- |    |         |                    |  |
|----|---------|--------------------|--|
| 3. | T+05:00 | ** FRAGO complete. | <p>TOC issues FRAGO.</p> <p>a. Baseline: Oral (O_B_Frg4)<br/>                     b. CVCC: Digital w/ overlay (D_C_Frg4) and Oral (O_C_Frg4)</p> |
|----|---------|--------------------|--|

\* PVD Operator Flag  
 \*\* Battlemaster Flag

NO	TIME (min)	STIMULUS	BLUEFOR
----	------------	----------	---------

4. T+10:00 Two MRBs cross OPFOR PL PRAVDA. Enemy artillery prep begins. \* Bn Cdr executes FRAGO. Bn(-) begins withdrawal.

Voice message: "November, this is N06." (ECR member responds for J06. Await Y06 response.) "Execute withdrawal as soon as you are ready. Report when moving. Detachment Left in Contact sends Contact, Spot, and Shell reports through chain of command. Units report SP, CPs, and RP.

5. T+12:00 Message to N06 from J06: "Enemy pressure in sector increasing; executing withdrawal now."

6. T+15:00 Enemy continues arty prep, engages with direct fires when within sight and range.

Detachments Left In Contact (DLICs) cover withdrawal of main body, displace to avoid being overrun.

DLICs report Contact, Ammo, and Sitrep reports.

7. T+17:00 Message from J33 to N33: "DLIC reports withdrawing now."

8. T+29:00 1-91 IN (J33) reports PL JIM; begins passage of lines.

9. T+35:00 \* \*\* Event terminated when manned plt crosses PL BOB or at T+35:00.

\* PVD Operator Flag

\*\* Battlemaster Flag

## APPENDIX B

### Operations Order's (OPORD's) Scripted Presentation

#### Oral Bn OPORD 300 Script For CVCC and Baseline Conditions

(TO BE READ VERBATIM)

#### 1. Situation

##### a. Enemy Forces

1. (Show Intel Overlay slide) After a successful attack to the north, the 39th Guards Motorized Rifle Division has established a hasty defense in the vicinity of the ES 92 east-west gridline. The 144th Motorized Rifle Regiment, a first echelon regiment of the 39th, was leading the attack in the 1-10 AR sector prior to this halt. Enemy contact has been lost throughout the Bde sector.
2. (Show composition slide) The 144th MRR consists of 3 motorized rifle battalions and 1 tank battalion. However, the tank battalion has been split to provide a tank company to each of the 3 motorized rifle battalions. The 144th MRR, equipped with T-80s and BMP-2s, is estimated to be at 40-50% strength.
3. (Show Intel Overlay slide) Most units of the 144th have withdrawn and are establishing an east-west defensive belt in the vicinity of Elizabethtown. A rear guard consisting of a battalion (+) size element will probably be delaying to the south. Disorganized platoon-sized units may be encountered throughout our zone.

##### b. Friendly Forces. (Show Operations Overlay slide)

1. 1st Bde, 23d Armored Division conducts a Movement to Contact to seize OBJs COPPER and BRASS.
2. 1-91 Mech, on our left, will seize OBJ BRASS. On our right, the 25th Armored Division conducts a movement to contact parallel to our own division. To our rear, TF 3-4 AR from the 52d ID, will prepare defensive positions along PL NASH. 4-4 AR will follow our battalion as Brigade Reserve.

#### 2. Mission

1-10 AR, as the Brigade Main Effort, conducts a Movement to Contact at 280500R Sep 04 to seize intermediate OBJs BRONZE, TIN, AND ZINC. On order, continues south to seize OBJ COPPER.

### 3. Execution

- a. My concept is to move rapidly, bypassing units smaller than company size if they pose no threat to our advance. Flank and following companies may be required to fix or isolate these small enemy units until the 4-4 AR, following us, can destroy them. I don't expect much resistance, but the situation is very fluid. If we do encounter unexpected resistance, we'll have to react with Frag Orders. Quick and accurate reports from Scouts and companies will be very important. As the enemy withdraws, we will maintain pressure and overrun him. Our mission is more to gain and maintain contact with the enemy than to seize terrain. We must keep the delaying force off guard and take advantage of any opportunity to destroy his forces. We must reach his main defensive belt before he has time to dig in.
- b. Companies will move from TAA DOG to the LD using the routes shown. Scouts will cross the LD one hour prior to the lead companies and screen 3-5 KM forward of the battalion.
- c. (Show Diamond Formation slide) After crossing the LD we will move forward in a battalion diamond with A Co leading. Positions of other units are as shown.
- d. After the Scouts make initial contact they will, on order, screen the Bn western flank.
- e. (Show Operations Overlay slide) I anticipate assaulting our objectives from the march, with A Co seizing OBJ BRONZE, B Co seizing TIN, and C Co seizing ZINC.
- f. After a brief consolidation, we will continue, on order, to OBJ COPPER using the same formation. We will assault COPPER with three companies on line, from left to right C Co, A Co, and B Co. D Company will provide support by fire and be prepared to assume any lead company mission.
- g. 1-10 AR has priority of Copperhead and FA fires within the Brigade. Within the Battalion, Scouts will have priority of FA fires while leading the formation, then A Company as Advance Guard. Other details of fire support are in OPORD 300 and the Fire Support Overlay from OPORD 30.

### 4. Command and Signal

Command Group, consisting of the Bn Cdr, S3, and FSO will follow A Co, in the center of the formation.

## APPENDIX C

### Fragmentary Order Contents and Scoring Guidelines

Elements from FRAGOs (listed below) are scored as follows:

- Y = Yes - the item was included either verbatim, or repeated in recognizable form.  
N = No - the item was not repeated, or it was repeated inaccurately.

Divide total "Y" ratings by total number of items scored, multiply by 100 (If a scorer is unsure of the appropriate rating, the item will be reviewed by an SME and the appropriate Y or N rating will be assigned).

**Scoring Templates:** The following are scoring templates for company FRAGOs (identified by "A," "B," and "C" at the end of each FRAGO number) for the test scenario and DCEs, and platoon FRAGOs for the DCEs. The templates are based on the scripted Bn FRAGOs and provide the basis for scoring each FRAGO.

<u>Content</u>	<u>Rating</u>
<u>DCE Test Event #1</u>	
<b>B Co:</b>	
[ENEMY SITUATION]	
Enemy unit type & size: MRC+ (11 BMPs, 4 tanks, 1 ZSU)	Y N
Location: Vic CP 9 (ES748879)	Y N
Activity: Digging in or defending	Y N
[FRIENDLY SITUATION]	
Parent unit/activity: 1-10 AR attacks	Y N
when: On Order	Y N
where: vic CP 9 (ES748879)	Y N
why: to destroy enemy force (MRC+)	Y N
Adj unit-left: A Co	Y N
activity: support by fire	Y N
-right: Sct Plt	Y N
activity: screen Bn west flank	Y N
-rear: D Co	Y N
activity: follow and support B Co	Y N

[MISSION]

Unit/activity: B Co attacks	Y	N
when: On order	Y	N
where: along AXIS GREEN (ES760915 - 740900 - CP 9)	Y	N
why: to seize OBJ OAK (hill vic ES747877/CP 9)	Y	N

[COORDINATION]

Assault LD: ridge line from ES751915 -780897	Y	N
Final Coordination Line: NE-SW redball (road) 800 m NW of OAK.	Y	N
Report when ready to execute (REDCON1)	Y	N

1st Plt/B Co

[ENEMY SITUATION]

Enemy unit type & size: MRC+ (11 BMPs, 4 tanks, 1 ZSU)	Y	N
Location: CP 9 (ES748879)	Y	N
Activity: digging in or defending	Y	N

[FRIENDLY SITUATION]

Parent unit/activity: B Co attacks	Y	N
when: On order	Y	N
where: along AXIS GREEN (ES760915 - 740900 - CP 9)	Y	N
why: to seize OBJ OAK (hill vic ES747877/CP 9)	Y	N

[COORDINATION]

Assault LD: ridge line from ES751915 -780897	Y	N
Final Coordination Line: NE-SW redball (road) 800 m NW of OAK.	Y	N
Report when ready to execute (REDCON1)	Y	N

DCE Test Event #2

B Co:

[ENEMY SITUATION]

(Implied by current contact--may be omitted)

[FRIENDLY SITUATION]

Parent unit/activity: Bn (-) continues attack	Y	N
where: on OBJ STEEL	Y	N
adj unit-rear: D Co	Y	N
activity: follow & spt B Co	Y	N

[MISSION]

Unit/activity: (B Co) Action right: sweep or assault	Y N
where: enemy position vic ES755828	Y N
why: to destroy (or overrun) enemy	Y N
subsequent activity: (continue) attack	Y N
where: OBJ TIN	Y N

1st Plt/B Co:

[ENEMY SITUATION]  
(Implied by current contact--may be omitted)

[FRIENDLY SITUATION]

Parent unit/activity: B Co sweeps/assaults	Y N
where: enemy position vic ES755828	Y N
why: to destroy (or overrun) enemy	Y N
subsequent activity: (continue) attack	Y N
where: OBJ TIN	Y N

DCE Test Event #3

B Co:

[ENEMY SITUATION]

Enemy activity/level: heavy defense	Y N
where: OBJ COPPER <sup>1</sup>	Y N

[FRIENDLY SITUATION]

Parent unit/activity: Bn aborts attack and withdraws	Y N
when: now	Y N
where: to PL CARL	Y N
why: to establish hasty defenses	Y N

[MISSION]

Unit/activity: 1st Plt withdraws	Y N
when: now	Y N
where: to PL CARL	Y N
why: to establish hasty defenses	Y N

1st Plt/B Co:

[ENEMY SITUATION]

Enemy activity/level: heavy defense	Y N
where: OBJ COPPER	Y N

---

<sup>1</sup> If limited loss contingency was required, "where" is OBJ BRASS.

[FRIENDLY SITUATION]

Parent unit/activity: B Co withdraws Y N  
when: now Y N  
where: to PL CARL Y N  
why: to establish hasty defenses Y N

DCE Test Event #4

B Co:

[ENEMY SITUATION]

Enemy unit type & size: MRR Y N  
Location: 8 KM S of PL CARL Y N  
Activity: attacking/moving NW Y N

[FRIENDLY SITUATION]

Parent unit/activity: 1-10 AR withdraws Y N  
when: on order Y N  
where: to TAA HAWK (ES783920) Y N

Adj unit-left: A Co Y N  
activity: withdraws along Rte White Y N  
-right: Sct Plt Y N  
activity: screens Bn W flank Y N  
-rear: D Co and TF 3-4 AR Y N  
activity: D Co: covers DLIC withdrawal and Y N  
assists their disengagement Y N  
TF 3-4 AR defends along PL JIM Y N

[MISSION]

Unit/activity: B Co withdraws Y N  
when: on order Y N  
where: along Rte Red (SP, ES771785; CP 2, ES753824;  
CP 3, ES755845; CP 4, ES762874; RP, ES769898) Y N

[SUBORDINATE UNIT TASKS]

\_\_\_ Plt (DLIC)  
- Est & maintain contact with enemy Y N  
- Guard main body Y N  
- Delay enemy advance Y N  
- avoid being overrun Y N

[COORDINATION]

Report when ready to move (REDCON1) Y N

**1st Plt/B Co**

**[ENEMY SITUATION]**

Enemy unit type & size: MRR	Y N
Location: 8 KM S of PL CARL	Y N
Activity: attacking/moving NW	Y N

**[FRIENDLY SITUATION]**

Parent unit/activity: B Co withdraws	Y N
when: on order	Y N
where: along Rte Red to TAA HAWK (ES783920)	Y N

Adj unit-left: A Co	Y N
activity: withdraws along Rte White	Y N
-right: Sct Plt	Y N
activity: screens Bn W flank	Y N
-rear: D Co and TF 3-4 AR	Y N
activity: D Co: covers DLIC withdrawal and assists their disengagement	Y N
TF 3-4 AR defends along PL JIM	Y N

**[COORDINATION]**

Report when ready to move (REDCON1)	Y N
-------------------------------------	-----

Plt Ldr designates route of march (Rte RED, SP, ES771785; CP2, ES753824; CP3, ES755845; CP4, ES762874; RP, ES769898) OR direct platoon to follow.	Y N
--	-----

## APPENDIX D

### Intelligence Report Contents and Scoring Guidelines

Elements from INTELs (listed below) are scored as follows:

Y = Yes - the item was included either verbatim, or repeated in recognizable form.

N = No - the item was not repeated, or it was repeated inaccurately.

Divide total "Y" ratings by total number of items scored, multiply by 100. If scorer is unsure of the appropriate rating, the item will be reviewed by an SME to determine the appropriate Y or N rating.

<u>Script Time</u>	<u>Content</u>	<u>Rating</u>
<u>DCE Event 1</u>		
	T+5:00 What: MRC(+)	Y N
	Where: ES748879	Y N
	Activity: Preparing Def Posns	Y N
	Heading: Stationary	Y N
T+18:00	What: Enemy Co (-)	Y N
	Where: ES875870	Y N
	Activity: Defending (hasty def)	Y N
	What: 1-91 Mech	Y N
	Activity: Attacking (executing hasty attack)	Y N
<u>DCE Event 2</u>		
T+13:00	What: 1-91 Mech	Y N
	Where: PL BOB	Y N
	Activity: continuing mission	Y N
T+16:00	What: 1-91 Mech	Y N
	Where: OBJ IRON	Y N
	Activity: in contact, attacking	Y N
	Heading:	Y N
T+22:00	What: MRC(+)	Y N
	Where: OBJ IRON	Y N
	Activity: in hasty defenses	Y N
	What: 1-91 Mech	Y N

Where: OBJ IRON	Y	N
Activity: seized OBJ/overran enemy, consolidating	Y	N

DCE Event 3

T+5:00	What: MRC(+)	Y	N
	#: 3	Y	N
	Where: ES827724, ES843727, ES857744	Y	N
	Activity: defending (dug in, good fighting positions)	Y	N
T+6:00	What: BMPs, T-80s	Y	N
(spot	#: 15, 6	Y	N
report)	Where: OBJ COPPER	Y	N
	Activity: defending (dug in)	Y	N
T+12:00	What: 1-91 Mech	Y	N
	Where: N. of OBJ BRASS	Y	N
	Activity: in heavy contact	Y	N
T+17:00	What: 1-91 Mech	Y	N
	Where: to PL CARL	Y	N
	Activity: withdrawing	Y	N
	(contingent report-may have been omitted)		

DCE Event 4

T+12:00	What: 1-91 Mech	Y	N
	Where: in sector	Y	N
	Activity: withdrawing under increased enemy pressure	Y	N
T+17:00	What: 1-91 Mech DLIC	Y	N
	Activity: delaying (initiates movement)	Y	N
	Heading: rearward	Y	N
T+29:00	What: 1-91 Mech	Y	N
	Where: PL JIM	Y	N
	Activity: beginning passage of lines	Y	N

APPENDIX E

Battle Master and PVD Logs

DCE BATTLEMASTER LOG

DATE: \_\_\_\_\_

FILE: \_\_\_\_\_

BATTLEMASTER: \_\_\_\_\_

ASSISTANT BATTLEMASTER: \_\_\_\_\_

<u>Position</u>	<u>Sim*</u>	<u>Call Sign</u>	<u>Vehicle ID*</u>
Bn Cmdr	3B	Y06	_____
S3	2B	Y03	_____
B Co Cmdr	2D	B06	_____
B Co XO	2C	B05	_____
Plt Ldr	4A	B11	_____
Plt Sgt	3C	B14	_____
Plt Ldr Wing	4B	C12	_____
Plt Sgt Wing	4C	C13	_____

\*Be sure to note changes in Sim and Vehicle ID if there is a change in simulator(s) assignment.

DCA Notified to Turn DataLogger ON: \_\_\_\_\_:\_\_\_\_\_:\_\_\_\_\_  
(Time) (Flag)

**TURN VIDEO CAMERAS ON**

DCE BATTLE MASTER LOG

**DCE 1:**

- \_\_\_\_\_ Exercise begun
  - \_\_\_\_\_ Bn Intel report sent to Bn Cdr
  - \_\_\_\_\_ Battalion **FRAGO/Overlay** Issued
  - \_\_\_\_\_ B Co reports crossing FRAGO FCL
  - \_\_\_\_\_ Exercise ended (Circle one: Completed Halted)
- If event halted: distance between FCL and closest B Co Vehicle (use PVD ruler): \_\_\_\_\_

**DCE 2:**

- \_\_\_\_\_ Exercise begun
  - \_\_\_\_\_ B Co reports Contact
  - \_\_\_\_\_ Battalion **FRAGO/Overlay** Issued
  - \_\_\_\_\_ B Co reports arrival on OBJ TIN
  - \_\_\_\_\_ Exercise ended (Circle one: Completed Halted)
- If event halted: distance between Obj TIN and closest B Co vehicle (use PVD ruler): \_\_\_\_\_

**Send Flags and Record:** Breakdowns (who, what, start, and stop);  
Halt in Exercise (why, start and stop); Equipment Problems;  
Anything Noteworthy or Out of the Ordinary.

---

---

---

---

---

---

---

---

---

---

DCE BATTLE MASTER LOG

**DCE 3:**

\_\_\_\_\_ Exercise begun

\_\_\_\_\_ Bn Intel report sent to Bn Cdr

\_\_\_\_\_ Battalion **FRAGO/Overlay** Issued

\_\_\_\_\_ B Co reports crossing N PL CARL

\_\_\_\_\_ Exercise ended (Circle one: Completed Halted)

If event halted: distance between PL CARL and closest B Co Vehicle (use PVD ruler): \_\_\_\_\_

**DCE 4:**

\_\_\_\_\_ Exercise begun

\_\_\_\_\_ Bn Intel report sent to Bn Cdr

\_\_\_\_\_ Battalion **FRAGO/Overlay** Issued

\_\_\_\_\_ **Decision to displace**

\_\_\_\_\_ B Co reports crossing PL BILL

\_\_\_\_\_ Exercise ended (Circle one: Completed Halted)

If event halted: distance between PL BILL and closest B Co vehicle (use PVD ruler): \_\_\_\_\_

CALL COMPUTER ROOM TO STOP TAPE

TURN VIDEO CAMERAS OFF

**Send Flags and Record:** Breakdowns (who, what, start, and stop);  
Halt in Exercise (why, start and stop); Equipment Problems;  
Anything Noteworthy or Out of the Ordinary.

---

---

---

---

---

---

---

---

---

---

DCE PVD OPERATOR

DATE: \_\_\_\_\_

FILE: DCE \_ \_ \_ \_ \_

PVD OPERATOR: \_\_\_\_\_

<u>Position</u>	<u>Sim*</u>	<u>Call Sign</u>	<u>Vehicle ID*</u>
Bn Cmdr	3B	Y06	_____
S3	2B	Y03	_____
B Co Cmdr	2D	B06	_____
B Co XO	2C	B05	_____
Plt Ldr	4A	B11	_____
Plt Sgt	4C	B14	_____
Plt Ldr Wing	4B	B12	_____
Plt Sgt Wing	3C	B13	_____

\*Be sure to note changes in Sim and Vehicle ID if there is a change in simulator(s) assignment.

DCA Notified to Turn DataLogger ON: \_\_\_\_\_:\_\_\_\_\_:\_\_\_\_\_  
(Time) (Flag)

TURN VIDEO CAMERAS ON

**DCE Test Event 1: ASSAULT.2**

T+5 - BATTLEMASTER DIRECTS BN TO BEGIN MOVING.

T+5 - MESSAGE TO Y02 FROM N02 [BDE O&I]: ENEMY REINFORCED MRC VIC ES748879: STATIONARY, APPEARS TO BE PREPARING DEFENSIVE POSITIONS.

T+5:45 - MESSAGE TO Y06 FROM N06 [BDE CMD]: EXECUTE A HASTY ATTACK TO CLEAR THE ENEMY POSITION VIC CP 9.

T+7 - SCOUTS REQUEST INSTRUCTIONS; BN CDR DIRECTS SCOUTS TO MOVE TO SCREEN RIGHT FLANK.

T+10 - TOC ISSUES FRAGO.

T+12 - UNITS REPORT REDCON 1.

T+18 - 1-91 IN REPORTS MODERATE CONTACT VIC ES875870; EN CO(-) IN HASTY DEFENSES, EXECUTING HASTY ATTACK.

\_\_\_\_\_ Manned platoon crosses FRAGO FCL

\_\_\_\_\_ Manned platoon reports crossing FRAGO FCL

EVENT TERMINATED WHEN B CO CROSSES FCL OR AT T+25 MIN.

**Send Flags and Record:** Breakdowns (who, what, start and stop);  
Halt in Exercise (why, start and stop); Equipment Problems;  
Anything Noteworthy or Out of the Ordinary.

---

---

---

---

---

---

---

---

---

---

**DCE Test Event 2: FLANK ATTACK**

T+5 - BATTLEMASTER DIRECTS BN TO BEGIN MOVING.

T+9 - BN CDR ISSUES FRAGO.

\_\_\_\_\_ Manned platoon reports contact

\_\_\_\_\_ Manned platoon reports arrival on OBJ TIN

T+13 - 1-91 IN REPORTS PL BOB, CONTINUING MISSION.

T+16 - 1-91 IN REPORTS CONTACT VIC OBJ IRON: ATTACKING.

T+22 - 1-91 REPORTS OBJ IRON SEIZED. OVERRAN ESTIMATED MRC(+) IN HASTY DEFENSES. CONSOLIDATING OBJ.

EVENT TERMINATED WHEN B CO SEIZES TIN OR T+25 MIN.

**Send Flags and Record:** Breakdowns (who, what, start and stop);  
Halt in Exercise (why, start and stop); Equipment Problems;  
Anything Noteworthy or Out of the Ordinary.

---

---

---

---

---

---

---

---

---

---

**DCE Test Event 3: ABORTED ATTACK**

T+5 - BATTLEMASTER DIRECTS BN TO EXECUTE ATTACK AT (T+10).

T+5 - MESSAGE TO Y02 FROM N02 [BDE O&I]: ESTIMATED THREE MRCS, REINFORCED WITH TANKS, DUG-IN AT ES827724, ES843727 AND ES857744.

T+6 - MESSAGE TO Y02 FROM N02 [BDE O&I]: AIR CAV REPORTS 15 BMPS AND 6 T-80S DUG-IN ON COPPER.

T+12 - 1-91 IN REPORTS HEAVY CONTACT NORTH OF OBJ BRASS.

T+15 - BN CDR ISSUES FRAGO: STOPS ATTACK AND ORDERS WITHDRAWAL TO PL CARL.

T+17 - (IF NOT ALREADY ACCOMPLISHED) 1-91 IN REPORTS WITHDRAWAL TO PL CARL.

\_\_\_\_\_ Manned platoon crosses North of PL CARL (withdrawing)

\_\_\_\_\_ Manned platoon reports crossing North of PL CARL

EVENT TERMINATED WHEN MANNED PLT CROSSES PL CARL IN RETROGRADE OR AT T+25 MIN.

**Send Flags and Record:** Breakdowns (who, what, start and stop);  
Halt in Exercise (why, start and stop); Equipment Problems;  
Anything Noteworthy or Out of the Ordinary.

---

---

---

---

---

---

---

---

---

---

**DCE Test Event 4: WITHDRAW**

T+5 - TOC ISSUES FRAGO.

T+12 - 1-91 IN REPORTS ENEMY PRESSURE IN SECTOR INCREASING; EXECUTING WITHDRAWAL NOW.

T+17 - 1-91 IN DLIC REPORTS AND INITIATES MOVEMENT REARWARD.

\_\_\_\_\_ Manned platoon reaches SP  
\_\_\_\_\_ Manned platoon reports SP

\_\_\_\_\_ Manned platoon reaches CP 2  
\_\_\_\_\_ Manned platoon reports CP 2

\_\_\_\_\_ Manned platoon reaches CP 3  
\_\_\_\_\_ Manned platoon reports CP 3

\_\_\_\_\_ Manned platoon reaches CP 4  
\_\_\_\_\_ Manned platoon reports CP 4

\_\_\_\_\_ Manned platoon reached RP  
\_\_\_\_\_ Manned platoon reports RP

T+29 1-91 IN REPORTS PL JIM; BEGINS PASSAGE OF LINES.

\_\_\_\_\_ Manned platoon crosses PL BOB  
\_\_\_\_\_ Manned platoon reports crossing PL BOB

EVENT TERMINATED WHEN MANNED PLT CROSSES PL BOB OR AT T+35 MIN.

**Send Flags and Record:** Breakdowns (who, what, start and stop);  
Halt in Exercise (why, start and stop); Equipment Problems;  
Anything Noteworthy or Out of the Ordinary.

---

---

---

---

---

---

---

---

**Out of Sector/Misoriented Vehicle(s):**

EVENT #: \_\_\_\_\_  
\_\_\_\_\_ Vehicle(s) out of sector or misoriented (Circle which)      Vehicle(s): \_\_\_\_\_  
\_\_\_\_\_ Vehicle(s) return in sector or correctly orients (circle which)  
What caused vehicle to return in sector or to correctly orient (self/other vehicles/ECR)? \_\_\_\_\_

**Out of Sector/Misoriented Vehicle(s):**

EVENT #: \_\_\_\_\_  
\_\_\_\_\_ Vehicle(s) out of sector or misoriented (Circle which)      Vehicle(s): \_\_\_\_\_  
\_\_\_\_\_ Vehicle(s) return in sector or correctly orients (circle which)  
What caused vehicle to return in sector or to correctly orient (self/other vehicles/ECR)? \_\_\_\_\_

**Out of Sector/Misoriented Vehicle(s):**

EVENT #: \_\_\_\_\_  
\_\_\_\_\_ Vehicle(s) out of sector or misoriented (Circle which)      Vehicle(s): \_\_\_\_\_  
\_\_\_\_\_ Vehicle(s) return in sector or correctly orients (circle which)  
What caused vehicle to return in sector or to correctly orient (self/other vehicles/ECR)? \_\_\_\_\_

**Out of Sector/Misoriented Vehicle(s):**

EVENT #: \_\_\_\_\_  
\_\_\_\_\_ Vehicle(s) out of sector or misoriented (Circle which)      Vehicle(s): \_\_\_\_\_  
\_\_\_\_\_ Vehicle(s) return in sector or correctly orients (circle which)  
What caused vehicle to return in sector or to correctly orient (self/other vehicles/ECR)? \_\_\_\_\_

**Out of Sector/Misoriented Vehicle(s):**

EVENT #: \_\_\_\_\_  
\_\_\_\_\_ Vehicle(s) out of sector or misoriented (Circle which)      Vehicle(s): \_\_\_\_\_  
\_\_\_\_\_ Vehicle(s) return in sector or correctly orients (circle which)  
What caused vehicle to return in sector or to correctly orient (self/other vehicles/ECR)? \_\_\_\_\_

**Out of Sector/Misoriented Vehicle(s):**

EVENT #: \_\_\_\_\_  
\_\_\_\_\_ Vehicle(s) out of sector or misoriented (Circle which)      Vehicle(s): \_\_\_\_\_  
\_\_\_\_\_ Vehicle(s) return in sector or correctly orients (circle which)  
What caused vehicle to return in sector or to correctly orient (self/other vehicles/ECR)? \_\_\_\_\_

**Out of Sector/Misoriented Vehicle(s):**

EVENT #: \_\_\_\_\_  
\_\_\_\_\_ Vehicle(s) out of sector or misoriented (Circle which)      Vehicle(s): \_\_\_\_\_  
\_\_\_\_\_ Vehicle(s) return in sector or correctly orients (circle which)  
What caused vehicle to return in sector or to correctly orient (self/other vehicles/ECR)? \_\_\_\_\_

Biographical Questionnaire

ADMIN: Date \_\_\_\_\_ Partic # \_\_\_\_\_ Dty Pos \_\_\_\_\_ Revised 1/14/92  
 \* \* \* \* \*

**BIOGRAPHICAL QUESTIONNAIRE**

Name \_\_\_\_\_ SSN \_\_\_\_\_ - \_\_\_\_\_ - \_\_\_\_\_

1. Age \_\_\_\_\_ years 2. Current Army Rank \_\_\_\_\_

3. Current unit of assignment \_\_\_\_\_

4. Military Specialty: 12A 12B 12C 19E 19K Other \_\_\_\_\_

5. Total time on active duty: \_\_\_\_\_ years / \_\_\_\_\_ months

6. Total active duty time in Armor units (include Cavalry):  
 \_\_\_\_\_ yrs / \_\_\_\_\_ months

7. How much experience as a crewmember have you had with the following families of vehicles?

a. M1 \_\_\_\_\_ / \_\_\_\_\_  
 yrs mos

c. M113 \_\_\_\_\_ / \_\_\_\_\_  
 yrs mos

b. M60 \_\_\_\_\_ / \_\_\_\_\_  
 yrs mos

d. M2/M3 \_\_\_\_\_ / \_\_\_\_\_  
 yrs mos

8. Circle your present Duty Position in your current unit:

Plt Ldr Co Cdr Co XO Bn S2 Bn S3 Bn XO Student

Driver Loader Gunner Tank Cdr Plt Sgt Instructor

Other \_\_\_\_\_

9. How much experience do you have in each of the following TO&E (combat maneuver unit) positions?

a. Driver \_\_\_\_\_ / \_\_\_\_\_  
 yrs mos

h. Co XO \_\_\_\_\_ / \_\_\_\_\_  
 yrs mos

b. Loader \_\_\_\_\_ / \_\_\_\_\_  
 yrs mos

i. Co Cdr \_\_\_\_\_ / \_\_\_\_\_  
 yrs mos

c. Gunner \_\_\_\_\_ / \_\_\_\_\_  
 yrs mos

j. Bn S2 \_\_\_\_\_ / \_\_\_\_\_  
 yrs mos

d. Tnk Cdr \_\_\_\_\_ / \_\_\_\_\_  
 yrs mos

k. Bn S3 \_\_\_\_\_ / \_\_\_\_\_  
 yrs mos

e. Plt Sgt \_\_\_\_\_ / \_\_\_\_\_  
 yrs mos

l. Bn Staff \_\_\_\_\_ / \_\_\_\_\_  
 yrs mos



16. People commonly report feeling uncomfortable using computers. Please circle below the value that best describes how you feel (in general) about using computers.

1	2	3	4	5	6	7
Very Uncomfortable			Neutral	Very Comfortable		

17. Highest civilian education level:

- \_\_\_\_\_ High School Diploma/GED
- \_\_\_\_\_ Some College
- \_\_\_\_\_ College Degree (BA/BS)
- \_\_\_\_\_ Postgraduate work

18. Total active duty time in combat maneuver units (for example, 194th AB, 2d AD): (Please list years/months)

CONUS \_\_\_\_\_ / \_\_\_\_\_ USAREUR \_\_\_\_\_ / \_\_\_\_\_ KOREA \_\_\_\_\_ / \_\_\_\_\_

## APPENDIX G

### Summary of Biographical Data

Table G-1.

Average Years of Military Experience, by Condition

	Officer		NCO/Enlisted	
	CVCC	Baseline	CVCC	Baseline
Active duty	6.34 (4.55) <u>n</u> =31	6.52 (4.03) <u>n</u> =39	4.84 (4.14) <u>n</u> =61	6.46 (4.93) <u>n</u> =78
In armor units	3.80 (2.91) <u>n</u> =31	4.48 (2.58) <u>n</u> =40	4.34 (3.39) <u>n</u> =61	5.58 (4.42) <u>n</u> =77
In M1 units	1.26 (1.10) <u>n</u> =31	1.78 (1.40) <u>n</u> =39	2.85 (2.00) <u>n</u> =61	3.01 (2.89) <u>n</u> =78
In M60 units	1.09 (2.30) <u>n</u> =31	1.58 (1.92) <u>n</u> =32	1.29 (2.79) <u>n</u> =61	2.81 (3.77) <u>n</u> =60

Table G-2.

Average Years of Officer Experience in Primary Duty Positions, by Condition

	CVCC	Baseline
Battalion S3	.15 (.40) <u>n</u> =31	.14 (.57) <u>n</u> =30
Other battalion staff	.37 (.73) <u>n</u> =31	.42 (.74) <u>n</u> =35
Company Commander	.51 (.92) <u>n</u> =31	.52 (.82) <u>n</u> =33
Company XO	.52 (.65) <u>n</u> =31	.82 (.64) <u>n</u> =35
Platoon Leader	1.27 (.68) <u>n</u> =31	1.12 (.74) <u>n</u> =39

Table G-3.

Average Years of NCO/Enlisted Experience in Primary Duty Positions, by Condition

	CVCC	Baseline
Platoon Sergeant	.10 (.39) n=61	.44 (1.08) n=54
Tank Commander	.72 (2.13) n=61	1.97 (2.93) n=61
Gunner	1.35 (2.03) n=61	1.76 (2.11) n=71
Driver	1.42 (1.20) n=61	1.48 (1.47) n=75

Note. Standard deviations are in parentheses.

## APPENDIX H

### Source Tables from MANOVA Analyses, By Measure

Exposure to Opposing Force						
Source of Variation	SS	DF	MS	F	Sig of F	
WITHIN CELLS	14407.48	261	55.20			
CONSTANT	10171.49	1	10171.49	184.26	.000	
COND	91.02	1	91.02	1.65	.200	
ECHELON	804.80	2	402.40	7.29	.001	
COND BY ECHELON	5.85	2	2.92	.05	.948	

Exposure to Opposing Force with Battalion Echelon Excluded						
Source of Variation	SS	DF	MS	F	Sig of F	
WITHIN CELLS	7705.36	199	38.72			
CONSTANT	5068.85	1	5068.85	130.91	.000	
COND	60.57	1	60.57	1.56	.212	
ECHELON	233.53	1	233.53	6.03	.015	
COND BY ECHELON	5.60	1	5.60	.14	.704	

Exposure to Opposing Force--Abort Exercise (#4)						
Source of Variation	SS	DF	MS	F	Sig of F	
WITHIN CELLS	3355.08	53	63.30			
MWITHIN EXERCISE(4)	651.06	1	651.06	10.28	.002	
COND BY MWITHIN EXERCISE(4)	251.13	1	251.13	3.97	.052	

Range to OPFOR at Displacement						
Source of Variation	SS	DF	MS	F	Sig of F	
WITHIN CELLS	5037805.70	5	1007561.1			
CONSTANT	429442445.2	1	429442445	426.22	.000	
COND	160417.16	1	160417.16	.16	.706	

Number of Manned Platoon Vehicles <100 Meters Apart						
Source of Variation	SS	DF	MS	F	Sig of F	
WITHIN CELLS	11.11	32	.35			
CONSTANT	35.71	1	35.71	102.84	.000	
COND	1.86	1	1.86	5.36	.027	

Number of Manned Platoon Vehicles >100 and <100 Meters Apart						
Source of Variation	SS	DF	MS	F	Sig of F	
WITHIN CELLS	13.86	32	.43			
CONSTANT	144.32	1	144.32	333.09	.000	
COND	.08	1	.08	.18	.676	

Number of Manned Platoon Vehicles >200 Meters Apart						
Source of Variation	SS	DF	MS	F	Sig of F	
WITHIN CELLS	11.55	32	.36			
CONSTANT	24.69	1	24.69	68.41	.000	
COND	2.69	1	2.69	7.47	.010	

Number of Exercises Completed Within Time						
Source of Variation	SS	DF	MS	F	Sig of F	
WITHIN CELLS	8.75	7	1.25			
CONSTANT	11.25	1	11.25	9.00	.020	
COND	.14	1	.14	.11	.749	

Time to Complete the Exercise						
Source of Variation	SS	DF	MS	F	Sig of F	
WITHIN CELLS	497.46	32	15.55			
CONSTANT	22540.09	1	22540.09	1449.93	.000	
COND	4.77	1	4.77	.31	.583	

Distance from Scripted End Point of Exercise--Company and Platoon Data					
Source of Variation	SS	DF	MS	F	Sig of F
WITHIN CELLS	1461109.50	7	208729.93		
CONSTANT	18360545.32	1	18360545	87.96	.000
COND	1459534.36	1	1459534.4	6.99	.033

Distance from Scripted End Point of Exercise--Platoon Data					
Source of Variation	SS	DF	MS	F	Sig of F
WITHIN CELLS	1281800.54	7	183114.36		
CONSTANT	17458161.04	1	17458161	95.34	.000
COND	1307099.41	1	1307099.4	7.14	.032

Percentage of Time at a Halt--Battalion, Company and Platoon Echelons					
Source of Variation	SS	DF	MS	F	Sig of F
WITHIN CELLS	65197.12	263	247.90		
CONSTANT	847770.48	1	847770.48	3419.84	.000
COND	864.91	1	864.91	3.49	.063
ECHELON	5021.59	2	2510.80	10.13	.000
COND BY ECHELON	2016.53	2	1008.27	4.07	.018

Percentage of Time at a Halt--Simple Test					
Source of Variation	SS	DF	MS	F	Sig of F
WITHIN CELLS	68634.80	266	258.03		
CONSTANT	892091.36	1	892091.36	3457.38	.000
ECHELON(1)	2720.16	1	2720.16	10.54	.001
ECHELON(2)	3653.78	1	3653.78	14.16	.000

Percentage of Time at a Halt--Simple Effects Test					
Source of Variation	SS	DF	MS	F	Sig of F
WITHIN CELLS	65197.12	263	247.90		
CONSTANT	847770.48	1	847770.48	3419.84	.000
ECHELON	5021.59	2	2510.80	10.13	.000
COND W ECHELON(1)	377.36	1	377.36	1.52	.218
COND W ECHELON(2)	1677.49	1	1677.49	6.77	.010
COND W ECHELON(3)	1382.82	1	1382.82	5.58	.019

Percentage of Time at a Halt--Company and Platoon Echelons					
Source of Variation	SS	DF	MS	F	Sig of F
WITHIN CELLS	45506.73	200	227.53		
CONSTANT	574084.88	1	574084.88	2523.08	.000
COND	3015.21	1	3015.21	13.25	.000
ECHELON	2.77	1	2.77	.01	.912
COND BY ECHELON	143.33	1	143.33	.63	.428

Velocity while Moving (km/hr)					
Source of Variation	SS	DF	MS	F	Sig of F
WITHIN CELLS	27633.25	260	106.28		
CONSTANT	228952.10	1	228952.10	2154.20	.000
COND	1459.72	1	1459.72	13.73	.000
ECHELON	86.80	2	43.40	.41	.665
COND BY ECHELON	345.27	2	172.64	1.62	.199

Percentage of Time Velocity >40km/hr					
Source of Variation	SS	DF	MS	F	Sig of F
WITHIN CELLS	134154.06	260	515.98		
CONSTANT	1057197.40	1	1057197.4	2048.92	.000
COND	7957.37	1	7957.37	15.42	.000
ECHELON	589.12	2	294.56	.57	.566
COND BY ECHELON	1777.85	2	888.93	1.72	.181

Distance Travelled						
Source of Variation	SS	DF	MS	F	Sig of F	
WITHIN CELLS	1897959822	263	7216577.3			
CONSTANT	6303624103	1	6.304E+09	873.49	.000	
COND	18714279.24	1	18714279	2.59	.109	
ECHELON	73001764.17	2	36500882	5.06	.007	
COND BY ECHELON	16503560.73	2	8251780.4	1.14	.320	

Distance Travelled--Simple Test						
Source of Variation	SS	DF	MS	F	Sig of F	
WITHIN CELLS	1934973612	266	7274336.9			
CONSTANT	6725013697	1	6.725E+09	924.48	.000	
ECHELON(1)	39397512.39	1	39397512	5.42	.021	
ECHELON(2)	58159443.12	1	58159443	8.00	.005	

Distance Travelled--Battalion Echelon						
Source of Variation	SS	DF	MS	F	Sig of F	
WITHIN CELLS	413198990.2	63	6558714.1			
CONSTANT	1189008135	1	1.189E+09	181.29	.000	
COND	25181378.66	1	25181379	3.84	.054	

Fuel Used						
Source of Variation	SS	DF	MS	F	Sig of F	
WITHIN CELLS	3282.71	263	12.48			
CONSTANT	14565.33	1	14565.33	1166.93	.000	
COND	110.63	1	110.63	8.86	.003	
ECHELON	22.90	2	11.45	.92	.401	
COND BY ECHELON	10.51	2	5.25	.42	.657	

Time to Acquire Targets						
Source of Variation	SS	DF	MS	F	Sig of F	
WITHIN CELLS	378.90	196	1.93			
CONSTANT	1015.54	1	1015.54	525.33	.000	
COND	2.45	1	2.45	1.27	.261	
ECHELON	.03	2	.01	.01	.993	
COND BY ECHELON	3.22	2	1.61	.83	.437	

Time Between Lases to Different Targets						
Source of Variation	SS	DF	MS	F	Sig of F	
WITHIN CELLS	96.11	188	.51			
CONSTANT	109.24	1	109.24	213.68	.000	
COND	.96	1	.96	1.88	.172	
ECHELON	1.39	2	.70	1.36	.258	
COND BY ECHELON	.37	2	.18	.36	.700	

Minimum Time Between Lases to Different Targets						
Source of Variation	SS	DF	MS	F	Sig of F	
WITHIN CELLS	68.45	188	.36			
CONSTANT	18.33	1	18.33	50.35	.000	
COND	3.65	1	3.65	10.03	.002	
ECHELON	1.64	2	.82	2.25	.108	
COND BY ECHELON	1.23	2	.62	1.69	.187	

Time from Lase to First Fire						
Source of Variation	SS	DF	MS	F	Sig of F	
WITHIN CELLS	31.30	144	.22			
CONSTANT	12.33	1	12.33	56.72	.000	
COND	.02	1	.02	.07	.787	
ECHELON	.71	2	.35	1.62	.201	
COND BY ECHELON	.65	2	.33	1.50	.227	

Maximum Lase Range						
Source of Variation	SS	DF	MS	F	Sig of F	
WITHIN CELLS	140295427.9	212	661770.89			
CONSTANT	1196192693	1	1.196E+09	1807.56	.000	
COND	7818018.05	1	7818018.1	11.81	.001	
ECHELON	4347723.98	2	2173862.0	3.28	.039	
COND BY ECHELON	8043746.39	2	4021873.2	6.08	.003	

Maximum Lase Range--Simple Test						
Source of Variation	SS	DF	MS	F	Sig of F	
WITHIN CELLS	157438622.9	215	732272.66			
CONSTANT	1200888999	1	1.201E+09	1639.95	.000	
ECHELON(1)	3431709.72	1	3431709.7	4.69	.032	
ECHELON(2)	401546.24	1	401546.24	.55	.460	

Maximum Lase Range--Simple Effects Test						
Source of Variation	SS	DF	MS	F	Sig of F	
WITHIN CELLS	140295427.9	212	661770.89			
CONSTANT	1196192693	1	1.196E+09	1807.56	.000	
ECHELON	4347723.98	2	2173862.0	3.28	.039	
COND W ECHELON(1)	136170.01	1	136170.01	.21	.651	
COND W ECHELON(2)	13797888.15	1	13797888	20.85	.000	
COND W ECHELON(3)	3209136.84	1	3209136.8	4.85	.029	

Losses/Kills Ratio						
Source of Variation	SS	DF	MS	F	Sig of F	
WITHIN CELLS	14.90	31	.48			
CONSTANT	11.83	1	11.83	24.63	.000	
COND	.49	1	.49	1.02	.321	

Target Hit Range--Battalion, Company and Platoon						
Source of Variation	SS	DF	MS	F	Sig of F	
WITHIN CELLS	37984909.68	102	372401.08			
CONSTANT	360806930.6	1	360806931	968.87	.000	
COND	1430314.31	1	1430314.3	3.84	.053	
ECHELON	1454875.51	2	727437.76	1.95	.147	
COND BY ECHELON	323151.37	2	161575.68	.43	.649	

Target Kill Range--Battalion, Company and Platoon						
Source of Variation	SS	DF	MS	F	Sig of F	
WITHIN CELLS	33259882.43	82	405608.32			
CONSTANT	231840980.5	1	231840980	571.59	.000	
COND	69290.72	1	69290.72	.17	.680	
ECHELON	202216.19	2	101108.09	.25	.780	
COND BY ECHELON	2136751.78	2	1068375.9	2.63	.078	

Target Kill Range--Company and Platoon						
Source of Variation	SS	DF	MS	F	Sig of F	
WITHIN CELLS	29550196.14	72	410419.39			
CONSTANT	260818351.6	1	260818352	635.49	.000	
COND	2229138.84	1	2229138.8	5.43	.023	
ECHELON	136816.85	1	136816.85	.33	.565	
COND BY ECHELON	109950.35	1	109950.35	.27	.606	

Percentage of OPFOR Killed by Manned Simulators						
Source of Variation	SS	DF	MS	F	Sig of F	
WITHIN CELLS	34343.50	30	1144.78			
CONSTANT	38646.00	1	38646.00	33.76	.000	
COND	26.28	1	26.28	.02	.881	

Hits/Round Ratio, Manned Vehicles

Source of Variation	SS	DF	MS	F	Sig of F
WITHIN CELLS	10.25	160	.06		
CONSTANT	7.31	1	7.31	114.03	.000
COND	.05	1	.05	.83	.364
ECHELON	.01	2	.01	.08	.922
COND BY ECHELON	.11	2	.05	.84	.432

Kills/Hit Ratio, Manned Vehicles

Source of Variation	SS	DF	MS	F	Sig of F
WITHIN CELLS	12.13	102	.12		
CONSTANT	11.67	1	11.67	98.15	.000
COND	.00	1	.00	.02	.877
ECHELON	.01	2	.00	.03	.966
COND BY ECHELON	.64	2	.32	2.68	.073

Kills/Round Ratio, Manned Vehicles

Source of Variation	SS	DF	MS	F	Sig of F
WITHIN CELLS	3.54	160	.02		
CONSTANT	1.11	1	1.11	50.11	.000
COND	.00	1	.00	.07	.786
ECHELON	.02	2	.01	.37	.689
COND BY ECHELON	.14	2	.07	3.14	.046

Number of Manned Vehicles Sustaining a Killing Hit

Source of Variation	SS	DF	MS	F	Sig of F
WITHIN CELLS	79.66	32	2.49		
CONSTANT	79.87	1	79.87	32.09	.000
COND	.81	1	.81	.33	.572

Number of Rounds Fired by Manned Vehicles

Source of Variation	SS	DF	MS	F	Sig of F
WITHIN CELLS	10607.80	263	40.33		
CONSTANT	5848.43	1	5848.43	145.00	.000
COND	174.06	1	174.06	4.32	.039
ECHELON	1056.98	2	528.49	13.10	.000
COND BY ECHELON	127.01	2	63.51	1.57	.209

Number of Rounds Fired by Manned Vehicles--Simple Test

Source of Variation	SS	DF	MS	F	Sig of F
WITHIN CELLS	10933.61	266	41.10		
CONSTANT	5733.59	1	5733.59	139.49	.000
ECHELON(1)	141.18	1	141.18	3.43	.065
ECHELON(2)	990.18	1	990.18	24.09	.000

Number of Rounds Fired by Manned Vehicles--Simple Effects Test

Source of Variation	SS	DF	MS	F	Sig of F
WITHIN CELLS	10607.80	263	40.33		
CONSTANT	5848.43	1	5848.43	145.00	.000
ECHELON	1056.98	2	528.49	13.10	.000
COND W ECHELON(1)	.74	1	.74	.02	.892
COND W ECHELON(2)	233.83	1	233.83	5.80	.017
COND W ECHELON(3)	91.24	1	91.24	2.26	.134

Percentage of Call For Fires with Correct Type

Source of Variation	SS	DF	MS	F	Sig of F
WITHIN CELLS	59237.54	36	1645.49		
CONSTANT	41684.39	1	41684.39	25.33	.000
COND	6263.34	1	6263.34	3.81	.059

Time to Transmit Fragmentary Order from Battalion TOC to Platoon Leader

Source of Variation	SS	DF	MS	F	Sig of F
WITHIN CELLS	343.07	24	14.29		
CONSTANT	453.55	1	453.55	31.73	.000
COND	223.37	1	223.37	15.63	.001

Time to Transmit Fragmentary Order from Battalion TOC to Tank Commander						
Source of Variation	SS	DF	MS	F	Sig of F	
WITHIN CELLS	234.61	17	13.80			
CONSTANT	707.80	1	707.80	51.29	.000	
COND	279.92	1	279.92	20.28	.000	

Time to Relay Contact Reports						
Source of Variation	SS	DF	MS	F	Sig of F	
WITHIN CELLS	13.92	44	.32			
CONSTANT	21.24	1	21.24	67.16	.000	
COND	.56	1	.56	1.78	.189	

Time to Relay Spot Reports						
Source of Variation	SS	DF	MS	F	Sig of F	
WITHIN CELLS	30.95	30	1.03			
CONSTANT	18.57	1	18.57	18.00	.000	
COND	.13	1	.13	.13	.721	

Time to Relay Shell Reports						
Source of Variation	SS	DF	MS	F	Sig of F	
WITHIN CELLS	1.82	6	.30			
CONSTANT	4.14	1	4.14	13.62	.010	
COND	.21	1	.21	.69	.439	

Number of Bottom-Up Enemy Reports Relayed						
Source of Variation	SS	DF	MS	F	Sig of F	
WITHIN CELLS	86.21	266	.32			
CONSTANT	40.07	1	40.07	123.63	.000	
COND	8.58	1	8.58	26.47	.000	
ECHELON	14.76	2	7.38	22.78	.000	
COND BY ECHELON	7.40	2	3.70	11.41	.000	

Number of Bottom-Up Enemy Reports Relayed--Simple Test						
Source of Variation	SS	DF	MS	F	Sig of F	
WITHIN CELLS	100.68	269	.37			
CONSTANT	34.88	1	34.88	93.19	.000	
ECHELON(1)	2.94	1	2.94	7.86	.005	
ECHELON(2)	12.01	1	12.01	32.09	.000	

Number of Bottom-Up Enemy Reports Relayed--Simple Effects Test						
Source of Variation	SS	DF	MS	F	Sig of F	
WITHIN CELLS	86.21	266	.32			
CONSTANT	40.07	1	40.07	123.63	.000	
ECHELON	14.76	2	7.38	22.78	.000	
COND W ECHELON(1)	.08	1	.08	.23	.629	
COND W ECHELON(2)	13.45	1	13.45	41.49	.000	
COND W ECHELON(3)	.95	1	.95	2.93	.088	

Duration of Voice Communications between TOC & Battalion Echelon						
Source of Variation	SS	DF	MS	F	Sig of F	
WITHIN CELLS	7.93	107	.07			
CONSTANT	2.99	1	2.99	40.35	.000	
COND	.37	1	.37	5.00	.027	

Duration of Voice Radio Transmissions--Battalion, Company and Platoon Nets						
Source of Variation	SS	DF	MS	F	Sig of F	
WITHIN CELLS	3.44	32	.11			
CONSTANT	447.04	1	447.04	4159.01	.000	
COND	1.05	1	1.05	9.81	.004	

Duration of Voice Radio Transmissions--Brigade Net						
Source of Variation	SS	DF	MS	F	Sig of F	
WITHIN CELLS	10.61	32	.33			
CONSTANT	474.35	1	474.35	1431.06	.000	
COND	1.08	1	1.08	3.25	.081	

Duration of Voice Radio Transmissions--Battalion O&I Net						
Source of Variation	SS	DF	MS	F	Sig of F	
WITHIN CELLS	13.34	30	.44			
CONSTANT	391.28	1	391.28	879.90	.000	
COND	.91	1	.91	2.06	.162	
Number of Voice Transmissions--Battalion Net						
Source of Variation	SS	DF	MS	F	Sig of F	
WITHIN CELLS	19505.41	32	609.54			
CONSTANT	509103.56	1	509103.56	835.22	.000	
COND	9556.03	1	9556.03	15.68	.000	
Number of Voice Transmissions--Company Net						
Source of Variation	SS	DF	MS	F	Sig of F	
WITHIN CELLS	23139.23	32	723.10			
CONSTANT	338270.54	1	338270.54	467.81	.000	
COND	1507.24	1	1507.24	2.08	.159	
Number of Voice Transmissions--Platoon Net						
Source of Variation	SS	DF	MS	F	Sig of F	
WITHIN CELLS	33411.06	32	1044.10			
CONSTANT	224167.06	1	224167.06	214.70	.000	
COND	12152.47	1	12152.47	11.64	.002	
Number of Voice Transmissions--Brigade Net						
Source of Variation	SS	DF	MS	F	Sig of F	
WITHIN CELLS	3302.26	32	103.20			
CONSTANT	21848.12	1	21848.12	211.72	.000	
COND	40.12	1	40.12	.39	.537	
Number of Voice Transmissions--Battalion O&I Net						
Source of Variation	SS	DF	MS	F	Sig of F	
WITHIN CELLS	8877.88	32	277.43			
CONSTANT	18285.89	1	18285.89	65.91	.000	
COND	5994.00	1	5994.00	21.61	.000	
Net Time on Voice Radio--Battalion Net						
Source of Variation	SS	DF	MS	F	Sig of F	
WITHIN CELLS	193.38	32	6.04			
CONSTANT	2451.24	1	2451.24	405.62	.000	
COND	59.52	1	59.52	9.85	.004	
Net Time on Voice Radio--Company Net						
Source of Variation	SS	DF	MS	F	Sig of F	
WITHIN CELLS	78.72	32	2.46			
CONSTANT	1135.86	1	1135.86	461.73	.000	
COND	13.63	1	13.63	5.54	.025	
Net Time on Voice Radio--Platoon Net						
Source of Variation	SS	DF	MS	F	Sig of F	
WITHIN CELLS	120.39	32	3.76			
CONSTANT	773.58	1	773.58	205.61	.000	
COND	65.00	1	65.00	17.28	.000	
Net Time on Voice Radio--Brigade Net						
Source of Variation	SS	DF	MS	F	Sig of F	
WITHIN CELLS	16.68	32	.52			
CONSTANT	87.73	1	87.73	168.34	.000	
COND	.91	1	.91	1.75	.195	
Net Time on Voice Radio--Battalion O&I Net						
Source of Variation	SS	DF	MS	F	Sig of F	
WITHIN CELLS	21.86	30	.73			
CONSTANT	60.13	1	60.13	82.51	.000	
COND	17.72	1	17.72	24.32	.000	

Number of Named Voice Reports--Battalion, Company and Platoon					
Source of Variation	SS	DF	MS	F	Sig of F
WITHIN CELLS	593.86	263	2.26		
CONSTANT	252.46	1	252.46	111.81	.000
COND	86.43	1	86.43	38.28	.000
ECHELON	42.88	2	21.44	9.49	.000
COND BY ECHELON	33.29	2	16.64	7.37	.001

Number of Named Voice Reports--Battalion, Company and Platoon--Simple Test					
Source of Variation	SS	DF	MS	F	Sig of F
WITHIN CELLS	723.13	266	2.72		
CONSTANT	321.50	1	321.50	118.26	.000
ECHELON(1)	58.95	1	58.95	21.69	.000
ECHELON(2)	21.98	1	21.98	8.08	.005

Number of Named Voice Reports--Battalion, Company and Platoon--Simple Effects Test					
Source of Variation	SS	DF	MS	F	Sig of F
WITHIN CELLS	593.86	263	2.26		
CONSTANT	252.46	1	252.46	111.81	.000
ECHELON	42.88	2	21.44	9.49	.000
COND W ECHELON(1)	1.00	1	1.00	.44	.506
COND W ECHELON(2)	86.05	1	86.05	38.11	.000
COND W ECHELON(3)	42.22	1	42.22	18.70	.000

## Appendix I

### Debrief Comments

Comments provided below were obtained from participants after they had completed the final test exercise for the Vertical Integration Evaluation (VIE). These debriefs were conducted in an MWTB classroom by the Battle Master. The purpose of this debrief was to provide noncomparative feedback on each test unit's performance during the test exercises and to obtain participants' comments and recommendations on their ability to meet the exercises' performance requirements, given their C<sup>3</sup> capabilities. Participants were released after completion of this debrief.

Comments are organized by the categories appearing in bold type. Comments are coded by test condition and test week, in parentheses, following each comment. Condition codes are C for CVCC, and B for Baseline. Test week codes are consecutively numbered test weeks, regardless of condition, and include Pilot (P) week comments. For example, (B/2) represents the Baseline condition debrief for the second evaluation week.

---

#### **TRAINING**

1. Bn Cdr said training was fine and objectives were clear. (B/P)
2. Bn Cdr said that, given equipment difficulties, things went pretty well. Requested more feedback from tactical side of the house, so that he may leave with something himself. There was training value in setting up reports and moving. (B/P)
3. Recommended a job aid for CCD; maybe a flip chart of some sort for reference. (A/6)

#### **REPORTS/RADIO NETS**

1. In reference to Bn Cmd net, Bn S3 said it was close to what you'd expect, but he didn't have a good idea of what was going on except with B Co. Didn't recall "abort attack" criteria. Reports still weren't what they should be (same for Horizontal Integration). (B/P)
2. Bn S3 said look at Battle Captain rather than Bn O&I net. This is what is used in Advanced Course now. (B/P)
3. Bn Cdr felt nets were at times hard to monitor, especially on the ALL position, because there was so much traffic (B/11)

#### **M1 SIMULATOR EQUIPMENT OTHER THAN RADIOS**

1. Need to have bumper numbers. (B/P)
2. To increase stress, take off kill suppress. (B/P)
3. Abilities of guns was poor, don't get as many hits as Simnet-T, pulls to the left. (B/2)
4. B06 said he generally left his CITV on Autoscan, spent most of time viewing CCD. (A/5)
5. Y06 viewed BN from CCD until contact and then used GLOS on CITV. (A/5)
6. B12 had throttle trouble; could not go faster than 20 km/hr; got behind rest of Bn for at least 1 VIE event (B/11)

### SAFOR (not report-related)

1. At the beginning of each exercise, the formation was not set up right. Wingman was in middle--had to move in formation. (B/P)

### CCD

1. There is a need for a multi-FLOT line to simulate real-life tanker abilities more closely (on SITREP). (A/3)
2. Increase nuclear cloud height (available input) to 4 digits to mimic real-life NBC possibilities. (A/3)
3. Intel report needs to have more than 1 enemy ID available to cite, eg., PC + MRC. (A/3)
4. Have "Obstacles" selection on Intel available on Spot reports. (A/3)
5. The average crewman will not use Intel, Contact, or Spot report formats. (A/3)
6. Need module to coordinate with Infantry, need them and Bradleys incorporated into Logistics. (A/3)
7. Need the ability to make FRAGO overlays, with axis of advance, smoke screens, reference points, etc. - disadvantage to have no graphic FRAGO overlay (could create with waypoints if necessary). (A/3)
8. Add "Moving" to enemy activity list on Spot. (A/3)
9. Need "number of" on Contact report - big difference between 1 vehicle and a company. (A/3)
10. Need "Continuing Mission" or "Movement to Contact" added to own activity list on Spot report. (A/3)
11. What numbers determine Green/Red/Amber/Black status in Logistics report? Would vary with mission in real life. (C/3)
12. Very difficult to read checkpoint - numbers are too small on CCD at any scale. (C/3)
13. Bn Cdr on Logistics - would prefer not to go back to original menu to get ammo, fuel, equipment reports separately. (C/3)
14. Bn Cdr on map scales - with 1:50,000 scale, cannot see enough of the battlefield to fight battalion level. (C/3)
15. Move CLR ALL from close proximity to SAVE on NAV screen. It's very easy to hit CLR ALL instead of SAVE when you're in a hurry. (C/4)
16. Tank commanders complained of slowness on CCD. (C/4)
17. Routes would not show up in RECEIVE Queue, went to OLD file directly or did not get it at all. (C/4)
18. Bn S3 and B Co Cdr misread the FRAGO because of how text was written. Thought PL JIM was MIKE. (C/4)

## CITV

1. Designate saved us during the helicopter attack. (C/3)
2. Bn Cdr said that when the enemy was very close, he should have used designate, but it was not automatic, not enough training yet. (C/4)
3. Used CITV for C<sup>2</sup>; used autoscan then waited for engagement, then scanned to the action. (C/6)

## TACTICS

1. When asked about how A and B Cos could have been better coordinated, B Co Cdr reported he thought A was B. (B/P)
2. Bn Cdr commented that withdrawal was unrealistic using all the CPs. Don't need them with graphics--took too much time. (B/P)
3. Bn S3 stated that more behavior needs to be realistic. Rambo-type behavior did go on. (B/P)
4. Bn S3 said that some briefings could be shorter. Never give an order out without an overlay in front of a soldier. Also, Bde graphics needed. (B/P)
5. General consensus was that navigation really wasn't a problem. They tended to follow SAFOR. Should set up so this can't be trusted. (B/P)
6. Today was too easy for command and control. (B/P)
7. In summarizing the Formative Evaluation, Bn Cdr stressed that command and control was realistic. (B/P)
8. Bn S3 suggested that we explain why they can't follow SAFOR--need accurate representation of abilities to test for difference between baseline and CVCC. (B/P)
9. B Co XO: Hard to get ranges, azimuths etc. for CFF, difficult to juggle map, etc., because can't see out. (B/2)
10. B11 strongly disagreed with the Battlemaster's comment that he should not have exposed his flank to the enemy, A Co XO thought it was the only reasonable way to exit the engagement. (B/2)
11. B11 complained that boundaries do not change in the real world. (B/2)
12. Bn Cdr thought that the FRAGOs had too many grids, hard to get them all. (B/2)
13. Troops suggested that they could have done better if they had worked together more. (B/2)
14. Hard to stay in formation with the limited vision in the simulator (C/6)
15. Drivers wanted bumper numbers on vehicles so they could maneuver better.(C/6)

## GENERAL

1. Bn S3 said OAC candidates would be best participants for us. (B/P)
2. TC felt it was hard to navigate; thought C<sup>2</sup> was good. (B/11)
3. Need better nav aids (a gyroscope). (B/12)

## APPENDIX J

### LIST OF ACRONYMS AND ABBREVIATIONS

<u>Acronym</u>	<u>Definition</u>
ANOVA	Analysis of Variance
ARPA	Advanced Research Projects Agency
ARI	U.S. Army Research Institute for the Behavioral and Social Sciences
BBN	Bolt Beranek and Newman Inc.
Bde	Brigade
BLUFOR	Blue (friendly) Forces
Bn	Battalion
BOS	Battlefield Operating System
C2	Command and Control
C3	Command, Control, and Communications
CCD	Command and Control Display
CECOM	U.S. Army Communications-Electronics Command
CFE	Call for Fire
CIG	Computer Image Generation
CITV	Commander's Independent Thermal Viewer
Cmd	Command
Co	Company
CO	Commanding Officer
CoM	Center of Mass
CSS	Combat Service Support
CVCC	Combat Vehicle Command and Control
DCA	Data Collection & Analysis System
DCD	Directorate of Combat Developments
DCE	Data Collection Exercise
ECR	Exercise Control Room
FBC	Future Battlefield Conditions
FLOT	Forward Line of Own Troops
FRAGO	Fragmentary Order
FSO	Fire Support Officer
GLOS	Gun Line of Sight
GPS	Gunner's Primary Sight
GPSE	Gunner's Primary Sight Extension
IVIS	Intervehicular Information System
LD	Line of Departure
LRF	Laser Range Finder
MCC	Management, Command and Control System
MOS	Military Occupational Specialty
MOU	Memorandum of Understanding

AcronymDefinition

MWTB	Mounted Warfare Test Bed
NBC	Nuclear, Biological, Chemical
NCO	Non-Commissioned Officer
NTC	National Training Center
O&I	Operations and Intelligence
OPFOR	Opposing Forces
OPORD	Operations Order
PL	Phase Line
POSNAV	Position Navigation
PVD	Plan View Display
RA	Research Assistant
REDCON	Readiness Condition
RIU	Radio Interface Unit
S2	Intelligence Officer
S3	Operations Staff Officer
SAFOR	Semiautomated Forces
SCC	SIMNET Control Console
SICPS	Standard Integrated Command Post System
SIMNET	Simulation Networking
SIMNET-D	Simulation Networking--Developmental
SINCGARS	Single Channel Ground and Airborne Radio System
SITREP	Situation Report
SME	Subject Matter Expert
SMI	Soldier-Machine Interface
SOP	Standing Operating Procedure
SPSS	Statistical Package for the Social Sciences
TACOM	U.S. Army Tank-Automotive Command
TIS	Thermal Imaging System
TOC	Tactical Operations Center
TRADOC	U.S. Army Training and Doctrine Command
TTPs	Tactics, Techniques, and Procedures
USAARMC	U.S. Army Armor Center
XO	Executive Officer