

REPORT DOCUMENTATION PAGE			Form Approved OMB No. 0704-0188	
Public reporting burden for this collection of information is estimated to average 1 hour per response, including the time for reviewing instructions, searching existing data sources, gathering and maintaining the data needed, and completing and reviewing the collection of information. Send comments regarding this burden estimate or any other aspect of this collection of information, including suggestions for reducing this burden, to Washington Headquarters Services, Directorate for Information Operations and Reports, 1215 Jefferson Davis Highway, Suite 1204, Arlington, VA 22202-4302, and to the Office of Management and Budget, Paperwork Reduction Project (0704-0188), Washington, DC 20503.				
1. AGENCY USE ONLY (Leave blank)	2. REPORT DATE 28Mar95	3. REPORT TYPE AND DATES COVERED Phase I SBIR Final Report May 1994 thru March 1995		
4. TITLE AND SUBTITLE Brush Seal Shaft Wear Resistant Coatings		5. FUNDING NUMBERS NAS3-27383		
6. AUTHOR(S) Harold Howe		7. PERFORMING ORGANIZATION NAME(S) AND ADDRESS(ES) Technetics Corporation 1600 Industrial Drive DeLand, FL 32724-2095		
8. PERFORMING ORGANIZATION REPORT NUMBER				
9. SPONSORING/MONITORING AGENCY NAME(S) AND ADDRESS(ES) NASA/U.S. Army NASA Lewis Research Center Research and Technology Branch 21000 Brookpark Road Cleveland, OH 44135-3191		10. SPONSORING/MONITORING AGENCY REPORT NUMBER Accession For NTIS CR&I DTIC TAB <input checked="" type="checkbox"/> Unannounced <input type="checkbox"/> Justification .....		
11. SUPPLEMENTARY NOTES Robert C. Hendricks Contracting Officer's Technical Representative		By _____ Distribution / _____ Availability Codes		
12a. DISTRIBUTION/AVAILABILITY STATEMENT Approved for public release; SBIR Report, distribution unlimited.		12b. DISTRIBUTION CODE Dist _____ Avail and/or Special _____ A-1		
13. ABSTRACT (Maximum 200 words) Brush seals suffer from high wear, which reduces their effectiveness. This work sought to reduce brush seal wear by identifying and testing several industry standard coatings. One of the coatings was developed for this work. It was a co-sprayed PSZ with boron-nitride added for a high temperature dry lubricant. Other coatings tested were a PSZ, chrome carbide and a bare rotor. Testing of these coatings included thermal shocking, tensile testing and wear/coefficient of friction testing. Wear testing consisted of applying a coating to a rotor and then running a sample tuft of SiC ceramic fiber against the coating. Surface speeds at point of contact were slightly over 1000 ft/sec. Rotor wear was noted, as well as coefficient of friction data. Results from the testing indicates that the oxide ceramic coatings cannot withstand the given set of conditions. Carbide coatings will not work because of the need for a metallic binder, which oxidizes in the high heat produced by friction. All work indicated a need for a coating that has a lubricant contained within itself and the coating must be resistant to an oxidizing environment.				
14. SUBJECT TERMS Brush Seal, Coating, Wear, Ceramic		15. NUMBER OF PAGES 37		16. PRICE CODE
17. SECURITY CLASSIFICATION OF REPORT Unclassified	18. SECURITY CLASSIFICATION OF THIS PAGE Unclassified	19. SECURITY CLASSIFICATION OF ABSTRACT Unclassified	20. LIMITATION OF ABSTRACT UL	

DTIC  
 SELECTED  
 APR 04 1995  
 G

19950403 092

## INTRODUCTION AND BACKGROUND

Brush seals are currently being used for replacement of labyrinth type shaft seals, since brush seals provide better leakage characteristics. Brush seals also allow for shaft dynamics or shaft excursions. When a labyrinth seal experiences a shaft excursion, a permanent groove or scar is left in the seal. The presence of a scar on the labyrinth will allow additional leakage, which with time will continue to degrade the seal's effectiveness. A brush seal will bend with the excursion and then return to its original configuration and leakage characteristics. The bristles ride or rest on the shaft of a rotating member, creating the sealing or flow restriction that makes the brush seal a better seal. As the shaft rotates, a tribological problem arises between the bristles and the shaft. Frictional heating of the bristle causes, or at least increases, the oxidation of the bristle alloy and increases wear of the fiber. The net effect of this is to decrease the brush seals' effectiveness. When a brush seal is initially installed, an interference condition is intentionally created. The clearance between the shaft and the bristles is typically  $-.010$  inches, but after only a few hours of operation the bristles have worn to a zero clearance fit. Bristle wear is caused by frictional heating and related oxidation, which then chips off. In an attempt to alleviate wear, ceramic bristle brush seals are being investigated. Ceramics are well known for their favorable temperature and wear characteristics. A ceramic fiber will allow the bristle to maintain the interference fit for a longer time. With the fibers intimate contact with the shaft, greater brush seal performance can be taken advantage of, for a much longer time. It is known that the greater the contact pressure of the bristles on the shaft, the greater the leakage resistance of the brush seal. This tendency of brush seals has been documented by several sources. For this reason, it is desirable that the bristles maintain their interference fit with the shaft over the life of the seal.

Since it has been shown that a brush seal can be made with ceramic fibers (thereby producing a prolonged intimate contact between bristle and shaft), the next logical system member for improvement is the shaft. Most current applications and test programs utilize some type of shaft coating for the bristle to slide against. There are two main reasons for this. The first is to eliminate damage that the brush may do to a bare shaft. For safety reasons, it is better that the seal wear, rather than the shaft. The second, is to provide a smoother surface for the bristle to ride on, so as to prolong the seal's life. To reduce wear, the coatings are usually required to have a  $10\mu$  in. Ra or better finish. The polished finish reduces the friction coefficient, thereby reducing wear. While this does prolong the intimate contact, the usual time required to produce a line-to-line or zero clearance fit is still in the tens of hours. It is acknowledged that even at line-to-line contact a brush seal still reduces leakage substantially better than a labyrinth but with an interference fit, a brush seal can even do better. Figure 1 is the

# TECHNETICS TEST RIG

2450/36/.003

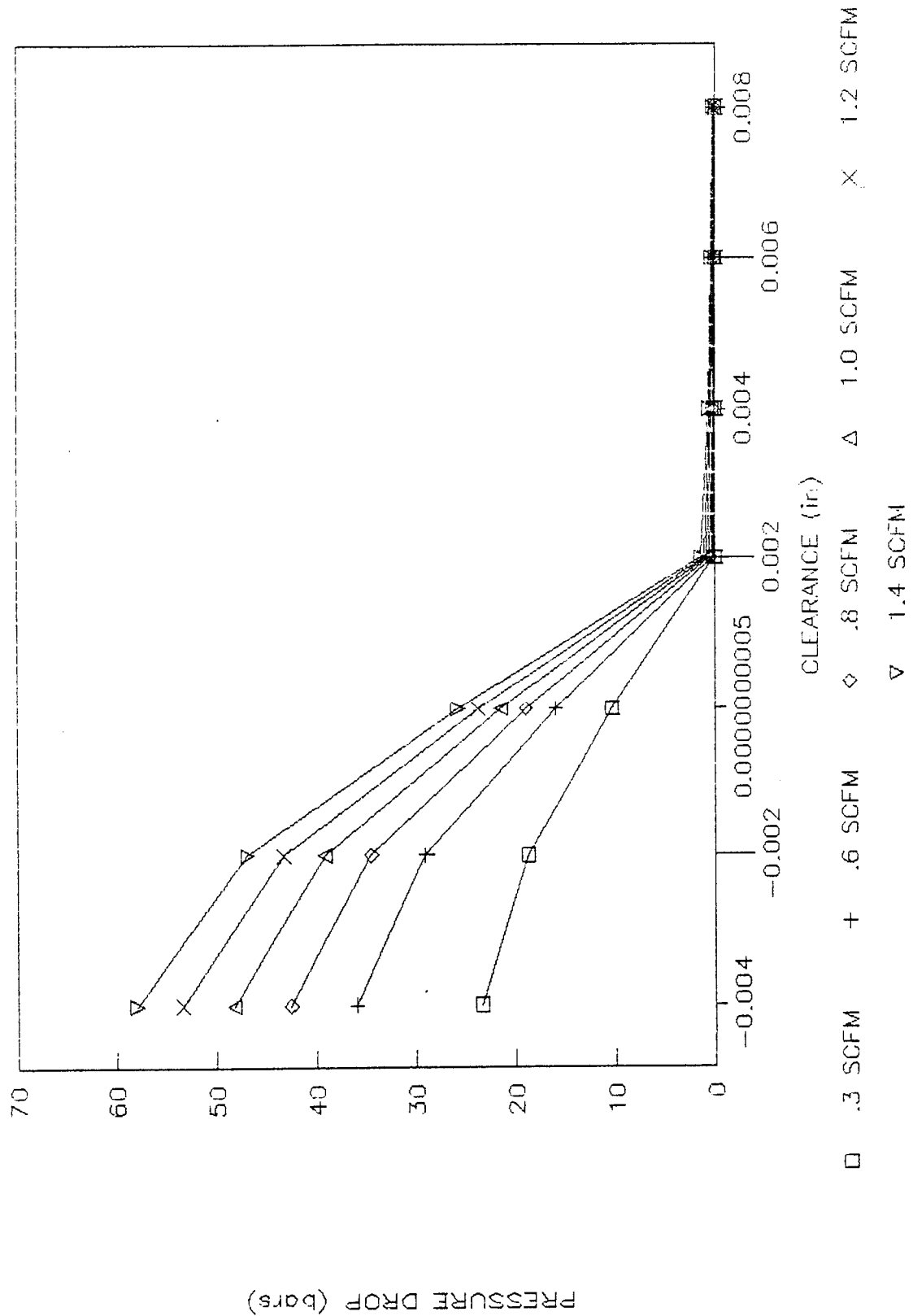

Figure 1  
Typical Graph of Predicted Brush Seal Performance

predicted leakage of a typical brush seal on a circumferential inch basis. It is seen that the seal's performance drops off sharply with a clearance increase between the seal's bristles and the shaft - evidencing the performance advantages that could be realized if a bristle and coating can be developed to retain an interference fit.

#### TECHNICAL OBJECTIVES

The technical objectives of this work were:

1. Identify candidate coatings
2. Identify and/or develop coating application methods
3. Screen coatings and application methods

In the identification of candidate coatings, coefficients of friction, wear, temperature and capabilities/properties were considered - to find the best available state of the art coatings which may compliment the brush seal system. Coatings that were examined are industry standard coatings and variants thereof.

Experimental work indicates that the wear of a ceramic can be attributed, in part, to its porosity. More porosity produces more wear. For this reason coating application methods were sought, which would produce a low porosity structure. It has also been demonstrated that ceramics with a softer second phase around the grain boundaries may also reduce wear. A coating, produced by co-spraying two materials to produce a soft second phase, was evaluated. It was believed that a co-sprayed coating of zirconia and boron nitride could produce a softer second phase surrounding hard primary phase grains, thus producing a dry lubricated coating with good potential.

Screening of the coatings and application methods was based on properties and characteristics known to be necessary for a low wear tribological system. Considered candidate coatings must have had at least some favorable properties that fit the goals of this effort. For this reason, a literature search, as well as discussions with industry leaders in coatings, was completed prior to choosing coatings for testing. Screening proceeded with temperature, oxidation, thermal shock, wear and friction testing.

#### WEAR TESTING

Wear testing consisted of placing a prepared tuft of fiber in contact with a high speed rotating rotor on which a coating had been applied. Figure 2 shows a simplified view of the test apparatus. The rig is powered by a 15 hp air turbine capable of speeds up to 50,000 rpm. For purposes of these tests, a heavier 6 inch diameter rotor was employed and rotational speeds were held to a maximum of 40,000 rpm. The tuft holder is attached to an air bearing to minimize any frictional error. A moment arm is

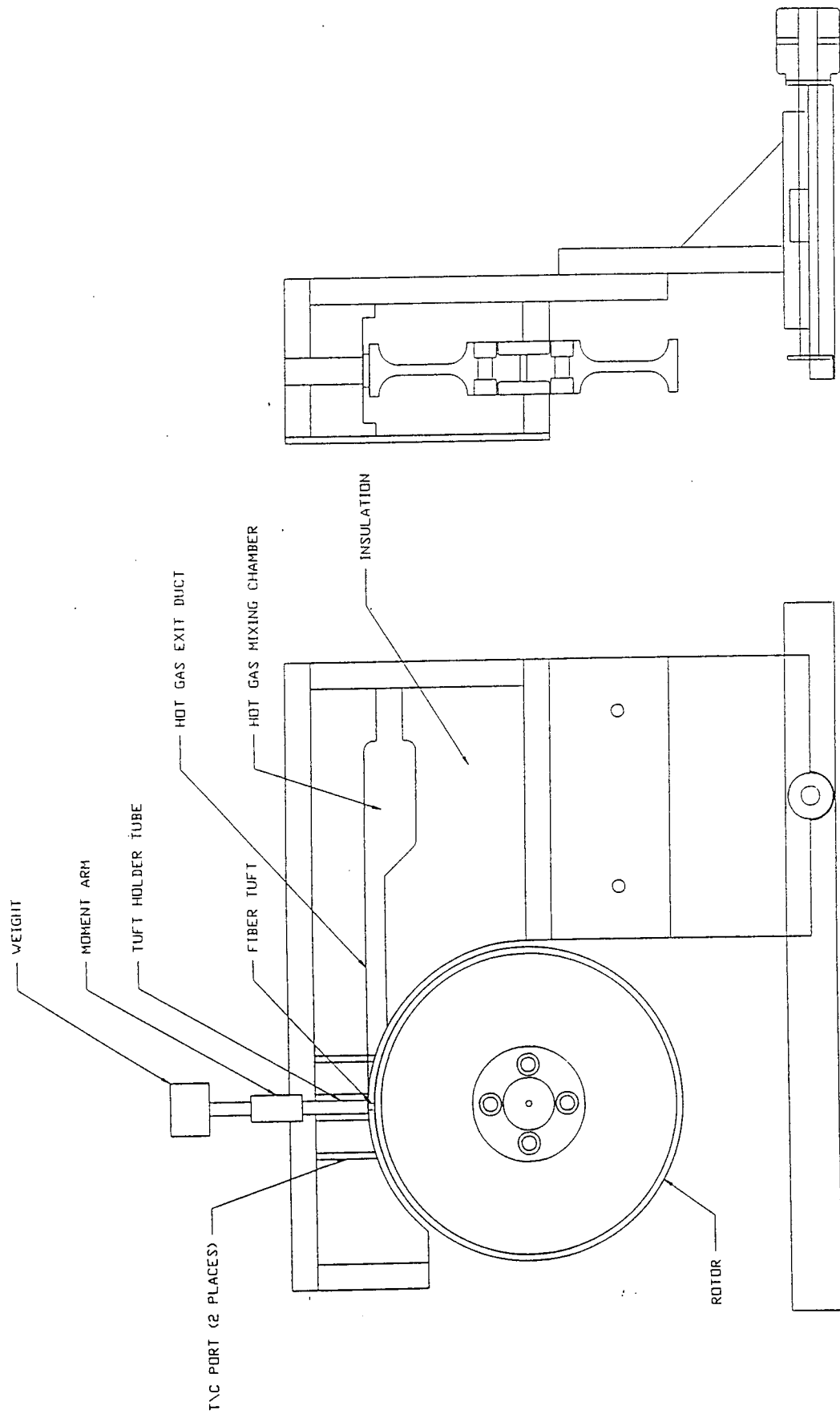

SECTION VIEWS OF FIBER / COATING TEST RIG

Figure 2

projected off the air bearing shaft and rests on a one pound load cell. By adjusting the load cells position in relation to the axis of the air bearing, the load sensitivity can be adjusted. Additional test points were temperatures taken by thermocouples placed for and aft of the tuft/rotor contact point.

Prior to testing, a rotor was prepared by applying and polishing a coating. A super finishing process was used for polishing. Surface finishes were 10 Ra or below, when possible. After polishing, rotors were mounted on the air turbine and dynamically balanced. Rotors were balanced to below 0.00002 inches peak to peak vibration. Tufts were prepared by placing approximately 350 SiC fibers of 0.006 inch diameter into a ceramic tube and fixing the fibers with ceramic cement. At least 0.75 inches of fiber was left protruding from the tube and was used for, or consumed in testing. Similar tuft samples were also made from Haynes 25 fiber.

Testing began by bringing the rotor up to speed and letting it stabilize. Base readings for temperature and drag load were then taken. A fiber tuft was applied with a dead load, normal to a tangent line from the rotor with the tuft axis directly over the center of the rotor. Three sets of readings were taken. Initial readings were taken right after application of the tuft. The second reading was taken at 3 minutes. A final set of readings was then taken at the conclusion of the test after a total of six minutes of fiber to coating/rotor contact. Tuft wear measurements were taken prior to increasing the dead load. Combination of 3 weights and 3 speeds were made to develop the test matrix. Figure 3 shows the test matrix.

#### THERMAL SHOCK TESTING

A coupon with coating material applied was thermally shocked for 2,178 cycles to determine if thermal cycling would cause the coatings to crack. A coupon consists of a superalloy sheet metal rectangle one inch by three inches. It is rolled to a convex contour. The coupon is then fixtured next to the rotor during coating application. Testing of these coupons consisted of simultaneously heating the coating surface to 2000°F while cooling the back side with a 150 SCFH air jet. The coupon is then quenched with a 150 SCFH air jet on the coating side. Each cycle lasts 90 seconds. Periodic examinations are made for sampled degradation.

#### COATINGS

Six coatings were chosen for testing. Chosen coatings were all thought to have desirable characteristics for a ceramic brush seal application.

1. Chrome Carbide - This coating was supplied by General Plasma and is their coating GPX-2176HP. Composition is 75% chromium carbide and 25% 80 nickel/20 chromium. It is applied by plasma flame spray. This and similar

Figure 3

## Test Matrix

# TUFT TESTING

REPEATABILITY STUDY

03/28/95

## BN/PSZ COATED ROTOR

		S20	M20	L20	S30	M30	L30	S40	M40	L40
		TRAC/PN	TRAC/PN	TRAC/PN	TRAC/PN	TRAC/PN	TRAC/PN	TRAC/PN	TRAC/PN	TRAC/PN
SiC Fibers	AMB	9A/038	9A/038	9A/038	9A/038	9A/039	9A/039	9A/040	9A/040	DISC
SiC Fibers	AMB	9A/038	9A/038	9A/038	9A/039	9A/039	9A/039	9A/040	9A/040	DISC
SiC Fibers	AMB	9A/038	9A/038	9A/038	9A/039	9A/039	DISC	9A/040	9A/040	DISC
SiC Fibers	AMB	9A/038	9A/038	9A/038	9A/039	9A/039	DISC	9A/040	9A/040	DISC
SiC Fibers	COLD	9B/041	9B/041	9B/041	9B/042	9B/042	9B/042	9B/043	9B/043	9B/044
SiC Fibers	COLD	9B/041	9B/041	9B/041	9B/042	9B/042	9B/042	9B/043	9B/043	9B/044
SiC Fibers	COLD	9B/041	9B/041	9B/042	9B/042	9B/042	9B/043	9B/043	9B/043	9B/044
SiC Fibers	COLD	9B/041	9B/041	9B/042	9B/042	9B/042	9B/043	9B/043	9B/043	9B/044

## PSZ COATED ROTOR

SiC Fibers	AMB	8A/036	8A/036	8A/036	8B/037	8B/037	8B/037	8C/037	8C/037	DISC
SiC Fibers	AMB	8A/036	8A/036	8A/036	8B/037	8B/037	8B/037	8C/037	8C/037	DISC
SiC Fibers	AMB	8A/036	8A/036	8A/036	8B/037	8B/037	8B/037	8C/037	8C/037	DISC
SiC Fibers	AMB	8A/036	8A/036	8A/036	8B/037	8B/037	8B/037	8C/037	8C/037	DISC

## CHROME CARBIDE COATED ROTOR

SiC Fibers	AMB	7A/019	7A/019	7A/019	7A/019	7A/019	7A/019	7A/020	7A/020	7A/020
SiC Fibers	AMB	7A/019	7A/019	7A/019	7A/019	7A/019	7A/019	7A/020	7A/020	7A/020
SiC Fibers	AMB	7A/019	7A/019	7A/019	7A/019	7A/019	7A/019	7A/020	7A/020	7A/020
SiC Fibers	AMB	7A/019	7A/019	7A/019	7A/019	7A/019	7A/019	7A/020	7A/020	7A/020
SiC Fibers	COLD	7B/025	7B/025	7B/025	7B/025	7B/025	7B/025	7B/025	7B/025	7B/025
SiC Fibers	COLD	7B/025	7B/025	7B/025	7B/025	7B/025	7B/025	7B/025	7B/025	7B/035
SiC Fibers	COLD	7B/025	7B/025	7B/025	7B/025	7B/025	7B/025	7B/025	7B/025	7B/035
SiC Fibers	COLD	7B/025	7B/025	7B/025	7B/025	7B/025	7B/025	7B/025	7B/025	7B/035

## BARE ROTOR - NO COATING

SiC Fibers	AMB	10A/050	10A/050	10A/050	10A/050	10A/050	10A/050	10A/050	10A/050	10A/051
SiC Fibers	AMB	10A/050	10A/050	10A/050	10A/050	10A/050	10A/050	10A/050	10A/051	10A/051
SiC Fibers	AMB	10A/050	10A/050	10A/050	10A/050	10A/050	10A/050	10A/050	10A/051	10A/051
SiC Fibers	AMB	10A/050	10A/050	10A/050	10A/050	10A/050	10A/050	10A/050	10A/051	10A/051

## BARE ROTOR - NO COATING

H25 Fibers	AMB	10B/052	10B/052	10B/052	10B/052	10B/052	10B/052	10B/052	10B/052	10B/053
H25 Fibers	AMB	10B/052	10B/052	10B/052	10B/052	10B/052	10B/052	10B/052	10B/052	10B/053
H25 Fibers	AMB	10B/052	10B/052	10B/052	10B/052	10B/052	10B/052	10B/052	10B/052	10B/053
H25 Fibers	AMB	10B/052	10B/052	10B/052	10B/052	10B/052	10B/052	10B/052	10B/052	10B/053

WEIGHTS  
S - SMALL  
M - MEDIUM  
L - LARGE

RPM'S  
20 - 20,000  
30 - 30,000  
40 - 40,000

COMPLETED  
AMBIENT - NO AIR FLOW  
COLD - 7.5 SCFM

DISC - DISCONTINUED  
SiC - SILICON CARBIDE FIBER  
H25 - HAYNES 25 FIBER

EXAMPLE: 1A/001 - ROTOR:1 ; TRACK:A ; TUFT:001

coatings are the current coatings of choice for metallic brush seal applications. The coating proved very hard and dense. These attributes enabled the coating to be polished to a finish of less than one micro inch Ra.

2. Boron Nitride filled PSZ - A plasma co-sprayed mixture of boron nitride and yttria stabilized zirconia was developed for this program in an effort to provide an oxide coating with a dry high temperature lubricant additive. It was known that a two phase system composed of a hard primary phase and a soft secondary phase would produce a coating resistant to crack propagation. It is also known that boron nitride can provide a high temperature lubricant. These two characteristics are believed to be necessary for a successful ceramic brush seal coating.
3. Partially Stabilized Zirconia - A plasma sprayed yttria stabilized zirconia was chosen for its fracture toughness and the non-stick or slick properties of zirconia. Zirconia has a high coefficient of thermal expansion so it lends itself well to the direct application onto metals. Ytterbia stabilized ceramics are known for their fracture toughness. These characteristics would eliminate the cracking and high wear situation seen in alumina coatings.
4. Partially Stabilized Zirconia - A vapor deposited PSZ was chosen for its high density and previously noted properties. This coating was the highest density of all coatings chosen. This coating was not available at the time of testing, due to coating application problems. The coating was incompatible with the high expansion rotor material. Bond coat failures on two attempts precluded any further testing.
5. Alumina - A HVOF applied alumina coating was chosen for its high density and oxidation resistance. This coating was not available at the time of testing.
6. Triboglide® - This coating is known for its high temperature, self-lubricating properties. It has been tested extensively for bearing applications and initial testing for application with metallic brush seals has shown excellent results. This coating was not available at the time of testing.

## RESULTS

Raw wear data with calculated values and plotted data are provided in Appendix A. Thermal shock testing was done on the oxide ceramic coatings to determine if thermal growth or shock would cause cracking or spallation. All passed 2,178 cycles

without one crack or spallation. Ultimate tensile strength testing of the oxide ceramic coatings had similar results in that all coatings exceeded the minimum tensile strengths for test conditions.

Wear testing was the primary objective of this program and generated the most applicable data for ceramic brush seals. The chrome carbide coating suffered the most damage. After only a few minutes of testing, the SiC fiber tufts wore through the .006-.007" thick coating. It is believed that the metal matrix oxidized away and the carbide particles were then free to fall off. Metal matrixes or bonding agents cannot withstand the high temperatures created by friction between the ceramic bristles and the coating, even after the coating has been polished to a mirror finish.

The oxide ceramic coatings did not fair much better than the chrome carbide. Life was about tripled, but deep scars appeared after only a relatively short time. The condition of dry unlubricated sliding friction between two hard ceramics produced high wear.

Bare or uncoated rotors made of 17-4PH proved to be the most wear tolerant material tested. It is believed that the 17-4PH smeared rather than fractured off, like the harder more brittle ceramics. Wear caused by oxidation of the metal was probably reduced because of the metals' greater thermal conductivity, absorbing and conducting away the frictional heat. Low total test time also contributed to the lack of oxidation wear.

#### CONCLUSION

No coating tested would be suitable for a rotating ceramic brush seal application. Wear was too high in all cases. However, bare uncoated metallic surfaces with 100% densities could prove to be good applications for low speed and low temperature ceramic brush seals. Investigation of coatings containing lubricants must be tested to see if they can provide the needed low wear additive required for an increase in brush seal performance.

APPENDIX

# TUFT TESTING RESULTS

## BN/PSZ COATED ROTOR

### AMBIENT AIR TESTING

PART #9 TRAC A  
 TUFT 038 START THRU L30(I1S1)  
 TUFT 039 L30(2ND) THRU L30(4TH)  
 TUFT 040 S40 THRU THE END  
 FIBER/TEST

FIBER/TEST	TEMP (°F)		IC2(°F)		TEMP (°F)		IC3(°F)		START IC3(°F)		CHANGE (°F)		START DL	DL CHANGE	START IF1 WT(q)	END IF1 WT(q)	LOSS(q)	WT DRAG (lb)	N (lb)	CF
	END	START	END	START	END	START	END	START	END	DL	DL	DL								
SiC/S20/AMB	116.2	74.7	41.5	110.3	78.7	31.6	0.216	0.006	0.210	13.1688	13.1572	0.0116	0.4259	0.3913	1.0884					
	115.5	95.3	20.2	105.8	84.3	21.5	0.227	0.004	0.229	13.1554	13.1554	0.0018	0.4522	0.3913	1.1558					
	126.7	102.0	24.7	112.1	87.8	24.3	0.266	0.007	0.253	13.1554	13.1516	0.0038	0.5253	0.3913	1.3424					
	129.6	101.2	28.4	110.6	85.2	25.4	0.246	0.005	0.241	13.1516	13.1489	0.0027	0.4887	0.3913	1.2491					
SiC/M20/AMB	129.7	104.2	25.5	109.0	86.2	21.8	0.241	0.007	0.234	13.1489	13.1436	0.0053	0.4746	0.6017	0.7887					
	126.0	107.3	16.7	106.5	86.7	19.8	0.239	0.006	0.233	13.1436	13.1393	0.0043	0.4725	0.6017	0.7853					
	128.0	101.7	26.3	107.8	84.1	23.7	0.246	0.004	0.242	13.1393	13.1358	0.0035	0.4908	0.6017	0.8157					
	128.5	105.4	23.1	109.2	86.4	22.8	0.266	0.006	0.260	13.1358	13.1289	0.0069	0.5273	0.6017	0.8764					
SiC/L20/AMB	142.2	71.7	70.5	124.0	76.9	47.1	0.369	0.007	0.362	13.1289	13.0977	0.0312	0.7341	1.1172	0.6571					
	127.2	110.3	16.9	112.0	86.6	25.4	0.289	0.006	0.283	13.0977	13.0838	0.0139	0.5739	1.1171	0.5137					
	122.8	103.6	19.2	112.8	86.0	26.8	0.284	0.009	0.275	13.0838	13.0660	0.0178	0.5577	1.1171	0.4992					
	122.9	104.2	18.7	113.6	86.6	27.0	0.307	0.006	0.301	13.0660	13.0444	0.0216	0.6104	1.1171	0.5465					
SiC/S30/AMB	112.7	102.7	10.0	105.0	96.0	9.0	0.090	0.004	0.086	13.0444	13.0400	0.0044	0.1744	0.3910	0.4460					
	111.1	101.9	9.2	104.9	96.8	8.1	0.086	0.003	0.083	13.0400	13.0378	0.0022	0.1683	0.3910	0.4305					
	110.2	102.4	7.8	104.6	96.9	7.7	0.085	0.005	0.080	13.0378	13.0362	0.0016	0.1622	0.3910	0.4149					
	112.3	101.0	11.3	106.0	96.8	9.2	0.096	0.005	0.091	13.0362	13.0340	0.0022	0.1845	0.3910	0.4720					
SiC/M30/AMB	118.7	101.8	16.9	111.5	96.9	14.6	0.135	0.007	0.128	13.0340	13.0281	0.0059	0.2596	0.6014	0.4031					
	119.4	106.9	12.5	111.6	98.9	12.7	0.130	0.006	0.124	13.0281	13.0205	0.0076	0.2515	0.6014	0.4181					
	117.3	106.4	10.9	110.0	98.0	12.0	0.123	0.003	0.120	13.0205	13.0130	0.0075	0.2434	0.6014	0.4047					
	116.8	104.8	12.0	109.8	97.4	12.4	0.119	0.006	0.113	13.0130	13.0060	0.0070	0.2292	0.6014	0.3811					
SiC/L30/AMB	129.5	104.2	25.3	124.0	97.0	27.0	0.226	0.004	0.222	13.0060	12.9580	0.0480	0.4502	1.1169	0.4031					
	123.5	67.8	55.7	120.1	83.9	36.2	0.258	0.007	0.251	12.9372	12.8987	0.0385	0.5090	1.1167	0.4558					
	121.6	104.9	16.7	118.1	88.5	29.6	0.239	0.006	0.233	12.8987	12.8432	0.0555	0.4725	1.1166	0.4232					
	DISC	DISC	DISC	DISC	DISC	DISC	DISC	DISC	DISC	DISC	DISC	DISC	DISC	DISC	DISC					
SiC/S40/AMB	114.9	99.1	15.8	108.5	107.8	0.7	0.092	0.006	0.086	13.7246	13.6955	0.0291	0.1744	0.3925	0.4444					
	117.0	105.5	11.5	107.9	101.5	6.4	0.114	0.006	0.108	13.6955	13.6891	0.0064	0.2190	0.3925	0.5581					
	117.2	104.8	12.4	110.1	101.7	8.4	0.102	0.008	0.094	13.6891	13.6840	0.0051	0.1906	0.3925	0.4857					
	124.1	106.3	17.8	110.2	104.1	6.1	0.115	0.010	0.105	13.6840	13.6781	0.0059	0.2129	0.3924	0.5426					
SiC/M40/AMB	123.7	107.0	16.7	113.7	102.2	11.5	0.155	0.006	0.149	13.6781	13.6654	0.0127	0.3022	0.6028	0.5013					
	121.2	110.2	11.0	111.5	101.6	9.9	0.140	0.006	0.134	13.6654	13.6498	0.0156	0.2716	0.6028	0.4508					
	123.1	108.4	14.7	115.3	104.0	11.3	0.160	0.008	0.152	13.6498	13.6356	0.0142	0.3083	0.6028	0.5114					
	121.1	109.8	11.3	114.1	105.0	9.1	0.135	0.010	0.125	13.6356	13.6240	0.0119	0.2535	0.6027	0.4206					
SiC/L40/AMB	DISC	DISC	DISC	DISC	DISC	DISC	DISC	DISC	DISC	DISC	DISC	DISC	DISC	DISC	DISC					
	DISC	DISC	DISC	DISC	DISC	DISC	DISC	DISC	DISC	DISC	DISC	DISC	DISC	DISC	DISC					
	DISC	DISC	DISC	DISC	DISC	DISC	DISC	DISC	DISC	DISC	DISC	DISC	DISC	DISC	DISC					
	DISC	DISC	DISC	DISC	DISC	DISC	DISC	DISC	DISC	DISC	DISC	DISC	DISC	DISC	DISC					

NOTES:  
 IC2 -- Thermocouple located after the tuft slightly above the rotor.  
 IC3 -- Thermocouple located before the tuft slightly above the rotor.  
 DL -- Drag Load (lbs @ 6.085 in. radius)

SIC -- Silicon Carbide Fibers

20 -- 20,000 RPM's  
 30 -- 30,000 RPM's  
 40 -- 40,000 RPM's

\*\*\* -- Test Failure

AMB -- Ambient Air (no flow)

S -- Small Weight 164.30g  
 M -- Medium Weight 259.73g  
 L -- Large Weight 493.56g

CF -- Coefficient of Friction

# SiC on BN/PSZ

Ambient Air / Small Wt.

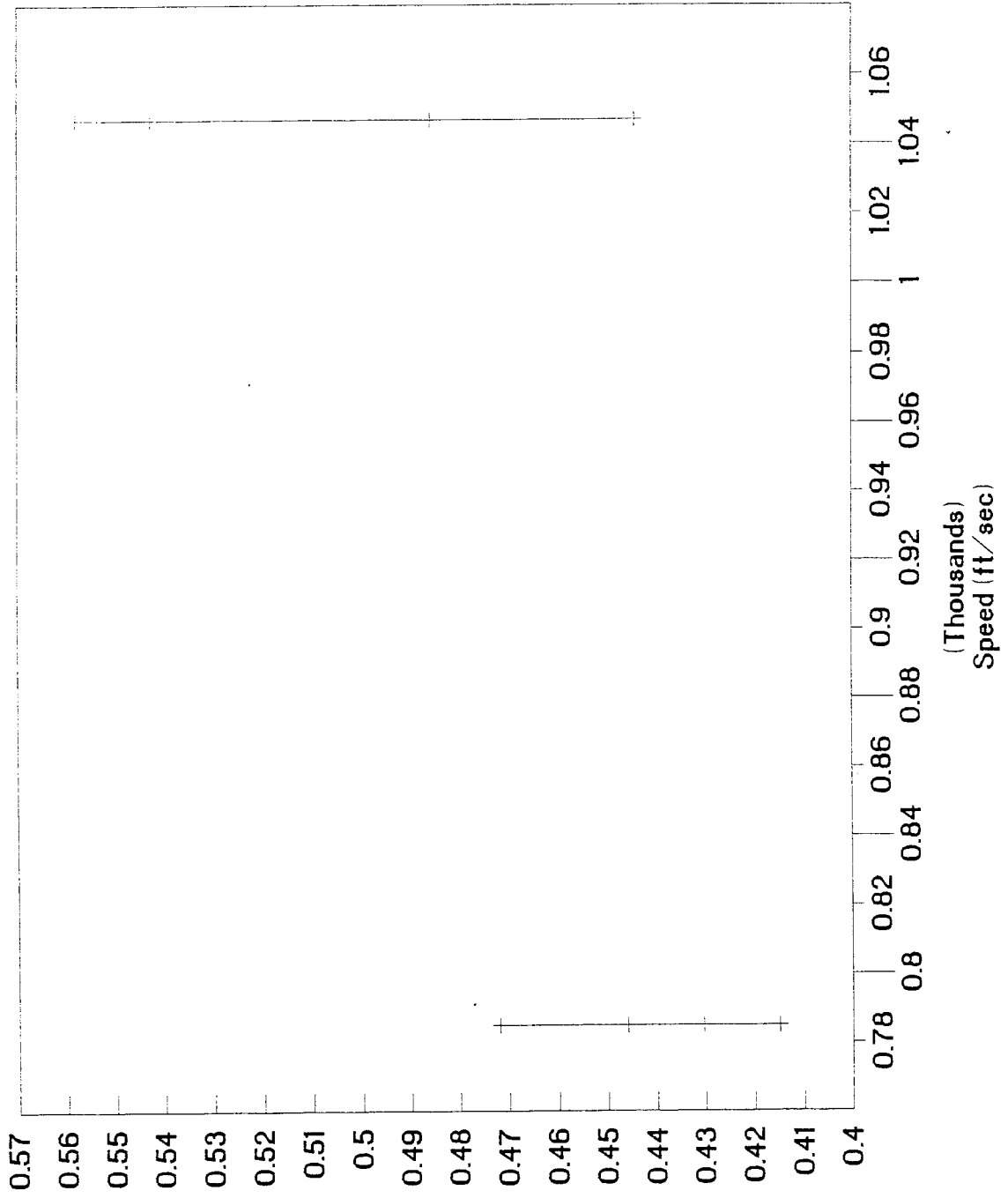

# SiC on BN/PSZ

Ambient Air / Medium Wt.

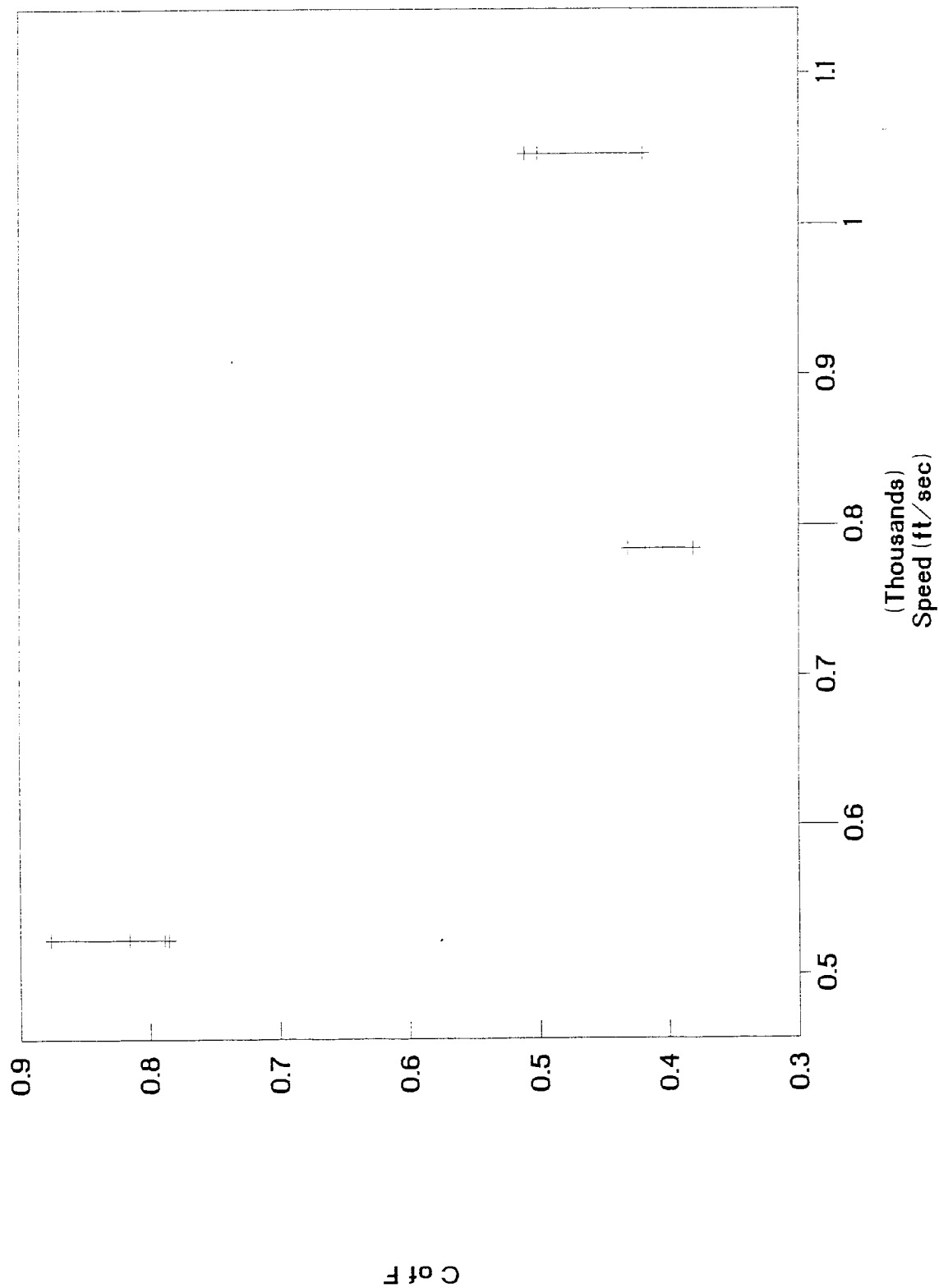

# SiC on BN/PSZ

Ambient Air / Large Wt.

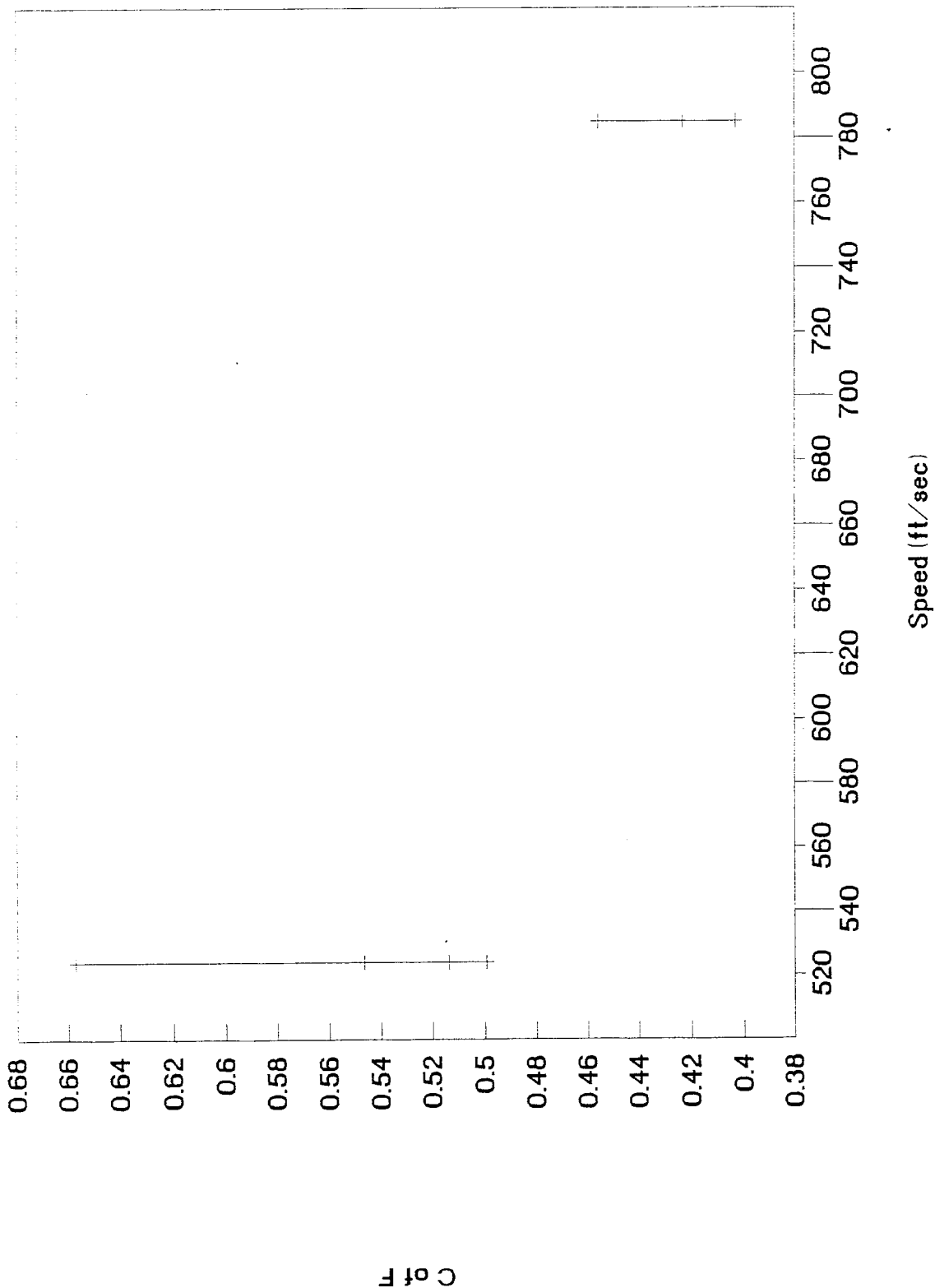

# TUFT TESTING RESULTS

BN/PSZ COATED ROTOR

COLD AIR TESTING

PART #9 TRAC B  
 TUFT PART #041 START THRU L20(2ND)  
 TUFT PART #042 THRU L30(2ND)  
 TUFT PART #043 THRU M40  
 TUFT PART #044 REMAINDER

FIBER/TEST	TEMP		START TC2(F)	START TC3(F)	TEMP CHANGE(F)	END TC3(F)	END DL	START DL	DL CHANGE	START IF WT(g)	END IF WT(g)	LOSS(g)	WT DRAG (lb)	N (lb)	CF
	END TC2(F)	CHANGE(F)													
SiC/S20/CLD	77.6	11.1	64.7	64.7	0.3	65.0	0.176	0.007	0.169	13.1143	13.1125	0.0018	0.3427	0.3912	0.8761
	78.6	10.2	64.8	64.8	0.5	65.3	0.177	0.009	0.168	13.0780	13.0755	0.0025	0.3407	0.3911	0.8711
	69.4	10.1	55.1	55.1	-1.7	53.4	0.162	0.007	0.155	13.0755	13.0734	0.0021	0.3143	0.3911	0.8037
	70.2	6.6	52.9	52.9	-1.1	51.8	0.179	0.010	0.169	13.0734	13.0718	0.0016	0.3427	0.3911	0.8763
	69.4	5.5	51.7	51.7	-0.3	51.4	0.182	0.008	0.174	13.0718	13.0686	0.0032	0.3529	0.6015	0.5866
SiC/M20/CLD	69.6	7.6	50.5	50.5	-0.3	50.2	0.165	0.008	0.157	13.0686	13.0646	0.0040	0.3184	0.6015	0.5293
	68.0	5.1	49.7	49.7	-0.3	49.7	0.159	0.007	0.152	13.0646	13.0627	0.0019	0.3083	0.6015	0.5125
	68.3	7.1	49.6	49.6	-0.4	49.2	0.154	0.009	0.145	13.0627	13.0598	0.0029	0.2941	0.6015	0.4889
	72.0	11.6	48.9	48.9	0.5	49.4	0.248	0.007	0.241	13.0598	13.0589	0.0209	0.4887	1.1171	0.4375
	71.9	7.9	48.9	48.9	0.4	49.3	0.269	0.007	0.262	13.0589	13.0154	0.0235	0.5313	1.1170	0.4757
SiC/L20/CLD	75.0	16.2	48.4	48.4	0.9	49.3	0.287	0.008	0.279	13.3645	13.3489	0.0156	0.5658	1.1177	0.5062
	77.3	11.5	48.9	48.9	0.7	49.6	0.289	0.010	0.279	13.3489	13.3317	0.0172	0.5658	1.1177	0.5062
	79.9	16.6	49.6	49.6	0.5	50.1	0.123	0.008	0.115	13.3317	13.3313	0.0004	0.2332	0.3917	0.5954
	78.8	22.5	50.7	50.7	0.7	51.4	0.101	0.005	0.096	13.3313	13.3300	0.0013	0.1947	0.3917	0.4971
	78.7	9.6	51.2	51.2	0.3	51.5	0.100	0.007	0.093	13.3300	13.3292	0.0008	0.1886	0.3917	0.4815
SiC/M30/CLD	84.2	13.8	51.5	51.5	0.7	52.2	0.129	0.006	0.123	13.3262	13.3200	0.0062	0.2494	0.6021	0.4143
	83.8	12.1	52.1	52.1	0.5	52.6	0.126	0.006	0.120	13.3200	13.3151	0.0049	0.2434	0.6021	0.4042
	85.1	12.2	52.6	52.6	0.2	52.8	0.147	0.006	0.141	13.3151	13.3102	0.0049	0.2859	0.6021	0.4750
	85.6	12.1	52.4	52.4	0.6	53.0	0.139	0.008	0.131	13.3102	13.3041	0.0061	0.2657	0.6020	0.4413
	93.0	19.2	52.8	52.8	0.9	53.7	0.229	0.006	0.223	13.3041	13.2690	0.0351	0.4522	1.1176	0.4047
SiC/L30/CLD	92.9	16.1	53.0	53.0	0.8	53.8	0.249	0.010	0.239	13.2690	13.2294	0.0396	0.4847	1.1175	0.4337
	99.0	27.1	52.8	52.8	1.6	54.4	0.252	0.007	0.245	13.2495	13.2151	0.0344	0.4969	1.1174	0.4446
	96.6	15.6	53.9	53.9	0.7	54.6	0.252	0.007	0.245	13.2151	13.1711	0.0440	0.4969	1.1173	0.4447
	92.3	12.9	54.3	54.3	0.4	54.7	0.091	0.006	0.085	13.1711	13.1643	0.0069	0.1724	0.3913	0.4405
	91.4	8.6	54.8	54.8	0.4	55.2	0.095	0.007	0.088	13.1643	13.1592	0.0051	0.1785	0.3913	0.4561
SiC/M40/CLD	87.8	5.4	55.4	55.4	-0.4	55.0	0.098	0.007	0.091	13.1592	13.1551	0.0041	0.1845	0.3913	0.4716
	81.0	1.7	54.8	54.8	-0.1	54.7	0.097	0.007	0.090	13.1551	13.1525	0.0026	0.1825	0.3913	0.4665
	97.8	33.5	55.6	55.6	1.4	57.0	0.128	0.009	0.119	13.1525	13.1400	0.0125	0.2413	0.6017	0.4011
	98.4	10.8	57.0	57.0	0.4	57.4	0.133	0.009	0.124	13.1400	13.1285	0.0115	0.2515	0.6017	0.4180
	95.2	7.8	57.5	57.5	0.1	57.6	0.148	0.009	0.139	13.1285	13.1154	0.0131	0.2819	0.6016	0.4886
SiC/M40/CLD	94.2	8.9	57.3	57.3	0.4	57.7	0.169	0.007	0.162	13.1154	13.0960	0.0194	0.3285	0.6016	0.5461
	101.5	25.1	57.5	57.5	0.7	58.2	0.259	0.009	0.250	13.3562	13.3193	0.0369	0.5070	1.1177	0.4536
	105.0	41.4	56.8	56.8	1.6	58.4	0.192	0.009	0.183	13.3193	13.2513	0.0680	0.3711	1.1175	0.3321
	101.6	11.2	58.2	58.2	0.5	58.7	0.213	0.008	0.205	13.2513	13.2127	0.0386	0.4157	1.1174	0.3720
	95.9	6.3	58.4	58.4	0.4	58.6	0.165	0.010	0.155	13.2127	13.1742	0.0385	0.3143	1.1173	0.2813

NOTES:  
 TC2 - Thermocouple located after the tuft slightly above the rotor.  
 TC3 - Thermocouple located before the tuft slightly above the rotor  
 DL - Drag Load (lbs @ 6.085 in. radius)

SiC - Silicon Carbide Fibers

20 - 20,000 RPM's  
 30 - 30,000 RPM's  
 40 - 40,000 RPM's

CLD - Cold Air (7.5 scfm)

S - Small Weight 164.30g  
 M - Medium Weight 259.73g  
 L - Large Weight 493.56g

CF - Coefficient of Friction

# SiC on BN/PSZ

Cold Air(7.5 scfm) / Small Wt.

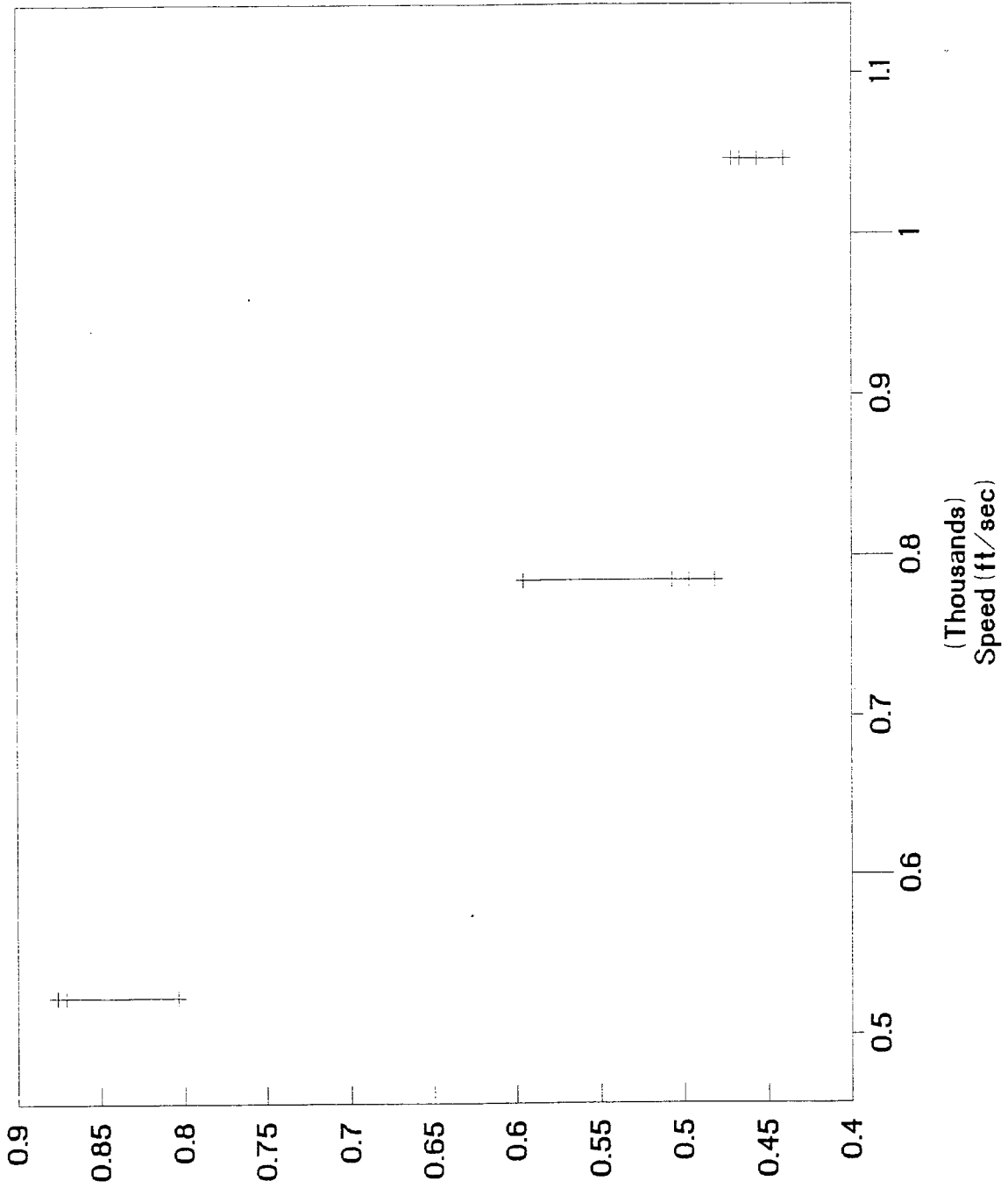

# SiC on BN/PSZ

Cold Air (7.5 scfm) / Medium Wt.

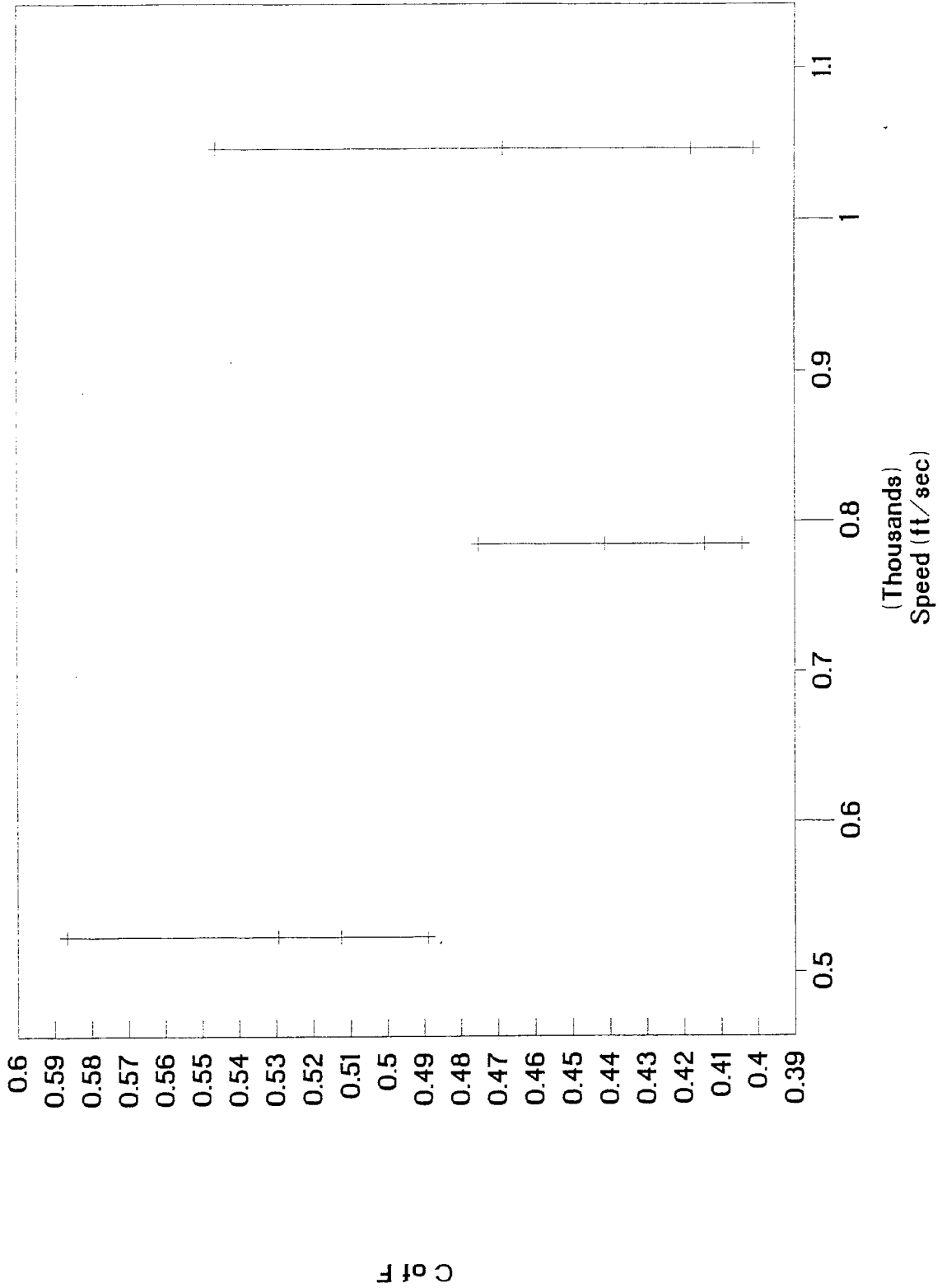

# SiC on BN/PSZ

Cold Air (7.5 scfm) / Large Wt.

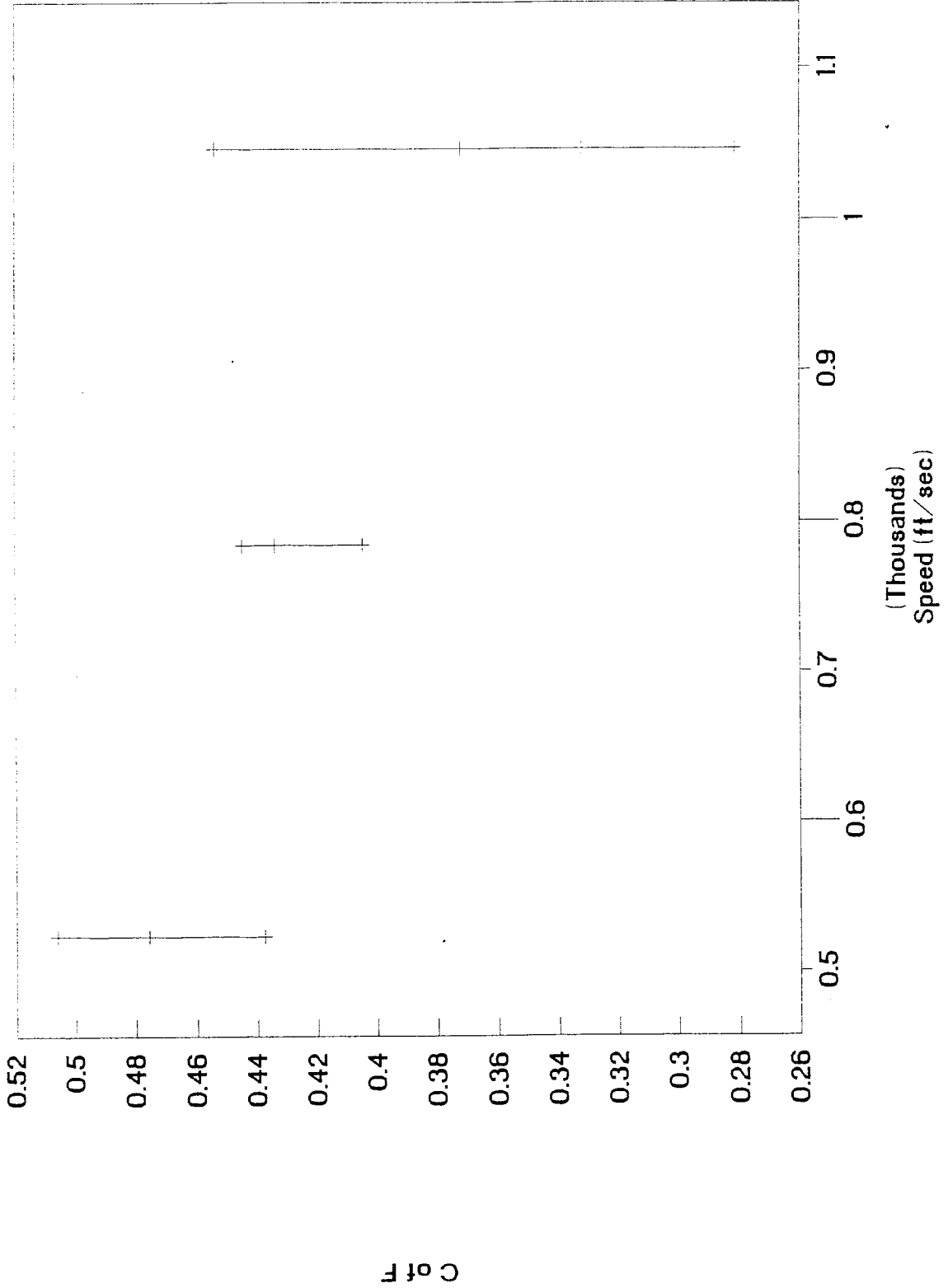

# TUFT TESTING RESULTS

PART #8 TRAC A PN 036 20000 RPMs  
 PART #8 TRAC B PN 037 30000 RPMs  
 PART #8 TRAC C PN 037 40000 RPMs

PSZ COATED ROTOR  
 AMBIENT AIR TESTING

FIBER/ TEST	END TC2(F)	START TC2(F)	TEMP CHANGE(F)	END TC3(F)	START TC3(F)	TEMP CHANGE(F)	END DL	START DL	CHANGE DL	START IFT WT(g)	END IFT WT(g)	LOSS(g)	WT LOSS(g)	DRAG (lb)	N (lb)	Cf
SiC/S20/AMB	90.2	64.1	26.1	81.2	66.1	15.1	0.130	0.007	0.123	13.3586	13.3510	0.0076	0.0076	0.2494	0.3917	0.6368
	90.5	68.0	22.5	80.0	65.0	14.0	0.123	0.001	0.122	13.3510	13.3480	0.0030	0.0030	0.2474	0.3917	0.6316
	90.5	76.7	13.8	79.7	68.2	11.5	0.126	0.003	0.123	13.3480	13.3456	0.0024	0.0024	0.2494	0.3917	0.6368
	91.0	73.1	17.9	80.2	68.0	12.2	0.123	0.005	0.118	13.3456	13.3436	0.0020	0.0020	0.2393	0.3917	0.6109
SiC/M20/AMB	104.5	63.8	40.7	92.9	68.8	24.1	0.185	0.007	0.178	13.3436	13.3420	0.0016	0.0016	0.3610	0.6021	0.5995
	105.3	79.1	26.2	92.3	72.2	20.1	0.179	0.005	0.174	13.3420	13.3384	0.0036	0.0036	0.3529	0.6021	0.5861
	105.6	82.0	23.6	92.0	73.7	18.3	0.163	0.006	0.157	13.3384	13.3345	0.0039	0.0039	0.3184	0.6021	0.5288
	104.6	83.2	21.4	90.9	74.2	16.7	0.165	0.004	0.161	13.3345	13.3321	0.0024	0.0024	0.3265	0.6021	0.5423
SiC/L20/AMB	133.5	70.9	62.6	116.6	71.2	45.4	0.323	0.006	0.317	13.3321	13.2630	0.0691	0.0691	0.6429	1.1175	0.5753
	129.1	94.2	34.9	116.1	75.9	40.2	0.281	0.006	0.275	13.2630	13.2312	0.0318	0.0318	0.5577	1.1175	0.4991
	116.1	94.0	22.1	103.0	77.3	25.7	0.245	0.001	0.244	13.2312	13.2012	0.0300	0.0300	0.4948	1.1174	0.4428
	116.0	93.0	23.0	104.7	78.3	26.4	0.265	0.007	0.258	13.2012	13.1780	0.0232	0.0232	0.5292	1.1174	0.4683
SiC/S30/AMB	119.2	89.9	29.3	108.0	95.8	12.2	0.046	0.007	0.039	13.0622	13.0606	0.0016	0.0016	0.0791	0.3911	0.4823
	125.7	101.2	24.5	113.5	94.2	19.3	0.098	0.005	0.093	13.0606	13.0590	0.0016	0.0016	0.1886	0.3911	0.4823
	132.2	102.3	29.9	116.0	94.7	21.3	0.140	0.003	0.137	13.0590	13.0584	0.0006	0.0006	0.2778	0.3911	0.7104
	145.3	81.3	64.0	121.3	94.9	26.4	0.185	0.008	0.177	13.0584	13.0515	0.0069	0.0069	0.3590	0.3911	0.9179
SiC/M30/AMB	145.2	102.6	42.6	123.8	96.5	27.3	0.040	0.007	0.033	13.0515	13.0438	0.0077	0.0077	0.0669	0.6015	0.1113
	139.7	113.6	26.1	119.8	98.1	21.7	0.032	0.009	0.023	13.0438	13.0399	0.0044	0.0044	0.0466	0.6014	0.0776
	128.7	110.2	18.5	111.8	98.6	13.2	0.027	0.010	0.017	13.0399	13.0047	0.0052	0.0052	0.0345	0.6014	0.0573
	122.2	109.0	13.2	108.1	98.5	9.6	0.075	0.009	0.066	13.0047	13.0000	0.0047	0.0047	0.1338	0.6014	0.2226
SiC/L30/AMB	128.8	79.4	49.4	124.3	93.3	31.0	0.206	0.009	0.197	13.0000	12.9608	0.0392	0.0392	0.3995	1.1169	0.3577
	141.0	110.0	31.0	122.8	99.2	23.6	0.081	0.008	0.073	12.9608	12.9146	0.0462	0.0462	0.1480	1.1168	0.1326
	145.0	117.9	27.1	128.5	100.1	28.4	0.094	0.009	0.085	12.9146	12.8510	0.0636	0.0636	0.1724	1.1166	0.1544
	149.1	106.0	43.1	128.3	97.5	30.8	0.225	0.009	0.216	13.2494	13.1849	0.0645	0.0645	0.4380	1.1174	0.3920
SiC/S40/AMB	135.5	106.0	29.5	122.1	109.5	12.6	0.104	0.007	0.097	13.1819	13.1760	0.0059	0.0059	0.1967	0.3913	0.5027
	135.3	116.1	19.2	118.7	110.2	8.5	0.102	0.008	0.094	13.1760	13.1755	0.0005	0.0005	0.2006	0.3913	0.4871
	136.6	116.5	20.1	117.7	110.4	7.3	0.108	0.008	0.100	13.1755	13.1720	0.0035	0.0035	0.2028	0.3913	0.5182
	136.8	116.8	20.0	120.6	109.8	10.8	0.110	0.007	0.103	13.1720	13.1680	0.0040	0.0040	0.2089	0.3913	0.5338
SiC/M40/AMB	138.3	98.4	39.9	121.4	110.3	11.1	0.113	0.008	0.105	13.1680	13.1596	0.0084	0.0084	0.2129	0.6017	0.3539
	140.5	119.4	21.1	122.1	113.0	9.1	0.137	0.008	0.129	13.1596	13.1465	0.0131	0.0131	0.2616	0.6017	0.4348
	138.2	120.2	18.0	120.9	112.2	8.7	0.146	0.007	0.139	13.1465	13.1207	0.0258	0.0258	0.2819	0.6016	0.4685
	136.6	119.4	17.2	119.6	111.1	8.5	0.148	0.006	0.142	13.1207	13.0946	0.0261	0.0261	0.2880	0.6016	0.4787
SiC/L40/AMB	DISC	DISC	DISC	DISC	DISC	DISC	DISC	DISC	DISC	DISC	DISC	DISC	DISC	DISC	DISC	DISC
	DISC	DISC	DISC	DISC	DISC	DISC	DISC	DISC	DISC	DISC	DISC	DISC	DISC	DISC	DISC	DISC
	DISC	DISC	DISC	DISC	DISC	DISC	DISC	DISC	DISC	DISC	DISC	DISC	DISC	DISC	DISC	DISC
	DISC	DISC	DISC	DISC	DISC	DISC	DISC	DISC	DISC	DISC	DISC	DISC	DISC	DISC	DISC	DISC

NOTES:  
 TC2 - Thermocouple located after the tuft slightly above the rotor.  
 TC3 - Thermocouple located before the tuft slightly above the rotor  
 DL - Drag Load (lbs @ 6.085 in. radius)

SiC - Silicon Carbide Fibers

20 - 20,000 RPM's  
 30 - 30,000 RPM's  
 40 - 40,000 RPM's

AMB - Ambient Air (no flow)

S - Small Weight 164.30g  
 M - Medium Weight 259.73g  
 L - Large Weight 493.56g

CF - Coefficient of Friction

# SiC on PSZ

Ambient Air / Small Wt.

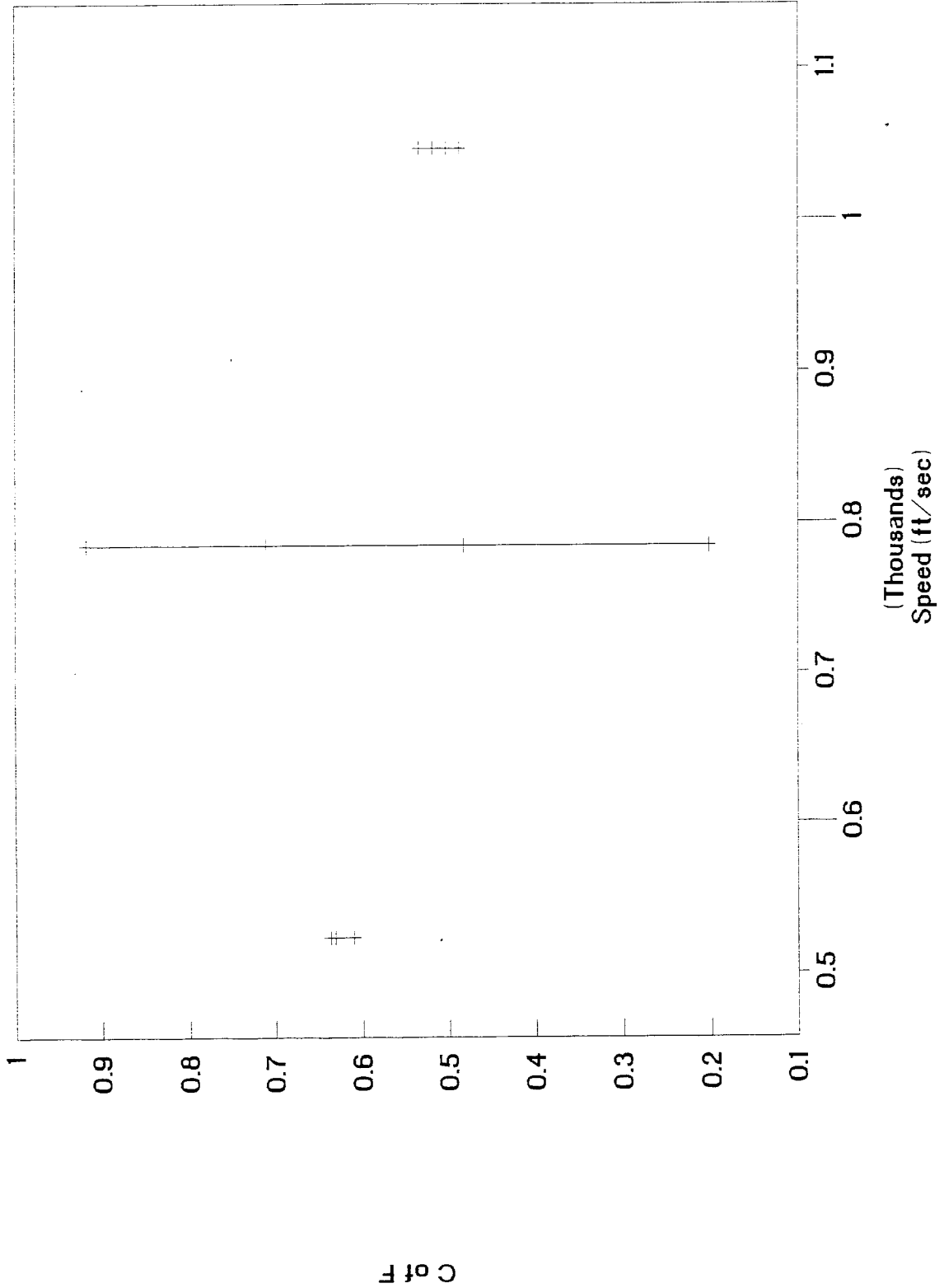

# SiC on PSZ

Ambient Air / Medium Wt.

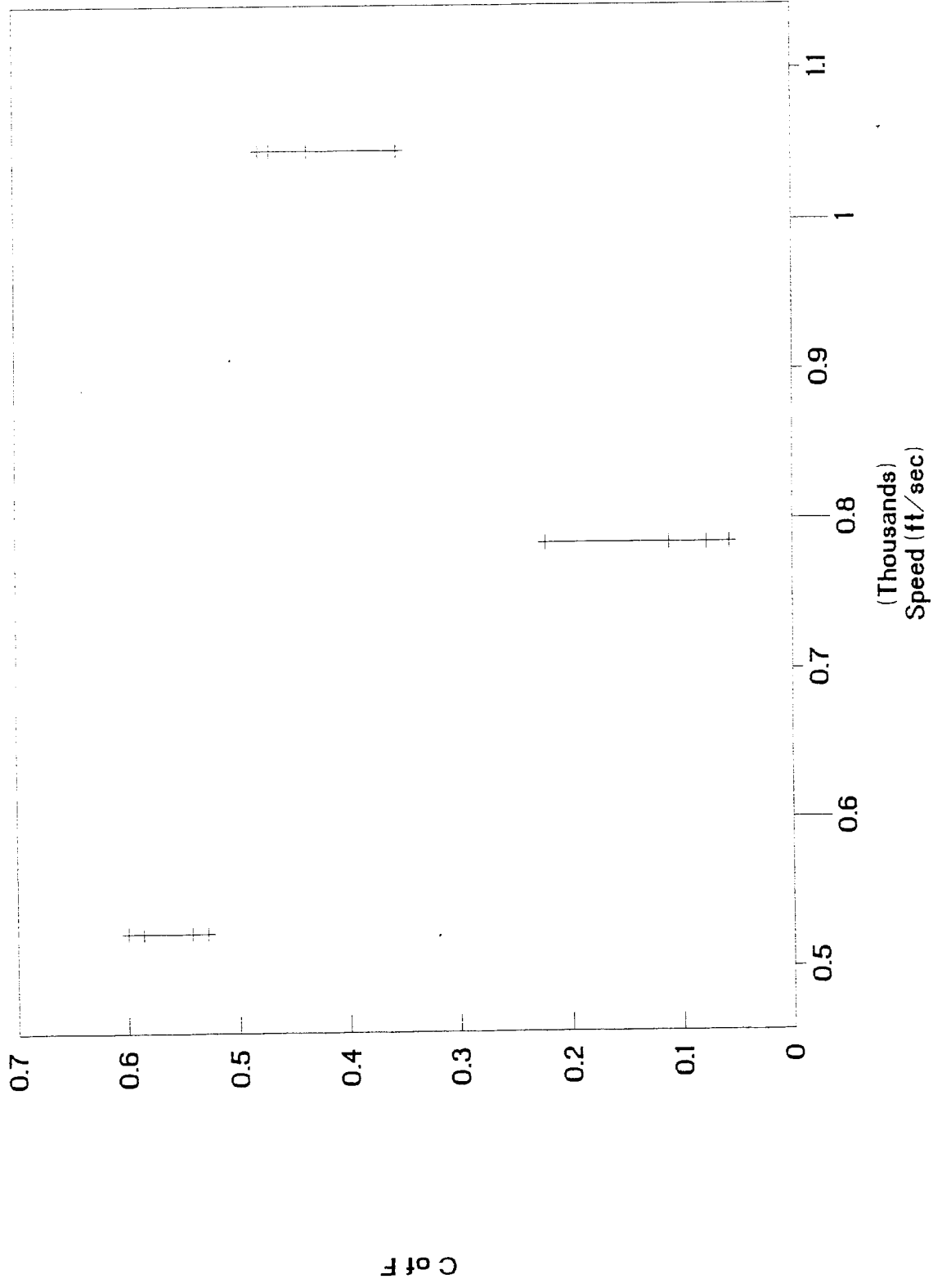

# SiC on PSZ

Ambient Air / Large Wt.

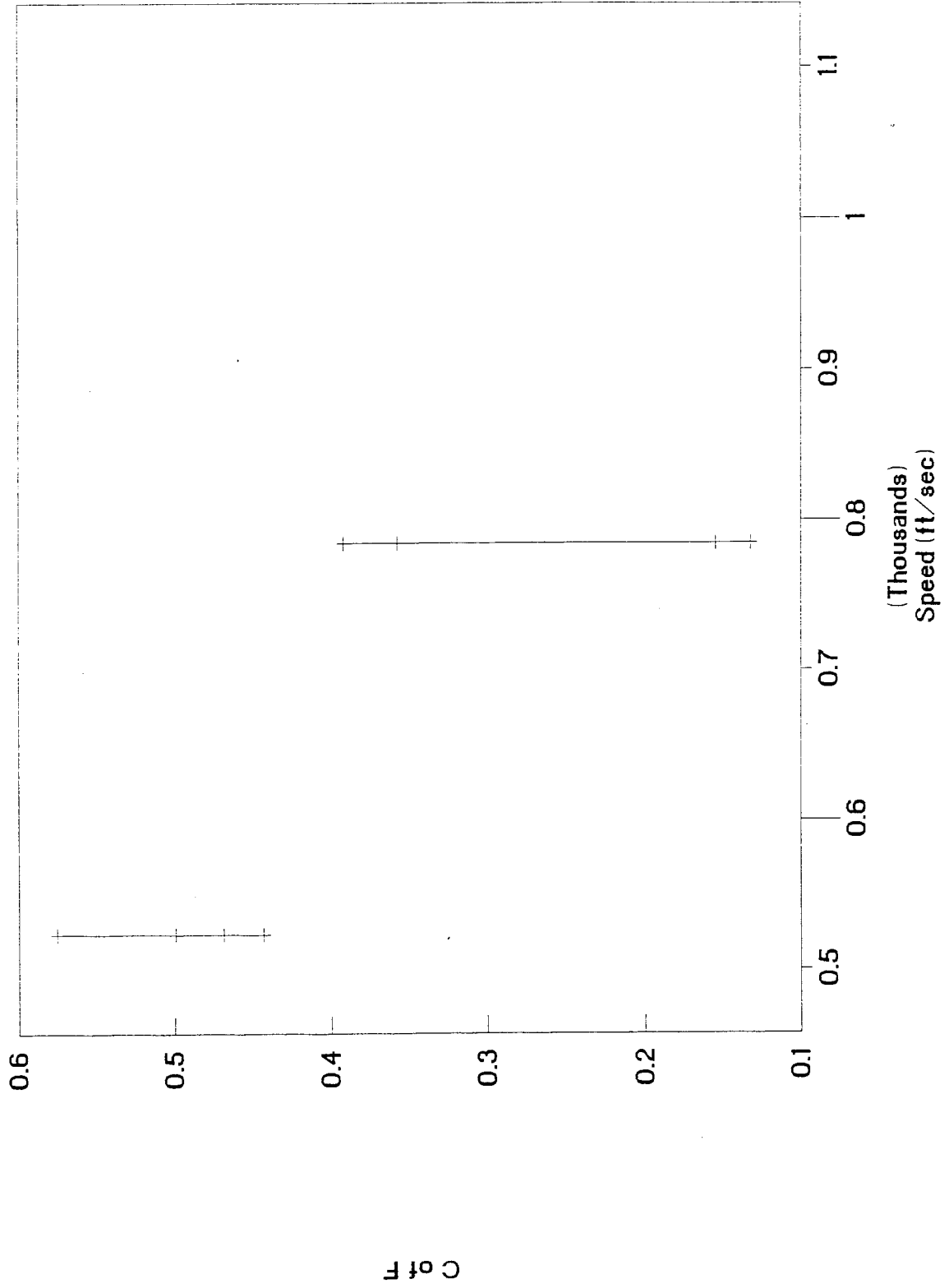

# TUFT TESTING RESULTS

CHROME CARBIDE COATED ROTOR  
AMBIENT AIR TESTING

PART #7 TRACK A

PN 019; SIC/S20 THRU SIC/L30  
PN 020 REMAINDER

FIBER/ TEST	END IC2(F)	START IC2(F)	TEMP CHANGE(°F)	END IC3(°F)	START IC3(°F)	TEMP CHANGE(°C)	END DL	START DL	DL CHANGE	START JETLW(G)	END JETLW(G)	END LOSS(G)	WT DRAG	N (lb)	CI
SIC/S20/AMB	90.5	71.5	19.0	90.1	79.3	10.8	0.076	0.004	0.072	13.1418	13.1400	0.0018	0.1460	0.3913	0.3732
	88.8	80.0	8.8	87.1	80.0	7.1	0.058	0.003	0.055	13.1400	13.1395	0.0005	0.1115	0.3913	0.2851
	82.6	70.4	12.2	82.7	76.0	6.7	0.065	0.005	0.050	13.1342	13.1336	0.0006	0.1014	0.3912	0.2592
	81.5	74.9	6.7	81.0	76.2	4.8	0.052	0.006	0.046	13.1336	13.1336	0.0000	0.0933	0.3912	0.2384
SIC/M20/AMB	130.8	75.2	55.6	124.9	74.7	50.2	0.340	0.004	0.336	13.1336	13.1321	0.0015	0.6814	0.6017	1.1325
	106.6	91.0	15.6	101.8	78.4	23.4	0.225	0.006	0.219	13.1321	13.1316	0.0005	0.4441	0.6017	0.7382
	107.4	82.1	25.3	103.1	75.0	28.1	0.232	0.003	0.232	13.1316	13.1314	0.0002	0.4705	0.6017	0.7820
	116.4	78.0	38.4	110.4	74.0	36.4	0.293	0.004	0.289	13.1314	13.1302	0.0012	0.5861	0.6017	0.9741
SIC/L20/AMB	136.0	81.8	53.2	115.1	74.9	40.2	0.253	0.004	0.249	13.1302	13.1172	0.0130	0.5050	1.1172	0.4520
	126.6	85.0	41.6	111.7	76.0	35.7	0.251	0.004	0.247	13.1172	13.1134	0.0038	0.5009	1.1172	0.4484
	131.0	71.0	60.0	120.9	77.8	43.1	0.307	0.006	0.301	13.1134	13.1054	0.0080	0.6104	1.1172	0.5464
	129.9	88.3	41.6	118.3	79.3	39.0	0.327	0.007	0.320	13.1054	13.0998	0.0056	0.6490	1.1172	0.5809
SIC/S30/AMB	117.8	94.2	23.6	108.3	96.5	11.8	0.085	0.007	0.078	13.0998	13.0946	0.0052	0.1582	0.3912	0.4044
	117.4	103.5	13.9	108.9	99.0	9.9	0.092	0.007	0.085	13.0946	13.0910	0.0036	0.1724	0.3911	0.4407
	112.8	103.4	9.4	106.0	99.1	6.9	0.071	0.008	0.063	13.0904	13.0864	0.0040	0.1278	0.3911	0.3266
	113.3	99.0	14.3	106.9	98.7	8.2	0.070	0.005	0.065	13.0864	13.0828	0.0036	0.1318	0.3911	0.3370
SIC/M30/AMB	118.5	84.0	34.5	110.9	93.5	17.4	0.095	0.005	0.090	13.0828	13.0752	0.0076	0.1825	0.6015	0.3034
	121.0	99.0	22.0	111.8	99.0	12.8	0.094	0.005	0.089	13.0752	13.0668	0.0084	0.1805	0.6015	0.3001
	119.3	103.7	15.6	110.9	100.3	10.6	0.089	0.005	0.084	13.0668	13.0570	0.0098	0.1704	0.6015	0.2832
	117.8	103.7	14.1	109.5	100.4	9.1	0.078	0.005	0.073	13.0570	13.0470	0.0100	0.1480	0.6015	0.2461
SIC/L30/AMB	133.2	99.5	33.7	124.7	99.4	25.3	0.171	0.003	0.168	13.0470	13.0205	0.0265	0.3407	1.1170	0.3050
	133.6	91.1	41.7	124.6	98.8	25.8	0.168	0.005	0.163	13.0205	13.0080	0.0325	0.3306	1.1169	0.2960
	162.7	103.2	59.5	140.8	100.9	39.9	0.123	0.005	0.118	12.9404	12.9007	0.0397	0.2383	1.1167	0.2143
	160.4	125.2	35.2	130.6	109.0	22.6	0.206	0.004	0.202	12.9007	12.8760	0.0247	0.4097	1.1167	0.3688
SIC/S40/AMB	138.2	117.6	20.6	129.2	126.2	3.0	0.064	0.003	0.061	12.8758	12.8642	0.0116	0.1237	0.3906	0.3167
	136.7	123.1	13.6	130.0	122.8	7.2	0.061	0.002	0.059	12.8642	12.8568	0.0074	0.1197	0.3906	0.3063
	138.4	124.0	14.4	131.0	124.5	6.5	0.058	0.003	0.055	12.8568	12.8484	0.0084	0.1115	0.3906	0.2856
	135.1	124.7	10.4	127.3	125.4	1.9	0.060	0.003	0.057	12.8484	12.8414	0.0070	0.1156	0.3906	0.2959
SIC/M40/AMB	141.3	123.6	17.7	132.2	124.1	8.1	0.090	0.004	0.086	12.8414	12.8277	0.0137	0.1744	0.6010	0.2902
	140.6	125.5	15.1	132.0	124.4	7.6	0.086	0.004	0.082	12.8277	12.8166	0.0111	0.1663	0.6010	0.2767
	139.5	127.3	12.2	131.0	127.2	3.8	0.087	0.003	0.084	12.8166	12.8045	0.0121	0.1704	0.6009	0.2635
	144.3	117.9	26.4	137.8	128.3	9.5	0.084	0.004	0.080	12.8045	12.7915	0.0130	0.1622	0.6009	0.2700
SIC/L40/AMB	158.6	131.1	27.5	148.0	131.0	17.0	0.161	0.002	0.159	12.7915	12.7589	0.0346	0.3225	1.1164	0.2888
	155.7	134.0	21.7	145.5	137.5	8.0	0.186	0.003	0.183	12.7589	12.7232	0.0337	0.3711	1.1164	0.3324
	158.4	133.9	24.5	146.7	131.0	15.7	0.182	0.003	0.179	12.7232	12.6879	0.0353	0.3630	1.1163	0.3252
	157.3	134.7	22.8	144.5	130.2	14.3	0.183	0.003	0.180	12.6879	12.6510	0.0369	0.3650	1.1162	0.3279

NOTES:

- TC2 - Thermocouple located after the tuft slightly above the rotor.
- TC3 - Thermocouple located before the tuft slightly above the rotor
- DL - Drag Load (lbs @ 6.085 in.radius)

SIC - Silicon Carbide Fibers

- 20 - 20,000 RPM's
- 30 - 30,000 RPM's
- 40 - 40,000 RPM's

AMB - Ambient Air (no flow)

- S - Small Weight 164.30g
- M - Medium Weight 259.73g
- L - Large Weight 493.56

CF - Coefficient of Friction

\*\*\* - Test Failure

# SiC on Chrome Carbide

Ambient Air / Small Wt.

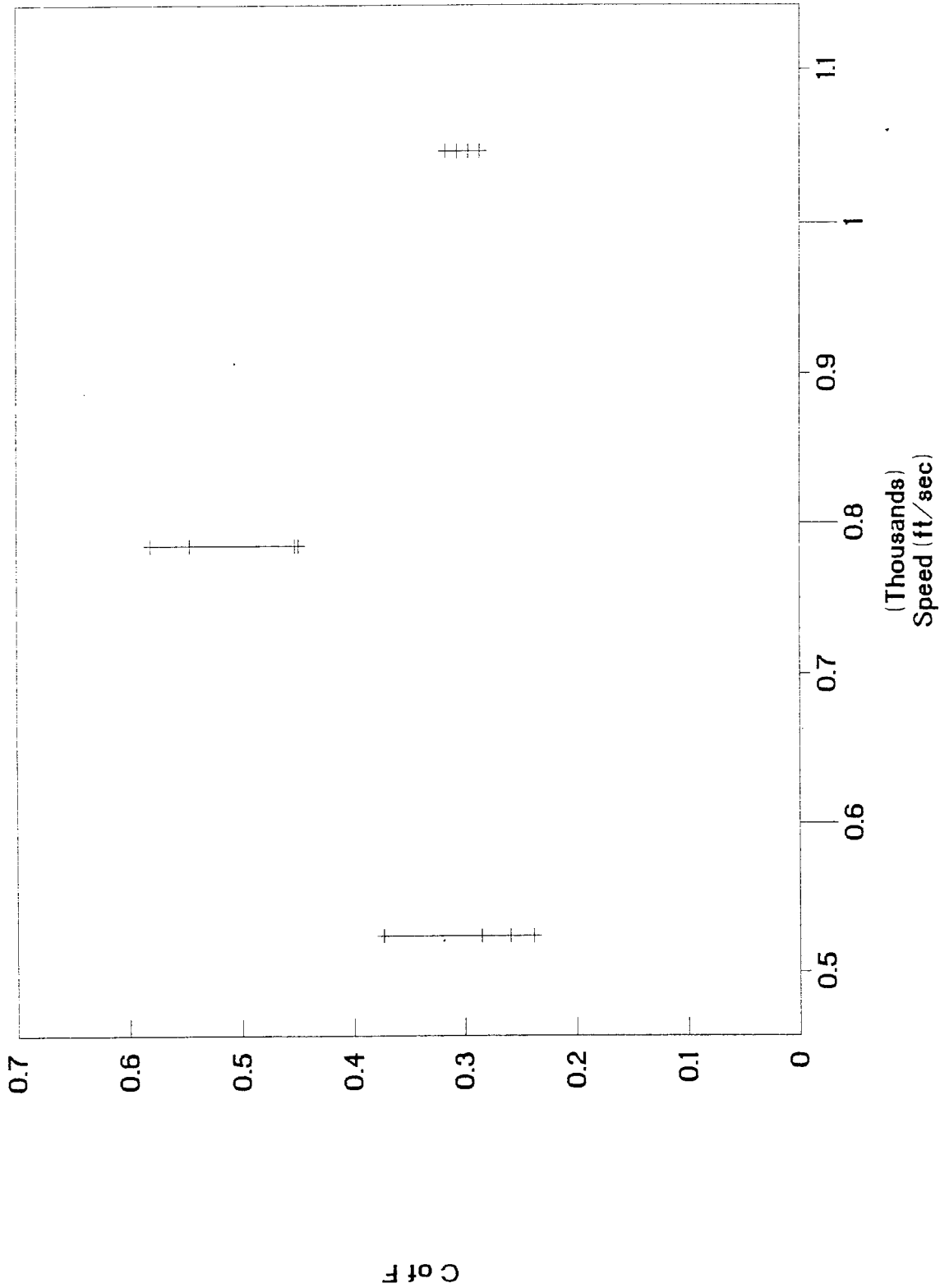

# SiC on Chrome Carbide

Ambient Air / Medium Wt.

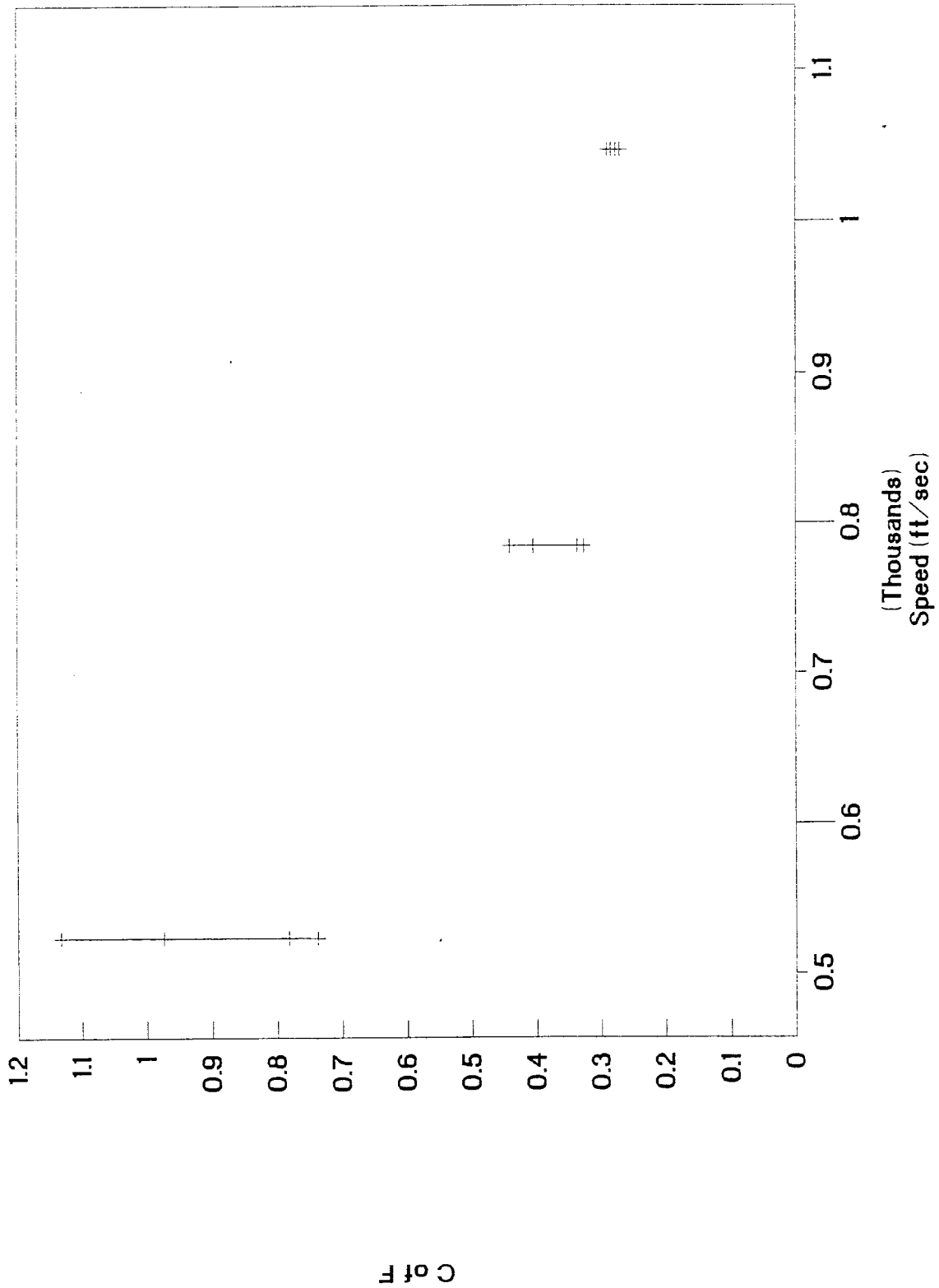

# SiC on Chrome Carbide

Ambient Air / Large Wt.

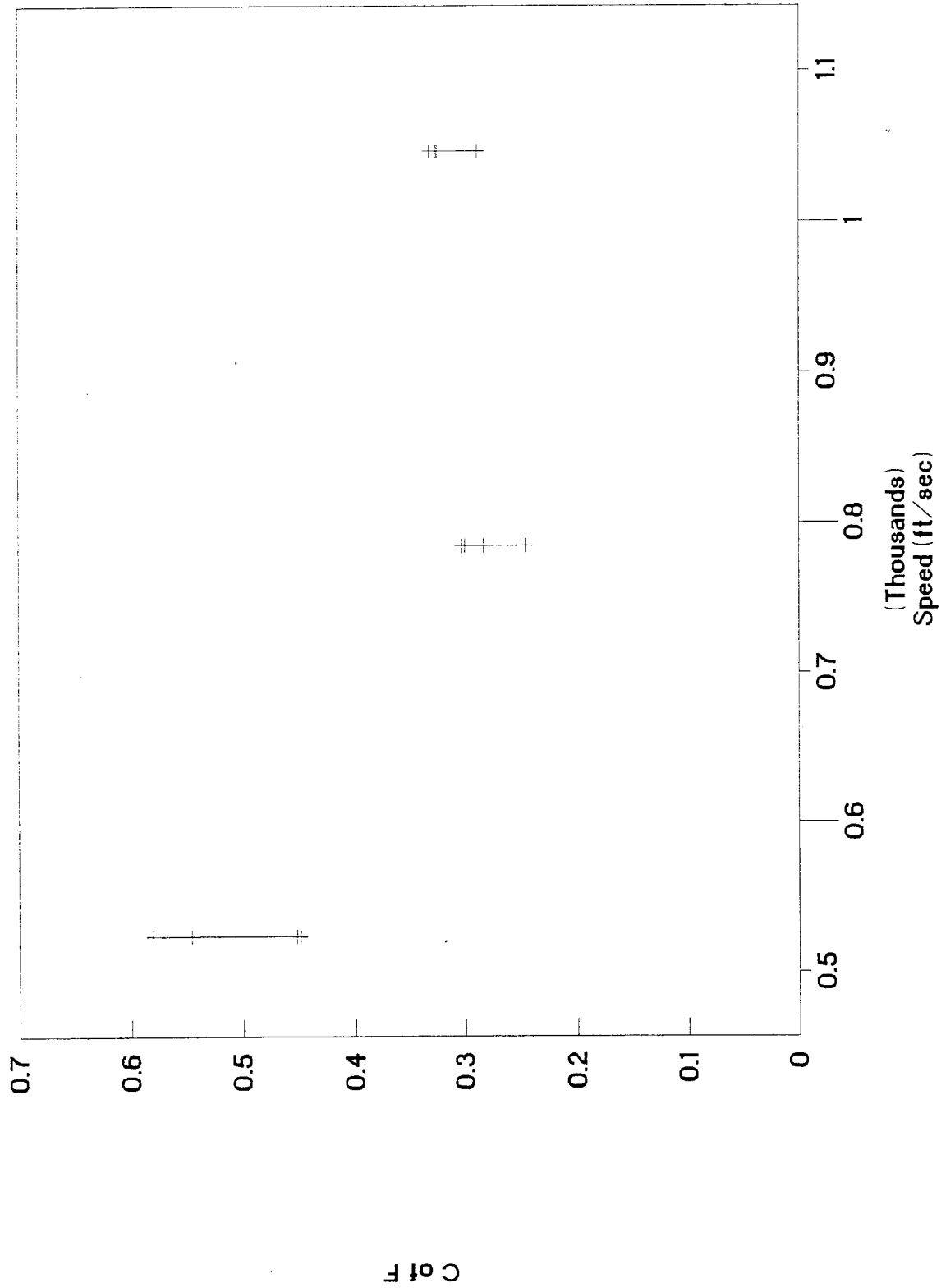

# TUFT TESTING RESULTS

CHROME CARBIDE COATED ROTOR  
COLD AIR TESTING

PART #7 TRACK B  
PN 026 SIC/S20 - SIC/S40(1)  
PN 036 LAST THREE

FIBER/TEST	END IC2(°F)	START IC2(°F)	TEMP CHANGE(°F)	END IC3(°F)	START IC3(°F)	TEMP CHANGE(°F)	END DL	START DL	DL CHANGE	DL IFTW(I(g))	START IFTW(I(g))	END IFTW(I(g))	LOSS(g)	WT DRAG (lb)	N (lb)	CI
SIC/S20/CLD	81.3	74.2	7.1	73.1	73.0	0.1	0.055	0.004	0.051	12.9158	12.9137	12.9137	0.0021	0.1034	0.3908	0.2647
	82.7	77.3	5.4	73.2	73.1	0.1	0.072	0.005	0.067	12.9137	12.9127	12.9127	0.0010	0.1359	0.3908	0.3477
	83.2	75.1	8.1	74.2	73.8	0.4	0.071	0.006	0.065	12.9127	12.9127	12.9127	0.0000	0.1318	0.3908	0.3379
	82.9	78.8	4.1	74.0	74.0	0.0	0.057	0.004	0.053	12.9127	12.9120	12.9120	0.0007	0.1075	0.3908	0.2751
SIC/M20/CLD	84.9	78.8	6.1	73.9	73.9	0.0	0.069	0.004	0.065	12.9120	12.9111	12.9111	0.0009	0.1724	0.6012	0.2867
	88.7	80.0	8.7	73.9	73.8	0.1	0.070	0.006	0.064	12.9111	12.9107	12.9107	0.0004	0.1286	0.6012	0.2159
	86.9	75.8	11.0	74.6	74.2	0.4	0.098	0.006	0.092	12.9107	12.9096	12.9096	0.0011	0.1866	0.6012	0.3104
	86.7	81.0	5.7	74.5	74.5	0.0	0.094	0.006	0.088	12.9096	12.9091	12.9091	0.0005	0.1786	0.6012	0.2969
SIC/L20/CLD	83.9	61.7	22.2	61.4	60.7	0.7	0.237	0.007	0.230	12.6525	12.6415	12.6415	0.0110	0.4664	1.1162	0.4179
	83.9	73.0	10.9	61.6	61.2	0.4	0.230	0.007	0.223	12.6415	12.6331	12.6331	0.0084	0.4522	1.1162	0.4052
	86.6	75.0	11.6	61.7	61.3	0.4	0.242	0.007	0.235	12.6331	12.6203	12.6203	0.0128	0.4766	1.1161	0.4270
	86.8	76.3	10.5	62.0	61.8	0.2	0.239	0.009	0.230	12.6203	12.6058	12.6058	0.0145	0.4664	1.1161	0.4179
SIC/S30/CLD	86.8	74.0	12.8	60.1	60.9	-0.8	0.069	0.007	0.062	12.8907	12.8883	12.8883	0.0024	0.1663	0.3907	0.4256
	95.6	76.2	19.4	60.0	60.2	-0.2	0.135	0.006	0.129	12.8883	12.8883	12.8883	0.0000	0.2616	0.3907	0.6696
	86.4	80.2	6.2	59.5	60.1	-0.6	0.127	0.006	0.121	12.8883	12.8874	12.8874	0.0009	0.2454	0.3907	0.6281
	82.9	76.3	6.6	59.5	60.5	-1.0	0.076	0.006	0.070	12.8874	12.8867	12.8867	0.0007	0.1420	0.3907	0.3634
SIC/M30/CLD	96.5	73.7	22.8	60.3	59.5	0.8	0.130	0.007	0.123	12.8867	12.8773	12.8773	0.0094	0.2494	0.6011	0.4150
	110.0	85.4	24.6	60.9	60.3	0.6	0.171	0.007	0.164	12.8773	12.8717	12.8717	0.0056	0.3326	0.6011	0.5633
	112.2	85.1	27.1	60.6	60.2	0.4	0.169	0.006	0.163	12.8717	12.8704	12.8704	0.0013	0.3306	0.6011	0.5499
	110.5	87.6	22.9	60.5	60.0	0.5	0.184	0.007	0.177	12.8704	12.8657	12.8657	0.0047	0.3690	0.6011	0.5972
SIC/L30/CLD	114.1	74.2	39.9	60.5	58.9	1.6	0.225	0.007	0.218	12.8657	12.8507	12.8507	0.0350	0.4421	1.1166	0.3959
	121.5	91.3	30.2	60.7	60.0	0.7	0.228	0.007	0.221	12.8507	12.8482	12.8482	0.0246	0.4482	1.1165	0.4014
	121.0	87.6	33.4	60.8	60.4	0.4	0.258	0.007	0.251	12.8482	12.7756	12.7756	0.0306	0.5090	1.1165	0.4559
	114.0	91.3	22.7	60.4	59.7	0.7	0.257	0.007	0.250	12.7756	12.7464	12.7464	0.0292	0.5070	1.1164	0.4541
SIC/S40/CLD	104.2	76.9	27.3	65.3	63.6	1.7	0.078	0.006	0.072	12.7464	12.7340	12.7340	0.0124	0.1460	0.3904	0.3741
	105.2	92.2	13.0	65.8	65.3	0.5	0.080	0.006	0.074	12.7340	12.7258	12.7258	0.0082	0.1501	0.3903	0.3845
	105.2	94.0	11.2	65.6	66.2	-0.6	0.080	0.008	0.072	12.7258	12.7164	12.7164	0.0094	0.1460	0.3903	0.3741
	105.7	93.6	12.1	65.9	65.9	0.0	0.076	0.008	0.068	12.7164	12.7074	12.7074	0.0090	0.1379	0.3903	0.3632
SIC/M40/CLD	108.1	94.0	14.1	65.4	65.6	-0.2	0.121	0.008	0.113	12.7074	12.6946	12.6946	0.0128	0.2292	0.6007	0.3815
	108.6	94.1	14.5	66.1	65.9	0.2	0.118	0.007	0.111	12.6946	12.6820	12.6820	0.0126	0.2251	0.6007	0.3748
	108.2	95.4	12.8	65.9	66.5	-0.6	0.123	0.007	0.116	12.6820	12.6684	12.6684	0.0136	0.2352	0.6006	0.3917
	110.1	95.4	14.7	66.3	66.4	-0.1	0.120	0.007	0.113	12.6684	12.6525	12.6525	0.0159	0.2292	0.6006	0.3816
SIC/L40/CLD	123.2	78.6	44.6	70.2	68.9	1.3	0.190	0.008	0.182	12.6058	12.5606	12.5606	0.0452	0.3691	1.1160	0.3307
	127.5	95.8	31.7	70.8	70.0	0.8	0.172	0.008	0.164	12.5606	12.5258	12.5258	0.0326	0.3326	1.1163	0.2980
	121.8	102.2	19.6	70.8	70.7	0.1	0.163	0.009	0.154	12.5258	12.5258	12.5258	0.0509	0.3129	1.1161	0.2798
	125.8	106.1	19.7	71.4	71.8	-0.4	0.146	0.010	0.136	12.5258	12.5407	12.5407	0.0651	0.2758	1.1160	0.2472

NOTES:  
 TC2 - Thermocouple located after the tuft slightly above the rotor.  
 TC3 - Thermocouple located before the tuft slightly above the rotor  
 DL - Drag Load (lbs @ 6.086 in.radius)

SIC -- Silicon Carbide Fibers  
 20 - 20,000 RPM's  
 30 - 30,000 RPM's  
 40 - 40,000 RPM's

CLD -- COLD AIR (7.5 SCFM)  
 S - Small Weight 164.30g  
 M - Medium Weight 259.73g  
 L - Large Weight 493.56g  
 CF -- Coefficient of Friction

# SiC on Chrome Carbide

Cold Air(7.5 scfm) / Small Wt.

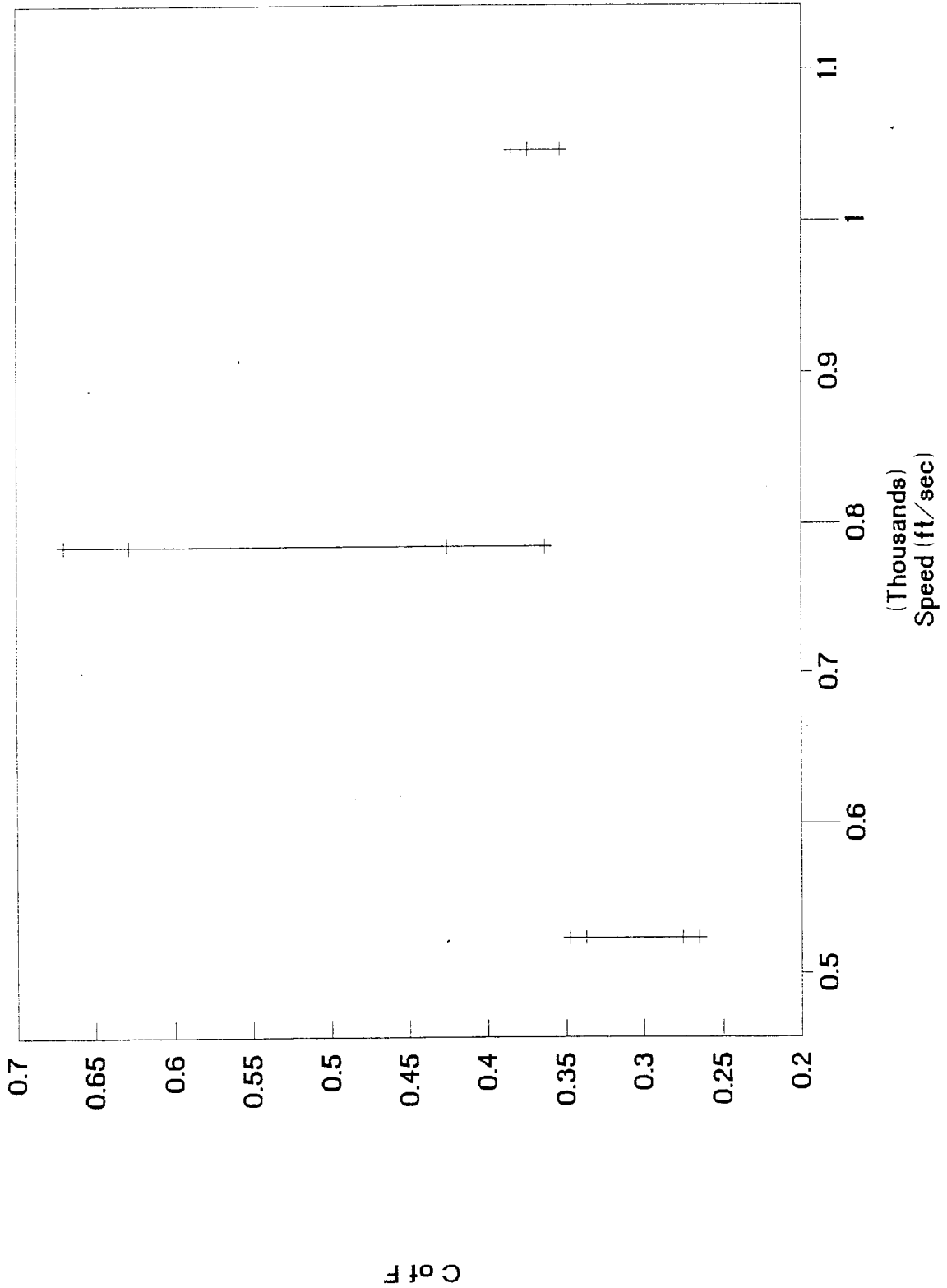

# SiC on Chrome Carbide

Cold Air(7.5 scfm) / Medium Wt.

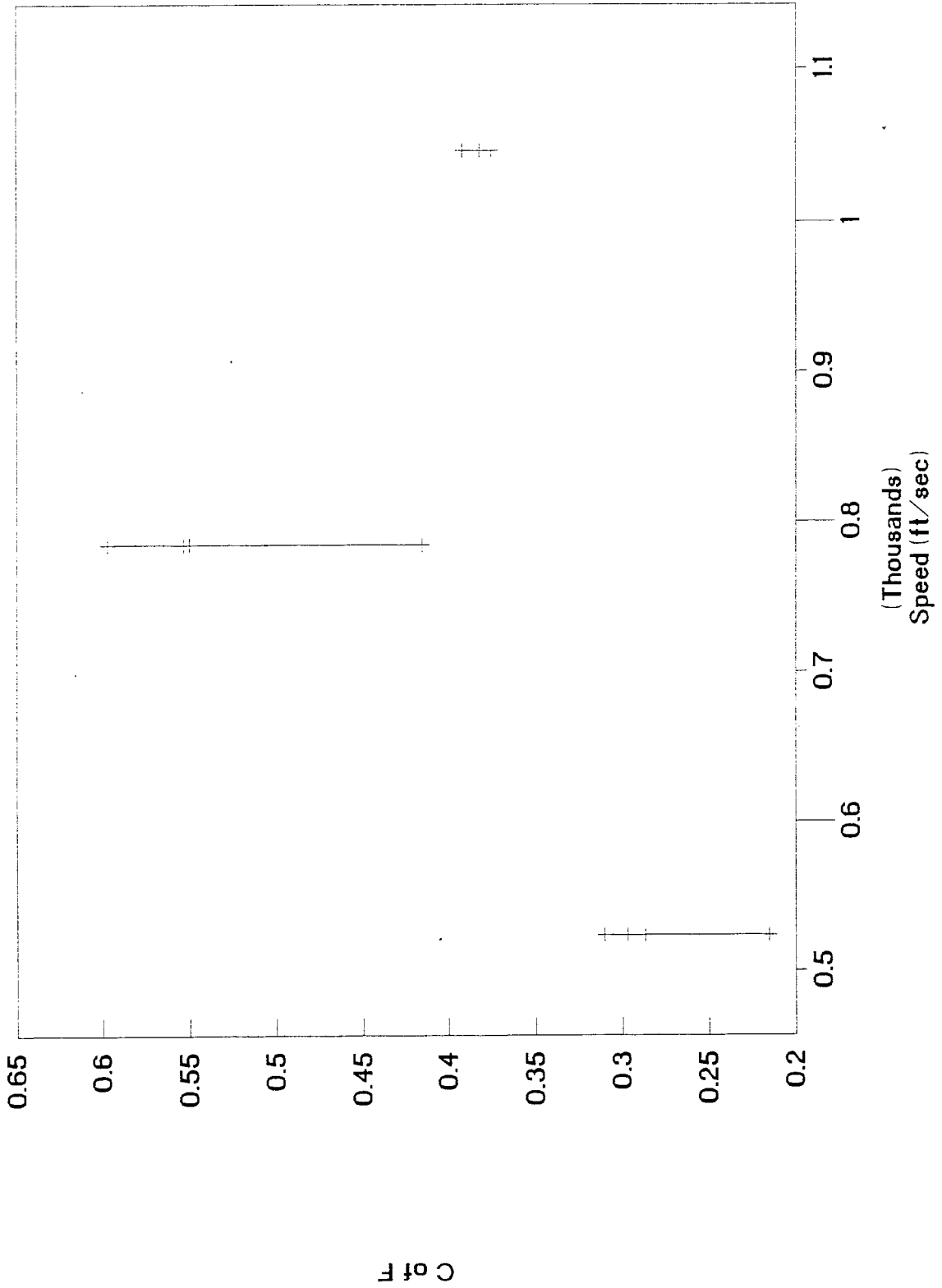

# SiC on Chrome Carbide

Cold Air(7.5 scfm) / Large Wt.

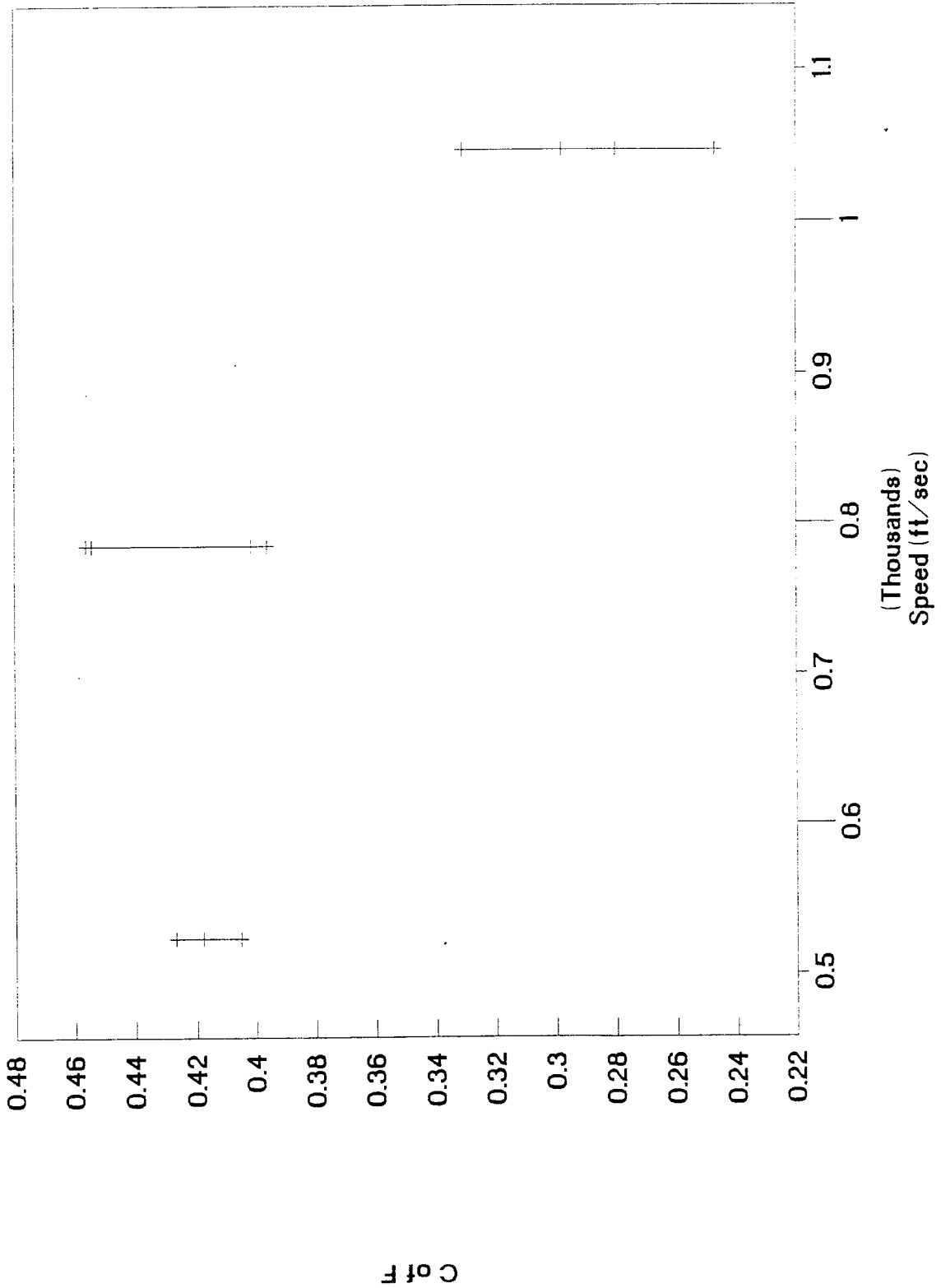

# TUFT TESTING RESULTS

BARE ROTOR  
 AMBIANT AIR TESTING

PART # 10A  
 TUFT # 050-START THRU M40(1)  
 TUFT # 051-REMAINDER

FIBER/ TEST	END TC2(°F)	START TC2(°F)	TEMP CHANGE(°F)	END TC3(°F)	START TC3(°F)	TEMP CHANGE(°F)	END DL	START DL	DL CHANGE	START IFT WT(g)	END IFT WT(g)	LOSS(g)	WT (lb)	DRAG (lb)	N (lb)	CF
SiC/S20/AMB	89.2	78.2	11.0	98.6	89.2	9.4	0.057	0.001	0.056	13.5370	13.5368	0.0002	0.1136	0.1136	0.3921	0.2896
	91.6	87.2	4.4	99.2	92.3	6.9	0.058	0.002	0.056	13.5268	13.5265	0.0003	0.1136	0.1136	0.3921	0.2896
	90.7	89.8	0.9	98.8	90.5	8.3	0.055	0.000	0.055	13.5265	13.5250	0.0015	0.1115	0.1115	0.3921	0.2845
	92.3	88.8	3.5	100.0	92.5	7.5	0.061	0.000	0.061	13.5250	13.5243	0.0007	0.1237	0.1237	0.3921	0.3155
SiC/M20/AMB	104.0	90.4	13.6	113.6	93.3	20.3	0.146	0.001	0.145	13.5243	13.5201	0.0042	0.2941	0.2941	0.6025	0.4881
	101.4	98.2	3.2	110.7	96.1	14.6	0.125	0.003	0.122	13.5201	13.5186	0.0015	0.2474	0.2474	0.6025	0.4106
	99.0	96.1	2.9	106.7	95.0	11.7	0.098	0.006	0.092	13.5186	13.5179	0.0007	0.1866	0.1866	0.6025	0.3097
	100.9	94.9	6.0	113.4	95.4	18.0	0.137	0.002	0.135	13.5179	13.5170	0.0009	0.2009	0.2009	0.6025	0.4544
SiC/L20/AMB	110.1	88.3	21.8	128.5	93.4	35.1	0.222	0.003	0.219	13.5170	13.5165	0.0005	0.4441	0.4441	1.1181	0.3972
	115.4	103.8	11.6	131.3	99.9	31.4	0.230	0.003	0.227	13.5165	13.5142	0.0023	0.4604	0.4604	1.1181	0.4117
	110.6	107.5	3.1	125.0	101.1	23.9	0.199	0.001	0.198	13.5142	13.5142	0.0000	0.4015	0.4015	1.1181	0.3591
	110.2	104.2	6.0	125.1	100.0	25.1	0.191	0.001	0.190	13.5142	13.5134	0.0008	0.3853	0.3853	1.1181	0.3446
SiC/S30/AMB	116.2	104.6	11.6	130.2	115.8	14.4	0.084	0.001	0.083	13.5134	13.5111	0.0023	0.1683	0.1683	0.3921	0.4293
	114.2	93.4	20.8	131.9	117.4	14.5	0.073	0.001	0.072	13.5111	13.5111	0.0000	0.1460	0.1460	0.3921	0.3724
	118.5	109.8	8.7	134.8	120.6	14.2	0.087	0.003	0.084	13.5111	13.5109	0.0002	0.1704	0.1704	0.3921	0.4345
	121.2	107.0	14.2	137.1	121.3	15.8	0.093	0.001	0.092	13.5109	13.5109	0.0000	0.1866	0.1866	0.3921	0.4759
SiC/M30/AMB	130.0	116.4	13.6	146.7	122.6	24.1	0.142	0.004	0.138	13.5109	13.5093	0.0016	0.2799	0.2799	0.6025	0.4645
	127.6	120.9	6.7	142.9	123.3	19.6	0.106	0.001	0.105	13.5093	13.5086	0.0007	0.2129	0.2129	0.6025	0.3594
	129.7	122.3	7.4	144.6	123.3	21.3	0.135	0.000	0.135	13.5086	13.5031	0.0055	0.2738	0.2738	0.6025	0.4544
	128.5	117.9	10.6	141.6	122.4	19.2	0.109	0.003	0.106	13.5031	13.5012	0.0019	0.2150	0.2150	0.6025	0.3568
SiC/L30/AMB	142.8	121.4	21.4	159.6	123.1	36.5	0.222	0.002	0.220	13.5012	13.4714	0.0298	0.4462	0.4462	1.1180	0.3991
	140.5	110.3	30.2	160.8	121.8	39.0	0.229	0.002	0.227	13.4714	13.4372	0.0342	0.4604	0.4604	1.1179	0.4118
	138.5	128.6	9.9	161.7	126.0	35.7	0.224	0.006	0.218	13.4372	13.4130	0.0242	0.4421	0.4421	1.1179	0.3955
	136.2	132.6	3.6	161.6	131.5	30.1	0.231	0.002	0.229	13.4130	13.3919	0.0211	0.4644	0.4644	1.1178	0.4155
SiC/S40/AMB	121.7	97.0	24.7	146.5	133.5	13.0	0.067	0.002	0.065	13.3919	13.3864	0.0055	0.1318	0.1318	0.3918	0.3664
	124.6	116.6	8.0	147.1	136.1	11.0	0.065	0.001	0.064	13.3864	13.3788	0.0076	0.1298	0.1298	0.3918	0.3313
	128.5	118.5	10.0	149.9	135.5	14.4	0.073	0.001	0.072	13.3788	13.3677	0.0111	0.1460	0.1460	0.3918	0.3727
	130.1	121.6	8.5	150.5	138.1	12.4	0.076	0.002	0.074	13.3677	13.3579	0.0098	0.1501	0.1501	0.3917	0.3631
SiC/M40/AMB	135.5	122.2	13.3	156.6	137.7	18.9	0.102	0.001	0.101	13.3579	13.3397	0.0242	0.2048	0.2048	0.6021	0.3402
	141.1	120.9	20.2	158.9	137.4	21.5	0.115	0.002	0.113	13.3579	13.3548	0.0112	0.2292	0.2292	0.6026	0.3803
	143.0	127.7	15.3	159.7	138.8	20.9	0.122	0.002	0.120	13.3548	13.3530	0.0118	0.2434	0.2434	0.6026	0.4039
	141.5	130.5	11.0	158.8	139.9	18.9	0.118	0.001	0.117	13.3530	13.3412	0.0118	0.2373	0.2373	0.6026	0.3938
SiC/L40/AMB	151.6	87.8	63.8	178.2	134.0	44.2	0.200	0.002	0.198	13.3412	13.5102	0.0310	0.4015	0.4015	1.1181	0.3591
	149.5	125.1	24.4	173.4	139.7	33.7	0.179	0.001	0.178	13.5102	13.4805	0.0297	0.3610	0.3610	1.1180	0.3229
	145.2	101.3	43.9	174.8	140.0	34.8	0.184	0.000	0.184	13.4805	13.4444	0.0361	0.3732	0.3732	1.1179	0.3338
	148.1	131.2	16.9	175.2	144.0	31.2	0.188	0.001	0.187	13.4444	13.3964	0.0480	0.3792	0.3792	1.1178	0.3333

NOTES:  
 TC2 - Thermocouple located after the tuft slightly above the rotor.  
 TC3 - Thermocouple located before the tuft slightly above the rotor  
 DL - Drag Load (lbs @ 6.085 in. radius)

AMB -- Ambient Air (no flow)

S - Small Weight 164.30g  
 M - Medium Weight 259.73g  
 L - Large Weight 493.56

CF -- Coefficient of Friction

SiC - Silicon Carbide Fibers  
 20 - 20,000 RPM's  
 30 - 30,000 RPM's  
 40 - 40,000 RPM's

FILE: TTRPNAS1

# SiC on Bare Rotor

Ambient Air / Small Wt.

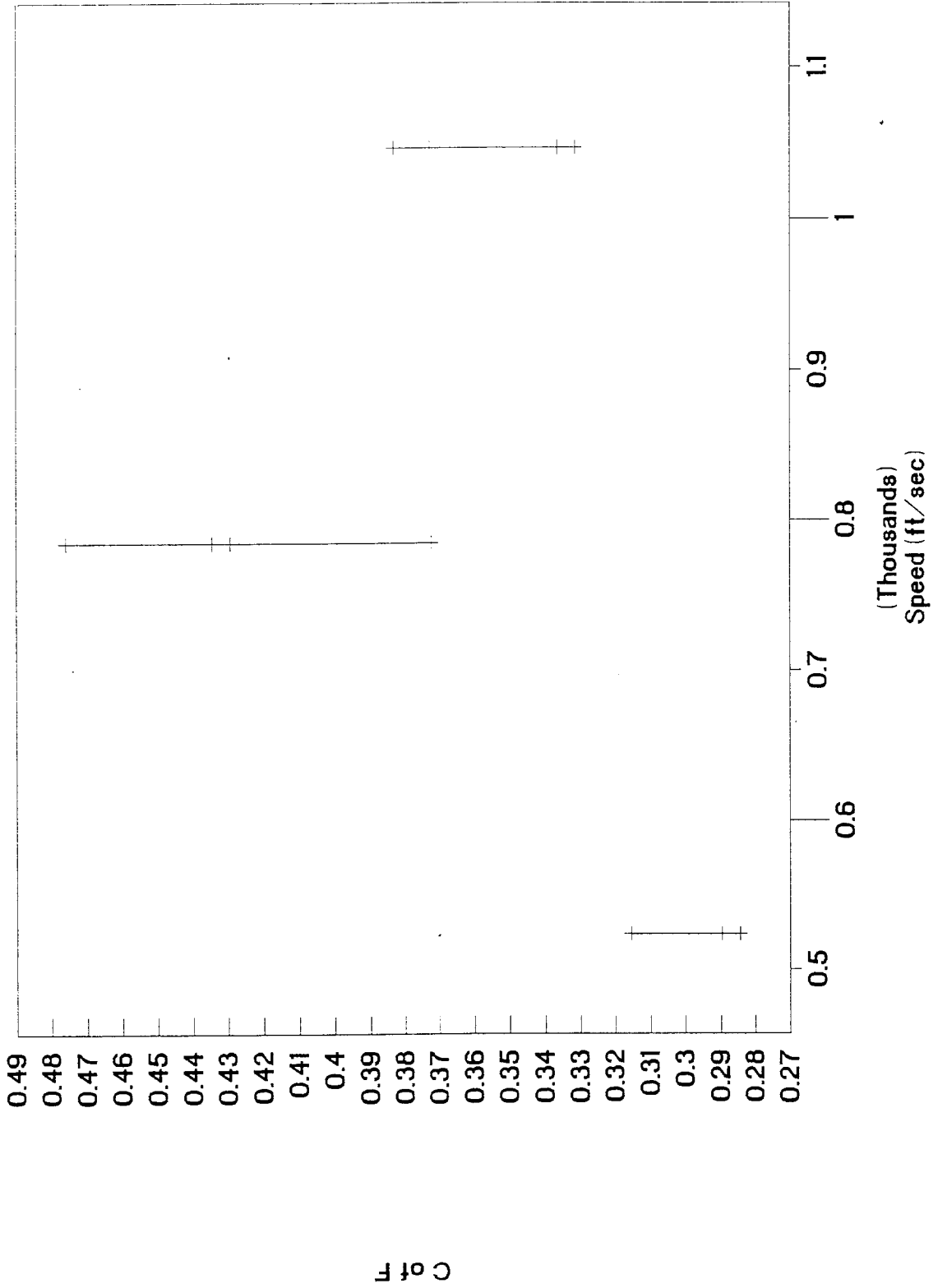

# SiC on Bare Rotor

Ambient Air / Medium Wt.

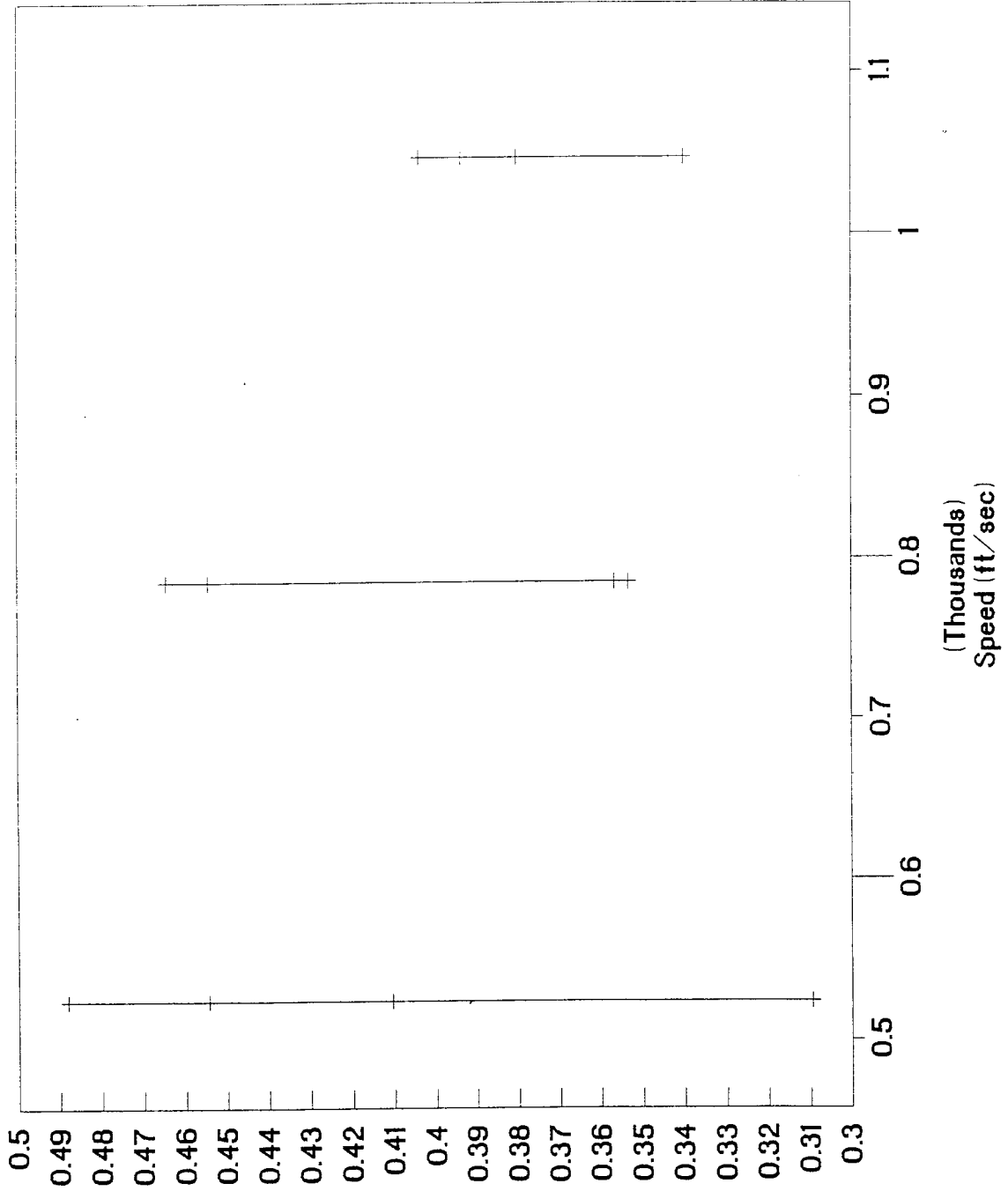

C of F

# SiC on Bare Rotor

Ambient Air / Large Wt.

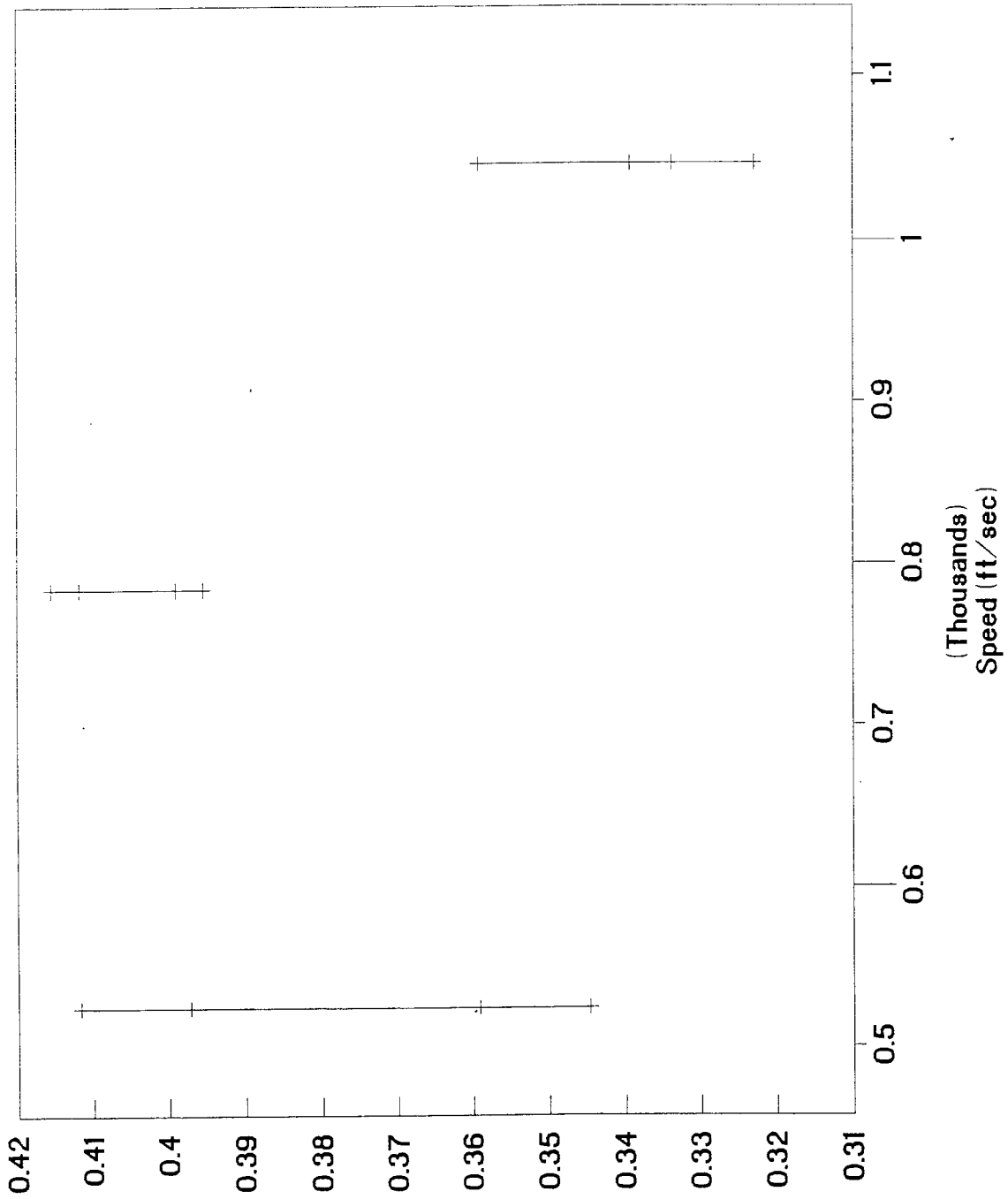

C of F

# TUFT TESTING RESULTS

Part # 10B  
 TUFT #052 - Start thru MD/40  
 Tuft #053 - Remainder

BARE ROTOR  
 AMBIANT AIR TESTING

FIBER/TEST	END TC2(°F)	START TC2(°F)	TEMP CHANGE(°F)	END IC3(°F)	START IC3(°F)	TEMP CHANGE(°F)	END DL	START DL	DL CHANGE IFT WI(g)	START IFT WI(g)	END IFT WI(g)	LOSS(g)	WT (lb)	DRAG (lb)	N (lb)	CI
H25/S20/AMB	94.1	88.9	5.2	101.5	93.5	8.0	0.056	0.003	0.053	13.4503	13.4308	0.0195	0.1075	0.3919	0.2743	
	94.3	92.4	1.9	101.4	95.5	5.9	0.049	0.002	0.051	13.4308	13.4204	0.0104	0.1034	0.3919	0.2639	
	93.6	92.3	1.3	101.0	95.5	5.5	0.047	0.002	0.047	13.4204	13.4151	0.0053	0.0953	0.3919	0.2432	
	93.7	92.0	1.7	101.7	96.0	5.7	0.045	0.001	0.044	13.4151	13.4120	0.0031	0.0892	0.3919	0.2277	
H25/M20/AMB	95.3	92.0	3.3	105.0	96.4	8.6	0.062	0.001	0.061	13.4120	13.4078	0.0042	0.1237	0.6023	0.2054	
	95.3	93.4	1.9	104.2	98.0	6.2	0.063	0.000	0.063	13.4078	13.4048	0.0030	0.1278	0.6023	0.2121	
	96.2	93.4	2.8	104.9	96.7	8.2	0.060	0.002	0.058	13.4048	13.4022	0.0026	0.1176	0.6023	0.1953	
	96.4	94.2	2.2	105.2	98.3	6.9	0.062	0.002	0.060	13.4022	13.4006	0.0016	0.1217	0.6023	0.2020	
H25/L20/AMB	100.3	94.3	6.0	114.7	97.4	17.3	0.126	0.002	0.124	13.4006	13.3947	0.0059	0.2515	1.1178	0.2250	
	103.1	99.5	3.6	117.0	100.4	16.6	0.119	0.002	0.117	13.3947	13.3915	0.0032	0.2373	1.1178	0.2123	
	102.8	101.5	1.3	119.8	102.7	17.1	0.142	0.002	0.140	13.3915	13.3890	0.0025	0.2839	1.1178	0.2540	
	103.0	101.3	1.7	120.0	102.0	18.0	0.139	0.001	0.138	13.3890	13.3872	0.0018	0.2799	1.1178	0.2504	
H25/S30/AMB	112.5	101.9	10.6	127.1	117.8	9.3	0.040	0.001	0.039	13.3872	13.3857	0.0015	0.0791	0.3918	0.2019	
	110.7	90.0	20.7	128.3	118.7	9.6	0.051	0.001	0.050	13.3857	13.3856	0.0001	0.1014	0.3918	0.2588	
	113.9	107.8	6.1	127.8	122.9	4.9	0.044	0.003	0.041	13.3856	13.3839	0.0017	0.0831	0.3918	0.2122	
	115.6	110.4	5.2	128.8	122.8	6.0	0.041	0.002	0.039	13.3839	13.3824	0.0015	0.0791	0.3918	0.2019	
H25/M30/AMB	118.0	111.8	6.2	131.4	122.5	8.9	0.059	0.002	0.057	13.3824	13.3779	0.0045	0.1156	0.6022	0.1920	
	118.7	113.5	5.2	132.0	123.5	8.5	0.061	0.003	0.058	13.3779	13.3751	0.0028	0.1176	0.6022	0.1953	
	118.8	114.8	4.0	132.2	124.1	8.1	0.064	0.003	0.061	13.3751	13.3730	0.0021	0.1237	0.6022	0.2054	
	119.1	114.9	4.2	132.0	123.9	8.1	0.063	0.004	0.059	13.3730	13.3708	0.0022	0.1197	0.6022	0.1987	
H25/L30/AMB	115.2	89.2	26.0	142.8	114.0	28.8	0.136	0.002	0.134	13.3708	13.3664	0.0044	0.2718	1.1178	0.2431	
	114.7	114.7	4.4	144.5	124.4	20.1	0.145	0.002	0.143	13.3664	13.3630	0.0034	0.2900	1.1178	0.2594	
	123.9	118.5	5.4	142.7	125.4	17.3	0.135	0.001	0.134	13.3630	13.3591	0.0039	0.2718	1.1178	0.2431	
	122.1	119.5	2.6	146.0	124.7	21.3	0.149	0.003	0.146	13.3591	13.3553	0.0038	0.2961	1.1177	0.2649	
H25/S40/AMB	123.6	108.8	14.8	141.8	140.3	1.5	0.031	0.000	0.031	13.3553	13.3364	0.0149	0.0629	0.3917	0.1605	
	125.7	117.9	7.8	140.3	137.5	2.8	0.032	0.001	0.031	13.3364	13.3168	0.0196	0.0629	0.3916	0.1605	
	126.2	119.5	6.7	140.7	137.0	3.7	0.032	0.001	0.031	13.3168	13.3024	0.0144	0.0629	0.3916	0.1605	
	127.3	119.7	7.6	142.8	136.7	6.1	0.035	0.001	0.034	13.3024	13.2920	0.0104	0.0690	0.3916	0.1761	
H25/M40/AMB	129.1	120.9	8.2	146.7	137.2	9.5	0.047	0.002	0.045	13.2920	13.2722	0.0198	0.0913	0.6020	0.1516	
	128.6	124.4	6.2	143.0	138.4	4.6	0.043	0.002	0.041	13.2687	13.2561	0.0126	0.0831	0.6019	0.1381	
	129.1	122.1	7.0	144.8	137.8	7.0	0.042	0.001	0.041	13.2561	13.2370	0.0191	0.0831	0.6019	0.1381	
	129.1	122.2	6.9	145.0	137.8	7.2	0.046	0.000	0.046	13.2370	13.2197	0.0173	0.0933	0.6019	0.1550	
H25/L40/AMB	112.7	122.3	-9.6	162.5	139.4	23.1	0.140	0.000	0.140	13.3300	13.3090	0.0240	0.2839	1.1176	0.2540	
	116.8	126.3	-9.5	160.8	142.0	18.8	0.117	0.002	0.115	13.3090	13.2959	0.0131	0.2332	1.1176	0.2087	
	109.1	82.4	26.7	159.6	127.7	31.9	0.105	0.001	0.104	13.2959	13.2843	0.0116	0.2109	1.1176	0.1887	
	118.0	121.0	-3.0	162.0	141.5	20.5	0.112	0.000	0.112	13.2843	13.2749	0.0094	0.2271	1.1176	0.2032	

**NOTES:**

- TC2 - Thermocouple located after the tuft slightly above the rotor.
- TC3 - Thermocouple located before the tuft slightly above the rotor
- DL - Drag Load (lbs @ 6.085 in. radius)

H25 - HAYNES 25 FIBERS  
 20 - 20,000 RPM's  
 30 - 30,000 RPM's  
 40 - 40,000 RPM's

AMB - Ambient Air (no flow)

S - Small Weight 164.30g  
 M - Medium Weight 259.73g  
 L - Large Weight 493.56

CF - Coefficient of Friction

FILE: TTRPNAHA

# Haynes 25 On Bare Rotor

Ambient Air / Small Wt.

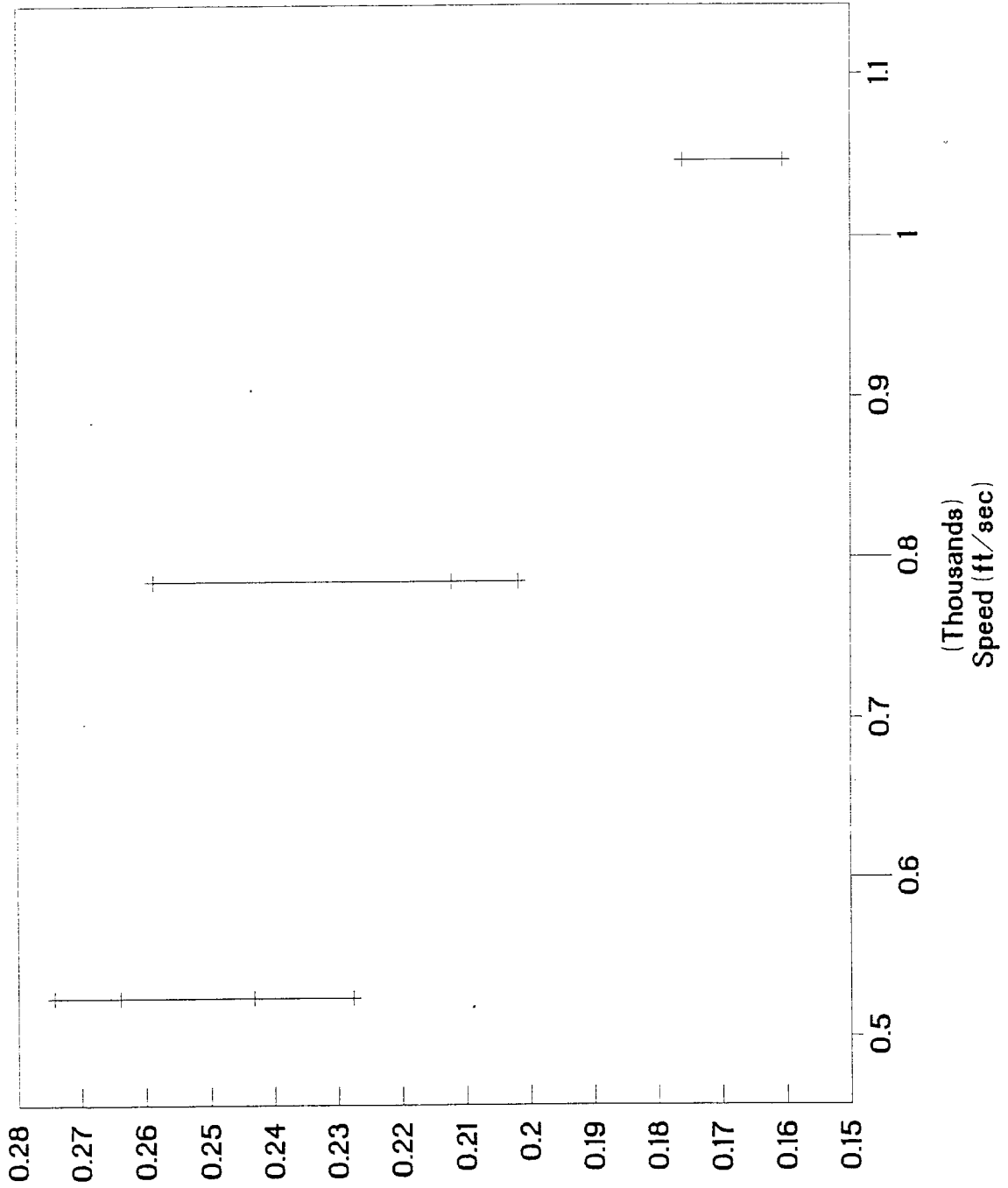

# Haynes 25 On Bare Rotor

Ambient Air / Medium Wt.

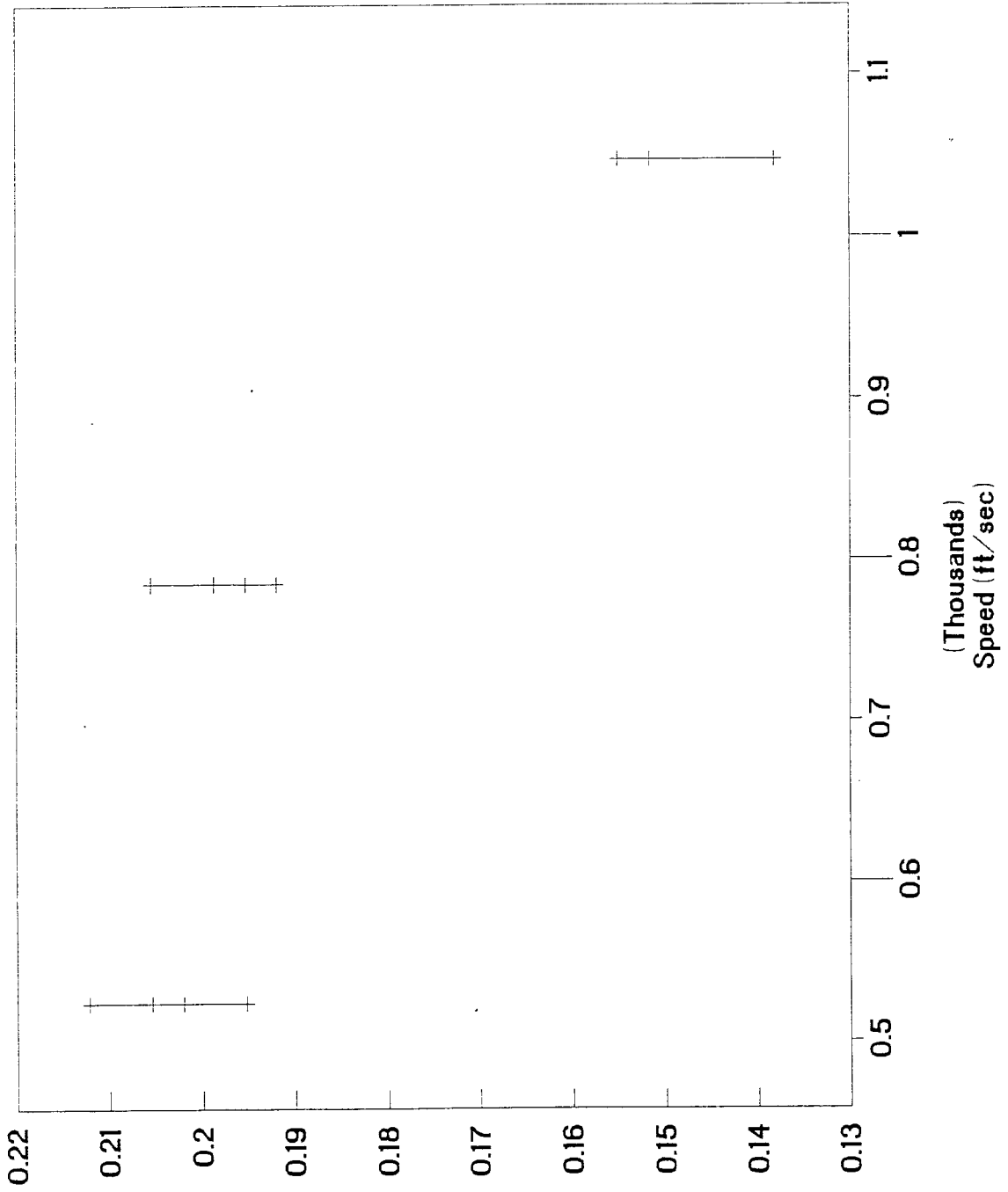

CoF

# Haynes 25 On Bare Rotor

Ambient Air / Large Wt.

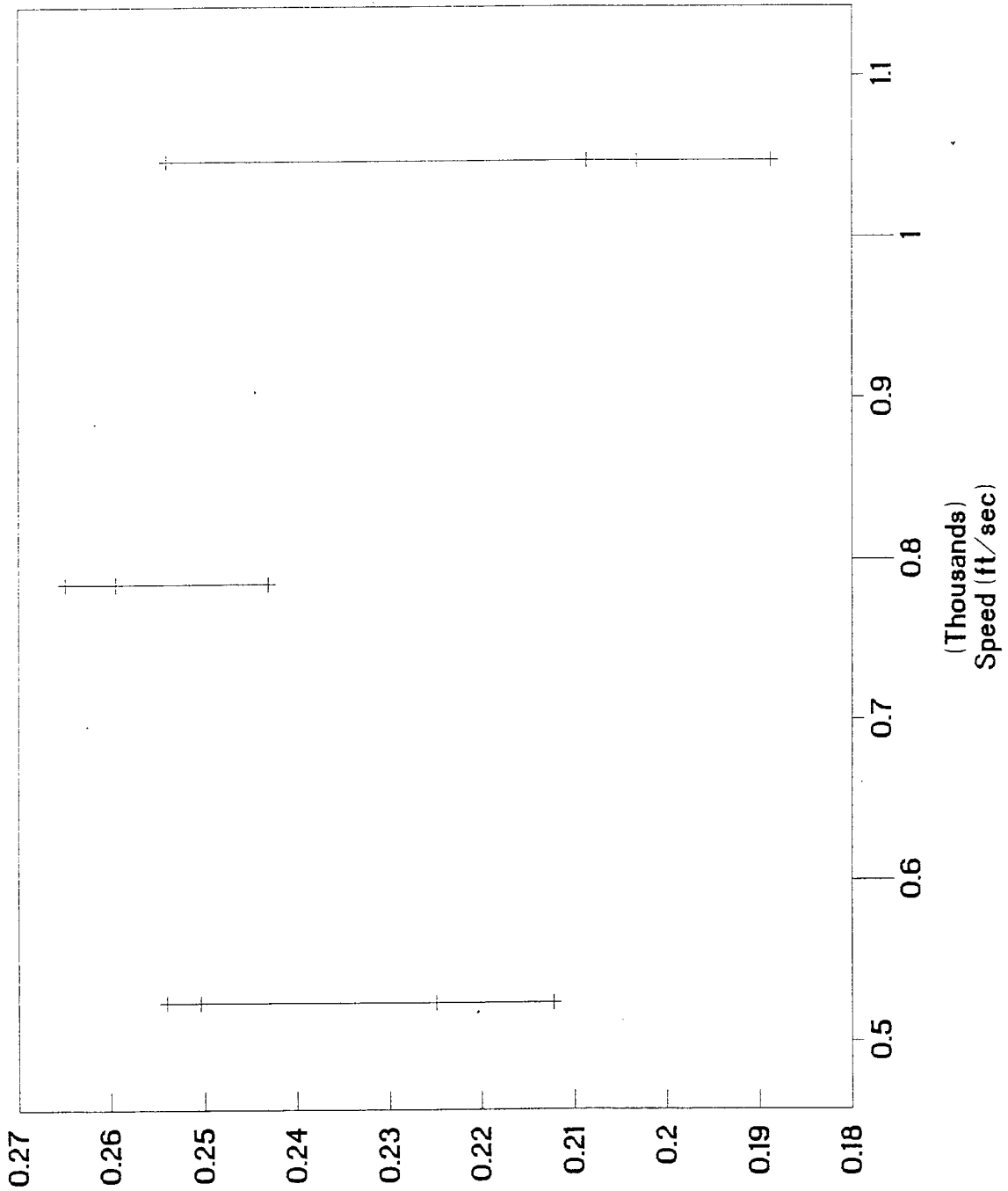

C of F