

U.S. Army - Baylor University Graduate Program
in Health Care Administration

Graduate Management Project
Development of a Computer Simulation Model For a
Community Hospital Emergency Department

Submitted to
Colonel Ira F. Walton III, MS
and
Lieutenant Colonel Michael H. Kennedy, MS
in Partial Fulfillment of Requirements for
HA 5661: Administrative Residency
by
Major Timothy D. Reese, AN

Accession For	
NTIS CRA&I	<input checked="" type="checkbox"/>
DTIC TAB	<input type="checkbox"/>
Unannounced	<input type="checkbox"/>
Justification _____	
By _____	
Distribution /	
Availability Codes	
Dist	Avail and/or Special
A-1	

Fort Benning, Georgia

27 May 1994

19950405 060

REPORT DOCUMENTATION PAGE

Form Approved
OMB No. 0704-0188

Public reporting burden for this collection of information is estimated to average 1 hour per response, including the time for reviewing instructions, searching existing data sources, gathering and maintaining the data needed, and completing and reviewing the collection of information. Send comments regarding this burden estimate or any other aspect of this collection of information, including suggestions for reducing this burden, to Washington Headquarters Services, Directorate for Information Operations and Reports, 1215 Jefferson Davis Highway, Suite 1204, Arlington, VA 22202-4302, and to the Office of Management and Budget, Paperwork Reduction Project (0704-0188), Washington, DC 20503.

1. AGENCY USE ONLY (Leave blank)		2. REPORT DATE MAY 1994	3. REPORT TYPE AND DATES COVERED FINAL REPORT (07-93 TO 07-94)	
4. TITLE AND SUBTITLE DEVELOPMENT OF A COMPUTER SIMULATION MODEL FOR A COMMUNITY HOSPITAL EMERGENCY DEPARTMENT			5. FUNDING NUMBERS	
6. AUTHOR(S) CPT TIMOTHY D. REESE, AN			8. PERFORMING ORGANIZATION REPORT NUMBER 11a-94	
7. PERFORMING ORGANIZATION NAME(S) AND ADDRESS(ES) MARTIN ARMY COMMUNITY HOSPITAL FORT BENNING, GA			10. SPONSORING/MONITORING AGENCY REPORT NUMBER	
9. SPONSORING/MONITORING AGENCY NAME(S) AND ADDRESS(ES) US ARMY MEDICAL DEPARTMENT CENTER AND SCHOOL BLDG 2841 MCCS HRA US ARMY BAYLOR PGM IN HCA 3151 SCOTT ROAD FORT SAM HOUSTON TEXAS 78234-6135			11. SUPPLEMENTARY NOTES	
12a. DISTRIBUTION/AVAILABILITY STATEMENT APPROVED FOR PUBLIC RELEASE: DISTRIBUTION IS UNLIMITED			12b. DISTRIBUTION CODE	
13. ABSTRACT (Maximum 200 words) The purpose of this study was to develop a simulation model for Martin Army Community Hospital that will dynamically assess the effects of proposed changes in the Emergency Department (ED) resource allocation, such as staff or beds, or changes in processes, duration, or frequency will have on patient access to the ED. A computer model of the ED was built using GPSS/H which represents the patient flow and resource allocation of the MACH ER. An interface for the naive user was built using Lotus 1-2-3 for Windows. The interface provides help and guidance for the user to change or manipulate any or all of over 90 variables in the model, run the simulation, and view charts and graphs based on the outcome measurements.				
14. SUBJECT TERMS EMERGENCY DEPARTMENT (ED); SIMULATION MODEL			15. NUMBER OF PAGES 79	
17. SECURITY CLASSIFICATION OF REPORT N/A			16. PRICE CODE	
18. SECURITY CLASSIFICATION OF THIS PAGE N/A		19. SECURITY CLASSIFICATION OF ABSTRACT N/A		20. LIMITATION OF ABSTRACT UJL

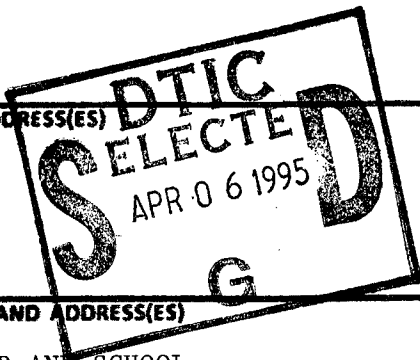

"I can do all things through Christ which strengtheneth me."

- Phillipians 4:13

ACKNOWLEDGEMENTS

My gratitude extends deeply to so many people who assisted, cajoled, prodded, and carried me through this project.

The didactic background provided in the residence phase of the U.S. Army - Baylor Program provided me with much of the knowledge, skills and abilities to complete this task. Martin Army Community Hospital boasts of being the best community hospital in the world--for good reason. It is a center of excellence serving the Army's Best Installation for 1994, Fort Benning. The staff and leadership of this facility give so much of themselves to provide the very best care possible. They supported my efforts and gave to me the time, resources, and benefit of their experience which were necessary to build this model.

The love and support provided in early childhood extends throughout life. For that strong foundation, and their continued sustenance I thank my father and mother, Victor and Margaret Reese; my brothers, Michael and David; and my sisters, Gina Reese and Kym VanHorne.

These two years of study have taken their toll on all those close to me, but no more so than on my lovely, patient and beautiful wife, Lorri, and four wonderful children, McKenna, Brittany, Alexis, and Evan. Their patience and constant prayerful support have made it possible for me to continue.

I must acknowledge the Creator of all things, for it is the Lord who provides the gifts, talents, and opportunities for all success. I thank Him for providing the clarity of mind and will to do my very best in this and all of my endeavors.

ABSTRACT

Today's health care organizations place emphasis on three components of the delivery system—quality of care, cost, and patient satisfaction. The military medical organization has increased its focus on these same components over the past decade.

The purpose of this study was to develop a simulation model for Martin Army Community Hospital that will dynamically assess the effects of proposed changes in ED resource allocation, such as staff or beds, or changes in processes, duration, or frequency will have on patient access to the Emergency Department.

A computer model of the ED was built, using GPSS/H[®] that represents the patient flow and resource allocation of the MACH ER. An interface for the naive user was built using Lotus 123 for Windows[®]. The interface provides help and guidance for the user to change or manipulate any or all of over 90 variables in the model, run the simulation, and view charts and graphs based on the outcome measurements.

This project will help the Emergency Department management team evaluate how different processes influence the patient wait, thereby, influencing patient satisfaction. The results provide a strong argument for the continued testing and use of this model and of building the database required to more accurately represent the existing conditions. The significance of these results are that, though they do not paint the precise picture of the ED, they provide the basis on which to continue to work. The interface and model program written are user friendly and a potentially valuable tool in Martin Army Community Hospital's continued efforts toward improving quality and access, while minimizing costs.

TABLE OF CONTENTS

LIST OF TABLES	v
LIST OF FIGURES	vi
CHAPTER ONE	1
INTRODUCTION	
Existing Conditions	2
Problem Statement	6
Literature Review	6
Purpose	12
CHAPTER TWO	13
METHOD AND PROCEDURES	
Data Collection	13
Building the Model	18
Validity and Reliability	19
Ethical Considerations	22
CHAPTER THREE	24
RESULTS	
CHAPTER FOUR	34
DISCUSSION	
CONCLUSIONS	36
REFERENCES	37
APPENDIX A	40
GLOSSARY OF TERMS	40
APPENDIX B	42
DISCUSSION OF THE MODEL AND INTERFACE	42
The Interface	42
The Model	43
Memory	48

APPENDIX C	50
SCREENS OF THE SPREADSHEET INTERFACE	50
APPENDIX D	62
HOW TO LOAD AND RUN THE SOFTWARE	62
APPENDIX E	63
SOURCE CODE FOR GPSS/H MODEL	63
FLOW DIAGRAMS	63
SOURCE CODE	73

LIST OF TABLES

Table I	Descriptive statistics on patient interarrival times using 6-hour blocks .	24
Table II	Correlation of time of day to IA time	25
Table III	Correlation of IA time to season.	26
Table IV	Fitting the IA times with an exponential curve	28

LIST OF FIGURES

Figure 1	Layout of the current Emergency Department.	3
Figure 2	Process Flow Diagram	14
Figure 3	Interaction of Emergency Department with other healthcare providers	15
Figure 4	Patient arrival fluctuations by day	16
Figure 5	Patient arrival fluctuations by hour	16
Figure 6	Emergency Room visits compared with patients waiting more than 3 hours	20
Figure 7	Emergency Room visits compared with patients waiting more than 1 hour	20
Figure 8	Cummulative distribution functions for weekday IA	27
Figure 9	Cummulative distribution functions for weekend IA	28
Figure 10	Physician and Physician Assistant staffing patterns	31
Figure 11	Nursing personnel staffing patterns	32
Figure 12	Sample data file for staffing matrix	45

CHAPTER ONE

INTRODUCTION

Today's health care organizations place emphasis on three components of the delivery system—quality of care, cost, and patient satisfaction. The military medical organization has increased its focus on these same components over the past decade. This emphasis has become more evident as military medicine enters the competitive environment of managed care. All areas within the military hospital must strive to provide the most efficient, highest quality care, while monitoring the recipients' perception of the services rendered. The Army Medical Department (AMEDD) stresses these elements under the concepts of Quality, Cost, and Access.

There are few areas within the Army community hospital where these goals are more difficult to achieve than the Emergency Department (ED). Many factors impede the ED manager's efforts in meeting the varied and complex needs of their patients. The operating cost of the ED is affected by the efficiency of resource management and the utilization patterns of patients.

The application of Operations Research tools, such as computer simulation, has proven beneficial in hospital resource management. Many studies have shown valuable gains through the use of such tools in staffing allocation, more efficient patient flow, and cost efficiencies (Saunders 1987).

This management study focuses on creating a tool for the Martin Army Community Hospital ED to determine the optimal mix of resources. The primary goal is to develop a tool that can be used by the ED management to minimize overall patient throughput times.

Existing Conditions

Martin Army Community Hospital (MACH) is a 176-bed general, community hospital located at Fort Benning, Georgia. It serves a population of over 80,000 active duty, retiree and family member beneficiaries. The capabilities of the facility compare with that of most community hospitals, providing general medical, surgical, and obstetric care. MACH also provides extensive primary and specialty outpatient care to the same population. It augments required services by transferring patients to local, civilian health care facilities. MACH was accredited, with commendation, in 1992 by the Joint Commission on Accreditation of Healthcare Organizations (JCAHO). The Emergency Department is categorized as a Level II facility (Cross et al 1993), described minimally by the JCAHO (1993) as offering "emergency care 24-hours a day, with at least one physician experienced in emergency care on duty in the emergency care area, and with specialty consultation available within approximately 30 minutes by members of the medical staff or by senior-level residents." It is also affiliated with a Family Practice Graduate Medical Education program.

The MACH ED operates on a volume of 115 to 170 visits each day—over 48,000 per year. Five percent of the visits result in admission to the hospital and the

ED accounts for over 25% of MACH's total admissions. The ED was remodeled several years ago and provides a fairly clear path for most patient operations (Figure 1).

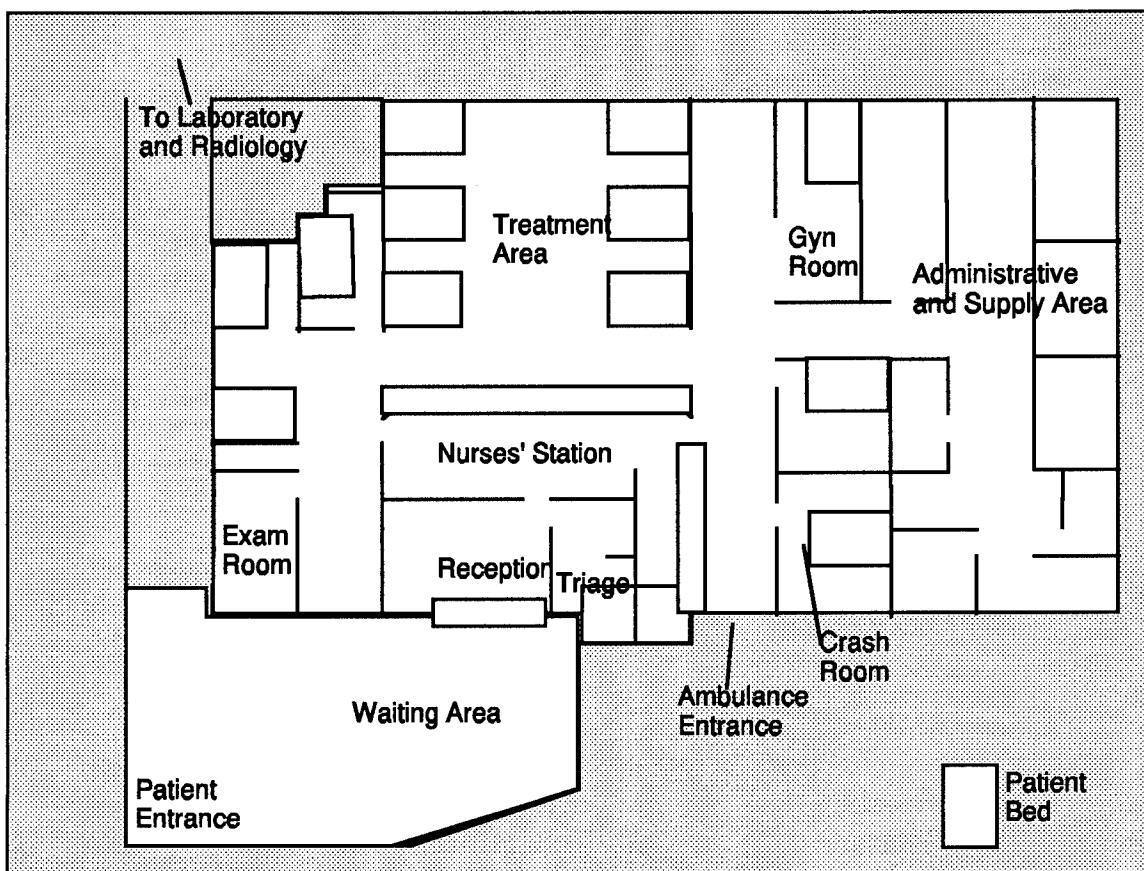

Figure 1 Layout of the current ED, showing 11 regular beds and 1 crash/trauma bed.

The Department of Defense patient classification system allows for three categories of patients, Emergent, urgent, and non-urgent, in the ED. Emergent is defined as life or limb critical. The patients require immediate secondary medical intervention to prevent the loss of life, organs, or limbs. The urgent category is defined as a patient that needs immediate medical intervention to keep their condition from worsening and becoming Emergent. These patients are in danger of losing

function or their condition is such that delays in treatment may result in poorer long term restoration of health. Non-urgent patients are primarily ill or injured in such a fashion that delays in treatment will not result in a poorer outcome, or loss of function. Normally, it is appropriate for non-urgent patients to seek care at their primary physician, not the ED. Since the MACH ED is not a trauma center for the local community, the average acuity of patients ranges much farther to the minimal, or non-urgent category than reflected in urban EDs. Cross found that non-urgent patients account for 80% of the volume, with urgent patients representing 19% and emergent patients only 1% .

The Emergency Department at MACH is located organizationally within the Department of Family Practice and Community Medicine. This department is responsible for the efficiency and operational standards of the ED. They have reviewed these standards over the past several years to evaluate the efficiency. Patient waiting times and length of stay in the ED are the primary indicators monitored. The standards under which it is expected to operate are driven by the Health Services Command (HSC), the parent organization for MACH. The HSC standard for the time a patient waits prior to being seen by a credentialed provider is less than one hour. The standard for total length of time within the ED, from sign-in to discharge, transfer, or admission, is less than three hours. Historically, waiting times and the length of time spent in the ED have been a significant source of discontent for our beneficiaries (Castro 1993). Official complaint rates for waiting times at MACH have decreased over the past several months, but perceptions of long waits remain with many

beneficiaries (MACH 1993). Continuous monitoring indicates that the majority of our patients are served within the standard times—with only 5% to 26% staying over three hours, and fewer than 35% waiting more than one hour for initial evaluation by a credentialed provider (Cross et al 1993). ER personnel report that when fewer than 10% of the patients wait beyond the standards set, the operation of the ED is perceived as efficient, whereas, when more than 35% of the patients wait more than the proscribed time intervals, complaints rise to astronomical levels.

Study results and management perceptions of inefficiencies have prompted changes in the management of the ED. These changes have met with mixed success. Efficiency studies of contract physicians in the ED showed much lower rates of patients seen per provider than their military and civilian staff counterparts. This prompted consideration of termination of the contract and a shift to organic providers (Cross et al 1993).

More than 35% of the patients seen in the ED are under 17-years of age. An after-hours pediatric clinic was implemented in October of 1993. It operates on weekdays between the hours of 4:00 pm and 7:30 pm. Scheduling difficulties and support arrangements initially hampered the effectiveness of this program. Follow-up measurements have been inconclusive on its overall effect. Perceptions of the ED staff indicate that it is helpful to them.

Current initiatives are underway to augment the ancillary staff of the ED, as well as designate a Registered Nurse triage officer. These plans are aimed at decreasing waiting time as well as increasing the throughput of patients.

Problem Statement

Martin Army Community Hospital does not have any standard management tools to determine the effect of proposed changes in resource allocation to the Emergency Department. Changes in resources, technology, and policy have been made over the past several years based on valid management studies, but without any real means of measuring their effects, short of replicating the original time consuming studies. The Emergency Department needs a means to model the effect of proposed changes in resource allocation, technology and management.

Literature Review

Emergency Departments are universally associated with long patient waits. Even a brief literature search on the topics of patient waiting and Emergency Departments draws articles from nearly every developed country, including Hungary, the former Soviet Union, England, Canada, Taiwan, and the United States. Reviews of the literature find a plethora of correlated factors to long waits, many of the studies in contradiction with others. A common thread among them is that long waits, regardless of their cause, are a major source of patient dissatisfaction.

Dissatisfaction is expressed in the commercial market by patients choosing other providers of health care. That choice is predicated on the availability of other options. Many patients in the United States do not have health insurance and the Emergency Department may be their only portal of entry for health care (Bindman et al 1991). Patients "locked in" to a specific system of health care, such as a Health Maintenance Organization, or the Department of Defense Medical System do

not have as free an option to seek urgent or after-hours care elsewhere. Designated provider hospitals, usually specified by the patient's health care plan, are the only options they have for most after-hours care.

In health care systems where resources are constrained and there are no financial disincentives to seeking care, such as is the case with the Department of Defense Medical System, queues can serve as allocators (Bloom and Fendrick 1987). Increasing the availability of care or resources available to provide care has not always been the answer to preventing queues. It has been shown that in many systems where money is not a means of gaining access to the health care system, the demand will increase to meet the supply available (Swiderski 1990). Most patients are capable of determining the level of their health care needs and make appropriate decisions about waiting in the ED or leaving, but some patients are put at risk by long waits. Long waits can potentially jeopardize the health of patients in two ways—delay urgently needed care and delay patients seeking care until their condition is very poor (Bindman et al 1991) (Smeltzer 1986).

Studies of patient satisfaction have demonstrated a negative correlation with the length of time they wait for care. Burstein and Fleisher (1991) found that 18% of all patient complaints in the ED were related to waiting. Bursch et al (1993) found five factors that were strongly correlated to patient dissatisfaction. The total time that the patients spent in the ED was the primary causal agent found in their study. Other studies confirm that patients don't like to wait for care (Smeltzer 1986) (Castro 1993).

Establishing an appropriate amount of time for a patient to wait in the ED appears to be a difficult proposition for both administrators and clinicians. Two time or duration periods are most reported—the time a patient waits to be seen by the physician and the total time a patient stays in the ED. As mentioned before, the Army has standards set by higher headquarters regarding these two parameters. The goals are set at one hour and three hours, respectively. Civilian researchers show data for these standards as well. Smeltzer (1986) reports an average ED visit of two and one-half hours for patients, with 26.3% remaining over three hours. In a very small ED, Swiderski (1990) found 12.4% of the patients remaining over three hours. In another study, 26% of the patients stayed in the ED over three hours, and 29% waited over one hour to see a physician (Abramowitz et al 1989). Dickinson (1988) reported an average wait to see a physician of 66 minutes. Bindman et al (1991), commented that one of the patients participating in their study had waited 17 hours to be seen by a physician! The current statistics for our ED show an average of 30% of the patients waiting over one hour to be seen, and 15% of the patients remaining in the ED for more than three hours.

Many independent variables have been associated with long waits in the ED. Laboratory studies, radiology exams, and specialty consultations have been correlated in several studies (Castro 1993) (Saunders 1987) (Wilbert 1984). Other researchers have attributed longer waits to staffing (Swiderski 1990), patient census (Abramowitz et al 1989) (Dickinson 1988), and slow hospital admission procedures (Wilbert 1984). Some studies evaluated the effect of the patient's acuity, or severity of illness, on the

length of wait and treatment. The findings have been mixed, but the generally reported impact of acuity is that the lower the severity of illness, the longer the patient will wait to see the physician, but also that those patients will remain in the ED for a briefer period overall (Hu 1993) (Saunders 1987). Smeltzer (1986) and Castro (1993) found no correlation between patient acuity and the length of their treatment or wait to be seen.

Other processes critical to evaluation of the ED are the times patients wait for ancillary services such as consults and laboratory or radiology studies. Castro (1993) found that the MACH ED requests laboratory studies on 29% of the patients seen, with a mean wait for testing and results of 62 minutes. Twenty-four percent of the patients receive radiology exams and wait an average of 55 minutes for those results. Though the waiting time was not examined, only five percent of ED patients required medical consults. These findings compare with those reported in the literature. Smeltzer (1986) reports 36% requiring laboratory tests, 39% requiring radiology exams, and 28.1% needing specialty consults. Other studies show the average waits for laboratory studies between 77 minutes and 90 minutes (Swiderski 1990).

Many operations research (OR) methods have been used to study Emergency Departments and services. Time and motion studies predate any other method of research in this field. This method, at least in part, accounts for the majority of studies reviewed. Where it used to be the primary research tool, with the advent of faster, more powerful, and more attainable computers, this method has been relegated to being a smaller part of either mathematical modeling or computer simulation. Time

and motion techniques can demonstrate overall effectiveness, but they are unable to attribute causal agents to improvements made in efficiency (Thorpe 1972). These techniques do not allow the researcher to predict or forecast operations and limit the application of the findings (Saunders et al 1989).

Another common set of OR tools brought over from industry to the health care setting are mathematical and queuing models. With the use of these tools, improvements in operations have been found in some settings (Ahituv and Berman 1987) (Baligh and Laughhunn 1969) (Lohr 1984). Lusk (1980) suggests that trending formulas may be applied to the ED to predict patient flow. Forecasts may be attainable through the process of trending admission rates and deseasonalizing the data for development of an appropriate regression formula. The difficulty of effectively using these models is that they can not account for the complexity of the ED. None of the techniques described can accommodate patient renegeing (leaving without being seen), simultaneous tasks, multiple servers, dependent tasks, or a preemptive priority patient classification system (Saunders et al 1989) (Swiderski 1990).

The application of computer technology to the ED has met with tremendous success. Simple applications, such as monitoring selected tasks have led to identification of bottle-necks and subsequent improvements in patient flow (Hu 1993). The use of computer simulation allows manipulation of the processes without the delays, cost, and potential harm to patient relations that the other techniques require. Sophisticated computer modeling has helped construct new systems and redesign existing Emergency Departments. Hours, days, months and even years worth of data

can be gathered in a short term, testing the long-term effects of proposed changes or designs. Saunders (1987) developed a very detailed model of an ED for a large hospital. Over thirty elements, services, and operations were tested with this model to improve patient flow and decrease operational costs. Swiderski (1990) modeled a small ED with the findings that adding only one bed would improve access more than increasing any combination of physicians, nurses, or clerks. Studies have shown that Emergency Departments, though complex in nature, have many predictable elements suitable for computer simulation (Walrath 1983) (Valenzuela et al 1990).

To build a model that has predictive capabilities, the patterns of behavior of patient arrival must be examined. Previous studies have shown differences in ED visits by time of day (Bindman et al 1991) (Pachter et al 1991), day of week (Booth et al 1992) (Wilbert 1984) (Abramowitz et al 1989), and seasonal, or monthly cycles (Lusk 1980). Wilbert (1984) established evening hour peaks in patient visitations. Other researchers show mid-day and week-end increases in volume. This attribute may vary according to the unique nature of a given facility, though some generalized patterns may be established. Pachter et al (1991), reported a majority of pediatric visits during the evening hours. Evening visits to the ED can be attributed to lack of other health care options, lack of transportation during the day, increased awareness of illness, and individual priorities.

Purpose

The purpose of this study was to develop a simulation model for Martin Army Community Hospital that will dynamically assess the effects of proposed changes in ED resource allocation, such as staff or beds, or changes in processes, duration, or frequency will have on patient access to the Emergency Department. These changes can result from changes in treatment protocol, or be the result of new technology. Previous efforts at improving the operations or efficiencies of the Emergency Department have been moderately successful, but the measurement of this success is difficult in the short term. Implementation of change requires an adjustment period of some degree. Quantitative analysis of each change would require a management study several months or even a year following each change. Furthermore, analysis of two or more simultaneous changes in operations is obscured by the effects of each action, leaving the manager with a less clear understanding of the value of each change. Development of a valid simulation model will allow immediate analysis and will not require additional expenditures of scarce resources.

CHAPTER TWO

METHOD AND PROCEDURES

Valid simulation of complex processes requires extensive data collection and analysis. The plan used in this study accounts for the variances of treatment times, patient arrivals, and staffing fluctuations throughout the day, day of the week, monthly and seasonal periods. Comparison of the finished model to actual data, necessary for validation, was then performed. This plan provided for collection of baseline data on throughput times and delays found within the system. Statistical analysis of this baseline data was then compared to that of the model output for further validation.

Data Collection

Four primary elements are required to build an accurate process model; process flow diagram (PFD), inter-arrival times (IA), process duration times (DT), and probabilities of occurrence (PR). Each of these provides necessary information to the programmer to develop a representation that approximates reality. Variances occur within each of the elements and must be accounted for. The level at which the model is detailed dictates the level of data collection. In other words, if the analyst desired to exactly mirror the working environment, he would collect data on each individual in the process, and build the model to account for each person's particular input, by name. In contrast, most studies of this nature focus on average performance

specifications for *classes* of persons. An example in this study is the collection of data on the performance specifications for *Nursing Staff* as a group.

The first required element is a process flow diagram, or map of the processes involved. Evaluation of the patient flow patterns and possible courses through the system is required for building the structure of the model. This element was developed through observation of the ED and support activities (eg. lab), interviews of

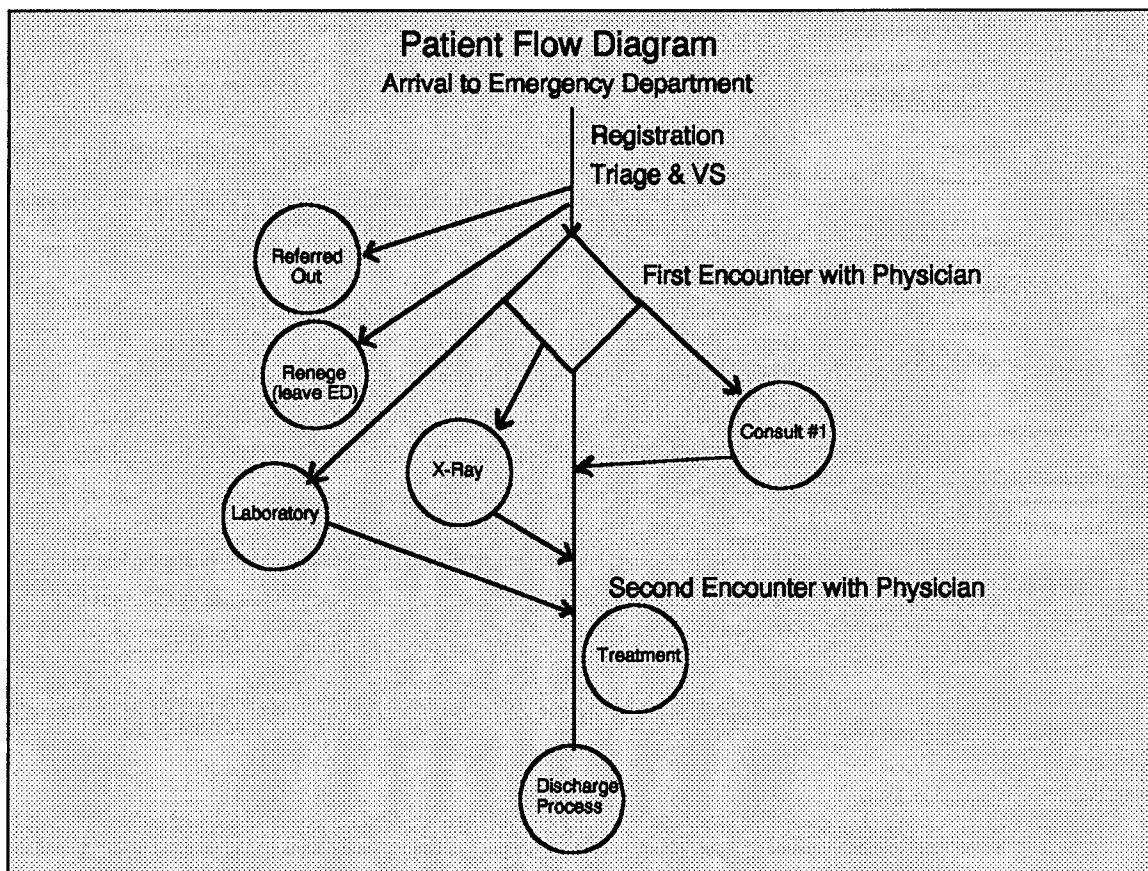

Figure 2 Process Flow Diagram

the staff, and a review of written records. The PFD used in this project is shown in Figure 2. The interactions of the ED with other clinics and facilities, as well as the potential sources of patients or post disposition alternatives are diagrammed in Figure 3.

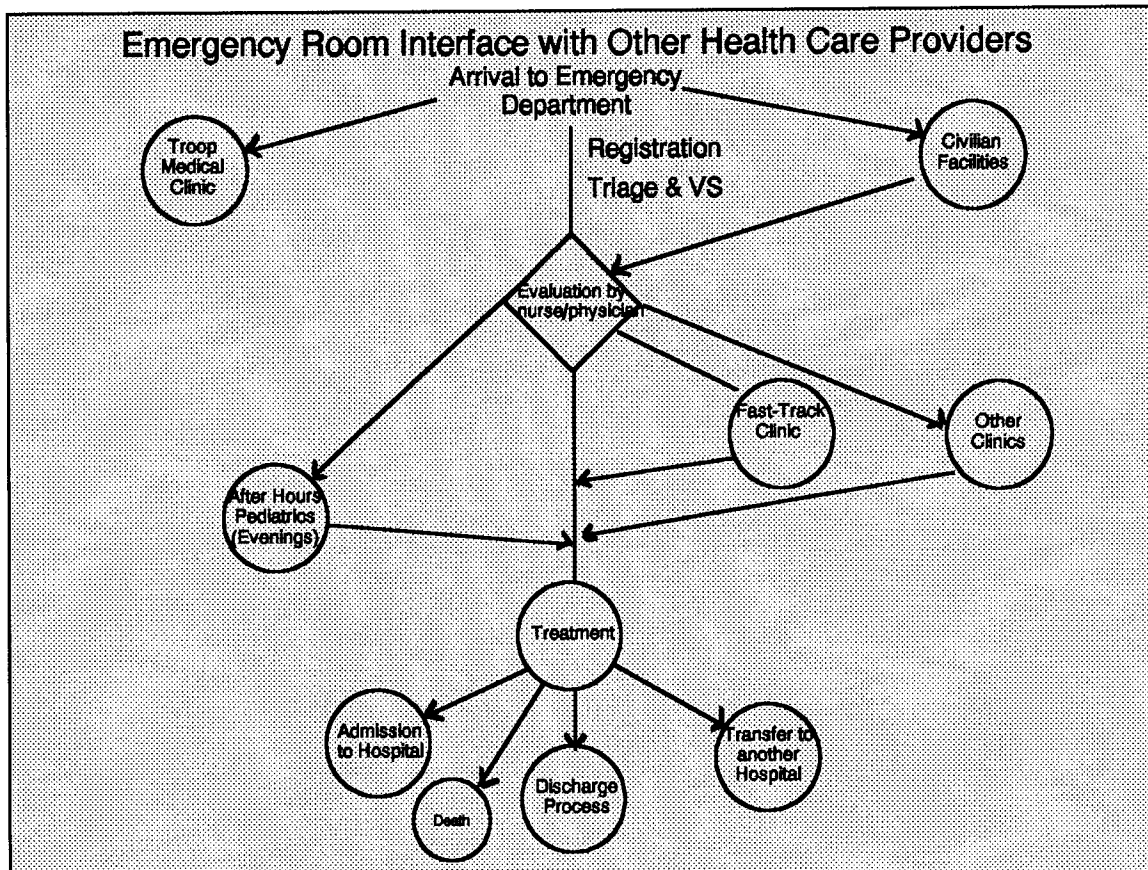
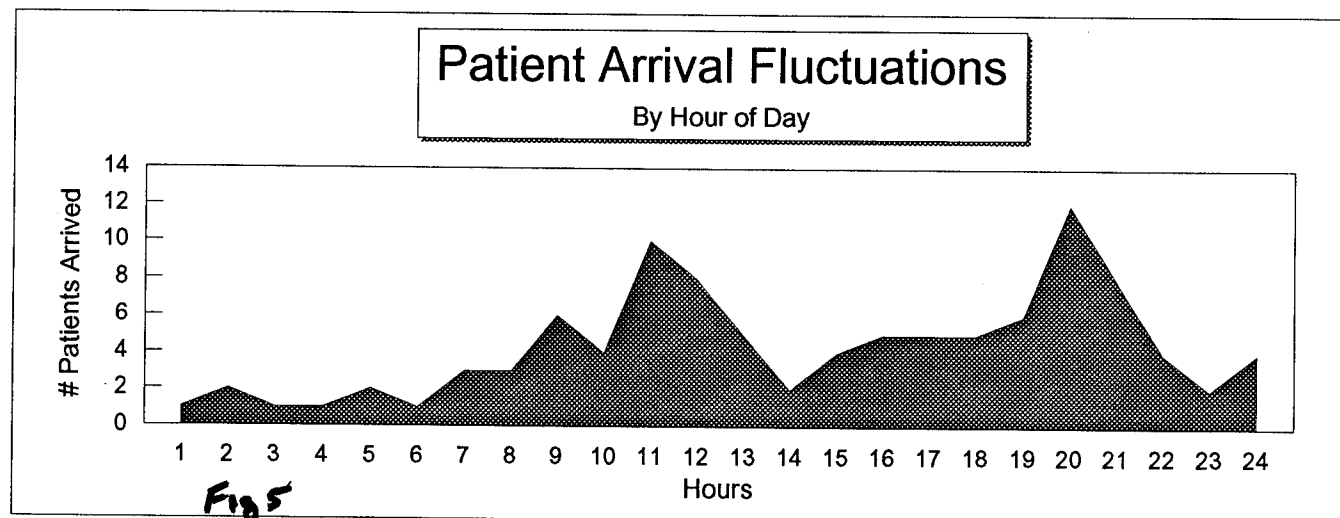
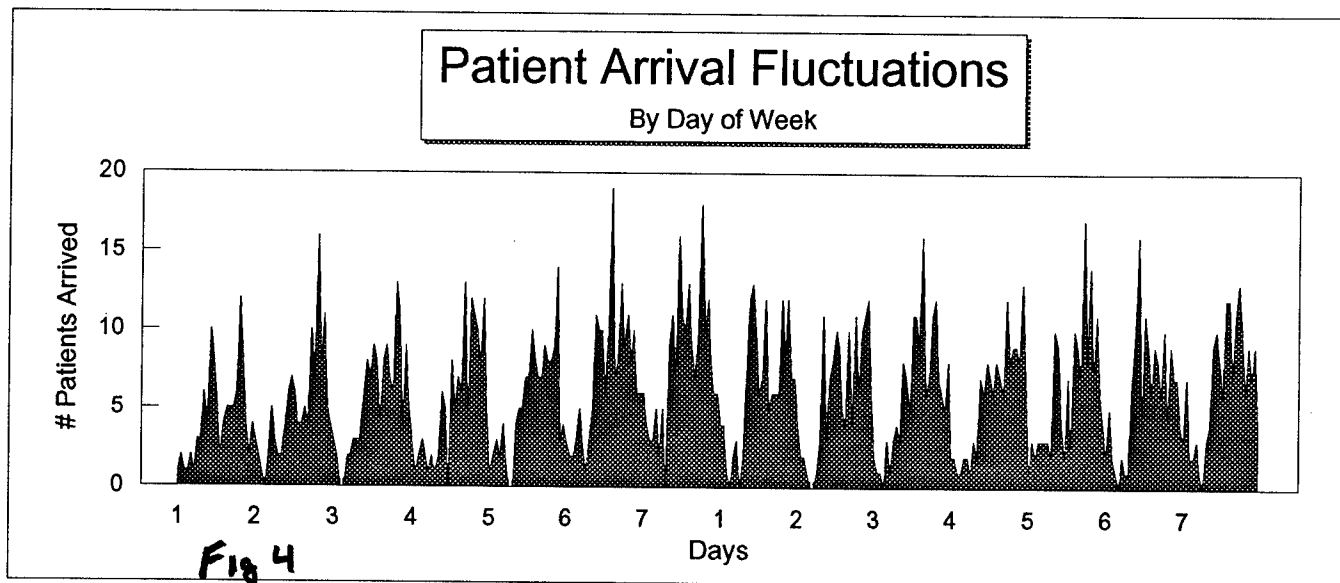

Figure 3 Interaction of Emergency Department with other healthcare providers

The second required element is patient interarrival time. This is the time period between the arrival of each patient to the emergency room. Fluctuation in this element compounds the difficulty of model development. The ED ordinarily has numerous peak and valley interarrival periods throughout the 24-hours of operation each day. These periods often vary further between weekdays and weekends, as well as seasonally. Figures 4 and 5 demonstrate the IA time fluctuations found on a daily and weekly basis. In order to account for these variances, I collected 25% of the data for the 12 months between November 1992 and October 1993, using randomly selected days. The data was found in the Automated Quality of Care Evaluation



Support System (AQCESS). The downloaded ER log sheets were then converted into a spreadsheet and ASCII flat files for analysis of the patient interarrival periods. The compiled data was then further organized into four 6-hour periods for each day, beginning at 12 o'clock Midnight, and separated into weekday and weekend periods. To more closely imitate the normal fluctuations in IA times during the day, the data was then analyzed in one hour increments. The day of the week, month of year and seasonal analyses were completed on the IA times.

The duration of each identified process in the PFD is the third element of data required for accurate simulation. The baseline for some of these processes are those gathered by Castro (1993), in his evaluation of the MACH ED. This project initially proposed to include a complex time study of many processes within the ED. Due to an acute staffing shortage and concurrent increase in patient load, only two of the processes were closely examined. It was decided by the ED management staff that short time studies could be performed on the triage and patient registration processes without adversely impacting patient care.

Given the wide variety of patients seen in the ED, as well as the complexity of patient care processes, the fourth major data element necessary is the probability of each process' occurrence. Each patient varies in nature, illness type, and severity from other patients. The course of each patient's evaluation and treatment will vary accordingly. The level of detail possible in this element is significant. The task of the initial observation periods, records reviews, and interviews was to establish general categories of patients based on triage type, urgency, and age. Previous studies have

segregated patients into complaint types (Burstein and Fleisher 1991), acuity (Wilbert 1984) (Castro 1993), body system (Schulmerich 1986), and whether the complaint is the result of trauma or illness (Bursch et al 1993) (Wilbert 1984). The Department of Defense triage system for urgency will be used for this study. The classifications used on the standard record of care and treatment (SF-558) are emergent, urgent, and non-urgent. Patient age has been shown to be a factor in previous studies (Wilbert 1984), and is of importance at Martin Army Community Hospital because of the existence of the after-hours Pediatric Clinic. This clinic was included as an element in the model because of its potential impact on patient flow. The probability and distribution curve of each classification and process was then analyzed and built into the model. The other major outside influence on the ED is the existence of an adjunct acute minor illness clinic, called the FastTrack clinic. It serves as a referral center for patients initially triaged in the ED. It is open for several hours each weekday evening and up to ten hours on weekend days.

Building the Model

After initially collecting the data to determine valid process flow diagrams, IA times, probabilities of occurrence, and duration times, the major task became the actual programming of the model and interface. Computer simulation, once reserved for highly skilled programming specialists and expensive mainframe computers, is now a reasonably achievable tool for researchers and managers with minimal programming experience and a personal computer. The software package used for this model, GPSS/H[®], is very straightforward and maintains sufficient flexibility to perform well in

a variety of environments. The Student Version of GPSS/H[®] was used in building the model. This version has definite limitations and their impact on the study will be discussed in more detail in the results section.

The objective of the model is to provide the manager of the Emergency Department with a tool that can continue beyond this study to evaluate alternatives in resource allocation. The challenge was to provide a model that can be used by non-programmers. This was achieved through a front-end program, Lotus 123[®] for Windows, providing the user with multiple choices including staffing, beds, probabilities, and patient behavior. This level of flexibility will allow future studies on a very narrow focus to alter the parameters established in order to maintain an accurate representation of the actual environment. The model and interface are discussed in greater detail in Appendix B.

Validity and Reliability

Provisions for the validity and reliability of this study were built into the plan in order to develop an accurate and usable tool. Several measures of validity have been discussed in the preceding sections, particularly verification of previous studies and establishing accurate statistical parameters for each process in order to build the model. Further verification of validity were performed by comparing the model output with information gathered through observation. Figures 6 and 7 demonstrate the number of arrivals for each day during a one year period. These figures also reflect the actual number of patients spending more than three hours in the ED, and those patients waiting more than one hour to be seen. Simulating the existing system

Emergency Room Visits

Compared with Patients > 3 Hours

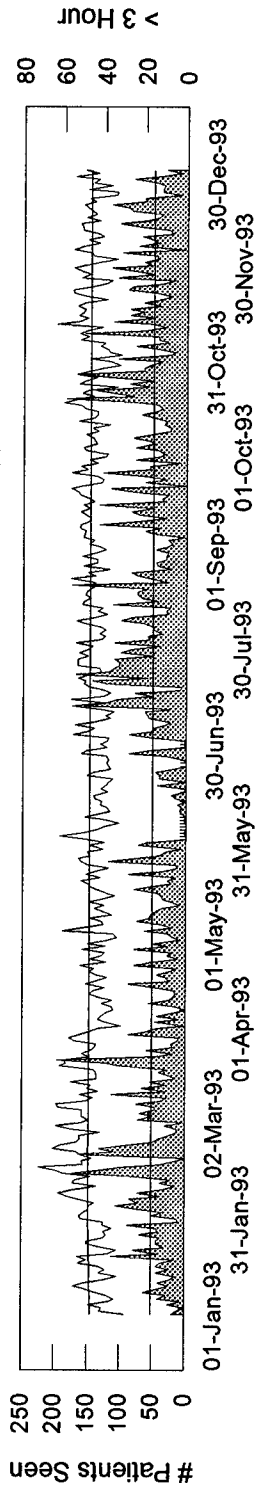

Figure 6

Emergency Room Visits

Compared with Patients > 1 Hour

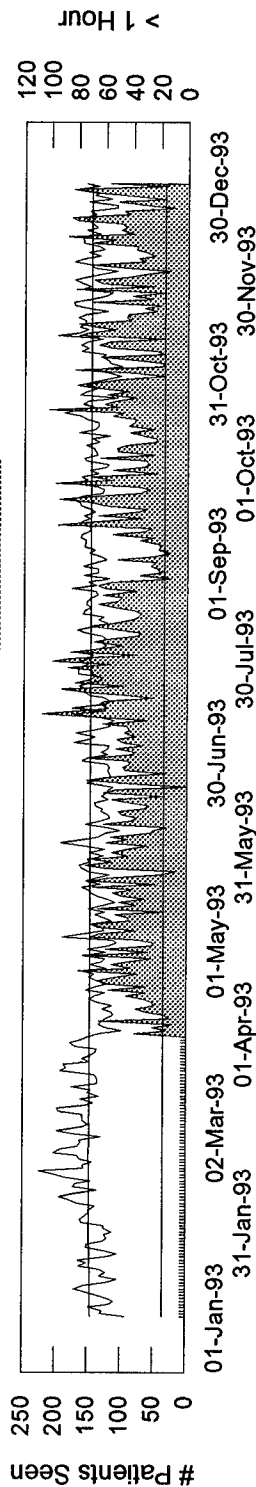

Figure 7

accurately is a prerequisite to accurately simulating proposed changes in the system (Schriber 1991). This is the measurement of how closely the model represents the real environment. The outputs generated from the model include statistical parameters of patient waits and duration of process times, as well as numbers of patients in the system, and each process of the system.

The reliability of the study is a measurement of the amount of error in the results. Polit and Hungler (1983) describe it as "the degree of consistency or dependability with which an instrument measures the attribute it is designed to measure." With the use of computer simulation, the model will reliably perform given that the program is accurately designed and used. The use of a random number generator in each of the processes will produce pseudo-random chances of occurrence. The chances of each event is dependant upon the probabilities entered into the model.

The term "pseudo-random" is used because of the peculiar nature of computer random number generators. With each start-up of the computer and program, the same formula will be used to generate a random number stream. Thus, each run of the model will produce identical results given no other changes in the parameters. However, if the simulation is then replicated many times within each run, the results will properly reflect the random probabilities and distributions programmed into the model. As the number of repetitions increase, the reliability is more accurately measured. The model built for this project provides for a run of 14 weeks, (approximately 14,000 patients) in order to increase the reliability of the results.

Another reliability measurement of this study, and the resultant model, is the consistency of data collected for the purpose of parameter validation. Data gathered on the frequency of occurrence and length of each process must be consistently collected and based on standard times. This was enhanced by clear, concise instruction to the staff on the use of the tool.

Data was collected to establish the interarrival times of patients using information in the AQCESS computer system. This information is entered into AQCESS by the registration clerk at the point of the patient's arrival. The reliability of this data was analyzed on two aspects. The first was whether the times were accurately entered. The second concern was whether all of the patients seen in the ED were entered into the computer.

The random days chosen for establishing IA times throughout the calendar year were generated by a computer program and reflect 25% of each month. Duplicate days generated by the program were altered by adding a random number of days to the second or third occurrence. These dates were then screened according to day of the week and verified that the dates chosen were a normal distribution of possible dates. No statistical difference was determined in the number of each days of the week (Mean day of month=14.29, S.D.=2.14, $p<.01$).

Ethical Considerations

Confidentiality and right to privacy are significant considerations in performing research in the health care setting. This study provided for patient and staff confidentiality by recording data based on patient log numbers and job classification of

staff member. Data collected from the AQCESS computer evaluated by log numbers alone, and patient names and social security numbers were not accessed. The ED staff were informed of the data collection techniques, confidentiality safeguards, purpose of the study, and expectant use of the data collected prior to initiating the study. Since Privacy Act information (patient name or other individual unique data) were not collected, permission was not sought from patients.

CHAPTER THREE

RESULTS

The initial efforts for building the model were in determining patient interarrival periods. The critical data was obtained from the AQCESS computer which provided ED logs for 96 randomly selected days between November 1, 1992 and October 31, 1993. These logs were screened against the hand written logs for completeness and accuracy. Completeness was rated for each day and ranged from 25.4% to 97.5%. Generally, it was found that losses in completeness were in large blocks of time, such as midnight to 7:00 am. These blocks of time were attributed to non-availability of the computer for ED use (back-ups, maintenance, etc). These

Table I Descriptive statistics on patient interarrival times using 6-hour blocks

	Midnight to 6 am	6 am to 12 pm	12 pm to 6 pm	6 pm to Midnight
Mean IA Time (weekday)	33.06	12.32	8.34	8.96
Standard Deviation	45.33	44.51	25.44	36.77
n	200	1192	1481	1359
Mean IA Time (weekend)	39.29	18.40	8.18	8.72
Standard Deviation	54.02	56.11	11.43	19.67
n	417	1865	3022	2673

(times in minutes)

blocks were removed from consideration for statistical analysis. Accuracy was determined by randomly selecting five entries from each day and comparing the time of arrival between the two sources. Measurements for accuracy averaged 94.3%, with a range of 40% to 100%.

Table II Correlation of time of day to IA time

	Time	r	p
Weekday	MN-6am	.1400	*
	06-Noon	.0746	*
	Noon-6pm	-.0591	*
	6pm-MN	-.0468	*
Weekend	MN-6am	.0752	*
	06-Noon	.0033	.719
	Noon-6pm	-.0282	*
	6pm-MN	-.0289	*

The AQCESS data was converted into a spreadsheet for further analysis. Interarrival time periods were calculated from the cumulative data and frequencies, means, and standard deviations calculated for six-hour blocks, beginning at midnight, for both weekday and weekend/holiday visits (Table I). The six-hour blocks were tested for correlation with IA times, and the results are shown in Table II.

Two modes of analysis were used to determine if the IA periods were marked with a seasonal influence. The first was a correlation test of season of the year to IA times. A significant correlation was not detected, as shown in Table III. The second

evaluation performed was to compare 478 days of ER visits to expected curves using forecasting techniques. The actual data was more closely approximated by a linear curve (MSD=526.4), than the Winter's Model (seasonal) curve (MSD=599.1), indicating no significant seasonal character.

Table III Correlation of IA time to season.

Season	r	p
Spring	-.0056	.533
Summer	-.0003	.976
Fall	.0020	.828
Winter	.0049	.587

Cumulative frequency distributions were measured, using SPSS/Windows®, for curve estimation. The six-hour blocks did not statistically approximate exponential curves (Figures 8 and 9), the curve most likely to represent patient arrivals. The data was then broken down into one hour blocks of time. These interarrival periods statistically represent exponential curves (Table IV).

It was determined by the ED management staff that a full study of all the identified processes in the model would overwhelm the staff and could adversely affect patient care. We decided to perform two short time studies, one on the registration process and the other on the triage/vital signs process. The former was evaluated by observations and recording of the start and stop times by the observer. With 53 observations, the mean time was 3.2 minutes with a standard deviation of 2.8 minutes. The triage process was evaluated through the use of a log sheet, collected each shift by the researcher. The log sheet was very simple and required only a summary explanation. The nursing staff entered the time that they called the patient in for

Cummulative Distribution Function

Weekday

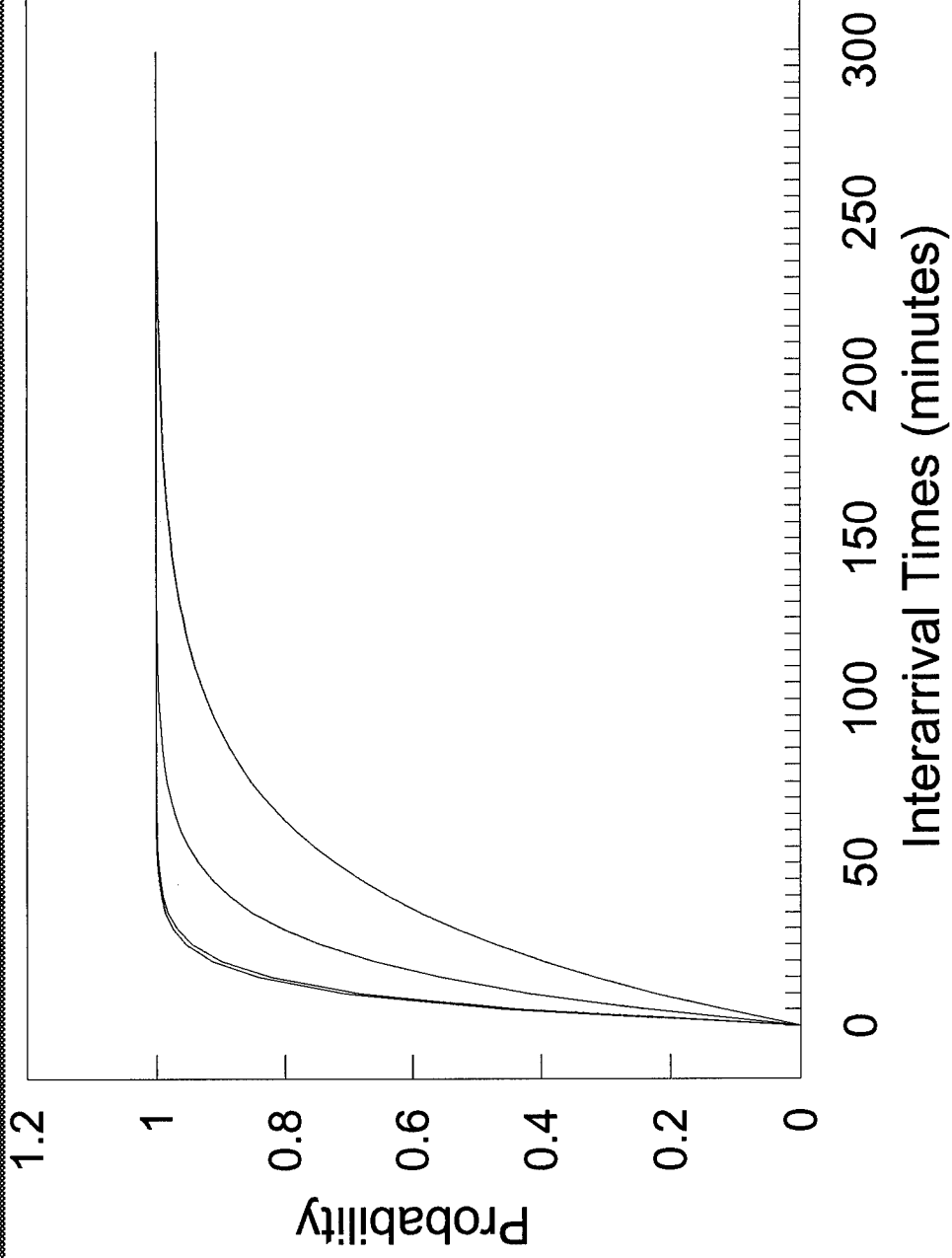

— 0000 - 0600
— 0600 - 1200
— 1200 - 1800
— 1800 - 2400

Cummulative Distribution Function

Weekend & Holiday

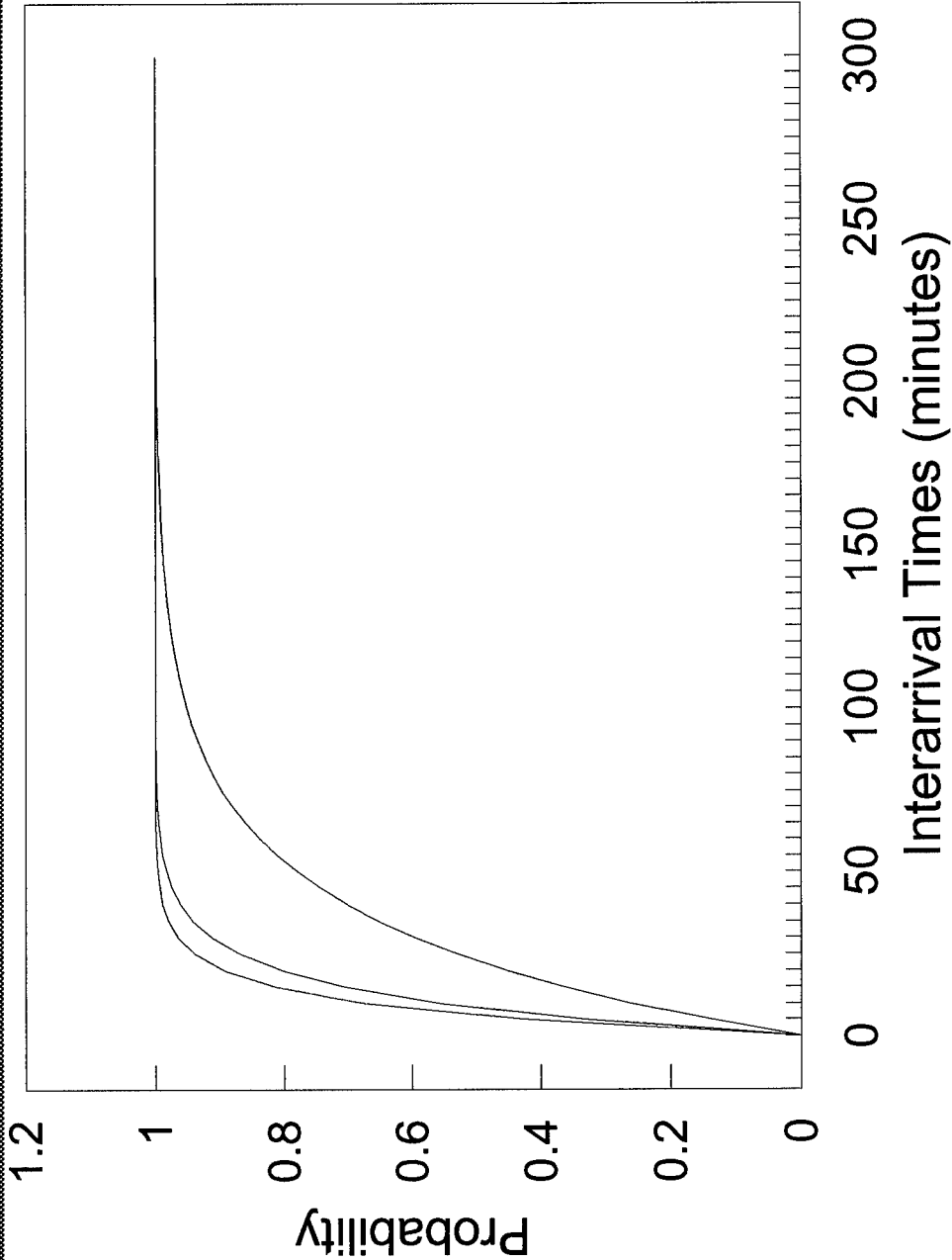

triage, and in the next column they entered the time that the patient left the triage area. For simplicity and protection of privacy, patient identifying information

Patient Interarrival Time Frequency Distribution						
Compared with Exponential Curve						
Hour	Weekday	n	p<.001	Weekend	n	p<.001
1	22.65	121	yes	15.53	43	yes
2	32.12	68	yes	25.81	21	yes
3	34.88	78	yes	25.73	22	yes
4	26.68	85	yes	32.67	15	yes
5	36.62	47	yes	19.8	15	yes
6	33.02	58	yes	37.74	19	yes
7	30.48	96	yes	28.09	22	yes
8	23.14	146	yes	18.53	45	yes
9	11.27	422	yes	8.22	125	yes
10	9.08	526	yes	6.32	166	yes
11	8.75	552	yes	5.70	177	yes
12	8.77	529	yes	5.76	189	yes
13	9.21	476	yes	6.20	157	yes
14	9.83	489	yes	6.62	154	yes
15	8.62	551	yes	6.09	165	yes
16	7.83	590	yes	7.69	132	yes
17	6.54	727	yes	7.78	155	yes
18	6.72	708	yes	6.33	181	yes
19	6.33	665	yes	5.56	201	yes
20	5.94	655	yes	7.22	166	yes
21	6.45	609	yes	6.65	157	yes
22	8.10	483	yes	7.42	154	yes
23	9.20	462	yes	9.92	98	yes
24	14.54	299	yes	12.24	87	yes

Table IV - Fitting the IA times with an exponential curve

was not collected, only the times in and out of the triage area. Through the four days of study, 128 valid time periods were collected. Analysis of these showed a mean of 4.13 minutes, with a standard deviation of 2.19 minutes, and a range from 1 to 11 minutes. These times were later used in the model to provide the duration of the registration and triage processes.

The ED maintains monthly reports on services provided, types of patients seen, and daily tallies of patient acuity, transfers out of the hospital, admissions, and deaths. The reports are not consistent, however, in what is computed. They reflect changing management focuses on relevant statistics. Several months of reports counted the number of patients triaged out of the ED to other clinics, while others counted the number admitted, and others focused on deaths or number discharged home. Twelve months of reports were examined and determinations made on the frequency of occurrence of admission, death, transfer, or number of patients that left without being seen by a provider (renege). Patient acuity was routinely recorded in these reports. The number of patient visits to the ED was divided into the triage categories of emergent, urgent, and non-urgent. These monthly figures were summed and descriptive statistics computed. The proportion of non-urgent patients was found to be 84%, while 14% of the patients are classified as urgent, and only 1% categorized as emergent.

The Chief of Emergency Services and the Clinical Head Nurse were interviewed to determine the ED's staffing patterns. The patterns of physician and nursing coverage of the ED are shown in Figures 10 and 11. The minimal number of

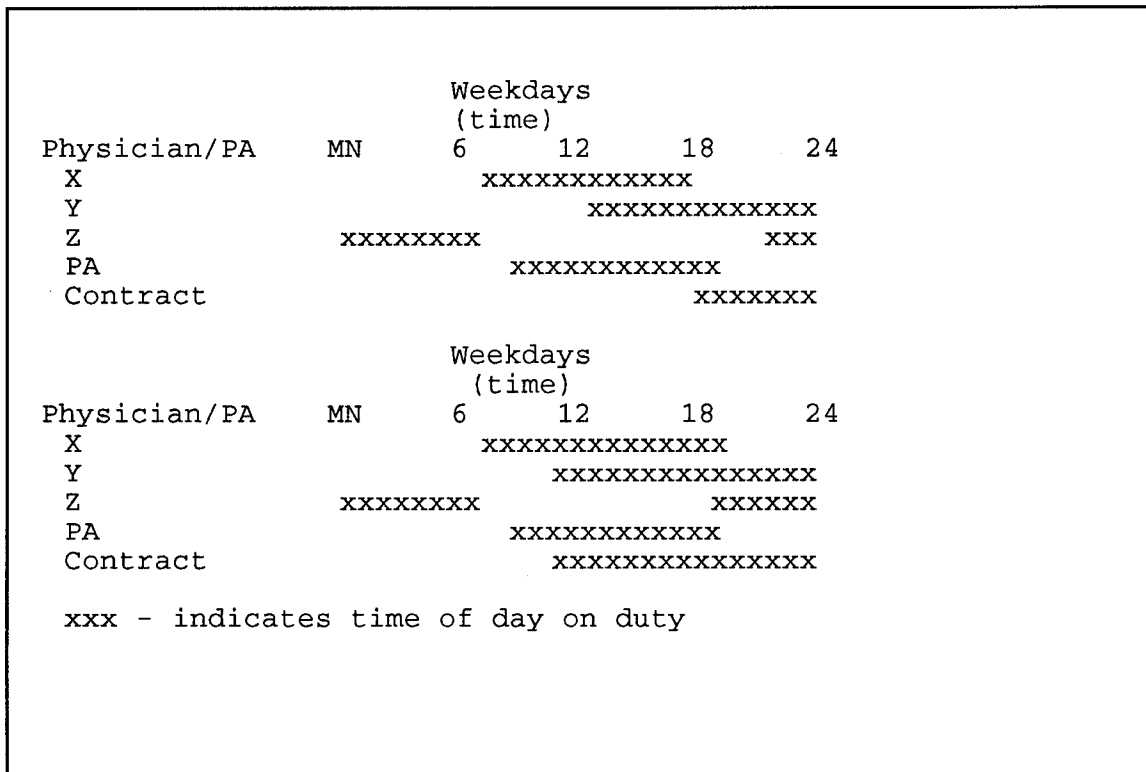

Figure 10 Physician and Physician Assistant Staffing Patterns

physicians is one (midnight to 7:00 am), while the minimal number of nursing staff is four (11:00 pm to 7:00 am). From 11:00 pm to 7:00 am, the fourth nursing staff member functions as a registration clerk. The registration desk is staffed by one clerk from 8:00 am to 4:00 pm, and two clerks from 4:00 pm to midnight.

The construction of the model began with no significant problems. The software used, GPSS/H[®], lends itself well to the complexities of the Emergency Department. Difficulties arose when the final stages of model building were at hand. The constraints of the Student Version of the software prevented some of the processes from being included in the final model (written into the code, but not activated), and

Nursing Staff	Weekdays and Weekends (time)			
	MN	6	12	18 24
RN	xxxxxxxxxx			xx
RN		xxxxxxxxxx		
RN			xxxxxxxxxx	
LPN	xxxxxxxxxx			xx
LPN		xxxxxxxxxx		
LPN			xxxxxxxxxx	
91B			xxxxxxxxxxxxxx	
91B			xxxxxxxxxxxxxx	
91B			xxxxxxxxxxxxxx	
91B	xxxxxxxxxx			xxxx
91B(clerk)	xxxxxxxxxx			xx
Clerk		xxxxxxxxxx		
Clerk			xxxxxxxxxx	
Clerk			xxxxxxxxxx	

xxx - indicates time on duty

Figure 11 Nursing personnel staffing patterns

also prevented the accumulation of some of the variables for outcome analysis. These limitations are discussed further in Appendix B. The final product, though limited to those processes that occur more than 99% of the time, provides a very accurate depiction of the patient flow through the ED.

Throughout the building of the model, tests were run to ensure that the model projected a true image of the real system. Tests were performed on the formulae used to arrive patients at the ED. The arrival rates were compared between the model and a sample of 10% of the actual data using a two-sample T-test. No time period showed a significant difference between the arrivals in the model and the real data ($p > 0.1$). Final testing of the model consisted of running the model for 15 weeks of simulation, while accumulating statistics on patient waits, arrivals; staff utilization factors and

length of stay in the ED. The results showed an average arrival of 142 patients per day, compared with an actual average daily rate of 145 patients. The difference between these two proportions is not statistically significant ($p=.4012$).

Approximations of length of processes were made after consulting with the ED staff. Statistical analysis of these results is not relevant, since many of the factors involved were based on assumptions and perceptions of length of time and duration. These processes will be further analyzed by the end user of the program to refine and improve upon the accuracy of the model.

CHAPTER FOUR

DISCUSSION

These results show that it is possible to gather sufficient information on the processes involved in providing emergency care to build a valid computer simulation. This study has shown that much data is regularly accumulated that describes the operations and flow of the ED, once it is gathered together.

The data available on patient arrival came from the AQCESS computer. The use of automation in recording patient flow greatly enhances the manager's ability to monitor and effect changes when and where necessary. The ability to download this data and use it on other computers or combine it with other data makes this type of information source even more powerful. Data derived from this source type is useful for establishing trends, since its format and method of entry does not tend to change over long periods of time.

The accumulation of information in manual summary reports was shown to be of value in describing other aspects of the patient flow process. Statistics found within these reports on the acuity of the patients, their disposition status, and number of hours waiting for service provided the means to build into the model valid probabilities of occurrence. The difficulty found in relying on these types of records is that they are not easily validated, and the types of information gathered is largely dependent upon the short-term interests of the manager. Determining long-term trends and

accumulating larger quantities of data is difficult when the report format and content change every three to four months.

The fluctuations in patient arrival patterns were found to be very similar to those anticipated. The hourly and daily (weekday v. weekend) patterns were established as having definite distinction. The patterns anticipated for seasonal changes were not validated. The data available was limited to only 438 days. This limit did not provide for comparison of more than one season. Visual evaluation of the entire 438 day period appears to show increased patient visits during the late winter months (February and March), but was not statistically validated. Further evaluation of this relationship is warranted, and should be built into the model if later substantiated.

Patient arrival rates were found to be exponential. Arrival rates tend to be exponential in nature for most other services. Breaking the day into other than one hour blocks weakens the simulator's ability to capture the nature of patient flow. The initial attempts at using six-hour blocks met with the inability to establish the proper IA distribution curve necessary for simulation.

Short, simple measurements of the many processes involved in the ED are possible, and perhaps more desirable than longer, more complete studies. The overall effect of measuring one or two aspects of a complicated system are minimal, whereas, large scale studies of all aspects of the system slow it down or change its nature. The two short studies done for this project yielded good information about the processes

and demonstrated to the ED staff that research does not necessarily involve pain and extra work.

The wide variety of staffing patterns in place in the MACH ED were surprising. The managers of the ED have attempted, over time, to closely match the number of providers available to the patient flow. This type of innovative scheduling should optimize the staffing, provided sufficient human resources of the right type and quantity are available. The model must be able to account for the existing patterns and lend itself to further innovation through time. This model allows for the user to input staff schedules in a variety of means.

CONCLUSIONS

Much of the literature cited in this paper dwells on patient satisfaction, and how the duration of waits impacts on their level of satisfaction. A project such as this can help the Emergency Department management team evaluate how different processes influence the patient wait, thereby, influencing patient satisfaction. The results presented provide a strong argument for the continued testing and use of this model and of building the database required to more accurately represent the existing conditions. The significance of these results are that, though they do not paint the precise picture of the ED, they provide the basis on which to continue to work. The interface and model program written are user friendly and a potentially valuable tool in Martin Army Community Hospital's continued efforts toward improving quality and access, while minimizing costs.

REFERENCES

- Abramowitz, Susan, Sharon A. Joy, and Roger W. Yurt. 1989. Emergency room visit time: Changes over a 16-year period. New York State Journal of Medicine. 89(8):446-9.
- Ahituv, Niv and Oded Berman. 1987. Devising a cooperation policy for emergency networks. Journal of Operational Research Society. 38(11):1015-1029.
- Baligh, Helmy H., and Danny J. Laughhunn. 1969. An economic and linear model of the hospital. Health Services Research. 4(4):293-303.
- Bindman, Andrew B., Kevin Grumbach, Dennis Keane, Loren Rauch, and John M. Luce. 1991. Consequences of queuing for care at a public hospital Emergency Department. Journal of the American Medical Association. 266(8):1091-1096).
- Bloom, Bernard S., and A. Mark Fendrick. 1987. Waiting for care: queuing and resource allocation. Medical Care. 25(2):131-9.
- Booth, A.J., C.J. Harrison, G.J. Gardener, and A.J. Gray. 1992. Waiting times and patient satisfaction in the accident and Emergency Department. Archives of Emergency Medicine. 9(2):162-8.
- Bursch, Brenda, Joseph Beezy, and Ruth Shaw. 1993. Emergency Department satisfaction: What matters Most? Annals of Emergency Medicine. 22(3):586-90.
- Burstein, Jonathan, and Gary R. Fleisher. 1991. Complaints and compliments in the pediatric Emergency Department. Pediatric Emergency Care. 7(3):138-40.
- Castro, Rolando, Jr. 1993. An analysis of patient waiting time in the emergency room at Martin Army Community Hospital, Fort Benning, Georgia. Unpublished. Baylor University.
- Coburn, Mary S. 1988. One hospital's experience with guidelines for improved collaboration between emergency medical technicians, nurses, and physicians. Journal of Emergency Nursing. 14(1):19-22.
- Cross, Gerald, Kenneth Franklin, and Kevin Lokkesmoe. 1993. ER: Access Time. Briefing for the Commander, Martin Army Community Hospital. November 5, 1993.
- Dickinson, Garth. 1988. Emergency Department design and patient flow. Annals of Emergency Medicine. 17(6):664.

- Gray, A.J., C.J. Harrison, G.J. Gardener, and A.J. Gray. 1992. Waiting times and patient satisfaction in the accident and Emergency Department. Archives of Emergency Medicine. 9:162-8.
- Hu, Sheng-Chuan. 1993. Computerized monitoring of Emergency Department patient flow. American Journal of Emergency Medicine. 11(1):8-11.
- Joint Commission on Accreditation of Healthcare Organizations. 1993. 1994 Accreditation Manual for Hospitals. Volume I, Standards. 105.
- Lusk, Edward J. 1980. A suggested process for selecting a forecasting model. Hospital & Health Services Administration. Special I:23-37.
- Martin Army Community Hospital. 1993. Review and Analysis. October, 1993. PAL.
- Pachter, Lee M., Stephen Ludwig, and Ashley Groves. 1991. Night people: Utilization of a pediatric Emergency Department during the late night. Pediatric Emergency Care. 7(1):12-14.
- Polit, Denise F. and Bernadette P. Hungler. 1983. Nursing Research: Principles and Methods. (J.B. Lippincott Company: Philadelphia).
- Saunders, Charles E. 1987. Time study of patient movement through the Emergency Department: sources of delay in relation to patient activity. Annals of Emergency Medicine. 16(11):1244-8.
- Saunders, Charles E., Paul K. Makens, and Larry J. Leblanc. 1989. Modeling Emergency Department operations using advanced computer simulation systems. Annals of Emergency Medicine. 18(2):134-40.
- Schriber, Thomas J. 1991. An Introduction to Simulation Using GPSS/H. (John Wiley & Sons:New York).
- Schulmerich, Susan C. 1986. Converting patient classification data into staffing requirements. Journal of Emergency Nursing. 12(5):286-290.
- Smeltzer, Carolyn H. 1986. Analyzing patient time in the Emergency Department. Quality Review Bulletin. 12(11):380-2.
- Swiderski, Frederick A. 1990. Efficient use of emergency room resources at Bayne-Jones Hospital. Unpublished. Baylor University.
- Thorpe, Darrell P. 1972. A "time study" approach to the evaluation of emergency room activities. The Journal of the Maine Medical Association. 63:197-199.

- Valenzuela, Terence D., Jeffrey Goldberg, Kevin T. Keeley, and Elizabeth A. Criss. 1990. Computer modeling of emergency medical system performance. Annals of Emergency Medicine. 19(8):898-901.
- Walrath, Jo Marie. 1983. Computer-assisted management in an Emergency Department. Journal of Emergency Nursing. 9(4):235-6.
- Wilbert, Catherine C. 1984. Timeliness of care in the Emergency Department. Quality Review Bulletin. 10(4):99-108.

APPENDIX A
GLOSSARY OF TERMS

ASCII	Standard computer file format, readable by nearly any type of computer
AMEDD	The U.S. Army Medical Department; the overseeing major command element for all U.S. Army medical services and personnel. It is currently used to describe the elements of The Office of the Surgeon General which do not coincide with Health Services Command.
AQCESS	Automated Quality of Care Evaluation Support System, a computer system that supports the patient administration functions of military treatment facilities. Used in the Emergency Department to log patients in and create a treatment form (SF-558).
DT	process duration times; the time it takes to perform an activity or function
ED	Emergency Department
Emergent	A patient with a life or limb critical injury or illness, typified by a patient with serious trauma, or in cardiac arrest.
HSC	Health Services Command; based in San Antonio, Texas, is in transition to being the Medical Command (effective October 1994). Provides policy and direction for provision of medical services at all military treatment facilities, worldwide.
IA	Interarrival times; the time measured between one patient arriving and the subsequent patient arriving.
JCAHO	Joint Commission on Accreditation of Healthcare Organizations

Level II ED	An Emergency Department offering "emergency care 24-hours a day, with at least one physician experienced in emergency care on duty in the emergency care area, and with specialty consultation available within approximately 30 minutes by members of the medical staff or by senior-level residents." (JCAHO definition)
MACH	Martin Army Community Hospital, Fort Benning, Georgia
Non-urgent	Patients that are primarily ill or injured in such a fashion that delays in treatment will not result in a poorer outcome or loss of function.
PA	Physician Assistant; a professional provider, who, while working under the supervision of a physician, provides primary and secondary medical evaluation and treatment. Is considered comparable to a physician in only the most general sense for the purposes of staffing in the ED.
PFD	Process flow diagram; a pictograph showing how objects or people move through a system.
PR	Probabilities of occurrence; the probability that event A will occur, such as the percentage of patients that are admitted to the hospital.
Reneging	Leaving the emergency room without being seen by a physician
SF-558	Standard record of care and treatment in military treatment facility emergency departments.
Urgent	A patient that needs immediate medical intervention to keep their condition from worsening and becoming emergent.

APPENDIX B

DISCUSSION OF THE MODEL AND INTERFACE

The Interface

The technical discussion of the program provided below assumes some familiarity with simulation programming, particularly that of GPSS/H[®]. If you find that the discussion, and subject matter is of interest, I recommend reading "An Introduction to Simulation, Using GPSS/H" by Thomas J. Schriber.

To provide a naive user interface to the simulation software required a means of seamlessly getting both in and out of the simulation, while monitoring memory usage and having the ability to read and write ASCII files. The secondary consideration was the ability to create an interface that would provide graphical representation of the output of the model and also provide a colorful, pleasing environment in which to work.

The memory manager in the Microsoft Windows[®] shell provided the means of moving in and out of the interface and the simulation without hampering the effectiveness of either. Lotus 123 for Windows[®] met the other needs of the interface. It provides a plethora of graphical tools, as well as containing a sophisticated programming language in which to build a naive user interface. Through the use of special menus, user buttons, locked data fields, and help screens, the interface was made very friendly. Lotus[®] is able to write ranges of information to separate ASCII

files for use by other programs. It is also capable of reading the same types of files into specified ranges within a worksheet. The graphing capabilities present colorful, easy to read displays of the output data.

The interface was designed to provide screen by screen data review and entry by the end user. It provides the capability to review, enter, or change any of the 90 variables in the model. There is also a provision for designing complex staffing schedules that interact with the simulation very easily. Several of the screens are depicted in Appendix C. This program, as with all software, will undergo revision and refinement as it undergoes further testing and usage by the end users. Some of the screens presented in this paper may differ from those seen on the current version of software accompanying it.

The Model

The Student Version of GPSS/H[®] is an economical purchase, yet provides a significant amount of power for the simulator. The constraints placed on this Version 2.01 of this software include a limitation of 125 model blocks and 125 control blocks. Comments, blank lines, and continued lines are not counted in this sum, however, they seem to impact upon the total amount of memory available when running the program. Most of the program code is written in a straight-forward manner and easily understood by the novice programmer. Most of the processes in the ED can be represented by these simplex statements and routines.

Several of the processes required more complicated programming techniques and bear more explanation and discussion. A copy of the GPSS/H[®] code is included in Appendix E. References to that code will be by line number. The issues that presented a more complex challenge involved staffing different types of personnel with different shifts; providing after hours clinic referrals, also on different schedules; drawing laboratory specimens and linking the results with the correct patient; and treating one category of patients (Emergent), in a different mode, using a specific bed. These variances provided a programming challenge that forced several confrontations with the limitations of the Student Version.

The staffing problem was resolved through the use of two-dimension arrays for each of the three personnel types, physicians/PAs, nursing staff, and registration clerks. GPSS/H[®] provides ampervariables for use in both model and control blocks, however, they are single-dimension and do not provide the answer for this dilemma. GPSS/H[®] has the means of storing memory variables in two dimensional Matrix Savevalues. These Savevalues are accessible only within the program and can't directly read external variables.

Lines 39 through 54 take the external values for the staff schedules and store them into the Matrix Savevalues ZZ1, ZZ2, Y1, Y2, Z1, and Z2, each defined by an array of 24 by 12 variables. The external source for these values are six ASCII files written in a 24 line by 12 column matrix (Figure 12). Each cell of the matrix contains the number of personnel arriving to work at a specific hour (row) for a set number of hours (column). The control statements in lines 308 through 377 then check each of

these matrixes to determine how many personnel are arriving for duty and how many are departing from duty. The BSTORAGE statements in lines 85, 97, and 116, then perform checks to determine if the number of each type of personnel are properly represented in the STORAGE (or capacity of each personnel type).

If the number of oncoming personnel is less than the previous quantity (more staff leaving than coming), then the BSTORAGE decrements the STORAGE one at a time, when each patient releases a staff member. In the real situation, the staff does not just stop treating a patient when their duty tour is complete, especially if there is not a 1:1 staff relief. They will not, however, assume a new task when that one is complete, as is represented in the model. One limitation of this approach is that it limits staffing changes to the hour, and cannot pick up those changes that might occur on the half-hour. The timing loop of the program (line 281) could be modified to reflect 48 iterations per day, however, the impact on processing speed would be significant.

The challenge of providing after-hours clinics, the schedules of which could be "played with" by the end user, was met in a similar fashion as the staff scheduling. The OTHCLIN (line 255, 287, & 335), is a simplified version of a fuller model, in which there would be three or four clinics available for input. The interface allows data entry for a Pediatrics clinic, the FastTrack clinic, and an "other" clinic, that receive patients from the ED after triage. This model rolls all three up into one clinic which represents the sum of their individual capacities. The limitations of the Student Version precluded entering the lines of code necessary to maintain the individual

0	0	0	0	0	0	0	0	0	0	0	0
0	0	0	0	0	0	0	0	0	0	0	0
0	0	0	0	0	0	0	0	0	0	0	0
0	0	0	0	0	0	0	0	0	0	0	3
0	0	0	0	0	0	0	0	0	0	0	0
0	0	0	0	0	0	0	0	0	0	0	0
0	0	0	0	0	0	0	2	0	0	0	0
0	0	0	0	0	0	0	0	0	0	0	0
0	0	0	0	0	0	0	0	0	0	0	0
0	0	0	0	0	0	0	0	0	0	0	0
0	0	0	0	0	0	0	0	0	0	0	0
0	0	0	0	0	0	0	1	0	0	0	0
0	0	0	0	0	0	0	0	0	0	0	0
0	0	0	0	0	0	0	0	0	0	0	0
0	0	0	0	0	0	0	3	0	0	0	0
0	0	0	0	0	0	0	0	0	0	0	1
0	0	0	0	0	0	0	0	0	0	0	0
0	0	0	0	0	0	0	0	0	0	0	0
0	0	0	0	0	0	0	0	0	0	0	0
0	0	0	0	0	0	0	0	0	0	0	0
0	0	0	0	0	0	0	0	0	0	0	0
0	0	0	0	0	0	0	0	0	0	0	0
0	0	0	0	0	0	0	2	0	0	0	0
0	0	0	0	0	0	0	0	0	0	0	0

Figure 12 Sample data file for staffing matrix (filename=NURSE1.)

storage of all three clinics. Recoding the program on a non-limited version would be simple and straightforward.

The clinic resources were not built into complex matrixes. Since the clinics open and shut once each day, a simpler approach of using ampervariables for the time the clinic opens and closes, and the capacity (patients per hour) of each when open, sufficed for proper representation. The triage personnel refer patients to these clinics only after determining how many are in the clinic queue. The rough figure used for each of the clinics is approximately five patients each hour.

The laboratory specimen problem offered the most interesting challenge. The initial model sent the patients to the laboratory for a predetermined distribution of time. This prevented the patient from receiving any other treatment or referrals. This did not represent the real situation, in which only the patient's specimens are sent to the lab, while the patient, remains in the ED for further evaluation or treatment. Through the use of the SPLIT and ASSEMBLE blocks, a clone of the patient, representing the drawn specimen was sent to the laboratory for the predetermined distribution of time and then sent back to the treatment area to be rejoined with the patient prior to the secondary evaluation by the physician (lines 119 and 173).

The lab specimen SPLIT/ASSEMBLE system works very well for thousands of patients in the simulation, however, the user will see warnings on the initial screens that patients are leaving queues that they don't belong to, and patients being terminated that belong to one or more queues. These are traced back to two patients that don't, for some unknown reason, get back together with their specimens. Each of the entities

then continue through the system, generating warnings as they go. Changes made to the random number generator simply move these two patients to another point in the run of the model--two patients never seem to get it together. (When discussing this problem with the clinical users, they laugh and tell me that if they only had two patients that didn't get their lab results, they would consider it a perfect process!) These two patients do not appear to have any adverse affect on the statistics gathered.

Two separate type of beds exist in the community hospital ED, regular treatment beds, and "crash" beds. Crash beds are usually in a physically larger room, surrounded by a vast array of highly technical equipment. These beds provide the ED personnel the space and equipment necessary to take care of the seriously ill or injured patient. They are not usually used by other than truly emergent patients. The program allows for emergent patients to occupy this resource (default of one bed) and checks patients leaving the ED for a half-word parameter that determines which type of bed to clear and make available for use (line 238).

Memory

The current program reallocates 27,450 blocks of memory for the operation of the model. Because of the constraints of the Student Version, this puts a cap of about 70 patients that can be in the ED at one time. This is not an unrealistic cap for the MACH ED, however, to apply this model to a larger ED would meet with failure. At the level of detail presently included in this model, the Student Version can not adequately represent the volume that busier EDs would present. When running this software, variations made in staffing and other parameters can make the number of

patients in the system exceed the limits of memory. The system then stops and returns to the Lotus® interface. The interface has a routine built in to determine if all 14 weeks were simulated, and if not, tells the user when the crash occurred. The test users found this more helpful than trying to open the standard GPSS/H® file to read the clocks and read the ERROR messages.

The other aspect of memory problems came in storing output information. The limitations of the program prevented many useful variables from being collected for presentation in the spreadsheet interface. A non-limited version of GPSS/H® would allow much more reporting and evaluation, a very worthwhile product.

APPENDIX C
SCREENS OF THE SPREADSHEET INTERFACE

Martin Army Community Hospital

Emergency Room Simulation

Author: Major Timothy Reese, AN

This program is designed to provide the Emergency Room with a tool that dynamically evaluates the effect of patient flow, staffing, and other factors on ER operations.

Use the mouse to click on a button or press the ALT key to select from the menu options above. I recommend that first time users go through the introduction prior to running the model.

05/19/94

ERTEST.WK4

Introduction to Simulation

Computer simulation is the process of applying real processes to the theoretical environment, using mathematical formulae to represent the processes. Computers allow us to build, test, and run these models with relative ease. This simulation program is built around the GPSS/H programming language and attempts to create an accurate representation of the Emergency Room at Martin Army Community Hospital, at Fort Benning, Georgia.

The goal of this simulation is to provide the Emergency Room Management Staff with the capability of changing various resources or other elements of the Emergency Room model and see how these changes will affect patient flow and resource allocation. Outcome measures on patient wait-time, efficiency of human resources, and bed and space uses are collected during the modeling process and reported back to the manager.

The user must continue to bear in mind that no mathematical formula or computer representation can perfectly represent the intricacies of human behavior. Special causes of variance in arrival rates, treatment times, and flow patterns will affect how well the model reflects reality.

With that caveat in mind, this model attempts to account for many of the common causes of variance through a number of measures and functions. The most important aspect of a model is determination of the flow of objects (patients, specimens, staff members) through the various processes. This model is based on the flow patterns described in the users guide, page ##.

The DEFAULTS option on the menu will lead the user through the model, showing how each element is represented and the duration, frequency, or probability of each is calculated. The user has the option of changing any of these mathematical representations of human behavior, and then run the model to determine the effects.

The next step in the model is to RUN the simulation. The screen will change several times as the program takes the information out to the GPSS/H programming language and simulates thirteen weeks (1/4 of the year) of patient arrivals to the simulated ER.

The program will then tabulate the outcome measures on waiting times, volume, and resource allocation for the user's evaluation. The user will compare these outcomes with previously determined benchmark measurements and be able to assess the effect of the changes or assumptions on the effectiveness of the model.

These results are referred to in the REPORT area of the program. The user may elect to keep the results as a new benchmark to compare future reports with, discard them, or print the results out to a printer.

You may change any of the parameters in this model. Caution should be taken in making changes that are likely to dramatically increase the number of patients in the ER at any one time. The software running the simulation dies out if there are more than 80 to 100 patients in the ER at any one time (the staff would start dieing also!).

Referring to the patient flow model in the User's Guide, changes may be made to a number of different types of parameters.

Probabilities: The frequency at which a process occurs. An example is that 29% of the patients treated require Laboratory studies.

Task Duration: Each process requires a mean (average) time for completion, as well as a Standard Deviation. An example is that it takes an average of 4.2 minutes to complete Vital Signs and Triage of patients (STD=2.3 minutes).

Patient Behavior: Arrival rates, % that leave without being seen, etc.

Other Clinics: Clinics to which patients are sent after triage (Peds, Fast Track, etc)

Nurse Staffing Patterns

of Nursing Staff:

12 hour shifts

Shift 1 begins:	6
Shift 2 begins:	18

Weekdays	Weekends
1	1
1	0

8 hour shifts

Shift 1 begins:	7
Shift 2 begins:	15
Shift 3 begins:	23

Weekdays	Weekends
1	2
2	2
1	1

Other Shift

Shift begins:	10
Shift length:	8

Weekdays	Weekends
0	1

Other Shift

Shift begins:	8
Shift length:	12

Weekdays	Weekends
0	0

Other Shift

Shift begins:	12
Shift length:	8

Weekdays	Weekends
1	0

Physician/PA Staffing Patterns:

of Physician/PA Staff:

12 hour shifts

Shift 1 begins:	6
Shift 2 begins:	18

Weekdays	Weekends
1	1
1	1

8 hour shifts

Shift 1 begins:	6
Shift 2 begins:	14
Shift 3 begins:	22

Weekdays	Weekends
1	1
2	2

Other Shift

Shift begins:	10
Shift length:	8

Weekdays	Weekends
1	

Other Shift

Shift begins:	16
Shift length:	8

Weekdays	Weekends

Other Shift

Shift begins:	12
Shift length:	8

Weekdays	Weekends

After Hours Pediatric Clinic

	Weekdays	Weekends
Clinic Opens:		
Clinic Closes:		
Capacity (pts/hr):	5	5

(enter time HH:MM)

Fast Track Clinic

	Weekdays	Weekends
Clinic Opens:		
Clinic Closes:		
Capacity (pts/hr):	5	5

Other Clinic

	Weekdays	Weekends
Clinic Opens:		
Clinic Closes:		
Capacity (pts/hr):	5	5

Patient Behavior

	Change	Default
% of Nonurgent patients:		85%
% of Urgent patients:		14%
% of Emergent patients:		1%
% of patients that LWBS:		3%

*** Enter numbers as decimals (eg. 34% is entered as .34) ***

Output Reports

	Results	Benchmark
Mean total time in the ER:		120.00
Maximum time in ER:		180.00
Maximum contents of ER:	16.00	25.00
Mean number of patients in ER:	14.48	20.00
Maximum time in ER:	210.00	120.00
Mean time waiting for treatment:		45.00

Times are expressed in minutes, unless otherwise

Mean visits (weekdays):		140.00
Mean visits (weekends/holidays):		150.00

% of patients over 3 hours:		12%
% of patients over 1 hour:		8%

% of patients admitted:		5%
% of patients transferred:		3%

Output Reports (continued)

	Results	Benchmark
Mean time waiting for triage:		120.00
Maximum time waiting for triage:		180.00
Mean time waiting for labs/xrays:		45.00
Maximum time waiting for labs/xrays:		60.00
Mean utilization of MDs/PAs:	0.40	85%
Mean utilization of nursing staff:	0.77	8%
Mean utilization of treatment beds:	100%	75%

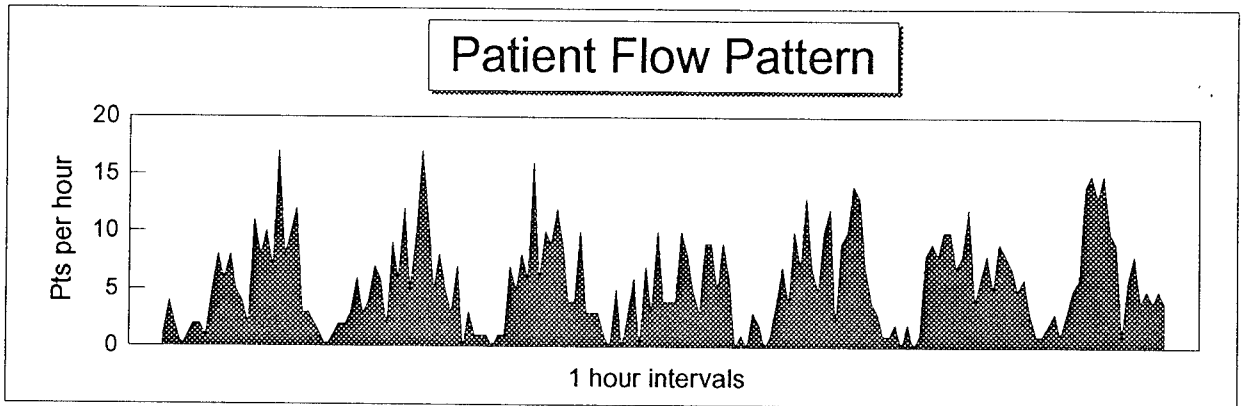

APPENDIX E
SOURCE CODE FOR GPSS/H MODEL
FLOW DIAGRAMS

Emergency Room Simulation

Start

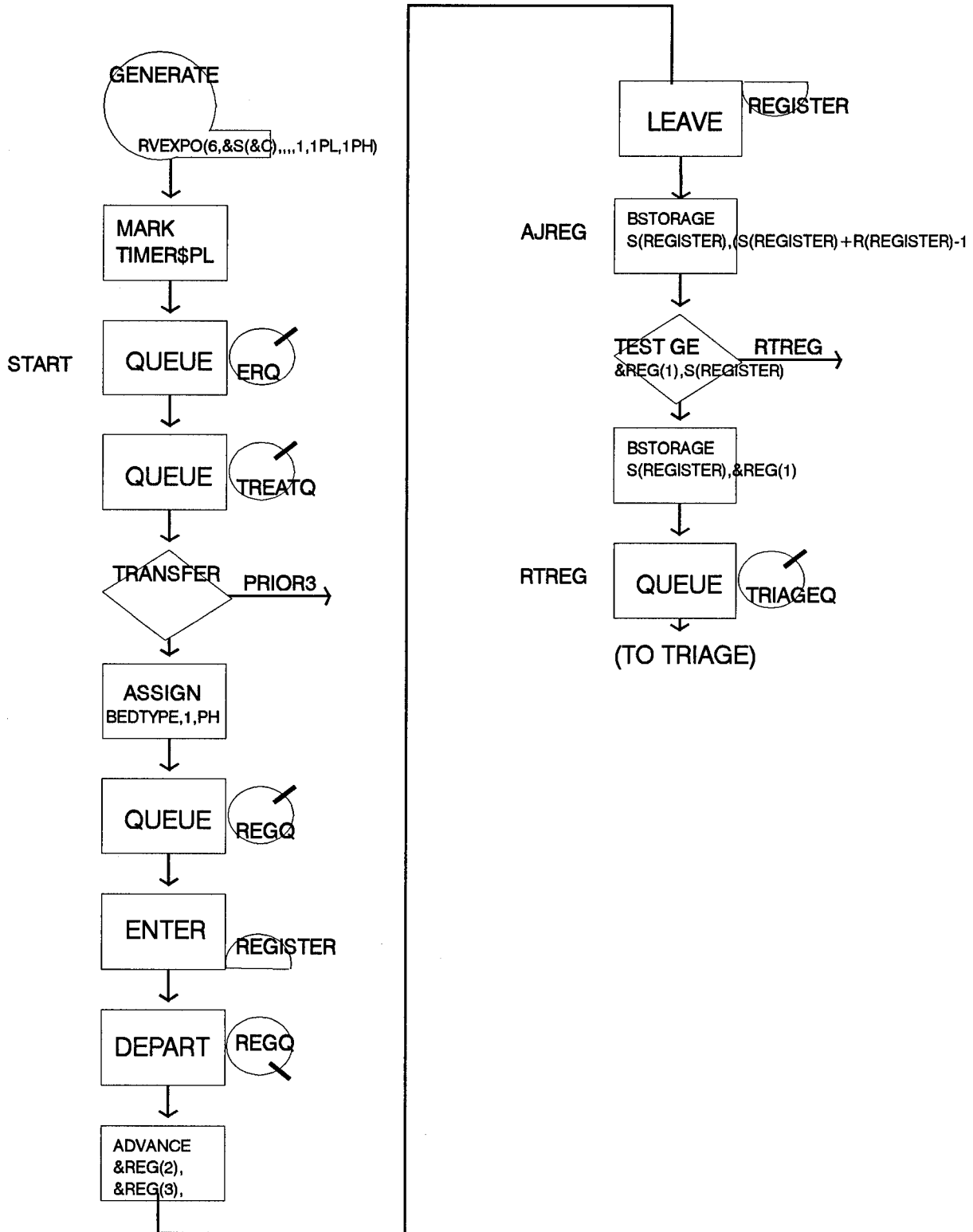

Triage

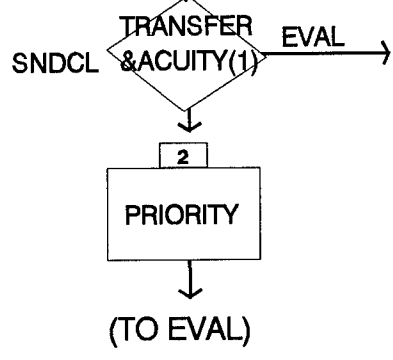
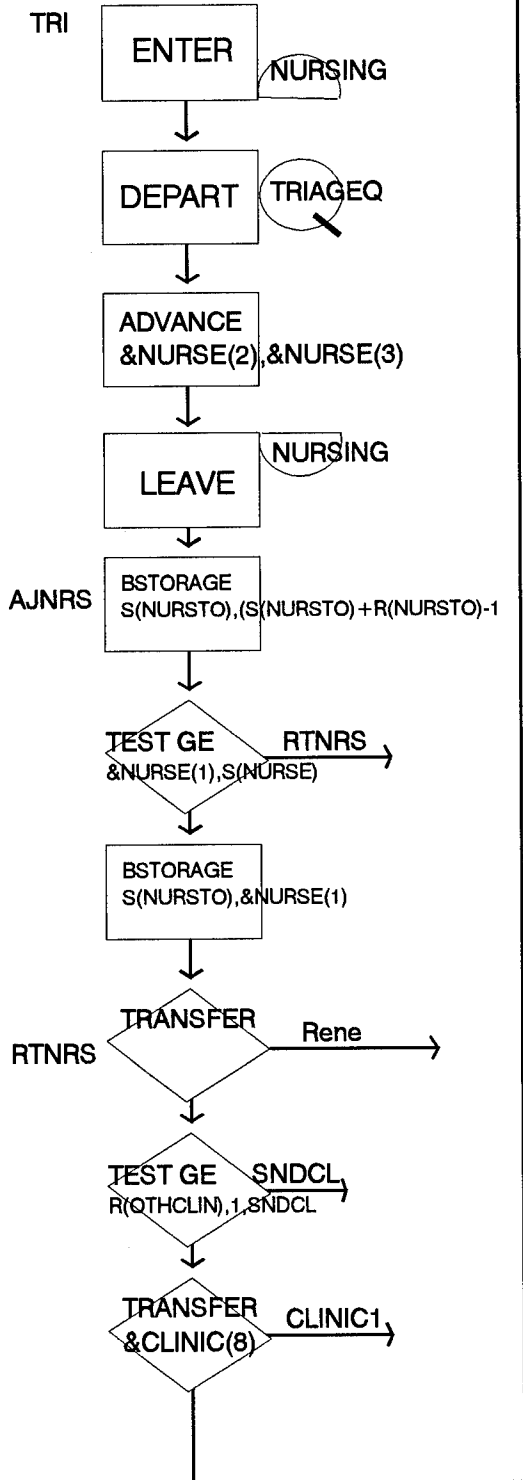

Renege

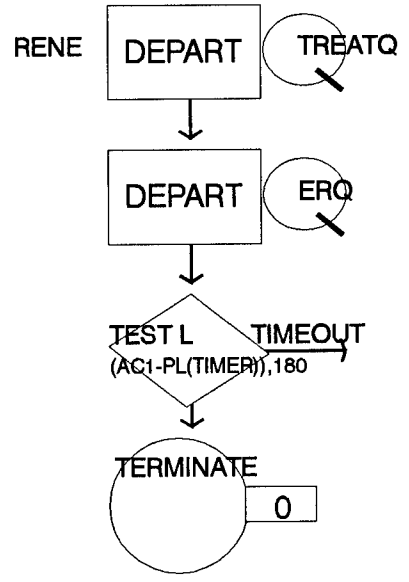

Evaluation

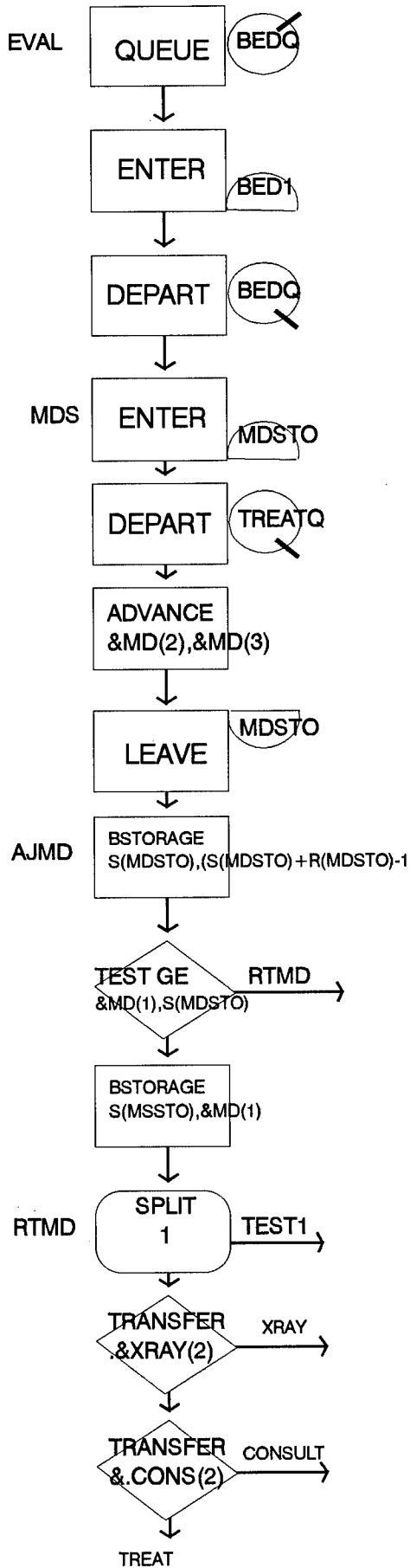

Treat

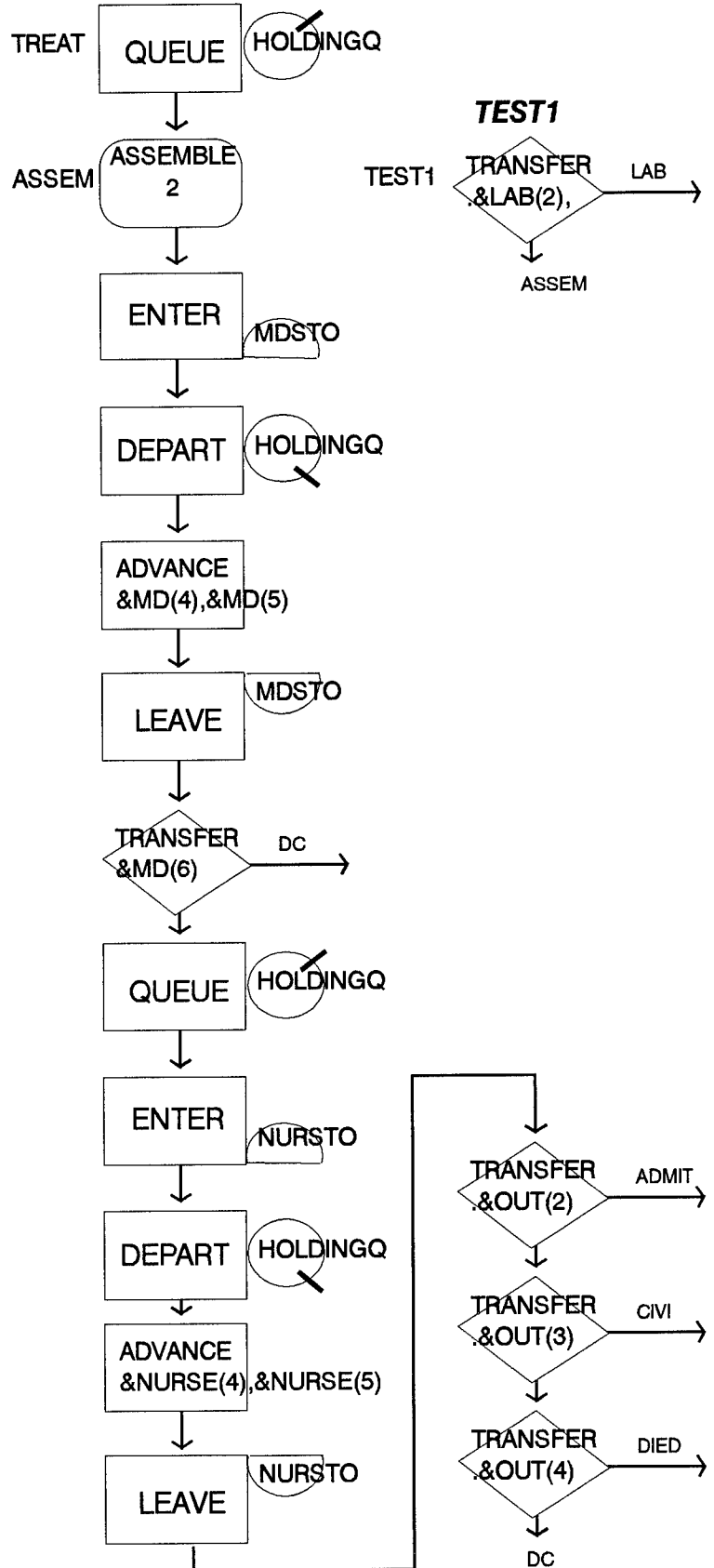

Laboratory

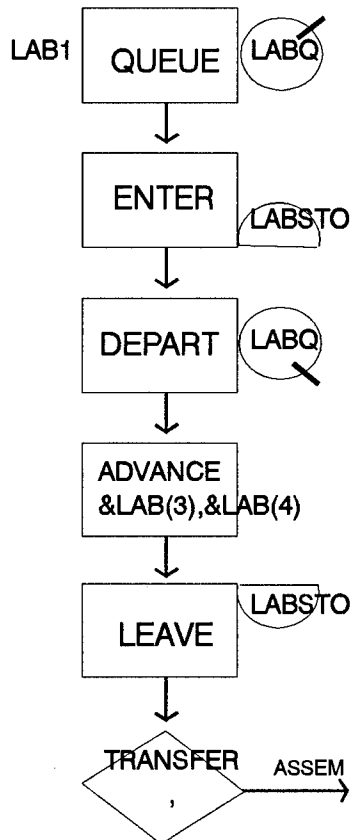

Radiology

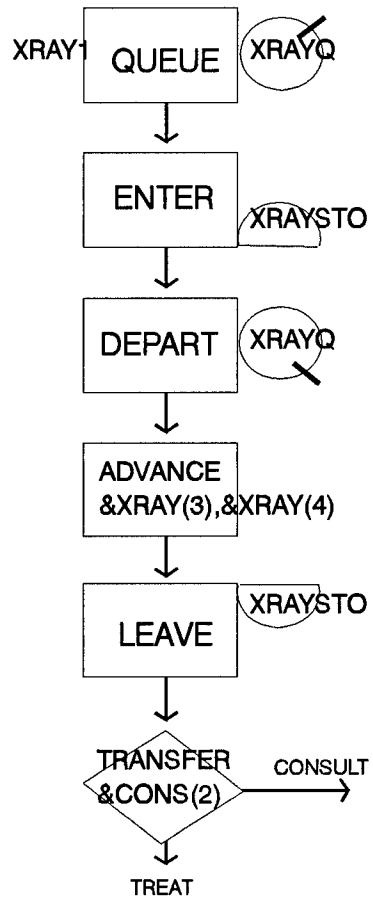

Consult

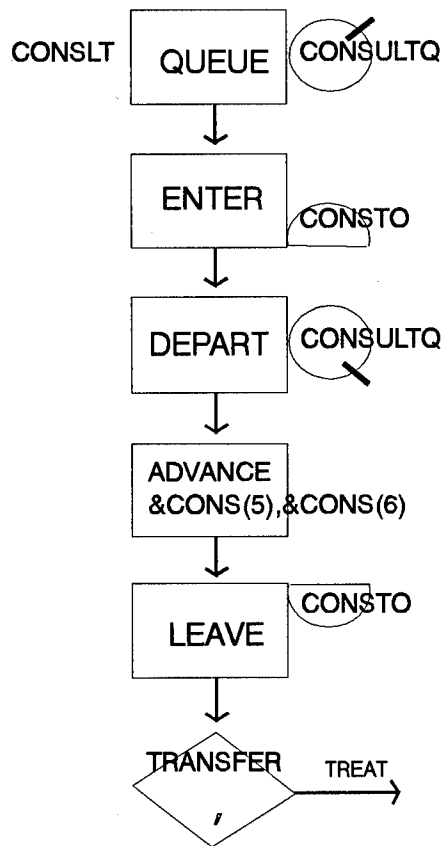

Admission

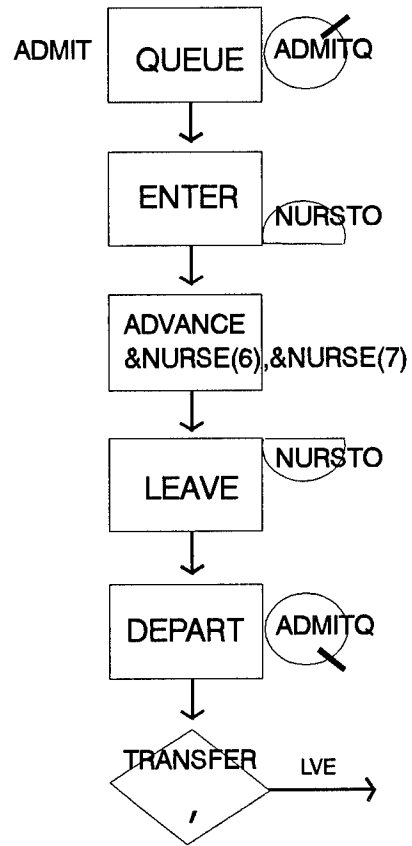

Transfer (to other facility)

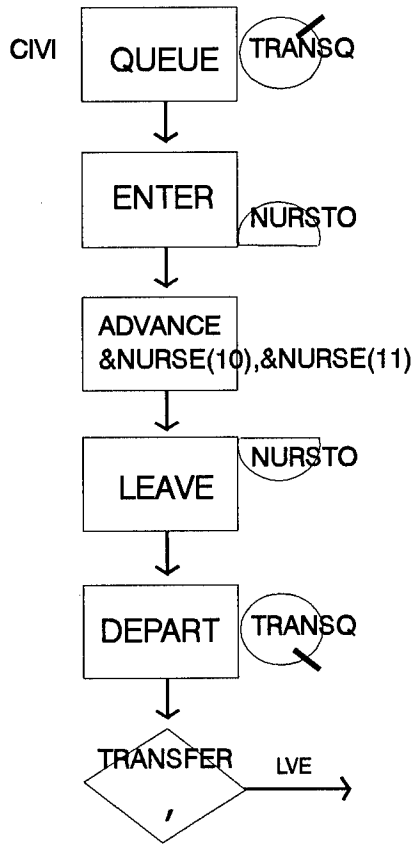

Discharge

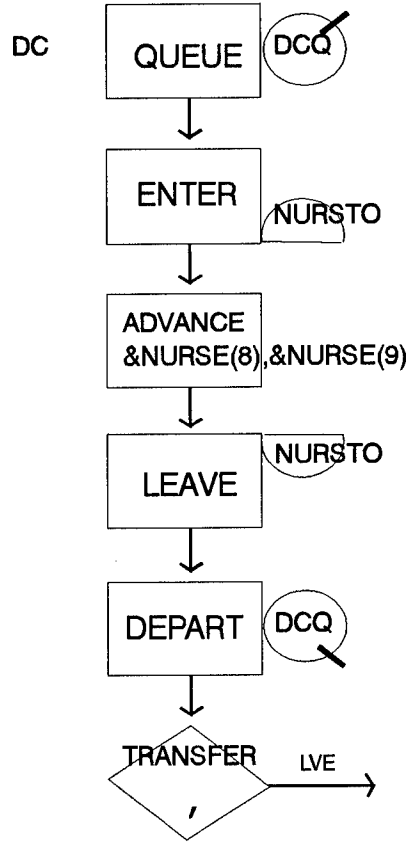

Died (in ER)

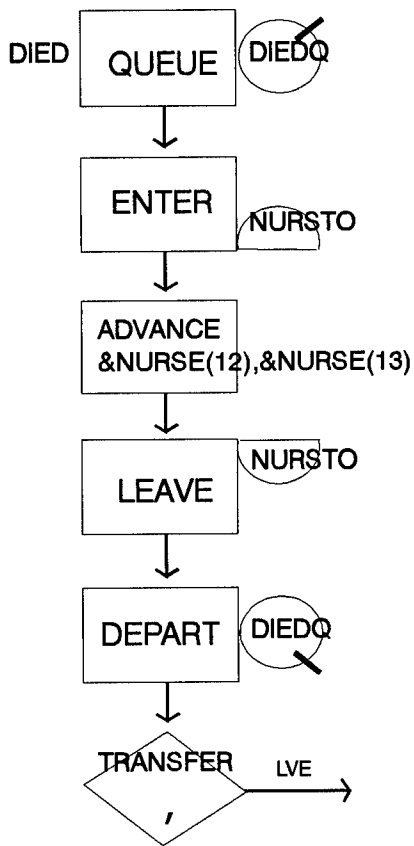

Clear Beds and ERQueue

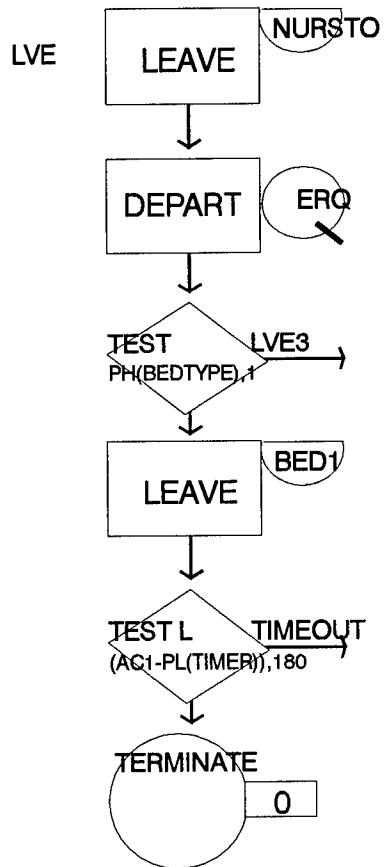

TIMEOUT

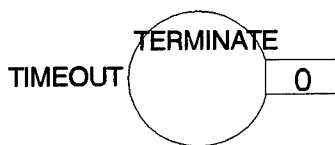

LVE3

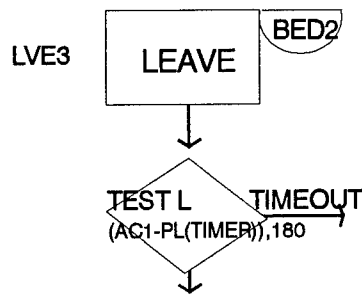

Emergent Patients

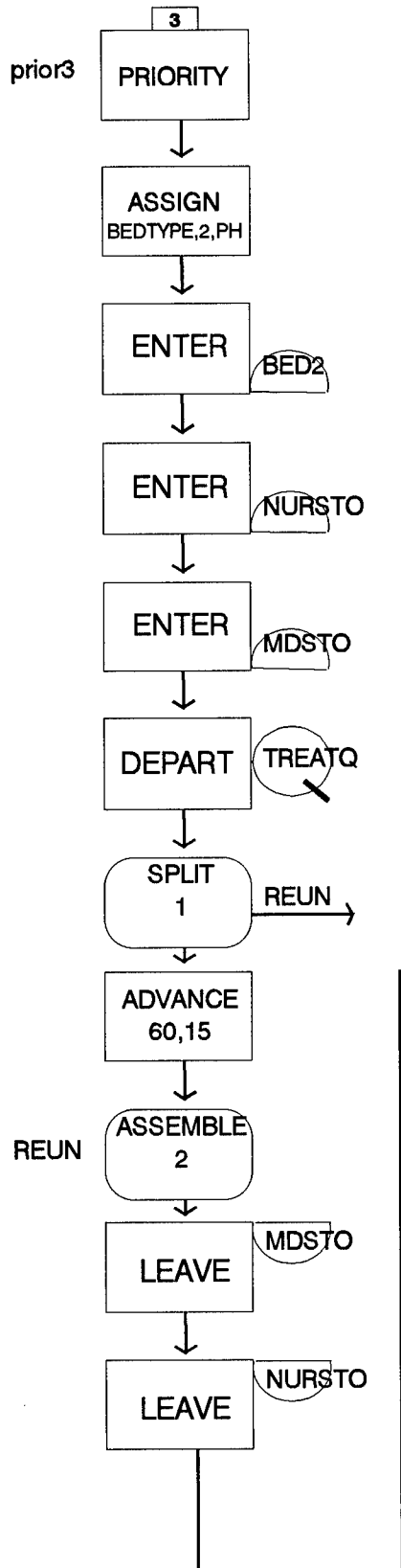

Timer Blocks

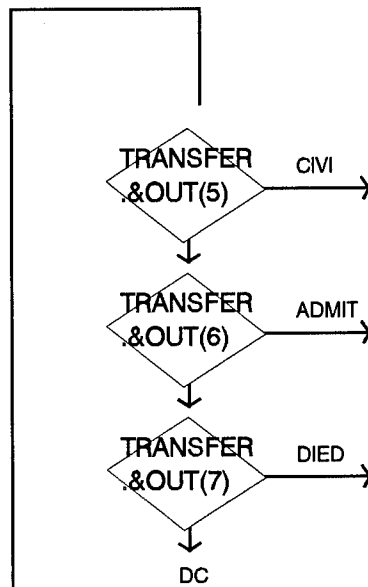
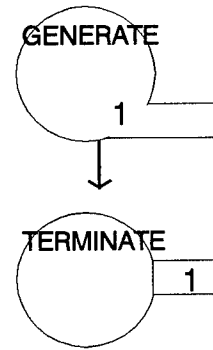

Other Clinics

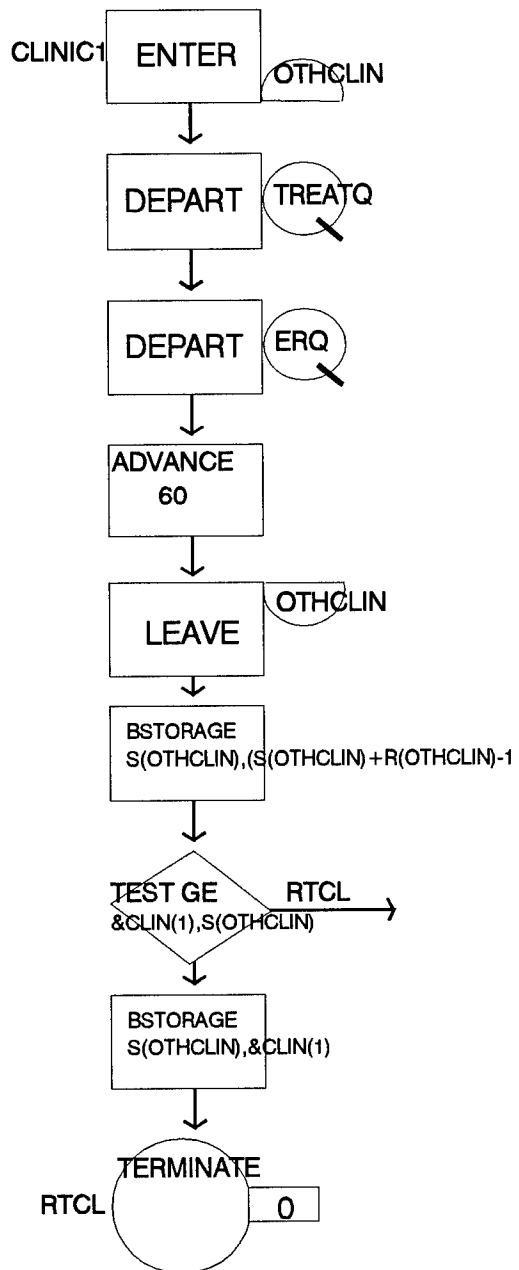

SOURCE CODE

```

1
2
3
4 *
5 *
6 *
7 *
8 *
9 *
10 *
11 *
12 *
13 *
14 *
15 *
16 *
17 *
18 *
19 *
20 *
21 *
22 *
23 *
24 *
25 *
26 *
27 *
28 *
29 *
30 *
31 *
32 *
33 *
34 *
35 *
36 *
37 *
38 *
39 *
40 *
41 *
42 *
43 *
44 *
45 *
46 *
47 *
48 *
49 *
50 *
51 *
52 *
53 *
54 *
55 *
56 *
57 *
58 *
59 *
60 *
61 *
62 *
63 *
64 *
65 *
66 *
67 *
68 *
69 *
70 *
71 *
72 *
73 *
74 *

```

```

=====
EMERGENCY ROOM SIMULATION
MARTIN ARMY COMMUNITY HOSPITAL
FORT BENNING, GEORGIA

AUTHOR: MAJOR TIMOTHY REESE, AN
15 APRIL 1994

=====
TIME UNITS = 1 MINUTE
REALLOCATE COM,27450
SIMULATE

=====
DECLARE AMPER VARIABLES
=====
INTEGER &I, &DAY, &C, &WEEK, &HOUR, &K, &J, &Q, &L, &R
REAL &S(48), &OUT(7), &ACUITY(3), &CLINIC(21), &CLIN
INTEGER &CLERK1(12), &CLERK2(12), &DOC1(12), &DOC2(12), &NSTAFF1(12), &NSTAFF2(12)
REAL &REG(3), &NURSE(14), &BED(2), &MD(6), &LAB(4), &XRAY(4), &CONS(6)

=====
OBTAIN VARIABLES FROM FILE
=====
GETLIST FILE=ERVARI, ((&REG(&I), &I=2,3), (&NURSE(&I), &I=2,14), (&BED(&I), &I=
1,2), (&MD(&I), &I=2,6), (&LAB(&I), &I=1,4), (&XRAY(&I), &I=1,4), (&CONS(&I), &I=
1,6), (&S(&I), &I=1,48), (&ACUITY(&I), &I=1,3), (&OUT(&I), &I=1,7), (&CLINIC(&I), &I=
1,21))

ZZ1 MATRIX ML,24,12 Savevalues for Registration Clerks (weekday)
ZZ2 MATRIX ML,24,12 Savevalues for Registration Clerks (weekend)
Y1 MATRIX ML,24,12 Savevalues for Nursing Staff (weekday)
Y2 MATRIX ML,24,12 Savevalues for Nursing Staff (weekend)
Z1 MATRIX ML,24,12 Savevalues for Physicians/PAs (weekday)
Z2 MATRIX ML,24,12 Savevalues for Physicians/PAs (weekend)
DO &K=1,24
GETLIST FILE=REG1, (&CLERK1(&I), &I=1,12)
GETLIST FILE=REG2, (&CLERK2(&I), &I=1,12)
GETLIST FILE=NURSE1, (&NSTAFF1(&I), &I=1,12)
GETLIST FILE=NURSE2, (&NSTAFF2(&I), &I=1,12)
GETLIST FILE=MDOC1, (&DOC1(&I), &I=1,12)
GETLIST FILE=MDOC2, (&DOC2(&I), &I=1,12)
DO &J=1,12
INITIAL ML$ZZ1(&K, &J), &CLERK1(&J)
INITIAL ML$ZZ2(&K, &J), &CLERK2(&J)
INITIAL ML$Y1(&K, &J), &NSTAFF1(&J)
INITIAL ML$Y2(&K, &J), &NSTAFF2(&J)
INITIAL ML$Z1(&K, &J), &DOC1(&J)
INITIAL ML$Z2(&K, &J), &DOC2(&J)
ENDDO
ENDDO

=====
DECLARE STORAGE
=====
BED1 STORAGE &BED(1) Regular treatment beds
BED2 STORAGE &BED(2) Trauma/Cardiac Bed
REGISTER STORAGE 1 Registration clerk(s)
MDSTO STORAGE 1 Physicians
LABSTO STORAGE &LAB(1) Laboratory assets
XRAYSTO STORAGE &XRAY(1) Radiology assets
CONSTO STORAGE &CONS(1) Consult physicians
NURSTO STORAGE 3 Nursing Staff

=====
MODEL BLOCK STATEMENTS
=====
GENERATE RVEXPO(6, &S(&C)),, ,1,1PL,1PH Arrive pts based on shift
function
MARK TIMER$PL Set marker for timing patients through
and default priority=1 (NONURGENT)

```

```

75 * ===== *
76 *           P A T I E N T   R E G I S T R A T I O N           *
77 * ===== *
78 START QUEUE   ERQ           Enter ERQ to gather overall wait time (3hr)
79 QUEUE   TREATQ       Begin wait for professional treatment (1hr)
80 *   TRANSFER .&ACUITY(3),,PRIOR3  Transfer % of patients to PRIOR3
81 ASSIGN  BEDTYPE,1,PH  Destin patient to regular bed
82 ENTER   REGISTER     Capture Registration Clerk
83 ADVANCE &REG(2),&REG(3) Register for the ER
84 LEAVE   REGISTER     Complete registration
85 AJREG  BSTORAGE S(REGISTER),(S(REGISTER)+R(REGISTER)-1)
86 TEST GE &REG(1),S(REGISTER),RTREG See if decrement okay
87 BSTORAGE S(REGISTER),&REG(1) Update the register storage
88 RTREG  QUEUE   TRIAGEQ       Wait for triage
89 *
90 * ===== *
91 *           T R I A G E           *
92 * ===== *
93 TRI  ENTER   NURSTO       Capture tech for triage and vital signs
94 DEPART TRIAGEQ       Complete wait for triage
95 ADVANCE &NURSE(2),&NURSE(3) Triage and vital signs process
96 LEAVE   NURSTO       Triage completed, ready for treatment
97 AJNRS  BSTORAGE S(NURSTO),(S(NURSTO)+R(NURSTO)-1)
98 TEST GE &NURSE(1),S(NURSTO),RTNRS See if decrement okay
99 BSTORAGE S(NURSTO),&NURSE(1) Update the nursing storage
100 RTNRS  TRANSFER .&OUT(1),,RENE % of patients renege and leave after triage
101 TEST GE R(OTHCLIN),1,SNDCL Test capacity of other clinics
102 TRANSFER .&CLINIC(8),,CLINIC1 Transfer % to another clinic
103 SNDCL  TRANSFER .&ACUITY(1),,EVAL Maintain % as NONURGENT patients
104 PRIORITY 2           % to be classified URGENT(2)
105 *
106 * ===== *
107 *           E V A L U A T I O N   A R E A           *
108 * ===== *
109 EVAL  QUEUE   BEDQ           Begin wait for treatment & more evaluation
110 ENTER   BED1           Gain access to regular treatment bed
111 DEPART  BEDQ           Complete wait for treatment bed
112 MDS    ENTER   MDSTO       Capture one of the MDs for evaluation
113 DEPART  TREATQ       Complete wait for Treatment (1hr)
114 ADVANCE &MD(2),&MD(3) Initial evaluation by physician
115 LEAVE   MDSTO       Complete MD initial evaluation and orders
116 AJMD   BSTORAGE S(MDSTO),(S(MDSTO)+R(MDSTO)-1)
117 TEST GE &MD(1),S(MDSTO),RTMD See if decrement okay, to AJMD if not
118 BSTORAGE S(MDSTO),&MD(1) Update the MD storage
119 RTMD   SPLIT   1,TEST1     Create specimen of patient
120 TRANSFER .&XRAY(2),,XRAY1 Send patients for xrays
121 TRANSFER .&CONS(2),TREAT,CONSLT Send patients for consults
122 *
123 TEST1  TRANSFER .&LAB(2),ASSEM,LAB1 Send patients for labs
124 *
125 * ===== *
126 *           E M E R G E N T   P A T I E N T S           *
127 * ===== *
128 *PRIOR3 PRIORITY 3           Make patients the highest priority
129 * ASSIGN  BEDTYPE,2,PH  Destin patient to Crashbed (BED2)
130 * ENTER   BED2           Gain the crashbed
131 * ENTER   MDSTO       Capture a physician
132 * DEPART  TREATQ       End wait for Treatment
133 * ENTER   NURSTO       Capture nursing staff
134 * SPLIT   1,REUN       Send off lab specimens
135 * ADVANCE 60,15        Obtain care and treatment
136 *REUN   ASSEMBLE 2           Put the patient together with his tests
137 * LEAVE   MDSTO       Complete care and treatment
138 * LEAVE   NURSTO       Complete care and treatment
139 * TRANSFER .&OUT(5),,ADMIT Admit % of patients
140 * TRANSFER .&OUT(6),,CIVI Transfer % of patients to civilian care
141 * TRANSFER .&OUT(7),DC,DIED % of emergent patients die in ER
142 *
143 * ===== *
144 *           L A B O R A T O R Y   P R O C E S S           *
145 * ===== *
146 LAB1  ENTER   LABSTO       Access laboratory assets -capacity defined?
147 ADVANCE &LAB(3),&LAB(4) Perform lab studies
148 LEAVE   LABSTO       Complete lab studies
149 TRANSFER ,ASSEM         Send results back to ER
150 *
151

```

```

152 * ===== *
153 *           R A D I O L O G Y   P R O C E S S           *
154 * ===== *
155 XRAY1  ENTER      XRAYSTO      Access radiology assets -capacity defined?
156       ADVANCE   &XRAY(3),&XRAY(4) Perform xray studies
157       LEAVE     XRAYSTO      Complete xray studies
158       TRANSFER .&CONS(2),TREAT,CONSLT Transfer some patients for consult
159 *
160 * ===== *
161 *           C O N S U L T   P R O C E S S           *
162 * ===== *
163 CONSLT ADVANCE &CONS(3),&CONS(4) Pending contact with consult MD
164       ENTER     CONSTO      Access consult MD -capacity defined?
165       ADVANCE  &CONS(5),&CONS(6) Perform consult evaluation
166       LEAVE    CONSTO      Complete consult
167       TRANSFER ,TREAT      Return to await ER MD Evaluation/Treatment
168 *
169 * ===== *
170 *           T R E A T M E N T   P R O C E S S       *
171 * ===== *
172 TREAT QUEUE  HOLDINGQ      Enter holding pattern waiting for MD eval
173 ASSEM ASSEMBLE 2          Place the patient together with lab results/clone
174       ENTER   MDSTO      Recapture MD for evaluation of labs/xrays/consults
175       DEPART  HOLDINGQ    Complete waiting for MD
176       ADVANCE &MD(4),&MD(5) Second eval or eval of labs/xrays/consults
177       LEAVE   MDSTO      Finished by MDs
178       TRANSFER .&MD(6),,DC Some pts ready for Discharge Process
179       QUEUE   HOLDINGQ    Awaiting treatment
180       ENTER   NURSTO      Access nursing personnel assets
181       DEPART  HOLDINGQ    Complete waiting for treatment
182       ADVANCE &NURSE(4),&NURSE(5) Treat problems (IVs, Sutures, Dsgs, etc)
183       LEAVE   NURSTO      Complete nursing staff care
184       TRANSFER .&OUT(2),,ADMIT Admit % of patients
185       TRANSFER .&OUT(3),,CIVI Transfer % of patients to civilian care
186       TRANSFER .&OUT(4),DC,DIED % of patients die in ER
187 *
188 * ===== *
189 *           D I S C H A R G E   P R O C E S S       *
190 * ===== *
191 DC     QUEUE    DCQ          Await discharge procedures/instructions
192       ENTER    NURSTO      Access nursing personnel assets
193       ADVANCE  &NURSE(8),&NURSE(9) Discharge instructions
194       DEPART   DCQ          End time in DC process
195       TRANSFER ,LVE        Leave Emergency Room
196 *
197 * ===== *
198 *           A D M I S S I O N   P R O C E S S       *
199 * ===== *
200 ADMIT QUEUE  ADMITQ          Await admission procedures
201       ENTER   NURSTO      Access nursing personnel assets
202       ADVANCE &NURSE(6),&NURSE(7) Process admission paperwork/communications
203       DEPART  ADMITQ      End time for admission process
204       TRANSFER ,LVE        Send all other patients out of ER
205 *
206 * ===== *
207 *           R E N E G E   P A T I E N T S           *
208 * ===== *
209 RENE  DEPART  TREATQ      End time waiting for Treatment (1hr)
210       DEPART  ERQ          Leave Emergency Room Queue (3hr)
211       TEST L  (AC1-PL(TIMER)),180,TIMEOUT Test to see if > 3 hr in ER
212       TERMINATE 0          Patient leaves the ER
213 *
214 * ===== *
215 *           T R A N S F E R   P R O C E S S         *
216 * ===== *
217 CIVI  QUEUE    TRANSQ      Await transfer procedures
218       ENTER    NURSTO      Access nursing personnel assets
219       ADVANCE  &NURSE(10),&NURSE(11) Process transfer paperwork/communications
220       DEPART   TRANSQ      End time for transfer process
221       TRANSFER ,LVE        Send all other patients out of ER
222 *
223 * ===== *
224 *           D I E D   P R O C E S S                 *
225 * ===== *
226 *DIED  QUEUE    DIEDQ      Await remains procedures
227       ENTER    NURSTO      Access nursing personnel assets
228       ADVANCE  &NURSE(12),&NURSE(13) Process death paperwork/communications
229       DEPART   DIEDQ      End time for death process
230       TRANSFER ,LVE        Send all other patients out of ER
231 *
232

```

```

233 * ===== *
234 * CLEAR BEDS AND ER QUEUE *
235 * ===== *
236 LVE LEAVE NURSTO Complete DC instructions
237 DEPART ERQ Leave Emergency Room Queue (3hr)
238 TEST E PH(BEDTYPE),1,LVE3 Send Emergent patients out of ER
239 LEAVE BED1 Empty bed for another patient
240 TEST L (AC1-PL(TIMER)),180,TIMEOUT Test to see if > 3 hr in ER
241 TERMINATE 0 Move patient out of ER
242 *
243 LVE3 LEAVE BED2 Empty Crashbed for another patient
244 TEST L MPL(TIMER),180,TIMEOUT Test to see if > 3 hr in ER
245 TERMINATE 0
246 *
247 * ===== *
248 * CHECK NUMBER OF PTS > 3 HR *
249 * ===== *
250 TIMEOUT TERMINATE 0 Clear patient from ER and count > 3 hr
251 *
252 * ===== *
253 * OTHER CLINICS *
254 * ===== *
255 CLINIC1 ENTER OTHCLIN Referred to other clinic
256 DEPART TREATQ Leave wait for treatment
257 DEPART ERQ Leave Emergency Room
258 ADVANCE 60 Set treatment time to 1 hour (allows pts/hr)
259 LEAVE OTHCLIN Complete treatment, allow another referral
260 BSTORAGE S(OTHCLIN), (S(OTHCLIN)+R(OTHCLIN)-1) Decrease capacity by one
261 TEST GE &CLIN,S(OTHCLIN),RTCL See if capacity change is okay
262 BSTORAGE S(OTHCLIN),&CLIN Change capacity to current value
263 RTCL TERMINATE 0 Clear patient from system
264 *
265 * ===== *
266 * TIMER BLOCK STATEMENTS *
267 * ===== *
268 GENERATE 1 Timer Block - Generate clock counter (minutes)
269 TERMINATE 1 Decrease counter by one
270 *
271 * ===== *
272 * CONTROL STATEMENTS *
273 * ===== *
274 LET &LAST=AC1 Initialize &LAST value to zero
275 DO &WEEK=1,15,1 Loop through 15 weeks
276 DO &DAY=1,7,1 Loop through Monday-Sunday
277 LET &NURSE(1)=3 Reset the number of nurses to 3
278 LET &MD(1)=1 Reset the number of MDs to 1
279 LET &REG(1)=1 Reset the number of Reg Clerks to 1
280 LET &Q=-11
281 DO &HOUR=1,24,1 Loop through hours (1-4)
282 *
283 LET &Q=&Q+1 Increase the counter for staffing loop
284 IF &DAY<=5 Check to see if Monday - Friday
285 LET &C=&HOUR
286 *
287 IF &HOUR=&CLINIC(2) Check peds clinic opening time
288 LET &CLIN=&CLIN+&CLINIC(1) Increase capacity to &CLIN
289 ELSEIF &HOUR=&CLINIC(3) Check peds clinic closing time
290 LET &CLIN=&CLIN-&CLINIC(1) Decrease capacity of &CLIN
291 ELSE
292 ENDIF
293 *
294 IF &HOUR=&CLINIC(6) Check FastTrac opening time
295 LET &CLIN=&CLIN+&CLINIC(5) Increase capacity to &CLIN
296 ELSEIF &HOUR=&CLINIC(7) Check peds clinic closing time
297 LET &CLIN=&CLIN-&CLINIC(5) Decrease capacity of &CLIN
298 ELSE
299 ENDIF
300 *
301 IF &HOUR=&CLINIC(10) Check other clinic opening time
302 LET &CLIN=&CLIN+&CLINIC(9) Increase capacity to &CLIN
303 ELSEIF &HOUR=&CLINIC(11) Check peds clinic closing time
304 LET &CLIN=&CLIN-&CLINIC(9) Decrease capacity of &CLIN
305 ELSE
306 ENDIF
307 *
308 DO &J=1,12,1 Cycle through different lengths of shifts
309 LET &REG(1)=&REG(1)+ML$Z1(&C,&J) Add the appropriate CLERKS
310 LET &NURSE(1)=&NURSE(1)+ML$Y1(&C,&J) Add the appropriate nurses
311 LET &MD(1)=&MD(1)+ML$Z1(&C,&J) Add the appropriate MDS
312 ENDDO
313 *

```

```

314         IF      &C<=13
315         DO      &L=2, &C, 1
316         LET    &REG(1)=&REG(1)-ML$ZZ1(&L-1, &C+1-&L)  Subtract CLERKS going off
317         LET    &NURSE(1)=&NURSE(1)-ML$Y1(&L-1, &C+1-&L)  Subtract nurses going off
318         LET    &MD(1)=&MD(1)-ML$Z1(&L-1, &C+1-&L)  Subtract MDS going off
319         ENDDO
320     *
321         ELSE
322         LET    &R=13
323         DO      &L=&Q, &C, 1
324         LET    &R=&R-1
325         LET    &REG(1)=&REG(1)-ML$ZZ1(&L-1, &R)          Subtract CLERKS going off
326         LET    &NURSE(1)=&NURSE(1)-ML$Y1(&L-1, &R)      Subtract nurses going off
327         LET    &MD(1)=&MD(1)-ML$Z1(&L-1, &R)          Subtract MDS going off
328         ENDDO
329     *
330     ENDIF
331     *
332     ELSE      Otherwise run Saturday and Sunday FN(x) shift
333     LET      &C=&HOUR+24      arrival rates (25 - 48)
334     *
335         IF      &HOUR=&CLINIC(14)  Check peds clinic opening time
336         LET    &CLIN=&CLIN+&CLINIC(13)  Increase capacity to &CLIN
337         ELSEIF &HOUR=&CLINIC(15)  Check peds clinic closing time
338         LET    &CLIN=&CLIN-&CLINIC(13)  Decrease capacity of &CLIN
339         ELSE
340         ENDIF
341     *
342     IF      &HOUR=&CLINIC(17)  Check FastTrac opening time
343     LET    &CLIN=&CLIN+&CLINIC(16)  Increase capacity to &CLIN
344     ELSEIF &HOUR=&CLINIC(18)  Check peds clinic closing time
345     LET    &CLIN=&CLIN-&CLINIC(16)  Decrease capacity of &CLIN
346     ELSE
347     ENDIF
348     *
349     *
350     *
351     *
352     *
353     *
354     *
355     *
356     DO      &J=1, 12, 1      Cycle through different lengths of shifts
357     LET    &REG(1)=&REG(1)+ML$ZZ2(&HOUR, &J)  Add the appropriate CLERKS
358     LET    &NURSE(1)=&NURSE(1)+ML$Y2(&HOUR, &J)  Add the appropriate nurses
359     LET    &MD(1)=&MD(1)+ML$Z2(&HOUR, &J)  Add the appropriate MDS
360     ENDDO
361     *
362     IF      &HOUR<=13
363     DO      &L=2, &HOUR, 1
364     LET    &REG(1)=&REG(1)-ML$ZZ2(&L-1, &HOUR+1-&L)  Subtract CLERKS going
365     off
366     LET    &NURSE(1)=&NURSE(1)-ML$Y2(&L-1, &HOUR+1-&L)  Subtract nurses going off
367     LET    &MD(1)=&MD(1)-ML$Z2(&L-1, &HOUR+1-&L)  Subtract MDS going off
368     ENDDO
369     *
370     ELSE
371     LET    &R=13
372     DO      &L=&Q, &HOUR, 1
373     LET    &R=&R-1
374     LET    &REG(1)=&REG(1)-ML$ZZ2(&L-1, &R)          Subtract CLERKS going off
375     LET    &NURSE(1)=&NURSE(1)-ML$Y2(&L-1, &R)      Subtract nurses going off
376     LET    &MD(1)=&MD(1)-ML$Z2(&L-1, &R)          Subtract MDS going off
377     ENDDO
378     *
379     ENDIF
380     *
381     ENDIF
382     *
383     START   60, NP          Set counter to 1 hour
384     PUTPIC
385     FILE=ERQUEUE, (N(START), QA(ERQ), QM(ERQ), QT(ERQ), QA(TREATQ), QM(TREATQ), QT(TREATQ), _
386     N(TIMEOUT), QM(TRIAGEQ), SR(BED1), SR(REGISTER), SR(MDSTO), SR(NURSTO))
387     *, *, *, *, *, *, *, *, *, *, *, *, *, *, *
388     RESET   Reset Relative clock
389     ENDDO   End Shift DO LOOP
390

```

```
391          PUTPIC  LINES=23, &WEEK, &DAY
392          +-----+
393          +
394          +
395          +
396          +
397          +
398          +
399          +
400          +
401          +
402          +
403          +           WEEK   **                DAY   **
404          +
405          +
406          +
407          +
408          +
409          +
410          +
411          +
412          +
413          +
414          +-----+
415          ENDDO          End Day DO LOOP
416          ENDDO          End Week DO LOOP
417          *
418          * ===== *
419          *          END          **** END PROGRAM ****
420          * ===== *
421          *
```