

DTIC
SELECTED
MAR 29 1995

EEDP-02-15
October 1991



Environmental Effects of Dredging Technical Notes



Technical Considerations for Application of Leach Tests to Sediments and Dredged Material

Purpose

This note summarizes the characteristics of and differences among laboratory leach tests used for preproject evaluation of leachate quality in confined disposal facilities (CDFs) for dredged material. The guidance provided in this note is based on ongoing research conducted under the Long-Term Effects of Dredging Operations (LEDO) Program.

Background

Contaminated dredged material is sometimes placed in CDFs where the potential for movement of contaminants to groundwater and surrounding surface water by leaching is an important environmental concern. The US Army Corps of Engineers (USACE) has initiated a laboratory program of CDF leachate investigations by developing a theoretical framework for prediction of leachate quality based on contaminant transport theory. The laboratory tests and theoretical framework under development by the USACE provide estimates of leachate quality in CDFs as elution histories related to the amount of water percolating through dredged material. The US Environmental Protection Agency (EPA) Toxicity Characteristic Leach Procedure (TCLP) is also sometimes used to provide predictions of dredged material leachate quality. The USACE leachate tests under development and the TCLP are reviewed in this technical note.

Additional Information

For additional information, contact one of the authors, Mr. Tommy E. Myers, (601) 634-3939, or Dr. James M. Brannon, (601) 634-3725, or the manager of the Environmental Effects of Dredging Programs, Dr. Robert M. Engler, (601) 634-3624.

19950327 210

Approved for public release
Distribution Unlimited

Need for Predictive Techniques

When contaminated dredged material is placed in a confined disposal facility (CDF), contaminants may be transported to site boundaries by leachate generation and seepage. Subsurface seepage through foundation soils and dikes may then reach adjacent surface water and groundwater and act as a source of contamination (Figure 1). Section 404 of the Clean Water Act of 1972, as amended, the National Environmental Policy Act of 1969, and the US Army Corps of Engineers (USACE) management strategy for dredged material disposal (Francingues and others 1985) require evaluation of the confined disposal alternative for dredged material to include groundwater impacts. The information for preproject evaluation of leachate impacts on groundwater resources will necessarily come from some type of laboratory leach test(s) conducted on sediments before dredging and disposal. Thus, leach tests and predictive techniques that use leach data are needed to establish sound engineering and environmental data for the selection, design, operation, and management of CDFs.

USACE Approach to Leachate Quality Prediction

In the USACE leachate research, theoretical contaminant transport equations are being used to determine what type of information laboratory leach tests should provide. The basic equations are shown in Figure 2. Equations 1 and 2 in the figure couple porous media fluid mechanics (convection and dispersion) with chemistry (interphase transfer of contaminants from sediment solids to pore water). Since most of the contaminants in dredged material are adsorbed to sediment solids, leaching in a CDF is defined as interphase transfer of contaminant mass from sediment solids to pore water. The leach tests under development by the USACE focus on quantitation and mathematical description of contaminant

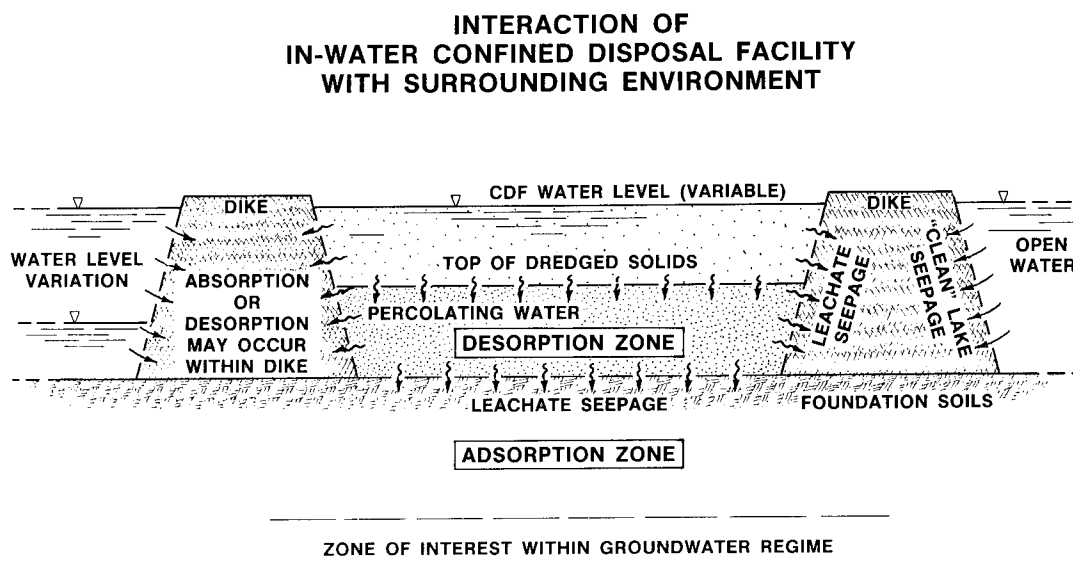

Figure 1. Contaminant migration pathway: leachate seepage

transfer from dredged material solids to pore water. Figure 3 illustrates the important processes and factors affecting leachate quality in dredged material. As shown in Figure 3, interphase transfer during dredged material leaching is a complicated interaction of many elementary processes and factors affecting these processes.

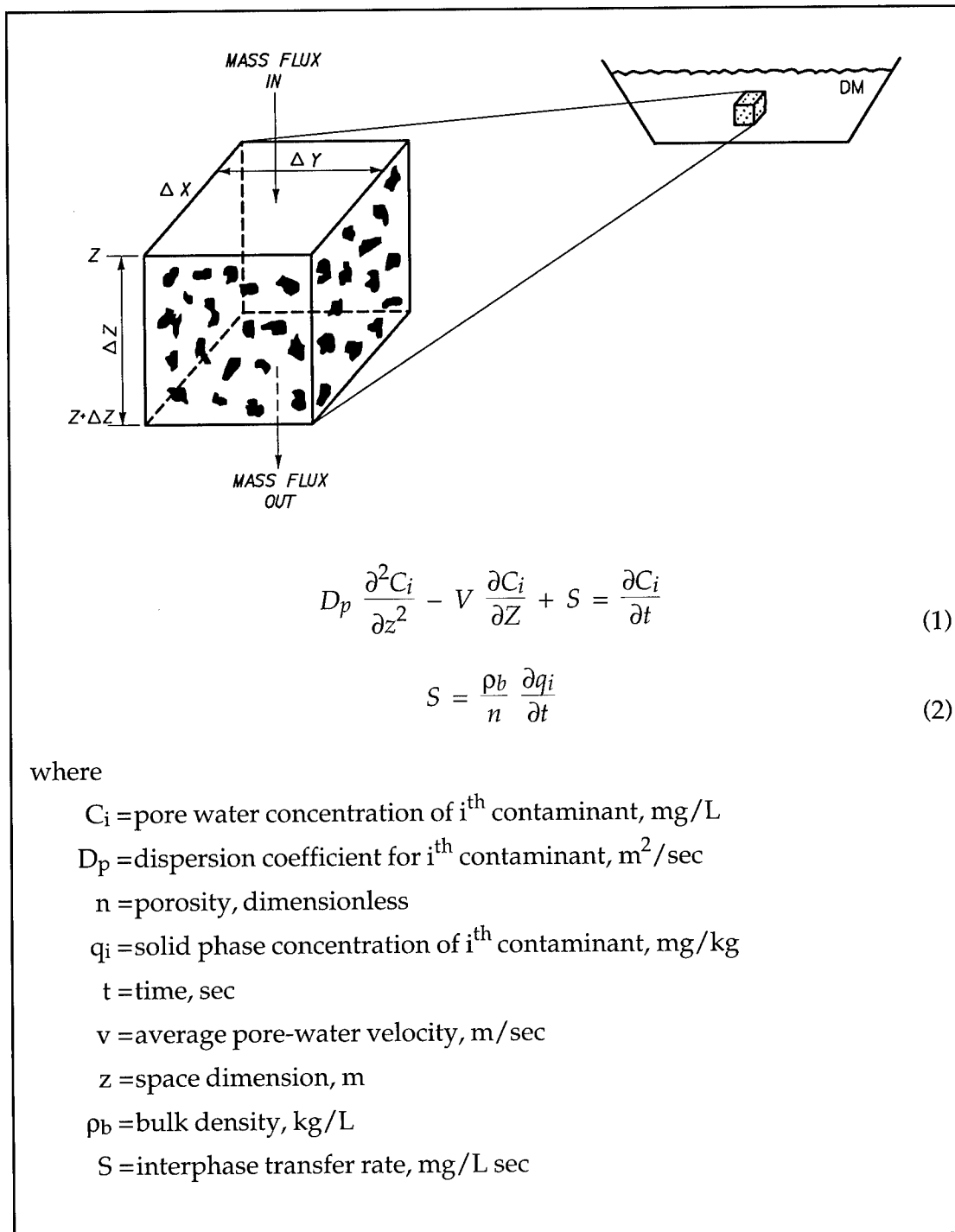

Figure 2. Mathematical model of dredged material leaching

Accession For	
NTIS CRA&I	✓
DTIC TAB	
Unannounced	
Justification	
By <i>Doc Form 50</i>	
Distribution /	
Availability Co	
Dist	Avail and / Special
A-1	

Factors Affecting Leachate Quality

Site-specific Factors

Contaminant mobilization in dredged material is regulated to a large extent by the physicochemical environment of the dredged material disposal site (Gambrell, Khalid, and Patrick 1978). The important site-specific physicochemical parameters for dredged material are oxidation-reduction potential (redox), pH, and ionic strength. Redox and pH determine the speciation and solubility of many chemical constituents, especially metals. Ionic strength affects the solubility of metals and organics, speciation of metals, and the stability of the sediment colloidal system (Stumm and Morgan 1981, Brannon and others 1991). Each of these factors should be considered in development and application of leach tests.

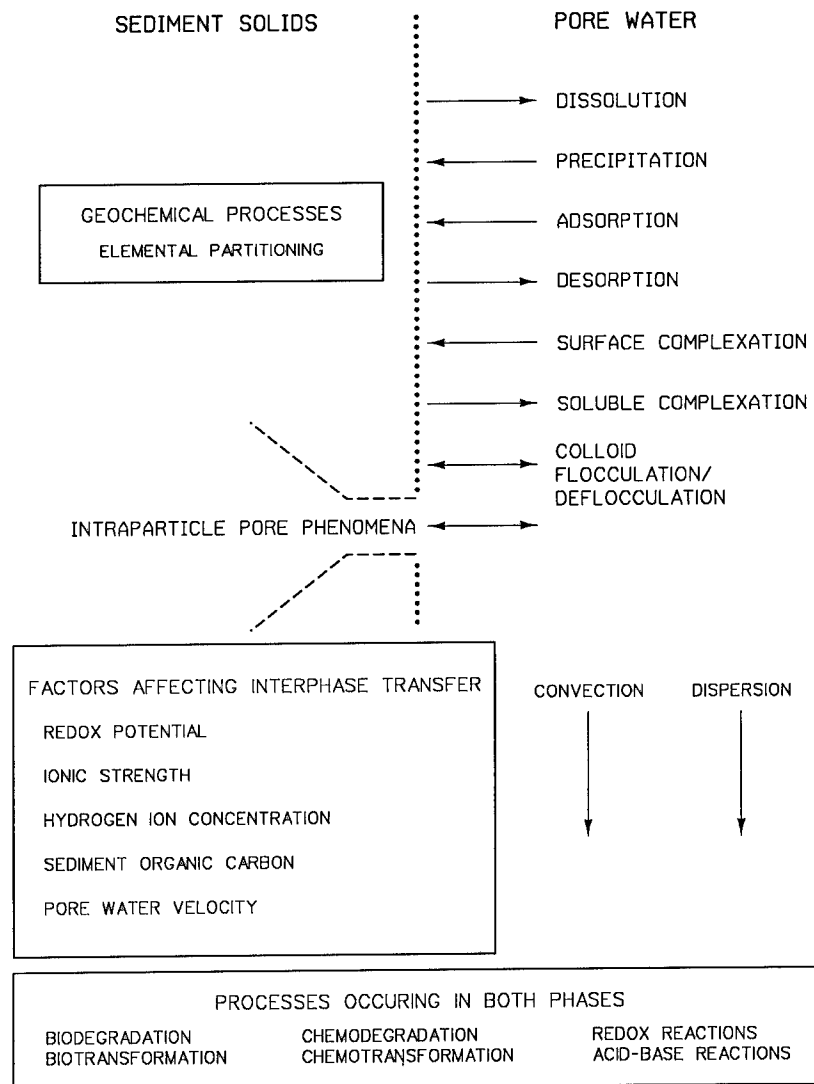

Figure 3. Interphase transfer processes and factors affecting interphase transfer processes

Test-specific Factors

In leach tests, liquid-solids ratio, contact time, and shear at the particle-water interface are test-specific parameters that affect leachate contaminant concentrations. The liquid-solids ratio is the ratio of the mass of water to the mass of dry solids; contact time in a batch leach test refers to the lapse time between introduction and removal of water. Contact time in a column leach test refers to the time required for elution of one pore volume. For a wide range of contaminants, the distribution of contaminant between solid and aqueous phases has been shown to depend on the liquid/solids ratio (O'Connor and Connolly 1980, Voice, Rice, and Weber 1983, DiToro 1985, Gschwend and Wu 1985). Contact time also affects the amount of contaminant that is leached. Another parameter affecting leachate contaminant concentrations in leach tests is the shear at the particle-water interface. The slower the water velocity across particle surfaces, the thicker the film of immobile water that contaminants must diffuse through.

CDF Conditions

Typical fine-grained sediments are anoxic (reducing) and have a pH near neutrality. Dredging and disposal results in short-term perturbations of the sediment redox regime, but due to the high oxygen demand of most sediments, initial leaching in CDFs occurs under anaerobic conditions. If a CDF is not managed to remove ponded water, most of the dredged material will remain anaerobic. If the CDF is managed to remove ponded water, the upper layer of dredged material will gradually transition from an anaerobic to an aerobic condition. This transition is characterized by drying and cracking of the surface and development of an aerobic crust which may eventually be several feet thick. CDFs containing fine-grained dredged material, however, never completely drain, resulting in a saturated layer at the bottom where anaerobic conditions persist.

Thus, leaching in a CDF can occur under redox conditions ranging from mildly aerobic to strongly anaerobic. In anaerobic soils and sediments, pH is buffered near neutrality by the substances produced as a result of microbial utilization of iron and manganese as electron acceptors (Patrick and Mikkelsen 1971, Ponnamperuma 1972, and Brannon and others 1978). Thus, the leachate that seeps into foundation soils is anaerobic and near neutral in pH. The aerobic microbial metabolism in the unsaturated crust of a CDF often results in a lowering of pH. The amount that pH is lowered depends on sediment geochemistry. In low sulfur sediments that are high in carbonates, the condition of many freshwater sediments, pH under aerobic conditions may not differ significantly from that under anaerobic conditions. In estuarine sediments, oxidation of sulfide to sulfate can decrease pH by one to three pH units relative to the pH under anaerobic conditions. Thus, leachate that seeps from the crust may be acidic as well as aerobic, depending on sediment geochemistry. Contact of aerobic-acidic leachate with anaerobic sediment results in an anaerobic near-neutrality in pH leachate (Environmental Laboratory 1987). Thus, percolation of aerobic-acidic leachate from an unsaturated-aerobic crust into saturated-anaerobic layers beneath a crust does not

alter the redox or pH of leachate in dredged material beneath the crust. Leachate that seeps from the crust into confining dikes may, however, be aerobic and acidic.

Pore-water ionic strength depends on the salinity of the dredged material and is a function of the amount and salinity of water that infiltrates the dredged material. In general, the in situ ionic strength will persist for many years before all of the salt in estuarine dredged material is washed out. For freshwater dredged material, there is little change in ionic strength as the dredged material is leached by fresh water.

The liquid-solids ratio in a filled CDF is less than 1:1. During filling, the liquid-solids ratio in the dredged material depends on the type of dredging and disposal operation. For mechanical dredging and disposal, the liquid-solids ratio applicable to leachate generation does not differ significantly from 1:1 at any time during the filling process. During hydraulic dredging and disposal, the influent to the CDF will have a liquid-solids ratio of about 4:1. In the solids that settle and consolidate in the bottom of the CDF, the liquid-solids ratio will initially be about 4:1 or less and will decrease with time as solids consolidate. The CDF effluent associated with hydraulic filling will have a substantially higher liquid-solids ratio, but this liquid-solids ratio is not representative of the liquid-solids ratio in the dredged material that produces leachate.

The shear at particle surfaces associated with dredged material leaching in CDFs is very low because pore-water velocities are low. Pore-water velocities are low because the hydraulic conductivity of fine-grained dredged material is usually very low (10^{-8} to 10^{-5} cm/sec). Mass transfer limitations to the leaching of contaminants from dredged material under these conditions could be important.

Leach Test Comparisons

Table 1 lists test conditions for the Toxicity Characteristic Leach Procedure (TCLP) and two leach tests under development at the US Army Engineer Waterways Experiment Station (WES), a sequential batch leach test (SBLT) and a column leach test. Typical CDF conditions are also listed in Table 1 for reference. The TCLP and the leach tests under development at WES are discussed in more detail in the following sections.

TCLP

The TCLP was developed by the US Environmental Protection Agency (EPA) for determining if a nonlisted waste is a hazardous waste. The regulatory purpose of the TCLP is to identify wastes that although not specifically listed in 40 Code of Federal Regulations 261 as hazardous, pose substantial hazard when improperly managed. This test, developed to accomplish a specific regulatory purpose under the Resource Conservation and Recovery Act (RCRA) of 1976, as amended (USEPA 1990) is sometimes used to assess the leaching potential of Superfund sediments.

Table 1. Comparison of Leach Test Variables

	TCLP	WES-SBLT	WES-Column	CDF
pH	pH 4.9 or pH 2.9 fluid	neutral/self adjusting	neutral/self adjusting	neutral/self adjusting
ORP	no control	anaerobic/aerobic	anaerobic	anaerobic/aerobic
Liquid-Solids Ratio	20:1	4:1	< 1:1	< 1:1
Agitation	tumbler	tumbler	none	none
Long-Term Predictive Capability	none	implied from mass transport theory	implied from mass transport theory	self evident
Contact Time	18 hours	24 hours	weeks	years

The TCLP is a criteria-comparison type test in which results from a standardized leach procedure are compared with a specific set of criteria. The test is conducted in one of two modes (nonvolatiles or volatiles) and consists of several parts as outlined in Figure 4. Figure 4 applies to both the nonvolatiles TCLP and the volatiles TCLP. The double lines in Figure 4 indicate the path normally taken for sediments.

The pre-extraction part of the test involves removal of water by vacuum or pressure filtration, removal of particles larger than 9.5 mm, and selection of a leaching fluid. For the volatiles TCLP, dilute acetic acid adjusted to pH 4.93 (Fluid No. 1) is used as the leaching fluid. For the nonvolatiles TCLP, the acid neutralization capacity of the material to be leached is evaluated, and on the basis of this information either Fluid No. 1 or dilute acetic acid at pH 2.9 (Fluid No. 2) is used as the leaching fluid. The water removed by filtration is combined with the TCLP extract developed later in the test. The solids and leaching fluid are agitated at a liquid-solids ratio of 20:1 on a tumbler for 18 hours, and the fluid and solids are separated by filtration. The liquid obtained in the pre-extraction filtration is combined with the acetic acid extract and defined as the TCLP extract.

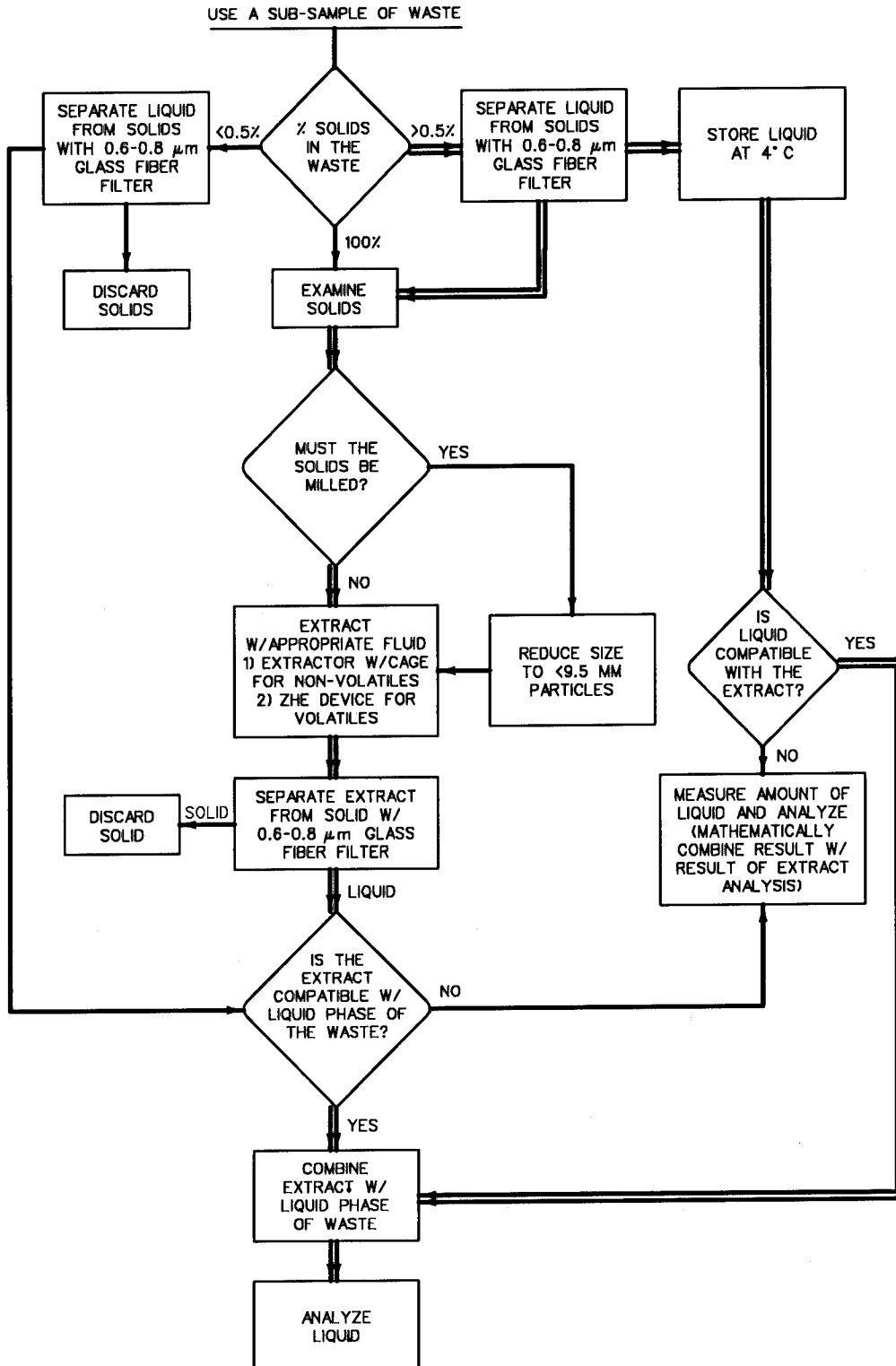

Figure 4. TCLP flowchart

WES-SBLT

In the WES-SBLT, sediment solids are challenged with successive aliquots of distilled-deionized water in an agitated system. After the aqueous and solid phases have reached steady-state, the phases are separated by centrifugation and filtration, and the leachate is analyzed for contaminants of concern. The solid phase is then reequilibrated with fresh distilled-deionized water, and the process of phase separation and leachate analysis is repeated. Each cycle in the WES-SBLT involves an equilibration step, a phase separation step, and a leachate analysis step (Figure 5). A table of solid phase and aqueous phase concentrations is developed from chemical analysis of the leachates, and these data are plotted to produce desorption isotherms. From the desorption isotherms, contaminant-specific equilibrium distribution coefficients, K_{ds} , are obtained.

Figure 6 shows cadmium and zinc desorption isotherms prepared from WES-SBLT tests conducted on sediment from Indiana Harbor, Indiana (Environmental Laboratory 1987). The isotherm slopes are the K_{ds} used to predict elution curves from column leach tests.

WES-SBLTs are conducted under nitrogen (anaerobically) to simulate the anaerobic conditions that prevail throughout most of a CDF and in the presence of air to simulate the aerobic condition of the surface crust that forms as a CDF dewateres. In anaerobic testing, the sediment as received is anaerobic, and all operations involving loading centrifuge bottles and filtration are conducted under a nitrogen atmosphere to avoid oxidation of iron, manganese, and sulfur. In the aerobic testing, sediment is aged six months in the presence of air. During the aging process, moist conditions are maintained by periodic additions of water, and the sediment is stirred manually on a daily basis. Testing has shown that the mobility of contaminants under anaerobic and aerobic conditions is substantially different (Environmental Laboratory 1987, Myers and Brannon 1988, and Palermo and others 1989). This is to be expected based on the environmental chemistry of iron and sulfur.

The pH level in the WES-SBLT depends on sediment biogeochemistry and leaching conditions (anaerobic or aerobic). The appropriate

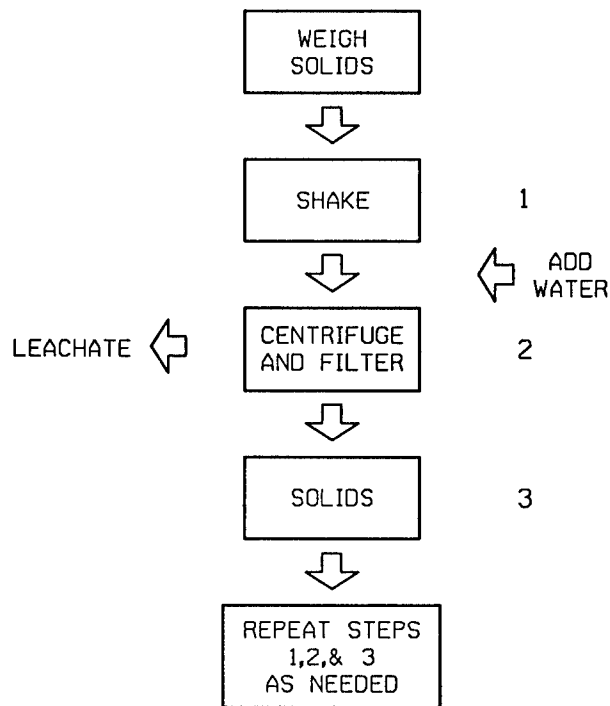

Figure 5. Schematic of WES-SBLT

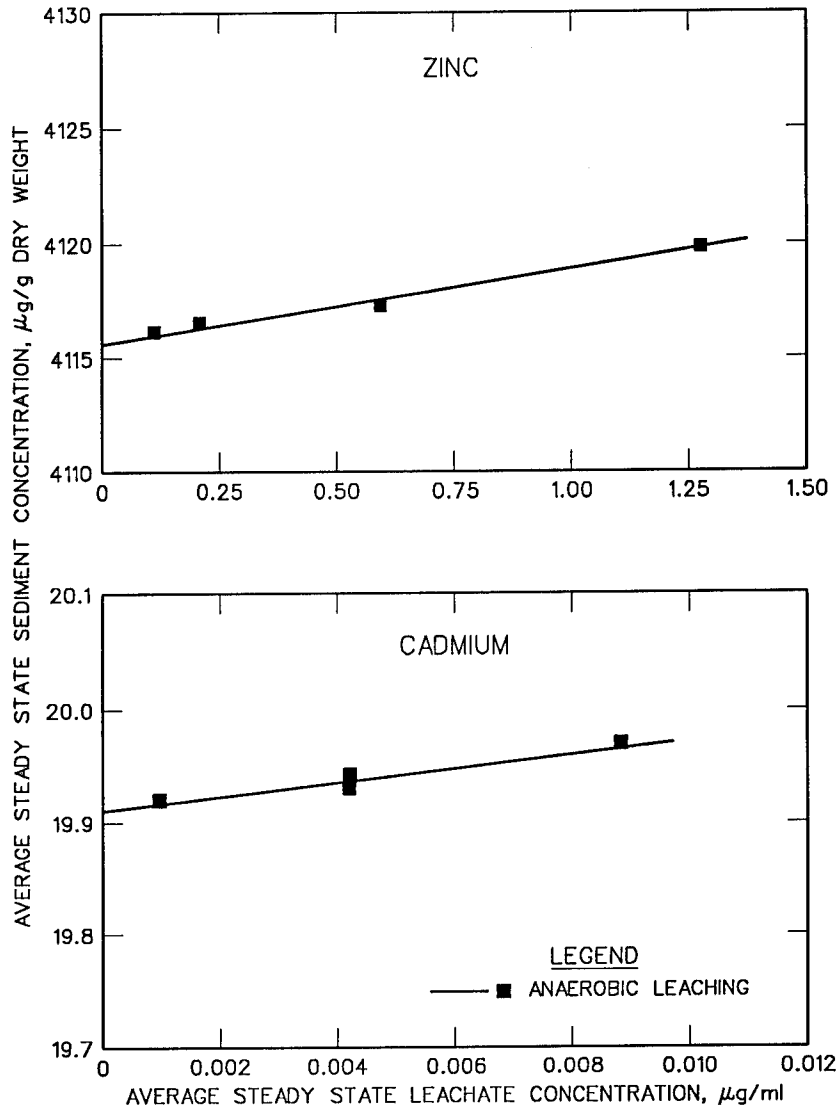

Figure 6. Desorption isotherms for zinc and cadmium in Indiana Harbor sediment (Environmental Laboratory 1987)

conditions for microbial adjustment of pH are maintained in the WES-SBLT by conducting the test as anaerobic or aerobic. Because there are no artificial adjustments of pH, the WES-SBLT allows the sediment biogeochemistry to adjust pH to values that are representative of field pH in anaerobic (saturated) and aerobic (unsaturated) zones.

The contact time for the WES-SBLT is still in a research and development stage. However, kinetic batch testing on three sediments has shown that a 24-hour shake time represents steady-state conditions for most contaminants (Environmental Laboratory 1987, Myers and Brannon 1988, and Palermo and others 1989). Investigation of desorption kinetics in additional sediments is ongoing.

As previously discussed, distribution coefficients determined at one liquid-solids ratio may not be appropriate at another if the liquid-solids ratios differ by orders of magnitude. Testing has shown that a 4:1 liquid-solids ratio is the lowest practical ratio for conducting batch leach tests with sediment (Environmental Laboratory 1987, Myers and Brannon 1988, and Palermo and others 1989). It is anticipated the final WES-SBLT recommended for adoption will include a liquid-solids ratio of 4:1.

WES-Column

Sequential batch leach tests, useful for determining the kinetics of desorption, equilibrium distribution coefficients, and long-term leaching characteristics, cannot simulate the advective-dispersive and other mass transfer effects occurring in a CDF. Column leach tests provide a laboratory-scale physical model of leaching in a CDF. The purpose of batch and column testing is to demonstrate that contaminant elution in a continuous flow system can be predicted using information from batch studies.

Elution histories predicted using batch-determined distribution coefficients have qualitatively agreed with observed column elution histories, but quantitatively the predicted and observed elution histories were not always in good agreement (Environmental Laboratory 1987, Myers and Brannon 1988, and Palermo and others 1989). A workshop organized to review the WES studies on sediment leaching identified problems with some of the column data and recommended redesign of the column leach apparatus (Louisiana Water Resources Research Institute 1990).

Figure 7 shows an improved column leaching apparatus for sediments and dredged material that replaces the columns used in previous studies (Myers, Titlebaum, and Gambrell 1991). The new design overcomes some of the shortcomings of the column apparatus used previously. This design minimizes wall effects by having a large column diameter-to-particle diameter ratio, minimizes run time for obtaining elution curves by having a short column length, and provides sufficient sample volume for chemical analysis since the flow-through area is large. Columns based on the new design have been constructed and are being used in ongoing dredged material leaching studies.

Integrated Approach

This approach consists of using results from batch and column leach tests and Equations 1 and 2 from Figure 2 to verify the form of an assumed interphase transfer term. Application of the integrated approach is illustrated in Figure 8. If predicted and observed column elution curves agree, the conclusion may be reached that the processes governing transfer of contaminants from dredged material solids to pore water has been adequately described. If not, other formulations for interphase transfer may be needed. Once interphase transfer has been adequately described, contaminant migration by leaching can be evaluated for the flow conditions that apply in the field.

Critique of Leach Tests

TCLP

In terms of certain test conditions, such as liquid-solids ratio and pH, the TCLP is not a true analog of disposal site conditions for dredged material. As previously noted, the pH of leachate at the bottom of CDFs is near neutrality. The pH regime of the TCLP, designed to simulate conditions in a sanitary landfill, is therefore inappropriate. Equally inappropriate is the liquid-solids ratio used in the TCLP. Probably the most significant deficiency of the TCLP is the failure to provide proper redox control during the tests. The arbitrarily selected liquid-solids ratio and method of agitation do not provide for a well-defined redox condition.

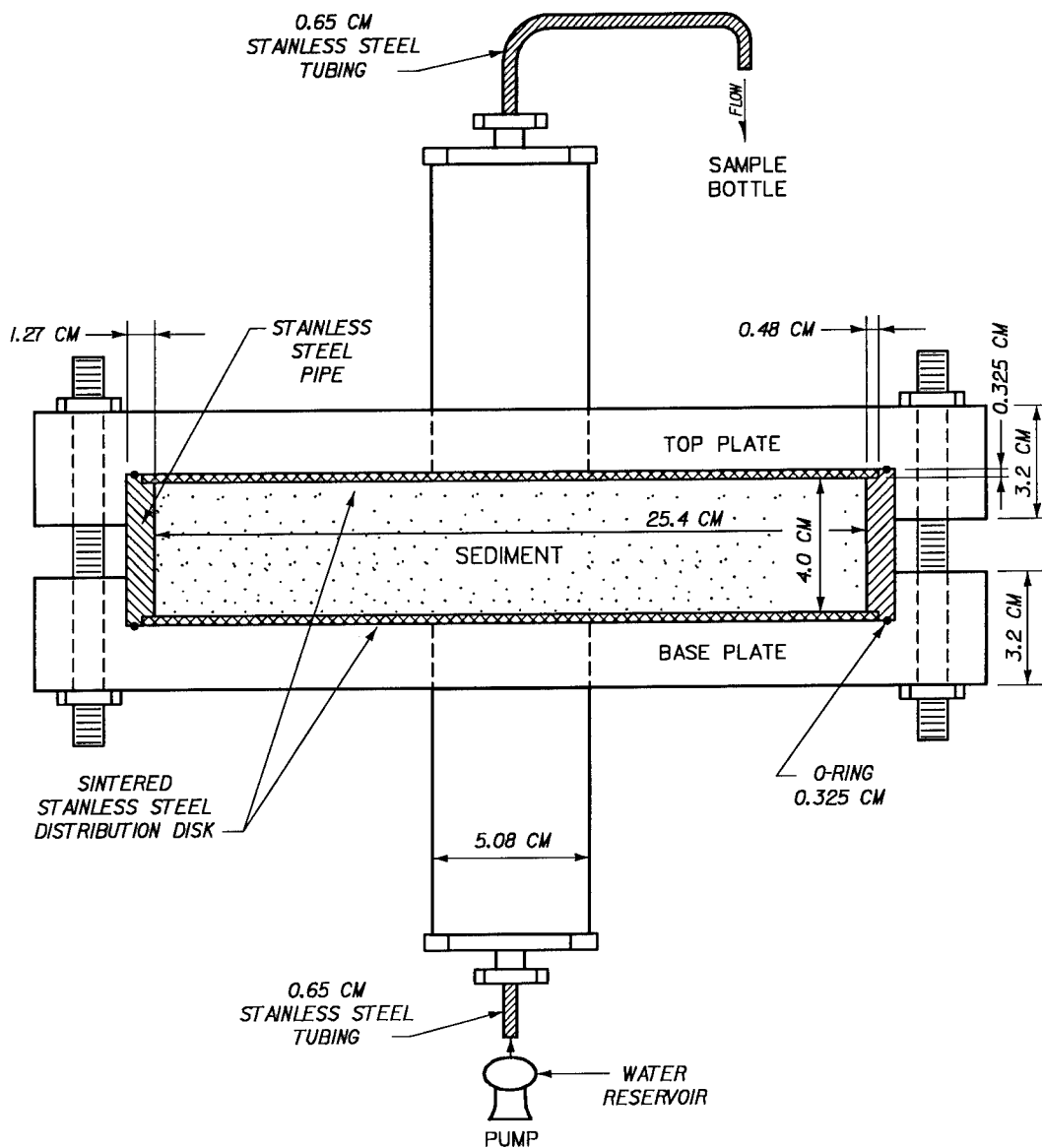

Figure 7. Schematic of improved column leaching apparatus for sediments and dredged material

As a single extraction, the TCLP does not provide information on the time-dependent characteristics of contaminant releases. In a CDF, leachate quality varies with time as infiltration percolates through the dredged material. The time dependency is not always one of decreasing contaminant concentration as percolating water removes contaminants. Studies have shown that when estuarine sediments are leached, changes in the pore-water ionic strength cause maximum concentrations of polychlorinated biphenyls to occur long after the initial pore volume of water has eluted (Myers and Brannon 1988).

WES-SBLT

The WES-SBLT provides quantitative information on the tendency to contaminants to move from dredged material solids to water under redox and pH conditions that are representative of CDFs. In addition, the WES-SBLT provides quantitative information on long-term elution trends. This type of information is needed to predict leachate quality in CDFs.

The desorption isotherm approach to interpreting WES-SBLT data assumes that the various processes responsible for interphase transfer can be represented by unique contaminant- and sediment-specific distribution coefficients for freshwater sediments and a set of contaminant- and sediment-specific distribution coefficients

INTERGRATED APPROACH FOR EXAMINING THE SOURCE TERM

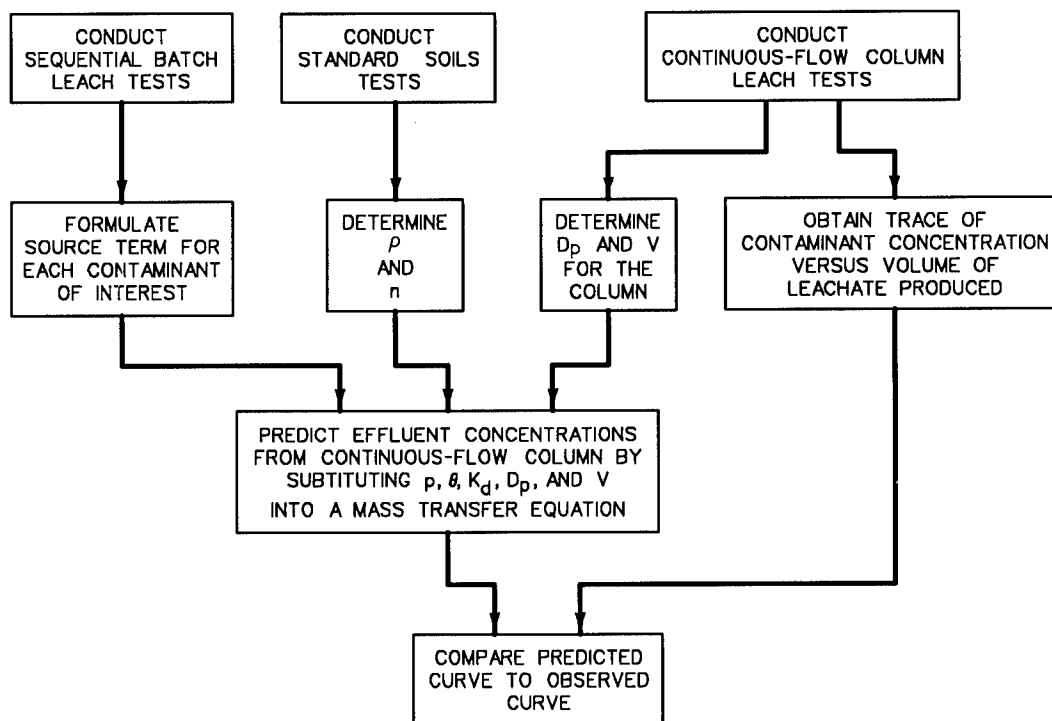

Figure 8. Schematic of integrated approach

for estuarine sediments. This approach seems to work, but has not been fully verified. Also, some aspects of the WES-SBLT, such as time required to reach steady-state leachate concentrations, are still under investigation.

Qualitative agreement between WES-SBLT elution trends and column elution trends has been obtained, but quantitative agreement is still lacking. In addition, there are no field data for verification of the WES-SBLT.

WES-Column

The WES-column leach test is less well-developed than the WES-SBLT, and additional work on column operation, sample collection and preservation, and mathematical modeling is needed before the integrated approach can be fully implemented. WES-column leach tests take several months to complete. Inspection and preservation of column leachates must be conducted on a daily basis for some contaminants. These requirements limit the usefulness of the WES-Column leach test beyond a research mode.

Summary

A thorough understanding of leachate generation in CDFs is necessary to judge the effectiveness of contaminant containment provided by these facilities. The integrated approach is being applied at the WES to provide the understanding needed for development of predictive techniques for leachate quality in CDFs.

Comparison of contaminant concentrations in the TCLP extract with concentration limits for the same is an approach best suited to regulation, not prediction. Although a waste may pass the TCLP, passing the TCLP provides no statutory release from liabilities associated with disposal (EPA 1990). The TCLP is best used as a hazardous waste regulatory tool, not a method for predicting contaminant mobility in dredged material.

When the objective is to predict leaching in a field setting, test conditions must be maintained that do not significantly alter chemical or physical parameters. Intentional adjustments in pH, redox, and ionic strength that yield artificial conditions should be avoided. For these reasons, the WES-SBLT is the most appropriate batch leach test available for developing the leach data needed for design of engineering controls. Until the WES-SBLT is fully developed, column leach testing and application of the integrated approach are recommended.

References

Brannon, J. M., Gunnison, D., Butler, P. L. and Smith, I., Jr. 1978. "Mechanisms That Regulate the Intensity of Oxidation-Reduction in Anaerobic Sediments and Natural Water Systems," Technical Report Y-78-11, US Army Engineer Waterways Experiment Station, Vicksburg, MS.

Brannon, J. M., Myers, T. E., Gunnison, D., and Price, C. B. 1991. "Non-Constant PCB Partitioning in New Bedford Harbor Sediment during Sequential Batch Leaching," *Environmental Science and Technology*, Vol 45, No 6, pp 1082-1087.

DiToro, D. M. 1985. "A Particle Interaction Model of Reversible Organic Chemical Sorption," *Chemosphere*, Vol 14, pp 1503-1538.

Environmental Laboratory. 1987. "Disposal Alternatives for PCB-Contaminated Sediments from Indiana Harbor, Indiana," Miscellaneous Paper EL-87-9, Vols I and II, US Army Engineer Waterways Experiment Station, Vicksburg, MS.

Francingues, N. R., Jr., Palermo, M. R., Lee, C. R., and Peddicord, R. K. 1985. "Management Strategy for Disposal of Dredged Material: Contaminant Testing and Controls," Miscellaneous Paper D-85-1, US Army Engineer Waterways Experiment Station, Vicksburg, MS.

Gambrell, R. P., Khalid, R. A., and Patrick, W. H., Jr. 1978. "Disposal Alternatives for Contaminated Dredged Material as a Management Tool to Minimize Adverse Environmental Effects," Technical Report DS-78-8, US Army Engineer Waterways Experiment Station, Vicksburg, MS.

Gschwend, P. M, and Wu, S. 1985. "On the Constancy of Sediment-Water Partition Coefficients of Hydrophobic Organic Pollutants," *Environmental Science and Technology*, Vol 19, No. 1, pp 90-96.

Louisiana Water Resources Research Institute. 1990. "Synopsis of Research Needs Workshop: Development of Leach Tests for Contaminated Dredged Material," Miscellaneous Paper D-90-3, US Army Engineer Waterways Experiment Station, Vicksburg, MS.

Myers, T. E., and Brannon, J. M. 1988. "New Bedford Harbor Superfund Project, Acushnet River Estuary Engineering Feasibility Study; Report 5, Evaluation of Leachate Quality," Technical Report EL-88-15, US Army Engineer Waterways Experiment Station, Vicksburg, MS.

Myers, T. E., Tittlebaum, M. E., and Gambrell, R. P. 1991. "Design of an Improved Column Leaching Apparatus for Sediments and Dredged Material," Miscellaneous Paper D-91-3, US Army Engineer Waterways Experiment Station, Vicksburg, MS.

O'Connor, D. J., and Connolly, J. P. 1980. "The Effect of Concentration of Adsorbing Solids on the Partition Coefficient," *Water Research*, Vol 14, pp 1517-1523.

Palermo, M. R., Shafer, R. A., Brannon, J. M., Myers, T. E., Truit, C. L., Zappi, M. E., Skogerboe, J. G., Sturgis, T. C., Wade, R., Gunnison, D., Griffin, D. M., Jr., Tatum, H., Portzer, S., and Adamec, S. A. 1989. "Evaluation of Dredged Material Disposal Alternatives for US Navy Homeport at Everett, Washington," Technical Report EL-89-1, US Army Engineer Waterways Experiment Station, Vicksburg, MS.

Patrick, W. H., Jr., and Mikkelsen, D. S. 1971. "Plant Nutrient Behavior in Flooded Soil," *Fertilizer Technology and Use*, Soil Science Society of America, Madison, WI.

Ponnamperuma, F. N. 1972. "The Chemistry of Submerged Soils," *Advances in Agronomy*, Vol 24, pp 29-88.

Stumm, W., and Morgan, J. J. 1981. *Aquatic Chemistry*, John Wiley & Sons, New York.

US Environmental Protection Agency. 1990. "Hazardous Waste Management System; Identification and Listing of Hazardous Waste; Toxicity Characteristics Revisions," *Federal Register*, Vol 55, No. 61, pp 11,798-11,877.

Voice, T. C., Rice, C. P., and Weber, W. J., Jr. 1983. "Effect of Solids Concentration on the Sorptive Partitioning of Hydrophobic Pollutants in Aquatic Systems," *Environmental Science and Technology*, Vol 17, No. 9, pp 513-518.