

# NAVAL POSTGRADUATE SCHOOL MONTEREY, CALIFORNIA



~~19950403 100~~

## THESIS



**EXPERIMENTAL INVESTIGATION OF THE  
EFFECTIVENESS OF FLOW-THROUGH  
MODULES FOR ELECTRONICS COOLING**

by

William G. Plott

December 1994

Thesis Advisor:

M. D. Kelleher

Approved for public release; distribution is unlimited.

19950404 086

19950404 086

# REPORT DOCUMENTATION PAGE

Form Approved OMB No. 0704-0188

Public reporting burden for this collection of information is estimated to average 1 hour per response, including the time for reviewing instruction, searching existing data sources, gathering and maintaining the data needed, and completing and reviewing the collection of information. Send comments regarding this burden estimate or any other aspect of this collection of information, including suggestions for reducing this burden, to Washington Headquarters Services, Directorate for Information Operations and Reports, 1215 Jefferson Davis Highway, Suite 1204, Arlington, VA 22202-4302, and to the Office of Management and Budget, Paperwork Reduction Project (0704-0188) Washington DC 20503.

1. AGENCY USE ONLY <i>(Leave blank)</i>	2. REPORT DATE December 1994	3. REPORT TYPE AND DATES COVERED Master's Thesis
---	---------------------------------	---

4. TITLE AND SUBTITLE Experimental Investigation of the Effectiveness of Flow-Through Modules for Electronics Cooling	5. FUNDING NUMBERS
--	--------------------

6. AUTHOR(S) William G. Plott

7. PERFORMING ORGANIZATION NAME(S) AND ADDRESS(ES)  
Naval Postgraduate School  
Monterey CA 93943-5000

8. PERFORMING ORGANIZATION REPORT NUMBER

9. SPONSORING/MONITORING AGENCY NAME(S) AND ADDRESS(ES)

10. SPONSORING/MONITORING AGENCY REPORT NUMBER

11. SUPPLEMENTARY NOTES The views expressed in this thesis are those of the author and do not reflect the official policy or position of the Department of Defense or the U.S. Government.

12a. DISTRIBUTION/AVAILABILITY STATEMENT  
Approved for public release; distribution is unlimited.

12b. DISTRIBUTION CODE

13. ABSTRACT *(maximum 200 words)*

The heat transfer characteristics and performance capabilities of a liquid flow-through module for electronics cooling were investigated experimentally using the Standard Electronics Module, format "E" (SEM-E) size module. Brayco Micronic 889, a dielectric polyalphaolefin, was tested as the coolant. One surface of the flow-through module was populated with six etched foil heaters placed on the module over the fluid flow path. With thermocouples affixed to the surface and placed in the inlet and outlet tubing, data was gathered and analyzed to quantify module effectiveness in dissipating heat over a variety of power input settings and coolant flow rates.

14. SUBJECT TERMS Liquid flow-through modules

15. NUMBER OF PAGES 118

16. PRICE CODE

17. SECURITY CLASSIFICATION OF REPORT  
Unclassified

18. SECURITY CLASSIFICATION OF THIS PAGE  
Unclassified

19. SECURITY CLASSIFICATION OF ABSTRACT  
Unclassified

20. LIMITATION OF ABSTRACT  
UL



Approved for public release; distribution is unlimited.

**EXPERIMENTAL INVESTIGATION OF THE EFFECTIVENESS OF  
FLOW-THROUGH MODULES FOR ELECTRONICS COOLING**

by

William G. Plott  
Lieutenant, United States Navy  
B.S., United States Naval Academy, 1988

Submitted in partial fulfillment  
of the requirements for the degree of

**MASTER OF SCIENCE IN MECHANICAL ENGINEERING**

from the

**NAVAL POSTGRADUATE SCHOOL  
December 1994**

Author:



William G. Plott

Approved by:



Matthew D. Kelleher, Thesis Advisor



Matthew D. Kelleher, Chairman  
Department of Mechanical Engineering



## ABSTRACT

The heat transfer characteristics and performance capabilities of a liquid flow-through module for electronics cooling were investigated experimentally using the Standard Electronics Module, format "E" (SEM-E) size module. Brayco Micronic 889, a dielectric polyalphaolefin, was tested as the coolant. One surface of the flow-through module was populated with six etched foil heaters placed on the module over the fluid flow path. With thermocouples affixed to the surface and placed in the inlet and outlet tubing, data was gathered and analyzed to quantify module effectiveness in dissipating heat over a variety of power input settings and coolant flow rates.

Accession For	
NTIS	<input checked="" type="checkbox"/>
CRA&I	<input type="checkbox"/>
DTIC	<input type="checkbox"/>
TAB	<input type="checkbox"/>
Unannounced	<input type="checkbox"/>
Justification	.....
By .....	
Distribution /	
Availability Codes	
Dist	Avail and/or Special
A-1	



## TABLE OF CONTENTS

I.	INTRODUCTION . . . . .	1
A.	ELECTRONICS COOLING . . . . .	1
1.	Liquid Cooling . . . . .	2
2.	Finned Heat Exchangers . . . . .	2
3.	Flow-Through Modules . . . . .	3
B.	OBJECTIVES . . . . .	4
II.	EXPERIMENTAL APPARATUS . . . . .	9
A.	SUPPORT SYSTEM ASSEMBLY . . . . .	9
1.	Fluid Circulation System . . . . .	9
2.	Power Distribution System . . . . .	10
3.	Data Acquisition System . . . . .	11
B.	TEST SECTION ASSEMBLY . . . . .	12
1.	Module Housing . . . . .	12
2.	Instrumentation . . . . .	12
III.	EXPERIMENTAL PROCEDURES . . . . .	19
A.	DATA COLLECTION . . . . .	19
B.	DATA ANALYSIS . . . . .	20
1.	Calculation of Coolant Thermophysical Properties . . . . .	21
a.	Density (g/ml) . . . . .	21
b.	Specific Heat $C_p$ (J/g°C) . . . . .	21
2.	Calculation of Heat Dissipation . . . . .	22
a.	Temperature Differential . . . . .	22
b.	Heat Dissipated by the Coolant $Q_f$ (W) . . . . .	22
c.	Heat Losses Through the Insulation $Q_{ins}$ (W) . . . . .	22
3.	Calculation of Power into the Heaters $P_h$ (W) . . . . .	23

IV. RESULTS . . . . .	25
A. RAW TEMPERATURE DATA . . . . .	25
B. HEAT TRANSFER DATA . . . . .	25
V. DISCUSSION AND CONCLUSIONS . . . . .	81
A. TEMPERATURE PATTERNS . . . . .	81
B. HEAT TRANSFER CALCULATIONS . . . . .	83
VI. RECOMMENDATIONS . . . . .	87
APPENDIX A. SAMPLE CALCULATIONS . . . . .	89
APPENDIX B. UNCERTAINTY CALCULATIONS . . . . .	91
LIST OF REFERENCES . . . . .	97
INITIAL DISTRIBUTION LIST . . . . .	99

LIST OF FIGURES

Figure 1. Offset plate fins (from Herold, Srindar, and Hu, 1992) . . . . . 5

Figure 2. Flow-through module (SEM-E size) . . . . . 6

Figure 3. Fluid flow path within FTM (from Buechler and Brough, 1993) . . . . . 7

Figure 4. Diagram of experimental setup . . . . . 15

Figure 5. FTM with heaters affixed and brass fittings inserted . . . . . 16

Figure 6. Heater and thermocouple locations . . . . . 17

Figure 7. Module surface temperatures at power setting 1 . . . . . 37

Figure 8. Module surface temperatures at power setting 2 . . . . . 38

Figure 9. Module surface temperatures at power setting 3 . . . . . 39

Figure 10. Module surface temperatures at power setting 4 . . . . . 40

Figure 11. Module surface temperatures at power setting 5 . . . . . 41

Figure 12. Module surface temperatures at power setting 6 . . . . . 42

Figure 13. Module surface temperatures at power setting 7 .....	43
Figure 14. Module surface temperatures at power setting 8 .....	44
Figure 15. Module surface temperatures at power setting 9 .....	45
Figure 16. Module surface temperatures at power setting 10 .....	46
Figure 17. Coolant temperature increase through FTM . . .	47
Figure 18. Log-log plot of temperature differentials . . .	48
Figure 19. Heat absorbed by fluid ( $Q_f$ ) . . . . .	59
Figure 20. Revised $Q_f$ calculations based on lab data .....	60
Figure 21. Temp rise across heaters at power setting 1 .....	61
Figure 22. Temp rise across heaters at power setting 2 .....	62
Figure 23. Temp rise across heaters at power setting 3 .....	63
Figure 24. Temp rise across heaters at power setting 4 .....	64

Figure 25. Temp rise across heaters at power setting 5 .....	65
Figure 26. Temp rise across heaters at power setting 6 .....	66
Figure 27. Temp rise across heaters at power setting 7 .....	67
Figure 28. Temp rise across heaters at power setting 8 .....	68
Figure 29. Temp rise across heaters at power setting 9 .....	69
Figure 30. Temp rise across heaters at power setting 10 .....	70
Figure 31. Mid-channel temp drops at power setting 1 . .	71
Figure 32. Mid-channel temp drops at power setting 2 . .	72
Figure 33. Mid-channel temp drops at power setting 3 . .	73
Figure 34. Mid-channel temp drops at power setting 4 . .	74
Figure 35. Mid-channel temp drops at power setting 5 . .	75
Figure 36. Mid-channel temp drops at power setting 6 . .	76
Figure 37. Mid-channel temp drops at power setting 7 . .	77
Figure 38. Mid-channel temp drops at power setting 8 . .	78

Figure 39. Mid-channel temp drops at power setting 9 . .	79
Figure 40. Mid-channel temp drops at power setting 10 .	80
Figure 41. TableCurve polynomial fit of flowmeter calibration data . . . . .	95
Figure 42. Comparison of specific heat values . . . . .	96

LIST OF TABLES

Table 1. Power settings for experiments . . . . . 20

Table 2. Brayco Micronic 889 density (Castrol, 1994) . . 21

Table 3. Brayco Micronic 889 specific heat (Castrol, 1994)  
. . . . . 22

Table 4. Power and temperature data at power setting 1  
. . . . . 27

Table 5. Power and temperature data at power setting 2  
. . . . . 28

Table 6. Power and temperature data at power setting 3  
. . . . . 29

Table 7. Power and temperature data at power setting 4  
. . . . . 30

Table 8. Power and temperature data at power setting 5  
. . . . . 31

Table 9. Power and temperature data at power setting 6  
. . . . . 32

Table 10. Power and temperature data at power setting 7  
. . . . . 33

Table 11. Power and temperature data at power setting 8  
. . . . . 34

Table 12. Power and temperature data at power setting 9 . . . . .	35
Table 13. Power and temperature data at power setting 10 . . . . .	36
Table 14. Calculations for power setting 1 . . . . .	49
Table 15. Calculations for power setting 2 . . . . .	50
Table 16. Calculations for power setting 3 . . . . .	51
Table 17. Calculations for power setting 4 . . . . .	52
Table 18. Calculations for power setting 5 . . . . .	53
Table 19. Calculations for power setting 6 . . . . .	54
Table 20. Calculations for power setting 7 . . . . .	55
Table 21. Calculations for power setting 8 . . . . .	56
Table 22. Calculations for power setting 9 . . . . .	57
Table 23. Calculations for power setting 10 . . . . .	58
Table 24. Calculation of $\Delta T_{avg}$ . . . . .	90
Table 25. Uncertainties in variables . . . . .	91

Table 26. Flowmeter calibration with estimated uncertainty  
..... 94

Table 27. Calibration of inlet and outlet thermocouples  
..... 94



## ACKNOWLEDGEMENT

The author extends special thanks to the following for aiding in bringing this project to its completion:

- To Naval Surface Warfare Center in Crane, IN for the financial support and technical information that enabled the research to occur.
- To Professor Kelleher, whose patience and wisdom wrought through experience were essential in smoothing out difficulties.
- To Jim Scholfield and Tom Christian, who consistently guided me through the experimental process with much time-saving assistance.
- To Glen Kerol, who stepped in beyond the call of duty to ensure emergent supply needs were expedited.
- To LT Carlos Suarez, who was always willing to take time out from his own work to give assistance when the need arose.
- To LCDR Mark and Lisa Whitney, true friends who volunteered to help out in the typing and formatting of this document.
- And finally, thanks to my God for placing me here and sustaining me through the ups and downs of life these past 27 months.



## I. INTRODUCTION

### A. ELECTRONICS COOLING

Modern advances in microelectronic technology have steadily increased the heat dissipation levels of integrated circuit chips and mandate improved thermal management techniques. Heat fluxes at the surface of a chip may reach  $200 \text{ W/cm}^2$  and as efforts to miniaturize electronics continue even greater fluxes are expected. Equipment reliability becomes a major concern as components are subjected to higher temperatures. One study showed that temperature fluctuations greater than  $20^\circ\text{C}$  about an average temperature resulted in increasing the failure rate eightfold (Hilbert and Kube, 1969). Failure may result from thermal fracture of the usually ceramic or metallic substrate, plastic flow of printed circuits, etc., due to elevated temperatures, even without the presence of such fluctuations. In order to hold failure rates in the vicinity of 0.5 to 2.0% per thousand hours of operation, component junction temperatures of over  $100^\circ\text{C}$  have been commonly accepted in the past, yet by further decreasing temperatures, one can increase expected life and decrease maintenance costs as well as associated down time. (Kraus and Bar-Cohen, 1983).

Natural convection and radiation cooling relying upon the ambient air is insufficient to deal with the rapidly increasing fluxes. Space limitations, which often discourage the use of conventional forced convection air cooling, provide an impetus to the development of alternative methods of cooling. Better thermal performance can also pave the way for weight savings as the density of circuitry might be allowed to increase without increasing component housing dimensions. Such improvements have readily visible advantages for ship and aircraft design where space is at a premium.

Much research is currently underway in the field of electronics cooling as attempts are made to address these many

concerns, with the need to bring a capable cooling medium closer to the critical components at its focus. This study focuses on the use of liquid flow-through modules and their effectiveness in heat removal using a polyalphaolefin coolant.

### **1. Liquid Cooling**

Natural convection cooling in air is effective for only relatively small heat fluxes, yet forced convection air cooling can only increase heat dissipation to the vicinity of  $1 \text{ W/cm}^2$  if allowing a  $100^\circ\text{C}$  temperature difference (Kraus and Bar-Cohen, 1983). Liquid cooling has thus emerged as an attractive alternative method of cooling with direct immersion and conduction cooling at the center of much research. Because of the greater heat transfer coefficients associated with liquids, their use in cooling allows for lengthier emergency operation of vital equipment in the event of interrupted flow. Some disadvantages do exist with liquid cooling, such as the added system weight and additional costs associated with the fluid flow system. There may also be the potential for damage to electronic components due to system leaks. Lightweight dielectric coolants, such as the Brayco Micronic 889 used in this study, are therefore promising solutions to the thermal challenges confronted in the design of electronics cooling systems. Brayco Micronic 889 is a polyalphaolefin made for use in closed loop systems for ground based and airborne electronics cooling. It lays claim to high specific heats and to compatibility with typical construction metals. (Castrol, 1994).

### **2. Finned Heat Exchangers**

Extended surfaces, or fins, have become a commonplace aid in convective heat transfer. Though abundant research has sought to improve convective heat transfer effects using fins, most past studies have dealt with the use of air and other

gases. The usefulness of such data is very limited when evaluating the performance of liquid coolants. Because of the higher Prandtl numbers and thermal conductivities generally associated with liquid coolants, the methods of enhancing heat transfer are slightly different than those methods used with gases. The differences between liquids and gases in the behavior of properties such as density and specific heat also necessitate additional research. With liquids, rather than simply increasing the "wetted" surface area through branching mazes of fins and narrowing the resultant channels, the convection coefficient may best be elevated by the interruption of the developing thermal boundary layers. Heat exchangers such as the flow-through module use offset plate fins, similar to those shown in Figure 1, to enhance heat transfer through the periodic starting and development of laminar thermal boundary layers over flow channels formed by the fins and their dissipation in the fin wakes. This flow is also coupled with an increase in the pressure drop due to the friction and form drag associated with the fins.

### **3. Flow-Through Modules**

Offset plate fins are the core of the design of a liquid Flow-Through Module (FTM) such as the Standard Electronics Module, Format E (SEM-E) size module. Flow-through modules are manufactured through vacuum brazing, which allows for the creation of very narrow channels and fins in a thin module. The module tested is 0.100 inches thick, with an 0.02 inch Aluminum 6061 faceplate. The fins within the module are made from an Aluminum 3003 alloy and are 0.06 inches in height, 0.125 inches long, and a mere 0.006 inches thick. The fin density is twenty fins per inch. (Buechler and Brough, 1993).

Electronic components placed on the surface of a module are cooled by the coolant flowing within the module. Both surfaces of the module could be used in this manner with the

added benefit of the structural support to the circuitry provided by the plate. The thin module structure is very suitable for stacking. Several modules can be housed in a small enclosure with rails to guide insertion and maintain some separation. The module manufacturing process allows for the internal directing of coolant to areas of particular thermal concern on the surface through the flexibility of flow path design. The FTM tested, shown in Figure 2, possesses three main flow paths filled with fins which channel the coolant along a winding path from entrance to exit (Figure 3). The flow-through module is currently under evaluation by the military for increased application.

#### **B. OBJECTIVES**

This study examined the effectiveness of the SEM-E sized flow-through module using a synthetic dielectric polyalphaolefin coolant known as Brayco Micronic 889, manufactured by Castrol. Several different flow rates were utilized while varying the heat flux supplied to the surface by etched foil heaters. Temperature data for the module surface was collected in order to quantify the effectiveness of the module and provide the groundwork for potential further studies into the analytical modelling of the convection process occurring within the module. Data on inlet and outlet temperatures was also collected for analysis of the heat dissipation capabilities of the module over a variety of power inputs and flow levels.

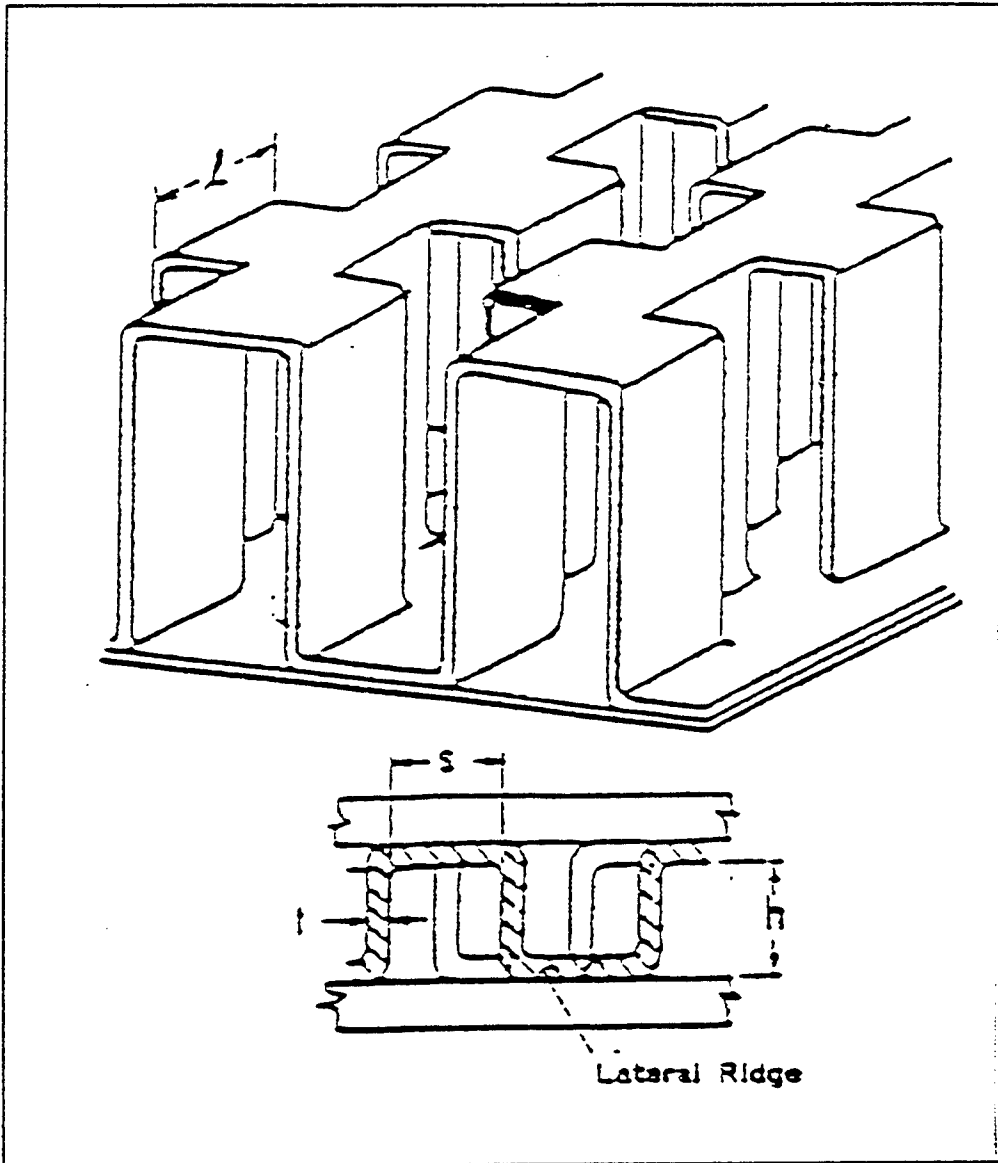

Figure 1. Offset plate fins (from Herold, Srindar, and Hu, 1992).

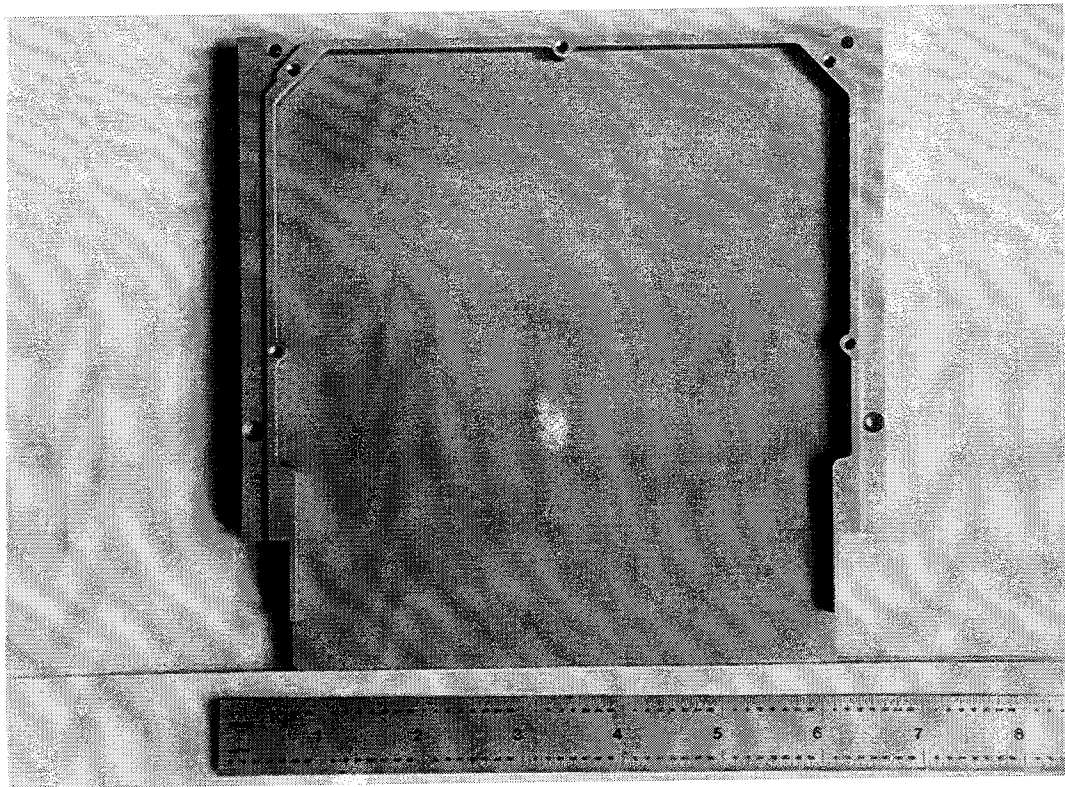
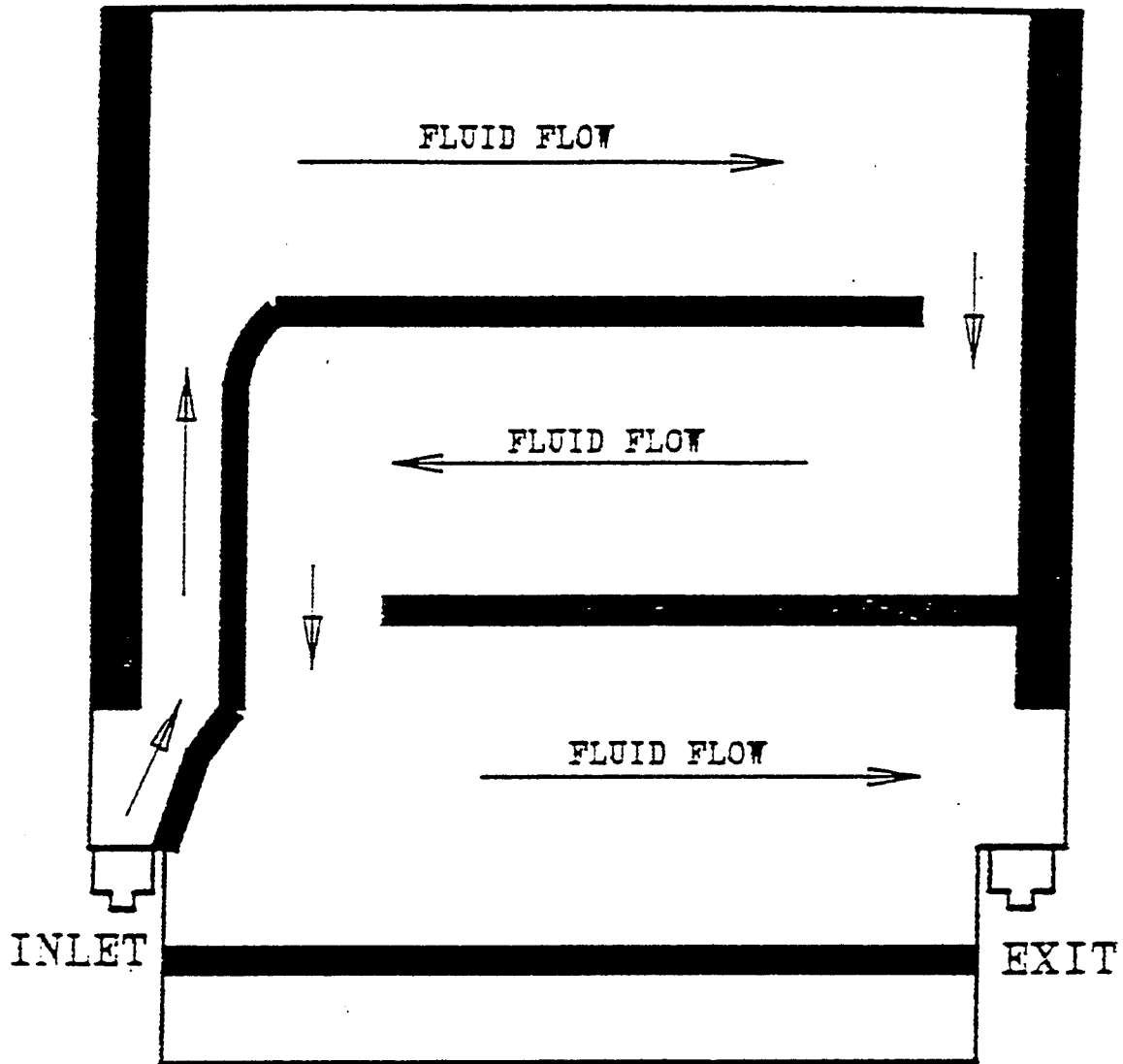

Figure 2. Flow-through module (SEM-E size).



Module Thickness: 0.1 inch  
Faceplate Thickness: 0.02 inch  
Faceplate Material: 6061 Alum.

Figure 3. Fluid flow path within FTM (from Buechler and Brough, 1993).



## II. EXPERIMENTAL APPARATUS

### A. SUPPORT SYSTEM ASSEMBLY

The experimental apparatus consisted of the flow-through module assembly and the support system as drawn in Figure 4. A description of each sub-system and its components follows.

#### 1. Fluid Circulation System

An Endocal RTE-5 refrigerated circulating bath provided the heat sink for the coolant, reducing its temperature to approximately ambient room temperature prior to entering the pump. The pump was a Masterflex variable speed drive with an attached pump head, providing a flow of up to one liter per minute through flexible Tygon tubing. A Fischer and Porter flow meter was used to determine the flow rate. Calibration was accomplished by timing the collection of a volume of coolant over several meter readings. The maximum uncertainty in the measured flow in the range of testing was 2.8%. Calibration data was then fitted to a fifth order polynomial using TableCurve software. The polynomial was used to determine flowmeter settings for a desired rate of flow during experiments. Appendix B includes flow meter uncertainty calculations and the polynomial curve fit.

Brass tubing was threaded to fit the inlet and exit ports of the module in order to provide an attachment point for tubing. The brass tubes were inserted into the Tygon tubing and clamps were slipped over the connection and tightened. Inlet and exit tubing was fed into Teflon T-fittings, each of which was modified to accommodate a thermocouple. Upon exiting the module and passing through the T-fitting, the coolant returned to the refrigerated bath. Interconnections between components were made with plastic and Tygon tubing and sealed with an acrylic adhesive. Clamps were affixed to connections to maintain system integrity at high pressures.

## 2. Power Distribution System

Power to the heaters was supplied by a Hewlett Packard 0-20 V, 0-10 A DC power supply. The six heaters, wired in parallel, were 7.6 mm (0.3 inch) by 38.1 mm (1.5 inches) Minco Kapton etched foil heaters. Two heaters were applied with thermally conductive epoxy adhesive (Omegabond 101) along each of the three module flow channels at a spacing of 5 cm (2 inches). Flow channels were roughly determined by flow visualization utilizing a transparent polymer sheet of Hallcrest thermochromic liquid crystals. Each row of heaters was separated by 1.27 cm (0.5 inch). Each heater had an effective heated area of 1.94 cm<sup>2</sup> (0.3 in<sup>2</sup>) and a resistance of 20.7 ohms  $\pm$  10%. Figure 5 shows the actual module once heaters were attached. The side of the module to which heaters were affixed was arbitrarily designated as side "A."

Thermally stable precision resistors with resistances of 0.487 ohms  $\pm$  1% were connected in series with each heater. Each resistor was tested using a Rosemount 920A Commutating Bridge to establish its resistance (R) to a fourth decimal place.

An HP 3852A Data Acquisition/Control Unit with an HP 44701A digital voltmeter was used to determine voltages. The voltage drop across a precision resistors ( $V_r$ ) was first measured utilizing an HP 44705A multiplexer and then current to the heater was determined using:

$$I_h = \frac{V_r}{R} \quad (1)$$

Voltage was also measured across each heater using the HP 44705A multiplexer and HP 44701A voltmeter. Power supplied to each heater was calculated as:

$$P_h = V_h * I_h \quad (2)$$

### 3. Data Acquisition System

A personal computer fitted with a National Instruments GPIB-PCIIA IEEE-488 interface board was used to control an HP3852A Data Acquisition/Control Unit for measurement of voltages and temperatures. Data runs were performed utilizing a program in QBASIC. An HP 44708A 20 channel relay multiplexer for thermocouple compensation provided the interface between the HP 44701A voltmeter and the thermocouples for temperature readings. Fifteen thermocouples were on the module itself. In addition one thermocouple was in the inlet and one was in the outlet tubing. Two thermocouples were in the insulation layers above the module to estimate heat loss. An additional thermocouple was on the surface of the outer layer of insulation, thus utilizing all twenty channels of the multiplexer. Figure 6 shows a layout of the thermocouple locations as well as the heater locations. Thermocouples adjacent to the heaters were placed as close to the heaters as possible, while the other module thermocouples were placed midway between the heaters.

Thermocouple extensions were fed into channel numbers 0 through 19 of the HP 44708A in the data acquisition system. Heater voltages were measured by channels 0 through 5, which corresponded to heaters A through F respectively. Precision resistor voltages were measured utilizing channels 6 through 11 of the HP 44705A relay multiplexer.

## **B. TEST SECTION ASSEMBLY**

### **1. Module Housing**

A plexiglass enclosure was made to support the FTM and insulation in a horizontal position, thus preventing natural convection effects which might occur in an upright or inclined system. The sides of the structure were made from 0.5 inch (1.25 cm) thick plexiglass and the back was made from 0.125 inch (0.32 cm) thick plexiglass. The module and insulation rested upon a horizontal 0.25 inch (0.64 cm) plexiglass piece which was secured to the sides by screws. Insulation was one layer of 0.75 inch (1.91 cm) black foam insulation below and two layers above the module with a layer of insulation along the sides and back of the module as well. The enclosure of the module was open in the front to allow for protruding wiring and tubing.

### **2. Instrumentation**

Copper-constantan (T-type) thermocouples were affixed to the upper surface of the module as viewed in the housing. Flat, 5 mil thick, foil type, cement-on thermocouples were used to allow placement very close to the heaters. Thermocouple leads were separated using Kapton tape. Copper leads were soldered to thermocouple extension wire and the constantan leads were resistance welded to the extension wire. These connections were also wrapped in Kapton tape to guarantee their separation. Thermally conductive paste was applied to the thermocouple junction at the application point to minimize any air resistance and Kapton tape was placed over each thermocouple to prevent dislocation.

Coolant temperature was measured using T-type thermocouple probes in the inlet and outlet tubing from the module. The probes were made from 8 mil thermocouple wiring arc welded to form a "bead" junction. The probes were fed

through a small hole drilled in a plastic slug and inserted into a Teflon T-fitting. The beads were just below the center of the flow path in order to achieve a more "average" value for fluid temperature. Small wire screen filters were made for the T-fittings to prevent any small particles from entering the flow. One filter was designed to rest on the inner shoulder of the T-fitting, upstream of the inlet thermocouple probe. A filter was placed upstream of the thermocouple probe in the outlet T-fitting in a similar fashion in order to promote fluid mixing prior to the thermocouple measurement.

Thermocouples placed above the module for determining losses through the insulation were made from 24 gage copper-constantan extension wire arc welded to form bead junctions. These thermocouples were placed along an imaginary vertical line extending above thermocouple 13 as shown in Figure 6. This allowed for a direct flow path to be examined for estimating conduction losses through the insulation. Electrical tape was used to hold the thermocouples in place on the insulation.

All thermocouples were initially calibrated in an ice bath prepared from distilled water. Using the data collection system, no thermocouple reading differed by more than  $0.11^{\circ}\text{C}$  from  $0.0^{\circ}\text{C}$  when placed in the ice bath. Because of the desire for the highest level of accuracy in the determination of fluxes, the inlet and outlet thermocouples were additionally calibrated using a Rosemount 920A commutating bridge and a constant temperature ethylene glycol bath. Both thermocouples were placed in the bath and tandem readings collected over a temperature range of  $17^{\circ}\text{C}$  to  $46^{\circ}\text{C}$ . These values were compared with the reference value obtained from a platinum resistance thermometer also in the bath. The results indicated that the the two thermocouples produced readings within  $0.03^{\circ}\text{C}$  of each other, although they varied by as much as  $0.13^{\circ}\text{C}$  from the

reference. Table 26 in Appendix B shows the readings collected during calibration. These figures are used in determining overall uncertainty as discussed in Appendix B.

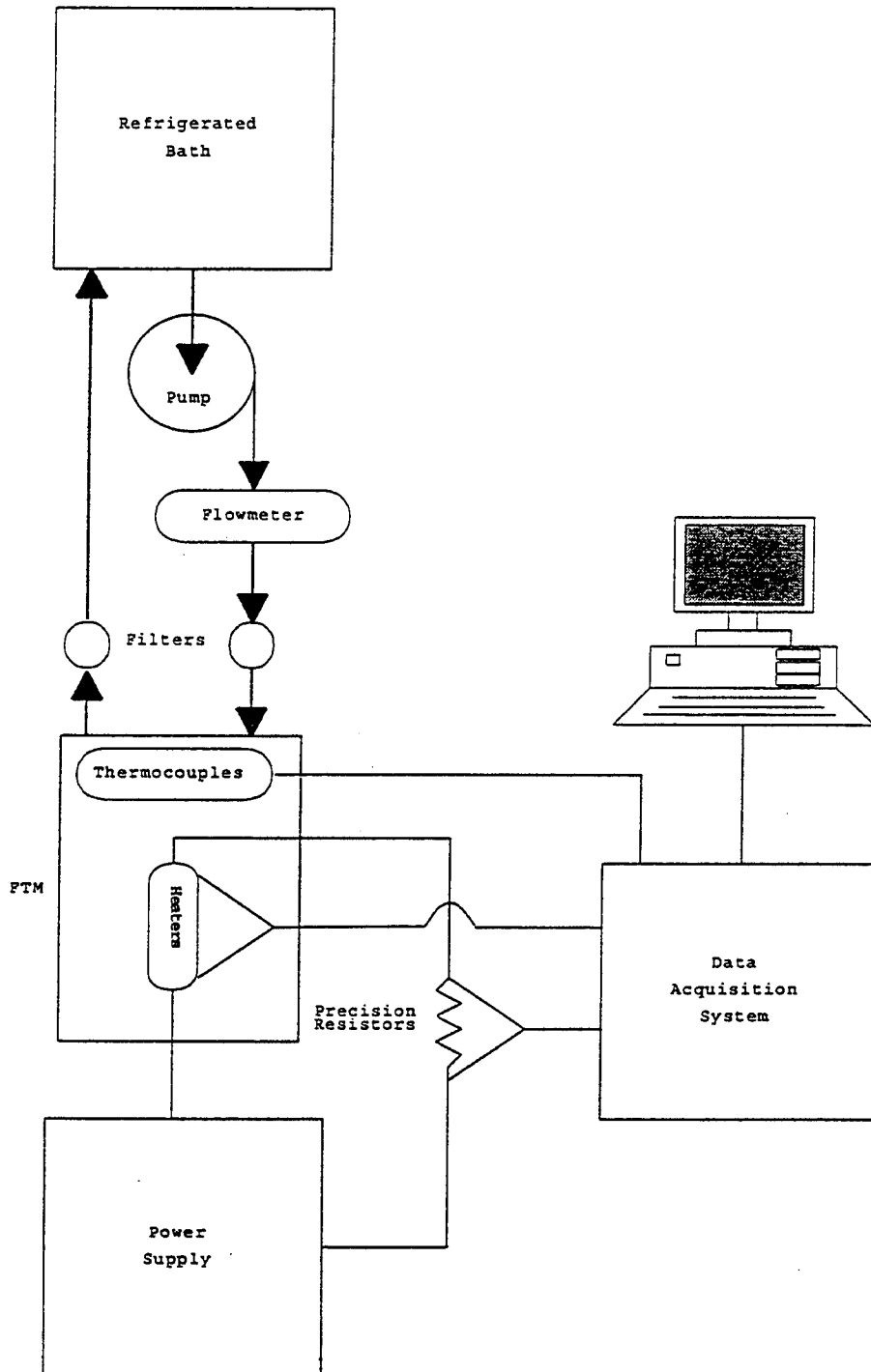
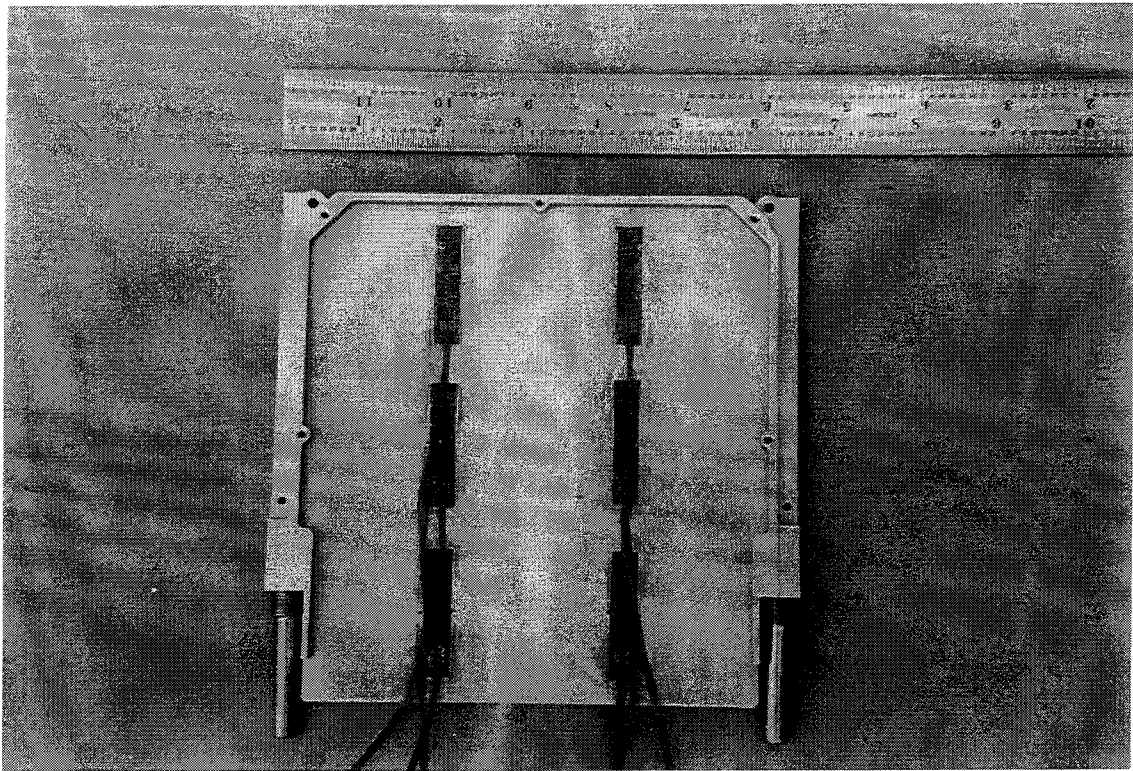
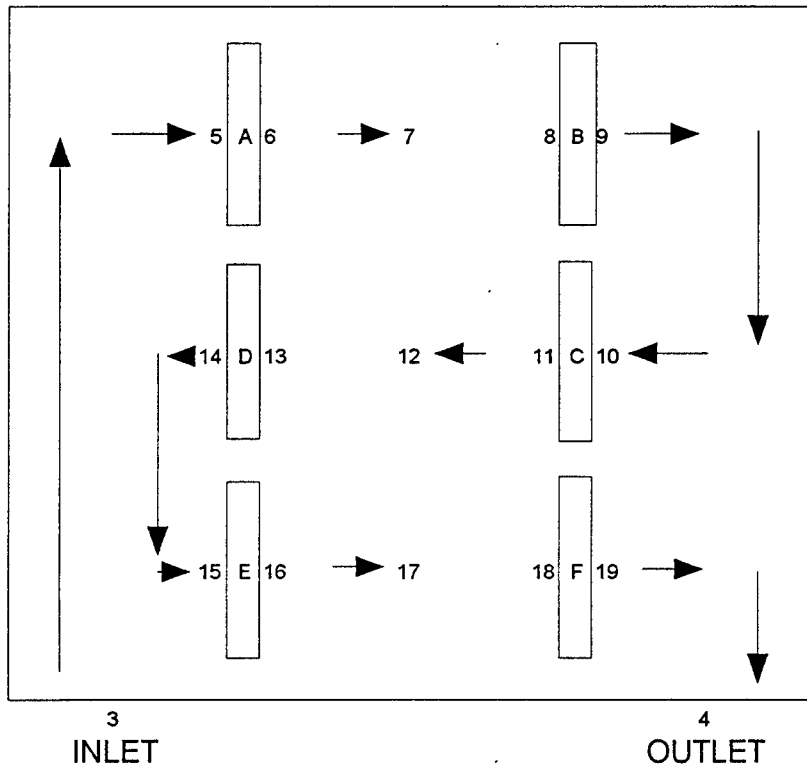

Figure 4. Diagram of experimental setup.



**Figure 5.** FTM with heaters affixed and brass fittings inserted.

### Flow-Through Module Side A



Heater locations are indicated by lettered rectangles.  
 Spacing is approximately 2" (5 cm) horizontally and 0.5" (1.25 cm) vertically.  
 Thermocouple locations are indicated by numbers.  
 Thermocouples 7, 12, and 17 are approximately 1" (2.5 cm) from adjacent heaters.

#### CROSS SECTIONAL VIEW

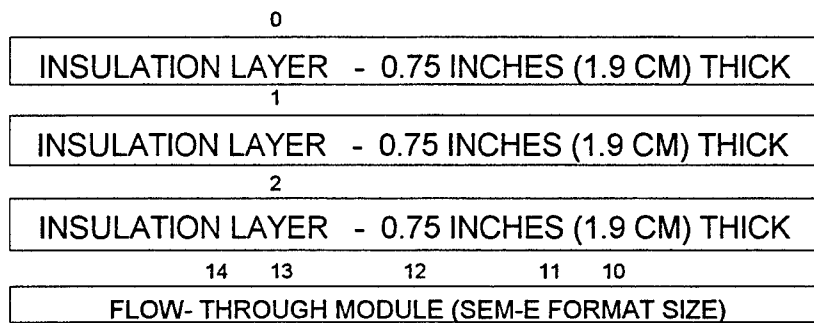

**Figure 6.** Heater and thermocouple locations.



### III. EXPERIMENTAL PROCEDURES

#### A. DATA COLLECTION

Prior to conducting any experimental runs, the data collection program was run to determine the approximate ambient room temperature. In order to prepare for data collection, the refrigerated bath was started and the pump was adjusted to a coolant flow level of 1000 ml/min. Bath temperature was adjusted to the ambient temperature. The power supply was then energized and tuned to the appropriate setting by running the data collection program and adjusting the voltage and current settings. Power settings are shown in Table 1. Because of variations in resistances for each heater-precision resistor loop, each heater varied in its power dissipation. Thus the power setting was based on the total power ( $P_{\text{total}}$ ) input. Heater flux was determined as:

$$q'' = \frac{\left(\frac{P_{\text{total}}}{6}\right)}{1.94} \quad (3)$$

where 1.94 cm<sup>2</sup> is the effective heater area.

Temperature data was monitored to determine when steady state had been achieved. Steady state was assumed when thermocouple readings on the surface and above the module fluctuated less than 0.15°C over a one minute interval. Once at steady state, data was recorded and saved. Data recorded by the system included thermocouple temperatures and voltage readings as well as a series of 60 coolant inlet and outlet temperature readings over a period of approximately 25 seconds. The flow rate was then adjusted to begin the next run.

Once power and flow rates were set, steady state could be reached in four to thirty minutes, depending upon the power setting and flow rate. In general, steady state was most

rapidly achieved at higher flow rates. Flow rates were decreased in 100 ml/min increments from 1000 ml/min to 300 ml/min. This procedure seemed to allow steady state to be reached more quickly, particularly in the insulation layers. Also, because the heaters were limited in their ability to withstand elevated temperatures at high power levels, it was advantageous to gradually raise surface temperatures by decreasing flow, all the while monitoring readings to avoid exceeding any design limitations. At flow rates lower than 300 ml/min the flow was rather pulsed, due to the nature of the pump, rather than a steady flow. Flow rates greater than 1000 ml/min and less than 300 ml/min were not used in order to avoid the extremes in flowmeter settings.

POWER SETTING	HEATER FLUX $q''$ (W/cm <sup>2</sup> )	TOTAL POWER INPUT $P_{total}$ (W)
1	1.5	17.42
2	2.0	23.23
3	2.5	29.03
4	3.0	34.84
5	3.5	40.65
6	4.0	46.45
7	4.5	52.26
8	5.0	58.06
9	5.5	63.87
10	6.0	69.68

Table 1. Power settings for experiments.

## B. DATA ANALYSIS

Data was analyzed as follows to obtain information on the heat dissipation occurring at each flow level and power setting.

### 1. Calculation of Coolant Thermophysical Properties

Thermophysical properties were calculated by using the average of the inlet and outlet temperatures (T(3) and T(4) respectively) of the coolant passing through the module, determined as follows:

$$T_{avg} = \frac{(T(4) + T(3))}{2} \quad (4)$$

#### a. Density (g/ml)

Manufacturer's data, shown in the Table 2, was used to determine the coolant density at  $T_{avg}$  by linear interpolation using the equation shown.

$$\rho = 0.794 - (8.5E-4) * (T_{avg} - 20) \quad (5)$$

TEMPERATURE	DENSITY (g/ml)
0°C (32°F)	0.811
20°C (68°F)	0.794
40°C (104°F)	0.777
100°C (212°F)	0.723
160°C (320°F)	0.661

Table 2. Brayco Micronic 889 density (Castrol, 1994).

#### b. Specific Heat $C_p$ (J/g°C)

Specific heat was similarly determined using the equation below and manufacturer's data, shown in Table 3, through a method of linear interpolation.

$$C_p = (0.52 + (7.1E-4) * (T_{avg} - 10)) * 4.184 \text{ J/cal} \quad (6)$$

TEMPERATURE	SPECIFIC HEAT (cal/g°C)
-18°C (0°F)	0.49
10°C (50°F)	0.52
38°C (100°F)	0.54
93°C (200°F)	0.58

**Table 3.** Brayco Micronic 889 specific heat (Castrol, 1994).

## 2. Calculation of Heat Dissipation

### a. Temperature Differential

Sixty samples of inlet and outlet temperatures (T(3) and T(4)) taken at steady state by the data collection program were used to calculate an average delta T as follows:

$$\Delta T_{\text{avg}} = \sum_{i=1}^{60} \frac{T_i(4) - T_i(3)}{60} \quad (7)$$

### b. Heat Dissipated by the Coolant $Q_f$ (W)

$$Q_f = \frac{\rho v C_p \Delta T_{\text{avg}}}{60} \quad (8)$$

where  $v$  = flow rate in ml/min

### c. Heat Losses Through the Insulation $Q_{\text{ins}}$ (W)

In order to quantify heat losses to the atmosphere, thermocouple measurements in the insulation layers (see Figure 6) were used to provide an estimate of conduction losses ( $Q_{\text{ins}}$ ) along one heat flow path.

$$Q_{ins} = \frac{kA}{L} (T(2) - T(1)) \quad (9)$$

where k = insulation conductivity

= 0.04 W/(m°C),

A = surface area of insulation

= 5.66 inches x 6 inches

= 33.96 in<sup>2</sup>, or 0.0219 m<sup>2</sup>,

and L = insulation thickness between thermocouples

= 0.75 inches, or 0.0191 m.

The surface area of the insulation was estimated as the approximate area of the recessed surface of the module upon which the heaters and thermocouples were affixed.

### 3. Calculation of Power into the Heaters P<sub>h</sub> (W)

Heater power was calculated by the data collection program using equations 1 and 2 as discussed in Chapter II. Recorded values of voltage and power were truncated to two decimal places after computations within the program were completed.



## IV. RESULTS

### A. RAW TEMPERATURE DATA

Module surface and insulation layer temperature data at the ten power settings is shown in Tables 4 through 13 (refer to Figure 6 for thermocouple location diagram). The power supplied to each heater and total power into the heaters is also tabulated. Tables 14 through 23 show average inlet and outlet temperatures,  $\Delta T_{avg}$  for the coolant, as well as various temperature differentials on the module surface. Graphical representations of temperature patterns on the module surface are shown in Figures 7 through 16 for flow settings of 300, 600, and 1000 ml/min. The average of the inlet and outlet temperature differentials are plotted in Figure 17. Figure 18 shows the same data on a log-log scale.

### B. HEAT TRANSFER DATA

The temperature data was input into the equations in Chapter III to produce the heat transfer calculations shown in Tables 14 through 23. Graphical representations of the data for  $Q_f$  over the ten power settings are shown in Figure 19. Independent laboratory tests showed the specific heat of the coolant to be less than that indicated by the manufacturer at 66°C and 93°C (based upon test results received from Delsen Testing Laboratories, Inc., on December 6, 1994). Figure 20 shows a sampling of revised  $Q_f$  calculations using an extrapolation of these  $C_p$  values. Chapter V discusses the laboratory information in greater detail, while Appendix B includes a comparison of laboratory testing results and manufacturer's data for  $C_p$ .

Figures 21 through 30 illustrate the temperature rise experienced from "inlet" to "exit" of each heater, (based on the fluid flow path as shown in Figure 6), for the ten power settings and a sampling of flows. Figures 31 through 40 are

graphs of the mid-channel temperature drop experienced between the "exit" of each heater and the next thermocouple placed on the flow path (as illustrated in Figure 6). As before, all power levels are represented by a sampling of flow settings.

Flow setting (ml/min)	300	400	500	600	700	800	900	1000
	<b>Voltages (V)</b>							
HEATER A	8.13	8.13	8.13	8.13	8.13	8.13	8.13	8.13
HEATER B	8.12	8.13	8.13	8.12	8.12	8.12	8.12	8.13
HEATER C	8.12	8.12	8.12	8.12	8.12	8.12	8.12	8.12
HEATER D	8.05	8.06	8.06	8.05	8.05	8.05	8.05	8.05
HEATER E	8.12	8.11	8.11	8.11	8.11	8.11	8.11	8.11
HEATER F	7.98	7.98	7.98	7.98	7.98	7.98	7.99	7.99
RESISTOR A	0.18	0.18	0.18	0.18	0.18	0.18	0.18	0.18
RESISTOR B	0.18	0.18	0.18	0.18	0.18	0.18	0.18	0.18
RESISTOR C	0.18	0.18	0.18	0.18	0.18	0.18	0.18	0.18
RESISTOR D	0.17	0.17	0.17	0.17	0.17	0.17	0.17	0.17
RESISTOR E	0.18	0.18	0.18	0.18	0.18	0.18	0.18	0.18
RESISTOR F	0.17	0.17	0.17	0.17	0.17	0.17	0.17	0.17
	<b>Power (W)</b>							
HEATER A	2.95	2.95	2.95	2.95	2.95	2.95	2.95	2.95
HEATER B	2.94	2.94	2.94	2.94	2.94	2.94	2.94	2.94
HEATER C	2.92	2.92	2.92	2.92	2.92	2.92	2.92	2.92
HEATER D	2.86	2.86	2.86	2.86	2.86	2.86	2.86	2.86
HEATER E	2.92	2.91	2.92	2.91	2.91	2.91	2.91	2.92
HEATER F	2.84	2.84	2.85	2.84	2.85	2.85	2.85	2.85
<b>Total Power</b>	<b>17.43</b>	<b>17.42</b>	<b>17.44</b>	<b>17.42</b>	<b>17.43</b>	<b>17.43</b>	<b>17.43</b>	<b>17.44</b>
	<b>Thermocouple temps (degrees Celsius)</b>							
0	16.88	16.92	16.87	16.86	17.02	17.51	16.62	16.83
1	17.42	17.31	17.32	17.35	17.54	17.37	17.23	17.34
2	18.04	17.82	17.74	17.73	17.74	17.63	17.60	17.66
3	16.73	16.89	16.61	16.57	16.62	16.59	16.98	16.79
4	18.92	18.30	17.92	17.71	17.62	17.49	17.58	17.55
5	17.84	17.73	17.44	17.35	17.33	17.28	17.55	17.41
6	18.10	17.96	17.64	17.52	17.48	17.47	17.70	17.57
7	17.51	17.37	17.06	16.96	16.96	16.94	17.17	17.04
8	18.39	18.13	17.78	17.65	17.63	17.56	17.80	17.66
9	18.56	18.27	17.91	17.77	17.73	17.65	17.90	17.74
10	18.67	18.26	17.88	17.71	17.63	17.57	17.73	17.62
11	18.98	18.55	18.14	17.97	17.90	17.84	17.99	17.87
12	18.29	17.87	17.50	17.33	17.28	17.24	17.40	17.31
13	19.06	18.56	18.16	17.96	17.90	17.83	17.96	17.86
14	19.22	18.72	18.27	18.09	18.00	17.95	18.08	17.96
15	19.08	18.59	18.20	18.00	17.94	17.87	17.99	17.91
16	19.65	19.08	18.70	18.48	18.39	18.31	18.44	18.35
17	18.81	18.22	17.83	17.61	17.53	17.48	17.60	17.50
18	19.67	19.01	18.60	18.34	18.24	18.16	18.27	18.16
19	19.75	19.12	18.64	18.39	18.29	18.22	18.33	18.22

Table 4. Power and temperature data at power setting 1.

Flow setting (ml/min)	300	400	500	600	700	800	900	1000
	<b>Voltages (V)</b>							
HEATER A	9.37	9.37	9.37	9.37	9.37	9.37	9.37	9.37
HEATER B	9.37	9.37	9.37	9.37	9.37	9.37	9.37	9.37
HEATER C	9.36	9.36	9.37	9.37	9.37	9.37	9.37	9.37
HEATER D	9.32	9.32	9.32	9.32	9.32	9.32	9.32	9.32
HEATER E	9.36	9.35	9.36	9.36	9.36	9.36	9.36	9.36
HEATER F	9.27	9.27	9.28	9.28	9.27	9.27	9.27	9.28
RESISTOR A	0.20	0.20	0.20	0.20	0.20	0.20	0.20	0.20
RESISTOR B	0.20	0.20	0.20	0.20	0.20	0.20	0.20	0.20
RESISTOR C	0.20	0.20	0.20	0.20	0.20	0.20	0.20	0.20
RESISTOR D	0.20	0.20	0.20	0.20	0.20	0.20	0.20	0.20
RESISTOR E	0.20	0.20	0.20	0.20	0.20	0.20	0.20	0.20
RESISTOR F	0.20	0.20	0.20	0.20	0.20	0.20	0.20	0.20
	<b>Power (W)</b>							
HEATER A	3.92	3.92	3.92	3.92	3.92	3.92	3.92	3.92
HEATER B	3.90	3.90	3.90	3.90	3.90	3.90	3.90	3.90
HEATER C	3.87	3.87	3.87	3.88	3.87	3.87	3.87	3.88
HEATER D	3.83	3.83	3.83	3.83	3.83	3.83	3.83	3.83
HEATER E	3.87	3.87	3.87	3.87	3.87	3.87	3.87	3.87
HEATER F	3.84	3.84	3.84	3.84	3.84	3.84	3.84	3.84
<b>Total Power</b>	<b>23.23</b>	<b>23.23</b>	<b>23.23</b>	<b>23.24</b>	<b>23.23</b>	<b>23.23</b>	<b>23.23</b>	<b>23.24</b>
	<b>Thermocouple temps (degrees Celsius)</b>							
0	18.52	18.45	18.32	18.26	18.23	18.13	18.07	18.00
1	18.93	18.80	18.70	18.57	18.50	18.36	18.23	18.10
2	19.69	19.39	19.24	19.05	18.96	18.82	18.64	18.44
3	18.14	17.94	17.89	18.03	17.94	17.78	17.78	17.69
4	20.85	20.02	19.65	19.32	19.08	18.91	18.75	18.65
5	19.63	19.23	19.02	19.00	18.89	18.72	18.67	18.57
6	19.90	19.45	19.24	19.18	19.04	18.87	18.83	18.71
7	19.13	18.68	18.47	18.46	18.30	18.14	18.12	18.04
8	20.25	19.70	19.46	19.36	19.20	18.99	18.95	18.82
9	20.47	19.87	19.61	19.51	19.31	19.11	19.05	18.93
10	20.56	19.88	19.56	19.37	19.18	18.97	18.89	18.78
11	21.00	20.26	19.93	19.74	19.51	19.30	19.22	19.09
12	20.07	19.39	19.07	18.90	18.72	18.52	18.45	18.35
13	21.12	20.37	19.98	19.76	19.53	19.33	19.24	19.10
14	21.29	20.53	20.15	19.91	19.71	19.48	19.38	19.27
15	21.16	20.40	19.99	19.76	19.59	19.39	19.27	19.15
16	21.84	21.02	20.61	20.34	20.12	19.93	19.81	19.68
17	20.73	19.93	19.49	19.25	19.05	18.85	18.75	18.64
18	21.90	20.98	20.53	20.22	19.97	19.77	19.65	19.52
19	22.02	21.11	20.62	20.31	20.06	19.85	19.73	19.62

Table 5. Power and temperature data at power setting 2.

Flow setting (ml/min)	300	400	500	600	700	800	900	1000
	Voltages (V)							
HEATER A	10.48	10.48	10.48	10.48	10.48	10.48	10.48	10.48
HEATER B	10.48	10.47	10.47	10.47	10.47	10.47	10.47	10.47
HEATER C	10.47	10.47	10.47	10.47	10.47	10.47	10.47	10.47
HEATER D	10.42	10.42	10.42	10.42	10.42	10.42	10.42	10.42
HEATER E	10.46	10.46	10.46	10.46	10.46	10.46	10.46	10.46
HEATER F	10.39	10.38	10.38	10.38	10.38	10.38	10.38	10.38
RESISTOR A	0.23	0.23	0.23	0.23	0.23	0.23	0.23	0.23
RESISTOR B	0.23	0.23	0.23	0.23	0.23	0.23	0.23	0.23
RESISTOR C	0.23	0.23	0.23	0.23	0.23	0.23	0.23	0.23
RESISTOR D	0.22	0.22	0.22	0.22	0.22	0.22	0.22	0.22
RESISTOR E	0.23	0.23	0.23	0.23	0.23	0.23	0.23	0.23
RESISTOR F	0.23	0.23	0.23	0.23	0.23	0.23	0.23	0.23
	Power (W)							
HEATER A	4.89	4.89	4.89	4.89	4.89	4.89	4.89	4.89
HEATER B	4.87	4.87	4.87	4.87	4.87	4.87	4.87	4.87
HEATER C	4.84	4.84	4.84	4.84	4.84	4.84	4.84	4.84
HEATER D	4.78	4.78	4.78	4.78	4.78	4.78	4.78	4.78
HEATER E	4.84	4.83	4.83	4.83	4.83	4.83	4.83	4.83
HEATER F	4.81	4.80	4.80	4.80	4.80	4.80	4.80	4.80
Total power	29.03	29.01	29.01	29.01	29.01	29.01	29.01	29.01
	Thermocouple temps (degrees Celsius)							
0	20.18	20.20	20.23	20.23	20.38	20.20	20.32	20.23
1	20.99	20.94	20.81	20.76	20.77	20.70	20.76	20.83
2	22.00	21.63	21.39	21.31	21.23	21.14	21.13	21.16
3	19.71	19.77	19.84	19.76	19.58	19.58	19.51	19.68
4	23.06	22.25	21.72	21.42	21.13	20.96	20.75	20.67
5	21.47	21.23	21.09	20.95	20.73	20.68	20.57	20.62
6	21.89	21.60	21.40	21.20	20.99	20.88	20.78	20.85
7	20.89	20.58	20.42	20.27	20.08	20.00	19.92	20.00
8	22.30	21.88	21.66	21.42	21.18	21.07	20.96	20.98
9	22.57	22.11	21.83	21.60	21.34	21.22	21.08	21.13
10	22.71	22.10	21.73	21.45	21.17	21.05	20.90	20.90
11	23.24	22.58	22.17	21.89	21.62	21.44	21.29	21.29
12	22.09	21.49	21.11	20.87	20.61	20.49	20.34	20.35
13	23.39	22.68	22.24	21.94	21.65	21.46	21.29	21.27
14	23.63	22.89	22.43	22.13	21.83	21.66	21.47	21.44
15	23.43	22.71	22.24	21.95	21.70	21.52	21.36	21.31
16	24.28	23.49	22.99	22.64	22.36	22.20	22.00	21.93
17	22.90	22.12	21.63	21.32	21.01	20.86	20.67	20.63
18	24.38	23.47	22.91	22.52	22.21	22.01	21.81	21.73
19	24.57	23.60	23.01	22.64	22.31	22.13	21.88	21.84

Table 6. Power and temperature data at power setting 3.

Flow setting (ml/min)	300	400	500	600	700	800	900	1000
	Voltages (V)							
HEATER A	11.51	11.51	11.51	11.51	11.51	11.51	11.51	11.51
HEATER B	11.50	11.50	11.50	11.51	11.51	11.51	11.51	11.51
HEATER C	11.50	11.51	11.50	11.50	11.50	11.51	11.50	11.50
HEATER D	11.39	11.39	11.39	11.40	11.40	11.40	11.40	11.40
HEATER E	11.49	11.49	11.49	11.49	11.49	11.49	11.49	11.49
HEATER F	11.30	11.30	11.28	11.28	11.29	11.28	11.26	11.27
RESISTOR A	0.25	0.25	0.25	0.25	0.25	0.25	0.25	0.25
RESISTOR B	0.25	0.25	0.25	0.25	0.25	0.25	0.25	0.25
RESISTOR C	0.25	0.25	0.25	0.25	0.25	0.25	0.25	0.25
RESISTOR D	0.24	0.24	0.24	0.24	0.24	0.24	0.24	0.24
RESISTOR E	0.25	0.25	0.25	0.25	0.25	0.25	0.25	0.25
RESISTOR F	0.25	0.25	0.24	0.25	0.25	0.24	0.24	0.24
	Power (W)							
HEATER A	5.90	5.90	5.90	5.90	5.90	5.90	5.90	5.90
HEATER B	5.87	5.87	5.87	5.88	5.88	5.88	5.88	5.87
HEATER C	5.83	5.84	5.83	5.84	5.84	5.84	5.84	5.83
HEATER D	5.71	5.72	5.72	5.72	5.72	5.72	5.72	5.72
HEATER E	5.83	5.83	5.83	5.83	5.83	5.84	5.83	5.83
HEATER F	5.68	5.68	5.67	5.67	5.68	5.67	5.65	5.65
Total Power	34.82	34.84	34.82	34.84	34.85	34.85	34.82	34.80
	Thermocouple temps (degrees Celsius)							
0	18.40	18.21	18.22	18.51	18.51	18.60	18.82	18.52
1	19.47	19.45	19.48	19.54	19.53	19.51	19.46	19.58
2	20.82	20.66	20.60	20.48	20.44	20.37	20.32	20.33
3	18.63	18.52	18.67	18.69	18.82	18.92	18.85	18.78
4	22.67	21.56	20.98	20.68	20.66	20.53	20.32	20.17
5	20.85	20.38	20.30	20.24	20.30	20.32	20.15	20.04
6	21.24	20.72	20.56	20.49	20.51	20.54	20.39	20.26
7	20.06	19.54	19.40	19.37	19.41	19.42	19.36	19.23
8	21.75	21.07	20.85	20.74	20.74	20.73	20.58	20.45
9	22.09	21.37	21.08	20.95	20.94	20.94	20.74	20.61
10	22.24	21.36	20.97	20.80	20.75	20.70	20.52	20.36
11	22.87	21.95	21.54	21.34	21.26	21.20	21.01	20.83
12	21.49	20.64	20.26	20.10	20.07	20.04	19.88	19.70
13	23.06	22.07	21.59	21.36	21.31	21.21	21.05	20.84
14	23.34	22.34	21.85	21.62	21.55	21.46	21.25	21.04
15	23.11	22.13	21.65	21.40	21.38	21.30	21.10	20.91
16	24.22	23.16	22.60	22.36	22.27	22.19	21.96	21.77
17	22.48	21.42	20.88	20.66	20.60	20.52	20.32	20.11
18	24.20	23.01	22.37	22.09	22.00	21.89	21.66	21.43
19	24.44	23.21	22.54	22.24	22.15	22.04	21.80	21.58

Table 7. Power and temperature data at power setting 4.

Flow setting (ml/min)	300	400	500	600	700	800	900	1000
	Voltages (V)							
Heater A	12.41	12.41	12.41	12.41	12.41	12.41	12.41	12.41
Heater B	12.41	12.41	12.41	12.40	12.40	12.40	12.40	12.40
Heater C	12.40	12.40	12.40	12.40	12.40	12.40	12.40	12.40
Heater D	12.34	12.34	12.34	12.34	12.34	12.34	12.34	12.34
Heater E	12.39	12.39	12.39	12.39	12.39	12.39	12.39	12.39
Heater F	12.30	12.30	12.30	12.30	12.30	12.30	12.30	12.30
RESISTOR A	0.27	0.27	0.27	0.27	0.27	0.27	0.27	0.27
RESISTOR B	0.27	0.27	0.27	0.27	0.27	0.27	0.27	0.27
RESISTOR C	0.27	0.27	0.27	0.27	0.27	0.27	0.27	0.27
RESISTOR D	0.26	0.26	0.26	0.26	0.26	0.26	0.26	0.26
RESISTOR E	0.27	0.27	0.27	0.27	0.27	0.27	0.27	0.27
RESISTOR F	0.27	0.27	0.27	0.27	0.27	0.27	0.27	0.27
	Power (W)							
Heater A	6.85	6.85	6.85	6.85	6.85	6.85	6.85	6.85
Heater B	6.82	6.82	6.82	6.82	6.82	6.82	6.82	6.82
Heater C	6.78	6.78	6.78	6.78	6.78	6.78	6.78	6.78
Heater D	6.70	6.70	6.70	6.70	6.70	6.70	6.70	6.70
Heater E	6.77	6.77	6.77	6.77	6.77	6.77	6.77	6.77
Heater F	6.73	6.73	6.73	6.73	6.73	6.73	6.73	6.73
Total Power	40.65	40.65	40.65	40.65	40.65	40.65	40.65	40.65
	Thermocouple temps (degrees Celsius)							
0	20.51	20.34	20.34	20.34	20.34	20.33	20.30	20.17
1	21.24	21.12	21.05	20.98	20.88	20.81	20.67	20.41
2	22.49	22.18	21.98	21.80	21.69	21.54	21.37	21.06
3	19.87	19.74	19.80	19.67	19.78	19.67	19.50	19.68
4	24.49	23.17	22.53	22.13	21.77	21.44	21.23	21.07
5	22.42	21.88	21.68	21.47	21.40	21.19	21.03	21.06
6	22.84	22.24	22.01	21.75	21.70	21.48	21.32	21.33
7	21.50	20.87	20.66	20.47	20.41	20.21	20.08	20.13
8	23.46	22.67	22.36	22.07	21.94	21.71	21.52	21.53
9	23.84	22.99	22.62	22.33	22.20	21.91	21.71	21.70
10	24.03	22.98	22.49	22.15	21.95	21.62	21.44	21.40
11	24.76	23.63	23.12	22.74	22.53	22.24	22.02	21.93
12	23.16	22.09	21.64	21.32	21.13	20.86	20.66	20.63
13	24.98	23.77	23.22	22.83	22.57	22.24	22.02	21.96
14	25.29	24.07	23.52	23.11	22.83	22.51	22.25	22.21
15	25.03	23.82	23.27	22.90	22.60	22.30	22.09	21.97
16	26.21	24.92	24.30	23.88	23.57	23.22	22.99	22.89
17	24.30	22.97	22.37	21.98	21.70	21.35	21.19	21.08
18	26.30	24.90	24.17	23.70	23.35	22.99	22.76	22.63
19	26.58	25.08	24.34	23.89	23.50	23.12	22.89	22.76

Table 8. Power and temperature data at power setting 5.

Flow setting (ml/min)	300	400	500	600	700	800	900	1000
	Voltages (V)							
HEATER A	13.29	13.29	13.29	13.29	13.29	13.29	13.28	13.28
HEATER B	13.28	13.28	13.28	13.29	13.29	13.29	13.28	13.28
HEATER C	13.28	13.28	13.28	13.28	13.28	13.28	13.27	13.28
HEATER D	13.17	13.17	13.17	13.17	13.17	13.17	13.16	13.16
HEATER E	13.26	13.26	13.26	13.26	13.26	13.26	13.26	13.26
HEATER F	13.08	13.08	13.07	13.07	13.07	13.07	13.09	13.11
RESISTOR A	0.29	0.29	0.29	0.29	0.29	0.29	0.29	0.29
RESISTOR B	0.29	0.29	0.29	0.29	0.29	0.29	0.29	0.29
RESISTOR C	0.29	0.29	0.29	0.29	0.29	0.29	0.29	0.29
RESISTOR D	0.28	0.28	0.28	0.28	0.28	0.28	0.28	0.28
RESISTOR E	0.29	0.29	0.29	0.29	0.29	0.29	0.29	0.29
RESISTOR F	0.28	0.28	0.28	0.28	0.28	0.28	0.28	0.28
	Power (W)							
HEATER A	7.85	7.86	7.86	7.86	7.86	7.86	7.85	7.85
HEATER B	7.82	7.82	7.82	7.83	7.83	7.83	7.82	7.82
HEATER C	7.76	7.77	7.77	7.77	7.77	7.77	7.76	7.76
HEATER D	7.62	7.62	7.62	7.63	7.63	7.63	7.62	7.61
HEATER E	7.76	7.76	7.76	7.77	7.77	7.77	7.76	7.76
HEATER F	7.61	7.60	7.60	7.59	7.60	7.60	7.62	7.64
Total Power	46.42	46.43	46.43	46.45	46.46	46.46	46.43	46.44
	Thermocouple temps (degrees Celsius)							
0	19.07	18.20	18.17	18.26	18.17	18.69	18.02	18.11
1	20.50	19.46	19.47	19.50	19.38	19.02	18.84	18.44
2	22.07	21.04	20.79	20.65	20.43	20.16	19.95	19.31
3	18.35	18.30	18.34	18.22	18.41	18.42	18.44	18.23
4	23.92	22.29	21.48	20.98	20.64	20.39	20.21	20.00
5	21.32	20.74	20.49	20.26	20.25	20.15	20.15	19.92
6	21.91	21.19	20.88	20.59	20.57	20.49	20.42	20.19
7	20.33	19.63	19.34	19.11	19.10	19.06	19.01	18.81
8	22.60	21.66	21.24	20.92	20.87	20.75	20.66	20.41
9	23.07	22.04	21.58	21.24	21.16	21.01	20.91	20.64
10	23.31	22.05	21.45	21.04	20.85	20.68	20.56	20.31
11	24.18	22.81	22.18	21.74	21.52	21.36	21.19	20.94
12	22.31	21.03	20.45	20.08	19.91	19.76	19.65	19.42
13	24.47	22.96	22.27	21.79	21.57	21.37	21.21	20.91
14	24.82	23.31	22.61	22.12	21.87	21.66	21.48	21.20
15	24.51	23.04	22.32	21.87	21.60	21.42	21.23	21.02
16	25.94	24.37	23.58	23.09	22.80	22.55	22.39	22.10
17	23.69	22.10	21.34	20.85	20.57	20.37	20.19	19.95
18	26.00	24.21	23.35	22.79	22.44	22.16	21.97	21.71
19	26.29	24.47	23.60	23.00	22.62	22.34	22.17	21.88

Table 9. Power and temperature data at power setting 6.

Flow setting (ml/min)	300	400	500	600	700	800	900	1000
	Voltages (V)							
HEATER A	14.08	14.08	14.08	14.08	14.08	14.08	14.08	14.08
HEATER B	14.08	14.08	14.08	14.07	14.07	14.07	14.08	14.07
HEATER C	14.08	14.07	14.07	14.07	14.07	14.07	14.07	14.07
HEATER D	14.00	14.00	14.00	13.99	14.00	14.00	14.00	14.00
HEATER E	14.06	14.06	14.06	14.06	14.05	14.05	14.06	14.05
HEATER F	13.92	13.93	13.94	13.93	13.94	13.94	13.94	13.95
RESISTOR A	0.31	0.31	0.31	0.31	0.31	0.31	0.31	0.31
RESISTOR B	0.30	0.30	0.30	0.30	0.30	0.30	0.30	0.30
RESISTOR C	0.30	0.30	0.30	0.30	0.30	0.30	0.30	0.30
RESISTOR D	0.30	0.30	0.30	0.30	0.30	0.30	0.30	0.30
RESISTOR E	0.30	0.30	0.30	0.30	0.30	0.30	0.30	0.30
RESISTOR F	0.30	0.30	0.30	0.30	0.30	0.30	0.30	0.30
	Power (W)							
HEATER A	8.82	8.82	8.82	8.81	8.81	8.81	8.82	8.81
HEATER B	8.78	8.78	8.78	8.77	8.77	8.77	8.78	8.77
HEATER C	8.72	8.72	8.72	8.72	8.71	8.71	8.72	8.71
HEATER D	8.61	8.61	8.61	8.60	8.62	8.61	8.61	8.61
HEATER E	8.72	8.71	8.71	8.71	8.71	8.71	8.71	8.71
HEATER F	8.61	8.62	8.63	8.63	8.63	8.64	8.64	8.65
Total Power	52.26	52.26	52.27	52.24	52.25	52.25	52.28	52.26
	Thermocouple temps (degrees Celsius)							
0	18.47	18.64	18.65	18.62	20.52	20.33	19.20	19.99
1	20.37	20.13	20.04	19.88	21.12	20.50	19.55	19.89
2	22.62	21.94	21.68	21.32	21.95	21.29	20.68	20.67
3	18.57	18.92	18.98	18.95	19.02	19.01	18.87	18.72
4	24.63	23.33	22.46	21.91	21.62	21.31	21.02	20.71
5	21.90	21.69	21.44	21.23	21.13	21.06	20.79	20.65
6	22.46	22.16	21.82	21.59	21.54	21.39	21.13	20.93
7	20.70	20.39	20.11	19.90	19.86	19.78	19.59	19.39
8	23.23	22.71	22.25	21.97	21.82	21.66	21.42	21.17
9	23.74	23.12	22.61	22.30	22.13	21.94	21.69	21.43
10	24.03	23.12	22.44	22.07	21.82	21.62	21.34	21.06
11	24.95	23.99	23.28	22.85	22.58	22.35	22.08	21.77
12	22.89	22.00	21.37	20.99	20.77	20.57	20.39	20.07
13	25.28	24.18	23.40	22.94	22.65	22.42	22.10	21.80
14	25.66	24.56	23.77	23.28	23.00	22.72	22.44	22.10
15	25.34	24.23	23.45	22.97	22.72	22.46	22.20	21.89
16	26.86	25.63	24.80	24.28	23.93	23.65	23.42	23.01
17	24.42	23.18	22.35	21.85	21.54	21.29	21.05	20.69
18	27.05	25.62	24.68	24.09	23.63	23.35	23.15	22.69
19	27.36	25.88	24.90	24.31	23.85	23.55	23.34	22.86

Table 10. Power and temperature data at power setting 7.

Flow settings (ml/min)	300	400	500	600	700	800	900	1000
	Voltages (V)							
HEATER A	14.84	14.84	14.84	14.84	14.84	14.84	14.84	14.84
HEATER B	14.84	14.84	14.84	14.84	14.84	14.84	14.84	14.84
HEATER C	14.84	14.84	14.84	14.83	14.83	14.83	14.83	14.84
HEATER D	14.74	14.74	14.74	14.74	14.74	14.74	14.74	14.74
HEATER E	14.82	14.82	14.82	14.82	14.82	14.82	14.82	14.82
HEATER F	14.72	14.72	14.73	14.72	14.72	14.72	14.71	14.70
RESISTOR A	0.32	0.32	0.32	0.32	0.32	0.32	0.32	0.32
RESISTOR B	0.32	0.32	0.32	0.32	0.32	0.32	0.32	0.32
RESISTOR C	0.32	0.32	0.32	0.32	0.32	0.32	0.32	0.32
RESISTOR D	0.32	0.32	0.32	0.32	0.32	0.32	0.32	0.32
RESISTOR E	0.32	0.32	0.32	0.32	0.32	0.32	0.32	0.32
RESISTOR F	0.32	0.32	0.32	0.32	0.32	0.32	0.32	0.32
	Power (W)							
HEATER A	9.79	9.79	9.79	9.79	9.79	9.79	9.79	9.79
HEATER B	9.75	9.75	9.75	9.75	9.75	9.75	9.75	9.75
HEATER C	9.68	9.68	9.68	9.68	9.68	9.68	9.68	9.68
HEATER D	9.54	9.54	9.54	9.54	9.54	9.54	9.54	9.54
HEATER E	9.68	9.68	9.68	9.68	9.68	9.68	9.68	9.68
HEATER F	9.62	9.62	9.63	9.62	9.62	9.62	9.62	9.61
Total Power	58.06	58.06	58.07	58.06	58.06	58.06	58.06	58.05
	Thermocouple temps (degrees Celsius)							
0	18.67	18.77	18.76	18.79	18.69	18.68	18.71	19.01
1	20.40	20.19	20.08	20.04	19.95	19.94	19.96	20.11
2	22.73	22.21	21.85	21.70	21.53	21.41	21.36	21.34
3	19.35	19.23	19.22	19.17	19.17	19.26	19.33	19.23
4	25.90	24.15	23.22	22.55	22.11	21.80	21.60	21.38
5	22.82	22.10	21.78	21.53	21.36	21.34	21.31	21.15
6	23.61	22.78	22.38	22.08	21.89	21.83	21.78	21.61
7	21.68	20.83	20.45	20.21	20.05	20.02	20.02	19.90
8	24.46	23.40	22.87	22.48	22.24	22.16	22.09	21.87
9	25.02	23.87	23.29	22.88	22.62	22.49	22.40	22.17
10	25.23	23.82	23.08	22.58	22.24	22.06	21.94	21.73
11	26.28	24.80	24.00	23.45	23.09	22.90	22.73	22.49
12	24.01	22.59	21.87	21.40	21.09	20.94	20.82	20.59
13	26.61	25.01	24.16	23.56	23.17	22.92	22.75	22.51
14	27.07	25.43	24.57	23.95	23.56	23.28	23.10	22.85
15	26.65	25.05	24.20	23.58	23.22	22.97	22.81	22.58
16	28.29	26.57	25.64	24.99	24.56	24.27	24.08	23.81
17	25.66	23.90	22.97	22.34	21.94	21.68	21.49	21.27
18	28.57	26.62	25.55	24.85	24.36	24.03	23.81	23.50
19	28.92	26.91	25.82	25.07	24.56	24.23	23.99	23.69

Table 11. Power and temperature data at power setting 8.

Flow setting (ml/min)	300	400	500	600	700	800	900	1000
	Voltages (V)							
HEATER A	15.57	15.57	15.57	15.57	15.57	15.57	15.57	15.57
HEATER B	15.57	15.57	15.57	15.57	15.57	15.57	15.57	15.57
HEATER C	15.56	15.56	15.56	15.56	15.56	15.56	15.56	15.56
HEATER D	15.47	15.47	15.47	15.47	15.47	15.47	15.47	15.47
HEATER E	15.55	15.55	15.55	15.55	15.55	15.55	15.55	15.55
HEATER F	15.45	15.43	15.43	15.43	15.43	15.43	15.43	15.43
RESISTOR A	0.34	0.34	0.34	0.34	0.34	0.34	0.34	0.34
RESISTOR B	0.34	0.34	0.34	0.34	0.34	0.34	0.34	0.34
RESISTOR C	0.33	0.33	0.33	0.33	0.33	0.33	0.33	0.33
RESISTOR D	0.33	0.33	0.33	0.33	0.33	0.33	0.33	0.33
RESISTOR E	0.33	0.33	0.33	0.33	0.33	0.33	0.33	0.33
RESISTOR F	0.33	0.33	0.33	0.33	0.33	0.33	0.33	0.33
	Power (W)							
HEATER A	10.77	10.77	10.77	10.77	10.77	10.77	10.77	10.77
HEATER B	10.72	10.72	10.72	10.72	10.72	10.72	10.72	10.72
HEATER C	10.65	10.65	10.65	10.65	10.65	10.65	10.65	10.65
HEATER D	10.50	10.50	10.50	10.50	10.50	10.50	10.50	10.51
HEATER E	10.64	10.64	10.64	10.64	10.65	10.65	10.65	10.65
HEATER F	10.59	10.56	10.57	10.57	10.57	10.57	10.57	10.56
Total Power	63.87	63.84	63.85	63.85	63.86	63.86	63.86	63.86
	Thermocouple temps (degrees C)							
0	17.74	18.11	18.32	18.37	18.23	18.17	18.12	17.99
1	19.71	19.76	19.66	19.60	19.41	19.32	19.23	19.18
2	22.27	21.71	21.42	21.30	21.03	20.89	20.81	20.84
3	18.28	18.26	18.33	18.39	18.23	18.34	18.11	18.25
4	25.87	23.78	22.71	21.98	21.53	21.17	20.70	20.55
5	22.27	21.54	21.21	21.02	20.69	20.59	20.29	20.29
6	23.06	22.22	21.88	21.59	21.29	21.22	20.85	20.87
7	20.94	20.10	19.73	19.54	19.27	19.23	18.93	18.99
8	24.02	22.90	22.39	22.05	21.72	21.59	21.19	21.18
9	24.68	23.44	22.83	22.48	22.10	21.93	21.50	21.50
10	25.00	23.40	22.65	22.13	21.71	21.48	21.07	20.98
11	26.13	24.45	23.65	23.09	22.65	22.40	21.95	21.88
12	23.62	22.03	21.31	20.85	20.47	20.27	19.84	19.78
13	26.55	24.69	23.80	23.20	22.73	22.46	21.97	21.85
14	27.02	25.19	24.27	23.65	23.16	22.86	22.37	22.25
15	26.59	24.76	23.84	23.23	22.79	22.48	22.04	21.89
16	28.38	26.39	25.41	24.74	24.23	23.92	23.41	23.24
17	25.55	23.50	22.54	21.87	21.40	21.12	20.64	20.52
18	28.75	26.44	25.35	24.57	24.05	23.64	23.13	22.94
19	29.16	26.77	25.62	24.84	24.25	23.87	23.35	23.14

Table 12. Power and temperature data at power setting 9.

Flow setting (ml/min)	300	400	500	600	700	800	900	1000
	Voltages (V)							
HEATER A	16.27	16.27	16.27	16.27	16.27	16.27	16.27	16.27
HEATER B	16.27	16.27	16.27	16.27	16.27	16.27	16.27	16.27
HEATER C	16.26	16.26	16.26	16.26	16.26	16.26	16.27	16.26
HEATER D	16.17	16.17	16.17	16.16	16.16	16.16	16.17	16.16
HEATER E	16.25	16.25	16.25	16.25	16.25	16.24	16.25	16.24
HEATER F	16.11	16.11	16.11	16.11	16.12	16.11	16.12	16.10
RESISTOR A	0.35	0.35	0.35	0.35	0.35	0.35	0.35	0.35
RESISTOR B	0.35	0.35	0.35	0.35	0.35	0.35	0.35	0.35
RESISTOR C	0.35	0.35	0.35	0.35	0.35	0.35	0.35	0.35
RESISTOR D	0.35	0.35	0.35	0.35	0.35	0.35	0.35	0.35
RESISTOR E	0.35	0.35	0.35	0.35	0.35	0.35	0.35	0.35
RESISTOR F	0.35	0.35	0.35	0.35	0.35	0.35	0.35	0.35
	Power (W)							
HEATER A	11.75	11.75	11.75	11.75	11.76	11.75	11.76	11.76
HEATER B	11.70	11.70	11.70	11.70	11.70	11.70	11.71	11.70
HEATER C	11.62	11.62	11.62	11.62	11.62	11.62	11.63	11.62
HEATER D	11.46	11.46	11.46	11.46	11.45	11.46	11.47	11.47
HEATER E	11.61	11.62	11.62	11.62	11.62	11.62	11.62	11.62
HEATER F	11.51	11.52	11.52	11.52	11.53	11.52	11.52	11.50
Total Power	69.65	69.67	69.67	69.67	69.68	69.67	69.71	69.67
	Thermocouple temps (degrees C)							
0	18.51	18.47	18.46	18.50	19.21	18.21	18.10	17.80
1	20.35	20.20	20.04	19.74	20.32	19.33	18.87	18.20
2	22.92	22.40	22.06	21.56	21.51	21.00	20.49	19.62
3	18.47	18.33	18.29	18.41	17.98	18.19	18.14	18.23
4	26.67	24.33	23.12	22.40	21.54	21.32	20.95	20.78
5	22.85	21.92	21.49	21.33	20.81	20.83	20.64	20.61
6	23.69	22.69	22.17	21.94	21.29	21.36	21.18	21.14
7	21.36	20.35	19.87	19.70	19.10	19.17	19.08	19.07
8	24.73	23.41	22.76	22.44	21.70	21.75	21.52	21.47
9	25.40	23.97	23.24	22.87	22.16	22.13	21.90	21.81
10	25.76	23.95	23.02	22.54	21.74	21.65	21.39	21.25
11	26.97	25.12	24.15	23.60	22.74	22.65	22.35	22.23
12	24.25	22.48	21.58	21.12	20.35	20.32	20.05	19.98
13	27.43	25.38	24.32	23.71	22.84	22.71	22.38	22.23
14	27.93	25.87	24.81	24.18	23.31	23.18	22.82	22.65
15	27.47	25.42	24.35	23.76	22.90	22.77	22.44	22.30
16	29.42	27.21	26.05	25.35	24.50	24.29	23.93	23.75
17	26.29	24.07	22.91	22.23	21.39	21.23	20.92	20.77
18	29.80	27.28	25.99	25.17	24.29	24.00	23.62	23.39
19	30.19	27.62	26.26	25.45	24.51	24.27	23.85	23.64

Table 13. Power and temperature data at power setting 10.

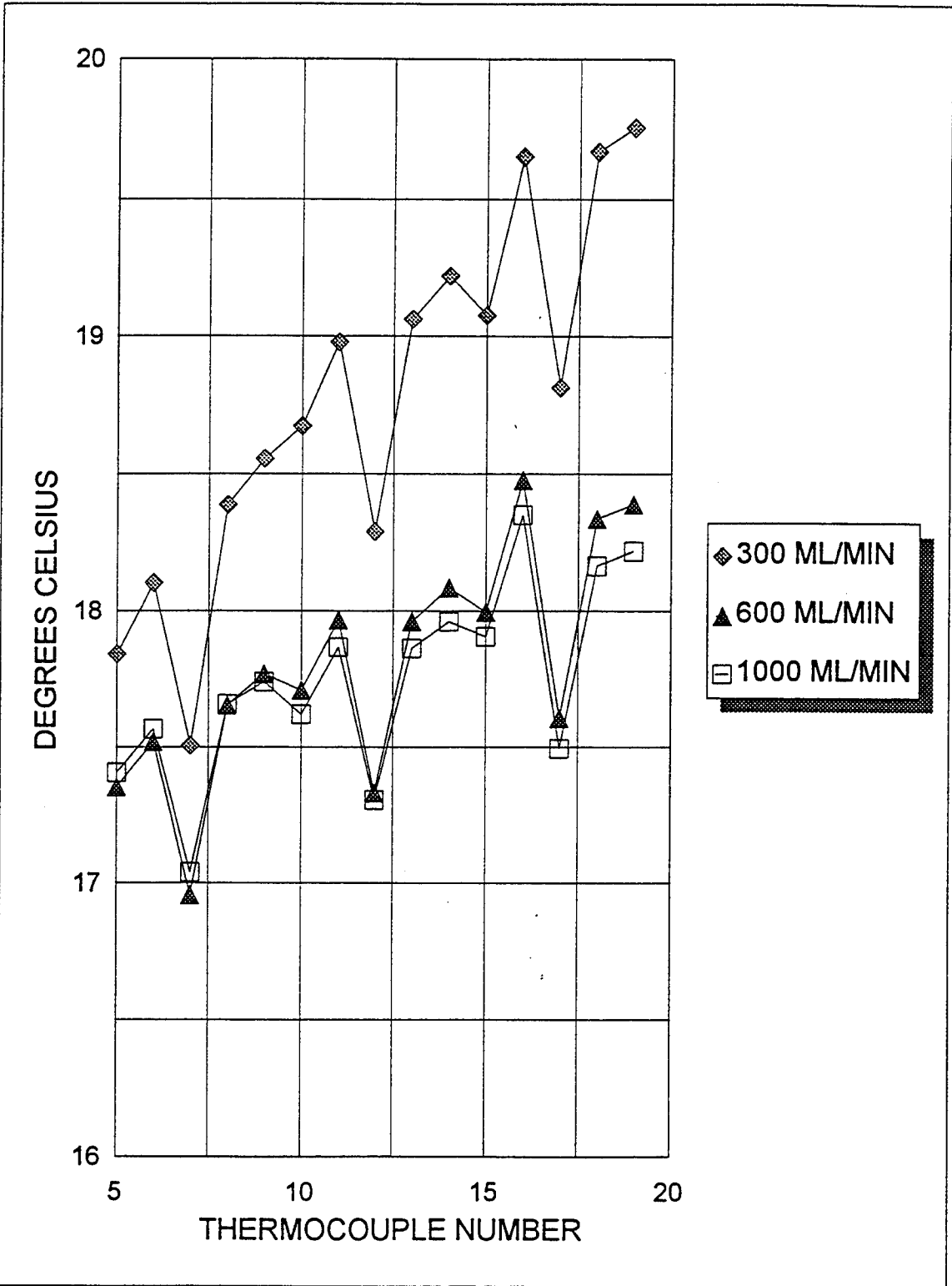

Figure 7. Module surface temperatures at power setting 1.

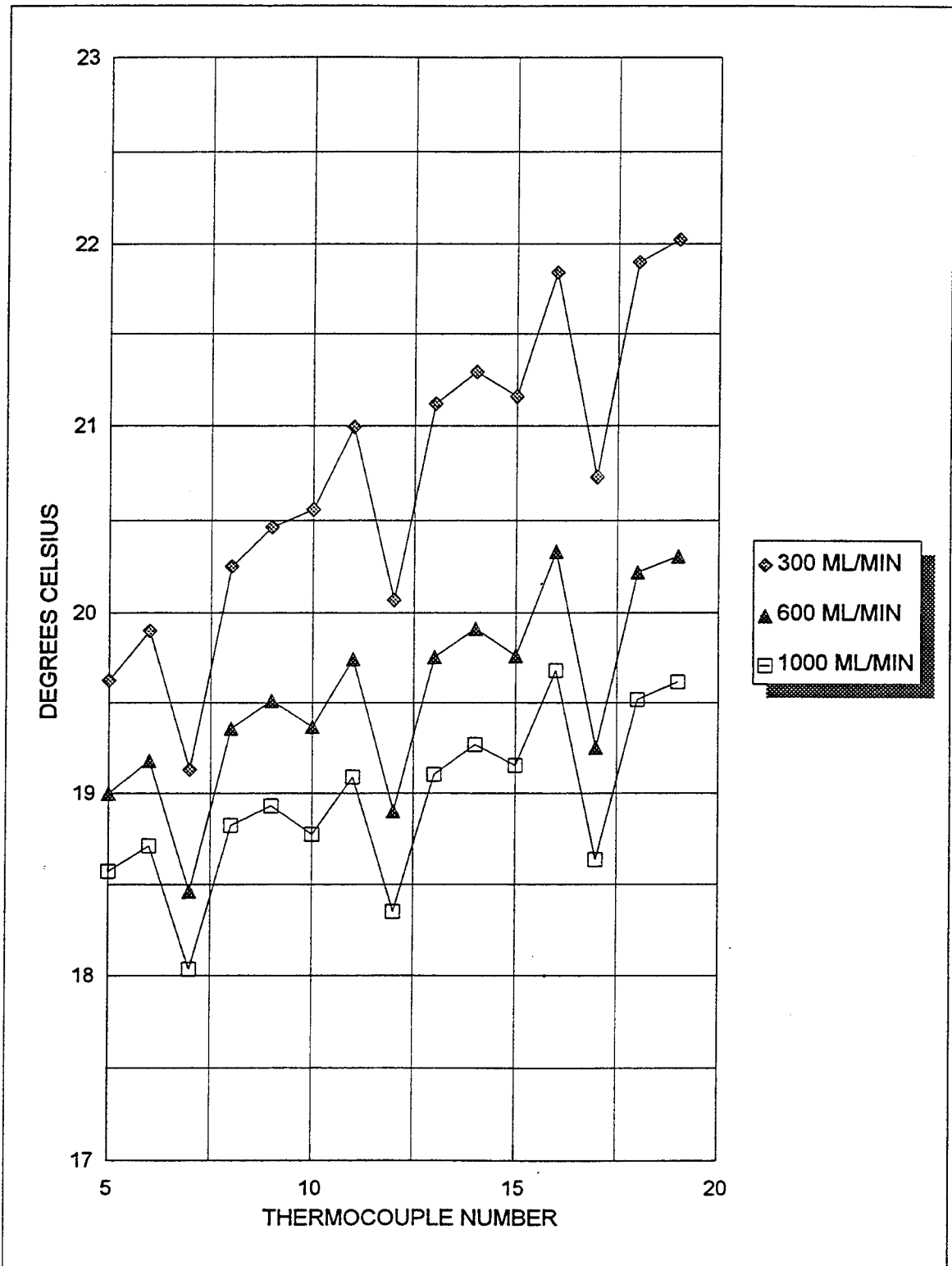

Figure 8. Module surface temperatures at power setting 2.

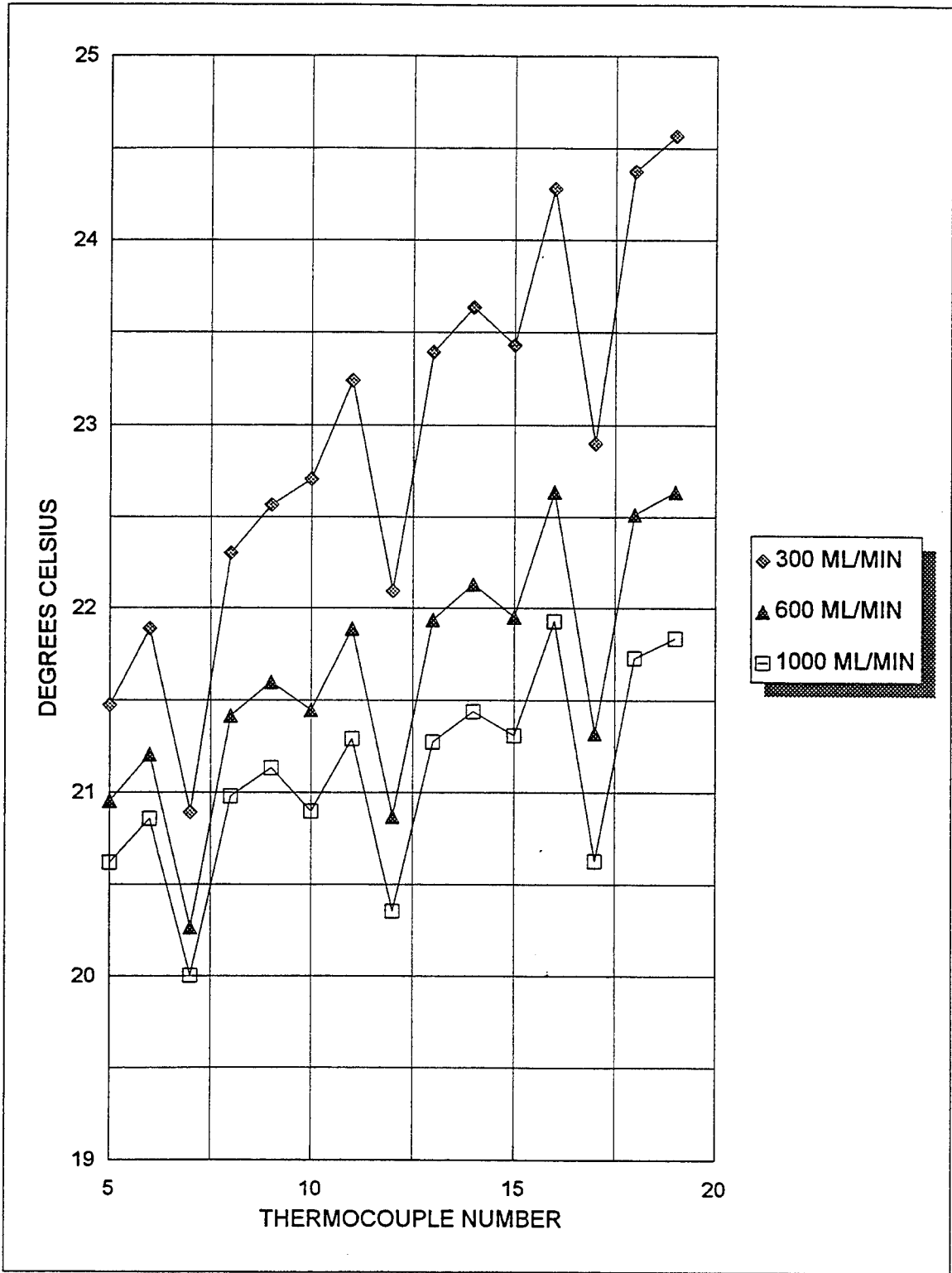

Figure 9. Module surface temperatures at power setting 3.

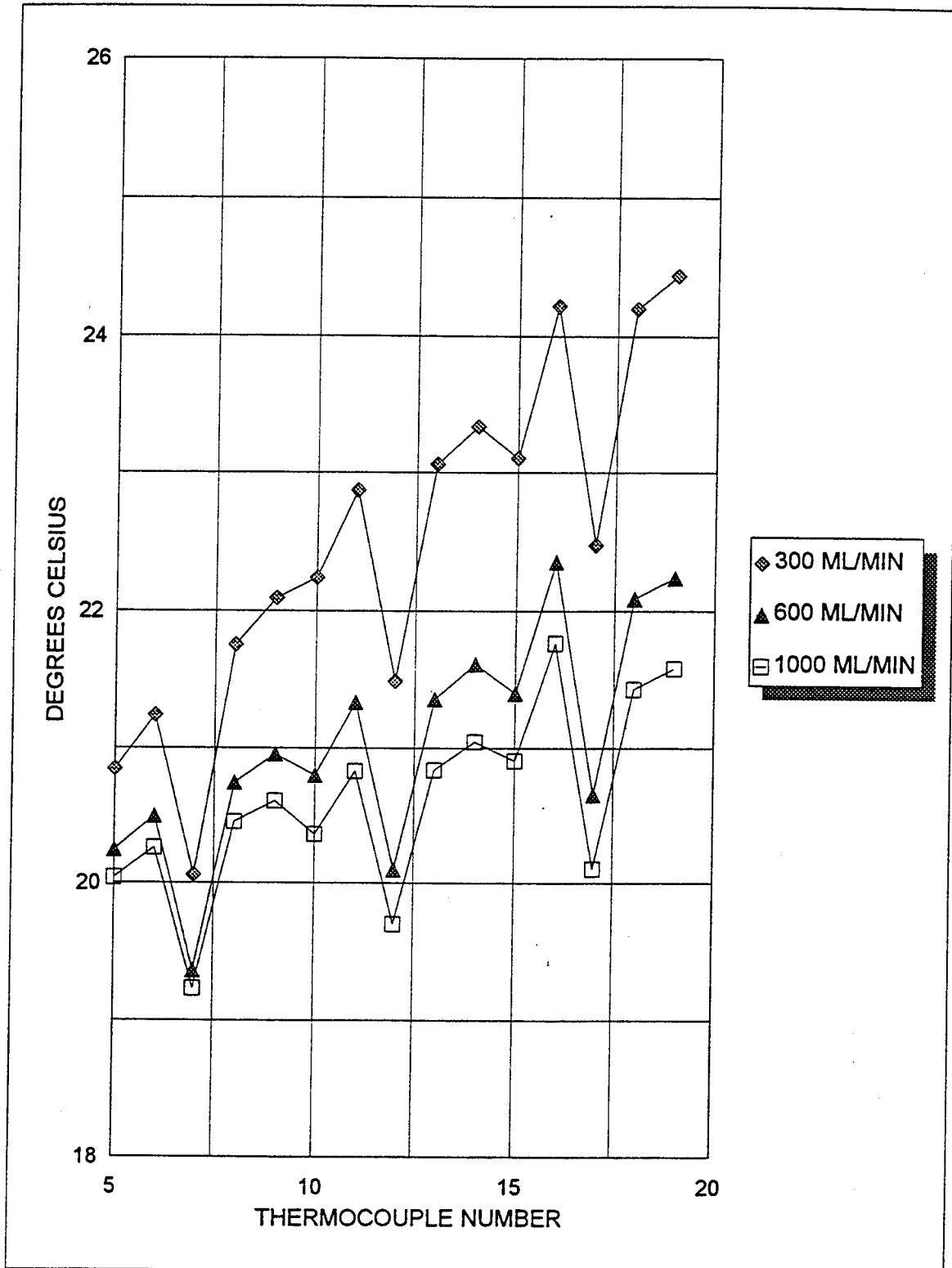

Figure 10. Module surface temperatures at power setting 4.

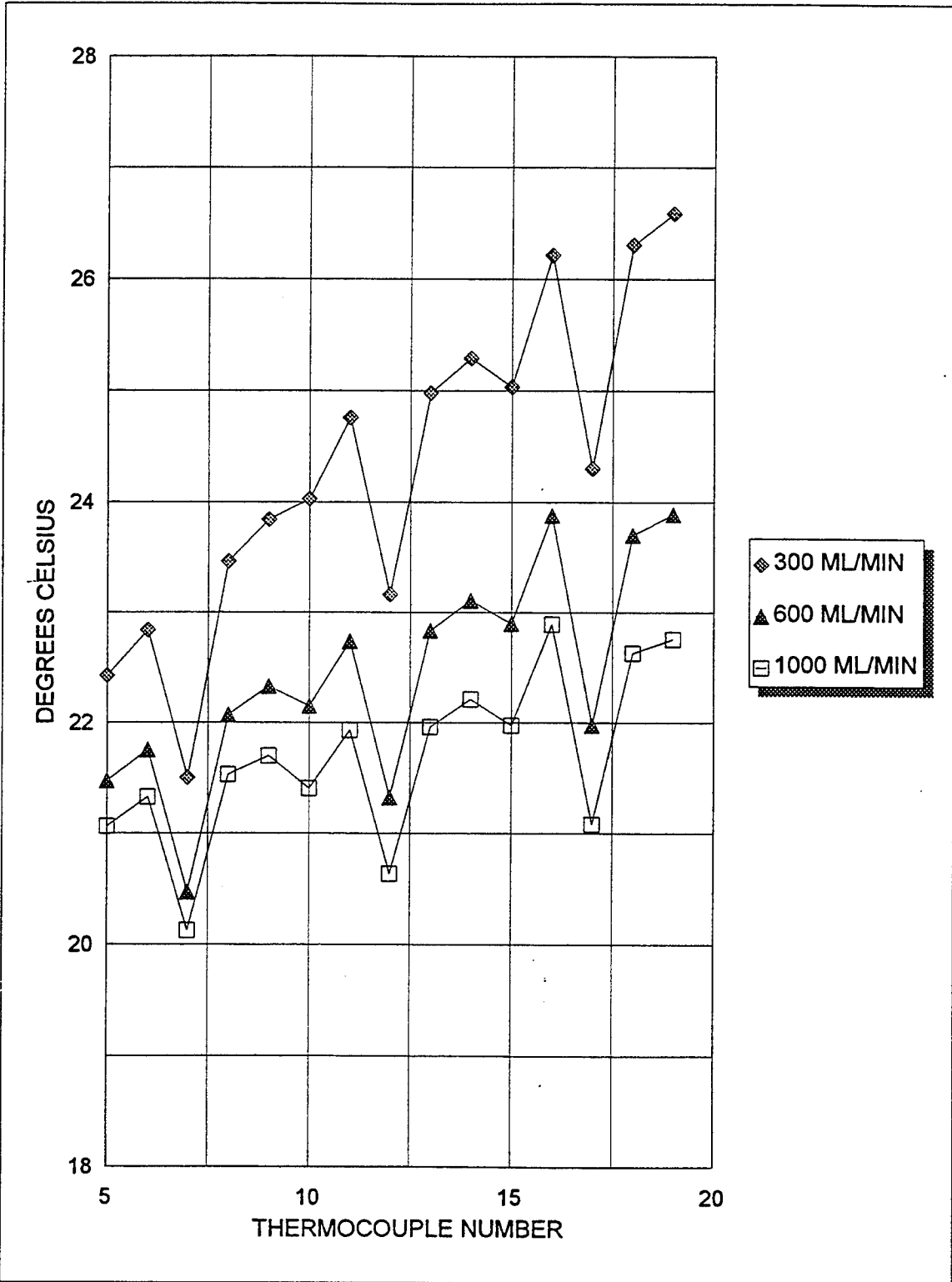

Figure 11. Module surface temperatures at power setting 5.

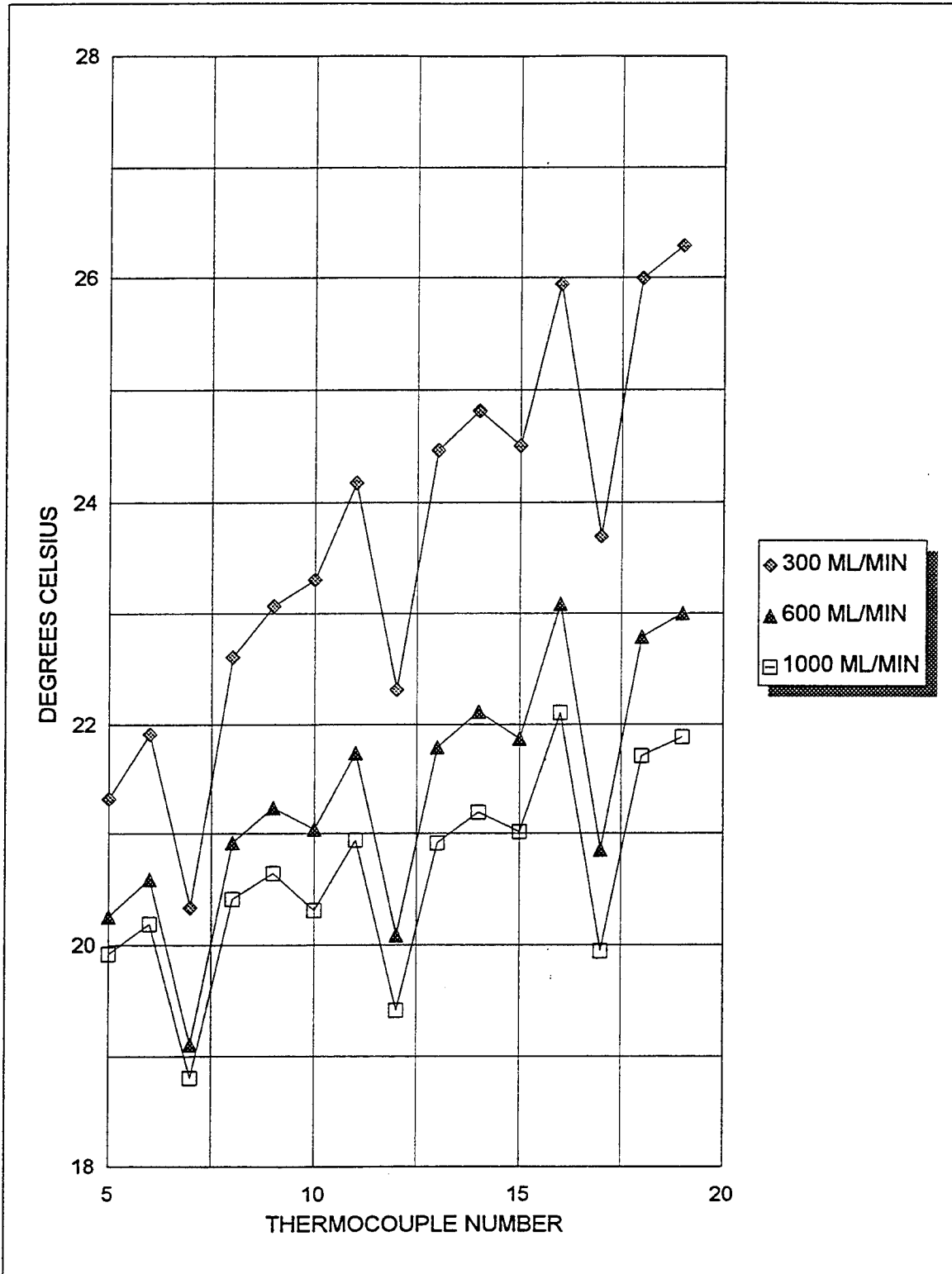

Figure 12. Module surface temperatures at power setting 6.

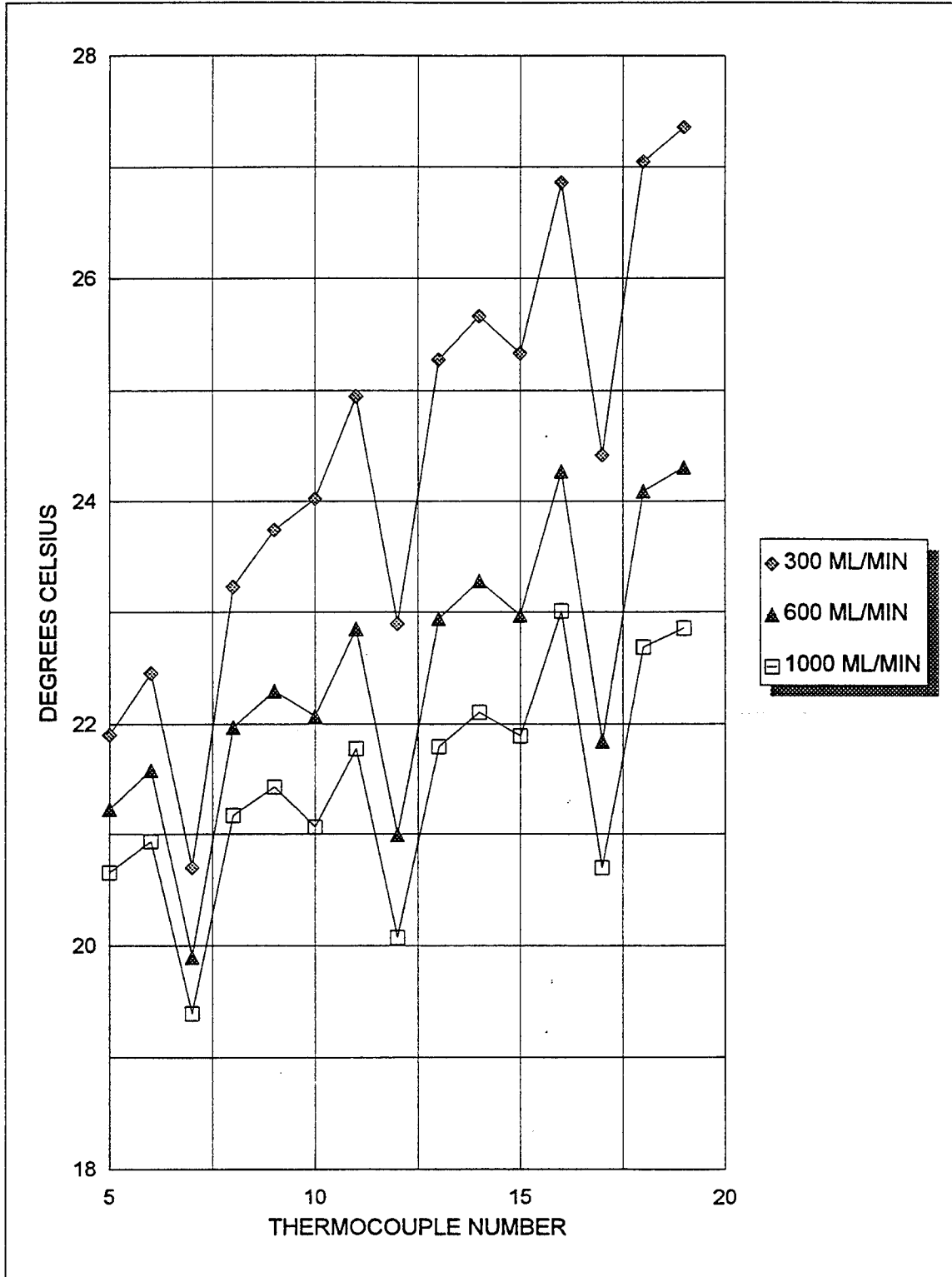

Figure 13. Module surface temperatures at power setting 7.

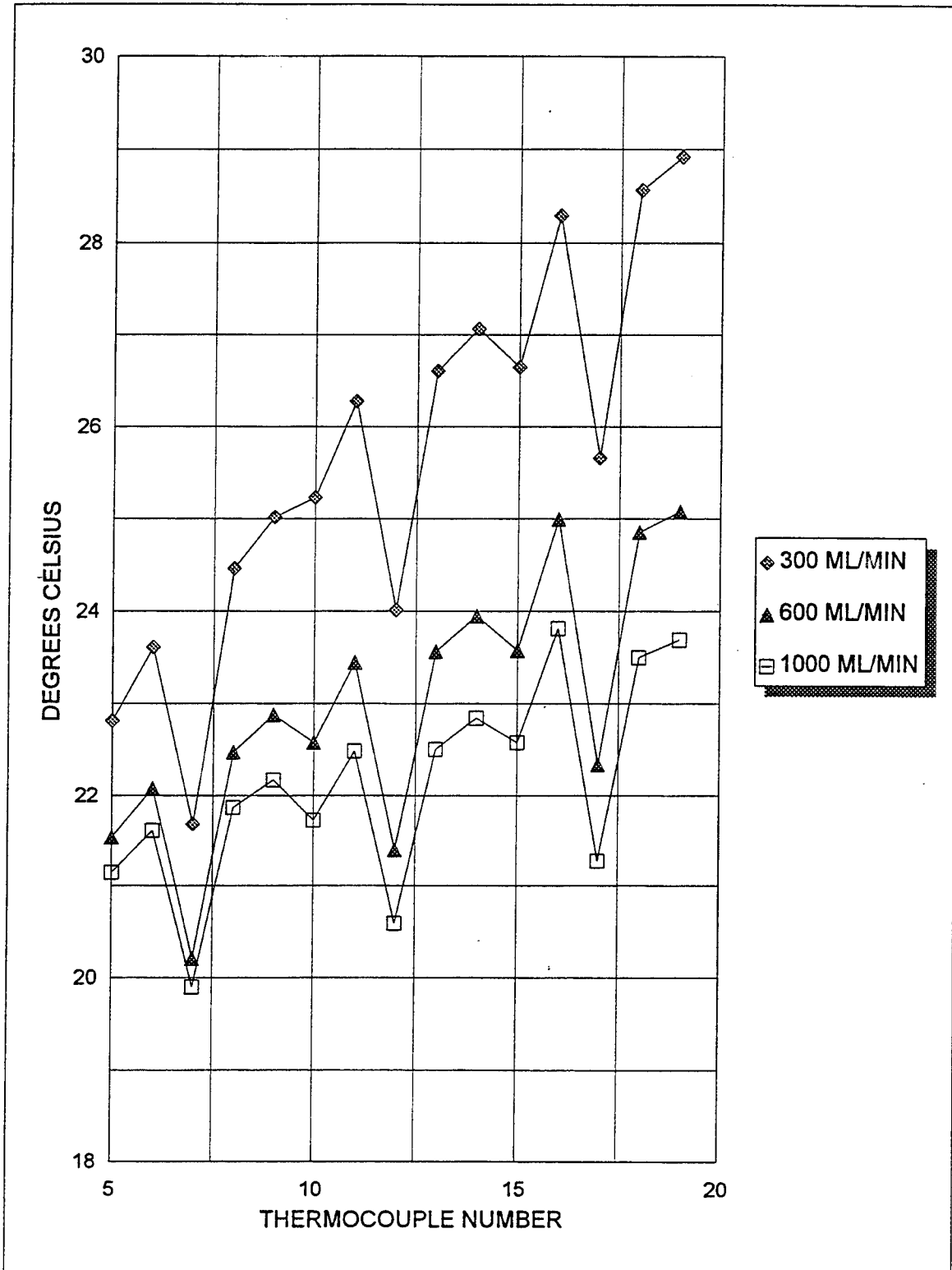

Figure 14. Module surface temperatures at power setting 8.

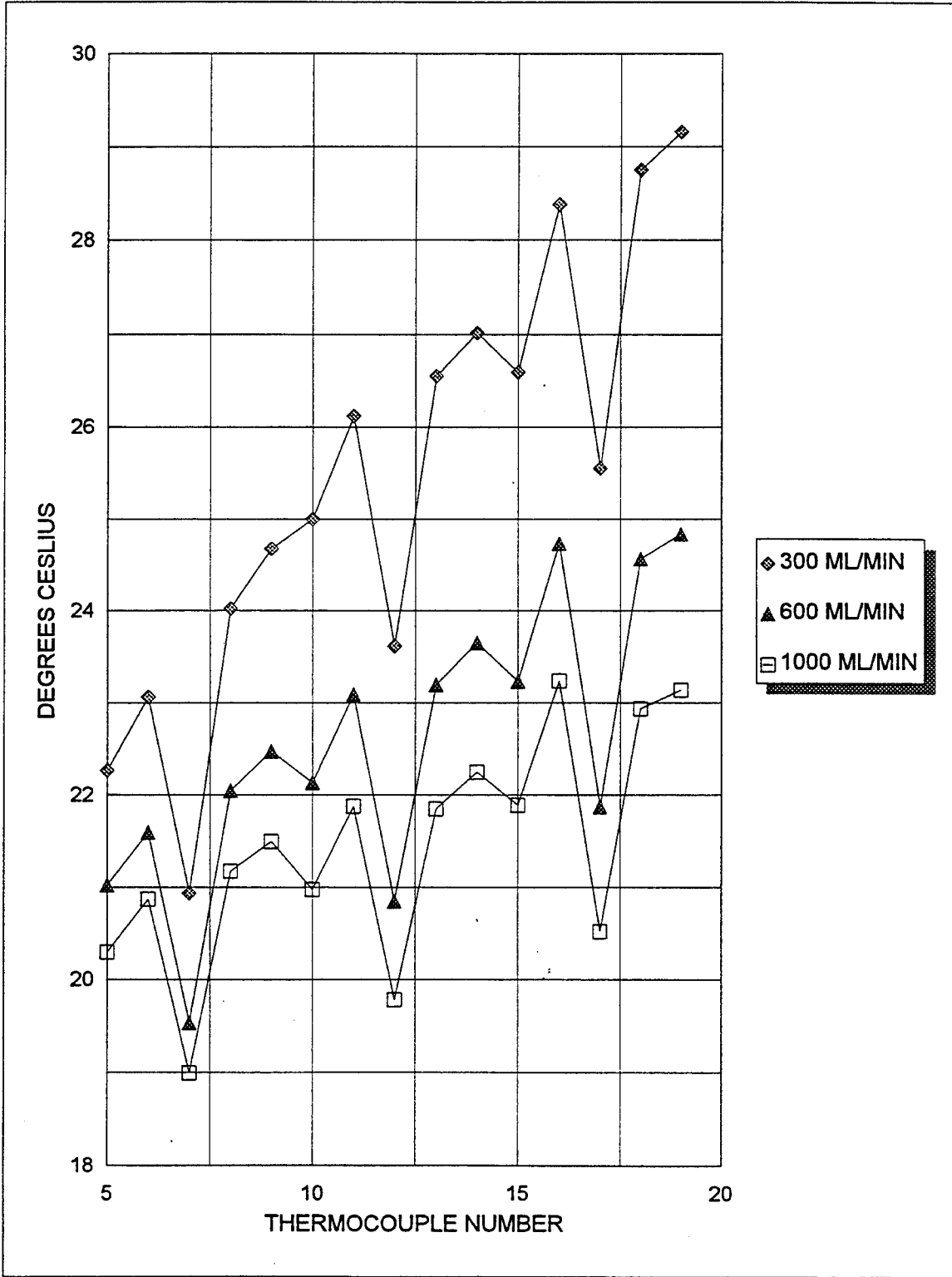

Figure 15. Module surface temperatures at power setting 9.

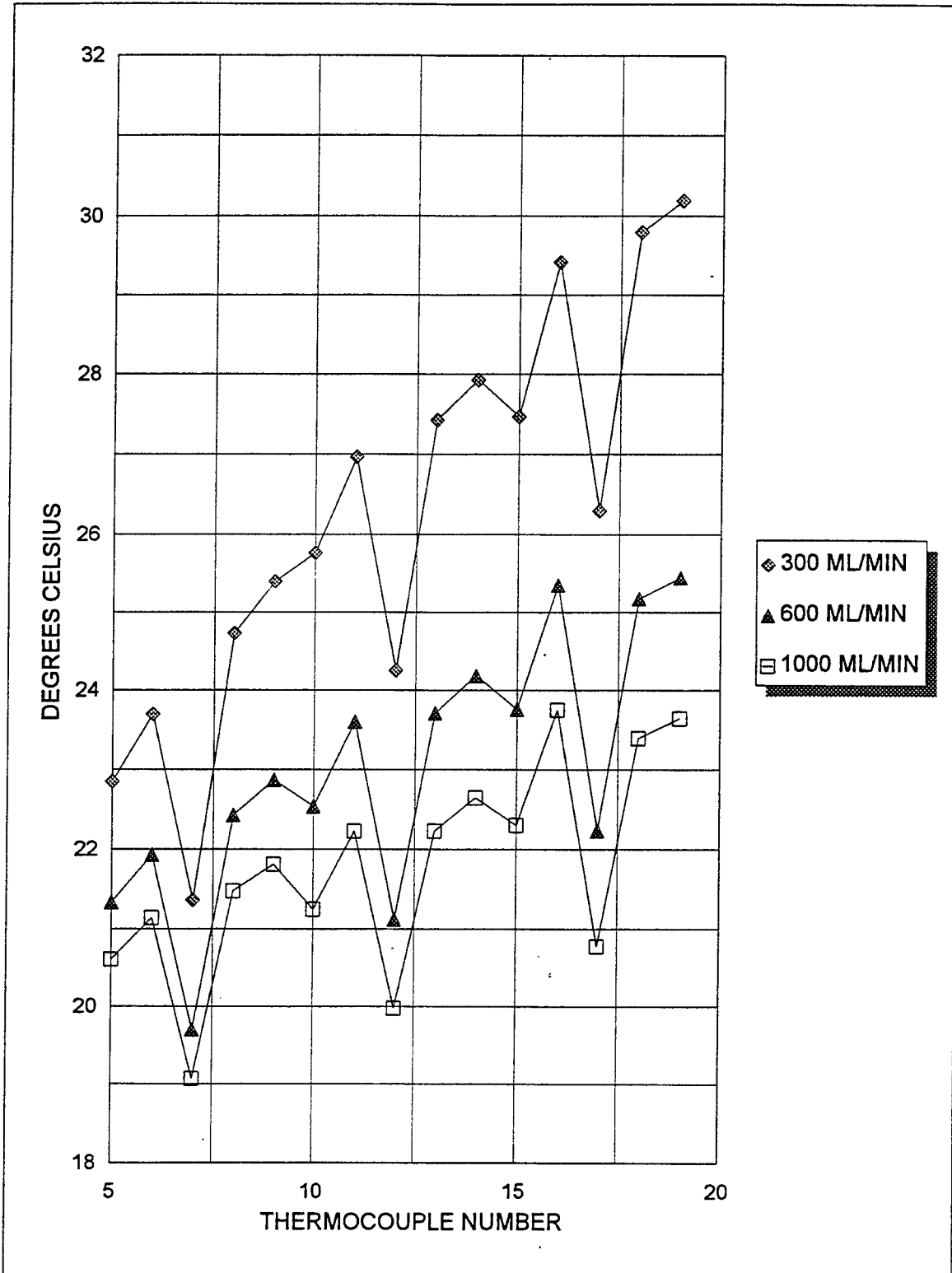

Figure 16. Module surface temperatures at power setting 10.

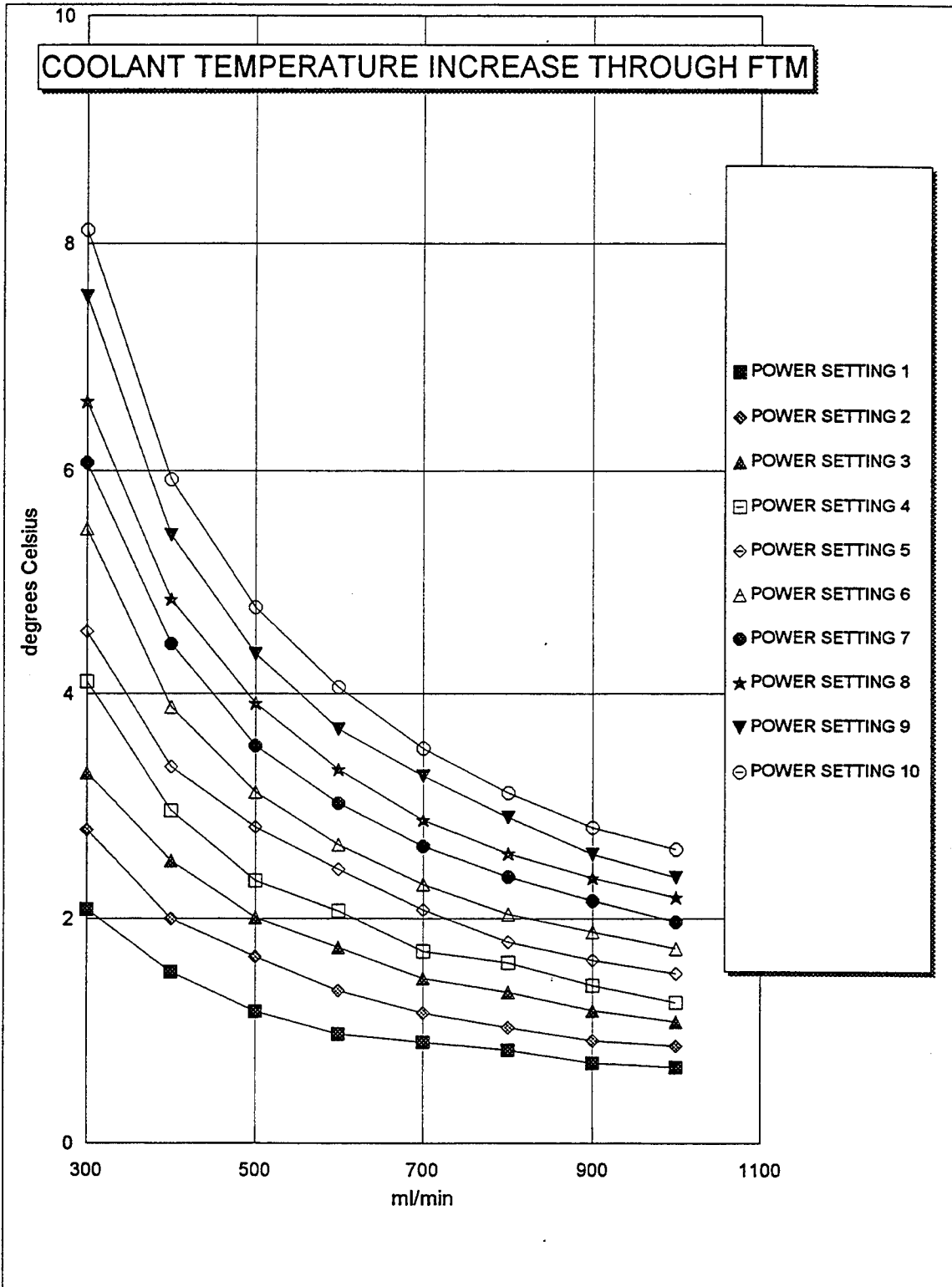

Figure 17. Coolant temperature increase through FTM.

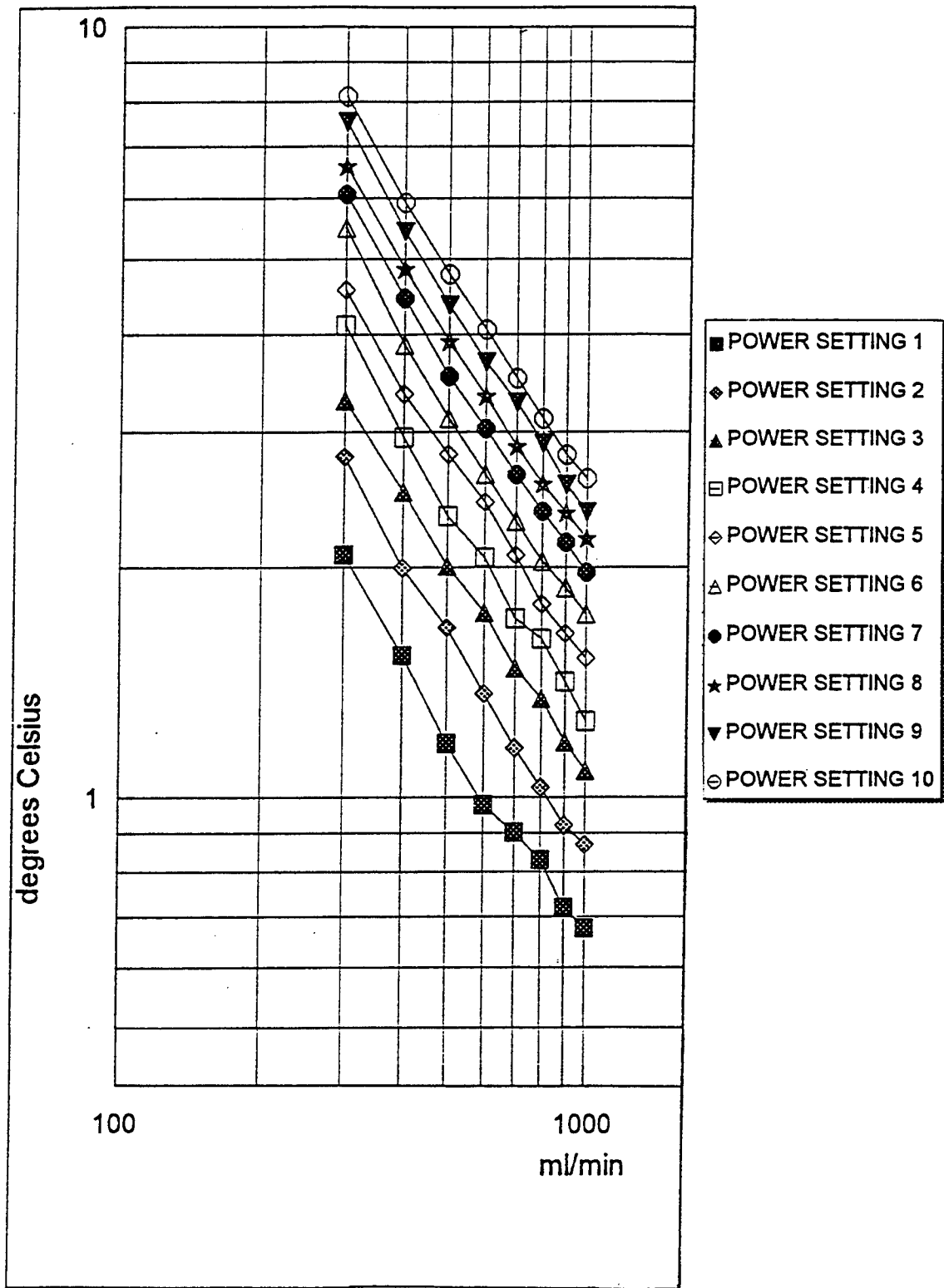

Figure 18. Log-log plot of temperature differentials.

	Flow setting (ml/min)							
	300	400	500	600	700	800	900	1000
	Total Power Input (W)							
	17.43	17.42	17.44	17.42	17.43	17.43	17.43	17.44
	Degrees C							
T(3)avg (inlet)	16.81	16.81	16.77	16.75	16.68	16.61	16.98	16.81
T(4)avg (outlet)	18.89	18.34	17.95	17.73	17.59	17.44	17.70	17.49
delta Tfluid (avg)	2.08	1.53	1.18	0.98	0.90	0.83	0.72	0.68
	Delta T Across Heaters (degrees C)							
HEATER A	0.26	0.23	0.20	0.17	0.15	0.19	0.14	0.16
HEATER B	0.17	0.14	0.13	0.12	0.10	0.09	0.11	0.08
HEATER C	0.30	0.29	0.26	0.26	0.27	0.26	0.26	0.25
HEATER D	0.16	0.16	0.11	0.12	0.10	0.13	0.11	0.10
HEATER E	0.58	0.49	0.50	0.48	0.45	0.44	0.44	0.44
HEATER F	0.08	0.10	0.04	0.05	0.05	0.06	0.06	0.05
	Mid-channel Temperature Drops (degrees C)							
After heater A	0.60	0.59	0.58	0.56	0.52	0.54	0.53	0.53
After heater C	0.69	0.68	0.64	0.64	0.62	0.60	0.58	0.56
After heater E	0.84	0.86	0.86	0.87	0.86	0.83	0.83	0.85
	Coolant Thermophysical Properties							
density (g/ml)	0.7958	0.7961	0.7962	0.7963	0.7964	0.7965	0.7963	0.7964
Cp (J/(gC))	2.199	2.198	2.198	2.197	2.197	2.197	2.198	2.197
	Heat Dissipation							
Qf (W)	18.20	17.85	17.21	17.14	18.37	19.37	18.90	19.83
Qins (W)	0.03	0.02	0.02	0.02	0.01	0.01	0.02	0.02
q"ins (W/m)	1.31	1.06	0.88	0.80	0.42	0.53	0.79	0.66

Table 14. Calculations for power setting 1.

	Flow setting (ml/min)							
	300	400	500	600	700	800	900	1000
	Total Power Input (W)							
	23.23	23.23	23.23	23.24	23.23	23.23	23.23	23.24
	Degrees C							
T(3) avg (inlet)	18.09	18.01	17.92	18	18.01	17.88	17.94	17.79
T(4)avg (outlet)	20.88	20.01	19.58	19.37	19.17	18.91	18.86	18.65
delta Tfluid (avg)	2.79	2.00	1.67	1.36	1.16	1.03	0.92	0.87
	Delta T Across Heaters (degrees C)							
HEATER A	0.28	0.22	0.22	0.18	0.15	0.15	0.15	0.14
HEATER B	0.21	0.17	0.16	0.15	0.11	0.12	0.10	0.11
HEATER C	0.44	0.38	0.36	0.38	0.34	0.33	0.33	0.31
HEATER D	0.17	0.16	0.17	0.16	0.19	0.15	0.14	0.17
HEATER E	0.68	0.62	0.61	0.57	0.54	0.54	0.54	0.53
HEATER F	0.13	0.14	0.09	0.09	0.09	0.08	0.08	0.10
	Mid-channel Temperature Drops (degrees C)							
After heater A	0.77	0.76	0.77	0.72	0.75	0.73	0.71	0.67
After heater C	0.93	0.87	0.85	0.84	0.80	0.77	0.78	0.74
After heater E	1.11	1.10	1.12	1.09	1.07	1.07	1.06	1.05
	Coolant Thermophysical properties							
density(g/ml)	0.7944	0.7948	0.7951	0.7951	0.7952	0.7954	0.7954	0.7955
Cp (J/(gC))	2.204	2.000	2.203	2.202	2.201	2.201	2.201	2.200
	Heat Dissipation							
Qf (W)	24.42	21.19	24.38	23.81	23.69	24.04	24.16	25.38
Qins (W)	0.04	0.03	0.03	0.02	0.02	0.02	0.02	0.02
q"ins (W/m)	1.60	1.24	1.13	1.00	0.96	0.96	0.88	0.71

Table 15. Calculations for power setting 2.

	Flow setting (ml/min)							
	300	400	500	600	700	800	900	1000
	Total Power Input (W)							
	29.03	29.01	29.01	29.01	29.01	29.01	29.01	29.01
	Degrees C							
T(3)avg (inlet)	19.73	19.7	19.75	19.68	19.61	19.55	19.58	19.69
T(4) avg (outlet)	23.02	22.21	21.75	21.43	21.08	20.89	20.76	20.77
deltaTfluid (avg)	3.3	2.51	2.01	1.74	1.47	1.35	1.18	1.08
	Delta T Across Heaters (degrees C)							
HEATER A	0.42	0.36	0.31	0.25	0.26	0.20	0.20	0.24
HEATER B	0.27	0.23	0.17	0.18	0.16	0.16	0.12	0.15
HEATER C	0.53	0.48	0.44	0.44	0.44	0.39	0.39	0.40
HEATER D	0.24	0.21	0.19	0.19	0.18	0.19	0.18	0.17
HEATER E	0.85	0.78	0.75	0.69	0.66	0.68	0.64	0.62
HEATER F	0.19	0.14	0.11	0.12	0.10	0.12	0.07	0.11
	Mid-channel Temperature Drops (degrees C)							
After heater A	1.00	1.02	0.98	0.94	0.92	0.88	0.86	0.85
After heater C	1.15	1.09	1.06	1.02	1.01	0.95	0.95	0.94
After heater E	1.38	1.38	1.36	1.32	1.35	1.34	1.33	1.30
	Coolant Thermophysical Properties							
density (g/ml)	0.7928	0.7932	0.7934	0.7935	0.7937	0.7938	0.7939	0.7938
Cp (J/(gC))	2.210	2.208	2.208	2.207	2.207	2.206	2.206	2.206
	Heat Dissipation							
Qf (W)	28.91	29.31	29.34	30.47	30.04	31.52	31.00	31.52
Qins (W)	0.05	0.03	0.03	0.03	0.02	0.02	0.02	0.02
q"ins (W/m)	2.10	1.46	1.23	1.16	0.97	0.93	0.79	0.70

Table 16. Calculations for power setting 3.

	Flow setting (ml/min)							
	300	400	500	600	700	800	900	1000
	Total Power Input (W)							
	34.82	34.84	34.82	34.84	34.85	34.85	34.82	34.80
	Degrees C							
T(3)avg (inlet)	18.57	18.56	18.71	18.6	18.92	18.83	18.85	18.89
T(4)avg (outlet)	22.68	21.52	21.04	20.67	20.63	20.44	20.26	20.15
delta Tfluid (avg)	4.11	2.96	2.33	2.06	1.71	1.61	1.41	1.26
	Delta T Across Heaters (degrees C)							
HEATER A	0.40	0.34	0.25	0.25	0.21	0.22	0.24	0.22
HEATER B	0.34	0.29	0.23	0.21	0.20	0.21	0.16	0.15
HEATER C	0.64	0.59	0.57	0.54	0.50	0.50	0.49	0.47
HEATER D	0.27	0.27	0.25	0.26	0.23	0.25	0.20	0.21
HEATER E	1.12	1.02	0.96	0.95	0.89	0.89	0.86	0.86
HEATER F	0.24	0.20	0.17	0.15	0.16	0.15	0.15	0.15
	Mid-channel Temperature Drops (degrees C)							
After heater A	1.19	1.18	1.15	1.13	1.10	1.11	1.03	1.03
After heater C	1.38	1.32	1.29	1.24	1.18	1.16	1.14	1.13
After heater E	1.75	1.73	1.72	1.70	1.67	1.67	1.65	1.66
	Coolant Thermophysical Properties							
density (g/ml)	0.7935	0.7940	0.7941	0.7943	0.7942	0.7943	0.7944	0.7944
Cp (J/(gC))	2.207	2.206	2.205	2.205	2.205	2.205	2.204	2.204
	Heat Dissipation							
Qf (W)	35.99	34.56	34.00	36.08	34.94	37.60	37.03	36.77
Qins (W)	0.06	0.06	0.05	0.04	0.04	0.04	0.04	0.03
q"ins (W/m)	2.84	2.54	2.34	1.96	1.91	1.80	1.81	1.56

Table 17. Calculations for power setting 4.

	Flow setting (ml/min)							
	300	400	500	600	700	800	900	1000
	Total Power Input (W)							
	40.65	40.65	40.65	40.65	40.65	40.65	40.65	40.65
	Degrees C							
T(3)avg (inlet)	19.90	19.81	19.69	19.62	19.72	19.72	19.56	19.60
T(4)avg (outlet)	24.46	23.16	22.50	22.05	21.79	21.51	21.20	21.12
delta Tfluid (avg)	4.56	3.35	2.81	2.43	2.08	1.79	1.64	1.52
	Delta T Across Heaters (degrees C)							
Heater A	0.42	0.36	0.33	0.28	0.31	0.30	0.29	0.27
Heater B	0.38	0.32	0.26	0.26	0.25	0.21	0.19	0.17
Heater C	0.73	0.65	0.63	0.59	0.58	0.61	0.57	0.53
Heater D	0.31	0.30	0.30	0.27	0.26	0.27	0.23	0.25
Heater E	1.18	1.10	1.04	0.98	0.96	0.92	0.90	0.92
Heater F	0.28	0.18	0.18	0.19	0.15	0.13	0.13	0.12
	Mid-channel Temperature Drops (degrees C)							
After heater A	1.34	1.37	1.35	1.29	1.29	1.27	1.24	1.20
After heater C	1.60	1.54	1.48	1.42	1.40	1.38	1.35	1.30
After heater E	1.91	1.95	1.93	1.90	1.87	1.87	1.80	1.81
	Coolant Thermophysical Properties							
density (g/ml)	0.7921	0.7927	0.7931	0.7933	0.7934	0.7935	0.7937	0.7937
Cp (J/(gC))	2.212	2.210	2.209	2.208	2.208	2.207	2.207	2.207
	Heat Dissipation							
Qf (W)	39.95	39.13	41.03	42.56	42.51	41.80	43.09	44.38
Qins (W)	0.06	0.05	0.04	0.04	0.04	0.03	0.03	0.03
q"ins (W/m)	2.62	2.21	1.96	1.73	1.70	1.53	1.46	1.36

Table 18. Calculations for power setting 5.

	Flow setting (ml/min)							
	300	400	500	600	700	800	900	1000
	Total Power Input (W)							
	46.42	46.43	46.43	46.45	46.46	46.46	46.43	46.44
	Degrees C							
T(3)avg (inlet)	18.38	18.41	18.42	18.35	18.45	18.46	18.36	18.15
T(4)avg (outlet)	23.86	22.29	21.55	21.00	20.75	20.50	20.24	19.88
deltaTfluid(avg)	5.48	3.88	3.12	2.65	2.30	2.04	1.88	1.74
	Delta T Across Heaters (degrees C)							
HEATER A	0.59	0.44	0.39	0.33	0.32	0.34	0.26	0.27
HEATER B	0.46	0.39	0.33	0.32	0.29	0.25	0.25	0.23
HEATER C	0.88	0.76	0.74	0.70	0.68	0.68	0.64	0.63
HEATER D	0.35	0.35	0.34	0.32	0.30	0.30	0.27	0.28
HEATER E	1.43	1.32	1.26	1.22	1.20	1.14	1.16	1.09
HEATER F	0.29	0.27	0.25	0.21	0.19	0.17	0.20	0.17
	Mid-channel Temperature Drops (degrees C)							
After heater A	1.58	1.56	1.54	1.48	1.47	1.43	1.41	1.38
After heater C	1.87	1.78	1.73	1.65	1.62	1.59	1.54	1.52
After heater E	2.25	2.27	2.24	2.24	2.23	2.19	2.20	2.16
	Coolant Thermophysical Properties							
density (g/ml)	0.7930	0.7937	0.7940	0.7943	0.7943	0.7944	0.7946	0.7948
Cp (J/(gC))	2.209	2.207	2.206	2.205	2.204	2.204	2.204	2.203
	Heat Dissipation							
Qf (W)	48.03	45.31	45.59	46.42	46.98	47.53	49.45	50.68
Qins (W)	0.07	0.07	0.06	0.05	0.05	0.05	0.05	0.04
q"ins (W/m)	3.31	3.30	2.76	2.41	2.19	2.40	2.34	1.83

Table 19. Calculations for power setting 6.

	Flow setting (ml/min)							
	300	400	500	600	700	800	900	1000
	Total Power Input (W)							
	52.26	52.26	52.27	52.24	52.25	52.25	52.28	52.26
	Degrees C							
T(3)avg (inlet)	18.54	18.85	18.93	18.94	19.04	18.97	18.77	18.66
T(4)avg (outlet)	24.61	23.30	22.47	21.96	21.68	21.34	20.92	20.63
delta Tfluid (avg)	6.07	4.45	3.54	3.02	2.64	2.37	2.16	1.97
	Delta T Across Heaters (degrees C)							
HEATER A	0.55	0.47	0.38	0.36	0.41	0.33	0.34	0.28
HEATER B	0.51	0.42	0.36	0.33	0.30	0.28	0.27	0.26
HEATER C	0.92	0.87	0.84	0.78	0.76	0.73	0.74	0.71
HEATER D	0.39	0.38	0.37	0.34	0.35	0.31	0.34	0.31
HEATER E	1.53	1.40	1.35	1.31	1.20	1.19	1.22	1.12
HEATER F	0.31	0.26	0.22	0.22	0.22	0.20	0.19	0.17
	Mid-channel Temperature Drops (degrees C)							
After heater A	1.76	1.77	1.71	1.69	1.68	1.61	1.54	1.54
After heater C	2.05	1.99	1.91	1.86	1.81	1.78	1.68	1.70
After heater E	2.44	2.45	2.46	2.43	2.39	2.35	2.37	2.32
	Coolant Thermophysical Properties							
density (g/ml)	0.7927	0.7931	0.7934	0.7936	0.7937	0.7939	0.7941	0.7943
Cp (J/(gC))	2.210	2.209	2.208	2.207	2.207	2.206	2.205	2.205
	Heat Dissipation							
Qf (W)	53.19	51.97	51.68	52.96	53.97	55.25	56.68	57.42
Qins (W)	0.10	0.08	0.08	0.07	0.04	0.04	0.05	0.04
q"ins (W/m)	4.72	3.80	3.44	3.03	1.74	1.67	2.36	1.63

Table 20. Calculations for power setting 7.

	Flow settings (ml/min)							
	300	400	500	600	700	800	900	1000
	<b>Total Power Input (W)</b>							
	58.06	58.06	58.07	58.06	58.06	58.06	58.06	58.05
	<b>Degrees C</b>							
T(3)avg (inlet)	19.32	19.29	19.30	19.28	19.28	19.31	19.21	19.11
T(4)avg (outlet)	25.92	24.14	23.22	22.61	22.15	21.88	21.56	21.29
delta Tfluid (avg)	6.61	4.85	3.92	3.33	2.87	2.57	2.36	2.18
	<b>Delta T Across Heaters (degrees C)</b>							
HEATER A	0.79	0.68	0.60	0.55	0.52	0.49	0.47	0.46
HEATER B	0.55	0.47	0.43	0.41	0.38	0.33	0.32	0.30
HEATER C	1.05	0.98	0.92	0.87	0.84	0.84	0.80	0.76
HEATER D	0.46	0.42	0.41	0.39	0.39	0.35	0.35	0.34
HEATER E	1.64	1.52	1.44	1.41	1.34	1.30	1.28	1.23
HEATER F	0.36	0.29	0.26	0.22	0.20	0.20	0.19	0.19
	<b>Mid-channel Temperature Drops (degrees C)</b>							
After heater A	1.93	1.95	1.93	1.87	1.84	1.81	1.76	1.71
After heater C	2.27	2.21	2.13	2.06	1.99	1.96	1.92	1.90
After heater E	2.64	2.67	2.66	2.66	2.61	2.59	2.60	2.54
	<b>Coolant Thermophysical Properties</b>							
density (g/ml)	0.7918	0.7925	0.7929	0.7932	0.7934	0.7935	0.7937	0.7938
Cp (J/(gC))	2.213	2.211	2.209	2.208	2.208	2.207	2.207	2.206
	<b>Heat Dissipation</b>							
Qf (W)	57.87	56.61	57.16	58.30	58.72	59.99	61.90	63.71
Qins (W)	0.11	0.09	0.08	0.08	0.07	0.07	0.06	0.06
q"ins (W/m)	4.89	4.23	3.72	3.49	3.31	3.08	2.93	2.58

Table 21. Calculations for power setting 8.

	Flow setting (ml/min)							
	300	400	500	600	700	800	900	1000
	Total Power Input (W)							
	63.87	63.84	63.85	63.85	63.86	63.86	63.86	63.86
	Degrees C							
T(3) avg (inlet)	18.31	18.33	18.36	18.34	18.22	18.24	18.12	18.21
T(4)avg (outlet)	25.84	23.75	22.73	22.02	21.50	21.14	20.69	20.57
deltaTfluid(avg)	7.53	5.43	4.36	3.68	3.27	2.90	2.57	2.36
	Delta T Across Heaters (degrees C)							
HEATER A	0.80	0.68	0.67	0.57	0.60	0.63	0.56	0.58
HEATER B	0.65	0.54	0.44	0.43	0.38	0.34	0.32	0.32
HEATER C	1.13	1.05	1.00	0.96	0.94	0.92	0.88	0.90
HEATER D	0.47	0.49	0.46	0.45	0.42	0.40	0.39	0.40
HEATER E	1.80	1.63	1.57	1.51	1.45	1.44	1.38	1.35
HEATER F	0.40	0.32	0.27	0.27	0.20	0.23	0.22	0.20
	Mid-Channel Temperature Drops (degrees C)							
After heater A	2.13	2.13	2.14	2.06	2.02	1.99	1.92	1.88
After heater C	2.51	2.42	2.33	2.25	2.18	2.13	2.11	2.10
After heater E	2.83	2.89	2.87	2.87	2.83	2.80	2.77	2.72
	Coolant Thermophysical Properties							
density (g/ml)	0.7922	0.7931	0.7935	0.7938	0.7941	0.7943	0.7945	0.7945
Cp (J/(gC))	2.212	2.209	2.207	2.206	2.205	2.205	2.204	2.204
	Heat Dissipation							
Qf (W)	65.99	63.36	63.64	64.49	66.86	67.72	67.43	68.90
Qins (W)	0.12	0.09	0.08	0.08	0.08	0.07	0.07	0.08
q"ins (W/m)	5.38	4.09	3.70	3.55	3.41	3.30	3.31	3.48

Table 22. Calculations for power setting 9.

	Flow setting (ml/min)							
	300	400	500	600	700	800	900	1000
	Total Power Input (W)							
	69.65	69.67	69.67	69.67	69.68	69.67	69.71	69.67
	Degrees C							
T(3)avg (inlet)	18.49	18.41	18.33	18.33	18.00	18.20	18.12	18.06
T(4)avg (outlet)	26.60	24.33	23.10	22.39	21.52	21.31	20.93	20.67
delta Tfluid(avg)	8.12	5.92	4.77	4.06	3.51	3.12	2.80	2.61
	Delta T Across Heaters (degrees C)							
HEATER A	0.84	0.77	0.68	0.60	0.48	0.53	0.53	0.53
HEATER B	0.67	0.57	0.48	0.44	0.47	0.38	0.38	0.34
HEATER C	1.21	1.17	1.13	1.06	1.00	0.99	0.97	0.99
HEATER D	0.50	0.49	0.48	0.47	0.47	0.47	0.44	0.42
HEATER E	1.95	1.79	1.70	1.59	1.60	1.52	1.50	1.45
HEATER F	0.39	0.33	0.27	0.27	0.23	0.27	0.23	0.25
	Mid-channel Temperature Drops (degrees C)							
After heater A	2.33	2.33	2.30	2.24	2.18	2.19	2.10	2.07
After heater C	2.72	2.64	2.57	2.49	2.39	2.33	2.30	2.26
After heater E	3.12	3.14	3.15	3.12	3.12	3.06	3.01	2.98
	Coolant Thermophysical Properties							
density (g/ml)	0.7918	0.7928	0.7934	0.7937	0.7942	0.7942	0.7944	0.7945
Cp (J/(gC))	2.213	2.210	2.208	2.207	2.205	2.205	2.204	2.204
	Heat Dissipation							
Qf (W)	71.14	69.15	69.64	71.12	71.71	72.85	73.54	76.17
Qins (W)	0.12	0.10	0.09	0.08	0.06	0.08	0.07	0.07
q"ins (W/m)	5.39	4.61	4.24	3.82	2.50	3.49	3.39	2.97

Table 23. Calculations for power setting 10.

## Heat Absorbed by Fluid ( $Q_f$ )

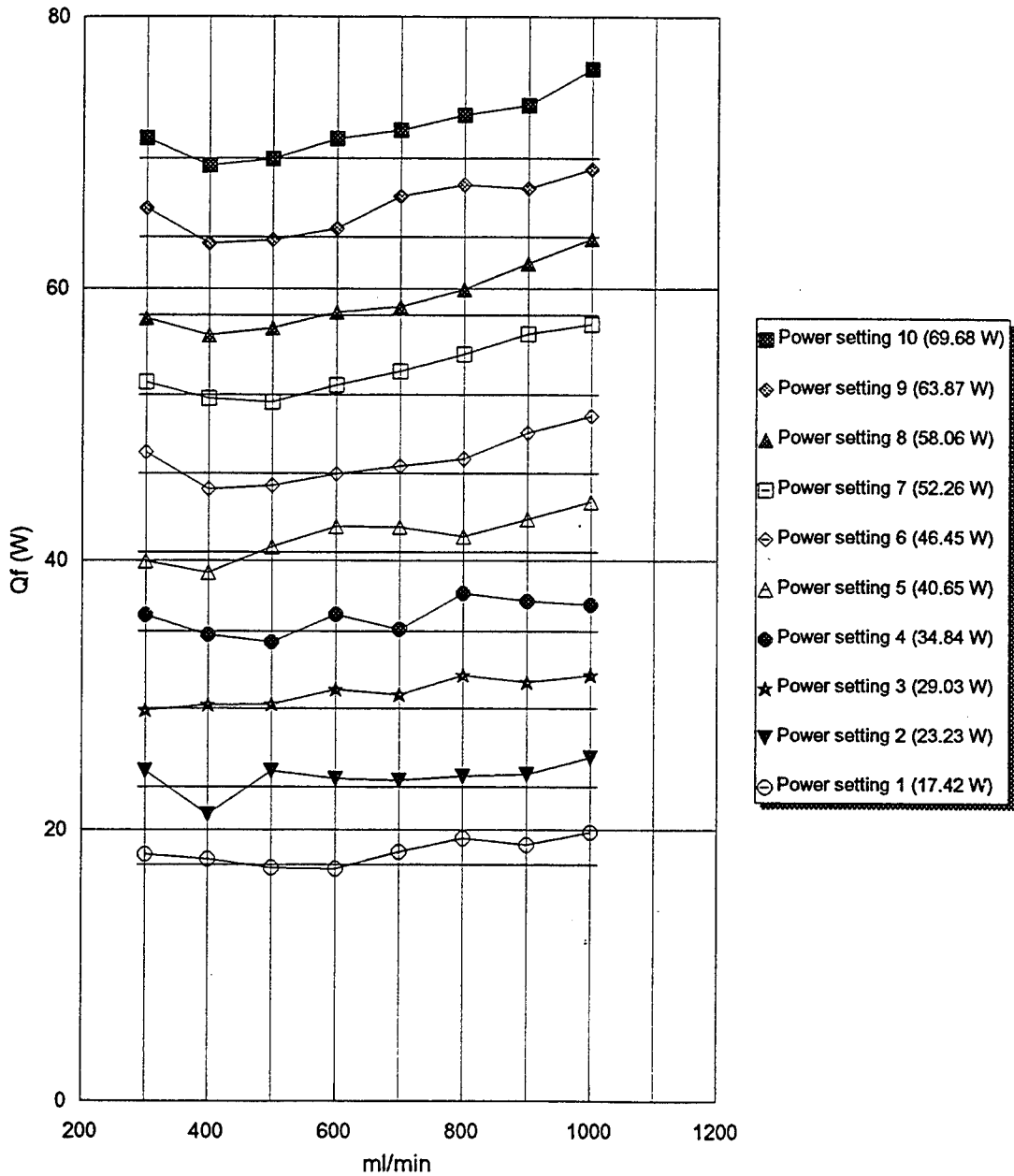
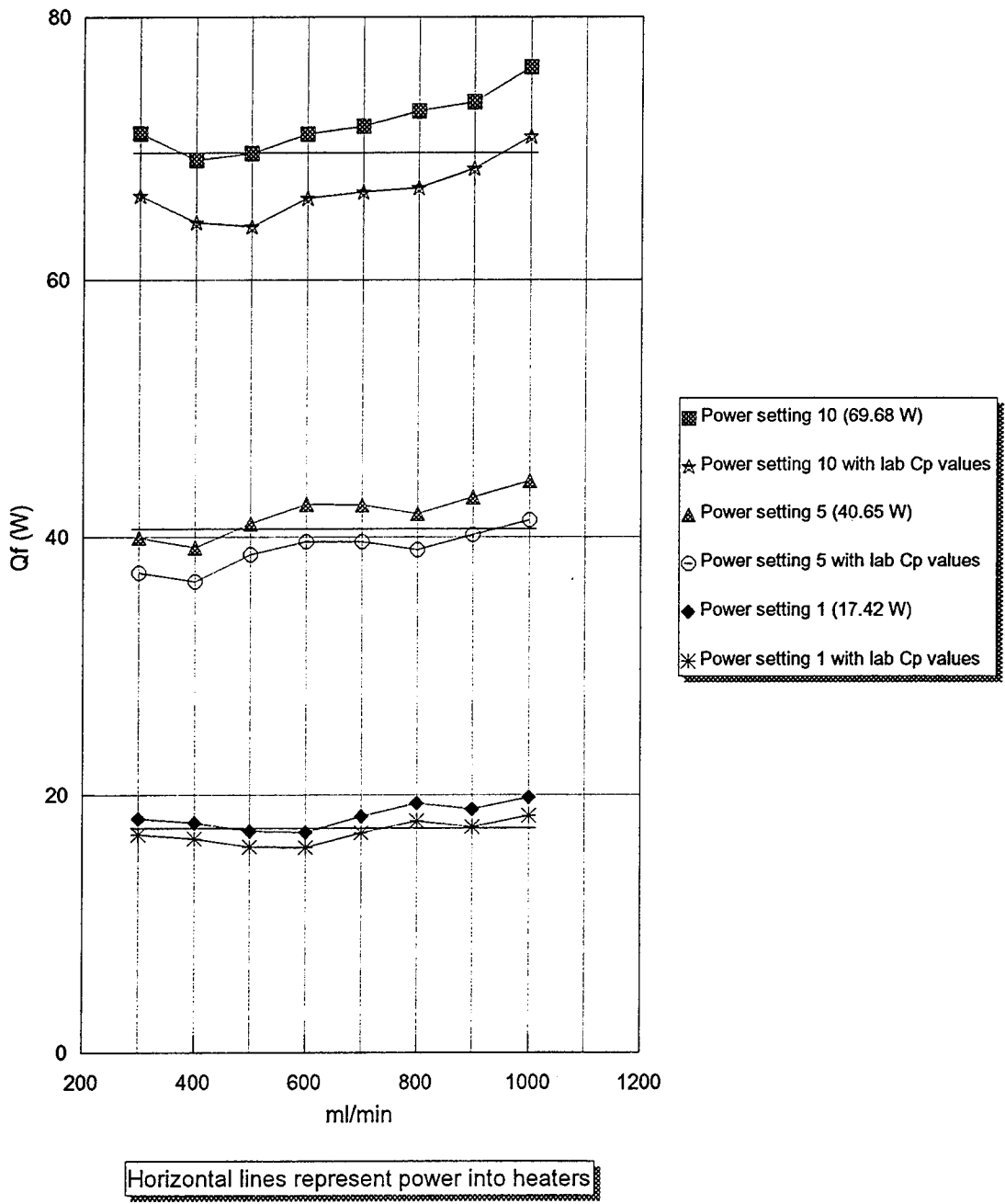

Figure 19. Heat absorbed by fluid ( $Q_f$ ).

## Heat Absorbed by Fluid ( $Q_f$ )

(Computed with Manufacturer's Cp values and Lab Data)



**Figure 20.** Revised  $Q_f$  calculations based on lab data.

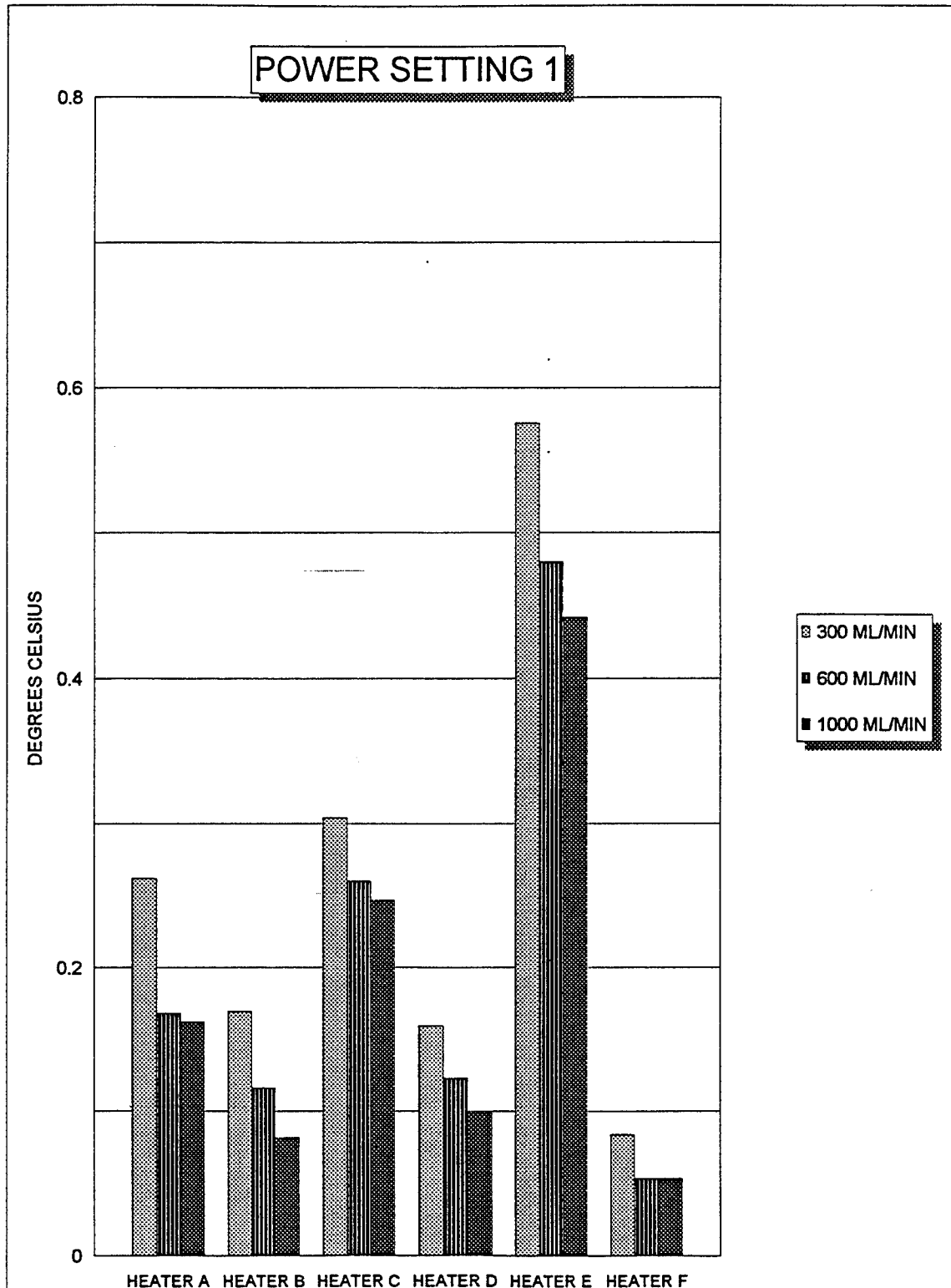

Figure 21. Temp rise across heaters at power setting 1.

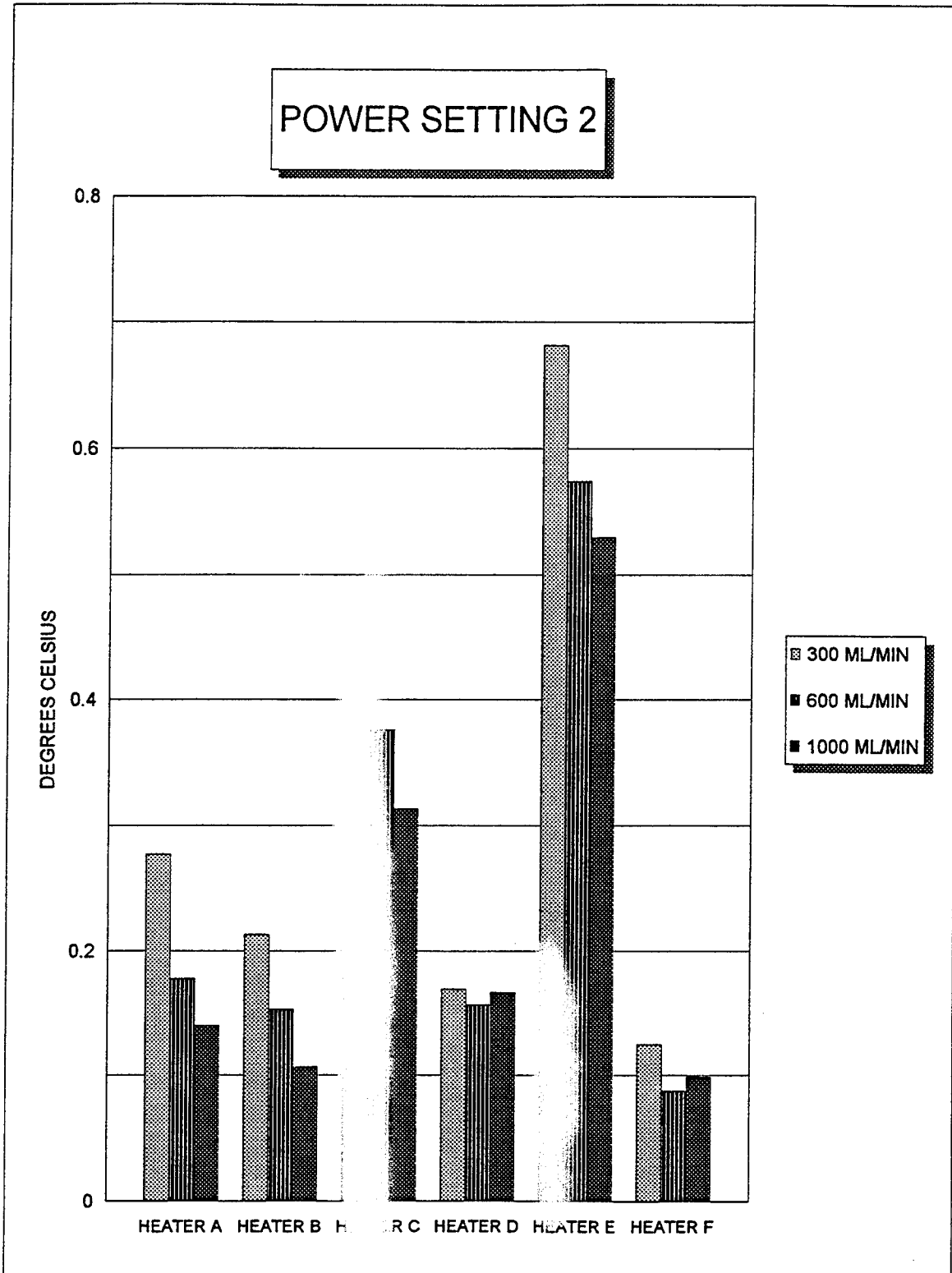

Figure 22. Temp rise across heaters at power setting 2.

### POWER SETTING 3

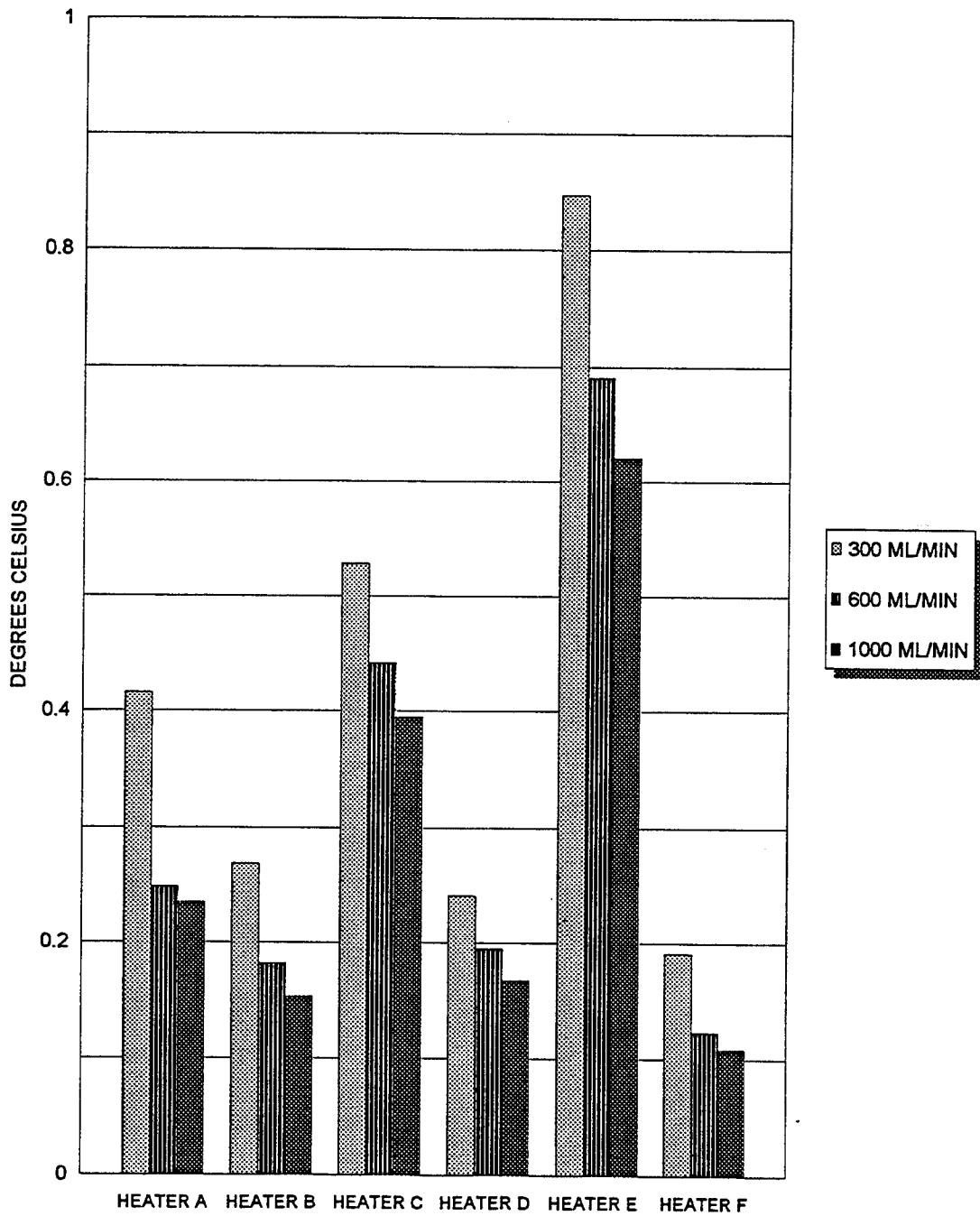

Figure 23. Temp rise across heaters at power setting 3.

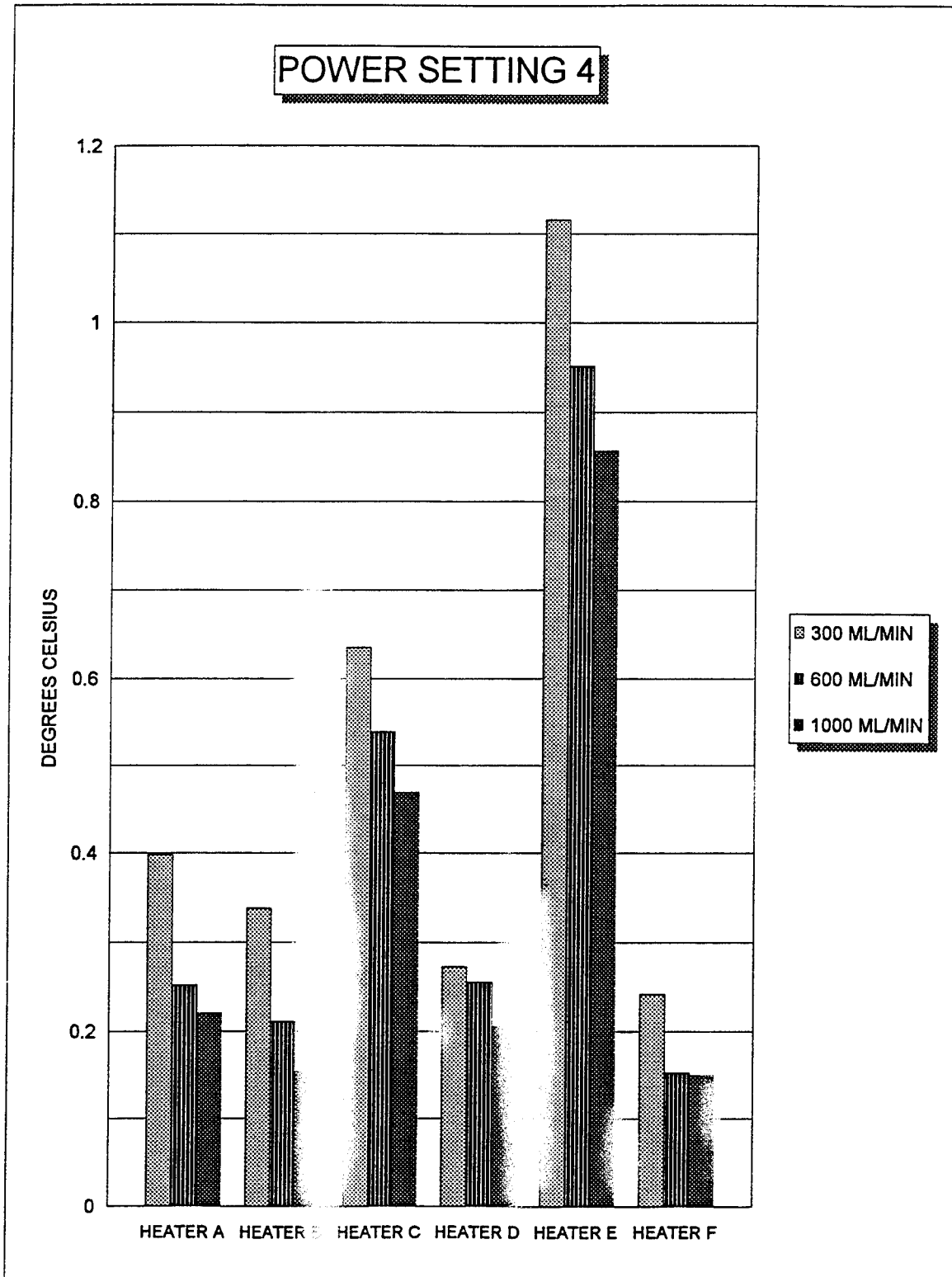

Figure 24. Temp rise across heaters at power setting 4.

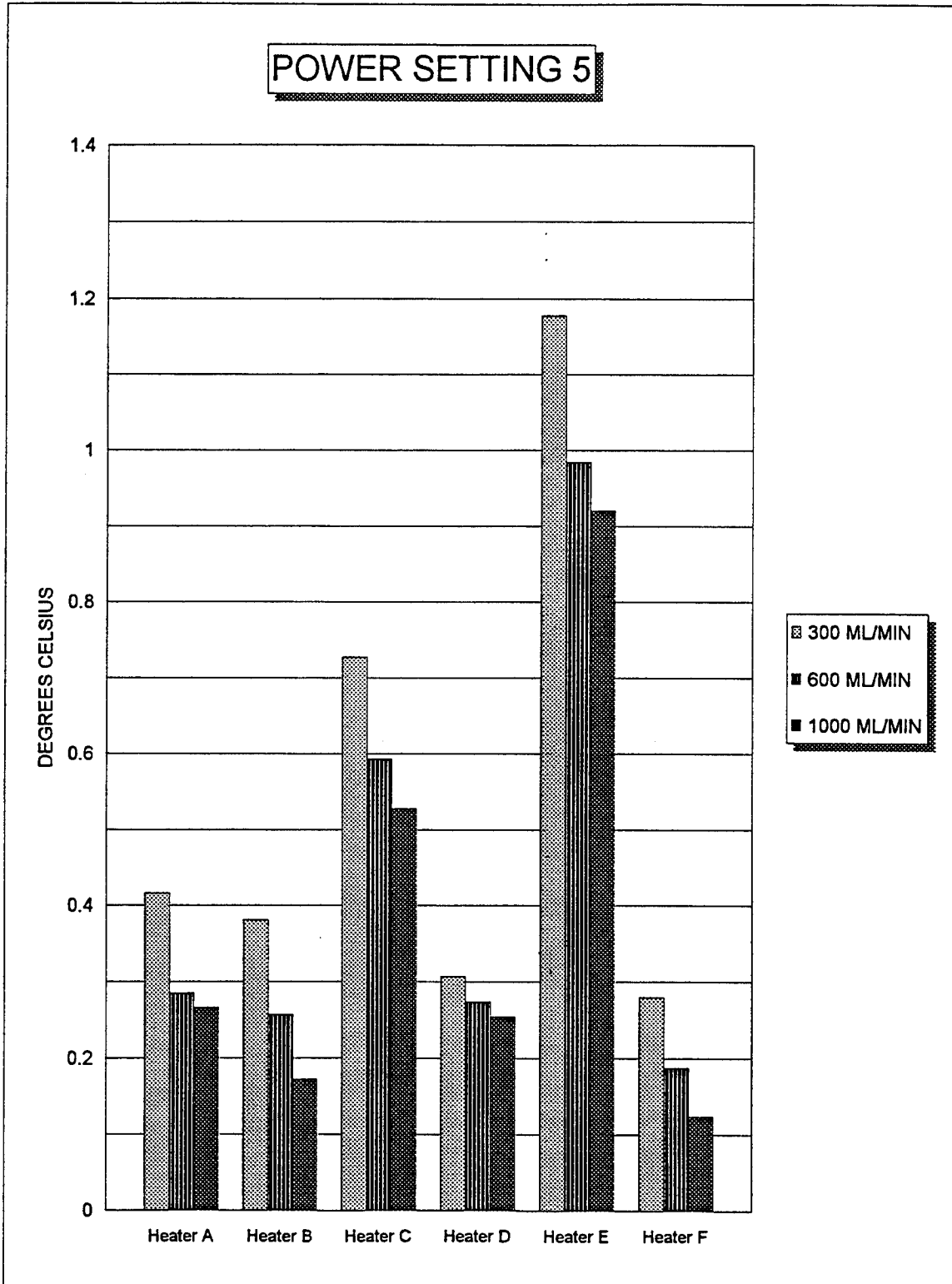

Figure 25. Temp rise across heaters at power setting 5.

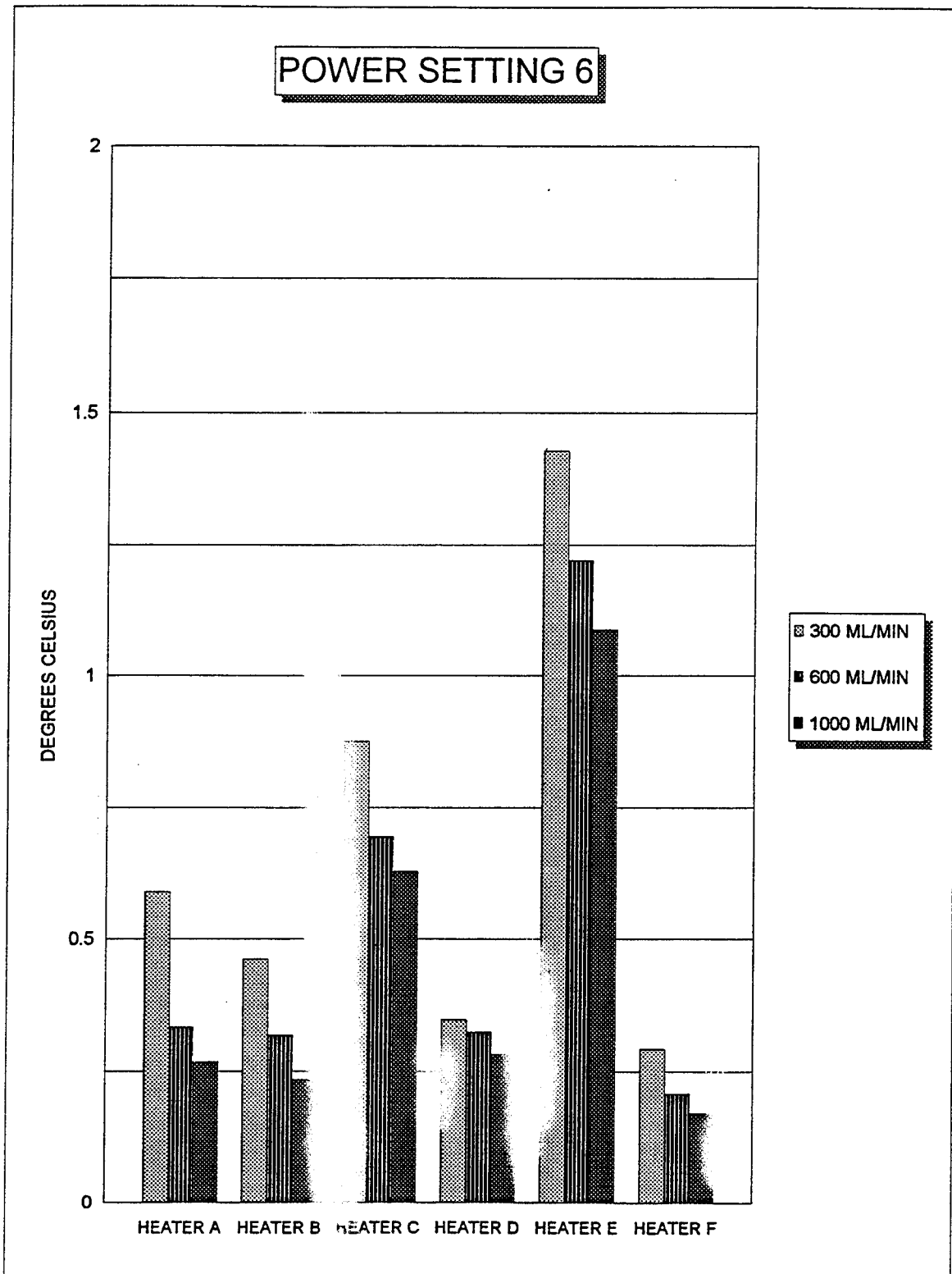

Figure 26. Temp rise across heaters at power setting 6.

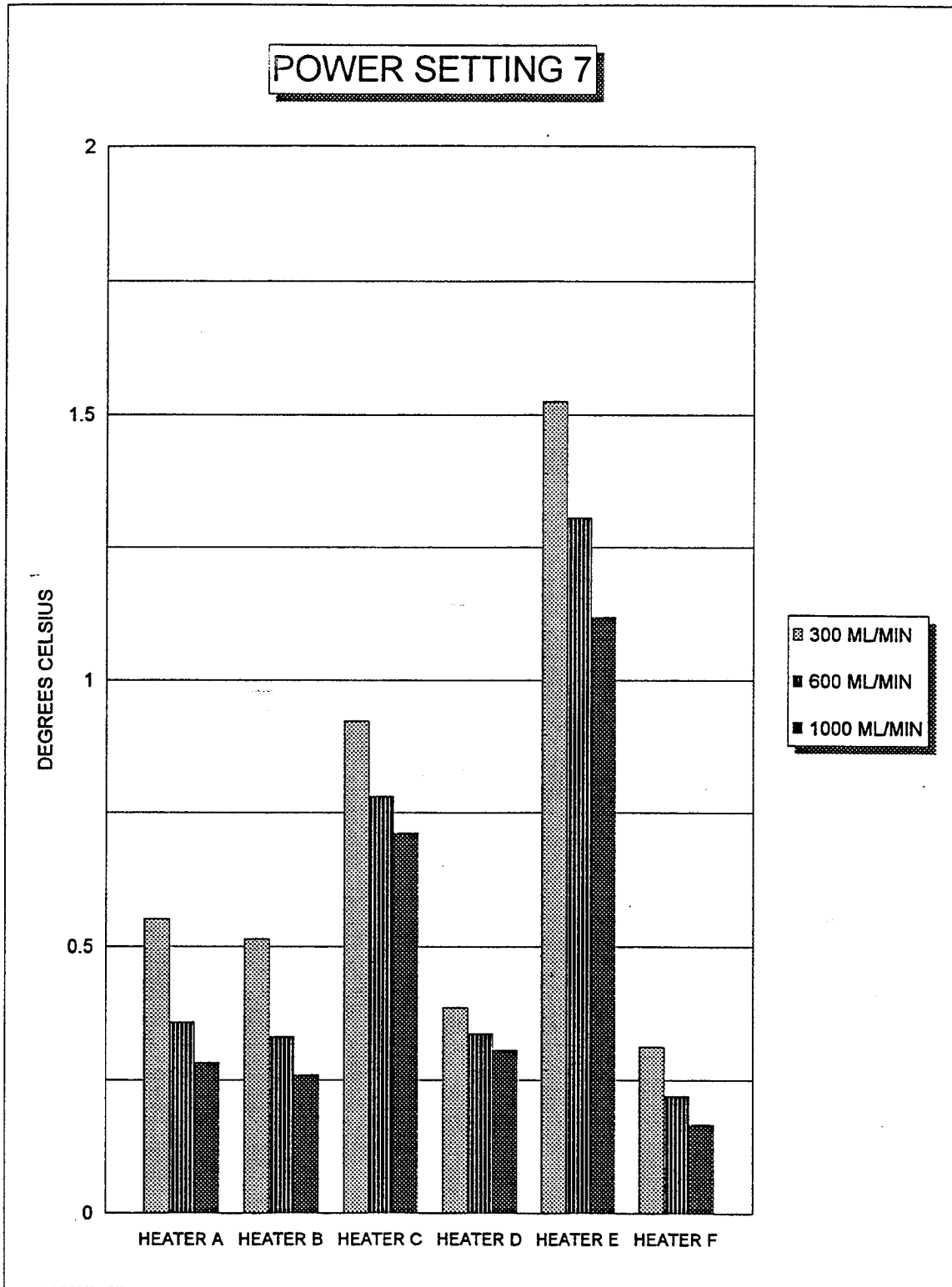

Figure 27. Temp rise across heaters at power setting 7.

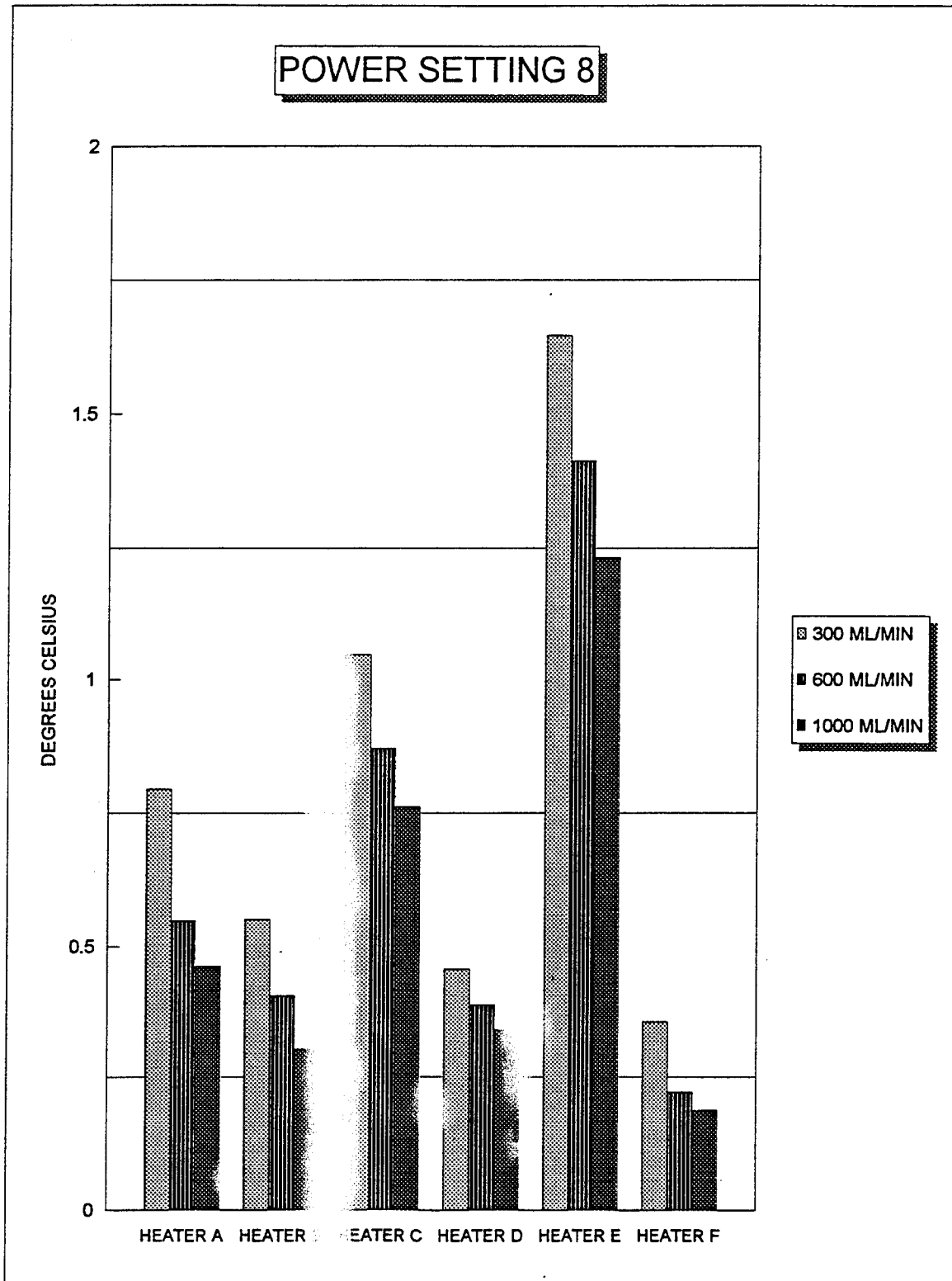

Figure 28. Temp rise across heaters at power setting 8.

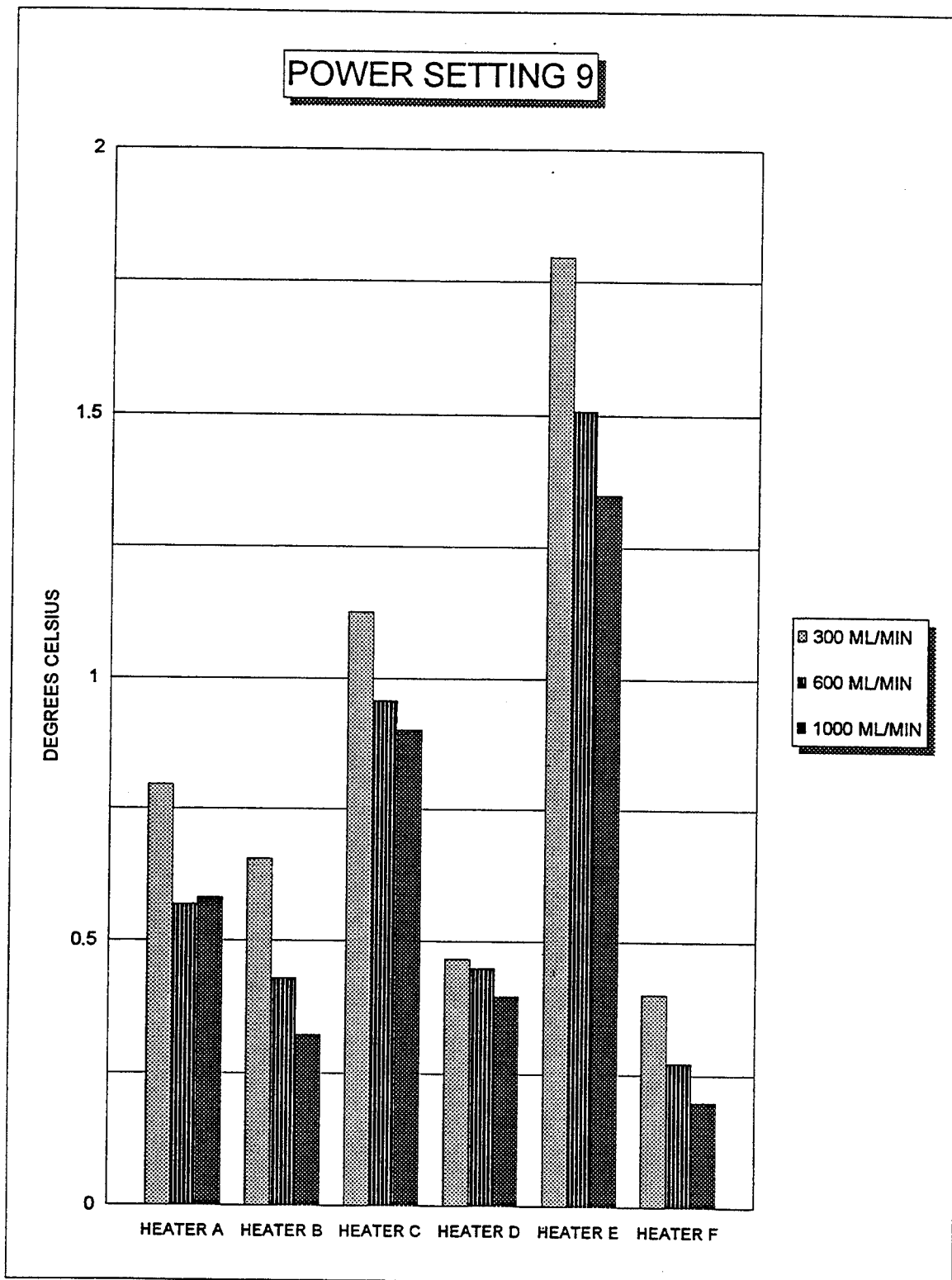

Figure 29. Temp rise across heaters at power setting 9.

POWER SETTING 10

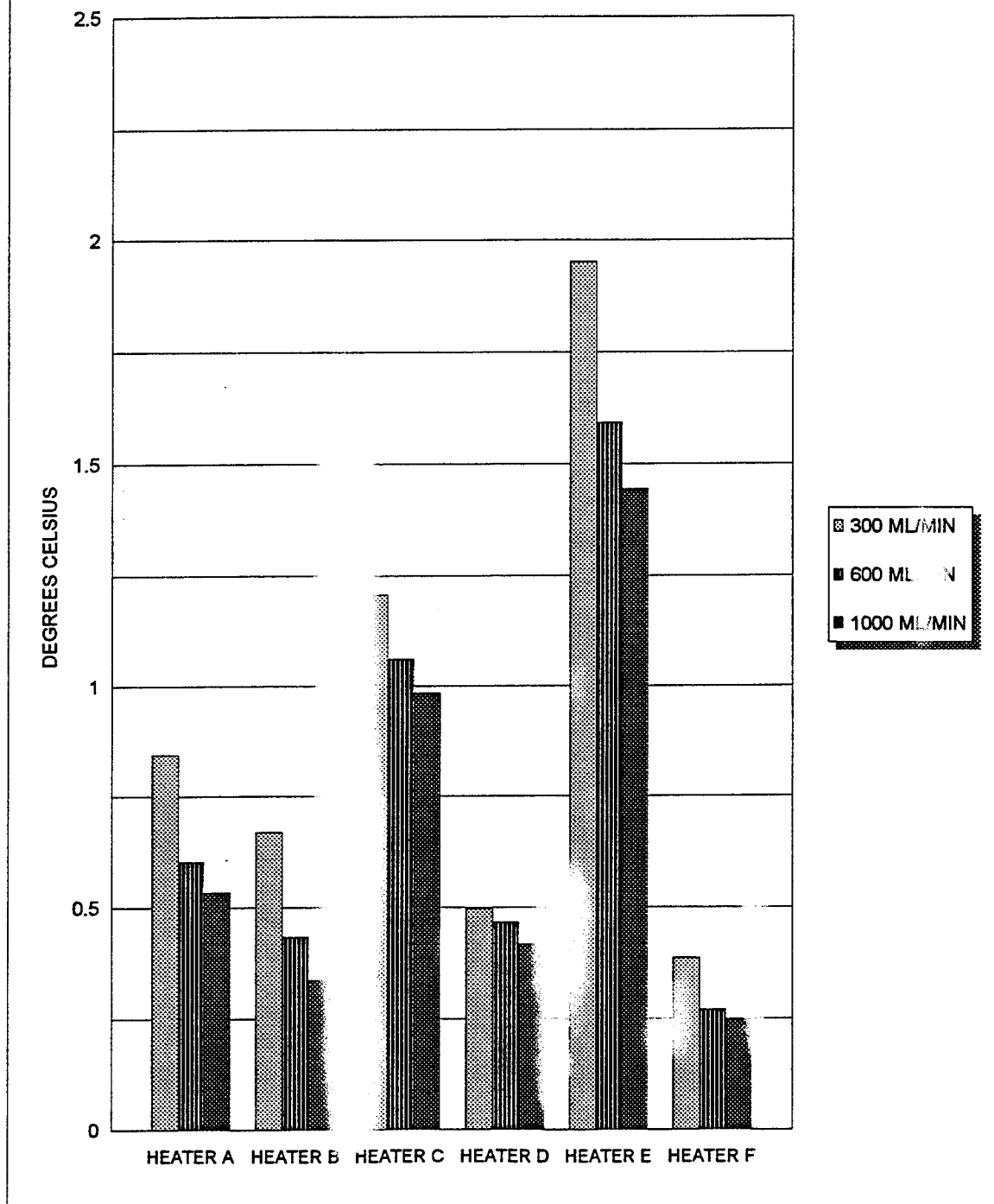

Figure 30. Temp rise across heaters at power setting 10.

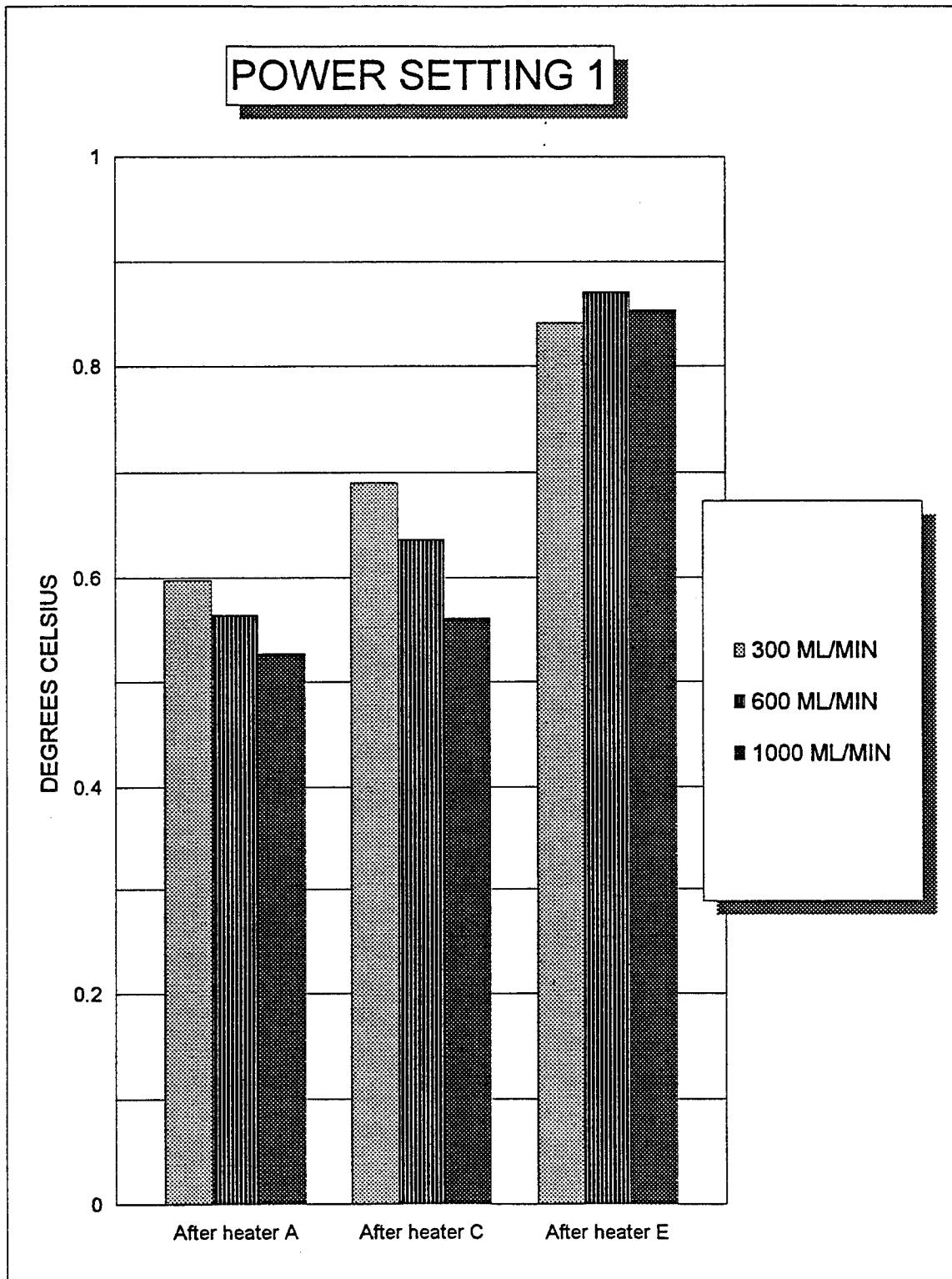

Figure 31. Mid-channel temp drops at power setting 1.

# POWER SETTING 2

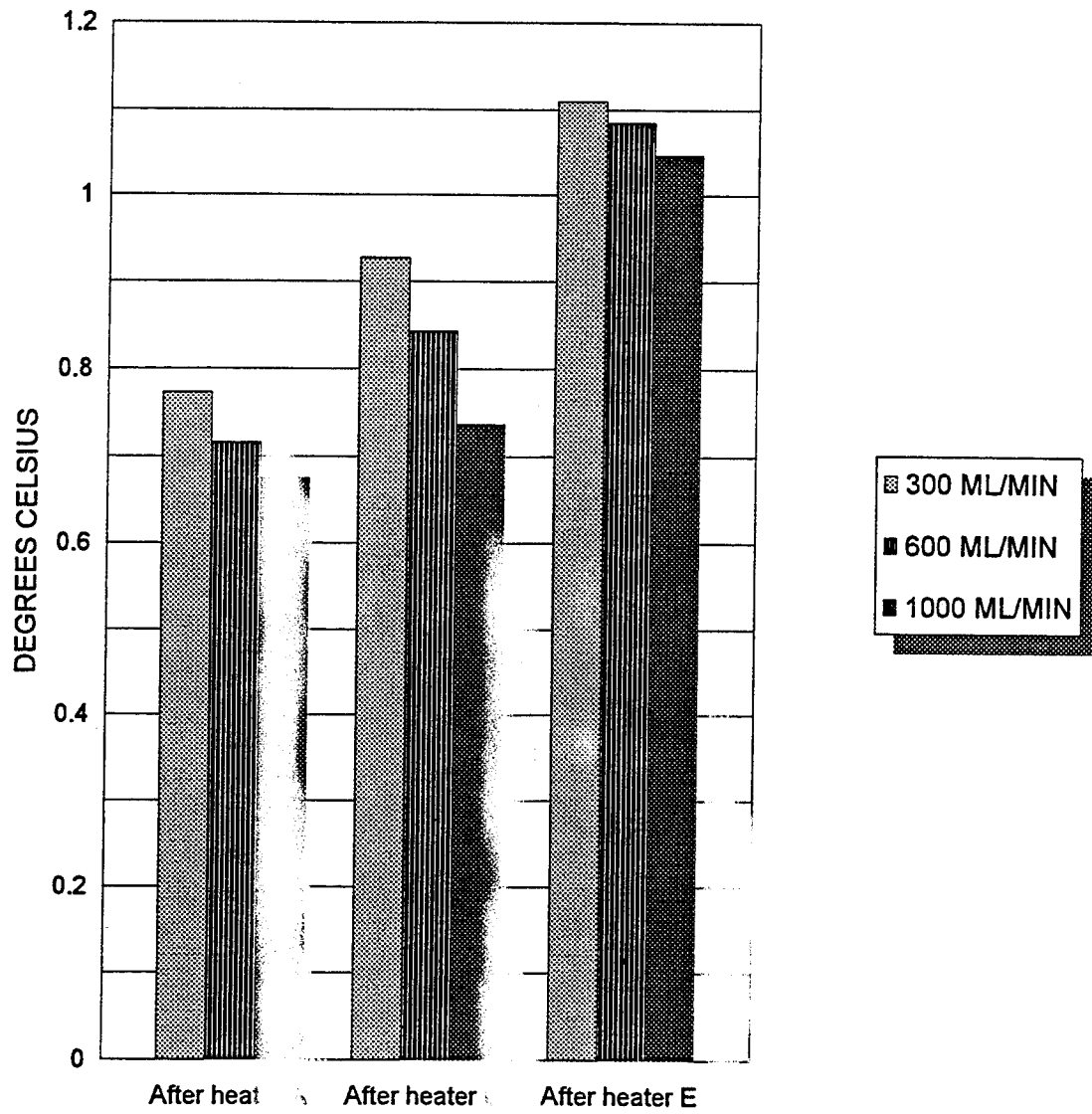

Figure 32. Mid-channel temp drops at power setting 2.

# POWER SETTING 3

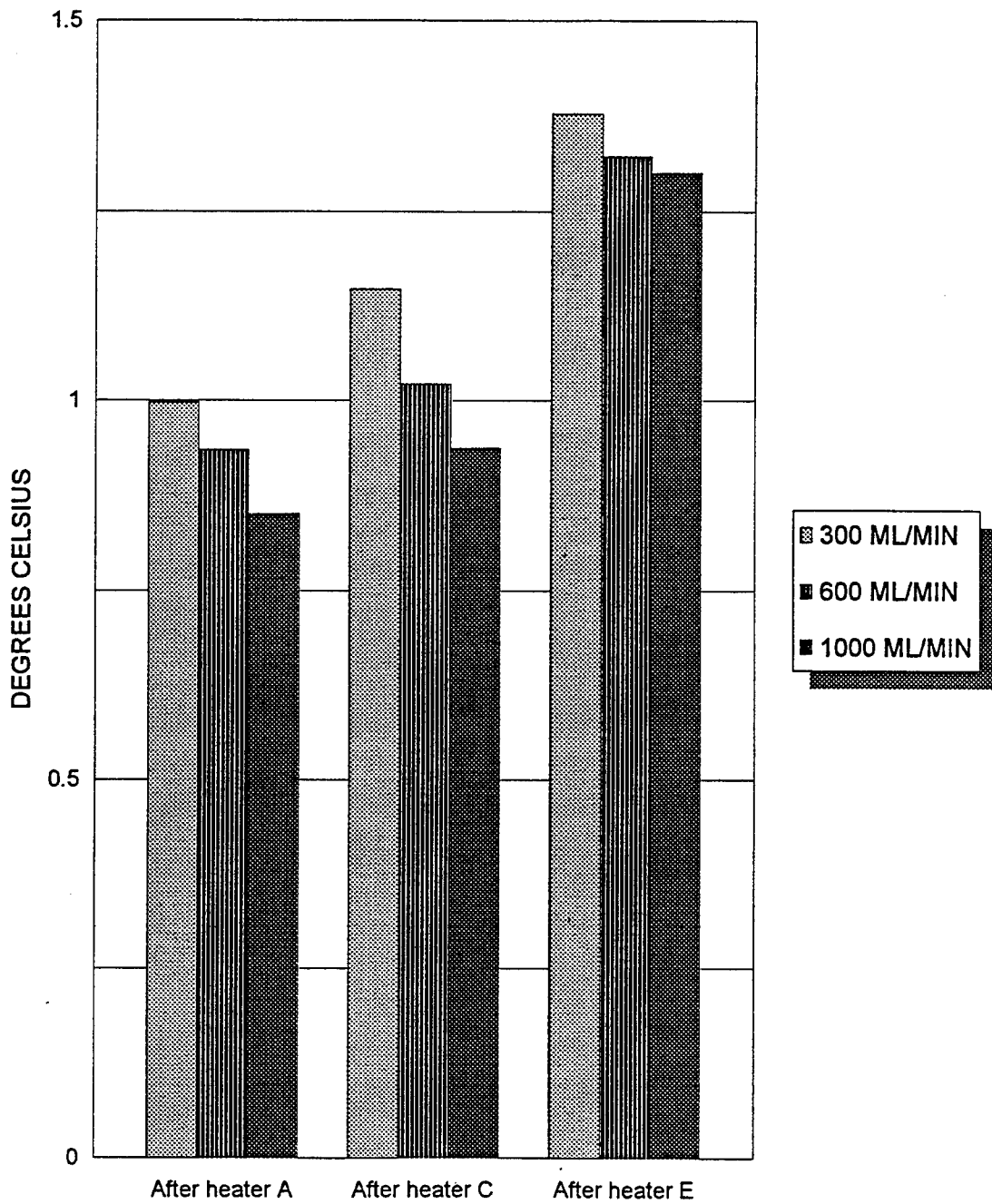

Figure 33. Mid-channel temp drops at power setting 3.

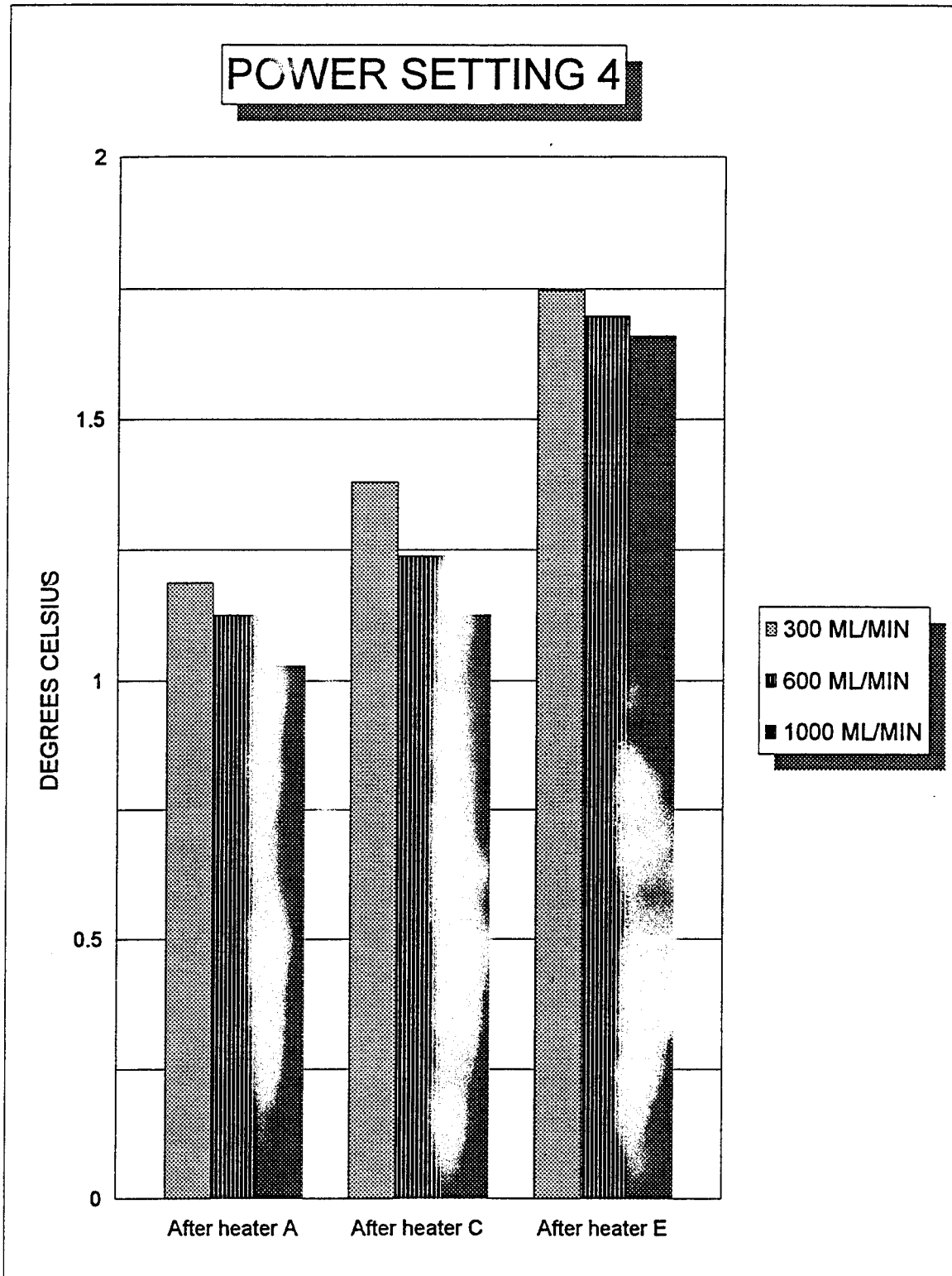

Figure 34. Mid-channel temp drops at power setting 4.

# POWER SETTING 5

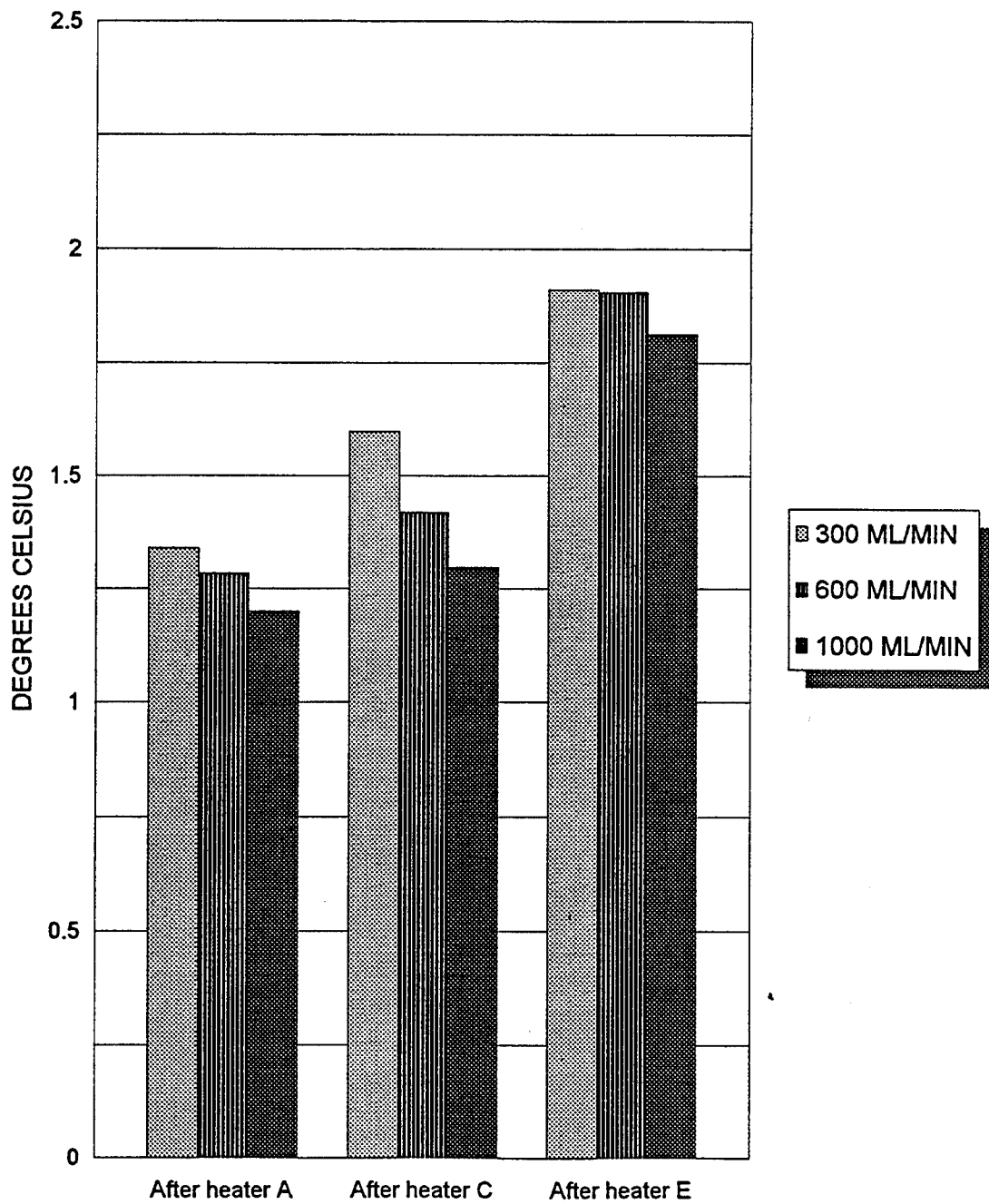

Figure 35. Mid-channel temp drops at power setting 5.

# POWER SETTING 6

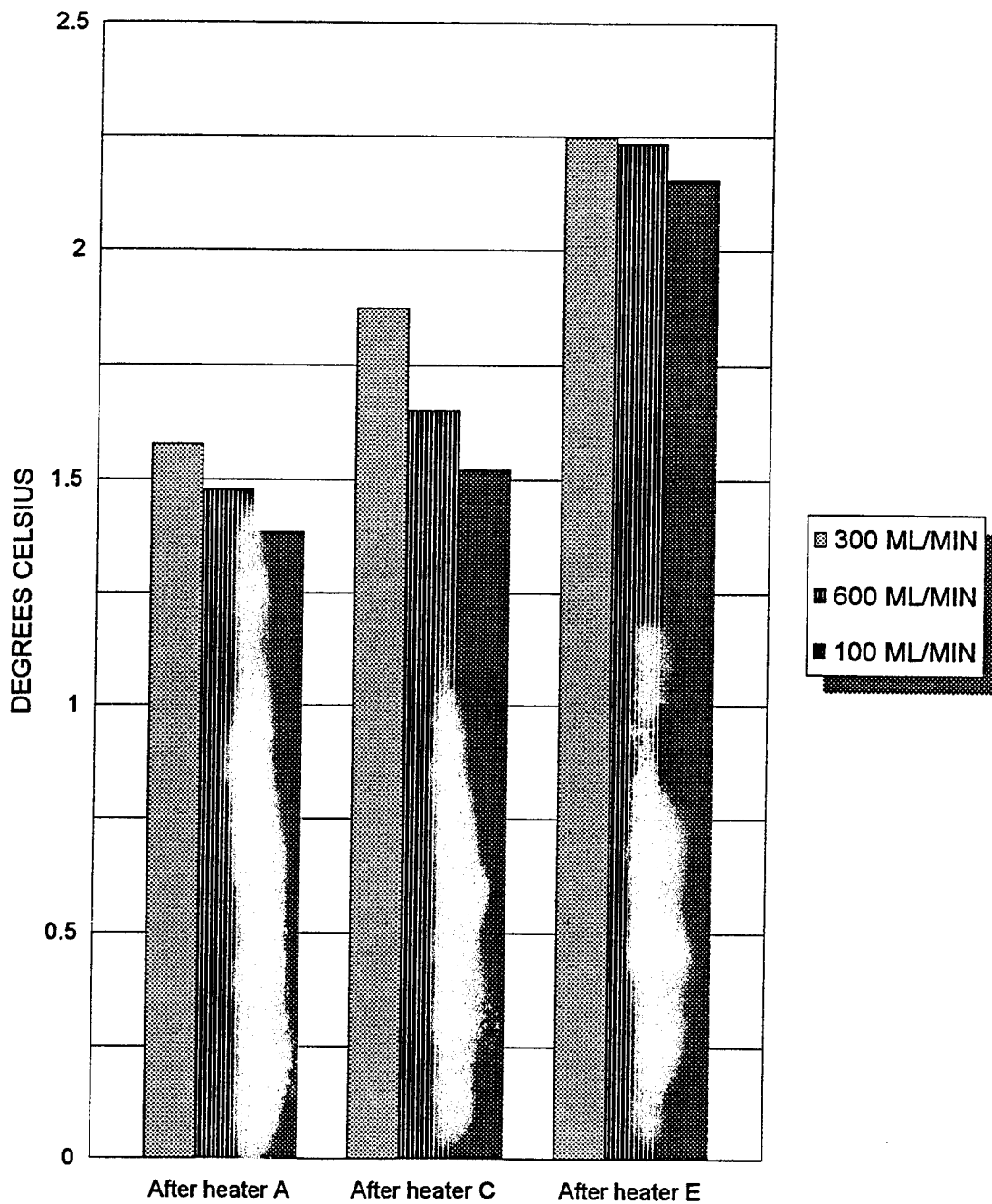

Figure 36. Mid-channel temp drops at power setting 6.

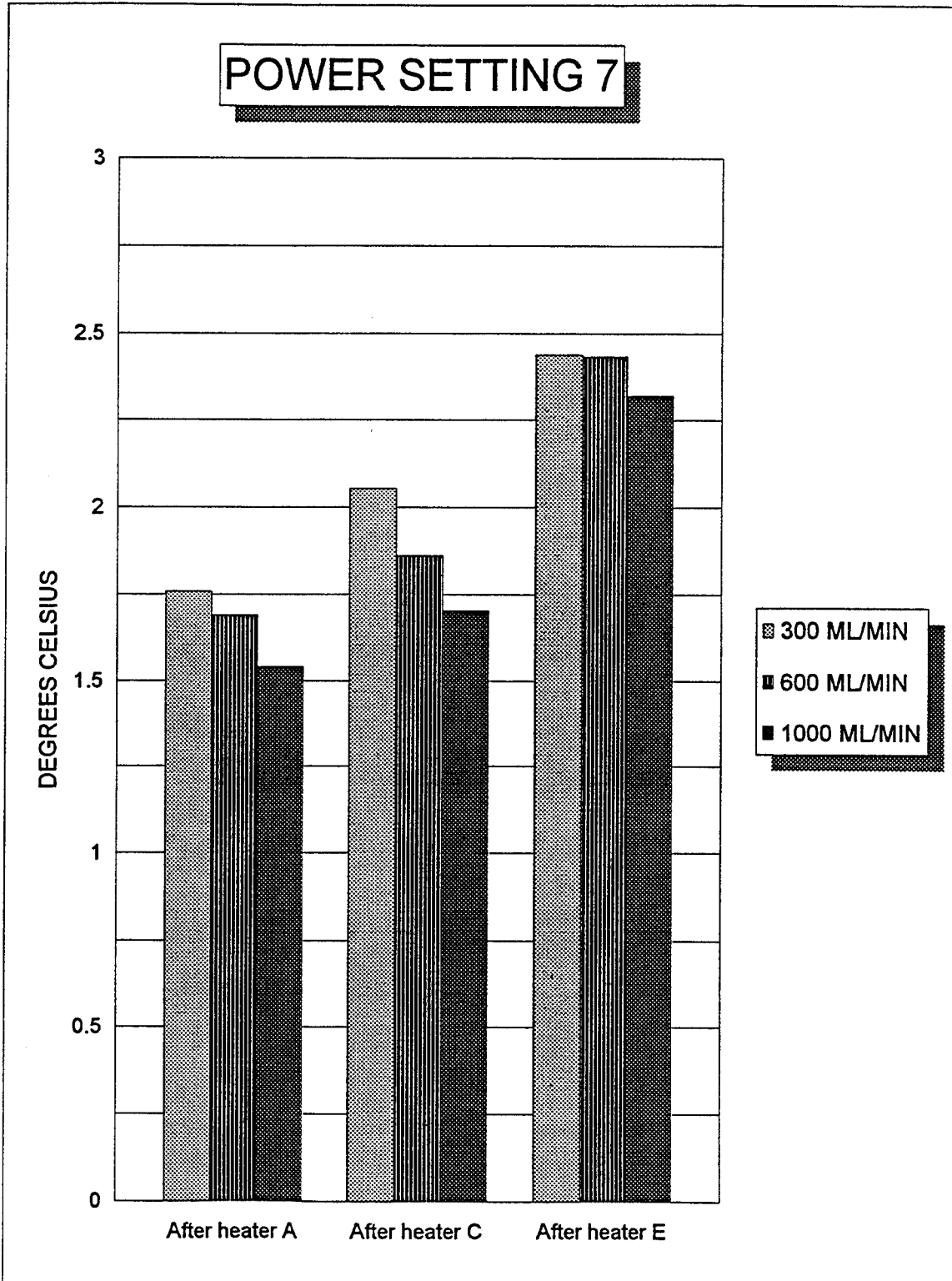

Figure 37. Mid-channel temp drops at power setting 7.

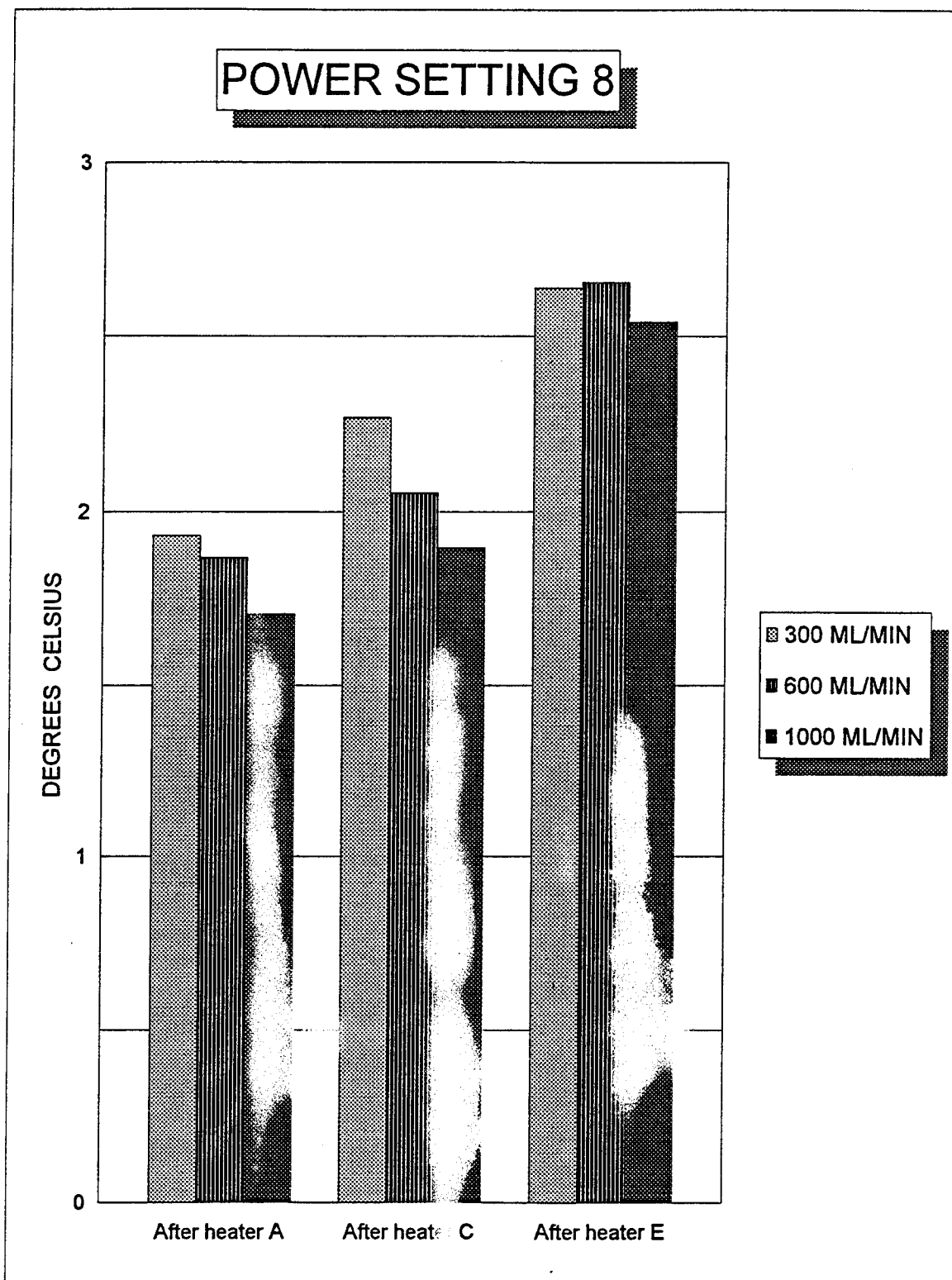

Figure 38. Mid-channel temp drops at power setting 8.

# POWER SETTING 9

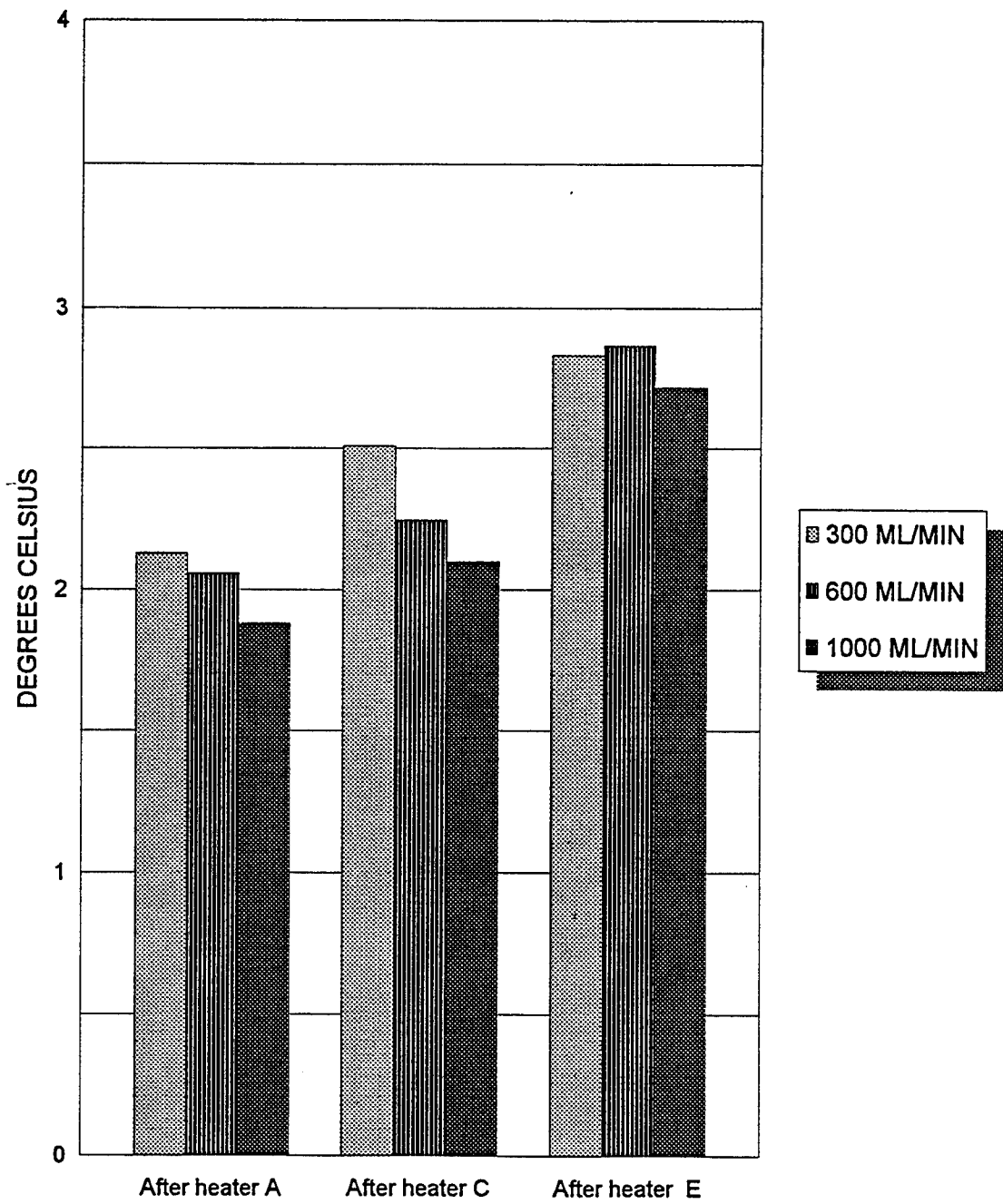

Figure 39. Mid-channel temp drops at power setting 9.

# POWER SETTING 10

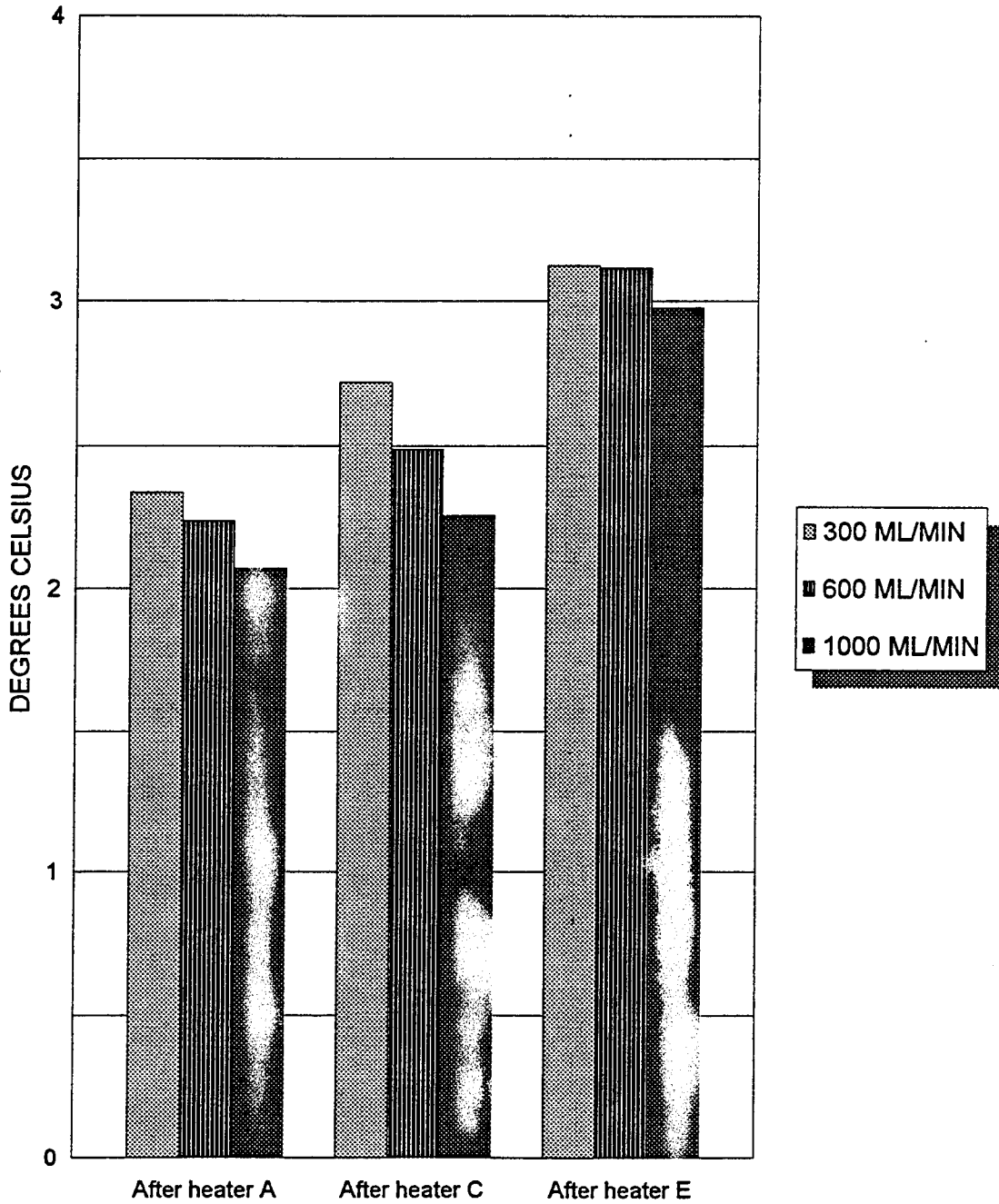

Figure 40. Mid-channel temp drops at power setting 10.

## V. DISCUSSION AND CONCLUSIONS

### A. TEMPERATURE PATTERNS

The data presented in Tables 4 through 13 as well as the graph in Figure 17 most clearly portray the cooling capabilities of the module. As might be expected after viewing Figure 3 (illustrating the coolant flow path) and Figure 6 (showing thermocouple locations), temperatures tend to rise across each heater and drop in the flow channel between heaters. Figures 21 through 40 show these tendencies. The temperatures on the FTM surface basically exhibit an increasing nature along the flow path, with the exception of data from the three thermocouples located between heaters (T(7), T(12), and T(17)).

It also appears that as the coolant enters the module, it has a cooling effect on the flow immediately to its right as viewed in Figure 6. The exact nature of the passage as the fluid turns from one channel to the next is unclear, but one would suspect behavior in this area to be similar to that of a counterflow heat exchanger due to the opposing directions of the flow inside the module and in the entrance channel. The results show a pattern of relatively smaller temperature increases across heater D as measured by thermocouples 13 and 14, as well as a slight decrease at thermocouple 15, where the flow makes the turn into the final flow path through the FTM. Although the flow makes a similar turn in proceeding from thermocouple 9 to thermocouple 10, the temperature continues to increase in that area at the lower flow rates.

The lowest temperature measured on the module surface invariably occurred at thermocouple 7, located between heaters in the first flow pass. The highest surface temperature varied, but was consistently at either thermocouple 16 or 19, located above the final pass after heaters E and F respectively. The temperature midway in this flow pass, as

measured by thermocouple 17, indicated a sharp decrease and thus provides a strong testimony to the effectiveness of the internally occurring convection, at least in this particular area.

While efforts were made to ensure consistency and accuracy, the narrow range of temperatures being measured created difficulties. Slight flutter in the flow rate combined with temperature variations exiting the reservoir in the refrigerated bath caused noticeable fluctuations in the coolant inlet temperature and thus the surface temperature data. Such fluctuations, which approached  $0.2^{\circ}\text{C}$  at the higher flow and the higher power settings, indicated that the bath was experiencing difficulty in uniformly cooling the flow prior to its return to the module. This provided the motivation for averaging sixty of the inlet and outlet temperatures over approximately 25 seconds. Still, it must be recognized that these two temperatures would have to be precisely spaced in order to ensure that the measurements reflected both the inlet and outlet temperatures of the same "slug" of fluid. Because of their relatively simultaneous measurement, there is an inherent inaccuracy in the resulting temperature differential.

It was noted during the experiments that a slight increase (or decrease) in inlet temperature for runs at the same power level and flow rate would result in relatively the same magnitude increase (or decrease) in module surface temperatures, although the temperature differential experienced between the inlet and outlet was relatively stable. For example, decreasing inlet temperature  $0.5^{\circ}\text{C}$  would result in a similar drop in surface and exit temperatures, but the temperature rise from inlet to outlet would not significantly change. With this knowledge, efforts were made to be relatively consistent regarding inlet temperatures. It was observed that if the flow were entering at a temperature

higher than room temperature, insulation layer temperatures might not steadily decrease from the inner layer (thermocouple 2) to the outer layer (thermocouple 0), indicating the likelihood of heating from the ambient air. Such heating could only be assumed to skew all data. In general, inlet temperatures were sought in the vicinity of room temperature as determined by readings prior to energizing the refrigerated bath or power supply.

In some instances, the data may show surface temperatures to have actually decreased when in fact power was held constant and flow was decreased, creating a situation where the opposite would be expected. The absence of a temperature rise on the module surface may be best explained by noting the inlet temperature (thermocouple 3) and the temperature of thermocouple 0, which was near ambient. If an odd decrease in surface temperatures occurs in the data, these two thermocouples tend to indicate that either entrance temperature or room temperature had increased (or both).

During the course of experimental runs, the room temperature undoubtedly changed. Bath temperature was frequently adjusted as well since at higher flow rates the ability of the bath to cool fluid prior to its re-entering the flow was challenged.

## **B. HEAT TRANSFER CALCULATIONS**

Though the temperature differential between fluid inlet and outlet steadily increased with decreasing flow rate as expected (Figure 17), the energy absorbed by the coolant ( $Q_f$ ) did not always decrease with decreasing flow (Figure 19). Even more unusual was the tendency to have the calculated  $Q_f$  exceed the total power to the heaters. This occurred in 60 of the 80 runs (75%), with calculations yielding up to a 13.8% increase. Similar baffling results were produced in experiments conducted by the Crane Division of the Naval

Surface Warfare Center, where 16 of 23 (69.6%) flow and power settings resulted in thermal efficiencies in excess of 100%, with values as high as 110.9% calculated (Buechler and Brough, 1993), though no conclusion was reached as to why this was occurring.

Several possible avenues for resolving these results were explored. Because each calculation of heat absorbed by the fluid depended upon only three experimentally measured quantities (flow and inlet and outlet temperature), calibration of the flowmeter and thermocouples 3 and 4 was repeated to verify previous results. While the thermocouple recalibration using the Rosemount 920A commutating bridge and a constant temperature ethylene glycol bath narrowed the uncertainty, the flowmeter calibration fell within the original uncertainty. Uncertainty calculations (see Appendix B) took into account flowmeter calibration and temperature uncertainty, however the values obtained were not sufficient to account for the discrepancy in all cases.

Data was collected over a two hour period beginning when steady state appeared to have been reached for the same power and flow settings to determine if inadequate time was being allowed between runs. No noticeable changes in temperature data were encountered.

Thermocouple placement in the inlet and exit flow was also adjusted with no change in results. The thermocouples were, however, approximately 11.5 cm from the actual inlet and exit of the module due to limitations in the assembly of tubing and connections. This could very possibly account for a small temperature difference that could bring the data into a feasible range. Because of the relatively small power levels, slight temperature differences had significant impacts on results.

Coolant properties (density and specific heat) used in calculations were based on linear interpolations between

values supplied by the manufacturer. A hydrometer was used to measure coolant density at 20°C as 0.7975 g/ml, while the manufacturer's data specified a density of 0.794 g/ml. While possibly a very significant discovery, this would only tend to drive the measured heat dissipation levels further beyond 100% thermal efficiency.

Having pursued several possible solutions to no avail, the specific heat of the fluid was investigated to determine whether it matched manufacturer's data. Testing performed by an independent laboratory using a differential scanning calorimeter gave a possible indication that specific heat data used for the experiments was erroneous. Two tests at 93°C resulted in  $C_p$  values of 0.57 cal/(g°C), slightly less than manufacturer's data shown in Table 3. Two tests conducted at 66°C (150°F) indicated  $C_p$  values of 0.54 cal/(g°C), while a linear interpolation using Table 3 produces 0.56 cal/(g°C). Assuming that the specific heat is indeed linear in this region, as Table 3 seems to indicate, an extrapolation of the test data and utilization of the obtained figures in determining specific heat would lower calculated specific heat values by approximately seven percent in the range of testing. As a result, energy balance calculations for the coolant would also be reduced by the same factor. Thus, the 76.17 W value obtained for power setting 10 (69.68 W) at 1000 ml/min would become 70.88 W, well within the 5.7 W uncertainty calculated in Appendix B. Figure 20 shows a sampling of power settings and the impact of the differences in specific heat values.

The possibility of contamination of the coolant was explored, although all fluid circulation components were flushed with the coolant prior to experiments. It was noticed late in the data collection process that the tubing in the pump head had split. An examination of the tubing and comparison with new tubing revealed a hardening had occurred during the course of usage, indicating the likelihood of some

sort of reaction between the Tygon tubing and the polyalphaolefin. A conversation with the coolant manufacturer supported this as a possible source of contamination. The progressive nature of such contamination would expectedly cause data from early experiments to differ from data collected later at the same settings, however this was not the case.

Due to the variations in heater resistances, power into each heater was not identical. It was noted that the power into heaters D and F was usually lower than that of the other heaters by approximately 0.1 W. This might account for some minor diminishing of the temperature rise which would have occurred if all heater powers were uniform. Wire resistances between multiplexers and lead wires were measured for both heaters and precision resistors and found to be 0.1 ohms or less in all cases. Hewlett-Packard manuals indicated that the voltage measurements of the HP 44701A voltmeter such as was utilized vary only by  $\pm(0.008\% + 700E-6)$  volts (Hewlett-Packard, 1987). Uncertainty for the power to each heater was thus very small (see Appendix B calculations).

Given the results and conclusions drawn from the subsequent analysis, it is suspected that the measured temperature differential (outlet minus inlet temperature) was not sufficiently accurate due to the slight fluctuations in inlet temperature, particularly at higher flow rates. At lower flow rates, the pump produced a more "pulsed" flow that may have resulted in degraded accuracy in the inlet and outlet temperature measurements.

## VI. RECOMMENDATIONS

In order to minimize uncertainty in further research with the FTM, three recommendations are made. First, use of a larger volume refrigerated bath might aid in stabilizing inlet temperatures by allowing greater resident time for coolant prior to its entrance to the module. Additionally, efforts should be made to place thermocouples in the inlet and outlet tubing closer to the actual module inlet and outlet. The combination of these two changes would lend greater credibility to the resulting energy balance by reducing the uncertainty in the fluid temperature differential. Finally, efforts should be made to determine the uncertainty of the coolant's thermophysical properties prior to further experimentation.

A closer examination of the surface temperatures in the vicinity of the inlet channel (as shown in Figure 6) through the emplacement of additional thermocouples would be useful in the study of the counterflow heat exchanger effect in that region. Thermocouple placement along the right side of the module in the areas where flow changes direction and exits the FTM would aid in the analysis of the heat transfer mechanisms in operation there. Analytical modelling of the FTM could be enhanced by data obtained through these changes.

An x-ray of the module would provide valuable information regarding the internal structure. Of particular interest would be the structure in the areas where flow direction changes and in the inlet and exit channels.

Finally, the use of thermochromic liquid crystals would provide a complete visual image of the surface temperature patterns at various power and flow settings. Pictures of these images could be compared with the temperature data for verification.



## APPENDIX A. SAMPLE CALCULATIONS

Throughout this appendix, the sample calculations are based upon power setting 10 at a flow rate of 1000 ml/min. Data used for calculations is shown in Tables 17 and 27.

### 1. Calculation of Coolant Thermophysical Properties

From Equation 4,

$$T_{\text{avg}} = \frac{(T(4) + T(3))}{2} = 19.37^{\circ}\text{C}$$

Density was calculated using Equation 5 as follows:

$$\rho = 0.794 - (8.5\text{E-}4) * (19.37 - 20) = 0.7945 \text{ g/ml}$$

Specific heat was determined via Equation 6 as:

$$C_p = (0.52 + (7.1\text{E-}4 * (19.37 - 10)) * 4.184 = 2.204 \text{ J/(g}^{\circ}\text{C)}$$

### 2. Calculation of Heat Dissipation

Table 24 shows the data used in Equation 7 to determine  $\Delta T_{\text{avg}} = 2.61$  as obtained by calculation within the data collection. Utilizing this value, heat absorbed by the fluid was calculable as:

$$Q_f = \frac{(0.7945) * (1000) * (2.204) * (2.61)}{60} = 76.17 \text{ W}$$

Insulation losses were determined using Equation 9 as:

$$Q_{\text{ins}} = \frac{(0.04) * (0.0219)}{0.0191} (19.62 - 18.20) = 0.07 \text{ W}$$

Dividing the above result by area results in:

$$q''_{\text{ins}} = \frac{(0.04)}{0.0191} (19.62 - 18.20) = 2.97 \text{ W/m}^2$$

DEGREES CELSIUS				DEGREES CELSIUS			
SAMPLE #	T(3) INLET	T(4) OUTLET	T(4) - T(3)	SAMPLE #	T(3) INLET	T(4) OUTLET	T(4) - T(3)
1	18.184	20.778	2.595	31	18.045	20.677	2.632
2	18.162	20.746	2.584	32	18.040	20.672	2.632
3	18.147	20.770	2.622	33	18.056	20.655	2.600
4	18.145	20.756	2.611	34	18.034	20.659	2.625
5	18.165	20.756	2.591	35	18.036	20.638	2.602
6	18.151	20.734	2.583	36	18.024	20.645	2.620
7	18.138	20.737	2.600	37	18.031	20.652	2.621
8	18.151	20.732	2.581	38	18.034	20.627	2.593
9	18.135	20.746	2.611	39	18.010	20.641	2.631
10	18.111	20.747	2.636	40	18.025	20.660	2.635
11	18.146	20.719	2.572	41	18.018	20.632	2.614
12	18.126	20.742	2.616	42	18.025	20.634	2.608
13	18.130	20.719	2.589	43	18.029	20.627	2.598
14	18.135	20.731	2.597	44	18.002	20.622	2.620
15	18.125	20.725	2.600	45	17.976	20.629	2.653
16	18.096	20.726	2.630	46	18.008	20.609	2.602
17	18.119	20.723	2.604	47	18.009	20.608	2.600
18	18.102	20.718	2.616	48	17.998	20.606	2.608
19	18.111	20.701	2.590	49	18.009	20.613	2.604
20	18.117	20.711	2.594	50	17.968	20.584	2.616
21	18.102	20.689	2.588	51	17.979	20.611	2.632
22	18.102	20.704	2.603	52	17.957	20.595	2.638
23	18.103	20.688	2.585	53	17.976	20.591	2.615
24	18.076	20.696	2.620	54	17.973	20.604	2.631
25	18.081	20.680	2.599	55	17.980	20.585	2.604
26	18.080	20.679	2.599	56	17.985	20.589	2.604
27	18.051	20.674	2.623	57	17.981	20.580	2.599
28	18.061	20.678	2.617	58	17.972	20.581	2.609
29	18.044	20.672	2.628	59	17.979	20.581	2.603
30	18.060	20.678	2.618	60	17.970	20.590	2.620
<b>COLUMN SUM</b>	543.456	621.555	78.102	<b>COLUMN SUM</b>	540.129	618.597	78.469
<b>AVERAGE TEMPERATURE DIFFERENTIAL = (78.469 + 78.102)/60 = 2.61</b>							

Table 24. Calculation of  $\Delta T_{avg}$ .

## APPENDIX B. UNCERTAINTY CALCULATIONS

Uncertainty calculations were evaluated using the root mean square method (Beckwith, Marangoni, and Lienhard, 1993). Table 24 provides a summary of the uncertainty in variables used for calculations.

VARIABLE	UNITS	UNCERTAINTY	REFERENCE
v	ml/min	maximum of 2.8% in range of testing	Flowmeter calibration (see Table 26 and corresponding curve fit in Figure 41)
T	°C	0.13°C	Thermocouple calibration (see Table 27)
V	volts	0.008% + 700E-6	Integrating voltmeter manual (Hewlett- Packard, 1987)
R	ohms	0.0001 ohms	Precision resistor calibration
A	square meters	10% (0.00219 square meters)	Estimated
L	meters	0.003 m	Ruler resolution

**Table 25.** Uncertainties in variables.

Uncertainty in  $\Delta T_{avg} = (T_{out}(avg) - T_{in}(avg))$  was calculated as:

$$U_{\Delta T_{avg}} = \sqrt{(U_T)^2 + (U_T)^2} \quad (10)$$

Thus, for the stated uncertainty in T,

$$U_{\Delta T_{avg}} = \sqrt{(0.13)^2 + (0.13)^2} = 0.18^\circ\text{C} \quad (11)$$

For power setting 10 (69.68 W input) and a flow setting of 1000 ml/min

$$\begin{aligned} \rho &= 0.7945 \text{ g/ml}, & C_p &= 2.203 \text{ J/(g}^\circ\text{C)}, \\ \Delta T_{\text{avg}} &= 2.61^\circ\text{C}, & \Delta T_{\text{ins}} &= 0.40^\circ\text{C}, \\ k &= 0.04 \text{ W/(m}^\circ\text{C)}, & L &= 0.0191 \text{ m, and} \\ A &= 0.0219 \text{ m}^2. \end{aligned}$$

The uncertainty in  $Q_f$  was calculated as:

$$\begin{aligned} Q_f &= \frac{\rho C_p}{60} \sqrt{((v) (\Delta T_{\text{avg}}))^2 + ((\Delta T_{\text{avg}}) (V))^2} \\ Q_f &= 5.7 \text{ W} \end{aligned} \quad (12)$$

Uncertainty in the insulation losses is calculated as:

$$\begin{aligned} U_{Q_{\text{ins}}} &= \sqrt{\left( (U_{\Delta T}) \left( \frac{\delta Q_{\text{ins}}}{\delta \Delta T_{\text{ins}}} \right) \right)^2 + \left( (U_L) \left( \frac{\delta Q_{\text{ins}}}{\delta L} \right) \right)^2 + \left( (U_A) \left( \frac{\delta Q_{\text{ins}}}{\delta A} \right) \right)^2} \approx 0.01 \text{ W} \\ \text{where } \left( \frac{\delta Q_{\text{ins}}}{\delta \Delta T_{\text{ins}}} \right) &= \frac{kA}{L} \\ \left( \frac{\delta Q_{\text{ins}}}{\delta L} \right) &= \frac{kA\Delta T_{\text{ins}}}{L^2} \\ \text{and } \left( \frac{\delta Q_{\text{ins}}}{\delta A} \right) &= \frac{k\Delta T_{\text{ins}}}{L} \end{aligned} \quad (13)$$

Similarly  $U_{q''_{\text{ins}}}$  is determined as follows:

$$\begin{aligned} U_{q''_{\text{ins}}} &= \sqrt{\left( (U_L) \left( \frac{\delta q''_{\text{ins}}}{\delta L} \right) \right)^2 + \left( (U_{\Delta T}) \left( \frac{\delta q''_{\text{ins}}}{\delta \Delta T_{\text{ins}}} \right) \right)^2} \approx 0.38 \text{ W/m} \\ \text{where } \left( \frac{\delta q''_{\text{ins}}}{\delta L} \right) &= \frac{-k\Delta T_{\text{ins}}}{L^2} \\ \text{and } \left( \frac{\delta q''_{\text{ins}}}{\delta \Delta T_{\text{ins}}} \right) &= \frac{k}{L} \end{aligned} \quad (14)$$

Uncertainty in the power calculations was determined as:

$$U_{P_h} = \sqrt{\left( (U_{V_h}) \left( \frac{\delta P_h}{\delta V_h} \right) \right)^2 + \left( (U_{V_r}) \left( \frac{\delta P_h}{\delta V_r} \right) \right)^2 + \left( (U_r) \left( \frac{\delta P_h}{\delta R} \right) \right)^2}$$

where  $\left( \frac{\delta P_h}{\delta V_h} \right) = \frac{V_r}{R}$  (15)

$$\left( \frac{\delta P_h}{\delta V_r} \right) = \frac{V_h}{R}$$

and  $\left( \frac{\delta P_h}{\delta R} \right) = \frac{-V_h V_r}{R^2}$

For heater A at power setting 10, with  
 $V_h = 16.27$  volts,  $V_r = 0.35$  volts, and  
 $R = 0.4876$  ohms (determined as discussed in Chapter II),  
calculations yield  $U_{P_h} = 0.07$  W.

Specific heat data from the manufacturer of the polyalphaolefin and testing results performed by an independent laboratory are plotted in Figure 42. Testing data was extrapolated to show values in the temperature range of this research.

%FLOW	MIN/ (2L)	UNCERTAINTY (MIN)	ML/MIN	%UNCERTAINTY
0	0.00	0.00	0	0.0
10	34.27	0.17	58	0.0
15	18.00	0.17	111	0.1
20	12.50	0.17	160	0.2
25	8.00	0.13	250	0.4
30	5.77	0.10	347	0.6
35	4.63	0.10	432	0.9
40	4.02	0.10	498	1.2
45	3.53	0.07	566	1.1
50	3.13	0.07	638	1.4
55	2.87	0.07	698	1.6
60	2.60	0.07	769	2.0
65	2.37	0.07	845	2.4
70	2.17	0.05	923	2.1
75	2.05	0.05	976	2.4
80	1.90	0.05	1053	2.8
85	1.80	0.05	1111	3.1
90	1.68	0.03	1188	2.4
100	1.50	0.03	1333	3.0

**Table 26.** Flowmeter calibration with estimated uncertainty.

PLATINUM RESISTANCE THERMOMETER (°C)	INLET T(3) (°C)	OUTLET T(4) (°C)
17.101	16.983	16.972
17.841	17.742	17.721
19.380	19.271	19.272
25.149	25.091	25.078
30.275	30.197	30.185
30.294	30.216	30.180
36.043	36.044	36.014
41.980	41.936	41.925
46.376	46.354	46.347

**Table 27.** Calibration of inlet and outlet thermocouples.

Calibration of Flow Meter

6 Eqn 183  $y=(atbx+cx^2+dx^3+ex^4+fx^5)$   $r^2=0.999555892$   
 $a=1.5241633$   $b=-1.7630694$   $c=0.80821543$   
 $d=-0.016602833$   $e=0.00015000422$   $f=-4.9736723E-07$

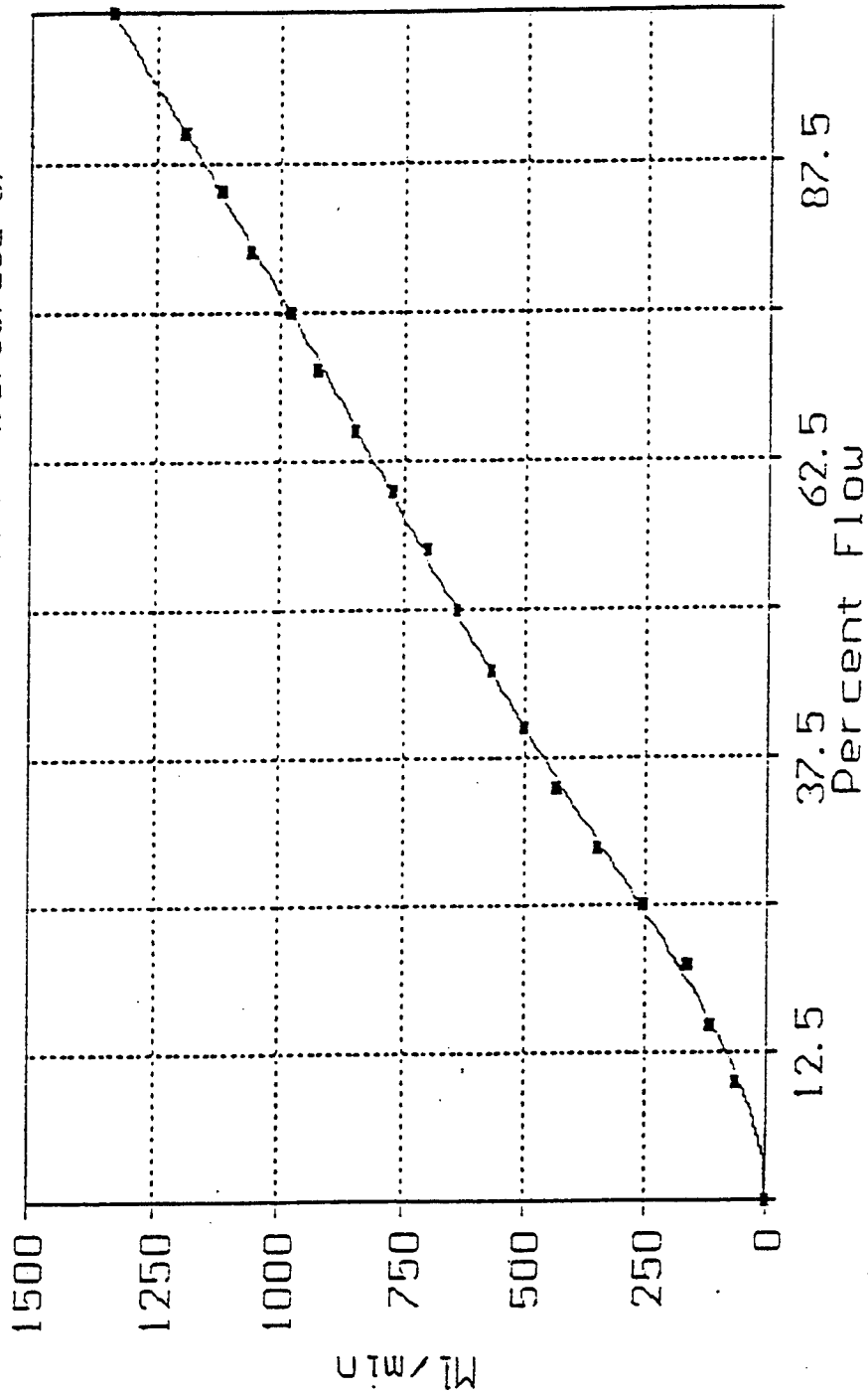

Figure 41. TableCurve polynomial fit of flowmeter calibration data.

### Specific Heat of Brayco Micronic 889

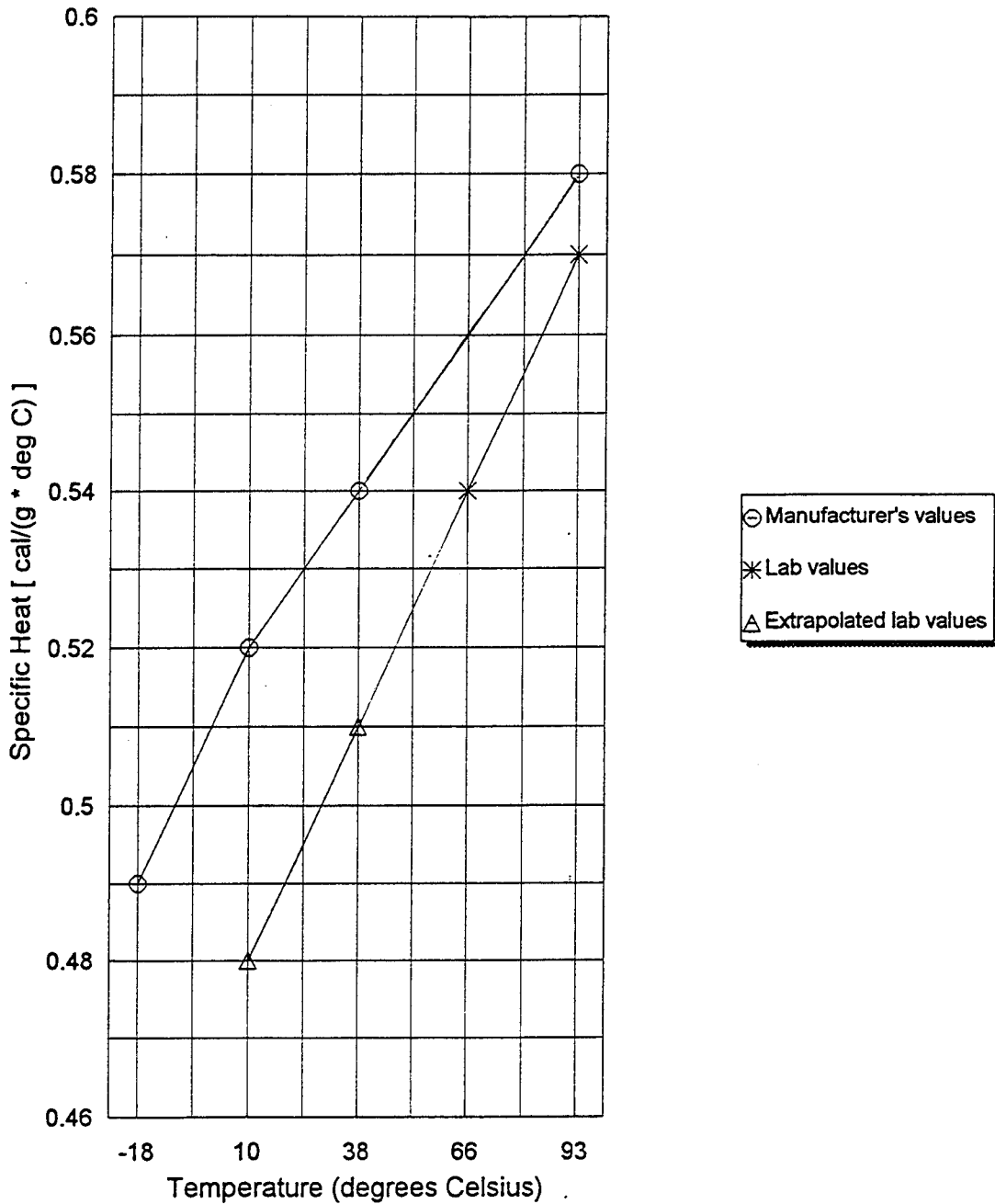

Figure 42. Comparison of specific heat values.

## LIST OF REFERENCES

Beckwith, T. G., Marangoni, R. D., and Lienhard, J. H., Mechanical Measurements, Addison Wesley Publishing Company, Menlo Park, CA, 1983.

Buechler, A. J., and Brough, A. J., "Liquid Flow-Through Module Thermal Evaluation Test Report (NWSC-6043-AECS-3)," Crane Division, Naval Weapons Support Center, Mar. 1992.

Hilbert, W. F., and Kube, F. H., "Effects on Electronic Equipment Reliability of Temperature Cycling in Equipment, Final Report," Grumman Aircraft Engineering Corporation, Report No. EC-69-400, Bethpage, NY, Feb. 1969.

Herold, K. E., Srindar, S., and Hu, S., "Cooling of Electronic Boards Using Internal Fluid Flows," Advances in Electronic Packaging, ASME, 1992.

Kraus, A. D., and Bar-Cohen, A., Thermal Analysis and Control of Electronic Equipment, Hemisphere Publishing Corporation, New York, 1983.

"Brayco Micronic 889 Product Data Sheet," Castrol Specialty Products Division, Irvine, CA, Sep. 1994.

"HP 3852A Data Acquisition/Control Unit, HP 44701A Integrating Voltmeter Accessory Configuration and Programming Manual," Manual No. 44701-90001, Edition 1, Hewlett-Packard Company, Palo Alto, CA, Feb. 1987.



## INITIAL DISTRIBUTION LIST

	No. Copies
1. Defense Technical Information Center Cameron Station Alexandria, Virginia 22304-6145	2
2. Library, Code 52 Naval Postgraduate School Monterey, California 93943-5101	2
3. Professor M. D. Kelleher Department Chairman, Code ME Naval Postgraduate School Monterey, California 93943-5000	3
4. Naval Engineering Curricular Officer, Code 34 Department of Mechanical Engineering Naval Postgraduate School Monterey, CA 93943-5000	1
5. Mr. Kip Hoffer Naval Weapons Support Center Code 6042 Crane, Indiana 47522	1
6. Mr. Tony Buechler Naval Weapons Support Center Code 6042 Crane, Indiana 47522	1
7. Professor Y. Joshi Department of Mechanical Engineering 3147 Engineering Classroom Building University of Maryland College Park, Maryland 20742	1
8. LT William G. Plott 269 Plott Creek Road Waynesville, North Carolina 28786	1