



**US Army Corps
of Engineers**
Construction Engineering
Research Laboratories

USACERL Technical Report EP-95/03
January 1995

Feasibility of White-rot Fungi for Biodegradation of PCP-treated Ammunition Boxes

by
Richard J. Scholze, Richard T. Lamar, Jennifer Bolduc, and Diane Dietrich

Millions of pounds of wood ammunition boxes treated with the wood preservative pentachlorophenol (PCP) are being stockpiled at military installations, primarily depots, because cost-effective disposal is not readily available. The Army needs cost-effective and environmentally benign treatment methods for destruction and disposal of PCP-treated wood products.

This research investigated the use of white-rot fungi to biodegrade PCP-treated wood. Results showed that white-rot fungi effectively decreased the PCP concentration in contaminated hardwood and softwood chips. Under ideal laboratory conditions the fungi reduced the PCP concentration by 80 percent; a field study showed only a 30 percent decrease in PCP concentration. Despite this disparity, this study demonstrated the feasibility of using white-rot fungi to reduce PCP in treated wood.



19950407 147

DTIC QUALITY INSPECTED 5

The contents of this report are not to be used for advertising, publication, or promotional purposes. Citation of trade names does not constitute an official endorsement or approval of the use of such commercial products. The findings of this report are not to be construed as an official Department of the Army position, unless so designated by other authorized documents.

DESTROY THIS REPORT WHEN IT IS NO LONGER NEEDED

DO NOT RETURN IT TO THE ORIGINATOR

REPORT DOCUMENTATION PAGE

Form Approved
OMB No. 0704-0188

Public reporting burden for this collection of information is estimated to average 1 hour per response, including the time for reviewing instructions, searching existing data sources, gathering and maintaining the data needed, and completing and reviewing the collection of information. Send comments regarding this burden estimate or any other aspect of this collection of information, including suggestions for reducing this burden, to Washington Headquarters Services, Directorate for Information Operations and Reports, 1215 Jefferson Davis Highway, Suite 1204, Arlington, VA 22202-4302, and to the Office of Management and Budget, Paperwork Reduction Project (0704-0188), Washington, DC 20503.

1. AGENCY USE ONLY (Leave Blank) 2. REPORT DATE
January 1995 3. REPORT TYPE AND DATES COVERED
Final

4. TITLE AND SUBTITLE
Feasibility of White-rot Fungi for Biodegradation of PCP-treated Ammunition Boxes 5. FUNDING NUMBERS
4A162721
D048
TZ2

6. AUTHOR(S)
Richard J. Scholze, Richard T. Lamar, Jennifer Bolduc, and Diane Dietrich

7. PERFORMING ORGANIZATION NAME(S) AND ADDRESS(ES)
U.S. Army Construction Engineering Research Laboratories (USACERL)
P.O. Box 9005
Champaign, IL 61826-9005 8. PERFORMING ORGANIZATION
REPORT NUMBER
EP-95/03

9. SPONSORING / MONITORING AGENCY NAME(S) AND ADDRESS(ES)
U.S. Army Environmental Center
ATTN: ENAEC-TS
Aberdeen Proving Ground, MD 21010-5401 10. SPONSORING / MONITORING
AGENCY REPORT NUMBER

11. SUPPLEMENTARY NOTES
Copies are available from the National Technical Information Service, 5285 Port Royal Road, Springfield, VA 22161.

12a. DISTRIBUTION / AVAILABILITY STATEMENT
Approved for public release; distribution is unlimited. 12b. DISTRIBUTION CODE

13. ABSTRACT (Maximum 200 words)
Millions of pounds of wood ammunition boxes treated with the wood preservative pentachlorophenol (PCP) are being stockpiled at military installations, primarily depots, because cost-effective disposal is not readily available. The Army needs cost-effective and environmentally benign treatment methods for destruction and disposal of PCP-treated wood products. This research investigated the use of white-rot fungi to biodegrade PCP-treated wood. Results showed that white-rot fungi effectively decreased the PCP concentration in contaminated hardwood and softwood chips. Under ideal laboratory conditions the fungi reduced the PCP concentration by 80 percent; a field study showed only a 30 percent decrease in PCP concentration. Despite this disparity, this study demonstrated the feasibility of using white-rot fungi to reduce PCP in treated wood.

14. SUBJECT TERMS
pentachlorophenol (PCP) hazardous waste
pollutants biodegradation
white-rot fungi 15. NUMBER OF PAGES
66 16. PRICE CODE

17. SECURITY CLASSIFICATION OF REPORT
Unclassified 18. SECURITY CLASSIFICATION OF THIS PAGE
Unclassified 19. SECURITY CLASSIFICATION OF ABSTRACT
Unclassified 20. LIMITATION OF ABSTRACT
SAR

Foreword

This study was conducted for the U.S. Army Environmental Center under Project 4A162721D048, "Industrial Operations Pollution Control Technology"; Work Unit TZ2, "Pentachlorophenol White Rot Fungus." The technical monitor was Richard Eicholtz, ENAEC-TS.

The project was conducted by the Environmental Engineering Division (EP), Environmental Sustainment Laboratory (EL), U.S. Army Construction Engineering Research Laboratories (USACERL). The USACERL principal investigator was Richard J. Scholze. Richard T. Lamar, Jennifer Bolduc, and Diane Dietrich are affiliated with the U.S. Department of Agriculture, Forest Products Laboratory. Appreciation is expressed to Douglas Warnock and innumerable individuals at Letterkenny Army Depot for facilitating the site pilot demonstration. Appreciation is also expressed to Carmen Lebron of the Naval Facilities Engineering Service Center for technical review of this report. Dr. Edgar Smith is Acting Chief, CECER-EP and William Goran is Chief, CECER-EL. The USACERL technical editor was Gloria J. Wienke, Information Management Office.

LTC David J. Rehbein is Commander and Acting Director of USACERL. Dr. Michael J. O'Connor is Technical Director.

Accession For	
NTIS CRA&I	<input checked="" type="checkbox"/>
DTIC TAB	<input type="checkbox"/>
Unannounced	<input type="checkbox"/>
Justification	
By	
Distribution /	
Availability Codes	
Dist	Avail and/or Special
A-1	

Contents

SF 298	1
Foreword	2
List of Figures and Tables	5
1 Introduction	9
Background	9
Objectives	10
Approach	10
Mode of Technology Transfer	11
2 Species Screening and Initial Selection	12
Background	12
Culture Preparation	13
Dry Weight Loss	13
Analytical Procedure	14
Experiment 1	14
Experiment 2	15
Experiment 3	15
Experiment 4	15
Statistical Analysis	16
Results	17
Discussion	24
Conclusions and Recommendations From Initial Studies	27
3 Determination of Optimal Growth Factors for <i>T. hirsuta</i>	28
Materials and Methods	28
Determination of Optimum Growth Temperature and Growth Rates	29
Results and Discussion	31
Conclusions	40
4 Improvement of PCP Wood Extraction Procedure	42
Soil Extraction Procedure Modified for Wood Samples	42
Effect of an Alkaline Extraction Procedure on PCP Recoveries From Wood	42
Effect of Chip Size and Physical Extraction Method	43
Evaluation of Soxhlet Extraction	44
Evaluation of Different Extraction Solvents	44
Effect of Increasing the Number of Extractions	45
New Protocol for Extraction of PCP From Wood	46

5	Liquid Culture Experiments	47
	Determination of Optimal Medium for Growth	47
	Effect of PCP-Treated Wood on <i>T. hirsuta</i> in Liquid Culture	48
	Effect of Preincubation of <i>T. hirsuta</i> in Liquid Culture	48
6	Bioreactor Experiments	50
	Materials and Methods	50
	Effect of Distance From Aeration Source	52
7	Field Evaluation of the Fungal Depletion of PCP-treated Ammunition Boxes .	55
	Field Demonstration Conclusions	58
8	Conclusions and Recommendations	59
	REFERENCES	61

DISTRIBUTION

List of Figures and Tables

Figures

1	Percentage decrease in the PCP concentration of sterile and nonsterile hardwood and softwood chips inoculated with <i>P. chrysosporium</i> (a) or <i>P. sordida</i> (b)	18
2	Accumulation of PCA in sterile and nonsterile hardwood and softwood chips inoculated with <i>P. chrysosporium</i> (a) or <i>P. sordida</i> (b)	19
3	Percentage decrease of PCP	21
4	Schematic of 8L bioreactor	30
5	Effect of temperature on the growth rate of <i>T. hirsuta</i> on 2 percent malt agar	33
6	Effect of PCP on the growth rate of <i>T. hirsuta</i> when aspen wood chips were included in the 2 percent malt agar	33
7	Initial and final concentrations of PCP in large, medium, and small control chips	34
8	Effect of chip size on the concentration of PCP in inoculated chips in HL1 (A), HL2 (B), HL3 (C), and HL4 (D)	36
9	Scanning electron micrograph of PCP-treated softwood	37
10	Effect of inoculum type on the concentration of PCP in inoculated chips at the various harvest levels	40
11	Comparison of 0.5 N Sodium Hydroxide to Hexace solvent for extraction of PCP from wood	43
12	Effect of varying sizes of wood chips and sonication versus tumbler-shaker rotation on the extractability of PCP from wood	44

13	Effect of methanol, hexane, acetone, and hexane on the extractability of PCP from wood	45
14	Effect of increasing the number of extractions on the recovery of PCP from wood	45
15	Effect of 1.5% malt extract, YMPG, G/P and B _{III} compared to shaking versus stationary incubation on the mycelial weights of <i>T. hirsuta</i>	47
16	Effect of varying levels of PCP-treated ground wood with stationary incubation on the mycelial weights of <i>T. hirsuta</i>	49
17	8-Liter bioreactor	51
18	Effect of inoculation rate on PCP concentration in wood chips after 4 weeks incubation in an 8-L bioreactor	52
19	Side A of the bioreactor	53
20	Side B of the bioreactor	54
21	Experimental site	56
22	Effect of incubation time of <i>T. hirsuta</i> versus levels of PCP from the wood chips	57
23	Effect of time on the ergosterol level present in the wood chips	58

Tables

1	Initial and final concentrations of PCP and PCA in chips supplemented with different carbon and nitrogen sources	20
2	Concentrations of PCP and PCA in sterile softwood chips inoculated with <i>Trametes hirsuta</i> or left noninoculated	21
3	Concentrations of PCP and PCA in sterile softwood chips inoculated with <i>Ceriposioopsis subvermispora</i> or left non-inoculated	22

4	Concentrations of PCP and PCA in sterile softwood chips inoculated or not with <i>Trametes hirsuta</i>	22
5	Percentage recoveries of ^{14}C [PCP] from sterile softwood chips inoculated or not with <i>T. hirsuta</i>	23
6	Effect of wood type and sterilization on the percentage dry weight loss of PCP-contaminated wood chips	23
7	Effect of different carbon and nitrogen sources on percentage dry weight loss after 3 weeks on PCP-contaminated softwood chips inoculated with <i>P. chrysosporium</i>	24
8	Percentage dry weight loss, 14 and 28 days after inoculation, of sterile softwood chips inoculated with <i>T. hirsuta</i> or <i>Ceriporiopsis subvermispota</i> or left noninoculated	24
9	Effect of chip size and harvest level on the concentration of PCP in chips inoculated with <i>T. hirsuta</i> after 6 weeks	35
10	Initial PCP concentrations in small, medium, and large chips and PCP concentrations in small, medium, and large control chips at the three harvest levels after 4 weeks	39
11	Effect of inoculum type, chip size, and harvest level on the concentration of PCP in inoculated chips after 4 weeks	39

1 Introduction

Background

Millions of pounds of wood ammunition boxes treated with pentachlorophenol (PCP) are being stockpiled at military installations, primarily depots, because cost-effective disposal is not readily available. PCP is a toxic organic used as a wood preservative. Although new wood preservatives have been in use for several years, the Army has a considerable inventory of PCP-treated boxes. Disposal off-site through giveaway or Defense Reutilization and Marketing Office (DRMO) programs does not eliminate potential legal liability. Additionally, state regulations on disposal of this waste vary; some state regulations are more restrictive than Federal regulations. In some states, landfilling is permitted only at certified hazardous waste landfill sites and incineration is permitted only at hazardous waste incinerators where there is the potential for generating dioxins during combustion.

Although PCP has been classified as a priority pollutant, PCP-treated wood products are currently disposed of as ordinary solid (nonhazardous) wastes in many states. Unregulated disposal of these materials is allowed because concentrations of PCP in extracts from PCP-treated wood products such as poles and crossarms, determined by the Toxicity Characteristic Leaching Procedure (TCLP) (Electric Power Research Institute [EPRI] 1990), have been shown to be well below the 100 mg/L PCP criterion used to classify these materials as hazardous wastes under the Resource Conservation and Recovery Act (RCRA) (Code of Federal Regulations [CFR] 1990). Because the solubility of PCP in water at the pH of the TCLP leachate is only 17 mg/L, no PCP-treated wood products will be classified as hazardous until the regulatory level is lowered. There has been some discussion within the U.S. Environmental Protection Agency (USEPA) of lowering the TCLP level to 100 µg/L to be consistent with the current regulatory level for drinking water. In this case, almost all PCP-treated wood products would be classified as hazardous wastes. The compound is a teratogen and suspected carcinogen. Moreover, recent research demonstrating that technical grade mixtures of PCP are carcinogenic to certain types of laboratory mice (National Toxicology Program 1989) may result in a decrease in the allowable limits of PCP to levels that would in turn result in reclassification of PCP-treated wood products as hazardous wastes. In anticipation of this reclassification, the U.S. Army currently stockpiles PCP-treated ammunition boxes rather than disposing of them.

It is difficult to determine the amount of PCP-treated wood being stockpiled. The U.S. Army Materiel Command (USAMC), primary user of ammunition boxes, does not have exact figures on the extent, but the 8th Army in Korea returns approximately 30,000 boxes per year to the United States. The M-16 rounds needed to qualify today's fighting forces would require 20,000 boxes and cost \$259,000 to dispose. This does not reflect rounds required during training or the many other forms of ammunition required by today's Army in international activities.

The Army needs cost-effective and environmentally benign treatment methods for destruction and disposal of PCP-treated wood products. One area of investigation is the use of biological processes, which are generally more cost-effective than physical or chemical treatment processes where appropriate. Biological organisms that degrade pentachlorophenol include fungal species and bacteria. This research focused on white-rot fungi because they have the potential to not only mineralize the PCP but also to reduce the wood mass (Mileski 1988; Lamar and Dietrich 1992).

Objectives

The objectives of this study were to:

1. Evaluate species of white-rot fungi to determine the best species for PCP-treated wood degradation,
2. Determine optimum critical environmental parameters and growth conditions along with factors permitting demonstration at a large-scale operation,
3. Demonstrate on a large scale the feasibility of using white-rot fungi for biodegradation of PCP-treated ammunition boxes,
4. Determine the fate of PCP in wood chips after inoculation with white-rot fungi, and
5. Determine the overall feasibility of biodegradation of PCP-treated ammunition boxes and pallets with the use of white-rot fungi.

Approach

Researchers conducted a literature review, a comprehensive battery of experiments, and an expanded scale evaluation of the applicability of white-rot fungi. Appropriate species were screened to determine the most appropriate species for biodegradation of PCP-treated ammunition boxes. Determination of critical parameters resulted from a battery of laboratory-scale investigations. Parameters such as aeration, humidity, wood chip size, temperature, and inoculum application were examined. Operating

conditions for a field application were developed. Appropriate analytical tools were created or developed, such as improved extraction procedures. A small-scale field trial at a military installation was conducted.

Mode of Technology Transfer

It is recommended that the information in this report be used for a pilot scale demonstration of biodegradation of PCP-treated wood. Information has been disseminated to the U.S. Army Corp of Engineers for the Site Remediation Technology Handbook.

2 Species Screening and Initial Selection

Background

The ability to degrade both wood and PCP makes white-rot fungi good candidates for use in destroying PCP-treated wood products. White-rot fungi are a group (more than 1500 species) of filamentous wood-decay fungi, primarily basidiomycetes with some ascomycetes, that share the ability to simultaneously metabolize lignin and the polysaccharide components of wood. They are the major degraders of fully lignified tissues (lignin content greater than or equal to 20 percent) and therefore play a vital role in the recycling of photosynthetically-fixed carbon. They are capable of degrading a variety of xenobiotics (recalcitrant chemicals) including pentachlorophenol in aqueous media and soils, and several species, including *Phanerochaete chrysosporium*, can degrade chlorinated organics. Because of the large number of white-rot fungi, a selection process was necessary to determine the most appropriate species for biodegradation of PCP-treated ammunition boxes.

The first set of experiments was designed to screen potential white-rot fungi. Several fungal species were used because ammunition boxes contain both hardwoods and softwoods. *Phanerochaete chrysosporium*, *Phanerochaete sordida*, *Ceriporiopsis subvermispora*, and *Trametes hirsuta* were evaluated for softwood and the two *Phanerochaete* species were evaluated for decomposition of hardwood.

P. chrysosporium and *P. sordida* were included in this screening phase because of the ability of *P. chrysosporium* to transform PCP in aqueous media (Lamar, Larsen, and Kirk 1990; Lin, Wang, and Hickey 1990; Mileski et al. 1988) and of both organisms to transform PCP in soil (Lamar and Dietrich, 1990; Lamar, Glaser, and Kirk, 1990; Lamar, Larsen, and Kirk, 1990). *T. hirsuta* and *C. subvermispora* were included in this study because of their superior abilities to effect large weight losses in both hardwood and softwood materials (Otjen et al. 1987). Lignin-degrading fungi are more frequently associated with hardwood hosts (Nobles 1965) and are usually able to cause greater weight losses in hardwood compared to softwood.

Six PCP-treated ammunition boxes were used for testing. Three were nailed pine boxes constructed mostly of lodgepole or ponderosa pine panels and yellow poplar end cleats. Three were wire-bound, constructed of hardwood, mostly blackgum and

sweetgum panels with yellow poplar end cleats. The boxes were disassembled and the hardwood and softwood materials separated. The material was chipped, using a hammer mill, to pass a 3.8-cm screen and stored in plastic bags at 4 °C. Sterile chips were prepared by adjusting the moisture content of the chips to 60 percent with distilled water and autoclaving at 121 °C for 30 minutes on 3 consecutive days.

Each fungus was grown and maintained on yeast-malt-peptone-glucose (YMPG) agar on slants. For each fungus, inoculum plates were prepared by aseptically transferring pieces of fungal mycelium from YMPG slants to 2 percent malt agar plates (100 mm x 20 mm). The fungi were kept at their incubation temperature until colony growth completely covered the plates. Incubation temperatures for experimental cultures were as follows: *P. chrysosporium* 39 °C; *P. sordida* 30 °C; *T. hirsuta* and *C. subvermispora* 27 °C. Incubation temperatures during experiments were the same except for *P. chrysosporium*, which was incubated at 30 °C.

Culture Preparation

Chip cultures were prepared by aseptically placing about 10 grams (g) chips (dry weight) in an aluminum foil-covered 125-milliliter (ml) Erlenmeyer flask (Experiment 1) or in a 272-ml canning jar with a modified cover (Experiments 2 and 3). Covers were modified to allow adequate air exchange by gluing a piece of microporous material over a 0.32-centimeter (cm) hole on the inside of the cover. Erlenmeyer flasks and canning jars were sterilized by autoclaving at 121 °C for 15 minutes. Canning jar covers were sterilized by fumigation with methyl bromide. Fungal cultures were prepared by aseptically adding pieces of 2 percent malt agar infested with the appropriate fungus to the chips. Approximately half of the agar from an inoculum plate (about 8 g) was added per culture.

Dry Weight Loss

Percentage dry weight loss of chips was determined using the following formula: $[(\text{initial chip dry weight} - \text{chip harvest dry weight}) / \text{initial dry weight}] \times 100$. Harvest wet weight of chips from fungal inoculated cultures was determined after removing mycelium from chip surfaces. Harvest dry weight was then determined after drying a sample of the chips at 105 °C for 24 hours to determine moisture content gravimetrically.

Analytical Procedure

The PCP and pentachloroanisole (PCA) concentration of the chips was determined using the following procedure: For Experiment #1, about 5-g chip subsamples were placed in 25 x 150 mm culture tubes with teflon-lined screw caps. For experiments #2-4, chips were ground in a commercial coffee grinder before extraction. Approximately 4 g of ground chips were then placed in the culture tubes. Replicate determinations were performed per culture for PCP and PCA analysis. A sample was also taken to determine moisture content of the chips or ground chips, gravimetrically. Approximately 100 mg of $\text{Na}_2\text{S}_2\text{O}_4$ were added to each tube. Chip samples were then extracted for 1 hour on a rotating tumbler shaker with two 20-ml volumes of a mixture of hexane-acetone (1:1) acidified to pH 2 with concentrated H_2SO_4 . The extracts were pooled in a clean tube and dried by passing them through a column of anhydrous Na_2SO_4 . The Na_2SO_4 was prepared by muffling for 4 hours at 400 °C and storing over desiccant. Drying tubes and culture tubes were muffled for 1 hour at 450 °C before use. Culture tubes containing the extracts were placed in an evaporator held at 30 °C and the extracts evaporated to approximately 5 ml under nitrogen. The 5 ml was then transferred with a hexane rinse to a 10-ml volumetric flask and the extract volume adjusted to 10 ml with hexane. Extracts were stored at -20 °C under nitrogen in amber vials with teflon-lined screw caps.

Extracts were analyzed by gas chromatography with electron capture detector (GC-ECD) for PCP and PCA. PCP was analyzed as the trimethylsilyl derivative and quantified with derivatized standards. PCA was quantified nonderivatized with authentic standards. Gas chromatographic analyses of extracts were performed. Operating temperatures were 220 °C for the injector and 300 °C for the detector. The carrier gas was He and the make-up gas N_2 . The column was a 30-m x 0.321- μm DB-5 fused silica capillary column, film thickness 0.25 μm . The temperature program was initial 60 °C, hold for 1 minute, split off for 1 minute, ramp A, 10 degrees per min for 9 minutes (60 °C to 150 °C), ramp B, 2 degrees per min for 20 minutes (150 °C to 190 °C), and hold at 190 °C for 5 minutes.

Experiment 1

In Experiment 1, PCP-contaminated softwood and hardwood chips were inoculated with *P. chrysosporium* or *P. sordida*. Weight loss and concentrations of PCP and PCA were determined. Sterile and nonsterile chips were supplemented with 5000 parts per million (ppm) glutamine and inoculated or left noninoculated. Cultures were incubated at 30 °C. Initial concentrations of PCP and PCA were determined on 10 replicate samples from each batch of sterile or nonsterile hardwood and softwood chips.

Percentage dry weight losses and concentrations of PCP and PCA were determined at 1, 2, 4, and 6 weeks. In addition, percentage dry weight losses were determined at 9 weeks. Analyses were performed in duplicate on five cultures per treatment at each sample time.

Experiment 2

In Experiment 2, softwood chips were inoculated with *T. hirsuta* or *C. subvermispora*. Weight loss and PCP and PCA concentrations were evaluated. Evaluation of each fungus was performed using a separate batch of softwood chips. The chips were sterilized by autoclaving, amended with 5000 ppm glutamine and inoculated with *T. hirsuta* or *C. subvermispora* or left noninoculated for controls. Initial concentrations of PCP and PCA were determined on 10 replicate samples for each batch of chips. Percentage dry weight loss and concentrations of PCP and PCA were determined after 2 and 4 weeks of incubation. Replicate analyses were performed on six cultures per treatment at each sample time.

Experiment 3

Experiment 3 investigated the effects of different carbon and nitrogen source supplementations on the concentrations of PCP and PCA in softwood chips inoculated with *P. chrysosporium*. The final concentration of the supplements in $\mu\text{g/g}$ of chips was based on the equivalent amount of either carbon or nitrogen supplied by 5000 μg glutamine/g chips. Each of six batches of chips taken from a common batch was supplemented with either glucose, glycerin, NH_4Cl , glutamine, KNO_3 , or no supplement. Initial concentrations of PCP and PCA were determined on 5 replicate samples from each batch of chips. Three inoculated and two noninoculated cultures were prepared from each treatment. Weight losses and concentrations of PCP and PCA in sterile softwood chips were determined on duplicate samples from each culture after 3 weeks.

Experiment 4

In Experiment 4, the fate of PCP in sterile softwood chips inoculated with *T. hirsuta* or left noninoculated as control, was determined. The moisture content of the chips was adjusted to 60 percent with deionized water after which the chips were autoclaved at 121 °C and aseptically placed in sterile 125-ml Erlenmeyer flasks (about 4 g chips/flask). The sterilized chips in each flask were then spiked with about

600,000 disintegrations per minute (dpm) of ^{14}C -labeled PCP in 0.5 ml of DMF (N,N-Dimethyl formamide) and autoclaved a second time. Fungal cultures were inoculated as in previous experiments. Control cultures consisted of noninoculated chips. Six cultures were prepared for each treatment. Cultures were incubated at 30 °C for 28 days.

To assess losses of PCP by mineralization or volatilization and to aerate the cultures, the 125-ml Erlenmeyer flasks were fitted with inlet-outlet ports. Ports were protected from contamination by sterile, silanized glass wool traps. Outlet ports were connected to volatile traps that were connected in turn to manifold assemblies that directed evolved CO_2 into 10 ml of CO_2 -trapping scintillation mixture. The mixture was composed of toluene cocktail, methanol, and ethanolamine (v:v:v, 5:4:1). The toluene cocktail contained 4 g/L POP (2,5-diphenyloxazole) and 0.1 g/L POPOP (p-bis-[2-(5-Phenyl)-oxazole] benzene) in toluene.

Headspace of all cultures were flushed with humidified air every 3 to 4 days. The first flushing was conducted 3 days after inoculation. After each flushing, the amount of trapped $^{14}\text{CO}_2$ was determined by transferring the 10 ml of scintillation mixture to a 20-ml scintillation vial for counting. ^{14}C volatiles were determined at the termination of the experiment by measuring the ^{14}C contents of two 0.25-ml aliquots of a 2-ml hexane extract of the ORBO tube packing material. The aliquots were transferred to 10 ml of scintillation cocktail.

Initial concentrations of PCP and PCA were determined on 10 4-g samples of chips that were not amended with ^{14}C [PCP] but that were taken from a common batch and treated identically to the chips used to prepare the cultures. Final concentrations of PCP and PCA were determined as described in the analytical section with the following exception. The amount of organic extractable ^{14}C was determined by measuring the amount of ^{14}C associated with two 1-ml aliquots from the pooled hexane-acetone extract volume, before evaporation. Nonextractable ^{14}C (^{14}C associated with the organic extracted chips) was determined by combustion of two 0.1-g samples from each sample of previously extracted chips. Radioactivity from the evolved CO_2 was determined by allowing the agar to air dry, followed by combustion and liquid scintillation counting as described for the chips.

Statistical Analysis

Data for concentrations of PCP and PCA and percentage weight loss were determined by analysis of variance, and differences among means were determined using Scheffe's

test ($\alpha = 0.05$). Percentage decreases in the PCP concentration were determined by using the concentration found in identical noninoculated cultures as the base.

Results

Concentrations of PCP and PCA

Experiment 1 (inoculation of sterile and nonsterile softwood or hardwood chips with either *P. chrysosporium* or *P. sordida*) resulted in decreases in the PCP concentrations of the chips ranging from 30 to 72 percent after 6 weeks (Figure 1). No decreases in PCP concentrations were observed in either sterile or nonsterile noninoculated chips, indicating that observed PCP decreases were due to the activities of the fungi. Decreases of PCP by either fungus were not significantly influenced by wood type.

Decreases in the PCP concentration in hardwood and softwood chips inoculated with *P. chrysosporium* were rapid and extensive (63 to 72 percent decrease after 6 weeks), except in nonsterile softwood chips (Figure 1). Most depletion in sterile hardwood and softwood, and nonsterile hardwood chips occurred during the second week of incubation. In nonsterile softwood chips, depletion of PCP was relatively slow and resulted in only a 30 percent decrease after 42 days. However, a slow but steady increase occurred in the percentage of PCP decrease between days 14 and 42.

Depletion of PCP by *P. sordida* was greatly affected by sterilization. Inoculation of nonsterile softwood and hardwood chips resulted in only a 50 and 45 percent decrease in the PCP concentration, respectively, after 42 days (Figure 1). However, the PCP concentration in both hardwood and softwood chips that had been sterilized was decreased by about 66 percent by *P. sordida* after 42 days. As was observed with *P. chrysosporium*, most of the PCP decrease occurred during the second week of incubation, except in nonsterile hardwood chips where the majority of the decrease occurred between days 28 and 42.

Depletion of PCP was always accompanied by formation of PCA (Figure 2). No accumulation of PCA was observed in noninoculated cultures, indicating that accumulation in inoculated chips was due to the activity of the fungi. Accumulation of PCA in sterile cultures was much greater than in nonsterile cultures of both fungi. This was particularly true for cultures inoculated with *P. sordida*. Only 7 and 19 percent of the PCP decrease in nonsterile softwood and hardwood chips, respectively, was due to conversion of PCP to PCA. However, this low rate of conversion was associated with relatively low amounts of total PCP depletion.

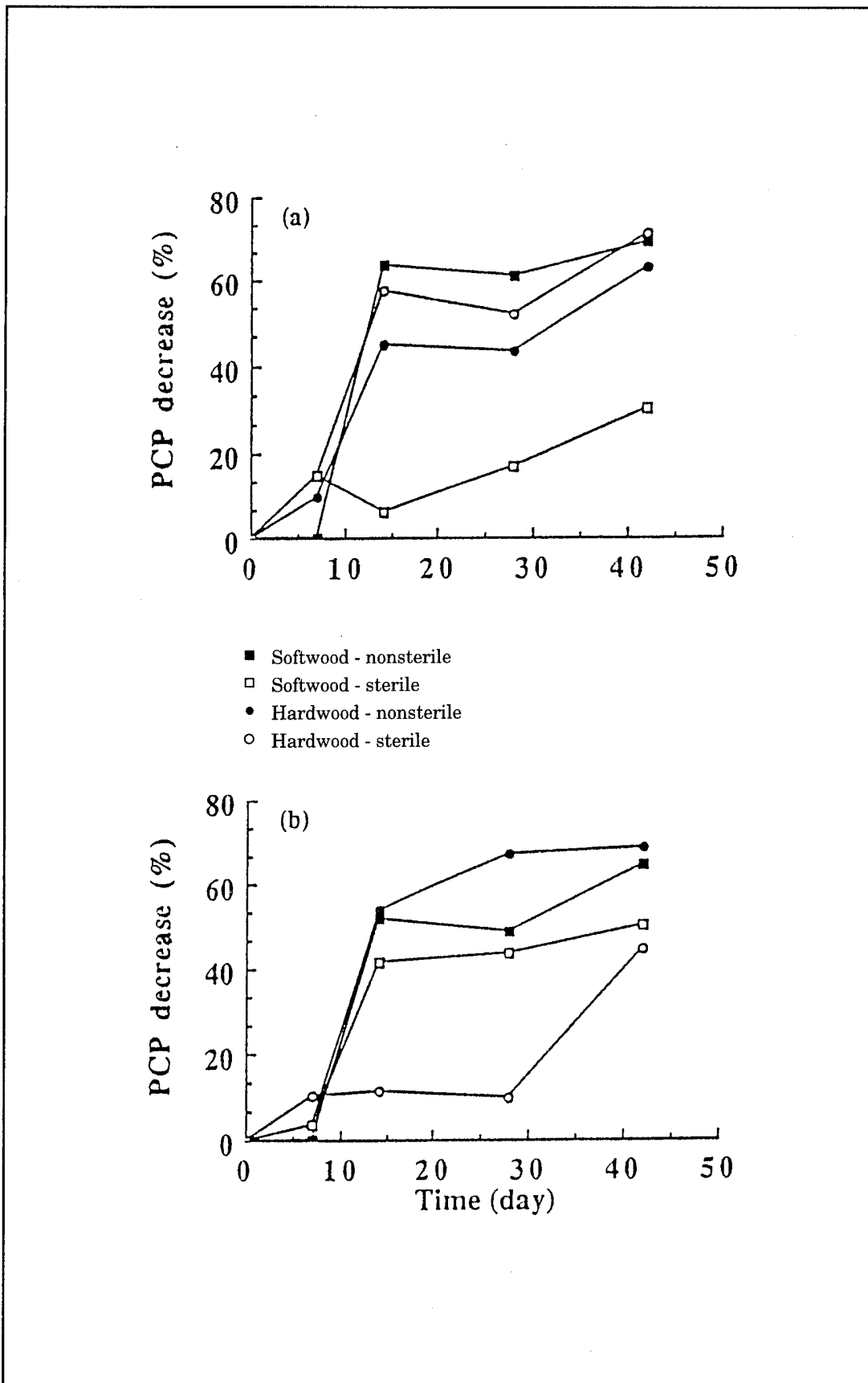

Figure 1. Percentage decrease in the PCP concentration of sterile and nonsterile hardwood and softwood chips inoculated with *P. chrysosporium* (a) or *P. sordida* (b).

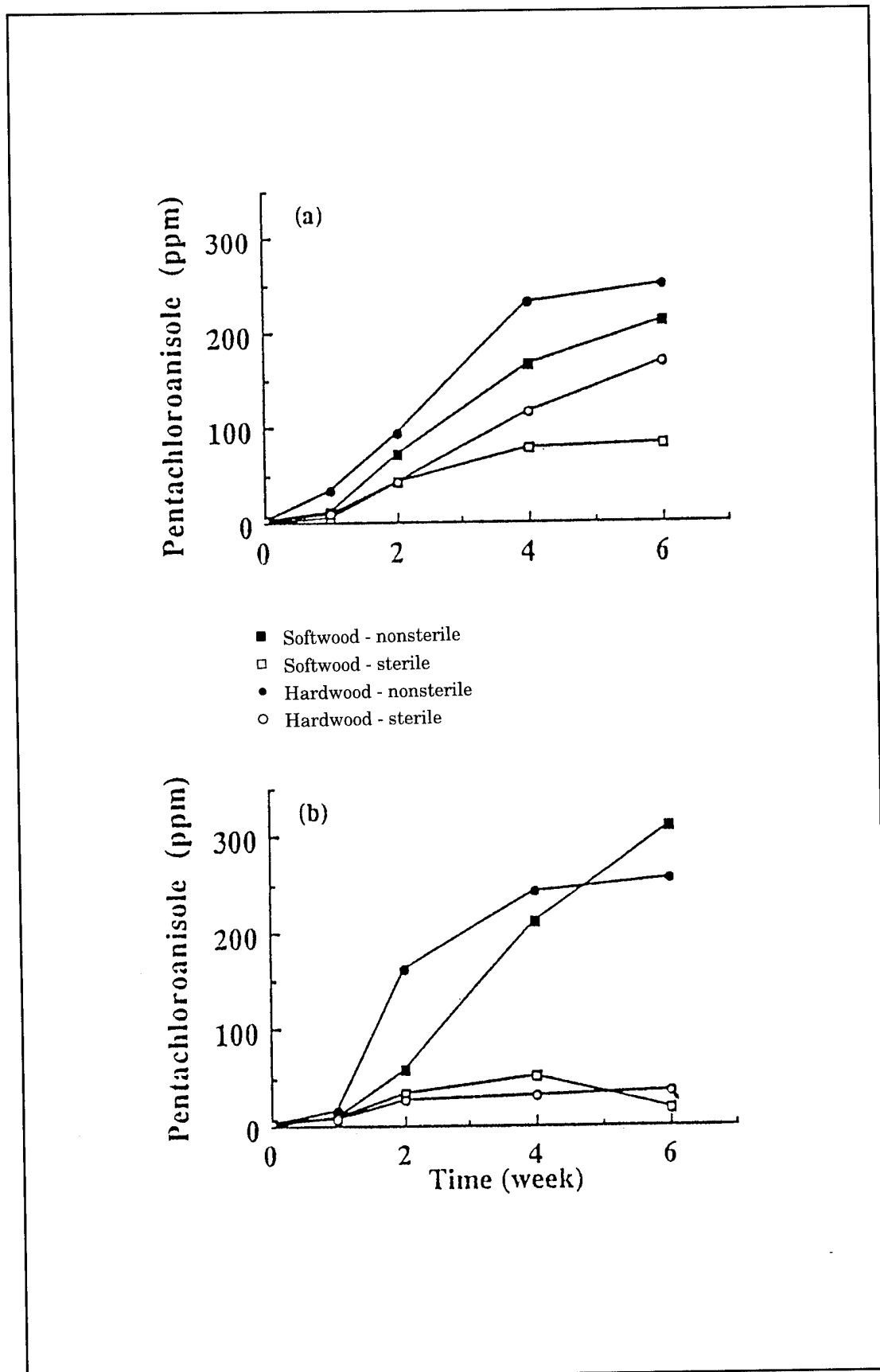

Figure 2. Accumulation of PCA in sterile and nonsterile hardwood and softwood chips inoculated with *P. chrysosporium* (a) or *P. sordida* (b).

In nonsterile hardwood and softwood chips inoculated with *P. chrysosporium*, 65 and 72 percent, respectively, of the PCP decrease was due to conversion of PCP to PCA.

In sterile chips inoculated with either fungus, virtually all of the PCP decrease was due to conversion to PCA.

In Experiment 3, the initial PCP concentration in the chips averaged 367 µg/g, except in chips supplemented with glutamine (Table 1). Extraction of chips supplemented with glutamine appeared to have a significantly higher initial PCP concentration. However, after 3 weeks, the extractable PCP concentration in noninoculated chips increased in all cases, except in chips supplemented with glutamine.

There was a decrease in the PCP concentration in inoculated chips regardless of the supplement treatment. Treatment with glucose showed the highest percentage decrease, followed by glutamine, which showed the same decrease as no supplement. Glycerin showed the next percent decrease, followed by KNO₃ and NH₄Cl, which showed the same decrease.

Decreases in PCP concentration were always accompanied by increases in PCA concentration (Table 1). However, the percentage of the total decrease in the PCP concentration as a result of PCA formation varied greatly among the treatments (Figure 3). When chips were supplemented with glycerin, virtually all (99.05 percent) of the PCP decrease was due to conversion to PCA. In chips receiving inorganic sources of nitrogen, the majority (77 to 89 percent) of the PCP loss was due to conversion of PCP to PCA. Finally, in chips supplemented with glucose or glutamine and in chips receiving no supplement, slightly less than two-thirds (61 to 63 percent) of the PCP decrease was due to conversion to PCA.

Table 1. Initial and final concentrations of PCP and PCA in chips supplemented with different carbon and nitrogen sources.

Supplement	PCP (µg/g)				Decrease (percent)	PCA (µg/g)		
	Initial	Inoculated	Noninoculated	Initial		Inoculated	Noninoculated	
Glucose	403.7 ^b	125.5 ^a	463.1 ^a	72.9	5.3 ^b	207.3 ^{ab}	8.4 ^a	
Glycerin	366.6 ^b	195.4 ^{ab}	418.2 ^a	53.3	11.3 ^a	220.7 ^a	6.1 ^b	
NH ₄ Cl	337.9 ^b	295.1 ^c	539.2 ^a	45.3	5.3 ^b	189.0 ^{ab}	4.1 ^{bcd}	
Glutamine	551.3 ^a	175.7 ^{ab}	529.8 ^a	66.8	4.1 ^b	221.1 ^a	4.0 ^{cd}	
KNO ₃	333.8 ^b	237.3 ^{bc}	441.3 ^a	46.2	3.9 ^b	181.9 ^b	5.8 ^{bc}	
Nothing	394.2 ^b	196.7 ^{ab}	509.5 ^a	61.4	3.9 ^b	198.6 ^{ab}	3.1 ^d	

^a Means within columns followed by the same letter are not significantly different according to Scheffe's test ($\alpha = 0.05$).

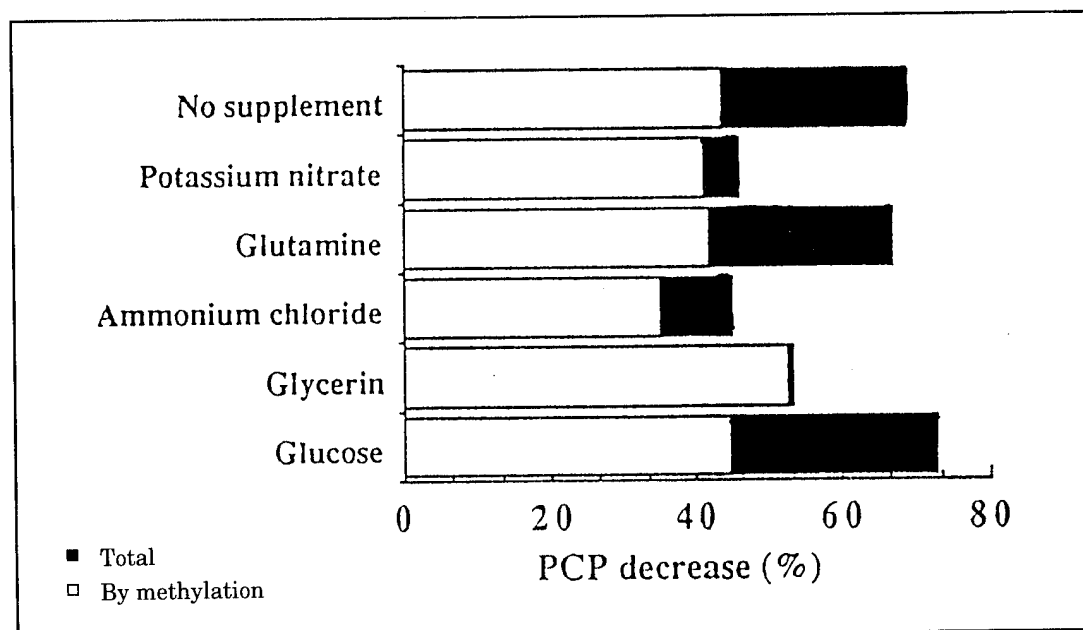

Figure 3. Percentage decrease of PCP.

Experiment 2 (inoculation of sterile PCP-contaminated softwood chips with *T. hirsuta*) resulted in a decrease in the PCP concentration from 382 $\mu\text{g/g}$ to 145 $\mu\text{g/g}$ (Table 2). This represented a 62 percent decrease in the amount of PCP found in noninoculated cultures after 4 weeks. This percentage decrease is similar to and greater than the amount of PCP removed by *P. chrysosporium* and *P. sordida*, respectively, after 4 weeks. However, the decrease affected by *T. hirsuta* was not due to conversion of PCP to PCA as it was in chips inoculated with *P. chrysosporium* or *P. sordida*. Although the amount of PCA increased slightly in inoculated cultures (Table 2), the amount of accumulation represented only a fraction of a percent of the amount of PCP removed.

Inoculation of PCP-contaminated softwood chips with *C. subvermispora* resulted in a decrease in the concentration of PCP from 448 $\mu\text{g/g}$ to 266 $\mu\text{g/g}$ after 4 weeks (Table 3). This 37 percent decrease was the least of any of the fungi evaluated. However, no accumulation of PCA in inoculated cultures indicated that, as was observed with *T. hirsuta*, the decrease was not due to conversion of PCP to PCA (Table 3).

Table 2. Concentrations of PCP and PCA in sterile softwood chips inoculated with *Trametes hirsuta* or left noninoculated.

Fungus	PCP ($\mu\text{g/g}$)			PCA ($\mu\text{g/g}$)		
	Day					
	0	14	28	0	14	28
<i>T. hirsuta</i>	381.69 ^a	240.98 ^b	145.39 ^c	2.80 ^a	2.27 ^a	4.41 ^c
Noninoculated	381.69 ^a	353.27 ^a	355.46 ^a	2.80 ^a	1.75 ^{ab}	1.30 ^b

^a Means followed by the same letter are not significantly different according to Scheffe's test ($\alpha = 0.05$).

Table 3. Concentrations of PCP and PCA in sterile softwood chips inoculated with *Ceriposiopsis subvermispora* or left noninoculated.

Fungus	PCP ($\mu\text{g/g}$)			PCA ($\mu\text{g/g}$)		
	Day					
	0	14	28	0	14	28
<i>C. subvermispora</i>	448.0 ^a	300.0 ^b	266.1 ^c	5.1 ^a	4.4 ^a	6.2 ^a
Noninoculated	448.0 ^a	408.9 ^a	418.9 ^a	5.1 ^a	4.1 ^a	3.6 ^a

^a Means within compound followed by the same letter are not significantly different according to Scheffe's test ($\alpha = 0.05$).

Fate of PCP in Sterile Softwood Chips Inoculated With *Trametes hirsuta*

In Experiment 4, inoculation of sterile softwood chips with *T. hirsuta* resulted in an 84 percent decrease in the PCP concentration over what was found in noninoculated chips after 4 weeks (Table 4). As was observed previously with this fungus, the decrease in the PCP concentration was not due to conversion of PCP to PCA. Indeed, the level of PCA significantly decreased in inoculated compared to noninoculated chips (Table 4).

Total recoveries of ¹⁴C in the mass balance analysis averaged 98.65 percent from inoculated cultures and 96.36 percent from noninoculated cultures (Table 5). In inoculated cultures, 27 percent of the PCP was mineralized, 43 percent was nonextractable and associated with the chips, 24 percent was associated with the residual pieces of malt agar and fungal hyphae, and the remaining 6 percent was organic extractable. In noninoculated cultures, the bulk (80 percent) of the ¹⁴C was found in the organic extract. Approximately 16 percent was nonextractable and associated with the chips. The amount of ¹⁴C lost by volatilization was negligible in both inoculated and noninoculated cultures.

Dry Weight Loss

After 9 weeks, the percentage dry weight loss of wood chips was significantly affected by fungal species (statistical probability, $p = 0.0314$) but not by sterilization treatment

Table 4. Concentrations of PCP and PCA in sterile softwood chips inoculated or not with *Trametes hirsuta*.

	Initial	Concentration ($\mu\text{g/g}$) after 4 weeks	
		Inoculated	Noninoculated
PCP	212.0 ^a	39.9 ^b	255.0 ^a
PCA	3.2 ^a	1.7 ^b	3.2 ^a

^a Means within rows followed by the same letter are not significantly different according to Scheffe's test ($\alpha = 0.05$).

Table 5. Percentage recoveries of ^{14}C [PCP] from sterile softwood chips inoculated or not with *T. hirsuta*.

	^{14}C Recovered (percent) ^a					Total
	Mineralization ^b	Volatilization	Organic Extractable ^c	Chips ^d	Fungal Hyphae	
Inoculated	27.23	0.00	5.48	42.49	23.45	98.65
Noninoculated	0.01	0.00	80.21	16.14	NA	96.36

^a Percentage recoveries represent the means of six replicates.
^b Evolved and collected as ^{14}C -CO₂.
^c Extracted in a mixture of hexane:acetone (50:50) acidified to pH 2.
^d Residual ^{14}C associated with the chips after organic extraction.

($p = 0.1276$) or by wood type ($p = 0.9520$). Overall, *P. chrysosporium* caused an average 17.8 percent weight loss compared to 12 percent for *P. sordida*. Although sterilization treatment did not affect percentage weight loss significantly, weight loss was always greater in sterile than in nonsterile chips, except in softwood chips inoculated with *P. chrysosporium* (Table 6). No weight loss was observed in noninoculated chips.

Supplementing softwood chips with different sources of carbon and nitrogen increased the percentage dry weight loss affected by *P. chrysosporium* over that observed in chips receiving no supplement (Table 7) in all but one case (glycerin). The extent of the percentage weight loss varied greatly with the supplement. The greatest percentage dry weight loss was obtained in chips supplemented with glutamine. However, the weight loss obtained with supplemental glutamine was not significantly different than that obtained when glucose or NH₄Cl was used as a supplement. Percentage dry weight loss was very low when KNO₃ or glycerin was used as a supplement and when the chips were not supplemented.

Inoculation of softwood chips with *T. hirsuta* resulted in a 25 percent weight loss after 4 weeks (Table 8). This weight loss was much greater than that obtained from inoculation with *P. chrysosporium* or *P. sordida* after 9 weeks (Table 6). After 4 weeks, *C. subvermispora* decreased the dry weight of the PCP-contaminated softwood chips

Table 6. Effect of wood type and sterilization on the percentage dry weight loss of PCP-contaminated wood chips.

Fungus	Dry weight loss (percent)				Overall mean
	Hardwood		Softwood		
	+	-	+	-	
<i>P. chrysosporium</i>	21.3	14.0	18.0	18.1	17.8
<i>P. sordida</i>	13.6	9.2	14.9	14.5	11.4
Noninoculated	0.0	0.4	0.1	0.6	0.3

^a + is sterile; - is nonsterile.

Table 7. Effect of different carbon and nitrogen sources on percentage dry weight loss after 3 weeks on PCP-contaminated softwood chips inoculated with *P. chrysosporium*.

Carbon or nitrogen source	Dry weight loss (percent)
Glutamine	11.68 ^a
NH ₄ Cl	9.49 ^{ab}
Glucose	8.33 ^{ab}
KNO ₃	4.53 ^{bc}
Glycerin	1.46 ^{bc}
No supplement	2.50 ^{bc}
^a Means followed by the same letter are not significantly different according to Scheffe's multiple comparison test ($\alpha = 0.05$).	

by 17 percent (Table 8). This loss was greater than those obtained from inoculation with *P. chrysosporium* or *P. sordida* (Table 6) but less than that obtained with *T. hirsuta*. No weight loss was observed in noninoculated chips (Table 8).

Discussion

Using lignin-degrading fungi to dispose of PCP-treated wood products would seem to be contradictory, because the PCP is applied to wood to prevent the growth of these organisms. However, the results of this first set of experiments demonstrate that once the protective barrier of PCP in the wood is disrupted by chipping the treated wood to expose the nontreated portion, lignin-degrading fungi have the ability to colonize the wood and to rapidly deplete a large percentage of the PCP. Along with their ability to transform PCP, a key factor in contributing to the depletion of PCP by these organisms is their rapid and extensive colonization of the wood. This colonization gives them access to the PCP deposited in the wood cell walls and cell lumens during application.

Table 8. Percentage dry weight loss, 14 and 28 days after inoculation, of sterile softwood chips inoculated with *T. hirsuta* or *Ceriporiopsis subvermispota* or left noninoculated.

Fungus	Weight loss (percent)	
	14 day	28 day
<i>Trametes hirsuta</i>	12.37	24.49
Noninoculated	0.71	0.84
<i>Ceriporiopsis subvermispota</i>	6.32	17.4
Noninoculated	0.06	1.61

The *Phanerochaete* species were shown to decrease PCP quite rapidly and extensively in the ammunition box wood. However, the decrease was generally due to methylation of PCP resulting in accumulation of PCA, a major PCP transformation product of these fungi (Lamar and Dietrich 1990; Lamar, Glaser, and Kirk 1990). No evidence existed for decreases of PCA after it had accumulated in wood chips inoculated with *P. chrysosporium* or *P. sordida*.

Methylation of PCP by fungi is thought to be a detoxification mechanism. Although PCA has been shown to be less toxic than PCP to both fungi and humans, it may represent a backward step in PCP metabolism. PCA may have to be demethylated before further oxidative metabolism. However, PCA may also be susceptible to the same catabolic pathway responsible for the degradation of PCP; its accumulation in the chip cultures may be an artifact of the experimental conditions.

The lignin-degrading system of *P. chrysosporium*, which is assumed to be involved in the initial steps in PCP metabolism, is expressed only under secondary metabolic conditions. These conditions are triggered by depletion of nitrogen, carbon, or sulfur in the growth medium. Since wood is nitrogen poor, the natural stimulus for secondary metabolism is probably nitrogen depletion. The chips in the first experiment were supplemented with 5000 ppm glutamine (959 ppm N) to stimulate rapid and extensive fungal growth. As the fungus colonized the glutamine supplemented chips, it would have encountered the PCP and the glutamine simultaneously. The level of nitrogen provided by the glutamine may have suppressed or severely inhibited the lignin-degrading system. Therefore, if *P. chrysosporium* encountered the PCP in the primary metabolic state, when the lignin-degrading system had not initiated oxidative degradation, avoiding the toxic effects of PCP, an alternative detoxification method, namely methylation, was in place.

To test the theory that the level of nitrogen in the glutamine supplemented chips suppressed the lignin-degrading system resulting in conversion of most of the PCP to PCA, a study was conducted in which the conversion of PCP to PCA and dry weight loss by *P. chrysosporium* was compared in chips supplemented with different sources of nitrogen and carbon. The different nutritional supplements and supplement levels are given in Table 2 with the final concentration of the supplements in mg/kg. Three inoculated and two noninoculated cultures were prepared for each treatment. Dry weight loss and concentrations of PCP and PCA in sterile softwood chips was determined after 3 weeks.

Dry Weight Loss

Dry weight loss of the chips due to fungal activity is the result of a combination of mineralization of all lignocellulosic materials (lignin, cellulose, and hemicellulose) and is therefore a general reflection of the growth and metabolic activity of the fungus. The greatest percentage of dry weight loss was obtained in chips supplemented with glutamine (Table 7). However, the weight loss obtained with supplemental glutamine was not significantly different than that obtained when glucose or NH_4Cl were used as supplements. Percentage dry weight loss was very low when KNO_3 or glycerin were used as supplements and when the chips were not supplemented.

These results indicated that (1) supplementing with a material that contains both carbon and nitrogen (e.g., glutamine) resulted in only slightly better dry weight loss than supplementing with material that contained either nitrogen (NH_4Cl) or carbon (glucose) alone, (2) significantly greater weight losses were obtained when the chips were supplemented with carbon or nitrogen versus no supplement, and (3) the greater weight losses obtained using glucose or NH_4Cl versus glycerin or KNO_3 demonstrate that the source of carbon or nitrogen was important in affecting weight loss.

PCP Depletion

The initial and final concentrations of PCP and PCA in chips receiving the different supplements are given in Table 1. The initial PCP concentration in the chips averaged 367 mg/kg, except in chips supplemented with glutamine. Chips supplemented with glutamine appeared to have a significantly higher PCP concentration (551 ppm). However, after 3 weeks the PCP concentration in noninoculated chips increased, in all cases, except in chips supplemented with glutamine. This suggests that (1) incubation for 3 weeks in a warm moist environment may have made it difficult to extract PCP due to a softening of the wood and that (2) pretreatment with glutamine had a beneficial effect on extraction of PCP. The initial PCA concentration in the chips was 4.5 mg/kg except in chips supplemented with glycerine. Extraction of these chips resulted in more than twice the amount of PCA found in chips receiving the other supplements.

Based on the supplements used in this study, the results demonstrate that supplementing the chips was important for dry weight loss but not for overall PCP removal by *P. chrysosporium*. The results also show that a positive correlation between dry weight loss and PCP removal depends on the supplement. Supplementing with glutamine or glucose gave both high percentage weight loss and high PCP decrease. However, supplementing with NH_4Cl gave a high percentage weight loss but a relatively smaller percentage PCP decrease. Supplementing with inorganic

nitrogen, especially KNO_3 , resulted in significantly less PCP removal and a greater percentage of the removal due to conversion to PCA. This supports the premise that a high concentration of nitrogen inhibited or delayed the lignin-degrading system and thus catabolism of PCP. The relatively higher percentage PCP decrease obtained with supplemental glutamine may have been due to greater fungal growth, as evidenced by greater weight loss obtained with glutamine and thus earlier depletion of nitrogen and expression of the lignin degrading system. Glycerin was a poor carbon source for growth and appeared to severely inhibit expression of the lignin-degrading system, as evidenced by the fact that virtually all of the PCP depletion was due to conversion of PCP to PCA.

Conclusions and Recommendations From Initial Studies

White-rot fungi effectively decreased the PCP concentration of PCP-contaminated hardwood and softwood chips.

The fungal species used varied greatly in their abilities to effect dry weight losses and decreases in the PCP concentration of the chips and in their metabolism of PCP in wood chips.

Nutrient supplementation was important for obtaining substantial dry weight losses but not for PCP decreases. However, greater dry weight losses generally were associated with greater percentage decreases of PCP, but this depended on the nutrient supplement. Since the primary concern is complete destruction of the PCP, optimization of the fungal treatment process should focus on PCP removal versus weight loss.

Chip sterilization was important to rapid dry weight loss and PCP depletion when the fungi did not compete well initially with the indigenous microbes in nonsterile chips. Dry weight loss in softwood chips inoculated with *P. chrysosporium* was increased more than 3-fold by sterilization. However, it appears that over time, the white-rot fungi were able to outcompete the indigenous organisms, colonize the chips and transform the PCP. Chip sterilization can be avoided by identifying fungi that can outcompete the indigenous microbes and rapidly and completely colonize the chips.

Based on these studies *T. hirsuta* was selected for additional investigation.

3 Determination of Optimal Growth Factors for *T. hirsuta*

Materials and Methods

PCP-Treated Materials

Nailed pine ammunition boxes constructed mostly of lodgepole (*Pinus contorta* Dougl. ex Loud.) or ponderosa pine (*Pinus ponderosa* Dougl. ex Loud.) panels and yellow poplar (*Liriodendron tulipifera* L.) end cleats, and wire-bound boxes, constructed of hardwood, most blackgum (*Nyssa sylvatica* Marsh.) and sweetgum (*Liquidambar styraciflua* L.) panels with yellow poplar end cleats, were used. Hardwood and softwood materials from the different types of ammunition boxes were chipped using a hammer mill to pass a 3.8 cm screen. The chipped materials were then sorted into three size classes using a mechanical sieve fitted with three screens that had either 2.54 cm, 1.26 cm, or 0.66 cm round openings. The size classes were: large, 1.26 cm to 2.54 cm; medium, 0.66 cm to 1.26 cm; and small, less than 0.66 cm.

*Fate of PCP in Chips Inoculated With *T. hirsuta**

The fate of PCP in sterile softwood chips inoculated with *T. hirsuta* or left non-inoculated as control, was evaluated. Inoculated and control cultures were prepared using chips spiked with ^{14}C [PCP]. Initial concentrations of PCP and PCA, a known fungal metabolite of PCP, were determined on chip samples that were not amended with ^{14}C [PCP] but that were taken from a common batch and treated identically to the chips used to prepare the cultures. After 4 weeks of incubation the amount of organic extractable ^{14}C was determined by measuring the amount of ^{14}C associated with two 1-ml aliquots from a hexane-acetone extract volume. Nonextractable ^{14}C (^{14}C associated with the organic extracted chips) was determined by burning two 0.1-g samples from each sample of previously extracted chips in a Harvey Model OX-600 Biological Oxidizer. Radioactivity from the evolved CO_2 was determined by liquid scintillation counting. The ^{14}C content of the fungus-infested malt agar pieces was determined by allowing the agar to air dry, followed by combustion and liquid scintillation counting as described for the chips.

Determination of Optimum Growth Temperature and Growth Rates

The optimum temperature for growth of *T. hirsuta* was determined by measuring the hyphal extension rate on 2 percent malt agar. Plates of 2 percent malt agar for determination of temperature growth optima were inoculated with 2-mm plugs taken from inoculum plates and incubated at 12, 16, 20, 22, 24, 28, 30, 32, 36, and 40 °C. Five plates were prepared for each temperature. The mycelial extension rate was recorded as the average daily increase in colony diameter (in millimeters) measured in two perpendicular directions.

Sensitivity of T. hirsuta to PCP

The sensitivity of *T. hirsuta* to PCP was determined by measuring the hyphal extension rate on 2 percent malt agar containing either 0, 5, 10, 15, 20 or 25 ppm PCP. Five plates were prepared for each concentration and inoculated as described previously. The plates were incubated at 36 °C.

Sensitivity of T. hirsuta to PCP Concentrations in Wood Supplemented Agar

The mycelial extension rates of *T. hirsuta* were determined on 2 percent malt agar, supplemented with clean aspen wood chips (0.7 g per plate), and PCP concentrations of 0 (control), 5, 10, 15, 20, 25 mg/L. Three plates per PCP level were prepared and inoculated as previously described. The plates were incubated at 36 °C for 10 days. Fungal growth was observed at all PCP concentrations, although there was a decrease in growth rate with increasing PCP concentration. The increased tolerance of *T. hirsuta* to PCP in the presence of the wood chips was probably due to the adsorption of PCP by the chips, which lowered the concentration of PCP in the agar.

Depletion of PCP in Chips by T. hirsuta

The effect of chip size on the ability of *T. hirsuta* to deplete PCP in a mixture of hardwood and softwood chips was investigated in 8-L bioreactors. The bioreactors were constructed using clear polycarbonate 8-L storage containers with removable lids (Figure 4). Inlet and outlet ports used for aeration of the chamber consisted of 1.27-cm barbed bulkhead fittings located on the lower side and lid, respectively. Inlet and outlet ports were protected from microbial contamination by 0.2 µm filters and sterile glass wool traps, respectively. A perforated platform constructed of Poly-P Perf sheet (0.24 cm by 0.79 cm) was supported 3.8 cm above the bottom of the container by three Poly-P rods (0.75-in. diameter).

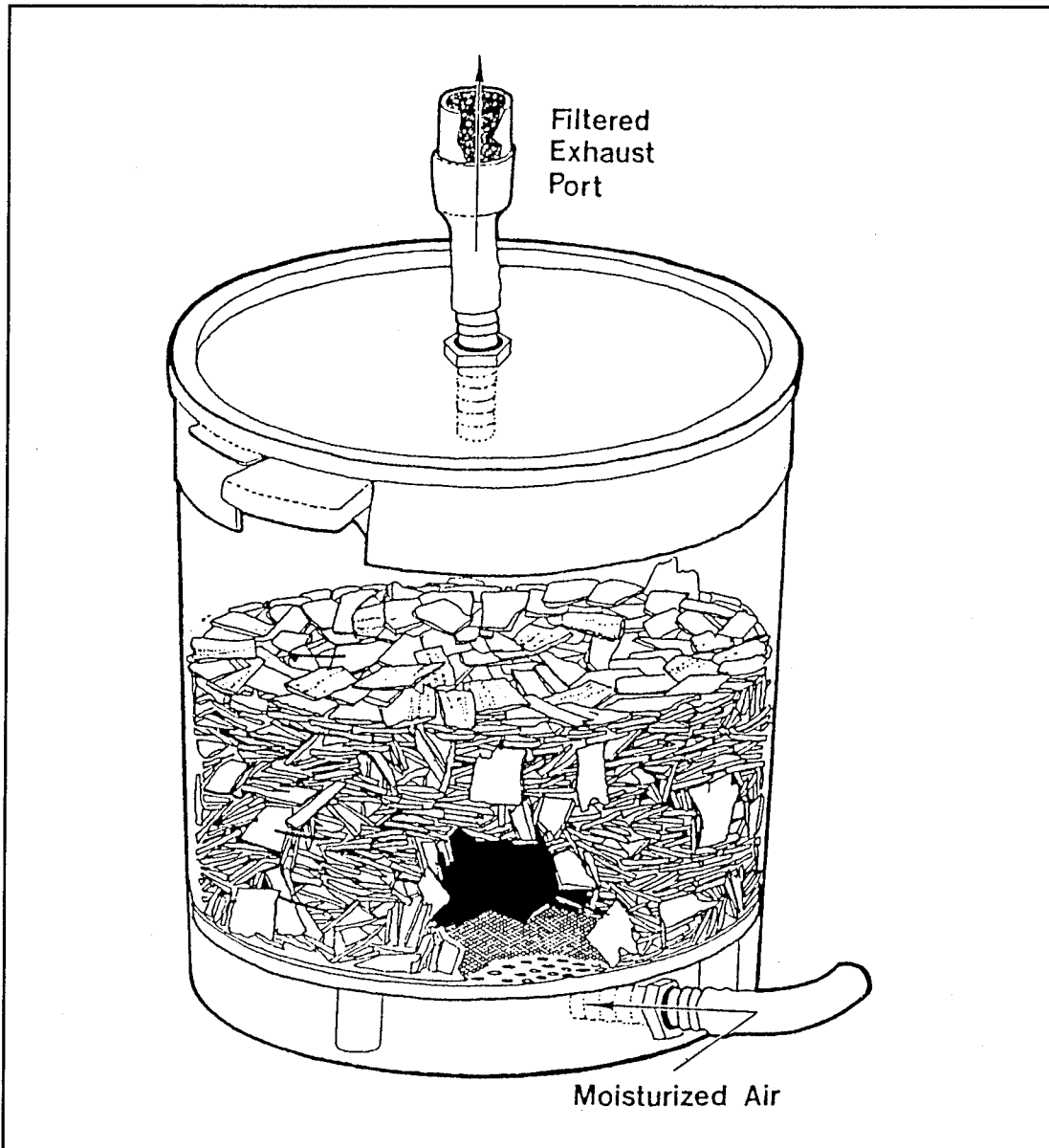

Figure 4. Schematic of 8L bioreactor.

Four bioreactors containing a combination of sterile hardwood and softwood materials were prepared for each chip size class. Three inoculated reactors and one control reactor were prepared for each chip size class. Humidified air was passed continuously through each of the bioreactors at a rate of 200 ml/min. Incubation temperature was 36 °C.

One bioreactor from each chip size class was harvested after 2, 4, and 6 weeks. Control cultures were harvested after 6 weeks. The chips in each bioreactor were divided into four harvest levels; each level represented approximately one-quarter of the chips in the reactor. The chips were harvested sequentially starting with the upper harvest level. The chips corresponding to a given level were removed and mixed

thoroughly. Three subsamples were then taken from the chips in each level. Duplicates of each subsample were then analyzed for PCP.

Effect of Chip Size, Harvest Level, and Inoculum Type

The effect of chip size, harvest level, and inoculum type on the depletion of PCP by *T. hirsuta* in a mixture of hardwood and softwood chips was investigated. The chips used in this experiment were taken from the control chips used in the bioreactor experiment; they received no further treatment before culture preparation. The three inoculum types were: inoculum plates (pieces of 2 percent malt agar supporting growth of *T. hirsuta*), mycelial inoculum from liquid cultures of *T. hirsuta* (mat), and a commercial spawn mix supporting growth of the fungus (spawn). Cultures were prepared by aseptically placing about 25 g of medium and/or large chips or about 21 g small chips (dry weight) in a 272 ml canning jar with a modified cover. Covers were modified to allow adequate air exchange by gluing a piece of microporous material over a 0.32-cm hole on the inside of the cover. Initial concentrations of PCP were determined on three samples from each chip size.

Three fungal cultures were prepared for each chip size and inoculum treatment by adding the amount of each inoculum type that gave 24 mg of fungal biomass to the chips. Fungal biomass was determined for the mycelial inoculum gravimetrically. The amounts of fungal biomass in the plate and spawn inocula were determined by measuring the amount of ergosterol present per gram of inoculum and estimating the amount of fungal biomass based on 5 µg ergosterol/mg fungal biomass (Davis and Lamar 1991).

Three control cultures consisting of noninoculated chips were prepared for each chip size. The chips were incubated at 36 °C. After 4 weeks, the chips in each jar were harvested by dividing the chips into three harvest levels (HL). Final PCP concentrations were determined from triplicate subsamples from each level.

Results and Discussion

Fate of PCP in Sterile Softwood Chips

Inoculation of sterile softwood chips with *T. hirsuta* yielded results as discussed on page 22.

The mass balance analysis of ¹⁴C[PCP] in softwood chips inoculated with *T. hirsuta* indicated that metabolism of PCP by this fungus resulted in either complete degradation (27 percent mineralization) or stabilization (42 percent nonextractable)

of most of the PCP. Another 23 percent of the ^{14}C was associated with the fungal-infested malt agar pieces used to inoculate the chips. Part of this may have been due to absorption of ^{14}C [PCP] from the chip surfaces by the agar. However, the cultures were prepared by adding the ^{14}C [PCP] to the chips, after which they were thoroughly mixed, autoclaved, then inoculated by placing pieces of malt agar infested with *T. hirsuta* on top of the chips. Thus, it is unlikely that the malt agar would have had access to 23 percent of the ^{14}C [PCP]. Most of the ^{14}C associated with the malt agar was probably associated with the fungal hyphae growing on the agar and would have eventually been mineralized had the experiment continued.

If all the ^{14}C in the organic extractable fraction was associated with PCP, the decrease in the PCP concentration would have been about 94 percent. This is greater than the 84 percent decrease determined from differences between concentrations of nonradioactive PCP in inoculated and noninoculated chips. However, the ^{14}C [PCP] presumably was primarily associated with the chip surfaces and therefore was more available than the nonradioactive PCP, which was deposited in cell walls and lumens. The 84 percent decrease of PCP in the mass balance experiment is also greater than the 60 percent decrease caused by *T. hirsuta* in Experiment 2. In Experiment 2, the cultures were grown using a passive diffusion system to maintain adequate aeration. In the mass balance study, the cultures were aerated using forced aeration every 3 or 4 days. Thus, the greater percentage decrease obtained in the mass balance study was probably due to greater aeration resulting in more rapid and extensive oxidation of the PCP.

Growth Rate and Sensitivity of *T. hirsuta* to PCP

The optimum temperature for growth of *T. hirsuta* was 36 °C. Growth was completely inhibited at 6 °C and 44 °C (Figure 5). When the fungus incubated at these temperatures was transferred to 36 °C, growth was observed indicating that incubation at these temperatures did not kill the fungus.

Sensitivity studies demonstrated that the highest PCP concentration that *T. hirsuta* would tolerate on 2 percent malt agar was 5 ppm with complete inhibition at greater concentrations. Inoculum plugs that were used to inoculate plates containing more than 5 ppm PCP were transferred to plates containing 0 ppm PCP. These plates were incubated at 36 °C. Fungi previously grown at levels higher than 15 ppm showed no observable growth. These studies demonstrated that *T. hirsuta* has a very low tolerance to PCP.

When aspen wood chips were added to the malt agar along with the PCP, *T. hirsuta* was able to grow at levels as high as 25 ppm (Figure 6). This was probably due to

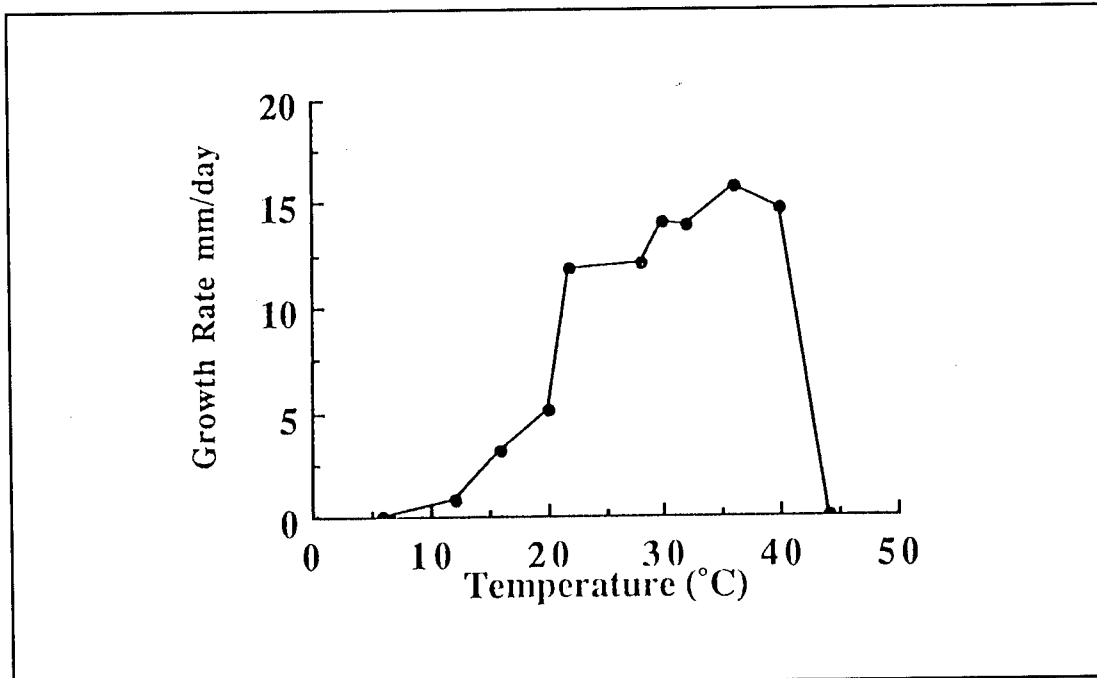

Figure 5. Effect of temperature on the growth rate of *T. hirsuta* on 2 percent malt agar.

adsorption of PCP by the wood chips. This adsorption effectively lowered the concentration of PCP in the agar to levels that allowed fungal growth.

Depletion of PCP in a Mixture of Hardwood and Softwood Chips

Inoculation of a mixture of hardwood and softwood chips of various sizes with *T. hirsuta* generally resulted in decreases in the concentration of PCP in the chips after 6 weeks compared to noninoculated controls. The magnitude of the decreases varied

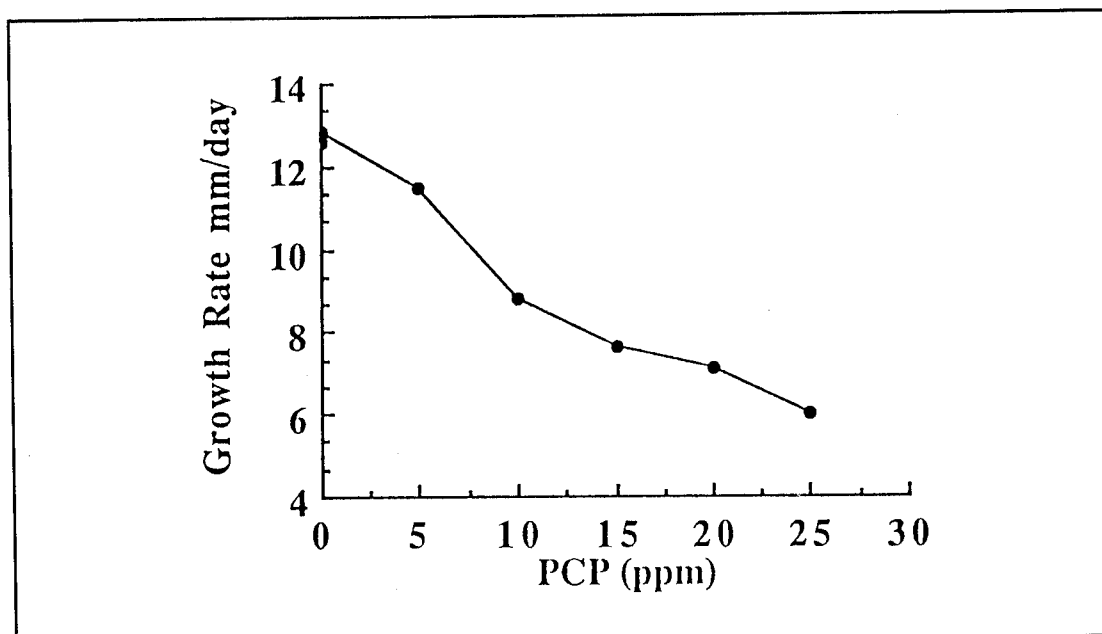

Figure 6. Effect of PCP on the growth rate of *T. hirsuta* when aspen wood chips were included in the 2 percent malt agar.

greatly with chip size and with harvest level. The extent of PCP depletion was not as great as that observed in the previously described materials balance study (84 percent). The lower levels of depletion were probably a result of (1) inadequate aeration throughout the bioreactor and (2) an insufficient ratio of fungal inoculum to chip mass, both of which might have contributed to less than optimum fungal growth and activity.

The concentration of PCP in the control chips increased over time (Figure 7). This increase, observed previously (see Table 4), was attributed to physical and/or chemical changes to the chips that occur during incubation, making the PCP easier to extract. The magnitude of the increase was significantly affected by chip size but not by harvest level. There was a significantly greater ($p > 0.0001$) increase (105.5 percent) in PCP concentration in the large chips than in the medium (22 percent) or small (46 percent) chips (Figure 7). This suggests that aeration, which was less limiting in the reactors containing the large and medium chips because of larger air channels around these chips, might have played a role in the physical/chemical changes that increased the extractability of PCP. Chips from the large size class had the highest final concentration of PCP (444 ppm), which is probably close to the "real" level of PCP in the chips.

After 6 weeks the concentration of PCP in inoculated chips was significantly affected by both chip size and harvest level (Table 9). Over all harvest levels, the concentration of PCP was significantly lower ($p < 0.0001$) in the medium and large chips than in the small chips. Over all chip sizes, the concentration of PCP was significantly less ($p < 0.0001$) in the top harvest level chips than in the chips from the three lower harvest levels.

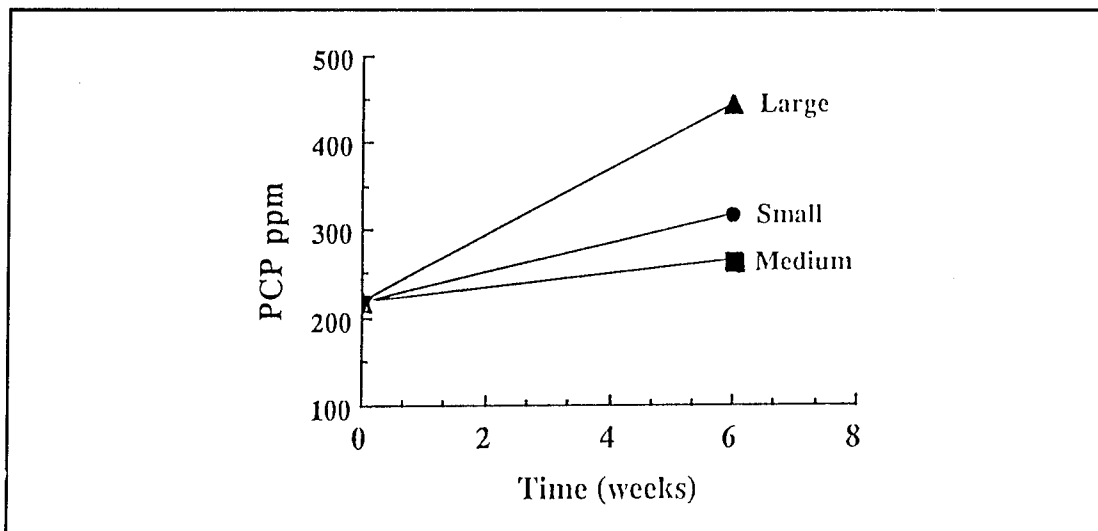

Figure 7. Initial and final concentrations of PCP in large, medium, and small control chips.

Table 9. Effect of chip size and harvest level on the concentration of PCP in chips inoculated with *T. hirsuta* after 6 weeks.

Size	Harvest Levels				Totals
	HL1	HL2	HL3	HL4	
Small	103.7 ^a	313.6 ^b	450.8 ^c	266.6 ^b	283.6
Medium	99.9 ^a	188.0 ^b	210.5 ^b	199.0 ^b	181.1
Large	114.0 ^a	231.9 ^b	171.0 ^{ab}	169.2 ^{ab}	171.7
Totals	106.6 ^a	244.5 ^{bc}	277.4 ^c	2169 ^b	

^a Means within rows followed by the same letter are not significantly different. Means were separated using Fisher's PLSD procedure, $\alpha = 0.05$.

There was a significant interaction ($p = 0.0036$) between chip size and harvest level at 6 weeks. Therefore, the data for each individual chip size were analyzed separately to determine the effect of harvest level on the final PCP concentration. Regardless of chip size, the concentration of PCP was least in the top harvest level chips (Table 9). The highest PCP concentrations were found in small chips from the three lower harvest levels. PCP concentrations in chips from these levels varied between 2.5 to 3 times greater at the lowest harvest level (HL4) and the second harvest level (HL2) to about 4.5 times greater at the third harvest level (HL3). Concentrations of PCP in large and medium chips from the lower three harvest levels were about 2 times greater or less than those found in HL1 chips.

Concentrations of PCP in inoculated chips over the course of the study in small, medium, and large chips for the four harvest levels are shown in Figure 8. As was observed in control chips, there were increases in the PCP concentration in inoculated chips of all sizes, except in those chips from HL1. Unlike increases in control chips, those in inoculated chips were always followed by decreases in the PCP concentration, except in small chips at HL3 (Figure 8C). Therefore, the decreases in PCP concentrations were due to the activity of *T. hirsuta*. The differences in PCP concentrations observed among the different sized chips, at the different harvest levels, were due directly or indirectly to the effects of chip size and harvest level on fungal growth and activity.

The bioreactors were inoculated by placing pieces of fungal-infested malt agar on the top layer of HL1 chips. Therefore, the fungus colonized the chips in the reactors in sequence from HL1 down to HL4. Chip size, or more precisely, the size of the air spaces around the chips appeared to greatly influence the efficiency of aeration and thus fungal growth and activity, at the different harvest levels. The efficiency of aeration throughout the large chips, which were surrounded by fairly large spaces, was probably much greater than that throughout the small chips because the amount of moisture (60 percent) and the size of the small chips caused them to become packed

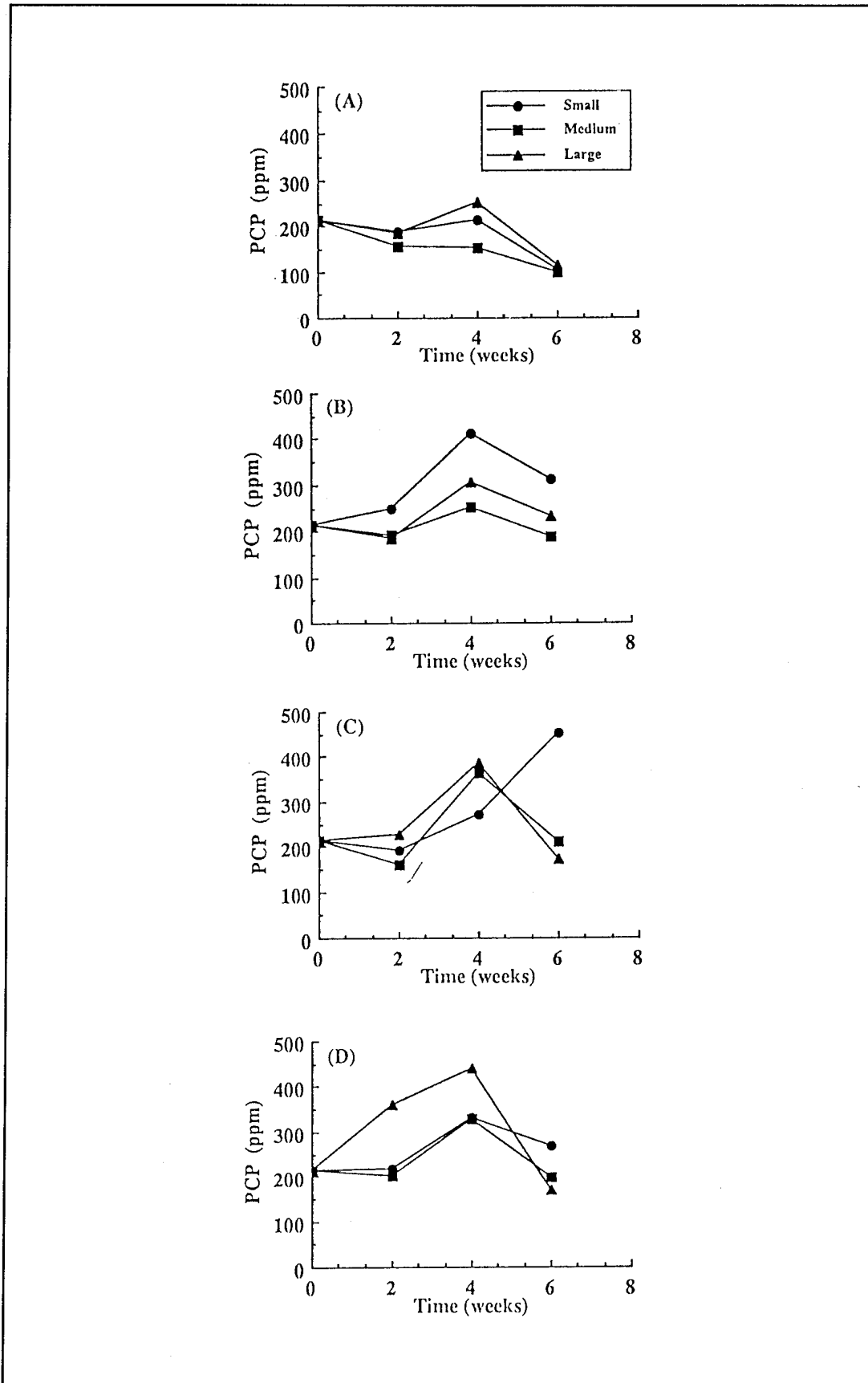

Figure 8. Effect of chip size on the concentration of PCP in inoculated chips in HL1 (A), HL2 (B), HL3 (C), and HL4 (D).

very tightly. The reactors were aerated from the bottom and the headspaces of the reactors were open to the outside atmosphere through the outlet ports. Therefore, if aeration was limited by chip size, growth and activity in HL2 and HL3 were more likely to suffer from inadequate aeration than that in HL1 and HL4 because of the proximity of the chips in the latter harvest levels to air sources.

Another factor contributing to the differences in PCP concentrations among the various chip sizes and harvest levels was the availability of the PCP to the fungus. During application, the PCP is deposited in the wood cell walls and cell lumens (Figure 9). PCP deposited in the lumens is readily available to the fungus because it can be accessed by the fungus without cell wall degradation. However, the bulk of the PCP is deposited in the wood cell walls and only becomes available as the cell wall is degraded. It has been postulated that none of the enzymes currently identified as being involved in lignin and cellulose (and also PCP) degradation initiate the process of decay except at the lumen surface (Evans et al. 1991). Evidence for this hypothesis is supported by data that demonstrate cell wall decay before the presence of the enzymes. Initiation of decay is thought to be caused by small molecular weight molecules that are released before ligninases or cellulases and that can readily diffuse away from the fungal hyphae and penetrate the pores of the lignocellulosic matrix (i.e., the cell wall). The degradative activity of the small molecular weight molecules might result in release of PCP from the wood cell walls. The PCP would only be transformed upon release of the extracellular ligninases or after absorption by the fungal hyphae. Thus, the rate and extent of fungal colonization will greatly affect the availability of PCP to the fungus.

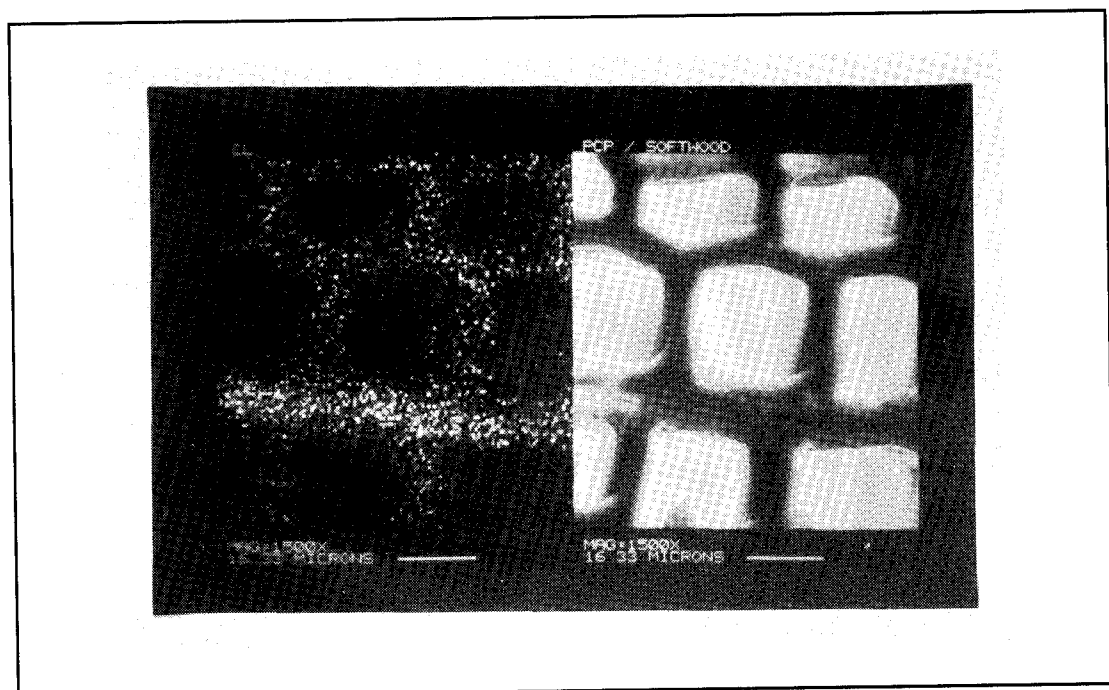

Figure 9. Scanning electron micrograph of PCP-treated softwood.

Taking the factors discussed above into consideration, the data in Figure 8 can be interpreted as follows. In HL1 chips, fungal colonization was rapid and extensive because of the proximity of the chips to the inoculum and because aeration was not severely limiting. Initiation of decay by small molecular weight molecules, which resulted in increases in the availability of PCP, was followed immediately by expression of the lignin-degrading system, the activity of which results in PCP depletion. Thus, as the PCP in the cell walls of HL1 chips became available it was quickly transformed and generally no increase in the PCP concentration was observed (Figure 8A). In HL1 through HL3 fungal rates and extents of colonization of the chips were lower than in HL1 chips because of the decreased proximity of the chips to the inoculum and possibly because of inadequate aeration in HL2 and HL3. As a result of the lower rates and extents of fungal colonization there was a lag between initiation of decay, which resulted in release of PCP and expression of the lignin-degrading system. Thus, there was an increase in the PCP concentration in the chips in HL2 through HL4 that peaked at 4 weeks. The increase was followed by a decrease in the PCP concentration at 6 weeks (Figures 8B through 8D). In the small chips in HL3 where distance from the inoculum and inadequate aeration might have been the most unfavorable to fungal colonization, the peaking of PCP concentration was delayed from 4 weeks to 6 weeks (Figure 8C).

Growth of *T. hirsuta* in the bioreactors was clearly inferior to that obtained in flask experiments. The primary reason for this was probably inadequate aeration throughout the chip mass in the bioreactors.

Effect of Chip Size, Harvest Level, and Inoculum Type

There were no significant differences ($p = 0.5138$) in initial PCP concentrations among the chip sizes (Table 10). The mean concentration (350.8 ppm) compares well with the overall final concentration (338.2 ppm) of control chips from the bioreactor experiment. As was observed previously, there was a significant overall increase in the PCP concentration in control chips after incubation. The increase was due to changes in the concentration of PCP in small and medium but not large chips (Table 10). The final PCP concentration in control chips was not affected by harvest level ($p = 0.4718$).

Overall (including data from control chips), the final concentration of PCP was significantly affected by inoculum type. The majority of the variation between the inoculum type means (93.38 percent) was due to the significant difference between the concentration in control chips versus that in inoculated chips. This indicates that there was a significant depletion of PCP in inoculated chips caused by *T. hirsuta*. Thus, the effects of inoculum type, chip size, and harvest level on the concentration of

Table 10. Initial PCP concentrations in small, medium, and large chips and PCP concentrations in small, medium, and large control chips at the three harvest levels after 4 weeks.

Chip Size	Harvest Level				
		HL1	HL2	HL3	Mean
	Initial	After 4 weeks			
	PCP ppm				
Small	347.0	500.9	550.3	398.8	483.3
Medium	307.1	502.5	556.2	435.8	498.2
Large	398.4	414.6	326.7	396.3	379.2
Mean	350.8	472.7	477.7	410.3	453.6

PCP in inoculated chips only were determined by analyzing the data with the data for control chips removed (Table 11).

The concentration of PCP in inoculated chips was significantly affected by inoculum type and harvest level but not by chip size. The concentration of PCP in chips inoculated with either the mat or spawn inoculum was significantly less than that in chips inoculated with the plate inoculum (Table 11). The rationale for investigating the effect of chip size was that the surface area and thus the availability of PCP to the fungus is increased with decreasing chip size.

In the bioreactor experiment, chip size significantly affected the concentration of PCP in inoculated chips. However, this effect may have been primarily due to the influence of chip size on aeration, as discussed earlier. This experiment was performed in small containers to allow adequate aeration. Chip size did not influence the PCP concentration in inoculated chips and thus the removal of PCP by the fungus. This indicates that if aeration is not limiting, there is no advantage to using small versus large chips.

Table 11. Effect of inoculum type, chip size, and harvest level on the concentration of PCP in inoculated chips after 4 weeks.

Inoculum Type	ppm	Chip Size	ppm	Harvest Level	ppm
Plate	277.9 ^a	Large	226.7 ^a	HL1	192.2 ^a
Mat	220.7 ^b	Medium	249.5 ^a	HL2	233.8 ^{ab}
Spawn	208.0 ^b	Small	229.7 ^a	HL3	279.6 ^b

^a Means with columns followed by the same letter are not significantly different. Differences among means were detected using Fisher's PLSD procedure ($\alpha = 0.05$).

In general, depletion of PCP was greater in chips located at the top of the jar than those located at the bottom (Table 11). This pattern was consistent with the results from the chips inoculated with the plate or the spawn inoculum but not with those of the mat inoculum (Figure 10).

Inoculation of chips with the plate and spawn inoculum was accomplished by placing the solid pieces of inoculum on the upper layer of HL1 chips. As was observed in the bioreactors, relative proximity of the chips to the inoculum might have influenced the amount of PCP depletion in chips receiving plate or spawn inoculum, resulting in less PCP depletion at the lower chip levels (Figure 10). The mat inoculum consisted of a mycelial slurry. When the slurry was applied to the upper chip surface, it leached down through all the chip layers, effectively inoculating the entire volume of chips in the jar. PCP removal by *T. hirsuta* applied via the mycelial inoculum resulted in more consistent amounts of depletion throughout the entire chip volume (Figure 10).

Conclusions

Trametes hirsuta is a wood-degrading fungus that has a high sensitivity to PCP and a relatively high temperature for optimum growth (i.e., 36 °C). The high temperature optimum is not a liability because treatment of large amounts of chips will probably generate temperatures in excess of 36 °C. Temperature either in reactors or piles can be manipulated using aeration. Despite its high sensitivity to PCP, this organism caused an 84 percent depletion of PCP in 4 weeks. The depletion was a result of either complete breakdown of about 27 percent of the PCP (i.e., mineralization) or

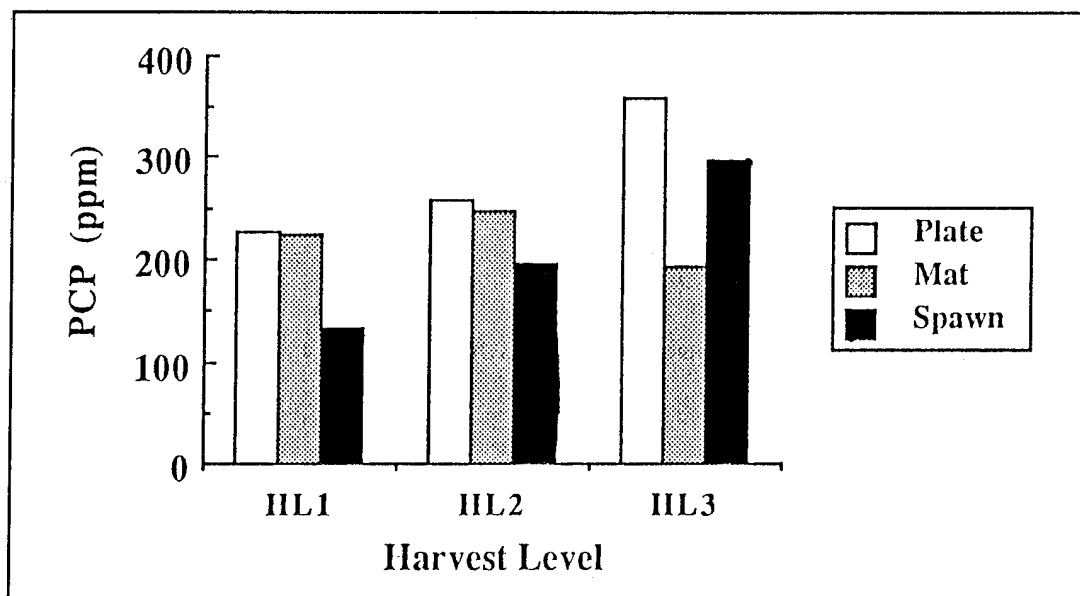

Figure 10. Effect of inoculum type on the concentration of PCP in inoculated chips at the various harvest levels.

transformation of about 66 percent of the PCP to innocuous products. Only 6 percent remained unchanged. These results indicate that this fungus has the potential to be an effective biological agent in a treatment method for the disposal of PCP-treated wood. Results from the bioreactor experiments demonstrated that adequate aeration, inoculum type, and placement of the inoculum are key factors to consider in further design of the method. These factors are critical to obtaining adequate fungal growth. Further studies were needed to optimize

- delivery of adequate aeration throughout the chip volume,
- the ratio of inoculum to chips that ensures copious fungal growth, and
- the optimum placement of the inoculum.

Also, the extraction procedure required improvement so results from initial extractions reflect the actual PCP concentration.

4 Improvement of PCP Wood Extraction Procedure

Initially, PCP was extracted from treated wood samples using a procedure developed to extract PCP from soil (Lamar, Larsen, and Kirk 1990). However, this procedure was ineffective for extracting PCP from treated wood. Therefore, a series of modifications to this procedure were tested to increase PCP recovery.

Soil Extraction Procedure Modified for Wood Samples

The soil PCP extraction procedure was applied to wood samples. The wood samples were air dried and then ground in a coffee grinder. Wood samples (2 g) were placed in culture tubes (25 by 150 mm) with teflon-lined screw caps. Approximately 50 to 100 g of sodium dithionite was then added to each tube before extraction. The wood samples were extracted twice for 1 hour on a rotating tumbler-shaker with 20 ml of hexane (1:1 acetone and hexane acidified to pH 2 with concentrated H_2SO_4). The combined extracts were then dried by passing them through a column of anhydrous Na_2SO_4 . Drying columns (18 by 240 mm) were prepared by placing a plug of silane-treated glass wool (Supelco) in the bottom of the drying tube and then adding 10 to 15 cm of anhydrous Na_2SO_4 . The column was then washed with 5 ml of hexane before the samples were passed through the column. Each sample was then loaded into the column and the extracts collected in clean culture tubes. After elution of the sample, the column was rinsed with 5 ml of hexane to ensure collection of the entire sample. The combined extract and rinse for each sample were heated to 60 °C and evaporated to less than 5 ml under a gentle stream of nitrogen. The final volume of each extract was then adjusted to 10 ml with hexane in volumetric flasks. The samples were stored at -20 °C until analysis by gas chromatography. The procedure, as described above, will be referred to as the "original procedure."

Effect of an Alkaline Extraction Procedure on PCP Recoveries From Wood

Because PCP solubility increases with increasing pH and the original extraction system used an acidified (pH 2) solution, the initial experiment examined whether

extraction efficiency could be increased by using an alkaline extraction solution. The original procedure was used except for the following changes:

- 0.5 N sodium hydroxide solution was substituted for Hexace,
- following the shaking step, the sodium hydroxide was acidified to pH 2 to reduce the Na-pentachlorophenate to the phenol form, and
- the acidified solution was then extracted with an equal volume of hexane.

Ten wood samples were processed using the original procedure and the average amount of PCP extracted was compared to that obtained from ten samples processed using the modifications (protocol 2). There was a 35 percent decrease in the amount of PCP recovered from the wood samples using the alkaline extraction solvent (Figure 11). Based on these results the use of an alkaline extraction solvent was abandoned.

Effect of Chip Size and Physical Extraction Method

The effect of chip size on PCP extractability was evaluated. PCP-treated wood chips were ground to various particle sizes, using a Wiley mill with an assortment of screens (10, 20, 30, 40, and 60 mesh). Wood chips ground in a coffee grinder, as called for in the original procedure, were also evaluated. Extraction by sonication compared to extraction using the tumbler-shaker (control) was also evaluated. The original procedure was used for the PCP extraction.

Particles milled through a 30 mesh screen had the highest PCP recovery and the tumbler-shaker method gave significantly greater recoveries (29 percent on average) than sonication. Based on these results all further extractions were performed using the tumbler-shaker on chips ground through a 30 mesh screen (Figure 12).

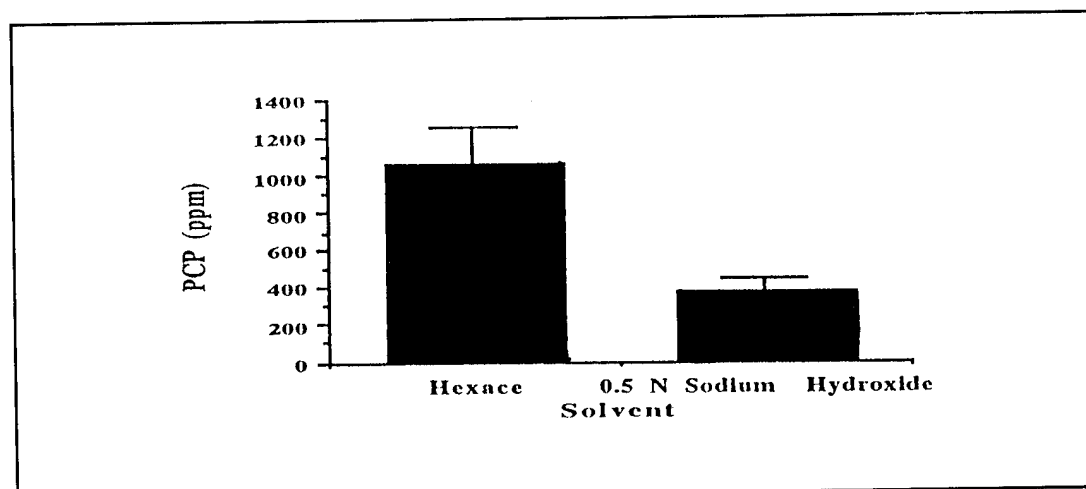

Figure 11. Comparison of 0.5 N Sodium Hydroxide to Hexace solvent for extraction of PCP from wood.

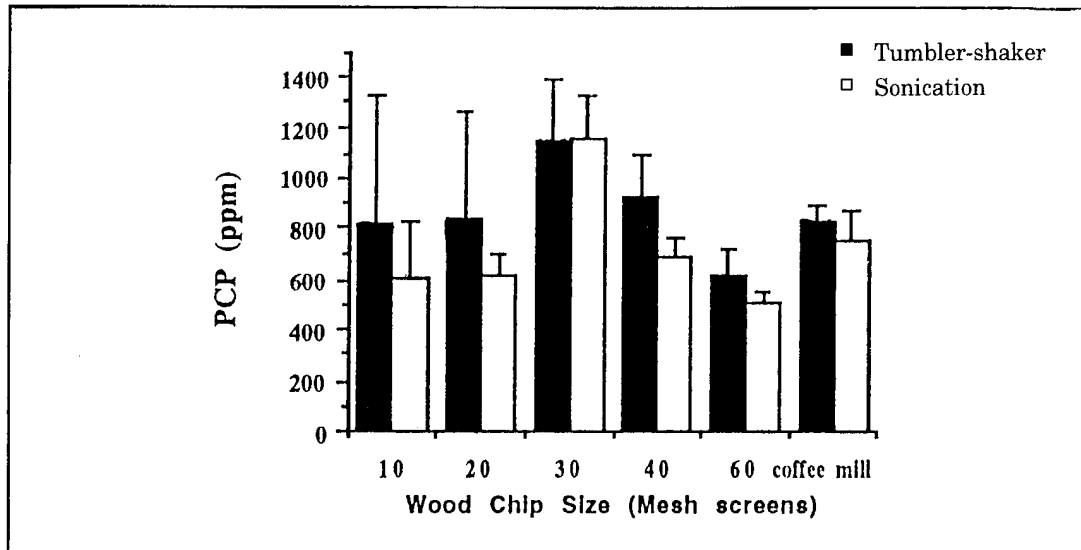

Figure 12. Effect of varying sizes of wood chips and sonication versus tumbler-shaker rotation on the extractability of PCP from wood.

Evaluation of Soxhlet Extraction

Soxhlet extraction, which allows for continuous extraction using the principle of repeated evaporation and condensation of the extracting solvent, was evaluated for recovery of PCP from treated wood. A solvent system consisting first of hexane for 48 hours followed by methanol for 48 hours, was used to extract PCP from 30 mesh wood chips. Both phases were analyzed for concentrations of PCP. The results showed that hexane PCP recovery (140 $\mu\text{g/g}$ of wood) was slightly lower than that from methanol (160 $\mu\text{g/g}$ wood) with the total recovery from both systems at 300 $\mu\text{g/g}$ of wood. This amount is far lower than that of the original extraction procedure which was 1150 $\mu\text{g/g}$.

Evaluation of Different Extraction Solvents

Methanol, hexane, acetone, and hexace were compared using the original extraction procedure. Acetone gave a significantly greater PCP recovery than the other solvents (Figure 13). Compared to the hexace, extraction with acetone gave 2.4 times greater PCP recovery. Based on these results, Hexace was replaced by acetone as the extraction solvent.

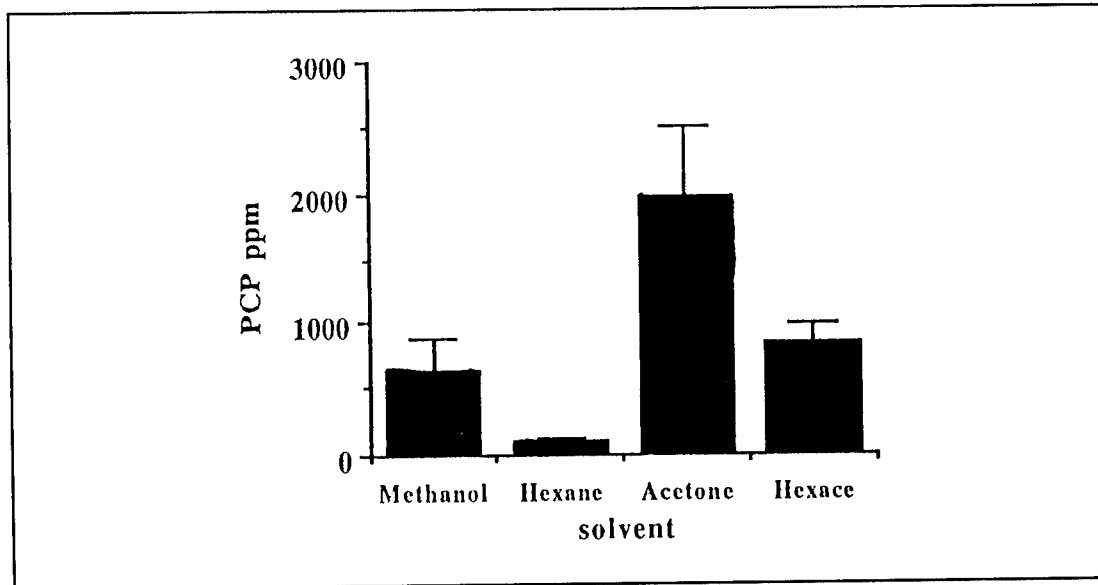

Figure 13. Effect of methanol, hexane, acetone, and hexace on the extractability of PCP from wood.

Effect of Increasing the Number of Extractions

Ten samples of PCP-treated ground wood chips were extracted for 1 hour, eight times with 20 ml acetone. After the third extraction, 95 percent of the extractable PCP was removed (Figure 14). It was felt that 95 percent recovery was acceptable. Therefore, the extraction protocol was amended to include three 1-hour extractions instead of two.

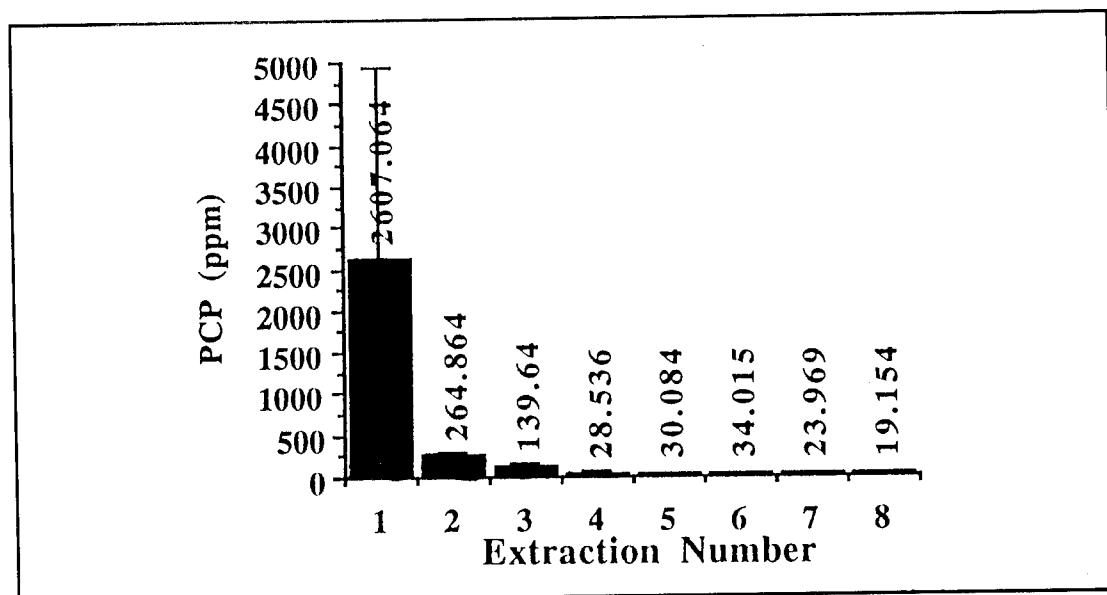

Figure 14. Effect of increasing the number of extractions on the recovery of PCP from wood.

New Protocol for Extraction of PCP From Wood

The new PCP extraction procedure for wood samples contains the following steps. Wood samples are air dried and then ground in a Wiley mill to 30 mesh size. Ground wood samples (2 g) are placed in culture tubes (25 by 150 mm) with teflon-lined screw caps. Approximately 50 to 100 g of sodium dithionite is then added to each tube before extraction. The wood samples are extracted three times for 1 hour with 20 ml of acetone on a rotating tumbler-shaker. The combined extracts are then dried by passing them through a column of anhydrous Na_2SO_4 . Drying columns (18 by 240 mm) are prepared by placing a plug of silane-treated glass wool in the bottom of the drying tube and then adding 10 to 15 cm of anhydrous Na_2SO_4 . The column is then washed with 5 ml of acetone before the samples are passed through the column. Each sample is then loaded into the column and the extracts collected in clean culture tubes. After elution of the sample, the column is rinsed with 5 ml of acetone to ensure collection of the entire sample. The combined extract and rinse for each sample are heated to about 60 °C and evaporated to less than 5 ml under a gentle stream of nitrogen. The final volume of each extract is then adjusted to 10 ml with hexane in volumetric flasks. The samples are stored at -20 °C until analysis by gas chromatography. This procedure will be referred to as the "new procedure."

5 Liquid Culture Experiments

All previous experiments focused on depletion of PCP-treated wood through solid phase treatment. The following experiments addressed the feasibility of fungal degradation of PCP in a liquid culture medium.

Determination of Optimal Medium for Growth

Four different media were evaluated for optimal growth for *T. hirsuta*: 1.5 percent malt extract (1.5 g malt extract per 100 ml H₂O), YMPG medium (3 g glucose, 3 g malt extract, 0.6 g Bacto peptone, 0.6 g yeast extract, 0.3 g Asparagine, 0.6 g KH₂PO₄, 0.1 mg thiamine, 300 ml H₂O), glucose-peptone broth (9 g glucose, 3 g peptone, 0.45 g KH₂PO₄, 0.15 g MgSO₄ • 7H₂O, 4.8 mg CuSO₄, 0.6 mg Thamine-HCl, 300 ml H₂O), and B_{III} (Brown, Glenn, and Gold 1990; Kirk et al., 1978). Shaking versus stationary incubation was also examined. For each medium, 20 flasks were prepared with 20 ml of medium; ten flasks for stationary and ten flasks for shaking incubation at 180 rpm. The cultures were inoculated with 2 mm agar plugs from inoculum plates and incubated at 36 °C . After 10 days, the mycelial mats were harvested by vacuum filtration and dried in a convection oven. For both the stationary and shaking cultures, the YMPG broth produced the largest mycelial weights (Figure 15). In addition, the shaking incubation produced the largest mycelial weight.

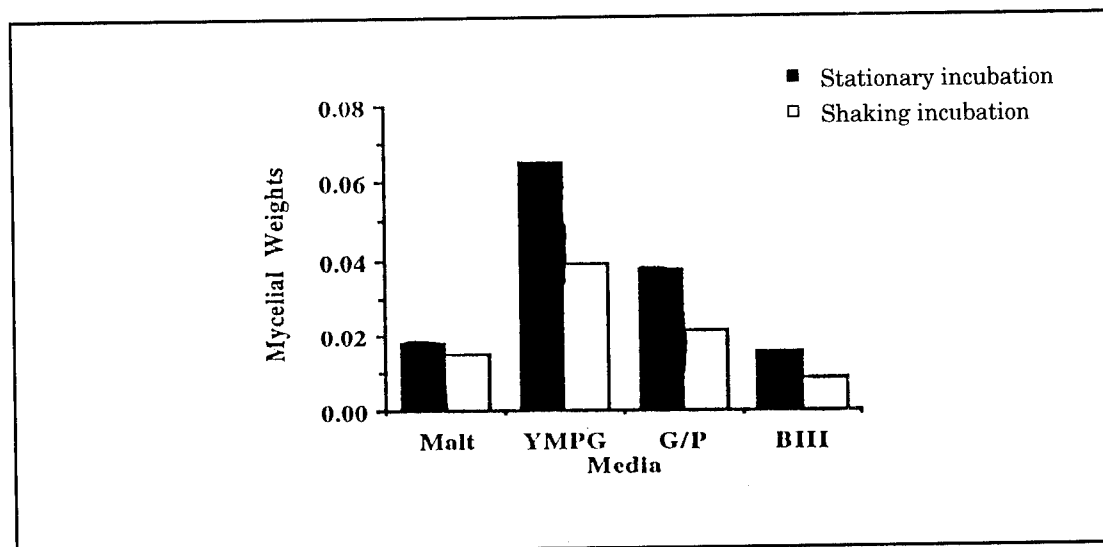

Figure 15. Effect of 1.5% malt extract, YMPG, G/P and B_{III} compared to shaking versus stationary incubation on the mycelial weights of *T. hirsuta*.

Effect of PCP-Treated Wood on *T. hirsuta* in Liquid Culture

The effect of incubating *T. hirsuta* in the presence of PCP-treated wood in YMPG broth was determined. PCP-treated wood was ground through a Wiley mill with a 30 mesh screen. The ground wood was then sterilized with methyl bromide and placed in 125 ml flasks with 20 ml of YMPG broth. The flasks were then inoculated with a 2 mm agar plug from 2 percent malt agar inoculum plates. The following wood amounts were tested: 0 (control), 1, 2, 3, and 5 g of ground wood. The effect on mycelial growth of shaking (180 rpm) versus stationary incubation was again evaluated. The cultures were aerated once a day with oxygen for 1 minute. After 16 days the experiment was concluded.

Growth was observed in all control cultures (stationary and shaking). However, there was no detectable growth in any cultures containing wood for both shaking and stationary incubation. Growth of the fungus was probably prevented by leaching of PCP from the chips into the culture medium. This is not surprising given the extreme sensitivity of *T. hirsuta* to PCP.

Effect of Preincubation of *T. hirsuta* in Liquid Culture

Because *T. hirsuta* was unable to grow from inoculum plugs in the presence of ground PCP-treated wood, the effect of allowing the fungus to develop mature hyphae before adding ground PCP-treated wood was evaluated. The experimental design of the previous study was repeated except for two changes: (1) the fungus was preincubated in YMPG for 5 days before adding the PCP-treated wood and (2) the range of ground wood added was limited to 0 (control), 0.1, 0.25, 0.5, 0.75, 1, and 2 g. Initial wood samples were analyzed using the acetone extraction method. After adding the PCP-treated wood, the cultures were incubated stationary at 36 °C for 2 weeks. The experiment was then disassembled and the wood was extracted for PCP (new procedure) and the mycelial mats were oven dried. There was a slight decrease in mycelial weights with increasing wood amounts except for the 0.5 g level (Figure 16). The results of the PCP extractions of wood revealed a significant decrease in PCP only at the 0.25 g wood level compared to the control cultures.

The results of these liquid culture experiments indicate that due to its sensitivity to PCP, the use of *T. hirsuta* in the depletion of PCP from PCP-treated wood in aqueous culture is not an effective approach.

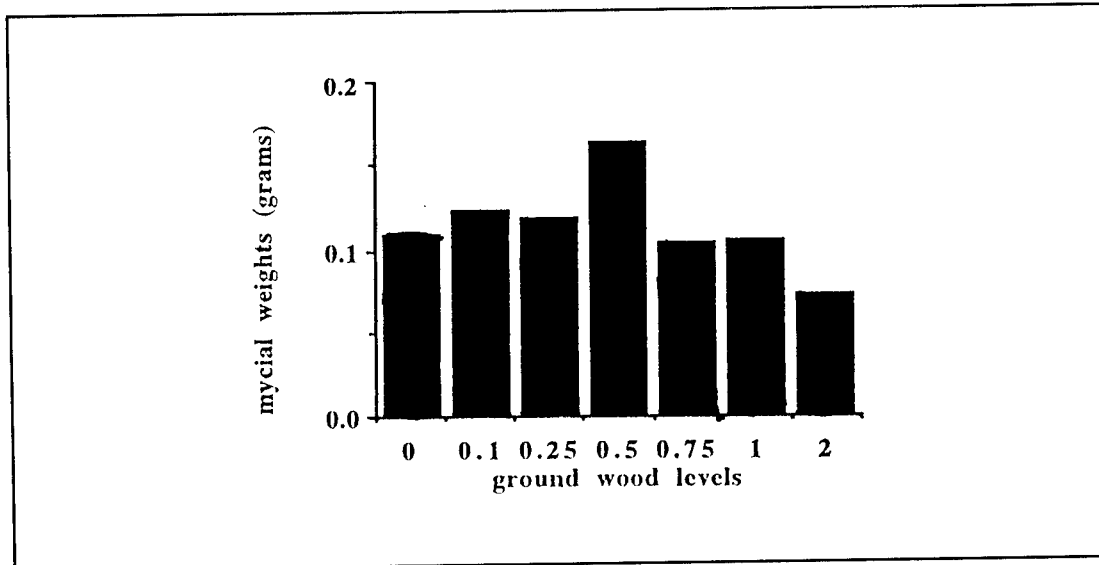

Figure 16. Effect of varying levels of PCP-treated ground wood with stationary incubation on the mycelial weights of *T. hirsuta*.

6 Bioreactor Experiments

The purpose of these experiments was to identify large-scale approaches to fungal depletion of PCP in wood from PCP-treated ammunition boxes. The experiments consisted of constructing bioreactors to determine the relative importance of manipulating environmental variables (i.e., aeration, temperature, and moisture) for optimization of the growth of *T. hirsuta*.

Materials and Methods

Fungus and Inoculum Preparation

Trametes hirsuta was grown on 2 percent malt agar slants at 36 °C for 1 week and then stored at 4 °C. The inoculum consisted of a nutrient fortified, grain-sawdust mixture. One-quart canning jars were filled with the mixture, covered with aluminum foil, and sterilized by autoclaving at 121 °C for 1 hour on 3 consecutive days. The moisture content of the mixture was then adjusted to 60 percent by adding sterile deionized water. The sterile mixture in each of the jars was inoculated by exposing it to pieces of malt agar from *T. hirsuta* slants and was incubated at 36 °C for 1 to 2 weeks.

Chemicals

Pentachlorophenol (purity, greater than 99 percent); 2,4,6-tribromophenol (purity, 99 percent); $\text{Na}_2\text{S}_2\text{O}_4$, technical grade (purity, about 85 percent); and Na_2SO_4 , anhydrous (purity, 99 percent), were used. Hexane, acetone, high-purity solvents and silane-treated glass wool were also used.

Depletion of PCP in Chips

The effect of inoculation rate on depletion of PCP in wood chips was examined in 8-L bioreactors. The bioreactors were constructed using clear polycarbonate 8-L storage containers with removable lids. Inlet and outlet ports used for aeration of the chamber consisted of two 1.27-cm barbed bulkhead fittings located on the side of the reactor (1.5 cm from bottom) and the lid (Figure 17). Two 0.6-cm barbed bulkhead fittings

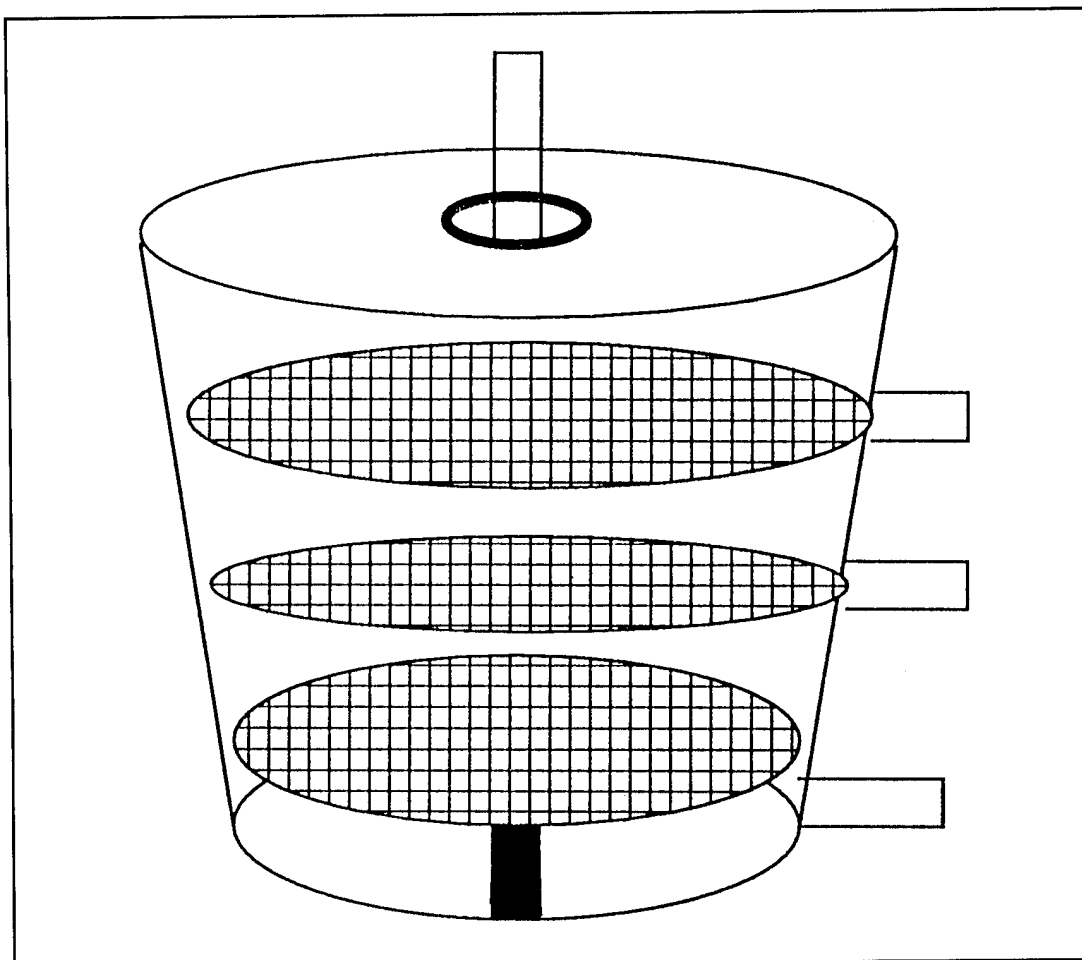

Figure 17. 8-Liter bioreactor.

were located on the side of the reactor 11.5 and 17 cm, respectively, from the bottom. Three perforated platforms were constructed of Poly-P Perf sheet (19 cm diameter by 0.5 cm thickness). The lower platform was supported 3.8 cm above the bottom of the container by three Poly-P rods and the remaining two platforms rested on chips when the reactor was loaded, a distance of 11.5 and 17 cm, respectively, from the bottom. These two platforms had fastened plastic tubing (diameter, 0.6 cm) coiled tightly to the top of the Poly-P material. The plastic tubing contained perforations to allow even distribution of air, which was delivered bidirectionally from two locations in the coils.

Three bioreactors containing a combination of hardwood and softwood chips 1.27 to 1.90 cm long from PCP-treated ammunition boxes were adjusted to 60 percent moisture with deionized water. Two reactors were inoculated with *T. hirsuta* inoculum at a rate of 20 and 40 percent, respectively, with the third reactor as the noninoculated control. Wood samples were taken from each reactor to determine the initial PCP concentrations. Humidified air was delivered daily for 30 minutes through the

reactors at a constant rate of 200 ml/min. The bioreactors were incubated at 36 °C for 4 weeks.

After 4 weeks the bioreactors were harvested. The chips from each bioreactor were divided into three harvest levels bounded by the platforms. Each level represented approximately one-third of the chips of the reactor. The chips were harvested sequentially, starting with the upper level. The chips corresponding to a given level were removed and mixed thoroughly. Three subsamples were taken from the chips in each level. Duplicates of each subsample were then analyzed for PCP.

There were decreases in the concentration of PCP in the 40 percent (49 percent PCP decrease) and 20 percent (38 percent PCP decrease) inoculation levels compared to the control (Figure 18). However, the difference was only significant at the 40 percent level. The decreases observed in the inoculated treatments were consistent throughout the three harvest levels, and were not as great as those observed in the previous small scale studies.

Effect of Distance From Aeration Source

The bioreactor consisted of a plastic tub (217 L) 122 cm long x 58 cm wide x 30 cm high. A 2.54-cm diameter PVC tube was fitted into the inside of each end of the reactor against the outside wall. Air holes (0.4 cm diameter), 7.5 cm apart, were drilled into the tubes. A perforated Poly-P platform was fastened 1.3 cm above the tubing, creating an air space of 5 cm between the bottom of the reactor and the underside of the platform. A mixture of PCP-treated hardwood and softwood chips of random sizes (all chips passed a 1.9 cm screen) from PCP-treated ammunition boxes

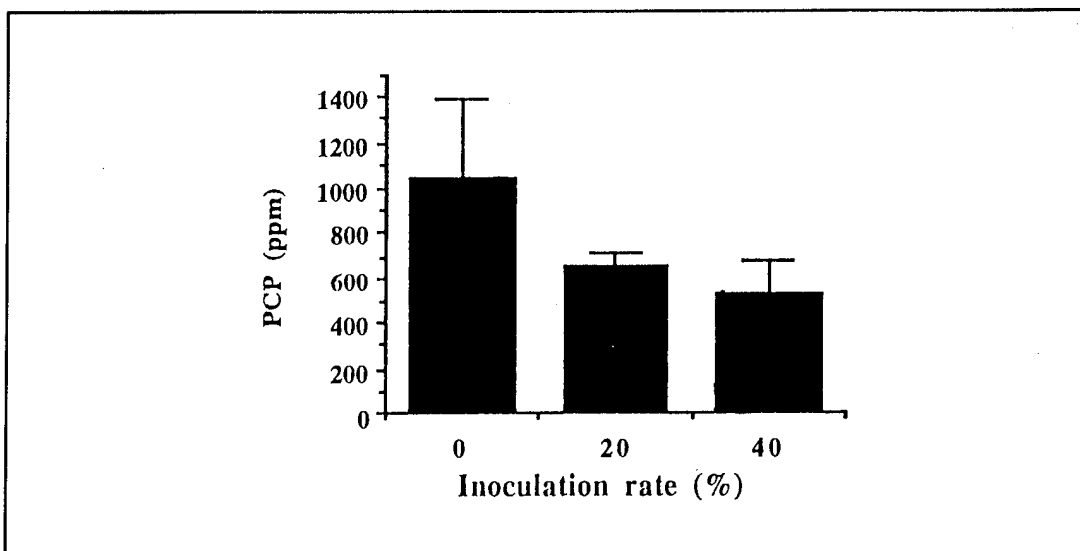

Figure 18. Effect of inoculation rate on PCP concentration in wood chips after 4 weeks incubation in an 8-L bioreactor.

were moistened to 60 percent and inoculated with *T. hirsuta* inoculum at a 25 percent inoculation rate (dry weight of inoculum/dry of wood). The final depth of the chips-inoculum mixture was 22.5 cm. Initial wood chip samples were collected and analyzed by the new extraction method. Incubation was allowed to proceed in the reactor, which was open to ambient air, for 4 weeks at 25 °C. Aeration consisted of humidified air delivered once a day for 45 minutes simultaneously to both tubes.

After 4 weeks, the chips were harvested. To determine the effects of aeration, the chips were sampled by depth and distance from the air sources. For this purpose the bioreactor was divided into A and B sides, and each side was divided into vertical intervals away from each aeration source (0 to 7.5, 10 to 15, 18 to 30, 33 to 45, and 48 to 60 cm to the middle of the reactor). This was repeated on three different levels; the top 7.5 cm, the middle 7.5 cm, and the bottom 7.5 cm. This same sampling procedure was repeated on both sides of the reactor to develop duplicates.

On the A side of the reactor, depletion of PCP in the top and middle layers averaged 80 percent (Figure 19). The bottom layer generally also had a high level of PCP depletion ranging from 60 to 80 percent except at a distance of about 30 cm from the air source. The B side of the reactor contained more variation. The top and bottom layers showed general decreases in the percent PCP depletion as the distance from the air source increased. The middle layer showed little variation over distance with an average of 70 percent PCP depletion (Figure 20).

The lack of a significant PCP depletion on the B side bottom layer at more than 25 cm from the aeration source was probably due to (1) inadequate mixing of the inoculum that resulted in a lack of fungal growth in this area, or (2) a preponderance of smaller chips in this area that packed and inhibited adequate aeration.

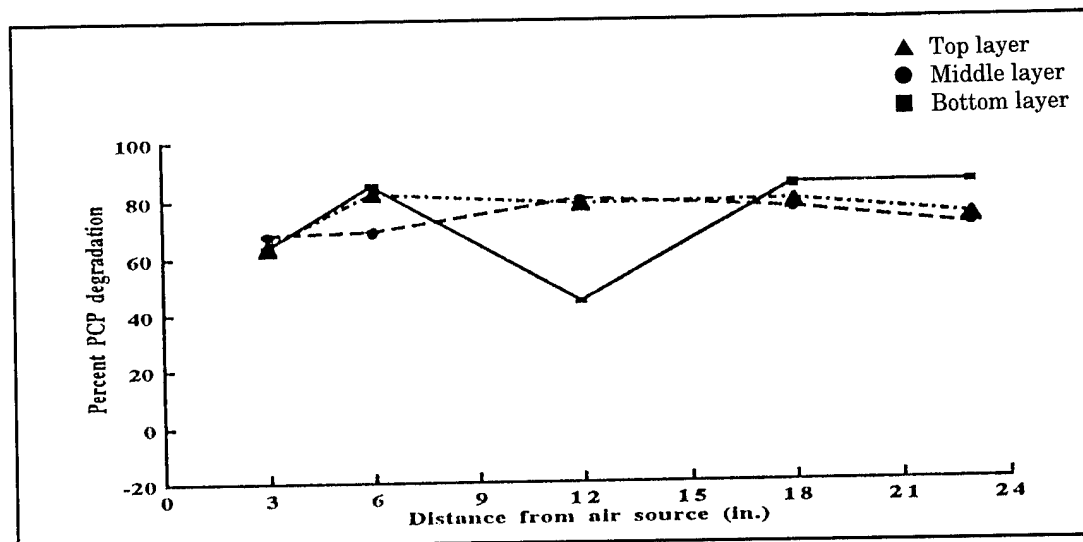

Figure 19. Side A of the bioreactor.

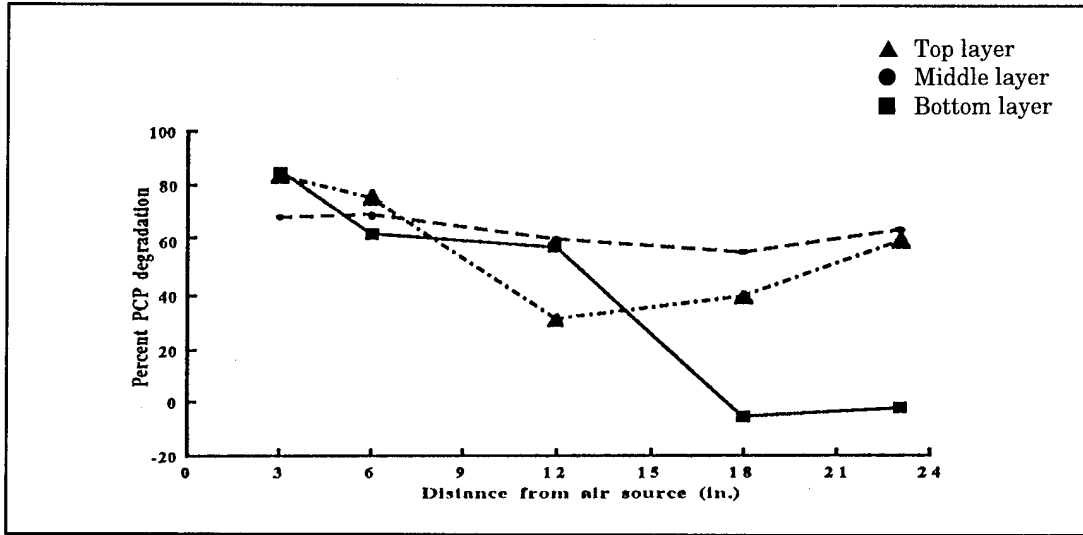

Figure 20. Side B of the bioreactor.

7 Field Evaluation of the Fungal Depletion of PCP-treated Ammunition Boxes

The purpose of this field study at Letterkenny Army Depot was to evaluate, on a large scale, the effectiveness of a solid substrate fungal treatment for removal of PCP from wood from PCP-treated ammunition boxes.

The fungal inoculum consisted of *T. hirsuta* grown on a solid substrate mixture at 60 percent moisture. A spawn company was responsible for producing and delivering this inoculum.

Ammunition boxes selected for this study were primarily softwood with additional hardwood and metal components (nails and hinges) as supports. Depot personnel loaded and transported 175 ammunition boxes to the experimental area. After the boxes had been disassembled and all metal hinges and components removed, a private contractor was hired to bring a chipper to the site, chip the boxes to 3/4- to 1-inch lengths, and complete additional precautions needed for processing the PCP-treated wood, including decontaminating the chipping equipment.

The field evaluation was conducted in a well ventilated building; the experimental area was 9 m by 15 m. Ambient temperature in this facility was maintained at 25 °C. Initially, eight plots were assembled and covered with 20 mil plastic to protect from PCP contamination. The plots consisted of platforms constructed of two 2.4 x 1.2 m plywood sheets fixed on top of a base that had a 1-inch gradient across the width. A 10-cm wide gutter, constructed from PVC pipe cut lengthwise, was attached to the lower edge of the platform. Each platform had a central collection point for the run-off leachate from the gutters. The leachate was recycled back onto the chips. The platforms served to prevent PCP contamination of the building floor.

The wood chips for the control plots were adjusted to 60 percent moisture content using tap water. Wood chips for the inoculated plots were mixed with *T. hirsuta* inoculum to achieve an inoculation rate of 25 percent and then were wet up to 60 percent moisture content. The chips-inoculum mixture was then placed on the platforms in an alternating pattern (Figure 21) The noninoculated chips were then placed on the remaining platforms. The plot placements were assigned to account for

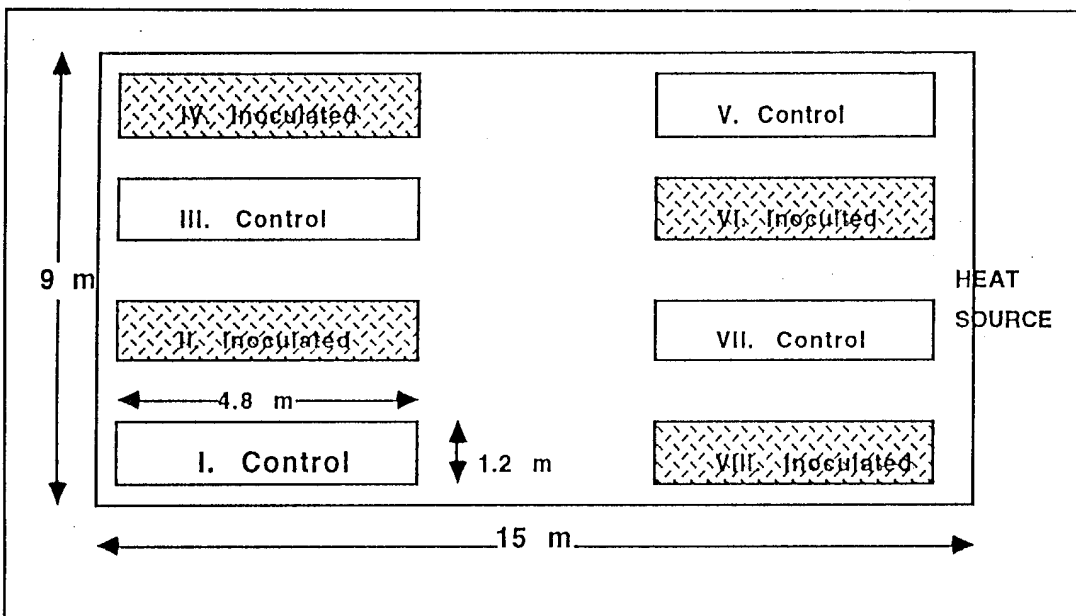

Figure 21. Experimental site.

temperature variations in the building. This study consisted of four control plots and four inoculated plots. Each plot contained 130 kg (wet weight) of wood.

Duties performed four times a week included:

- take moisture readings and maintain a record of moisture and temperature readings,
- wet the windrows, maintain chip moisture content (60 percent),
- overturn the wood chips for aeration, and
- sample wood chips at designated times.

The sampling intervals were at day 1 (initial) and on weeks 1, 2, 4, and 8. For sampling, each plot was divided equally into four quadrants (4 ft by 4 ft) designated A, B, C, D, with the A quadrant being farthest from the heating source and D closest (Figure 21). Five random samples were taken from each quadrant. Wood samples were then shipped to Forest Products Laboratory (FPL) for analysis. The laboratory analysis of the wood chips consisted of:

- determining PCP concentrations from the wood by the acetone extraction procedure, and
- determining the amount of fungal growth in the wood by analyzing for ergosterol levels (a sterol present in fungal cell membranes).

The collected samples from each quadrant were pooled, thoroughly mixed, and then ground to approximately 1 mm in size using a coffee mill. The moisture content of each sample was determined gravimetrically after drying at 80 °C for more than

18 hours. For ergosterol determinations, wood chip samples in 25 x 150 mm culture tubes with Teflon-lined screw caps were placed in 20 ml methanol and stored at -20 °C until they were extracted. Before extraction, 2.0 g KOH (Potassium hydroxide) pellets and 5 ml hexane were added to each tube and the tubes were placed on a rotating tumbler and shaker for 18 hours at room temperature. After shaking, 5 ml distilled water was added (about 20 percent of methanol volume) and the tubes vigorously shaken. Following clarification of the aqueous phase (about 30 minutes), the hexane layer was transferred to 12 ml amber screw cap vials. Two additional hexane extractions (5 ml) were performed and the pooled extractions were evaporated to dryness under nitrogen. The samples were solubilized in 0.5 ml methanol by heating at 60 °C for 30 minutes. To determine any solvent evaporation during solubilization, weights were taken before heating and also immediately before filtering through 0.45 µm acrodisc filters. The ergosterol in the methanol solution was quantified by high pressure liquid chromatography. There was a 30 percent PCP decrease in chips from the inoculated plots and no decrease in the controls (Figure 22).

The level of ergosterol is correlated to the level of active fungal biomass. The ergosterol levels of chips in the inoculated plots decreased greatly between days 1 and 7 (Figure 23). This may have been the result of dehydration of the chips that occurred during the extended weekend after the study was installed or simply a shock to the fungus upon exposure to the PCP in the chips. However, once the moisture content was restored, the ergosterol levels increased to their previous high indicating regrowth of the fungus. However, ergosterol levels never increased much beyond the initial values, indicating that fungal colonization of the inoculated chips was not extensive.

The low percent depletion observed in the field study was probably due to a combination of several factors including: incubation temperatures that were much lower than is optimum for the growth of *T. hirsuta* (36 °C), dehydration of the chips

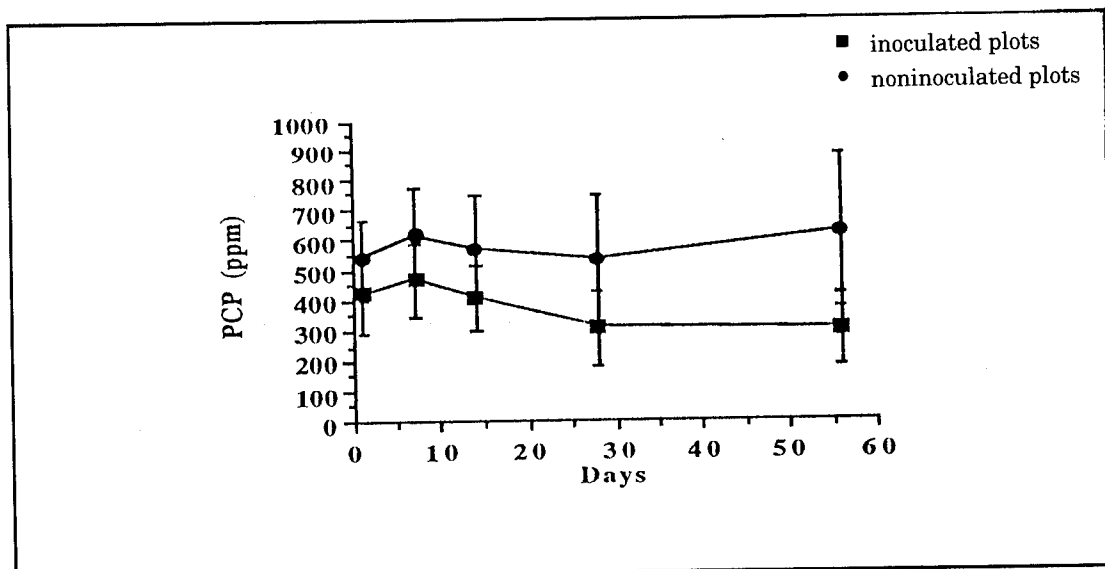

Figure 22. Effect of incubation time of *T. hirsuta* versus levels of PCP from the wood chips.

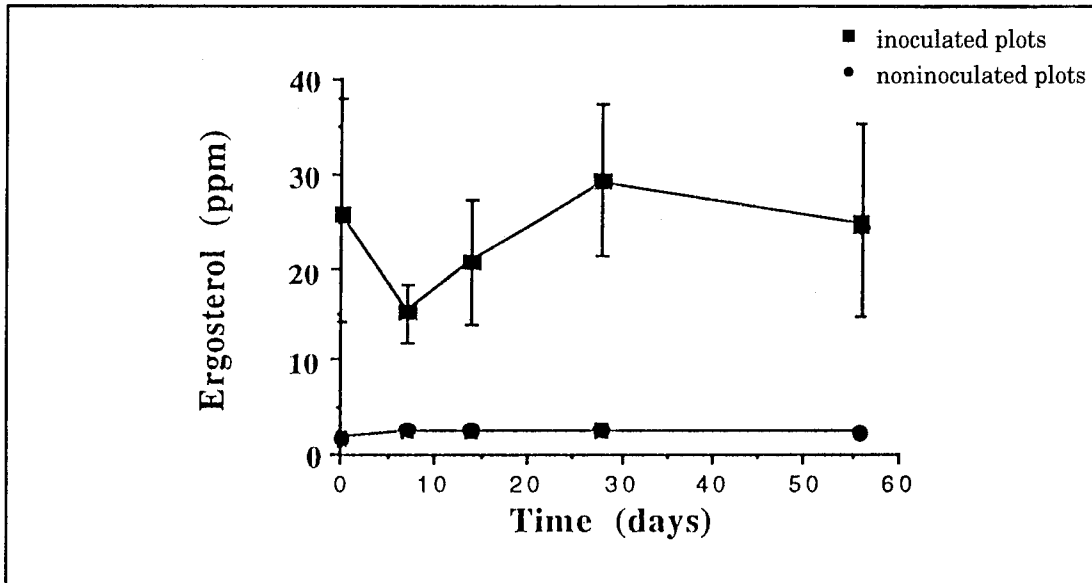

Figure 23. Effect of time on the ergosterol level present in the wood chips.

on weekends when access to the study area could not be obtained, and the inoculum potential. The first two factors are self-explanatory. Although researchers could not obtain the data on daily temperatures and moistures, the air temperature in the study area was below 36 °C and the chips dried out over the weekend. Currently, a method for evaluating the inoculum potential does not exist. The inoculum used in this experiment was prepared and then stored for 3 months at 4 °C because of delays in obtaining a study site. Therefore, the advanced age of the fungal culture and lower nutritional status of the substrate, relative to what had been used in previous laboratory experiments, could have been the major factor affecting the inability of *T. hirsuta* to effectively colonize the inoculated chip volume.

Field Demonstration Conclusions

There was a 30 percent decrease in the PCP concentration compared with the control. This is considerably less than obtained under ideal laboratory conditions (80 percent), which may reflect a number of variables that could not easily be controlled under the conditions of this study. The lack of fungal growth in the inoculum indicated a low inoculum potential that probably contributed to the low fungal growth, as indicated by the ergosterol levels, throughout the study. Incomplete colonization of the inoculated chips resulted in significantly less PCP decrease than was observed under ideal laboratory conditions. However, this study demonstrated the feasibility of this approach in reducing PCP in treated wood. Laboratory studies show that, under ideal conditions, it is possible to reduce the PCP concentration by 80 percent. This field study showed only a 30 percent reduction in PCP concentration. This decrease occurred under less than ideal conditions; further studies may yield more promising results.

8 Conclusions and Recommendations

White-rot fungi effectively decreased the PCP concentration of PCP-contaminated hardwood and softwood chips.

The fungal species used varied greatly in their abilities to effect dry weight losses and decreases in the PCP concentration of the chips and in their metabolism of PCP in a chip environment.

Nutrient supplementation was important for obtaining substantial dry weight losses but not for PCP decreases. However, greater dry weight losses generally were associated with greater percentage decreases of PCP, but this depended on the nutrient supplement. Since the primary concern is complete destruction of the PCP, optimization of the fungal treatment process should be focused on PCP removal versus weight loss.

Chip sterilization was important to rapid dry weight loss and PCP depletion when the fungi did not compete well with the indigenous microbes in nonsterile chips. Dry weight loss in softwood chips inoculated with *P. chrysosporium* was increased more than 3-fold by sterilization. However, it appears that, over time, the white-rot fungi were able to outcompete the indigenous organisms, colonize the chips, and transform the PCP. Chip sterilization can be avoided by identifying fungi that can outcompete the indigenous microbes and rapidly and completely colonize the chips.

Based on these studies *T. hirsuta* was selected for additional investigation. *T. hirsuta* is a wood-degrading fungus that has a high sensitivity to PCP and a relatively high temperature optimum (i.e., 36 °C). Its high temperature optimum is not a liability because treatment of large amounts of chips will probably generate temperatures in excess of 36 °C. Temperature either in reactors or piles can be manipulated using aeration. Despite its high sensitivity to PCP, this organism caused an 84 percent depletion of PCP in chips from PCP-treated ammunition boxes in 4 weeks. The depletion was a result of either complete breakdown of about 27 percent of the PCP (i.e., mineralization) or transformation of about 66 percent of the PCP to innocuous products. Only 6 percent remained unchanged. These results indicate that this fungus has the potential to be an effective biological agent in a treatment method for the disposal of PCP-treated wood. Results from the bioreactor experiments

demonstrated that adequate aeration, inoculum type, and placement of the inoculum are key factors to consider in further design of the method. These factors are critical to obtaining adequate fungal growth. Further studies are needed to optimize:

- delivery of adequate aeration throughout the chip volume,
- the ratio of inoculum to chips that ensures copious fungal growth, and
- the optimum placement of the inoculum.

Environmental parameters for optimal degradation were determined, and found to include a temperature of 36 °C, an inoculation rate varying with initial PCP concentration, and moisture of 60 percent using solid phase inoculation.

A new protocol for extraction of PCP from wood was devised, based on an extraction procedure used to extract PCP from soil. The modifications consisted of the substitution of acetone for hexane as an extracting solvent and an increase of the extraction number from two to three. The ideal chip size for extraction was 30 mesh.

Cultivation of *T. hirsuta* in liquid medium in PCP-treated wood inhibited growth of the fungus and therefore, did not result in PCP degradation.

In experiments carried out on solid substrate in a large scale bioreactor, an 80 percent decrease in the PCP concentration was observed.

A field study was initiated using PCP impregnated ammunition boxes. There was a 30 percent decrease in the PCP concentration compared with the controls. This is considerably less than obtained under ideal laboratory conditions (80 percent), which may reflect a number of variables that could not easily be controlled under the conditions of the study. The lack of fungal growth in the inoculum indicated a low inoculum potential that probably contributed to the low fungal growth, as indicated by the ergosterol levels, throughout the study. Incomplete colonization of the inoculated chips resulted in significantly less PCP decrease than was observed under ideal laboratory conditions. However, this study demonstrated the feasibility of this approach in reducing PCP in treated wood. Laboratory studies show that, under ideal conditions, it is possible to reduce the PCP concentration by 80 percent. Although the field study showed only a 30 percent reduction in PCP concentration, this decrease occurred under less than ideal conditions; further studies may yield more promising results.

Further research on inoculum formulation and quality and on manipulation of environmental conditions that optimize growth of *T. hirsuta* is needed to make this technology a commercially viable treatment alternative.

REFERENCES

- Brown, J.A., J.K. Glenn, and M.H. Gold, "Manganese Peroxidase Gene Transcription in *Phanerochaete chrysosporium*," *Journal of Bacteriology*, vol 172 (1990), pp 3125-3130.
- Code of Federal Regulations, Volume 40, Part 261, "Identification and listing of hazardous waste," Revised July 1, 1990 (Office of the Federal Register, National Archives and Records Administration, 1990).
- Davis, M.W., and R.T. Lamar, "Evaluation of Methods To Extract Ergosterol for Quantitation of Soil Fungal Biomass," *Soil Biology and Biochemistry* (1991).
- Electric Power Research Institute, EPRI Report EN-7062, *Pentachlorophenol (PCP) Treated Wood Poles and Crossarms: Toxicity Characteristic Leaching Procedure Results* (EPRI, 1990).
- Evans, C.S., et al., "Localization of Degradative Enzymes in White-rot Decay of Lignocellulose," *Biodegradation* (1991).
- Kirk, T.K., E. Schultz, W.J. Connors, L.F. Lorenz, and J.G. Zeikus, "Influence of Culture Parameters on Lignin Metabolism by *Phanerochaete chrysosporium*," *Arch. Microbiology*, vol 117 (1978), pp. 277-285.
- Lamar, R.T., and D.M. Dietrich, "In situ Depletion of Pentachlorophenol From Contaminated Soil by *Phanerochaete* spp.," *Applied Environmental Microbiology*, vol 56 (1990), pp 3093-31.
- Lamar, R.T., and D.M. Dietrich, "Use of Lignin-degrading Fungi in the Disposal of Pentachlorophenol-treated Wood," *Journal of Industrial Microbiology*, vol 9 (1992), pp 181-191.
- Lamar, R.T., J.A. Glaser, and T.K. Kirk, "Fate of Pentachlorophenol (PCP) in Sterile Soils Inoculated With the White-rot Basidiomycete *Phanerochaete chrysosporium*: Mineralization, Volatilization, and Depletion of PCP," *Soil Biology and Biochemistry*, vol 22 (1990), pp 433-440.
- Lamar, R.T., M.J. Larsen, and T.K. Kirk, "Sensitivity to and Degradation of Pentachlorophenol by *Phanerochaete* spp.," *Applied and Environmental Microbiology*, vol 56 (1990), pp 3519-3526.
- Lin, J.E., H.Y. Wang, and R.F. Hickey, "Degradation Kinetics of Pentachlorophenol by *Phanerochaete chrysosporium*," *Biotechnology and Bioengineering*, vol 35 (1990), pp 1125-1134.
- Mileski, G.J., et al., "Biodegradation of Pentachlorophenol by the White Rot Fungus *Phanerochaete chrysosporium*," *Applied and Environmental Microbiology*, vol 54 (1988), pp 2885-2889.

National Toxicology Program, *Toxicology and Carcinogenesis Studies of Two Pentachlorophenol Technical-grade Mixtures (CAS No. 87-86-5) in B6C3F1 Mice (Feed Studies)*, Technical Report Series No. 349 (U.S. Department of Health and Human Services, 1989).

Nobles, M.K., "Identification of Cultures of Wood-inhabiting Hymenomyces," *Canadian Journal of Botany*, vol 43 (1965), pp 1097-1139.

Otjen, L., et al., Assessment of 30 White Rot Basidiomycetes for Selective Lignin Degradation," *Holzforschung*, vol 41 (1987), pp 343-349.

Strum, C.V., and P. Merrell, *The Politics of Penta* (Greenpeace U.S.A., Seattle, Washington, 1989).

USACERL DISTRIBUTION

Chief of Engineers

ATTN: CEHEC-IM-LH (2)

ATTN: CEHEC-IM-LP (2)

ATTN: CECC-R

ATTN: CERD-L

Army Environmental Office

ATTN: ENVR-E

ATTN: ENAEC-TS

Defense Technical Info Center 22304

ATTN: DTIC-FAB (2)

10

10/94