

NATIONAL AIR INTELLIGENCE CENTER

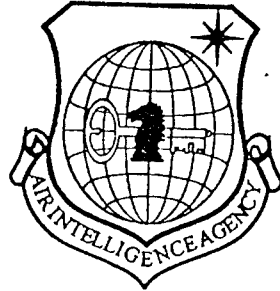

10 KW HEAT PIPE-HEAT SINK DEVELOPMENT

by

Qiu Chengti, Xie Deren

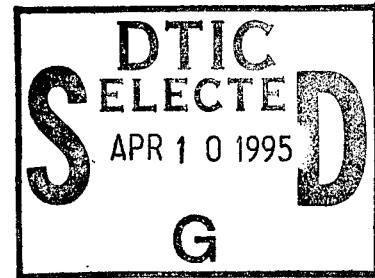

DTIC QUALITY INSPECTED 5

Approved for public release;
Distribution unlimited.

19950407 088

Accession For	
NTIS CRA&I	<input checked="" type="checkbox"/>
DTIC TAB	<input type="checkbox"/>
Unannounced	<input type="checkbox"/>
Justification _____	
By _____	
Distribution/ _____	
Availability Codes	
Dist	Avail and/or Special
A-1	

HUMAN TRANSLATION

NAIC-ID(RS)T-0495-94 27 March 1995

MICROFICHE NR: 95C000116

10 KW HEAT PIPE-HEAT SINK DEVELOPMENT

By: Qiu Chengti, Xie Deren

English pages: 16

Source: Nanjing Gongxueyuan Xuebao, Vol. 16, Nr. 4, 1986;
pp. 76-85

Country of origin: China

Translated by: Leo Kanner Associates
F33657-88-D-2188

Requester: NAIC/TATD/Lt Jim Shell

Approved for public release; Distribution unlimited.

THIS TRANSLATION IS A RENDITION OF THE ORIGINAL FOREIGN TEXT WITHOUT ANY ANALYTICAL OR EDITORIAL COMMENT STATEMENTS OR THEORIES ADVOCATED OR IMPLIED ARE THOSE OF THE SOURCE AND DO NOT NECESSARILY REFLECT THE POSITION OR OPINION OF THE NATIONAL AIR INTELLIGENCE CENTER.	PREPARED BY: TRANSLATION SERVICES NATIONAL AIR INTELLIGENCE CENTER WPAFB, OHIO
--	---

GRAPHICS DISCLAIMER

All figures, graphics, tables, equations, etc. merged into this translation were extracted from the best quality copy available.

10 kW HEAT PIPE-HEAT SINK DEVELOPMENT

by

Qiu Chengti and Xie Deren

Source: 10 kW Reguan Sanreqi Di Yanzhi, NANJING
GONGXUEYUAN XUEBAO [JOURNAL OF NANJING
ENGINEERING COLLEGE], Vol. 16, No. 4, 1986

Pages Translated: 76-85

Words Translated:

Translation No.: NAIC-ID(RS)T-0495-94

Contractor: LEO KANNER ASSOCIATES
Redwood City, California

10kW HEAT PIPE-HEAT SINK DEVELOPMENT

Qie Chengti and Xie Deren, of department of mechanical engineering, Nanjing Engineering College

ABSTRACT

A design of heat pipe with heat sink for cooling 10kW klystron is presented. The radial heat pipe with heat sink is adopted and the later is optimized by computer for its minimum weight. In order to find its performance and life, the life testing is made and lasted for 1154 hours under the dissipated 5kW condition in addition to the traditional performance testing. The results obtained show that this heat pipe with heat sink is reliable, and with which the calculation results are consistent.

Key words: cooling technique, electronic equipment, heat pipe, heat sink.

I. Foreword

The heat pipe is a new high-efficiency device for heat transfer. If the heat pipe is rationally employed in cooling and isothermal systems of electronic equipment, not only can the potential capability of such equipment be exploited, in addition to upgrading operating reliability, but it also has the following advantages: system simplification, cost reduction, as well as reduction of environmental pollution due to noise. To promote the applications of the new heat pipe technique, the authors conducted a series analysis, design and experiments on problems (heat pipe performance, contact heat resistance, service life,

and costs, among other areas) of general concern in the authors' development of a 10kW (KF-115) klystron used in a heat pipe-heat sink. Relatively good results were obtained.

When the power applied was 7kW, the anode temperature was 164°C. The blower power was reduced to 160W from 750kW previously. The contact heat resistance between the anode and the hot terminal of the heat pipe was 7.78×10^{-4} °C/W. To evaluate the service life of the heat pipe-heat sink, to date the setup was operated for 1154 hours at about 5kW power. The results proved that the heat pipe still maintains its original performance indicators. It is apparent that this heat pipe-heat sink setup has reached the predetermined design requirements. Therefore, the heat pipe-heat sink is a heat dissipation unit deserving of widespread applications.

II. Design of Heat Pipe-Heat Sink

Based on the structural features and the requirements of the application conditions of a klystron, the radial heat pipe-heat sink was selected. By utilizing the feature of heat conduction with a heat pipe, the quantity of heat at the anode was effectively transmitted to heat dissipation sheets passing through the hot terminal of the heat pipe to its cold terminal. Then a forced-air cooling method was applied to carry away the heat. Since the area ratio was 1:2.75 between the hot and cold terminals of the heat pipe, the heat flow density of the heat dissipation sheets was reduced from 48.14 to 17.49W/cm². Moreover, by increasing the number of heat dissipation sheets at the cold terminal, a larger heat dissipation area can be obtained. Fig. 1 shows the structural diagram of the heat pipe-heat sink.

1. Heat pipe design

Besides ensuring the required power in transmission for heat pipe design, the design should mainly consider reducing the heat

resistance in the heat conduction process in the heat pipe, in addition to increasing the heat pipe service life.

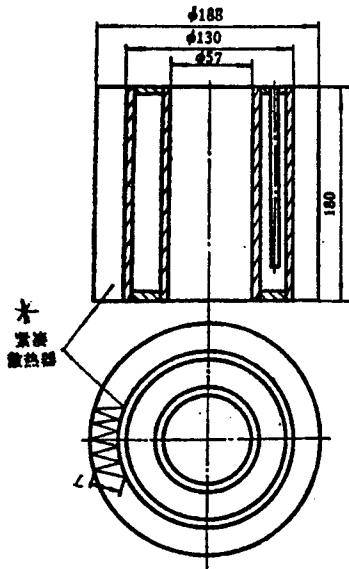

Fig. 1. Heat pipe-heat sink
KEY: * - Compact heat sink

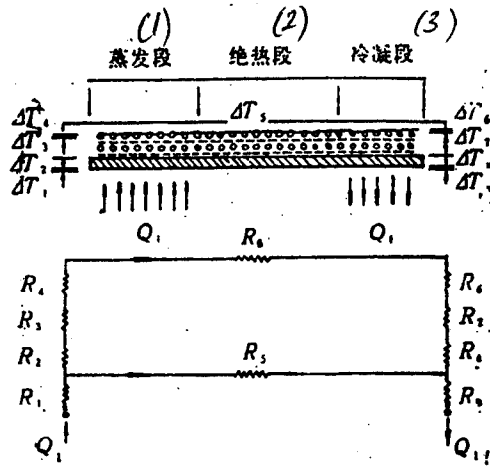

Fig. 2. Heat resistance of heat pipe
KEY: 1 - Evaporation section
2 - Adiabatic section 3 - Cooling and condensing section

The heat resistance of a heat pipe will affect heat conduction performance. The smaller the temperature difference between the heat pipe's hot and cold terminals, the higher is the heat conduction efficiency. However, the temperature difference between the cold and hot terminals is determined by the overall heat resistance in the heat conduction process of the heat pipe, as shown in Fig. 2. Some heat resistance is difficult to be eliminated and reduced; only the heat resistances R_3 and R_7 of the pipe core structure vary with the pipe core structure. For example, the core structure of a flushing slotted pipe can be used to reduce or eliminate R_3 and R_7 . However, the heat resistance for the core structure of silk braided pipe is greater

as its value varies with different techniques. As proved with an experiment on sample pipe, the temperature difference between two heat pipe terminals for a silk braided pipe core structure was greater by a factor of 2.3 than for the core structure of a flushing slot pipe, as shown in Fig. 3. Therefore, the heat pipe mentioned in the article title adopts the core structure of a flushing slot pipe.

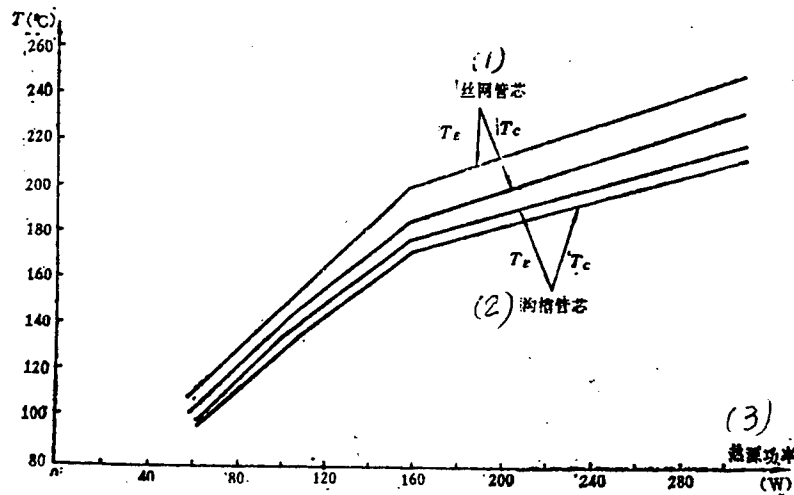

Fig. 3. Heat conduction performance of two kinds of pipe core structure
 KEY: 1 - Silk braided pipe core 2 - Flushing slot pipe core 3 - Power of heat source

The service life of a heat pipe is determined by the compatibility and technique of the materials selected. Since this heat pipe should be combined with the anode of a klystron and also consideration should be given to the physical properties and compatibility of the working medium, therefore oxygen-free copper was used for the pipe shell material, and water was used for the working medium. It is worthwhile to note that the saturation steam temperature of water is high, as high as 53.75×10^5 Pa at 273°C . To ensure operational safety and reliability of the heat pipes, it is appropriate to control the operating temperature of the heat pipe below 200°C at this point;

the steam pressure is $15.44 \times 10^3 \text{Pa}$).

A calculation was carried out based on the heat flow of the capillary limit to the heat pipe, which will transmit a quantity of heat equal to 10kW.

2. Optimizing the heat sink design

Based on the conditions of application of the heat pipe-heat sink, the volume and weight of the setup should not be too large. Therefore, there are problems of model selection and optimization in heat sink design. By analyzing the properties and operating conditions of various kinds of heat sinks, a compact heat sink (as shown in Fig. 1) is selected, thus easily satisfying the requirement for volume miniaturization.

In order to have the lowest weight of the heat sink, an optimization technique can be applied by using the minimum weight as the target function. Based on the shape of this structure, the target function can be written as:

$$W = L \times B \times N \times \gamma \times H .$$

However, the requirements of performance and structural rationalization should be satisfied for minimum structural weight. In other words, the heat dissipation indicators and spatial dimensions should be satisfied; these are called the performance constraint Q and the boundary constraint. Based on the heat equilibrium equation, the amount of heat dissipated by the heat sink can be derived. The working formula is:

$$Q = C_p \gamma V S_a \Delta t , \quad (1)$$

In the equation, the air circulation area is

$$S_a = \frac{\pi}{4} (D_o^2 - D_i^2) - LNB ,$$

The temperature difference for the air entering and leaving the heat sink is

$$\Delta t = \frac{\eta_s St \left(\frac{H}{r_s} \right) (t_{m.s.s} - t_s)}{1 + \eta_s St \frac{H}{r_s}} ,$$

The heat conduction efficiency of the heat dissipation sheets is

$$\eta_s = \frac{e^{mL} - e^{-mL}}{(e^{mL} + e^{-mL}) mL} ,$$

The equivalent diameter is

$$de = \frac{4S_w}{p} = 4r_s ,$$

The length of the wetted circumference is

$$p = 2NL_s + \pi(D_o + D_i) - 2NB ,$$

$$m = \sqrt{\frac{2h}{\lambda_{cs} \times B}} ,$$

The heat conduction coefficient is

$$h = \frac{C_p \mu}{Pr^{1/3} d_s} (St Pr^{1/3}) R_s ,$$

The Reynolds number is

$$R_s = \frac{V d_s}{\nu} .$$

By substituting S_w and Δt thus derived into Eq. (1), then we can obtain the amount of heat carried away by the heat sink.

The total pressure head loss is

$$P = P_f + P_c + P_v ,$$

In the equation,

$$P_f = f \frac{H}{d_s} \times \frac{\gamma \times V^3}{2g} , \quad f = \frac{64}{R_s} ,$$

$$P_v = \frac{\gamma V^3}{2g} ,$$

$$P_c = P_v [2(1 - \sigma^2) + K_o - K_i] ,$$

$$\sigma = \frac{4S_w}{\pi D_o^2} .$$

When R_s is less than 2000,

$$K_o = 1.245 + 0.1\sigma - 0.5\sigma^2 + 8.43 \cdot 10^{-9}\sigma^3 ,$$

$$K_i = 0.995 - 2.85\sigma + 0.99\sigma^2 + 1.36 \cdot 10^{-9}\sigma^3 .$$

When R_s is greater than 2000,

$$K_o = 0.693 - 0.5937\sigma + 0.687\sigma^2 - 0.6255\sigma^3 ,$$

$$K_i = 0.838 - 1.21\sigma - 0.8125\sigma^2 + 1.0417\sigma^3 .$$

The overall weight of the heat sink is

$$W = LBHN\gamma.$$

By analyzing the above-mentioned formulas, we know that Q is related to the structural dimensions of the heat sink; this is an implicit-functional relation. In addition, it is also related to the restraining conditions on the boundary. Therefore, the design variables of the heat sink are determined as L , N , and H . This is a nonlinear, but optimization-constraint problem. Of course, this kind of problem can be solved by using nonlinear planning, such as the method of penalty function, or the composite-shape method. However, since the constraints of the problem are an implicit function of the variables, including the term η_s of the surpassing function. As the status of the function is less desirable, we conclude that there will be some difficulties in using the nonlinear planning for its resolution; it is also comparatively difficult by selecting a set of suitable initial values. Based on features of the problem, the upper- and lower-limit amplitudes of the variables are smaller as some variables are diffusion variables, therefore the parameter fitting method is employed. Executed on a computer, more than 1000 schemes were derived, and of these the optimal solution is chosen.

4. Analysis of Results of Calculation

Under each constraint, there are more than 1000 schemes for varying the structural parameters. We know the following from

TABLE 1

N	D_o (mm)	H (mm)	B (mm)	R_s	ΔT °C	P (mm)	Q (kW)	W (kg)
$V = 12\text{m/s}$				$T_{max} = 200^\circ\text{C}$				
180*	195	140	0.3	2976	53	27.2	10.067	2.27
180	19.5	140	0.4	2976	56	27.7	10.27	3.12
220	180	170	0.4	2139	79.6	34.6	10.15	3.8
230	180	160	0.4	2032	79.5	35	10.03	3.28
250	180	150	0.4	1844	81	44	10.04	3.34
250	185	130	0.5	1776	77.3	43.2	10.046	3.98
$V = 12\text{m/s}$				$T_{max} = 180^\circ\text{C}$				
200*	200	140	0.3	2721	48.8	28	10.018	2.62
220	185	180	0.4	2192	69.9	34.6	10.003	3.88
230	185	180	0.5	1971	75	44.8	10.01	5.07
250	185	160	0.5	1776	76.9	47	10.007	5.2
180	195	140	0.3	2480	51.2	19.6	8.1	2.27
$V = 10\text{m/s}$				$T_{max} = 180^\circ\text{C}$				
230*	195	160	0.3	1910	65.5	28.9	10.019	3.19
250	195	150	0.5	1552	75	32	10.057	5.4
230	195	150	0.5	1721	73.7	30.8	10.092	5.3
210	195	170	0.5	1921	71.6	29	10.058	5.16
210	195	170	0.4	2015	68	23.2	10.064	4.1
$V = 10\text{m/s}$				$T_{max} = 200^\circ\text{C}$				
190*	200	150	0.3	2872		27.8	10.045	2.66

* Optimal design under the same constraints

analyzing the results of the calculation. Under the same constraint, the weight ratio of the lightest and the heaviest heat sink with the same dissipation power lies between a factor of 1.7 and a factor of 1.94. Moreover, the wind pressure head loss was also greater for a heavier heat sink, about 60% more. By increasing the heat dissipation sheets by 0.1mm, the heat dissipation capability was increased by only 2%, however the weight goes up by 37%. With the same structure and wind velocity, by appropriately increasing the operating temperature, such as from 180 to 200°C, the heat dissipation capability can be made 24% higher. With the same structure and operating temperature, by raising the wind velocity from 10 to 12m/s, the heat dissipation capability can be increased by about 11.3%. Table 1 lists these data.

IV. Experiments with Heat Pipe-Heat Sink

1. Experiments on performance and service life should be carried out for the heat pipe-heat sink in order to evaluate its performance and service life.

1. Performance experiments

The performance experiments were carried out in two stages. In the first stage, a simulated heat source was used as the heat source of the heat pipe-heat sink. By changing the input voltage and current of the simulated heat source, different powers were obtained. Fig. 4 shows the experimental results. In the second stage, the experiment proceeded in the entire setup, mainly evaluating the practical operating situation of the heat pipe-heat sink. During the experiments, the input power of the klystron was raised to 10kW, and the output power was 3kW. Here there was no anomaly discovered in the operating situation. Later, the input power was adjusted to 7.2kW and the output power, to 1.6kW, for 2h of continuous operation. The entire setup functioned normally.

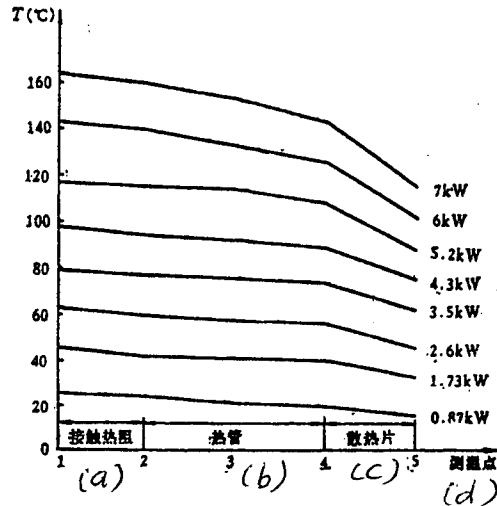

Fig. 4. Performance experiment
 KEY: a - Contact heat resistance b - Heat pipe
 c - Heat dissipation sheets d - Temperature measuring points

As indicated in the performance experimental results of the two above-mentioned stages, all performance values of the heat pipe-heat sink were up to the design requirements.

2. Service life experiment

The service life experiment was carried out in a laboratory. As limited by the power capacity of the laboratory, the loading power of the heat pipe-heat sink was determined to be about 5kW. To date, 1154h of operation were carried out. During the experimental process, there was no attenuation of the heat pipe performance that was detected. Table 2 and Fig. 5 show these data. Fig. 6 shows the positions of the temperature measuring points.

TABLE 2

功率 (a) (kW)	小时 (b)	(c) 测温点温度 (°C)			
		1	2	3	4
4.9	1	107.8	105.7	98	76.8
4.3	113	97	94.9	90	69.6
5.4	191	119	115.9	109	84.6
5.2	301	115	113	108	83.3
5.3	394	116	113	110.4	85.5
4.7	509	103.5	102.4	92.8	66.68
4.7	645	103.5	102.4	95.5	69.98
7	653	153.4	149.4	139.4	102.8
6.5	663	147.4	144.5	129.7	94.8
4.4	695	98.12	97	89.1	63.23
4.6	800	100.23	99	93	67
5	1034	109	108.9	105	80
5.2	1087	115	113.9	107.8	81.6
5.15	1154	113	112	101.9	73.9

KEY: a - Power b - Hours c - Temperature measuring points

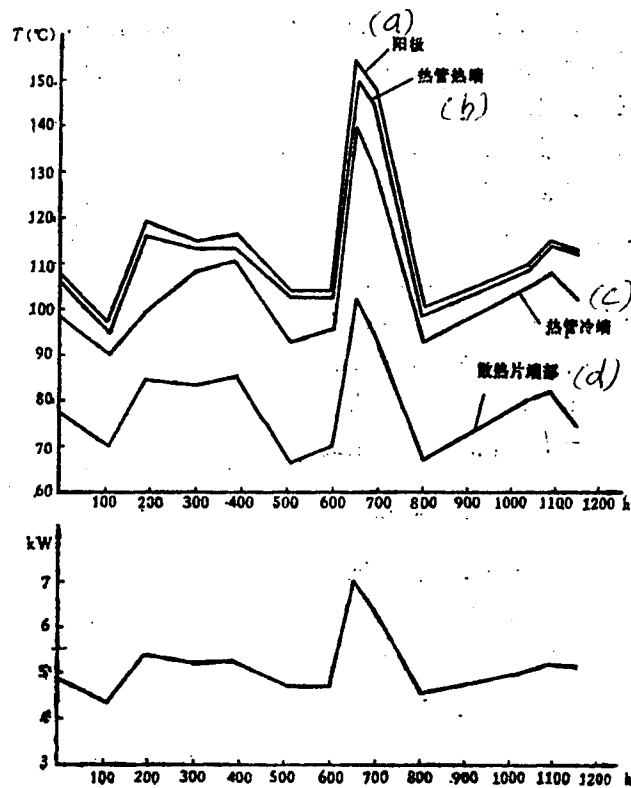

Fig. 5. Service life experiment
 KEY: a - Anode b - Hot terminal of heat pipe
 c - Cold terminal of heat pipe d - Terminal
 portion of heat dissipation sheet

IV. Contact Heat Resistance

Contact heat resistance is induced because of poor contact between the contacting service of the heat liberating apparatus and the heat sink; the magnitude of the heat resistance directly affects the heat conduction capability between the heat liberating apparatus and the heat dissipating apparatus (heat sink). An increase of contact heat resistance will somewhat hinder the heat conduction of the heat regulating apparatus, thus raising the temperature. Operation fails to continue if the heat hindrance is serious. In the design of the temperature control

of the electronic equipment, this problem requires an urgent solution for reducing and eliminating the contact heat resistance. Therefore, several measures are adopted in this development in order to explore a better solution method.

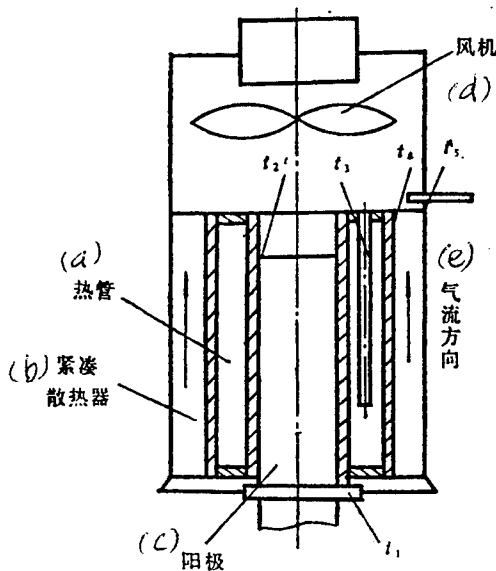

Fig. 6. Temperature measuring position
KEY: a - Heat pipe b - Compact heat sink c - Anode d - Wind blower e - Direction of air current

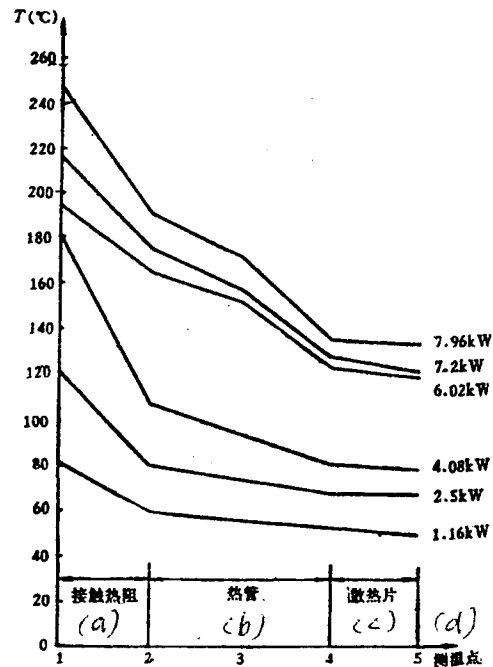

Fig. 7. Performance experiments
KEY: a - Contact heat resistance b - Heat pipe c - Heat dissipation sheets d - Temperature measuring points

1. A layer of heat-conducting grease coats the contact surfaces between the klystron anode and the heat pipe hot terminal. Since the heat-conducting grease only functions at low temperatures, at high temperatures (over 100°C), the heat-conducting grease melts so its function is lost.

2. The contact surface is extended by upgrading the machining accuracy of the two contact surfaces, thus reducing the contact heat resistance. However, as indicated by the experimental results, the contact heat resistance was still very high. The temperature difference was induced from the contact heat resistance; the maximum difference was about 60°C, as shown in Fig. 7.

3. A low-temperature alloy fills the space between the two contact surfaces in order to fill the gap between these two contact surfaces, thus lowering the contact heat resistance. As shown in the experimental results, this method has better results. The contact heat resistance drops down, apparently, as shown in Fig. 4. By comparing with that of Fig. 7, the contact heat resistance can drop by more than one order of magnitude.

V. Conclusions

1. As shown in the experiments, the radial flushing slot pipe core structure: heat pipe-heat sink is used to substitute for the heat sink (heat dissipating apparatus) in the previous design. This is an effective setup to lower the heat current density, to increase the heat dissipation area, and to upgrade the heat conduction capability. Because of the increased areas of heat dissipation and heat flow, the area flow speed is lowered from 20 to 12m/s, thus also lowering the noise. This approach can improve the working environment, be beneficial to the health of operating personnel with higher working efficiency.

2. The optimal design is executed by using an electronic computer. This not only can achieve satisfactory technical indicators in a shorter time, but is also the lowest-weight design, thus providing design criteria for miniaturization and low weight of the electronic equipment. The optimization parameters are as follows: $N=180$, $D_0=190 \times 10^{-3}$, $H=140 \times 10^{-3}$, and $B=0.3 \times 10^{-3}$, for designing the heat sink. The test results are

close to the calculated values.

3. With 1154h of testing of this heat pipe-heat sink, its operational performance values were good, up to the design requirements. The material cost and the machining costs are only about 3% of the klystron price, indicating better technical and economic effect in providing good conditions for small-batch production in the future.

4. The heat conduction performance values remain unchanged for this heat pipe structure operating at various positions.

In summarizing, we find that the heat dissipation is an effective and promotion-worthy method, in using the heat pipe-heat sink for the heat dissipation of high-power or high-power-density power tube.

List of symbols

B	-- thickness of heat dissipation sheet	(m)
C_p	-- specific heat at constant air pressure	(kJ/kg \cdot $^{\circ}$ C)
D_0	-- outer diameter of heat sink	(m)
D_i	-- inner diameter of heat sink	(m)
d_e	-- equivalent diameter	(m)
f	-- coefficient of friction	
H	-- height of heat sink	(m)
K_c	-- coefficient of compression loss of fluid	
K_e	-- coefficient of expansion loss of fluid	
L	-- width of heat dissipating sheet	(m)
N	-- number of heat dissipation sheets	
P_f	-- frictional losses	(N/m 2)
P_c	-- pressure head loss	(N/m 2)
P_r	-- Prandtl number	
P_w	-- loss of velocity head	(N/m 2)
p	-- length of wetted circumference	(m)
Q	-- amount of heat carried away by air	(W)

R_e	-- Reynolds number	
r_c	-- hydraulic radius	(m)
S_w	-- air circulation area	(m ²)
S_t	-- Stanton number	
t_{max}	-- highest heat sink temperature	(°C)
t_a	-- environmental temperature	(°C)
Δt	-- air temperature difference between inlet and exit	(°C)
V	-- fluid velocity	(m/s)
W	-- total weight of heat sink	(kg)
r	-- mass per unit area for air	(N/m ²)
r_{Cu}	-- mass per unit area for copper	(N/m ²)
η_s	-- efficiency of heat dissipation sheet	
λ	-- coefficient of heat conductivity	(W/m·°C)
μ	-- dynamic viscosity of air	(Pa·s)
ν	-- moving viscosity of air	(m ² /s)
σ	-- ratio between free-flowing area and area facing the flow	

The paper was received for publication on 20 April 1985.

REFERENCES

- [1] RCA Corporation: 30kW Heat Pipe Development, AD. 7424. 95, 1971 .
- [2] Kays and London: Compact Heat Exchangers, 2nd ed., McGraw—Hill, New York, 1964.

DISTRIBUTION LIST

DISTRIBUTION DIRECT TO RECIPIENT

<u>ORGANIZATION</u>	<u>MICROFICHE</u>
B085 DIA/RIS-2FI	1
C509 BALLOC509 BALLISTIC RES LAB	1
C510 R&T LABS/AVEADCOM	1
C513 ARRADCOM	1
C535 AVRADCOM/TSARCOM	1
C539 TRASANA	1
Q592 FSTC	4
Q619 MSIC REDSTONE	1
Q008 NTIC	1
Q043 AFMIC-IS	1
E051 HQ USAF/INET	1
E404 AEDC/DOF	1
E408 AFWL	1
E410 AFDIC/IN	1
E429 SD/IND	1
P005 DOE/ISA/DDI	1
P050 CIA/OCR/ADD/SD	2
1051 AFIT/LDE	1
P090 NSA/CDB	1
2206 FSL	1

Microfiche Nbr: FTD95C000116

NAIC-ID(RS)T-0495-94