

*te technical note techn*

# Offshore Next Generation Weather Radar (NEXRAD) OT&E Integration and OT&E Operational Test Final Report

Radame' Martinez  
Baxter Stretcher

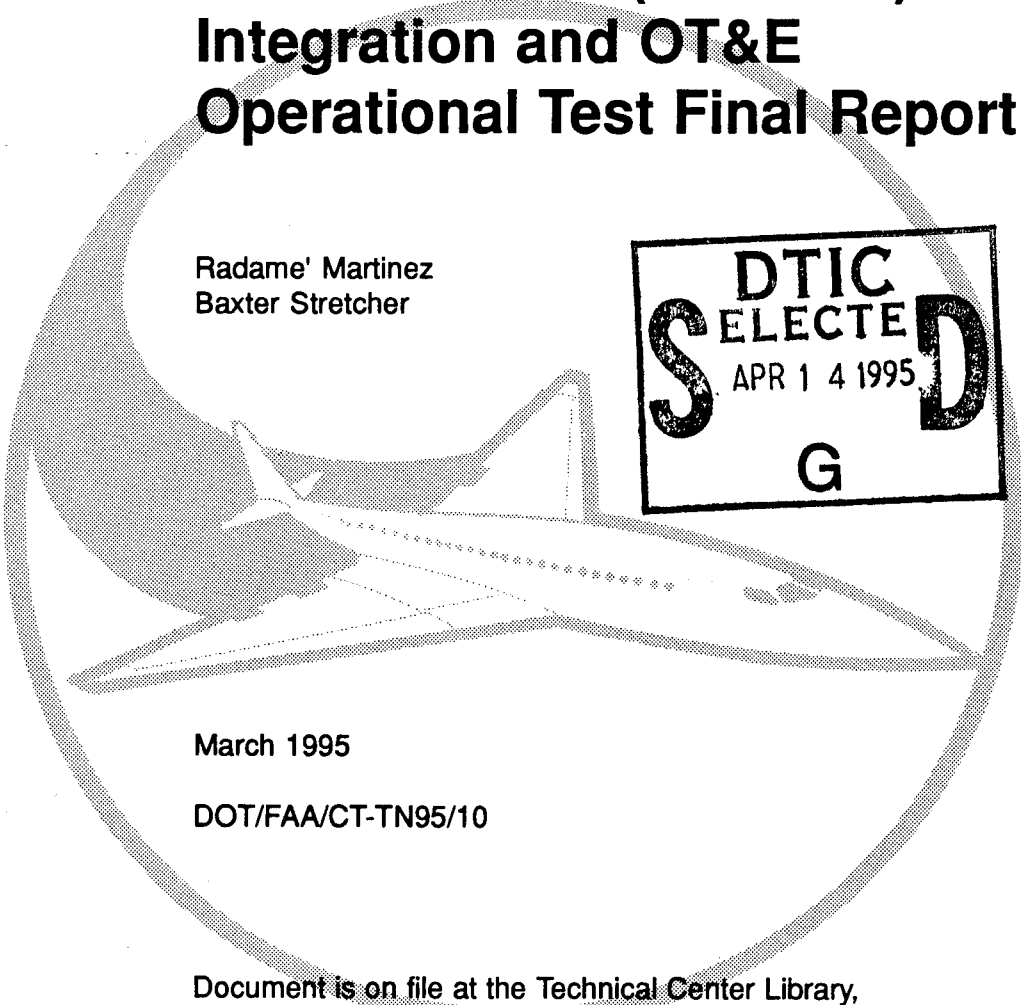
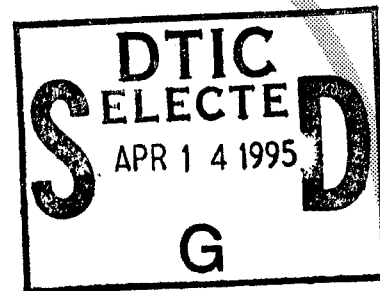

March 1995

DOT/FAA/CT-TN95/10

Document is on file at the Technical Center Library,  
Atlantic City International Airport, N.J. 08405



U.S. Department of Transportation  
Federal Aviation Administration

Technical Center  
Atlantic City Airport, NJ 08405

DTIC QUALITY INSPECTED 8

DISTRIBUTION STATEMENT A  
Approved for public release;  
Distribution Unlimited

19950413 042

## **NOTICE**

**This document is disseminated under the sponsorship of the U.S. Department of Transportation in the interest of information exchange. The United States Government assumes no liability for the contents or use thereof.**

**The United States Government does not endorse products or manufacturers. Trade or manufacturers' names appear herein solely because they are considered essential to the objective of this report.**

<b>1. Report No.</b> DOT/FAA/CT-TN95/10	<b>2. Government Accession No.</b>	<b>3. Recipient's Catalog No.</b>	
<b>4. Title and Subtitle</b> Offshore Next Generation Weather Radar (NEXRAD) OT&E Integration and OT&E Operational Test Final Report		<b>5. Report Date</b> March 1995	
		<b>6. Performing Organization Code</b>	
<b>7. Author(s)</b> Radamé Martinez and Baxter Stretcher, ACW-200; John Porcello, Raytheon; Peter Guthlein and William Diviney, Dimensions International, Inc.		<b>8. Performing Organization Report No.</b> DOT/FAA/CT-TN95/10	
<b>9. Performing Organization Name and Address</b> U.S. Department of Transportation Federal Aviation Administration Technical Center Atlantic City International Airport, NJ 08405		<b>10. Work Unit No (TRAILS)</b>	
		<b>11. Contract or Grant No.</b>	
<b>12. Sponsoring Agency Name and Address</b> U.S. Department of Transportation Federal Aviation Administration Technical Center Atlantic City International Airport, NJ 08405		<b>13. Type of Report and Period Covered</b> Technical Note	
		<b>14. Sponsoring Agency Code</b>	
<b>15. Supplementary Notes</b>			
<b>16. Abstract</b> <p>This document is the Final Report for Phase I limited Operational Test and Evaluation (OT&amp;E) Integration and OT&amp;E Operational testing of the first Federal Aviation Administration (FAA) redundant configuration Next Generation Weather Radar (NEXRAD) installed in Kauai, Hawaii, and provides an account of the results of OT&amp;E testing, including recommendations for future considerations.</p> <p>This report provides background information on the Offshore NEXRAD system. In addition, the report contains a description of testing and evaluation including information about the test schedule and location test participants, specialized test equipment used during testing, test objectives/criteria, test descriptions, test results, and methods used for data collection and analysis.</p> <p>The report continues with a comprehensive discussion of overall test results, including Critical Operational Issues (COI) and their resolution. Finally, the report ends with test conclusions and recommendations to improve system performance.</p>			
<b>17. Key Words</b> Aviation Weather Offshore NEXRAD Radar Data Acquisition (RDA) Unit Control Position (UCP) Redundant Configuration		<b>18. Distribution Statement</b> Document is on file at the Technical Center Library, Atlantic City International Airport, NJ 08405	
<b>19. Security Classif. (of this report)</b> Unclassified	<b>20. Security Classif. (of this page)</b> Unclassified	<b>21. No of pages</b> 76	<b>22. Price</b>

TABLE OF CONTENTS

EXECUTIVE SUMMARY vii

1. INTRODUCTION 1

    1.1 PURPOSE OF REPORT 2

    1.2 SCOPE OF REPORT 2

2. REFERENCE DOCUMENTS 2

    2.1 FAA DOCUMENTS 2

    2.2 OTHER DOCUMENTS 3

    2.3 UNISYS DOCUMENTS 3

3. SYSTEM DESCRIPTION 5

    3.1 MISSION REVIEW 5

    3.2 TEST SYSTEM CONFIGURATION 5

    3.3 INTERFACES 8

4. TEST AND EVALUATION DESCRIPTION 10

    4.1 TEST SCHEDULE AND LOCATIONS 10

    4.2 PARTICIPANTS 11

    4.3 TEST AND SPECIALIZED EQUIPMENT 12

    4.4 TEST OBJECTIVES/CRITERIA 12

    4.5 TESTING DESCRIPTIONS 13

    4.6 DATA COLLECTION AND ANALYSIS METHOD 13

5. RESULTS AND DISCUSSION 13

    5.1 SERVICE REPORTS 14

    5.2 CRITICAL OPERATIONAL ISSUES 17

    5.3 RETESTING 19

6. CONCLUSIONS 19

7. RECOMMENDATIONS 19

8. ACRONYMS AND ABBREVIATIONS 23

APPENDIX

Accession For	
NTIS CRA&I	<input checked="" type="checkbox"/>
DTIC TAB	<input type="checkbox"/>
Unannounced	<input type="checkbox"/>
Justification <i>per form 50</i>	
By _____	
Distribution /	
Availability Codes	
Dist	Avail and/or Special
<i>A-1</i>	

LIST OF ILLUSTRATIONS

Figure		Page
• 3.2-1	Simplified Block Diagram of the OT&E FAA Redundant Configuration	7
• 3.3-1	NEXRAD And Interfaces	9

LIST OF TABLES

Table		
4.2-1	List of Test Participants On-Site	11
5.1-1	NEXRAD Service Reports Summary	15

## EXECUTIVE SUMMARY

The Weather Radar Division, ACW-200, conducted limited Phase I Operational Test and Evaluation (OT&E) Integration and OT&E Operational testing on the first Federal Aviation Administration (FAA) Offshore Next Generation Weather Radar (NEXRAD) redundant configuration in Kauai, Hawaii, from November 8 through 30, 1994.

The NEXRAD program establishes a weather network which provides accurate and suitable aviation weather products. The Joint System Program Office (JSPO) completed OT&E on the single-channel NEXRAD in 1990. The single-channel NEXRAD is currently being deployed in the Continental United States (CONUS) for use by the National Weather Service (NWS), the FAA, and Department of Defense (DOD).

The FAA has procured 14 NEXRAD systems in a redundant configuration. These systems will be deployed to non-CONUS locations in Hawaii, the Caribbean, and Alaska. All redundant configurations are currently being fielded with "Build 7" configuration software.

The redundant configuration NEXRADs were intended to be deployed as single frequency, dual-radar channel systems. However, during the development phase of these systems, interchannel leakage was discovered as a design flaw requiring a solution. A solution was implemented only to discover, at INstallation and CheckOut (INCO), that further resolution of this design problem was required. The government opted to deploy the Kauai NEXRAD as a dual-frequency, redundant configuration system. Official authorization to make FAA redundant configuration NEXRADs a dual-frequency system is still pending.

Each redundant configuration will receive a Remote Monitoring Subsystem (RMS) which will be added by FAA at a later date. Since the RMS is not yet available, OT&E was divided into two phases. Phase I covers limited OT&E Integration and OT&E Operational testing on the redundant configuration. Phase II will test the RMS subsystem in the future at a site to be determined.

Test results show that all tests passed with the exception of those tests related to Reliability, Availability, and Maintainability. These Critical Operational Issues (COI), as identified in the Test and Evaluation Master Plan (TEMP), were addressed during testing. Further COI data were collected during OT&E Shakedown testing. A complete analysis of these COIs is provided in this report.

The redundant configuration weather products were found to be equivalent to the products displayed by the single-channel NEXRAD. Inherent Availability (Ai) of the redundant configuration, including preliminary Operational Support Service (AOS) test data as of January 20, 1995, is 0.996446594 which is higher than the single-channel system, but lower than National Airspace System (NAS) requirements of 0.99987616. Some failures that occurred during testing would have

been critical failures had they failed on the single-channel system. Reliability, Availability, and Maintainability are below the NAS requirements and some suggestions to improve all of these areas are presented briefly here and in the body of this report.

Safety testing was conducted by Western Pacific Region (AWP), November 10 and November 29 through 30, 1994. AWP furnished copies of the Safety report to AND-420, AWP-450 Establishment Engineering Branch and ACW-200. The NEXRAD Technical Requirements (NTR), November 1, 1991, paragraph 3.3.6, specifies in part, that the NEXRAD system must be in compliance with Department Of Labor (DOL) Occupational Safety and Health Act (OSHA), 29 CFR 1910. Eleven of the 17 items cited as unsafe or unhealthful were violations of 29 CFR 1910.

Reliability and Maintainability could be improved by locating a Unit Control Position (UCP) and a remote Radar Data Acquisition (RDA) maintenance terminal at the Sector Field Office (SFO) supporting the NEXRAD, and by providing a means to reconfigure one of the RDA maintenance terminals at the NEXRAD site to function as a UCP. Non-redundant Pedestal Electronic Line Replacement Units (LRU) in the Digital Control Unit (DCU) should be added to the site spares list to reduce downtime. A method to provide site maintenance on a 24-hour basis (technician phone list, etc.) should be established. Reliability and Availability would also be increased by installing a Power Conditioning System (PCS), or equivalent, at the NEXRAD site on Kauai. Poor power is suspected of causing at least one critical failure that occurred during testing. Monitoring of the commercial power feed to the site indicates that it is not clean and is subject to fluctuation. OT&E testing was a limited OT&E. Offshore NEXRAD Reliability and Availability should be tracked so that further changes can be made to improve system performance.

Security testing was conducted by AWP, September 7 through 9, 1994. The Security Report presented four recommendations to improve system security. These are (1) to secure air intake ducts to prevent intrusion, (2) to modify bolts securing swing gates to the site so that bolts cannot be removed, (3) to post warning signs along the site perimeter fence line, and (4) to properly secure the power transformer box and the power disconnect switch.

## 1. INTRODUCTION.

The Next Generation Weather Radar (NEXRAD) program establishes a weather network which will provide accurate and suitable aviation weather products. The Joint System Program Office (JSPO) completed Operational Test and Evaluation (OT&E) of the single-channel NEXRAD in 1989, although Developmental Test and Evaluation (DT&E) continued through 1990. The single-channel NEXRAD system is currently being deployed in the Continental United States (CONUS) for use by the National Weather Service (NWS), the Federal Aviation Administration (FAA), and the Department of Defense (DOD).

The FAA has procured through JSPO, off-the-shelf NEXRADs in a redundant configuration (dual-radar channels) and will add a Remote Monitoring Subsystem (RMS) capability at a later date. All redundant configurations are currently being fielded with "Build 7" configuration software.

The redundant configuration NEXRADs were intended to be deployed as single frequency, dual-radar channel systems. However, during the development phase of these systems, interchannel leakage was discovered as a design flaw requiring a solution. A solution was implemented only to discover, at INstallation and CheckOut (INCO), that further resolution of this design problem was required. The government opted to deploy the Kauai NEXRAD as a dual frequency, redundant configuration system. Official authorization to make FAA redundant configuration NEXRADs a dual frequency system is still pending.

The FAA redundant configuration NEXRADs are being deployed to non-CONUS locations and hence are referred to as Offshore NEXRADs. A total of 14 Offshore NEXRADs are being procured under this acquisition: 3 in the Caribbean, 4 in Hawaii, and 7 in Alaska.

The test and evaluation concept for the Offshore NEXRAD is unique in many ways to other FAA systems. This is due to the fact that the Offshore NEXRAD is a modified version of the single-channel NEXRAD mentioned above. The single-channel NEXRADs do not comply with FAA requirements for a redundant configuration with RMS capabilities.

Since the RMS is not yet available, OT&E testing was divided into two phases. Phase I limited OT&E Integration and OT&E Operational testing was conducted in accordance with FAA Order 1810.4B and National Airspace System-System Specification, NAS-SS-1000. Testing was performed on the first FAA redundant configuration which was deployed to Kauai, Hawaii, in November 1994. Phase II testing of the RMS will be performed in the future at a site to be determined later.

This document addresses Phase I limited OT&E Integration and OT&E Operational testing of the first FAA redundant configuration NEXRAD installed in Kauai, Hawaii.

## 1.1 PURPOSE OF REPORT.

The primary purpose of this report is to provide an account of the results of the OT&E Integration and OT&E Operational testing of the Offshore NEXRAD at Kauai, Hawaii. This report also presents conclusions that were reached as a result of testing, and makes recommendations for future considerations.

## 1.2 SCOPE OF REPORT.

This report provides background information on the Offshore NEXRAD system. In addition, the report contains a description of testing and evaluation, and includes information about the test schedule and location, test participants, specialized test equipment used during testing, test objectives and criteria, test descriptions, test results, and the methods used for data collection and analysis.

The report continues with a comprehensive discussion of overall test results, including Critical Operational Issues (COI) and their resolution. Finally the report ends with test conclusions and recommendations to improve system performance.

## 2. REFERENCE DOCUMENTS.

### 2.1 FAA DOCUMENTS.

#### 2.1.1 FAA Specifications.

- |             |   |
|-------------|---|
| NAS-SS-1000 | National Airspace System (NAS) System Specification Volume I, Functional and Performance Requirements for the National Airspace System (General), October 1992.       |
| NAS-SS-1000 | NAS System Specification Volume III, Functional and Performance Requirements for the Ground-to-Air Element, February 1993.  |
| NAS-SS-1000 | NAS System Specification Volume V, Functional and Performance Requirements for the National Airspace System Maintenance and Operations Support Element, October 1992. |

#### 2.1.2 FAA Standards.

- |              |  |
|--------------|--|
| FAA-STD-024B | Content and Format Requirements for the Preparation of Test & Evaluation Documentation, August 22, 1994. |
| CT 1710.2B   | Preparation and Issuance of Formal Reports, Technical Notes and other Documentation, February 13, 1990.  |

### 2.1.3 Other FAA Publications.

FAA ORDER 1810.1F FAA Acquisition Process, March 19, 1993.

FAA ORDER 1810.4B FAA NAS Test and Evaluation Policy, October 22, 1992.

TECHNICAL NOTE CT-TN93/36 FAA Next Generation Weather Radar (NEXRAD) Principal User Processor (PUP) OT&E Operational Report October 1993

TEMP NEXRAD Test and Evaluation Master Plan (TEMP), Addendum For The Offshore NEXRAD, August 1994.

TEST PLAN FAA Offshore NEXRAD OT&E Integration and OT&E Operational Test Plan, August 1994.

TEST PROCEDURES FAA Offshore NEXRAD OT&E Integration and OT&E Operational Test Procedures, August 1994.

QUICKLOOK REPORT FAA Offshore NEXRAD OT&E Integration and OT&E Operational Quicklook Report, December 1994.

### 2.2 OTHER DOCUMENTS.

Doviak, R. J., and D. S. Zrnić, 1984: Doppler Radar and Weather Observations, Academic Press, Orlando.

29 CFR 1910 Department Of Labor (DOL), Occupational Safety and Health Act (OSHA)

JSPO R400-TP301 Next Generation Weather Radar Test and Evaluation Master Plan, May 31, 1990.

R400-SP401A NEXRAD Technical Requirements (NTR), November 1, 1991.

AFOTEC PROJECT 86-0167 NEXRAD Initial Operational Test and Evaluation, Phase II Final Report, December 1989.

MIL-HDBK-781 Military Handbook, Reliability Test Methods, Plans, and Environments for Engineering Development, Qualification, and Production, July 14, 1987.

### 2.3 UNISYS DOCUMENTS.

CDRL 505 Critical Item (CI) Level Test Procedures for Redundancy, May 20, 1993.

1310035A Build 7 Test Plan, October 15, 1993.

CDRL 245 Build 7 Test Procedures, November 1, 1993.

DV1208251F CI Development Specification for Tower Utilities (B4, CI-01).

DV1208252G CI Development Specification for Antenna Pedestal (B2, CI-02).

DV1208253F CI Development Specification for Transmitter (B2, CI-03)

DV1208254E CI Development Specification for Receiver/Signal Processor (B2, CI-04).

DV1208255F CI Development Specification for Radar Data Acquisition (RDA) Control (B2, CI-05).

DV1208256E CI Development Specification for Wideband Communications Link (B2, CI-06).

DV1208257F CI Development Specification for Radar Product Generation (RPG) Equipment (B1, CI-07).

DV1208258F CI Development Specification for Principal User Processor/RPG Operational Position (PUP/RPGOP) Equipment (B1, CI-08).

DV1208250E CI Development Specification for RDA Equipment (B1, CI-09).

CDRL 246 Production Acceptance Tests For CLIN 0001AD, Bloomfield, Connecticut.

### 3. SYSTEM DESCRIPTION.

#### 3.1 MISSION REVIEW.

The NEXRAD mission is to provide improved aviation safety and more efficient use of airspace through the detection and warning of hazardous weather in the enroute and oceanic environments. The Offshore NEXRADs will acquire, process, distribute, and display weather radar information. This information includes location, severity, and movement of both routine and hazardous weather phenomena.

These Offshore NEXRADs must fully meet users' requirements for timely, reliable, and operationally acceptable hazardous weather and planning information. The system must be supportable, cost effective, growth adaptable, and be acquired in accordance with applicable standards, regulations, and policies.

The FAA will maintain Offshore NEXRADs in areas where neither the Department of Commerce (DOC) nor the DOD provide coverage, such as Alaska, Hawaii, and the Caribbean. The NWS will operate these units to provide weather information to Air Traffic Control (ATC) facilities, the aviation community, and other principal users.

The FAA Offshore NEXRAD is being fielded with a redundant channel to increase system availability. Either radar channel has complete NEXRAD weather detection capability. In the future, all Offshore NEXRADs will be equipped with an RMS when this interface becomes available.

#### 3.2 TEST SYSTEM CONFIGURATION.

The Offshore NEXRADs will acquire, process, distribute, and display weather radar information to support the NWS, FAA, and DOD. Offshore NEXRADs, like CONUS NEXRADs, require a trained meteorologist to interpret NEXRAD data. Therefore, the Offshore NEXRAD system operators will be NWS personnel at selected Weather Forecast Offices (WFO) and the system maintainers will be FAA personnel.

Phase I limited OT&E Integration and OT&E Operational testing was performed in November 1994, on the redundant NEXRAD site located in Kauai, Hawaii, and is described herein. Testing was limited in nature due to the extensive testing already performed on the single-channel NEXRAD system by the JSPO and funding constraints placed upon the FAA.

Figure 3.2-1 is a simplified block diagram of the Offshore NEXRAD system that underwent OT&E testing. The left side shows the redundant configuration site located in Kauai. Notice that the redundant configuration gives the Offshore NEXRAD the capability to switch between either channel where each channel has a dedicated RDA and RPG. The right side of figure 3.2-1 displays the dual Unit Control Position (UCP) configuration. As mentioned above, the NWS will operate Offshore NEXRADs and FAA will maintain them. This situation requires use of a dual UCP configuration. The NWS controls the system for normal operation (such as changing scan strategies, etc.) at selected WFOs via a remote UCP. When system maintenance is required, the FAA will take control of the system at the Center Radar Approach Control (CERAP) or Air Route Traffic Control Center (ARTCC), via an A/B data switch and another UCP. Limited Phase I OT&E Integration and OT&E Operational testing included the UCP located at the Honolulu NWS WFO.

Key operation and maintenance positions for Phase I OT&E testing included the PUP, UCP, and the RDA maintenance terminals. The PUP was not included as part of limited Phase I OT&E testing. A full OT&E operational evaluation of the PUP was completed in April 1993, at the ARTCCs in Leesburg, Virginia, and Houston, Texas. A NEXRAD PUP OT&E Operational Report was published as a Technical Note in October 1993.

Although the redundant configuration was intended to be deployed as a dual-channel single frequency system, interchannel leakage was discovered as a design flaw during the development phase. A solution was implemented; however during INCO, it was discovered that additional measures were required. The government decided to deploy the Kauai NEXRAD system with a separate frequency for each radar channel (2760 MegaHertz (MHz), Channel 1; 2770 MHz, Channel 2). Official authorization to field all redundant configurations with dual frequencies is still pending. All redundant configurations are currently being fielded with "Build 7" software.

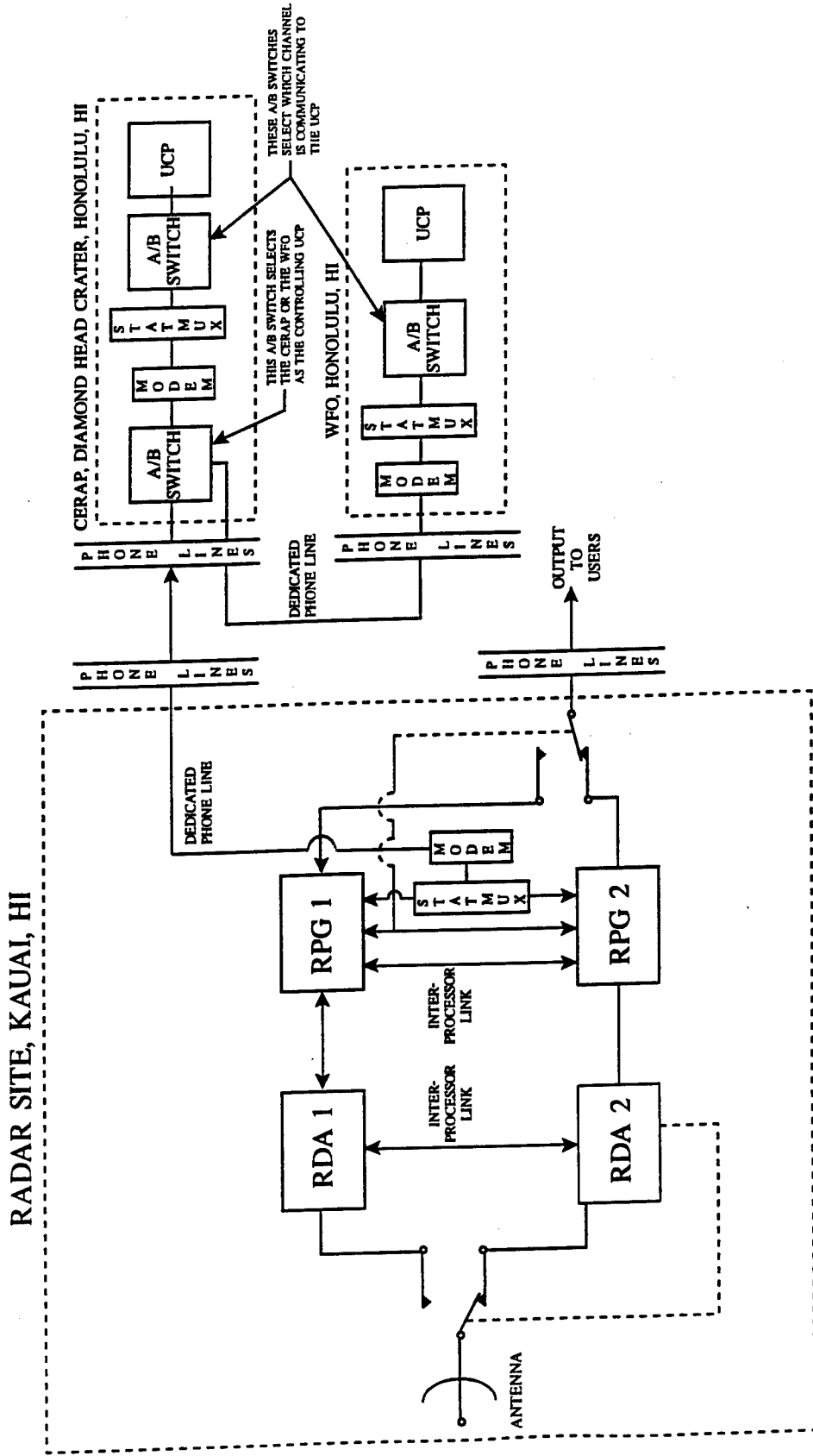

FIGURE 32-1. SIMPLIFIED BLOCK DIAGRAM OF THE OT&E FAA REDUNDANT CONFIGURATION

### 3.3 INTERFACES.

The Offshore NEXRAD was initially deployed and tested as a stand-alone system. It does have the capability to work with various interfaces as they become available. As shown in figure 3.3-1, the Offshore NEXRAD system will interface with the Weather And Radar Processor (WARP), non-FAA users, vendors, the Maintenance Processor Subsystem (MPS) and Maintenance Data Terminal (MDT).

a. NEXRAD/WARP. Digitized base products and selected derived products will be forwarded to the WARP, routinely and upon request, for analysis and annotation by the NWS meteorologist at the Central Weather Service Unit (CWSU). The WARP will automatically mosaic and contour NEXRAD data in image format for distribution.

b. NEXRAD/Non-FAA Users. The digitized base data will be made available to the National Oceanic and Atmospheric Administration (NOAA) and DOD, as required.

c. NEXRAD/Vendor. The digitized base data will be made available to selected commercial vendors which provide weather services to the FAA.

d. NEXRAD/MPS. The NEXRAD/MPS interface provides the transfer of requests for, and reports of, status data, performance data, diagnostics data, and maintenance control commands between the MPS and the NEXRAD via a standard interface.

e. NEXRAD/MDT. The NEXRAD will have a communication port to interface with an MDT. The NEXRAD will process maintenance control commands between the MPS and the NEXRAD via a standard interface. The NEXRAD will process maintenance control commands from the MDT and will provide status, performance data, and diagnostics data to the MDT when requested by an operator at the MDT. The NEXRAD will route terminal messages exchanged between the MPS and the MDT.

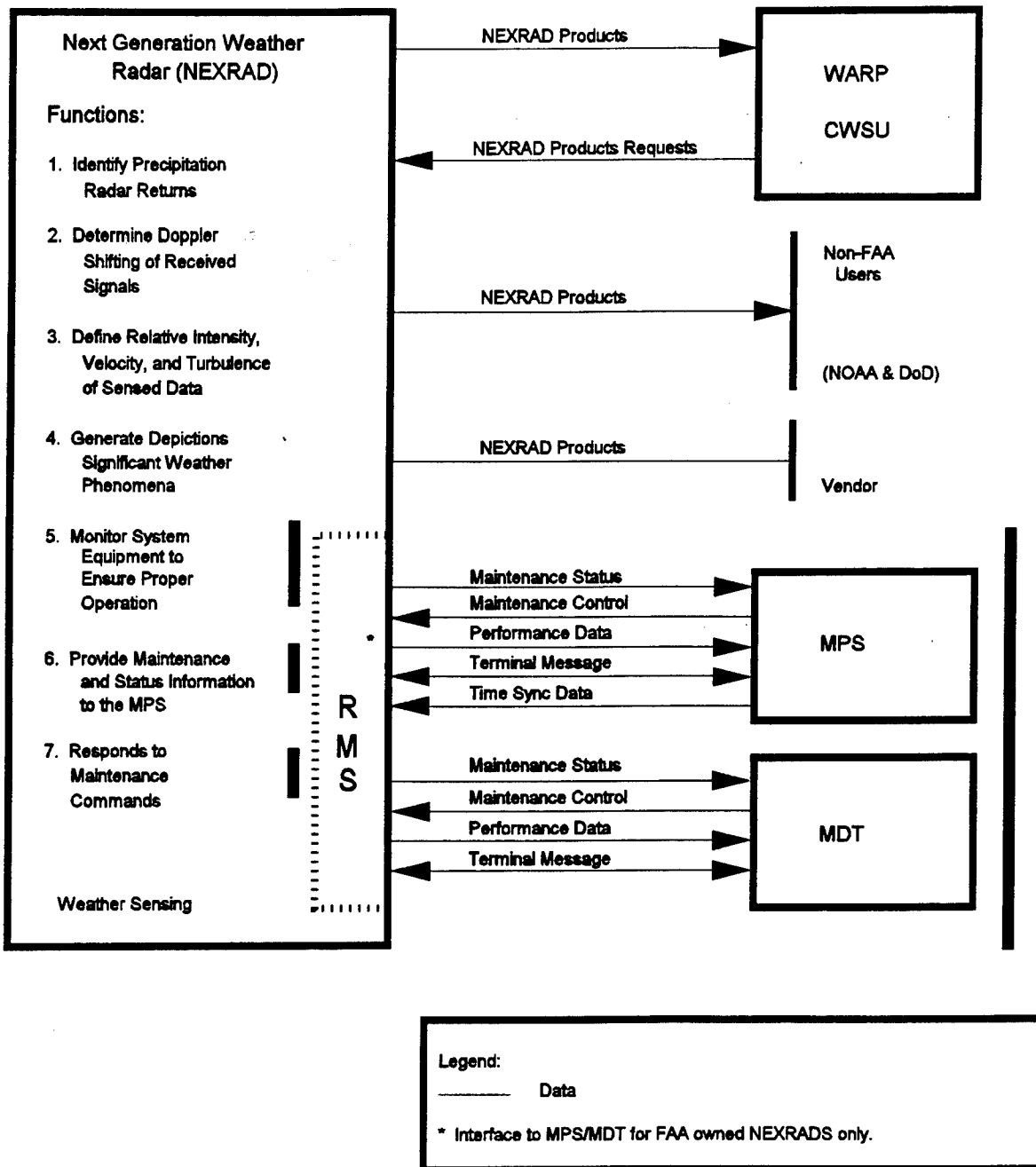

FIGURE 3.3-1. NEXRAD AND INTERFACES

#### 4. TEST AND EVALUATION DESCRIPTION.

Appendix A is a summary list of test procedures, test objectives/criteria, test descriptions, data collection and analysis information, test results, and other pertinent test data (such as test connected service reports and COI information) for each of the individual tests conducted.

##### 4.1 TEST SCHEDULE AND LOCATIONS.

OT&E Integration and OT&E Operational testing took place at the first Offshore NEXRAD system which was deployed to the island of Kauai, Hawaii. OT&E Security testing occurred September 7 through 9, 1994; OT&E Safety testing, November 10, 1994 and November 29 through 30, 1994; the remainder of OT&E testing was from November 8 through 30, 1994.

Testing took place at two sites: The NWS WFO in Honolulu, where the UCP and PUP are located, and the NEXRAD site itself, located in Kauai.

4.2 PARTICIPANTS.

Table 4.2-1, lists organizations and functions of on-site test participants.

TABLE 4.2-1. LIST OF TEST PARTICIPANTS ON-SITE

Organization	Function
ACW-200	Associate Program Manager For Test (APMT) Test Director Assistant Test Director
Alaskan Region (AAL), Fairbanks Radar AAL, Kenai Sector Field Office (SFO)	Systems Specialist Systems Specialist
Western Pacific Region AWP-464.10S AWP-483 Civil Aviation Security Division AWP-700 HIP Sector	Safety Test Radiation-Hazard Test Security Test 2 Systems Specialists
NWS, Weather Forecast Office	2 Meteorologists/Evaluators
JSPO	Test Observer
Southern Region (ASO)	Assistant Test Director

In addition to the above, three individuals from ACW-200 provided test support from the FAA Technical Center.

#### 4.3 TEST AND SPECIALIZED EQUIPMENT.

Along with the standard NEXRAD equipment list for operation and maintenance, the following electronic equipment or equivalent, were used to perform Phase I OT&E Integration and OT&E Operational testing:

- a. Oscilloscope
- b. Power Meter HP 438
- c. Power Sensors HP 8481A and 8481D
- d. Connectors (RF and Data) HP-IB, Type N, BNC, TNC, Triax
- e. Spectrum Analyzer HP 8569B
- f. High Voltage Probe
- g. Variable Attenuators
- h. Frequency Counters HP 5361B (Microwave Pulse)
- i. Synthesizer HP 8673E-B
- j. Coaxial Detector HP 423B
- k. Color Plotter HP 7090
- l. Pulse Generator
- m. Personal Computer

ACW-200 developed a reliability and availability software program to track the Mean Time Between Failure (MTBF), Mean Time Between Critical Failure (MTBCF), Mean Time To Repair (MTTR), and Inherent Availability (Ai) during the Phase I test interval. The Test Director managed the input of failure data by the test team.

#### 4.4 TEST OBJECTIVES/CRITERIA.

As identified in the ACW OT&E Integration and OT&E Operational Test Plan, the following objectives were accomplished during testing:

- a. Verified conformance to the single-channel NEXRAD system including weather product verification compared to an operational single-channel system.
- b. Verified performance of the FAA redundant configuration features including switching of channels, performance of redundant specific items and simultaneous operation of channels.
- c. Tested the redundant configuration per 1810.4B including Reliability, Maintainability, Availability, Degraded Operations, Safety, Security, Site Adaptation Data and the NAS-SS-1000 criteria from appendix B of the Test Plan.

Individual Test Objective/Evaluation Criteria for each of the tests conducted are listed in appendix A.

#### 4.5 TESTING DESCRIPTIONS.

Test descriptions for each of the tests conducted are listed in appendix A.

#### 4.6 DATA COLLECTION AND ANALYSIS METHOD.

Data collection and analysis methods for each of the tests conducted are listed in appendix A.

#### 5. RESULTS AND DISCUSSION.

The OT&E testing performed by ACW lasted from November 8 through 30, 1994. In this 22-day period, ACW conducted 34 tests and generated 27 Service Reports to complete testing 2 weeks ahead of schedule. During the test interval, 2 critical failures and 11 noncritical failures occurred.

Several factors contributed to a successful test effort. Primary factors include the high degree of motivation and skill demonstrated by the AAL and AWP technicians, the cooperation from the AWP sector in Hawaii, AOS, and the cooperation and expertise of the NWS WFO in Honolulu at evaluating NEXRAD products. Other factors such as the support of the Operational Support Facility (OSF), the Acceptance Representative from JSPO, the NEXRAD Redundancy training prior to OT&E testing, and the availability of the Molokai (single channel) NEXRAD contributed significantly to OT&E testing.

The Kauai NEXRAD had a higher than normal amount of total operating hours at the start of OT&E testing. This was due to the Amplitude Modulation (AM) station interference and interchannel leakage problems which had to be resolved prior to government acceptance of the system. This had a positive effect on our testing since it allowed us to test a more mature system during our test period. Prior to the start of testing at Kauai, the ACW test team was given information about site specific anomalies and other anomalies common to NEXRAD systems. The anomalies and their effect on the operational performance of the system are documented throughout OT&E testing.

Only two shortfalls can be noted from testing. First, the test team was unable to coordinate any testing with the CERAP in Honolulu because, they do not have trained personnel to perform NEXRAD operation or maintenance. Second, the test team was unable to determine the cause of the critical failure in which both RPGs failed. The cause of this failure is still under investigation. Test data has been forwarded to JSPO.

The FAA Offshore NEXRAD has some beneficial features which became evident during testing. Excellent self-diagnostic capabilities, although hindered by anomalies, make the system easier to troubleshoot and repair. Support from the OSF gives the maintainer a 24-hour Hotline to call for assistance.

Test results for system performance were satisfactory in all areas except, Reliability, Availability, Maintainability, Safety, and Security.

A brief summary of the results for each specific test is provided in appendix A. Data have been collected to substantiate the test results. These data are in the form of color weather plots, Service Reports, Test Comments/Notes Sheets, Test Data Sheets, a Maintainability Questionnaire, system status logs, the test log book, and various raw data plots. These data are on file at the FAA Technical Center, Atlantic City International Airport, NJ.

### 5.1 SERVICE REPORTS.

Table 5.1-1 is a summary of Service Reports which resulted from testing. Some Service Reports identify deficiencies and/or failures while other Service Reports merely provide information concerning incidental conditions during testing. The summary of Service Reports details various information including the priority of the Service Report and recommendations to bring the Service Report to closure. Definitions for prioritizing the Service Reports in the summary are provided below.

I - CRITICAL: A problem that prevents or stops the system from performing its mission and/or jeopardizes personnel safety.

II - MAJOR: A problem that adversely affects the operational capability and effectiveness of the system so as to degrade performance or availability and require significant and/or recurring action to repair.

III - MINOR: A problem that adversely affects the accomplishment of an operation or essential capability of the system so as to require a repair action.

IV - OTHER: A problem, repair of a problem, or information about a problem that occurred during testing. No action is required for closure.

Where applicable, recommendations to resolve the Service Report have been provided. Specific recommendation numbers referenced in the Service Reports summary are defined in section 7. Per the Offshore NEXRAD TEMP, ACW-200 will track the resolution and closure of these Service Reports.

TABLE 5.1-1. NEXRAD SERVICE REPORTS SUMMARY

SR #	Priority	Nature of Report	Service call req.	Site visit req.	Site visit w/REM RDA TERM & UCP	Anomaly	Critical Failure	Non-Critical Failure	Recurring or Related Failure	Mean Time to Repair (MTTR)	Recommended Action Required for Closure
1.	II	Log Channel Klystron test signal degraded	Y	Y	N	✓		✓	✓	5 Min	Yes (#5)
2.	II	Loss of Commercial Power with engine generator in auto Fan Failure (FF)	Y	Y	N			✓	✓FF	5 Min	Yes (#s1,2,6)
3.	II	Linear test signal degraded	Y	N	N	✓			✓	3 Min	Yes (#5)
4.	II	RPG link initial failure	Y	Y	N			✓	✓FF	5 Min	Yes (#1,2,6)
5.	III	Filters	N/A	N/A	N/A						None - Check filters or clean boards during routine maint.
6.	III	Cable Trough	N/A	N/A	N/A						Yes - Fix trough to floor per install instructions.
7.	I	VME failure	Y	Y	Y		?	?		45 Min	Yes (#1,2,4,6)
8.	I	RDA terminal lockup w/VME failure	Y	Y	Y		?	?		2 Min	Yes (#1,2,4,6)
9.	IV	On-line storage overload	N/A	N/A	N/A						None required
10.	I	VME Failure	Y	N	N		?	?		5 Min	Yes (#s1,2,4,6)
11.	I	VME & Micro 5 failure (Ch #1)	Y	Y	Y		?	?			Yes (#1,2,4,6)
12.	II	Multiple Fan Failure	Y	Y	N			✓	✓FF	10 Min	Yes (#s1,2,6)
13.	II	RDA control failure	Y	Y	N	✓		✓	✓	5 Min	Yes (#5)
14.	III	Modem reset	Y	N	N			✓		30 Min	Yes (#6)
15.	II	Multiple Fan Failure	Y	Y	N			✓	✓FF	10 Min	Yes (#s1,2,6)
16.	II	D-2 Failure (incl. Fan Failure)	Y	Y	N			✓	✓	20 Min	Yes (#5)

SR #	Priority	Nature of Report	Service call req.	Site visit req.	Site visit w/REM RDA TERM & UCP	Anomaly	Critical Failure	Non-Critical Failure	Recurring or Related Failure	Mean Time to Repair (MTTR)	Recommended Action Required for Closure
17.	II	Temp Floyd	Y	Y	N	✓		✓	✓	3 Min	Yes (#5)
18.	II	XMTR post chg. regulator	Y	N	N	✓		✓	✓	3 Min	Yes (#5,6)
19.	III	Phone Inaudible	N/A	N/A	N/A						Yes - Install phone amplifier or headset
20.	II	Fan Failure	Y	Y	N			✓	✓/FF	30 Min	Yes (#s1,2,6)
21.	II	8 hr. cal alarm	Y	Y	N	✓		✓	✓	5 Min	Yes (#5)
22.	IV	Waveguide Press	N/A	N/A	N/A						None required
23.	II	XMTR post chg. regulator	Y	N	N	✓		✓	✓	3 Min	Yes (#5)
24.	II	S/W error	Y	N	N	✓		✓	✓	30 Min	Yes (#5)
25.	IV	Interchannel leakage	N/A	N/A	N/A						None required
26.	I	Power supply in Ped Elec.	Y	Y	Y		✓			2 Hours	Yes (#1,2,3)
27.	IV	XMTR post chg. regulator	Y	Y	Y			✓	✓	30 Min + Time to Replace	None required

Notes:

1. Refer to section 7. Recommendations for corresponding recommendation numbers, definition and justification.
2. SR #s 2, 4, 12, 15 and 20 are related failures.
3. SR #s 7, 8, 10 and 11 are related failures with unknown cause and failure sequence.

## 5.2 CRITICAL OPERATIONAL ISSUES.

Reliability, Maintainability, and Availability of the Offshore NEXRAD system are Phase I COIs. As defined in the Offshore NEXRAD TEMP, the testing at Kauai was to address three Measure Of Suitability (MOS)s. Based on this limited OT&E testing at Kauai, the following answers to these Phase I COIs in the TEMP are provided:

**COI A. Is the Reliability, Maintainability, and Availability of the Offshore NEXRAD system suitable for incorporation into the NAS when used in an operational environment with the available FAA resources, logistics plan, personnel, and system maintenance procedures?**

Our testing indicates that the performance of the Offshore NEXRAD System is as follows:

The MTBF of the Kauai Offshore NEXRAD is 209 hours. Per MIL-HDBK-781, we have a 95 percent confidence level that the MTBF of the system is between 116 hours and 484 hours.

The availability of the Kauai Offshore NEXRAD is 0.95739808, (i.e., the system is available 95.7398 percent of the time) when used in an operational environment, including support and logistics.

The MTTR of the Kauai Offshore NEXRAD, including support and logistics, is 9.3 hours when used in the operational environment at Kauai, Hawaii.

The recommendations listed in section 7 identify required action for improvement in these areas. If the recommendations listed in section 7 are implemented, required maintenance resources will cost effectively be reduced.

**COI MOS A-1. Will the FAA redundant configuration NEXRAD perform at the level of reliability and availability required by the NAS? The Availability requirement is 0.99987616 and the MTBF requirement is 4037 hours.**

The FAA redundant configuration will not perform at the level of reliability and availability required by the NAS-SS-1000. Our test data, including preliminary test data from AOS shakedown testing as of January 20, 1995, indicate an actual system Ai of 0.99644659 (i.e., the system is available 99.6446 percent of the time) and an actual MTBF of 209 hours. Improvements in these areas will be required if the system is to meet NAS-SS-1000 specification. Following the recommendations listed in section 7 will provide immediate improvements in reliability and availability. Ongoing work by the OSF will provide long-term continuous improvement in these areas and will greatly contribute to the rate at which the system matures.

**COI MOS A-2. Have FAA maintenance personnel received a system capable of performing at the level of maintainability required by the NAS, and have they received the resources necessary to maintain it to this requirement? The MTTR requirement is 0.5 hours.**

The FAA redundant configuration will not perform at the level of maintainability required by the NAS-SS-1000. Our test data, including preliminary test data from AOS shakedown testing as of January 20, 1995, indicate an actual MTTR of 0.74 hours. The NAS-SS-1000 figure may be achieved by following the recommendations listed in section 7. In the long term, corrective maintenance procedures will mature via additional revisions based on experience. The proper corrections will be made to the system and the maintenance manuals that will make corrective maintenance more efficient. The OSF is the primary organization responsible for this effort. Finally, as FAA maintenance personnel receive greater system experience, corrective maintenance procedures will become more familiar and they will advance up the learning curve for the Offshore NEXRAD system.

**COI MOS A-3. Operationally will there be sufficient FAA personnel assigned to maintain the Offshore NEXRAD system? The Availability requirement is 0.99987616.**

At the time of this writing, we do not have the FAA maintenance personnel requirement specifications for the FAA Offshore NEXRAD system. Resources in terms of maintenance personnel and advances in system performance, will be required for the Offshore NEXRAD system to perform to the NAS-SS-1000 specification for reliability, maintainability, and availability. The recommendations in section 7 define the beginnings of advancement toward the NAS-SS-1000 specification. If the recommendations in section 7 are followed, FAA maintenance personnel will have the resources required to work effectively and efficiently.

Analysis of the test data indicate that the system needs to perform better in the areas of Reliability, Maintainability, and Availability. The NEXRAD system has self-diagnostics as well as the OSF which provides a 24-hour Hotline for troubleshooting and support. Recommendations are provided to improve Reliability, Maintainability, and Availability of the system based on the limited OT&E testing that was done at Kauai. The final recommendation calls for further tracking of maintenance actions and analysis of failure data in order to make further advancements in these areas. All of the recommendations are necessary if the Offshore NEXRAD system is to perform to NAS-SS-1000 specification.

### 5.3 RETESTING.

No Phase I testing was deferred. All Phase I tests have been completed and although the results show that some improvements need to be made, no retesting is anticipated at this time.

### 6. CONCLUSIONS.

All tests passed except for safety and security, and those that related to reliability, maintainability and availability which have been identified as Critical Operational Issues (COI) in the Test and Evaluation Master Plan (TEMP). The system has several safety violations that have been identified from the Western Pacific Region (AWP) safety inspection. These violations must be corrected to bring the system in conformance with Federal Aviation Administration (FAA) safety standards. Radiation Hazard measurements taken on the Next Generation Weather Radar (NEXRAD) system as part of safety testing by AWP, showed the system to be safe. Recommendations to improve system security issued by AWP are listed in section 7. No Phase I regression testing or retesting is anticipated at this time.

The Offshore NEXRAD system is a sophisticated, dual-channel doppler weather radar. Prior to the start of OT&E testing, a familiarization course in the contractors design of a redundant NEXRAD configuration was provided for the test team. This redundancy training was very useful and allowed the entire test team to perform effectively throughout the test interval.

The specific results of the testing are provided, with explanations, in the recommendations in section 7. These recommendations focus on improving reliability, maintainability, availability, safety and security. The results of test data indicate that there are several practical, cost effective measures that can be made to improve system performance in these areas.

### 7. RECOMMENDATIONS.

Based on an analysis of Operational Test and Evaluation (OT&E) test data, the following is a list of recommendations to improve Reliability, Maintainability, Availability, Security, and Safety:

Recommendation #1) A Unit Control Position (UCP) terminal (or capability) is required at the radar site.

Basis for recommendation: When a failure occurs, the technician needs to know what failed in order to repair it. The UCP terminal is the only device which can access the system status log to determine what happened to the system prior to and during the failure. This information is required by the technician for every failure that occurs as well as determining when a system anomaly

occurs that does not require corrective maintenance. As an example, troubleshooting at Kauai was a very time-consuming process when a failure occurred on site because the technician had to walk through the system status log with the operator at the Weather Forecast Office (WFO) over the phone. It is a very tedious process for a maintainer to try to tell an operator what to look for prior to a system failure. Troubleshooting a critical failure was impossible to do using this method. For the technician to troubleshoot the problem, the WFO had to fax 198 pages (99 pages each channel) of the system status log to the Sector Field Office (SFO) in Kauai. Then the technician had to drive from the site to the SFO to pick up the fax, then drive back to the site to fix the failure. Troubleshooting and repair would be greatly reduced if the technician had access to a Unit Control Position (UCP) terminal or the capability to use a Radar Data Acquisition (RDA) maintenance terminal like a UCP terminal.

Recommendation #2) A method to provide maintenance to a site on a 24-hour basis (technician phone list, etc.) should be established.

Basis for recommendation: When a failure occurs in a non-redundant area of the system, the system is off-the-air and remains inoperative until corrective maintenance can be performed. This scenario occurred during testing and reduced availability. When a failure occurs in a redundant area of the system and the operator switches to the redundant channel, the system is now in a state of reduced availability (i.e., equivalent to a single-channel system availability). It is now more likely that a complete system shutdown will occur without immediate corrective maintenance action. One critical failure occurred during a weekend when the Radar Product Generator (RPG) failed and the second RPG failed less than 2 days later. Since no maintenance was performed after the first failure, the system went off-the-air when the second RPG failed. The increase in availability from a redundant configuration comes with a price and that price is an increase in required (corrective and preventive) maintenance. If the maintenance is not performed as quickly as possible, such as using a 24-hour contact list for repair, then the benefit of increased availability provided by the redundant configuration is not fully realized.

Recommendation #3) Non-Redundant Pedestal Electronics Line Replaceable Units (LRU) in the Digital Control Unit (DCU) should be added to the site spares list to reduce downtime.

Basis for recommendation: A critical failure occurred in a power supply in the pedestal electronics area which is a non-redundant area of the system. The system was off-the-air for about 2 days because of a 15-volt power supply. These LRUs should be added to the site spares list in order to reduce downtime.

Recommendation #4) Power conditioning equipment should be provided in order to increase system reliability.

Basis for recommendation: One of the critical failures as well as several noncritical failures are linked to the intermittent utility power at Kauai. The island of Kauai runs on an electrical generator. A power monitor was connected to the site at the beginning of testing and indicated several spikes and power interruptions during the test period. Power conditioning equipment would increase reliability and availability by eliminating system problems associated with utility power.

Recommendation #5) The UCP and RDA maintenance terminal should be remoted to the SFO (or its equivalent) in order to reduce site visits.

Basis for recommendation: The test data indicate that out of the 15 service reports that would have required a site visit to perform corrective maintenance actions, only 5 site visits would have been necessary if the trained technician had a remote RDA maintenance terminal at the SFO. Also, remoting the RDA maintenance terminal with the UCP terminal is the most cost effective measure to reduce the required number of site visits by at least two-thirds.

Recommendation #6) The OT&E testing performed by ACW-200 was a LIMITED OT&E Test. FAA Offshore Next Generation Weather Radar (NEXRAD) failures as well as Reliability and Availability data should be tracked in order to make further changes to improve the system performance.

Basis for recommendation: The testing was limited in nature. To make further recommendations that will increase the Reliability, Maintainability and Availability of the system, more failure data of the FAA Offshore NEXRAD is necessary. This would require further tracking and analysis in order to identify and implement measures that will bring the system up to NAS-SS-1000 specifications.

Security Recommendation: To bring the Offshore NEXRAD up to FAA security standards, the following items need to be corrected:

Air intake ducts used for refrigeration systems are large enough to permit potential intrusion. To prevent intrusion, an effective barrier consisting of the use of steel bars set into a sturdy frame affixed to the duct wall will provide the needed safeguard. The bolts used to secure the fence line swing gates must be peened or otherwise modified in such a manner that will preclude their unauthorized removal.

The power utility box containing the power transformer for the site, and the power disconnect switch both must be properly secured.

Finally, FAA warning signs identifying the facility as being important to air safety and warning against trespassing or attempting to damage the facility must be affixed to the perimeter fence.

Basis for recommendation: As part of OT&E testing, AWP conducted a Physical Security Survey and Threat/Vulnerability/Risk Assessment of the Kauai NEXRAD. Testing took place September 7 through 9, 1994. The Summary of Findings listed the four items above as requiring corrective action.

Safety Recommendation: To bring the Offshore NEXRAD up to FAA safety standards, it is necessary to correct the 17 unsafe or unhealthful conditions listed in the appendix under D-9, Safety Test Results. In addition, a recommendation was made to install emergency lighting in the tower dome, electronic equipment room, and engine generator room. Also, it was suggested that a decision be made regarding disposition of the halon discharge unit and associated fire suppression switches in the electronic equipment room.

Basis for recommendation: As part of OT&E Operational testing, AWP conducted a comprehensive safety inspection of the Kauai NEXRAD. The inspection lists 17 items on Occupational Safety and Health Inspection Report (FAA Form 3900-1), that require correction to bring the NEXRAD system into compliance with FAA safety standards. Two additional recommendations are suggested that would improve NEXRAD safety.

## 8. ACRONYMS AND ABBREVIATIONS.

AAL	Alaskan Region
ACW-200	Weather Radar Division
Ai	Inherent Availability
AM	Amplitude Modulation
ANSI	American National Standards Institute
AOS	Operational Support Service
APMT	Associate Program Manager For Test
ARTCC	Air Route Traffic Control Center
ASO	Southern Region
ATC	Air Traffic Control
AWP	Western Pacific Region
CERAP	Center Enroute Radar Approach Control
CI	Critical Item
COI	Critical Operational Issue
CONUS	Continental United States
CW	Continuous Wave
CWSU	Central Weather Service Unit
dB	Decibel
dBz	Radar Reflectivity Factor
DCU	Digital Control Unit
DOC	Department Of Commerce
DOD	Department Of Defense
DOL	Department Of Labor
DT&E	Development Test and Evaluation
FAA	Federal Aviation Administration
FAT	Factory Acceptance Test
GHZ	GigaHertz
HIP	Hawaii-Pacific Sector
INCO	INstallation and CheckOut
JSPO	Joint System Program Office
kcmil	thousand circular mils
km	kilometer
LRU	Line Replaceable Unit

MDT	Maintenance Data Terminal
MHz	MegaHertz
MOS	Measure Of Suitability
MPS	Maintenance Processor Subsystem
MTBCF	Mean Time Between Critical Failure
MTBF	Mean Time Between Failure
MTTR	Mean Time To Repair
N/A	Not Applicable
NAS	National Airspace System
NAS-SS	National Airspace System-System Specification
NEC	National Electric Code
NEXRAD	Next Generation Weather Radar
NOAA	National Oceanic and Atmospheric Administration
NTR	NEXRAD Technical Requirements
NWS	National Weather Service
OSHA	Occupational Safety and Health Act
OT&E	Operational Test and Evaluation
PCS	Power Conditioning System
PUP	Principal User Processor
RDA	Radar Data Acquisition
RDASOT	Radar Data Acquisition System Operational Test
RF	Radio Frequency
RMS	Remote Monitoring Subsystem
RPG	Radar Product Generator
RPGOP	Radar Product Generator Operating Position
RPS	Routine Product Set
SFO	Sector Field Office
SNR	Signal-to-Noise Ratio
TEMP	Test and Evaluation Master Plan
UCP	Unit Control Position
UTC	Universal Time Coordinated
VCP	Volume Coverage Pattern
WARP	Weather And Radar Processor
WFO	Weather Forecast Office

APPENDIX A  
LIST OF TEST PROCEDURES, OBJECTIVES, DESCRIPTIONS, TEST ANALYSIS  
METHODS AND TEST RESULTS<sup>1</sup>

---

<sup>1</sup> NOTE - Test Comment/Notes and Service Reports are available upon request from ACW-200 Weather Radar Division; FAA Technical Center; Atlantic City Int'l Airport, New Jersey 08405

**Test:** D-1, Weather Base Product Verification Test

**Test Objective/  
Evaluation Criteria:** Verify that each channel of the Federal Aviation Administration (FAA) redundant configuration provides weather base products that are meteorologically equivalent to an actual baseline of weather data.

**Test Description:** A National Weather Service (NWS) meteorologist tested weather base products produced by each channel, under various operational modes and conditions. Comparison was made against a baseline of actual weather data.

**Data Collection and  
Analysis Method:** ACW-200 (Weather Radar Division) and NWS used the Kauai and Molokai NEXRAD Principal User Processor (PUP) graphics tablets to request base data. Kauai and Molokai Next Generation Weather Radar (NEXRAD) PUP plots were collected and compared.

**Test Results:** ACW-200 and NWS successfully verified that each channel's base data (base reflectivity, base velocity, spectrum width, and composite reflectivity) were comparable to an actual baseline of weather data (Molokai NEXRAD data). Refer to figures A-1 and A-2.

**Service Reports  
Generated:** None

**COIs Addressed:** N/A

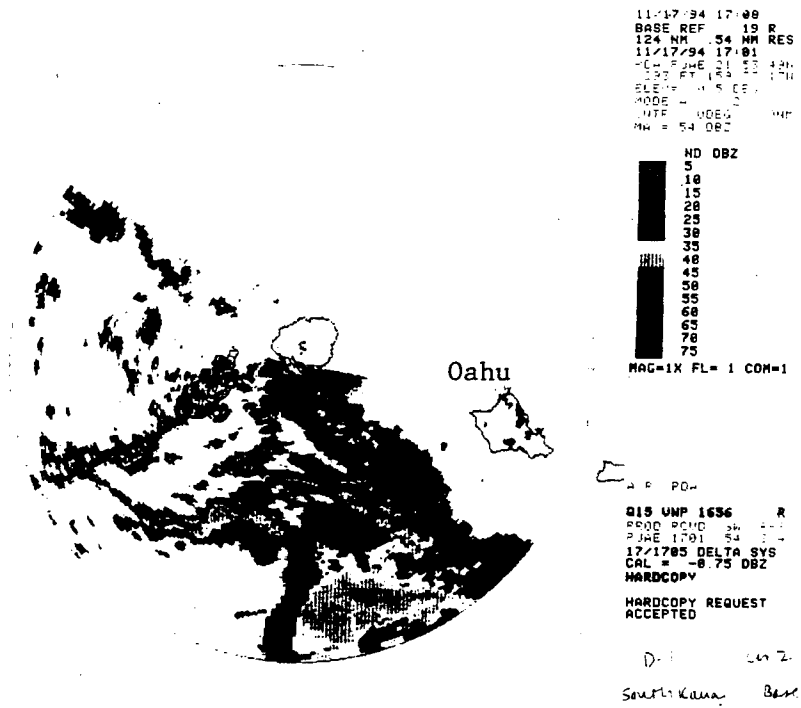

SYDRP ID	19					
BY	BDN	234	182			
EST	ADJ	130	11.2			
TRK	ERR	1.2	1.2			
DBZH	RCI	15.5	13.8			

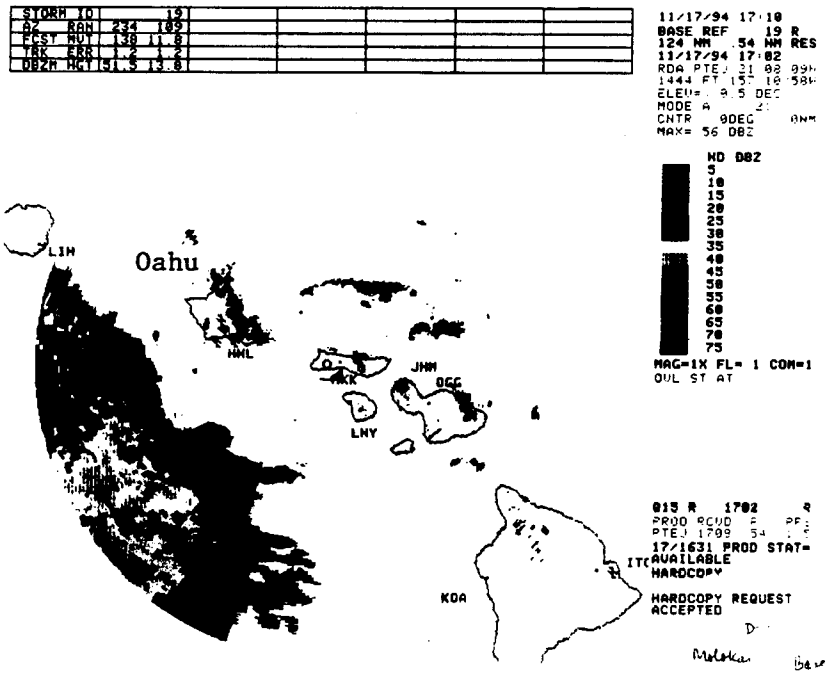
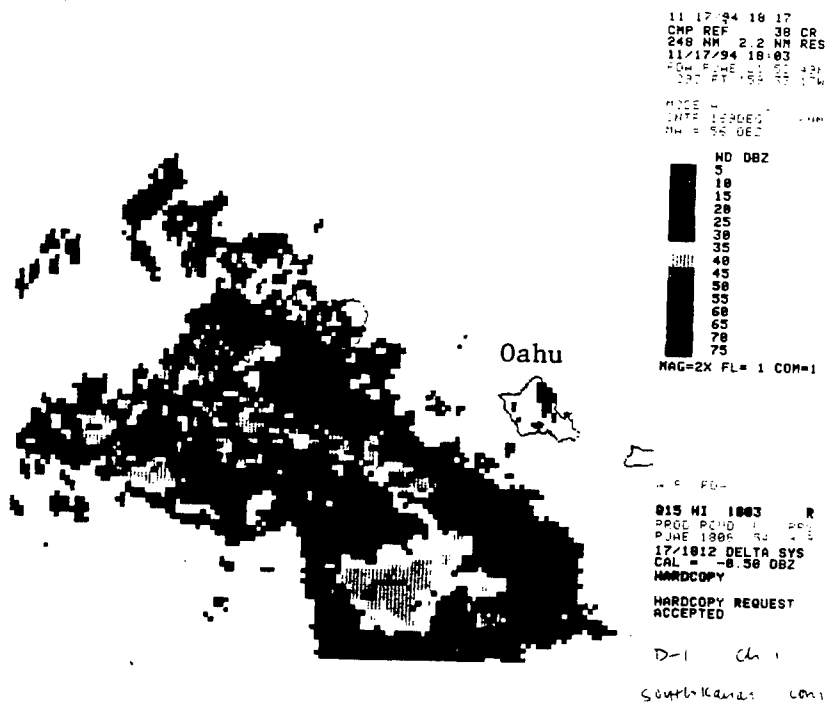

FIGURE A-1. TEST D-1, WEATHER BASE PRODUCT VERIFICATION TEST - BASE REFLECTIVITY. South Kauai (top) and Molokai (bottom) base reflectivities prove to be meteorologically equivalent considering the radars' range limits. Note the similarity of the large weather masses relative to the common island of Oahu.



STN	ID	ST	NO	NO	NEG	53	12.9	25	28.32	0	0	11389
27	244	183	NO	NO	NEG	53	12.9	25	28.32	0	0	11389

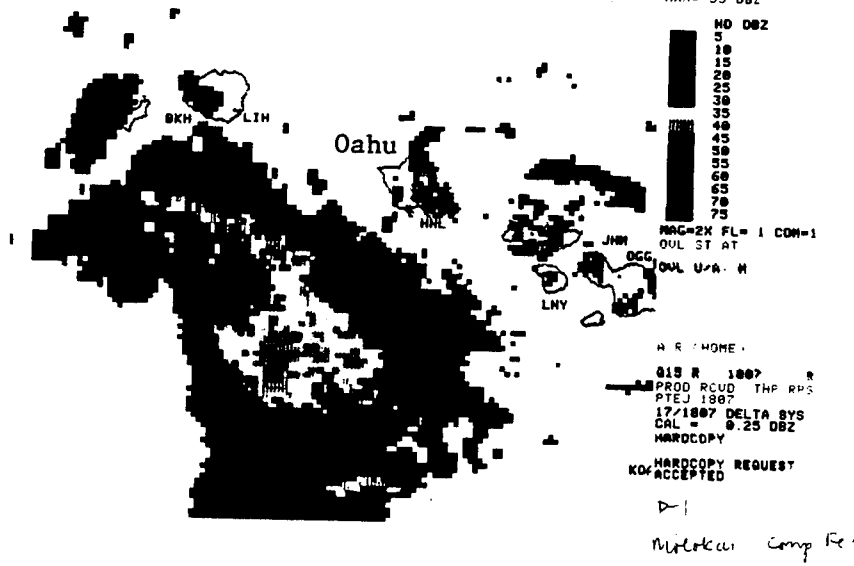

FIGURE A-2. TEST D-1, WEATHER BASE PRODUCT VERIFICATION TEST - COMPOSITE REFLECTIVITY. South Kauai (top) and Molokai (bottom) composite reflectivities prove to be meteorologically equivalent considering the radars' range limits. Note the similarity of the large weather masses relative to the common island of Oahu.

**Test:** D-2, Channel Switching Tests

**Test Objective/  
Evaluation Criteria:** Measure the redundant configuration operational performance during channel switchover.

**Test Description:** Control was transferred from Channel 1 to Channel 2 and back to Channel 1 from the UCP. Channels and Radar Data Acquisition (RDA) Units were placed in various modes of operation in on-line, off-line operate, and standby modes.

**Data Collection and  
Analysis Method:** ACW-200 and NWS monitored the RDA status screen to verify channel control transfer and channel switching, and monitored the PUP to document access time to base products following a channel switchover. PUP plots and Unit Control Position (UCP) screen printouts were collected. Test Comments/Notes Sheet #13.

**Test Results:** ACW-200 and NWS successfully verified channel controlling and channel switching by executing UCP commands (commands: *RD, STAN; RE, C, WXMAN1; RD, OP*) and utilizing the A/B switch. This channel switching capability was verified while operating under both utility and auxiliary power. Also, ACW-200 and NWS successfully verified the access time to base products following a channel switchover. Finally, ACW-200 determined it was not possible to switch between utility and auxiliary power from the noncontrolling channel.

**Service Reports  
Generated:** Service Report #12, #14, #15, #16.

**COIs Addressed:** N/A

**Test:** D-3, Redundant Configuration System Tests

**Test Objective/  
Evaluation Criteria:** Evaluate the FAA redundant configuration features with regard to their effect on system performance.

**Test Description:** For the entire test period during operational testing, enhancements or deficiencies to overall system performance that were caused by the redundant features of the Offshore NEXRAD system were identified and documented.

**Data Collection and  
Analysis Method:** NWS compared PUP products to verify that redundancy does not affect system performance. During the test period, the technicians became familiar with FAA redundant configuration NEXRAD while working on the system. Test Comments/Notes sheets #14, #15, and #16 identify comments on the redundancy design in waveguide pressurization, redundant pedestal electronics, and redundant statistical multiplexers, respectively.

**Test Results:** ACW-200 and NWS successfully verified that the redundant features do not affect weather detection, processing, and display performance. Also, NWS meteorologists reported no degradation of data because of redundancy, and no significant difference between redundant channel weather data. The technicians, overall, felt that the redundant features performed satisfactorily.

**Service Reports  
Generated:** None

**COIs Addressed:** N/A

**Test:** D-4, System Operational Mode Test

**Test Objective/  
Evaluation Criteria:** Evaluate the FAA redundant configuration performance under various operational modes.

**Test Description:** The system was cycled through various operational modes and any enhancements or deficiencies to weather detection capabilities were documented.

**Data Collection and  
Analysis Method:** ACW-200 and NWS requested and compared Kauai and Molokai NEXRAD weather products at the respective PUPs to determine each channel's ability to detect, process, and display weather data. Also, ACW-200 and NWS input UCP commands (commands: *RD, STAN; RD, OF*) to put the offline channel into standby and off-line operate modes. PUP plots were collected.

**Test Results:** ACW-200 and NWS successfully verified each channel's ability to detect, process, and display accurate weather data (base reflectivity, base velocity, and spectrum width) while the off-line channel was put into both standby and off-line operate modes. The NWS meteorologist compared Kauai NEXRAD weather data to an actual baseline of weather data (Molokai NEXRAD data). Refer to figure A-3.

**Service Reports  
Generated:** None

**COIs Addressed:** N/A

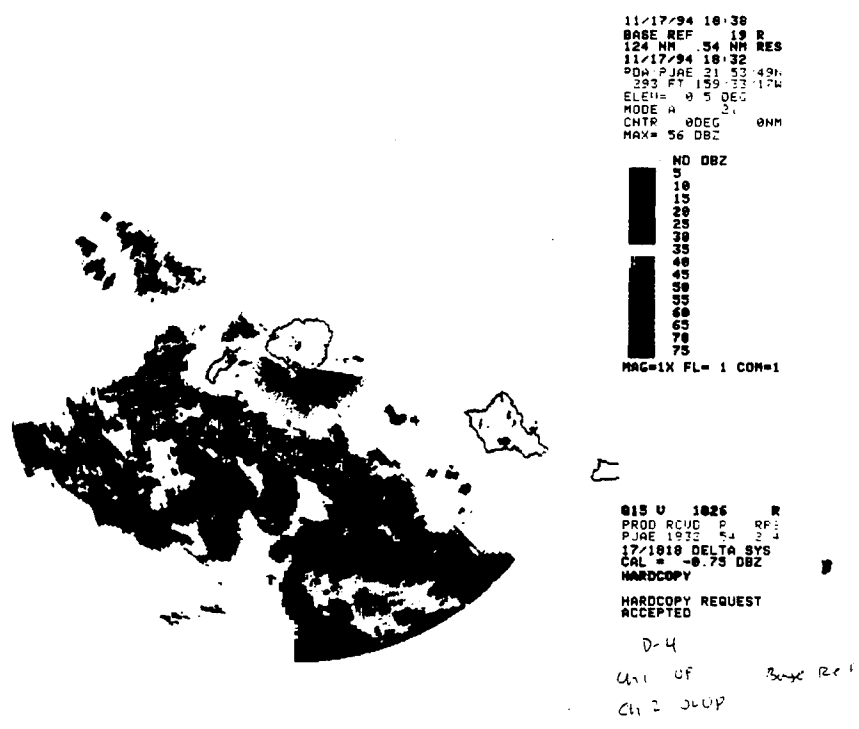
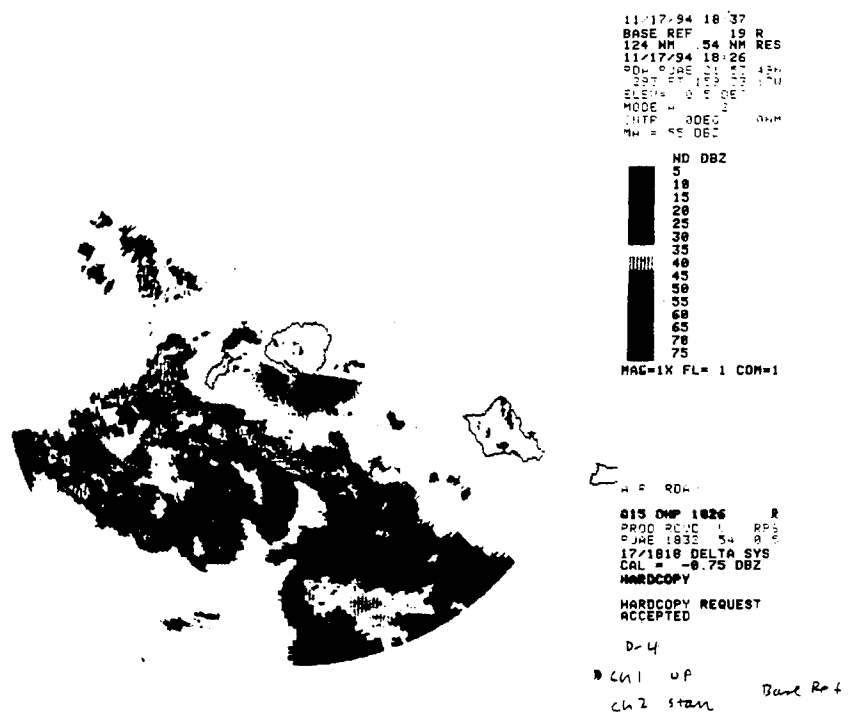

FIGURE A-3. TEST D-4, SYSTEM OPERATIONAL MODE TESTS. Channel 1 South Kauai base reflectivity remains unchanged when offline channel 2 is in STANDBY (top) and OFFLINE OPERATE (bottom); interchannel leakage is not present.

**Test:** D-5, Reliability

**Test Objective/  
Evaluation Criteria:** Assess the overall reliability of the FAA redundant configuration in an operational environment.

**Test Description:** System performance was monitored for the entire OT&E test period, including OT&E Shakedown as of January 20, 1995. Any condition that affected overall reliability of the Offshore NEXRAD system was identified and recorded.

**Data Collection and  
Analysis Method:** Any data relevant to system reliability was collected during the test period. Service Reports were written and a questionnaire was distributed to the technicians at the end of testing.

**Test Results:** Overall system reliability requires improvement. The results of ACW reliability data combined with preliminary AOS data as of January 20, 1995, indicate a system Mean Time Between Failure (MTBF) of 209 hours. System reliability is far below the NAS-SS-1000 specification of 4037 hours. The MTBF figure of 209 hours reflects critical failures only, of the system in an operational environment. Since there were critical failures and noncritical failures during testing, this figure would be significantly lower if noncritical failures were included. Many factors were identified which adversely affect the overall reliability of the system including site specific anomalies, NEXRAD system anomalies, local utility power and configuration issues. Recommendations are provided in section 7 which will, cost effectively, increase the reliability of the system in an operational environment.

**Service Reports  
Generated:** Refer to the Service Report Summary in Section 5.

**COIs Addressed:** Measure Of Suitability (MOS) A-1,  
MOS A-3

**Test:** D-6, Maintainability

**Test Objective/  
Evaluation Criteria:** Assess the overall Maintainability of the FAA redundant configuration in an operational environment.

**Test Description:** System performance was monitored for the entire OT&E test period, including OT&E Shakedown as of January 20, 1995. Any condition that affected overall maintainability of the Offshore NEXRAD system was identified and recorded. Upon completion of testing, all participating technicians completed a maintainability questionnaire.

**Data Collection and  
Analysis Method:** Any data relevant to system maintainability was collected during the test period. Service Reports were written and a questionnaire was distributed to the technicians at the end of testing.

**Test Results:** Overall system maintainability requires improvement. The results of ACW maintainability data combined with preliminary Operational Support Service (AOS) data as of January 20, 1995, indicate a system maintainability of 0.7 hours Mean Time To Repair (MTTR) in an ideal environment. This MTTR figure of 0.7 hours reflects critical failures only, in an ideal operational environment, and is outside the NAS-SS-1000 specification of 0.5 hours or less. The actual MTTR, including the support and logistics environment, was 9.3 hours. This MTTR figure reflects the actual performance of the system in an operational environment. Results and Discussion are provided in section 5 which identify factors affecting the overall maintainability of the system. Conclusions are provided in section 6 and recommendations are provided in section 7 which will, cost effectively, increase the maintainability of the system in an operational environment.

**Service Reports  
Generated:**

Refer to the Service Report Summary in  
Section 5.

**COIs Addressed:**

MOS A-2, MOS A-3

**Test:**

D-7, Availability

**Test Objective/  
Evaluation Criteria:**

Assess the overall availability of the FAA redundant configuration in an operational environment.

**Test Description:**

System performance was monitored for the entire OT&E test period, including OT&E Shakedown as of January 20, 1995. Any condition that affected overall availability of the Offshore NEXRAD system was identified and recorded.

**Data Collection and  
Analysis Method:**

Any data relevant to system availability was collected during the test period. Service Reports were written and a questionnaire was distributed to the technicians at the end of testing.

**Test Results:**

Overall system availability requires improvement. The results of ACW availability data combined with preliminary AOS data as of January 20, 1995, indicate the following:

Test data showed the Kauai NEXRAD had an Inherent Availability (Ai) of 0.99644659. The NAS-SS-1000 specification is 0.99987616. This is a measure of the system's performance in an ideal support environment based on critical failures only. To put this figure in perspective, the system will be off-the-air about 31 hours per year (i.e.,  $(1 - 0.99644659) \times 8760 = 31$  hours) to perform the corrective maintenance on just the critical failures that occur.

Test data showed the Kauai NEXRAD had an operational availability of 0.95739808. This is a measure of the system's performance in the true support environment at Kauai, based on critical failures only. To put this figure in perspective, the system will be off-the-air about 373 hours per year (i.e.,  $(1 - 0.95739808) \times 8760 = 373$  hours) to actually perform corrective maintenance on just the critical failures of the Kauai NEXRAD, in its operational

environment. These figures do not identify the yearly total of required corrective maintenance hours for the system. These figures are based on critical failures only. During ACW's OT&E test period, critical failures, and noncritical failures occurred. The total corrective maintenance hours required for the Kauai NEXRAD per year will be much higher than the corrective maintenance hours required to repair critical failures only. Recommendations are provided in section 7 which will, cost effectively, increase the availability of the system in an operational environment.

**Service Reports  
Generated:**

Refer to the Service Reports Summary in section 5.

**COIs Addressed:**

MOS A-1

**Test:** D-8, Degraded Operations Tests

**Test Objective/  
Evaluation Criteria:** Evaluate performance of the FAA redundant configuration when the system is in various degraded modes of operation.

**Test Description:** Evaluated system performance and its capability to perform weather detection as it was cycled through various degraded modes of operation. Equipment failures were induced; system response times to failure and any resulting deficiencies affecting weather detection capability were recorded. This test was conducted simultaneously with test D-29, Alarm/Alert Verification Time.

**Data Collection and  
Analysis Method:** Test Comments/Notes Sheet #17, #19, #20, #21, #22, #23.

**Test Results:** Based on information received from system specialists and from the redundancy training course, Procedure D-8 was rewritten to perform a more accurate test for degraded operations. The degraded operations test results were positive. The tests performed on the system were designed to detect problems within the system and report them to the operator. In all cases during this test, when a failure was introduced, at no time did the operator receive corrupted data without knowing it via an alarm. In some instances when no alarm was present, the operator was not passed corrupted data, and the operator eventually recognized a problem when no communication between the UCP/PUP and the radar site prohibited controlling of, or product requests from the radar. The system responded satisfactorily when placed in various modes of degraded operations.

**Service Reports  
Generated:** Service Report #22.

**COIs Addressed:** N/A

**Test:**

D-9, Safety Tests

**Test Objective/  
Evaluation Criteria:**

Evaluate the Offshore NEXRAD site for applicable FAA Safety Regulations to insure a hazard-free work area.

**Test Description:**

The Airway Facilities Division Safety Officer from Western Pacific Region (AWP) 464.10S, assisted by a representative from AWP-483.5, and an Industrial Hygienist from Research Management Consultants Inc., conducted a comprehensive safety inspection of the Kauai NEXRAD site in accordance with FAA Order 3900.19A and applicable regional and local standards.

**Data Collection and  
Analysis Method:**

Ionizing X-ray and non-ionizing Radio Frequency (RF) radiation measurements were taken on the Kauai NEXRAD on November 10, 1994. Safety data collection occurred on November 29 and November 30, 1994. The performance of the general safety inspection included typical "walk-through" survey methods and collecting detailed notes of conditions observed which could be potentially hazardous to the health and safety of FAA personnel. Noise and illumination readings were taken in the electronic equipment room, engine generator building and antenna tower.

**Test Results:**

Hazardous radiation test results concluded that radiation readings were acceptable and below national standards for ionizing x-ray radiation and non-ionizing RF. The only noise reading above 85 decibels (dB) was measured in the engine generator room, when the standby generator was running. This reading was instantaneous and did not factor in the 8-hour time-weighted average. Two suggestions to improve NEXRAD system safety are offered and these are detailed in section 7. FAA Form 3900-1, Occupational Safety and Health Inspection Report, records 17 items (listed on following pages) which describe unsafe or unhealthful

conditions detected during the inspection of the Kauai NEXRAD. Eleven of these items are in violation of the Occupational and Safety Health Act (OSHA), 29 CFR 1910 although the NTR, November 1, 1991, paragraph 3.3.6, states in part, that the NEXRAD system shall be compliant in all respects with OSHA Safety and Health Act (29 CFR 1910).

Item No.	Location	Description of Unsafe or Unhealthful Condition (Reference any applicable safety/health std)
1	Engine Gen Bldg	Diesel fuel storage tanks (500 gallon capacity) are too close to a source of ignition. 29 CFR 1910.106(e) (6)
2	Engine Gen Bldg	Standby engine generator has no bypass isolation switch. 29 CFR 1910.333(a) (1)
3	Engine Gen Bldg	Rise into engine generator room is 16 inches. There is no fixed stair/step outside of entrance door. 29 CFR 1910.24(b)
4	Engine Gen Bldg	Means of egress from engine generator room is 10 inches above floor. 29 CFR 1910.37(j)
5	Elect Eq Bldg	Metal cable tray sections in electronic equipment room and between electronic equipment building and antenna tower are not bonded together. National Electric Code (NEC) Article 250-75
6	Elect Eq Bldg	Vertical cable tray in electronic equipment room is not secured to floor. NEC Article 318-5(a)
7	Elect Eq Bldg	Working clearances between south wall and rear of transmitter access panels are less than 36 inches (10,000 volt access panels = 33 inches and 300 volt access panels = 13 inches). 29 CFR 1910.303(g)
8	Elect Eq Bldg	Working clearances for 2 alarm panels on east wall are less than 36 inches (north side of entrance door = 28 inches and south side of entrance door = 21 inches). 29 CFR 1910.303(g)
9	Elect Eq Bldg	Facility lockout/tagout program needs to be established. 29 CFR 1910.147 and FAA Order 3900.49

Item No.	Location	Description of Unsafe or Unhealthful Condition (Reference any applicable safety/health std)
10	Elect Eq Bldg	Main disconnect switch in electrical distribution panel needs to be identified as the service disconnecting means. <b>NEC Article 230-70(b)</b>
11	Elect Eq Bldg	Two 500 kcmil (thousand circular mils) cables need to be connected between the main multipoint ground plates and the earth electrode system. <b>FAA-STD-019b, Para., 3.11.2, Page 20</b>
12	Elect Eq Bldg	Standard safety board needs to be installed. <b>FAA Order 3900.19A, Para., 139., Page 189</b>
13	Antenna Tower	The section of stairs below the antenna dome is not in compliance with the current OSHA Standard (tread run is only 6 1/4 inches). <b>29 CFR 1910.24</b>
14	Antenna Tower	Illumination readings inside the antenna dome are below the minimum recommended American National Standards Institute (ANSI) levels. <b>29 CFR 1910.333(c)(4)</b>
15	Antenna Tower	Tower has no obstruction lighting or marking. <b>AC 70/7460-1H</b>
16	Antenna Tower	No portable fire extinguisher is available in the antenna dome. <b>29 CFR 1910.157(c)</b>
17	Antenna Tower	No radiation hazard warning signs or trespassing signs are posted. <b>29 CFR 1910.97(a)(3)</b>

Service Reports  
Generated:

None

COIs Addressed:

N/A

<b>Test:</b>	D-10, Security Tests
<b>Test Objective/ Evaluation Criteria:</b>	Evaluate the Offshore NEXRAD site for security to insure no unauthorized access to equipment.
<b>Test Description:</b>	An FAA qualified Security inspector from AWP-700, Civil Aviation Security Division, conducted an evaluation of the NEXRAD's adherence to FAA Order 1600.6C, and applicable regional or local standards.
<b>Data Collection and Analysis Method:</b>	A Physical Security Survey and Risk Assessment of the NEXRAD site was conducted by qualified FAA security personnel. Information for the Physical Security Survey and Risk Assessment was acquired from document reviews, interviews, and survey team member observations.
<b>Test Results:</b>	ACW-200 received the Security report from AWP-700. The report detailed four recommendations to improve security and these are listed in section 7 of this document.
<b>Service Reports Generated:</b>	None
<b>COIs Addressed:</b>	N/A

**Test:** D-11, Site Adaptation Data Test

**Test Objective/  
Evaluation Criteria:** Evaluate the site adaptation data of the FAA redundant configuration.

**Test Description:** Site adaptation data was sampled and evaluated for each channel of the redundant configuration.

**Data Collection and  
Analysis Method:** Site adaptation data was collected at each of the RDA maintenance terminals. The data for each channel were compared as well as the values identified in the test procedure.

**Test Results:** Test results were positive. All adaptation data identified in the test procedure were verified as acceptable and satisfactory.

**Service Reports  
Generated:** None

**COIs Addressed:** N/A

**Test:** D-12, Operational Status Verification Test

**Test Objective/  
Evaluation Criteria:** Verify that the FAA redundant configuration provides operational status at the UCP and RDA maintenance terminals.

**Test Description:** The RDA maintenance terminals and UCP were used to verify that redundant configuration status information was current and correct for both the controlling and noncontrolling channels.

**Data Collection and  
Analysis Method:** ACW-200 input UCP commands (commands: *RE,D; ST,RD,W; ST,RD,TO*) to access status screens. UCP screen printouts were collected and examined.

**Test Results:** ACW-200 successfully verified that redundant configuration status (RDA, Radar Product Generator (RPG), Wideband Communication Link, and Tower) was provided at the UCP.

**Service Reports  
Generated:** None

**COIs Addressed:** N/A

**Test:** D-13, UCP Operational Command Verification Test

**Test Objective/  
Evaluation Criteria:** Verify that the FAA redundant configuration accepts operational control commands from the UCP.

**Test Description:** The system was tested to verify that the redundant configuration would accept operational commands from the UCP.

**Data Collection and  
Analysis Method:** ACW-200 input 8-9 UCP commands for each channel, and monitored UCP FEEDBACK line to verify command acceptance. Several of these commands included the following: (commands: *U,C,C,21* to connect comline #21; *ST,RP* to display RPG alarms status; *RD,OP* to command the on-line channel to operate; *RD,A* to switch from utility to auxiliary power; and *ST,RD,TO* to display tower communications status). UCP screen printouts were collected and examined.

**Test Results:** ACW-200 successfully verified the acceptance of all operational commands input at the UCP.

**Service Reports  
Generated:** Service Report #4.

**COIs Addressed:** N/A

**Test:** D-14, UCP Operational Processing Verification Test

**Test Objective/  
Evaluation Criteria:** Verify that the FAA redundant configuration processes operational control commands from the UCP.

**Test Description:** The system was tested to verify that the redundant configuration control commands were executed by observing the status log for each channel at the UCP and by physical verification whenever possible.

**Data Collection and  
Analysis Method:** ACW-200 input 8-9 UCP commands for each channel, and monitored the UCP to verify proper response. Several of these commands included the following: (commands: *U,C,D,21* to disconnect comline #21; *RE,D* to display redundant status; *ST,C* to provide communications status; *RD,STAN* to command the on-line channel to standby; and *ST,RD,W* to display wideband communications status). UCP screen printouts were collected and examined.

**Test Results:** ACW-200 successfully verified the processing of the operational control commands input at the UCP during Test D-13.

**Service Reports  
Generated:** None

**COIs Addressed:** N/A

**Test:** D-15, System Timing/Recording Verification Test

**Test Objective/  
Evaluation Criteria:** Verify that the FAA redundant configuration can receive timing synchronized to Universal Time Coordinated (UTC) to support system recording (D-15).

**Test Description:** External change to system timing was initiated at the UCP and RDA maintenance terminals. UCP system status screen was reviewed. This test was conducted simultaneously with Tests D-16 and D-18.

**Data Collection and  
Analysis Method:** ACW-200 input a time change at the UCP and RDA maintenance terminal, and monitored the UCP status screen to verify that new entries were tagged with the proper time. Test Comments/Notes Sheet #8.

**Test Results:** ACW-200 and NWS successfully verified that the redundant configuration system time can be changed by simultaneously changing the time at the UCP and at the RDA maintenance terminal. (Each terminal has its own clock for each channel.) The time change was verified at the UCP system status log to verify system recording.

**Service Reports  
Generated:** None

**COIs Addressed:** N/A

**Test:** D-16, System Timing/Distribution Verification Test

**Test Objective/  
Evaluation Criteria:** Verify that the FAA redundant configuration can receive timing synchronized to UTC to support the distribution of products.

**Test Description:** External change to system timing was initiated at the UCP and RDA maintenance terminals. PUP product outputs were examined. This test was conducted simultaneously with Tests D-15 and D-18.

**Data Collection and  
Analysis Method:** ACW-200 input a time change at the UCP and RDA maintenance terminal, and monitored the PUP to verify that weather products were received with the proper time. Test Comments/Notes Sheet #8.

**Test Results:** ACW-200 and NWS successfully verified that the redundant configuration system time can be changed by simultaneously changing the time at the UCP and at the RDA maintenance terminal. (Each terminal has its own clock for each channel.) The time change was verified on the PUP product outputs to verify distribution of products.

**Service Reports  
Generated:** None

**COIs Addressed:** N/A

**Test:** D-17, Maintain Timing/Recording Verification Test

**Test Objective/  
Evaluation Criteria:** Verify that the FAA redundant configuration can maintain timing synchronized to UTC to support system recording.

**Test Description:** Tests were accomplished on both channels. System status logs were examined to verify system recording. This test was conducted simultaneously with Test D-19.

**Data Collection and  
Analysis Method:** ACW-200 input a time change at the UCP and RDA maintenance terminal, and monitored the UCP status screen to verify that new entries were tagged with the proper time and that the system maintained the proper time for a period of 5 minutes. Test Comments/Notes Sheet #8.

**Test Results:** ACW-200 and NWS successfully verified that the redundant configuration could maintain time after the time change of Tests D-15/16/18. The time change was maintained on the UCP system status log to verify system recording.

**Service Reports  
Generated:** None

**COIs Addressed:** N/A

**Test:** D-18, System Timing/Maintenance Verification Test

**Test Objective/  
Evaluation Criteria:** Verify that the FAA redundant configuration can receive timing synchronized to UTC to support system maintenance.

**Test Description:** External change to system timing was initiated at the UCP and RDA maintenance terminals. RDA maintenance terminals were inspected. This test was conducted simultaneously with Tests D-15 and D-16.

**Data Collection and  
Analysis Method:** ACW-200 input a time change at the UCP and RDA maintenance terminal, and monitored the RDA maintenance terminal to verify that new entries were tagged with the proper time. Test Comments/Notes Sheet #8.

**Test Results:** ACW-200 and NWS successfully verified that the redundant configuration system time can be changed by simultaneously changing the time at the UCP and at the RDA maintenance terminal. (Each terminal has its own clock for each channel.) The time change was verified on the RDA maintenance terminal to verify system maintenance.

**Service Reports  
Generated:** None

**COIs Addressed:** N/A

**Test:** D-19, Maintain Timing/Product Distribution Verification Test

**Test Objective/  
Evaluation Criteria:** Verify that the FAA redundant configuration can maintain timing synchronized to UTC to support the distribution of products.

**Test Description:** Tests were accomplished on both channels. PUP product outputs were inspected to verify distribution of products. This test was conducted simultaneously with Test D-19.

**Data Collection and  
Analysis Method:** ACW-200 input a time change at the UCP and RDA maintenance terminal, and monitored the PUP to verify that weather products were tagged with the proper time and that the system maintained the proper time for a period of 5 minutes. Test Comments/Notes Sheet #8.

**Test Results:** ACW-200 and NWS successfully verified that the redundant configuration could maintain time after the time change of Tests D-15/16/18. The time change was maintained on the PUP product outputs to verify distribution of products.

**Service Reports  
Generated:** None

**COIs Addressed:** N/A

**Test:** D-20, System Elevation/Azimuth Verification Tests

**Test Objective/  
Evaluation Criteria:** Verify that the redundant configuration detects weather phenomena between 0 and 360° in azimuth, from -1 to 45° in elevation, and over an unambiguous range of 1 to 460 kilometers (km).

**Test Description:** Tests were conducted on both channels. The NWS meteorologist selected Volume Coverage Pattern (VCP) 11 to verify the on-line channel was collecting weather data per required elevation, azimuth, and range. Antenna was manually adjusted from -1 to 45° to demonstrate upper and lower limits of elevation coverage capacity.

**Data Collection and  
Analysis Method:** The NWS meteorologist selected VCP 11 at the UCP (command: *RD,CH,11*), and monitored the PUP to verify weather collection per required elevation (partial), azimuth, and range. Technicians verified the antenna's upper and lower elevation limits. PUP plots were collected and examined. Test Comments/Notes Sheet #5.

**Test Results:** ACW-200 and NWS successfully verified that the redundant configuration detects weather phenomena between 0 and 360° in azimuth, from 0.5 to 19.5° in elevation, and over an unambiguous range of 1 to 460 km, utilizing the three available VCPs. In addition, technicians verified the antenna's upper and lower elevation limits of -1 and 45°, respectively, from the RDA maintenance terminal. Refer to figures A-4, A-5, and A-6.

**Service Reports  
Generated:** None

**COIs Addressed:** N/A

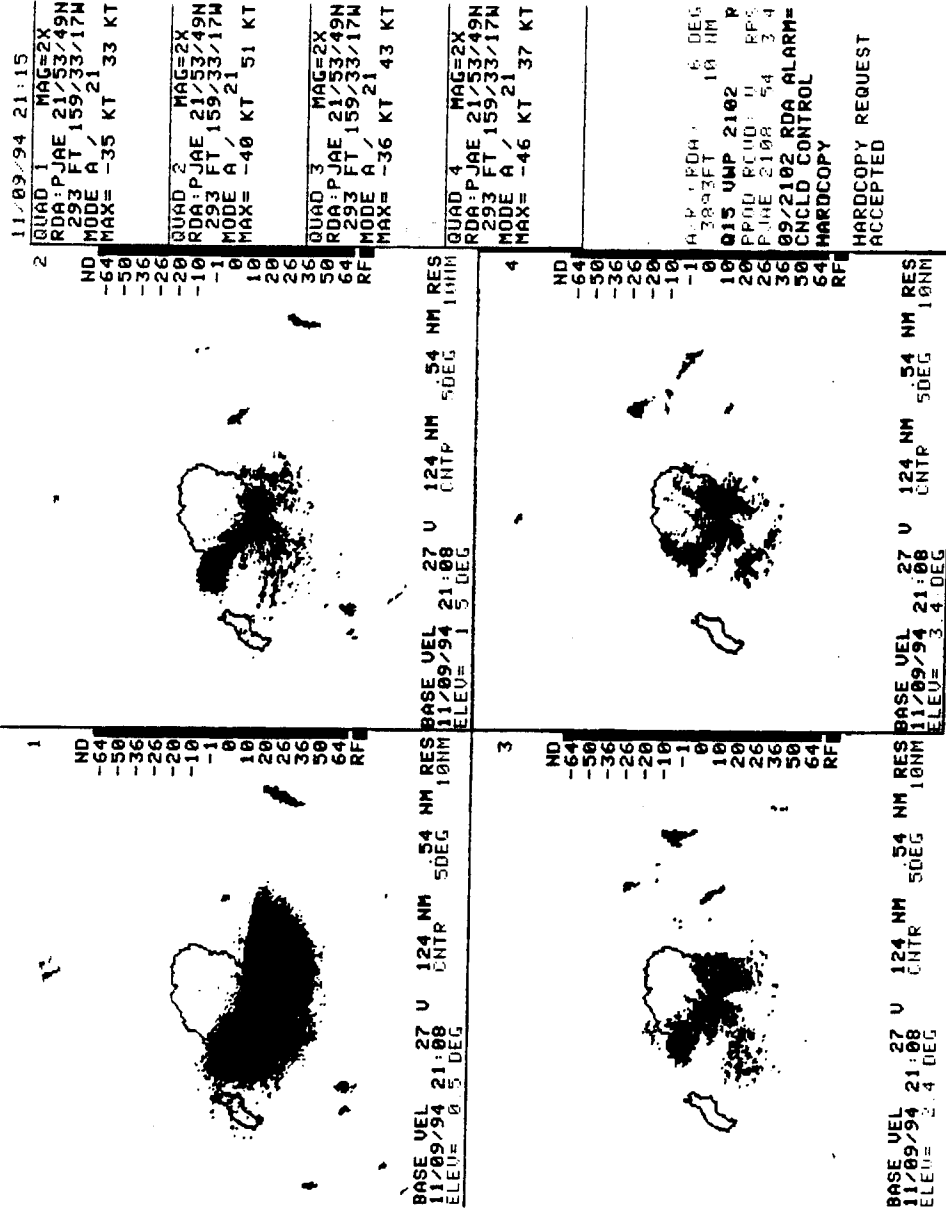

11/09/94 21:15

QUAD 1 MAG=2X  
RDA:PJAE 21/53/49N  
293 FT 159/33/17W  
MODE A / 21  
MAX= -35 KT 33 KT

QUAD 2 MAG=2X  
RDA:PJAE 21/53/49N  
293 FT 159/33/17W  
MODE A / 21  
MAX= -40 KT 51 KT

QUAD 3 MAG=2X  
RDA:PJAE 21/53/49N  
293 FT 159/33/17W  
MODE A / 21  
MAX= -36 KT 43 KT

QUAD 4 MAG=2X  
RDA:PJAE 21/53/49N  
293 FT 159/33/17W  
MODE A / 21  
MAX= -46 KT 37 KT

4.0K 1.0DA 6 DEG  
3893FT 10 NM  
Q15 UMP 2102 P  
20 PPOD PCUD U RFS  
26 P JHE 2102 54 3 4  
36 09/2102 RDA ALARM=  
50 CNCLD CONTROL  
64 HARDCOPY

HARDCOPY REQUEST  
ACCEPTED

D-20 Azimuth  
0 → 360

FIGURE A-4. TEST D-20, SYSTEM ELEVATION/AZIMUTH VERIFICATION TESTS - AZIMUTH. South Kauai detects weather phenomena (base velocity) between 0° and 360° in azimuth.

11/09/94 21:02  
 2 QUAD 1 MAG=2X  
 RDA: PJAE 21/53/49N  
 293 FT 159/33/17W  
 MODE A / 21  
 MAX= 40 DBZ

QUAD 2 MAG=2X  
 RDA: PJAE 21/53/49N  
 293 FT 159/33/17W  
 MODE A / 21  
 MAX= 46 DBZ

QUAD 3 MAG=2X  
 RDA: PJAE 21/53/49N  
 293 FT 159/33/17W  
 MODE A / 21  
 MAX= 41 DBZ

QUAD 4 MAG=2X  
 RDA: PJAE 21/53/49N  
 293 FT 159/33/17W  
 MODE A / 21  
 MAX= 13 DBZ

4 R (RUM) 181 000  
 1368 FT 17 HR  
 015 U 2050 R  
 PROD CODE 50 PPS  
 PJAE 2050 54 1 5  
 09/2102 RDA ALARM=  
 CNCLD CONTROL  
 HARD COPY

HARDCOPY REQUEST  
 ACCEPTED

D 20  
 CAI  
 11/09/94

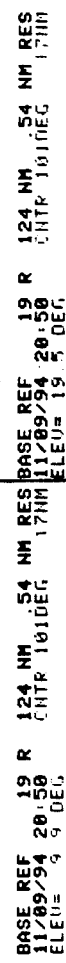
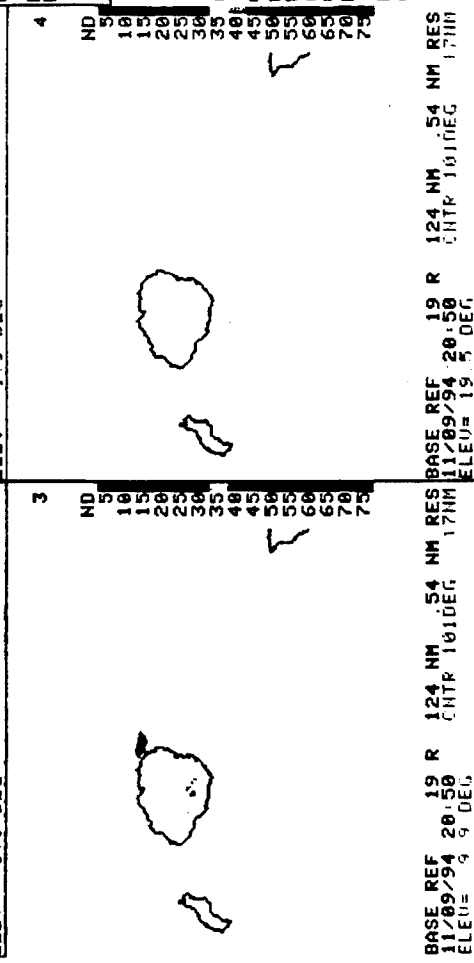
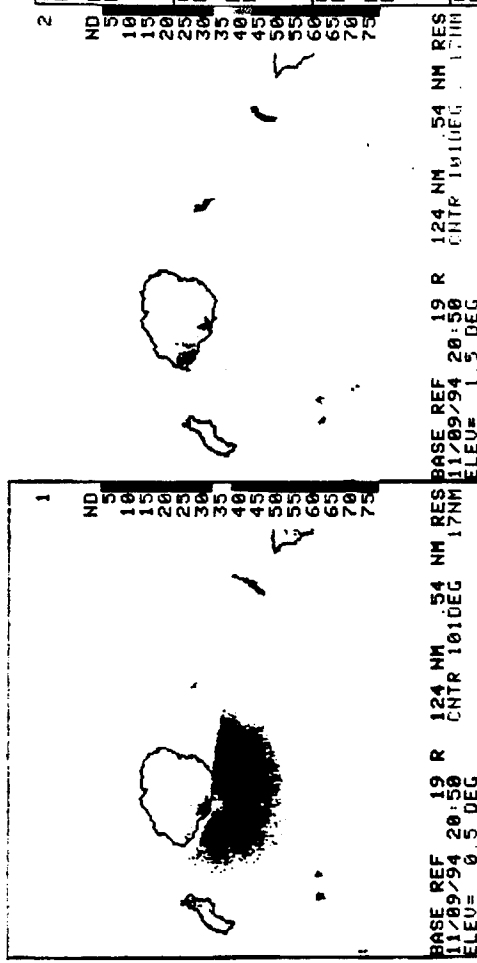

FIGURE A-5. TEST D-20, SYSTEM ELEVATION/AZIMUTH VERIFICATION TESTS - ELEVATION. South Kauai detects weather phenomena (base reflectivity) from 0.5° and 19.5° in elevation. Elevation angles appear on third line of text of each quadrant.

11/09/94 20:19  
 BASE REF 21 R  
 248 NM 2.2 NM RES  
 11/09/94 20:10  
 Plot File 1.53.400  
 248 NM 2.2 NM RES  
 LEGEND: 0.5 DBZ  
 0.0000 0.0000 0.0000  
 0.00 0.00 0.00

ND DBZ  
 5  
 10  
 15  
 20  
 25  
 30  
 35  
 40  
 45  
 50  
 55  
 60  
 65  
 70  
 75

MAG=1X FL= 1 COM=1

POLAR=60 NM 30 DEG

FILE FILE

015 SW 2010 R  
 0000 0000 HI 000  
 0000 2010  
 09/2007 VOL 000  
 PAT= 21  
 HARDCOPY

HARDCOPY REQUEST  
 ACCEPTED

D 20 Karyo

0-460km

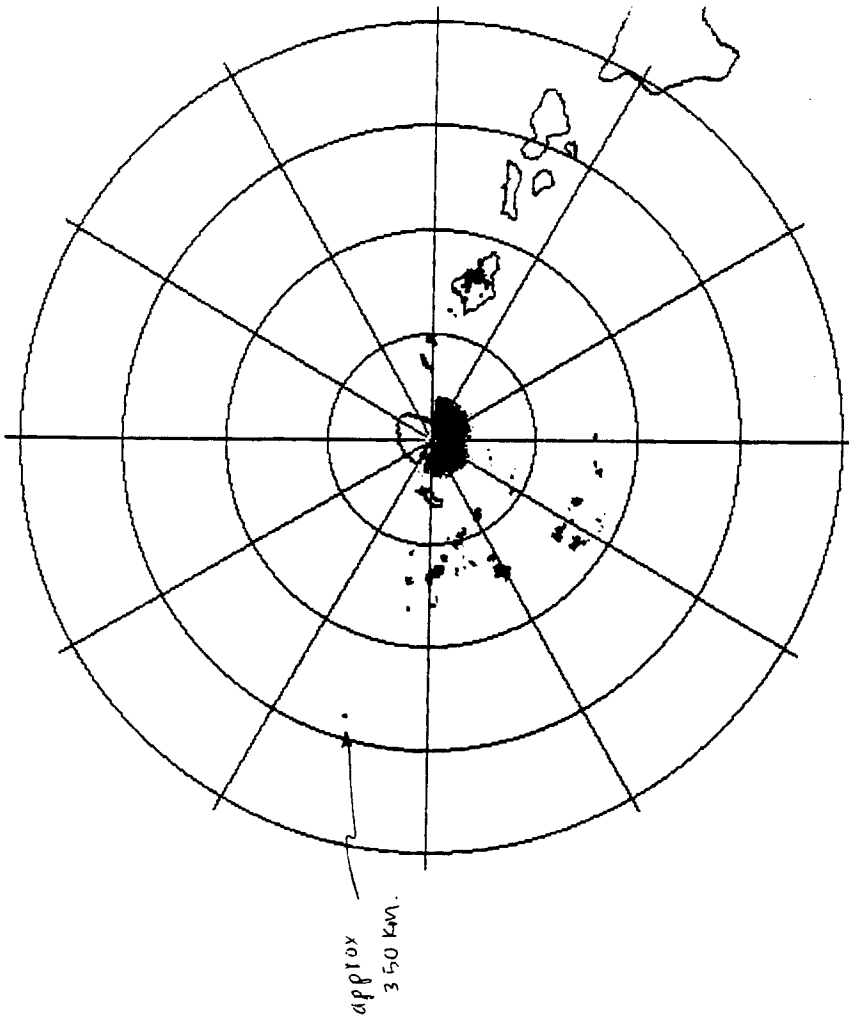

FIGURE A-6. TEST D-20, SYSTEM ELEVATION/AZIMUTH VERIFICATION TESTS - RANGE. South Kauai detects weather phenomena (base reflectivity) over an unambiguous range of 1 to 460 kilometers.

**Test:** D-21, Minimum Detection Verification Test

**Test Objective/  
Evaluation Criteria:** Verify that the redundant configuration provides a minimum detection capability of at least 0 dB signal-to-noise ratio (SNR) for a -8 dBz (Radar Reflectivity Factor) target at 50 km.

**Test Description:** Both channels were tested. The NWS meteorologist selected an appropriate elevation cut of a VCP. The receiver was set to a SNR of 0 dB. A target measuring -8 dBz at 50 km, or equivalent, was measured to demonstrate minimum detection capability.

**Data Collection and  
Analysis Method:** The NWS meteorologist selected and examined PUP weather data to locate an appropriate target. This weather data was used as a benchmark. He then set the SNR to 0 at the UCP, and collected and examined subsequent PUP weather data to verify the requirement.

**Test Results:** ACW-200 and NWS successfully verified that the redundant configuration provides a minimum detection capability of at least 0 dB SNR for a -8 dBz target at 50 km while the off-line channel was in both standby and off-line operate modes. Refer to figure A-7. Also refer to Test Procedure D-21 for Reflectivity versus Range curve.

**Service Reports  
Generated:** None

**COIs Addressed:** N/A

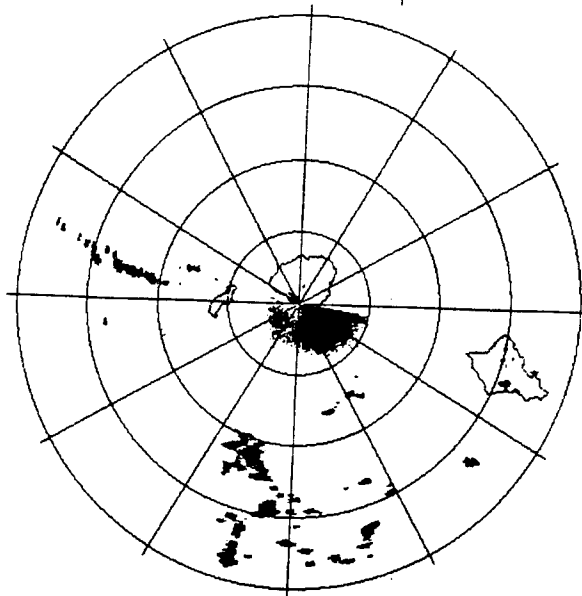

11/22/94 01:22  
 BASE REF 19 R  
 124 NM 54 NM RES  
 11/22/94 01:17  
 RDA FJAE 31 53 49N  
 293 FT 159 33 17W  
 ELEV 0 5 DEG  
 MODE A  
 CNTR 0 DEG 01 ONM  
 MAX 44 DBZ

NO DBZ  
 5  
 10  
 15  
 20  
 25  
 30  
 35  
 40  
 45  
 50  
 55  
 60  
 65  
 70  
 75  
 MAG=1X FL= 1 CON=1

POLAR=30 NM 30 DEG

013 VMP 010 R  
 PROD PCMD L PP  
 PJRE 011 54 0 P

HARDCOPY  
 HARDCOPY REQUEST  
 ACCEPTED

D-21  
 06:20 P 1 at the 502=0  
 06:21 start

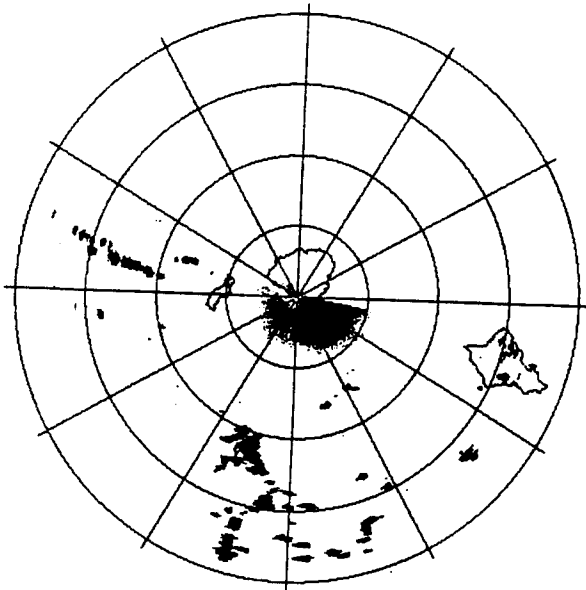

11/22/94 01:20  
 BASE REF 19 R  
 124 NM 54 NM RES  
 11/22/94 01:22  
 RDA FJAE 31 53 49N  
 293 FT 159 33 17W  
 ELEV 0 5 DEG  
 MODE A  
 CNTR 0 DEG 01 ONM  
 MAX 47 DBZ

NO DBZ  
 5  
 10  
 15  
 20  
 25  
 30  
 35  
 40  
 45  
 50  
 55  
 60  
 65  
 70  
 75  
 MAG=1X FL= 1 CON=1

POLAR=30 NM 30 DEG

013 R 0100 R  
 PROD PCMD P PP  
 PJRE 0122 54 0 P

HARDCOPY  
 HARDCOPY REQUEST  
 ACCEPTED

D-21  
 06:20 P 1 at the 502=0  
 06:21 start

FIGURE A-7. TEST D-21, MINIMUM DETECTION VERIFICATION TEST. South Kauai provides a minimum detection capability of at least 0 dB SNR (bottom) for a -8 dBz target at 50 km. (Top plot shows detection capability of a non-zero dB SNR for same target.) Weather cell in SSE sector measures approx. 35 dBz, and is approx. 130 km from radar. Each range ring equals 30 nautical miles (approx. 55.5 km).

**Test:** D-22, Ground Clutter Suppression  
Verification Tests

**Test Objective/  
Evaluation Criteria:** Verify that the redundant configuration provides a ground clutter suppression capability of 50 dB for a mean radial velocity and spectrum width of 4 meters per second or greater.

**Test Description:** At the UCP, the meteorologist modified clutter suppression for VCP azimuth and elevation cuts to provide a 50-dB Ground Clutter Suppression Region. PUP display was used to verify that each channel under test provided 50-dB ground clutter suppression when detecting a target with a mean radial velocity and spectrum width of 4 meters per second or greater.

**Data Collection and  
Analysis Method:** The NWS meteorologist selected and examined PUP weather data to locate an appropriate target. This weather data was used as a benchmark. He then turned clutter filtering off, and collected and examined subsequent PUP weather data to verify the requirement.

**Test Results:** ACW-200 and NWS successfully verified that the redundant configuration provides a ground clutter suppression capability of 50-dB for a mean radial velocity and spectrum width of 4 meters per second or greater by comparing base data with no clutter filtering to base data with clutter filtering. These tests were conducted while the off-line channel was in both standby and off-line operate modes.

**Service Reports  
Generated:** Service Report #18.

**COIs Addressed:** N/A

**Test:** D-23, Storm Mode Verification Test

**Test Objective/  
Evaluation Criteria:** Verify that the redundant configuration provides weather data continuously while operating in the Storm Mode: 14 elevation scans in 5 minutes (VCP 11).

**Test Description:** Storm Mode/VCP 11 was selected at the UCP. At the PUP the time was measured to complete one volume scan for both channels. While measuring time to complete each scan, plots of weather data were made to verify weather detection capability.

**Data Collection and  
Analysis Method:** The NWS meteorologist selected Storm Mode/VCP 11 at the UCP (command: *RD,CH,11*), and verified weather data was available for each elevation scan. PUP plots were collected and examined.

**Test Results:** ACW-200 and NWS successfully verified that the redundant configuration provides weather data (base reflectivity) continuously while operating under Storm Mode/VCP 11. As required, ACW-200 and NWS updated Routine Product Set (RPS) lists from the Application Terminal to include desired weather products and elevation scans. Also, ACW-200 and NWS verified the access time to successive base products.

**Service Reports  
Generated:** None

**COIs Addressed:** N/A

**Test:** D-24, Computer Sizing Mode Verification Test

**Test Objective/  
Evaluation Criteria:** Verify that the redundant configuration provides weather data continuously while operating in the Computer Sizing Mode: 9 elevation scans in 6 minutes (VCP 21).

**Test Description:** Computer Sizing Mode/VCP 21 was selected at the UCP. At the PUP the time was measured to complete one volume scan for both channels. While measuring time to complete each scan, plots of weather data were made to verify weather detection capability.

**Data Collection and  
Analysis Method:** The NWS meteorologist selected Computer Sizing Mode/VCP 21 at the UCP (command: *RD,CH,21*), and verified weather data was available for each elevation scan. PUP plots were collected and examined.

**Test Results:** ACW-200 and NWS successfully verified that the redundant configuration provides weather data (base reflectivity) continuously while operating under Computer Sizing Mode/VCP 21. As required, ACW-200 updated RPS lists from the Application Terminal to include desired weather products and elevation scans. Also, ACW-200 verified the access time to successive base products.

**Service Reports  
Generated:** None

**COIs Addressed:** N/A

**Test:** D-25, Clear Air Mode Verification Test

**Test Objective/  
Evaluation Criteria:** Verify that the redundant configuration provides weather data continuously while operating under the Clear Air Mode: 5 elevation scans in 10 minutes (VCP 31).

**Test Description:** Clear Air Mode/VCP 31 was selected at the UCP. At the PUP the time was measured to complete one volume scan for both channels. While measuring time to complete each scan, plots of weather data were made to verify weather detection capability.

**Data Collection and  
Analysis Method:** The NWS meteorologist selected Clear Air Mode/VCP 31 at the UCP (command: *RD,CH,31*), and verified weather data was available for each elevation scan. PUP plots were collected and examined.

**Test Results:** ACW-200 and NWS successfully verified that the redundant configuration provides weather data (base velocity) continuously while operating under Clear Air Mode/VCP 31. As required, ACW-200 updated RPS lists from the Application Terminal to include desired weather products and elevation scans. Also, ACW-200 verified the access time to successive base products. Refer to figures A-8, A-9, and A-10.

**Service Reports  
Generated:** None

**COIs Addressed:** N/A

NEXRAD UNIT STATUS  
 TIME STATUS RCUD FROM RPG: 23:53 11/09/94

NEW PRODUCT STATUS: AVAILABLE  
 BASE DATA ENABLED: REF UEL 3M  
 OPERATIONAL MODE: 0CP: 8 31  
 DED. RPG COMM: ENABLED CONNECTED  
 RPG AVAILABILITY: AVAIL MAINT RORD  
 RPG NARROWBAND: NORMAL  
 RPG SOFTWARE: OPERATE  
 ALARMS: REDUNDANT CHANNEL  
 RDA AVAILABILITY: AVAIL MAINT RORD  
 RDA SOFTWARE: OPERATE  
 DELTA SYS: CAL -0.50 DBZ  
 RDA ALARMS: TOWER/UTIL

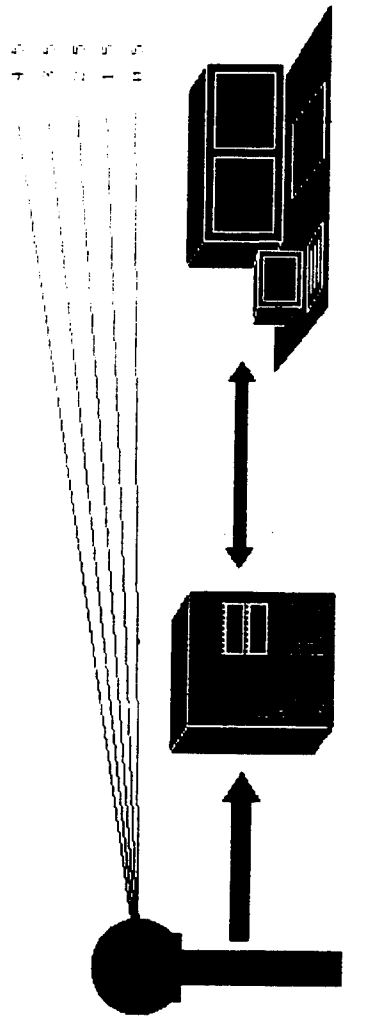

FIGURE A-8. TEST D-25, CLEAR AIR MODE VERIFICATION TEST. South Kauai Clear Air Mode (VCP 31) contains five elevation angles (0.5°, 1.5°, 2.5°, 3.5°, and 4.5°).

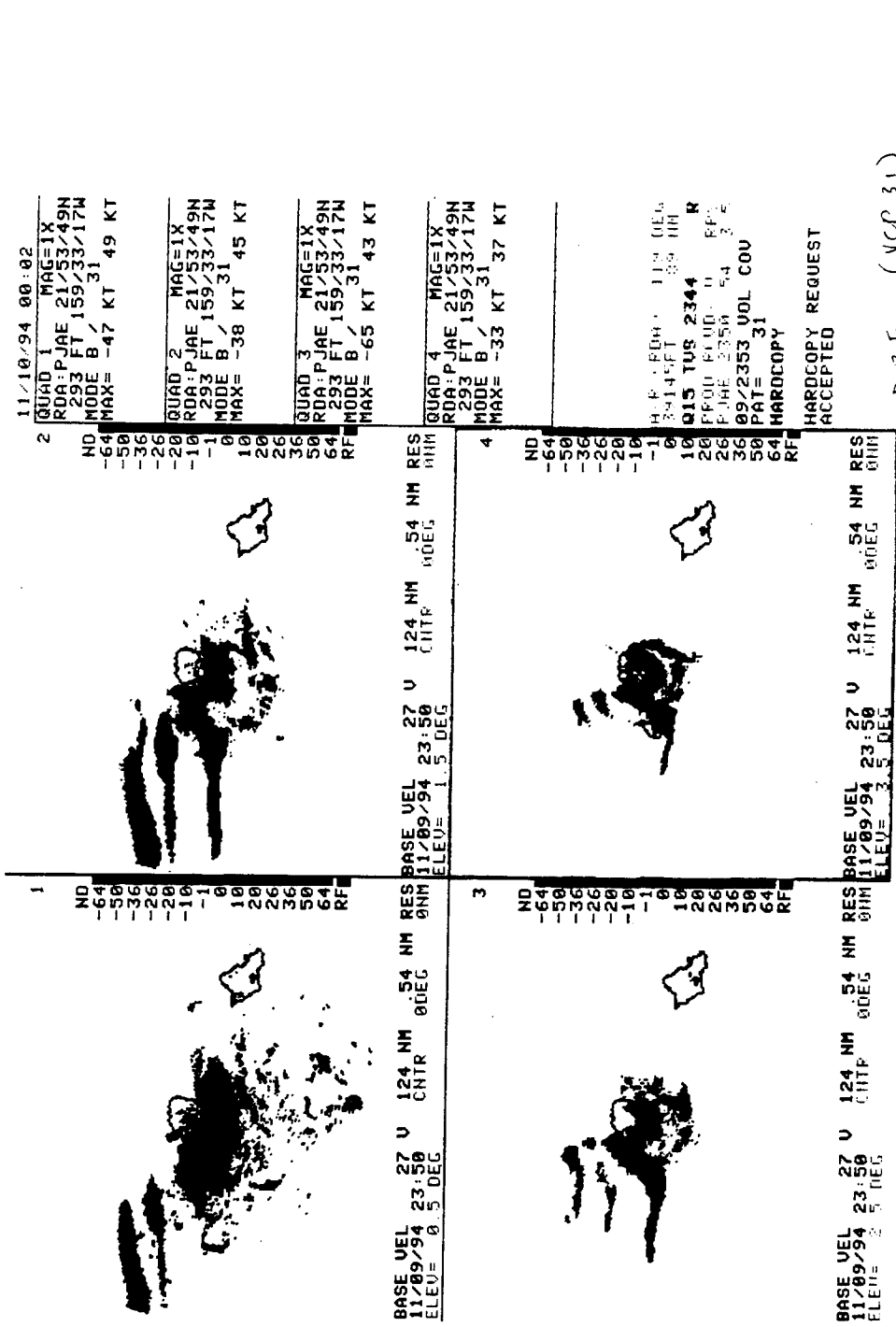
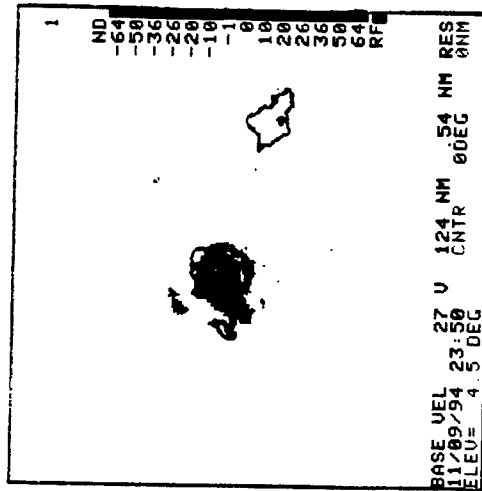

FIGURE A-9. TEST D-25, CLEAR AIR MODE VERIFICATION TEST. South Kauai provides weather data (base velocity) for elevation angles 0.5°, 1.5°, 2.5°, and 3.5°. Elevation angles appear on third line of text of each quadrant.



11/10/94 08:05  
 QUAD I MAG=IX  
 RDA:PJAE 21/53/49N  
 293 FT 159/33/17W  
 MODE B / 31  
 MAX= -34 KT 31 KT

H P R 114  
 015 U 2350 R  
 PROD KODD OHF REP  
 FJHE HMMB  
 09/2353 UOL COV  
 PAT= 31  
 HARDCOPY  
 HARDCOPY REQUEST  
 ACCEPTED

D 25 (VCP 31)  
 2/2

FIGURE A-10. TEST D-25, CLEAR AIR MODE VERIFICATION TEST. South Kauai provides weather data (base velocity) for elevation angle 4.5°. Elevation angle appears on third line of text of quadrant.

**Test:** D-26, Frequency Verification Test

**Test Objective/  
Evaluation Criteria:** Verify that each channel of the FAA redundant configuration operates within the 2.7 - 3.0 GigaHertz (GHz) frequency bandwidth.

**Test Description:** Output frequency of each channel was measured using Radar Data Acquisition Software Operational Test (RDASOT).

**Data Collection and  
Analysis Method:** For each channel, a Continuous Wave (CW) test signal was injected using RDASOT. While the CW test signal was present, a frequency counter verified the output frequency was within specification. Test Comments/Notes Sheet #9.

**Test Results:** Tests verified that the frequency of both radar transmitters was within operating tolerance. During the test period at Kauai, channel 1 operated at 2.76 GHz and channel 2 at 2.77 GHz.

**Service Reports  
Generated:** None

**COIs Addressed:** N/A

**Test:** D-27, Request Time Verification Test

**Test Objective/  
Evaluation Criteria:** Verify that the FAA redundant configuration can accept a maximum of three requests per second for weather products.

**Test Description:** Test team communication was established to three PUPs. The PUP operators simultaneously requested a single weather product. This test was conducted on both channels.

**Data Collection and  
Analysis Method:** ACW-200 received verbal confirmation of product receipt from the PUP operators. UCP system status log printouts showing the narrow band line connections were collected.

**Test Results:** ACW-200 and NWS successfully verified that the redundant configuration can accept a maximum of three requests per second for weather products. The Molokai, Hickam Air Force Base, and Pearl Harbor PUPs, using their dial-in capability, simultaneously requested and received Kauai NEXRAD weather products.

**Service Reports  
Generated:** None

**COIs Addressed:** N/A

**Test:** D-28, Response Time Verification Test

**Test Objective/  
Evaluation Criteria:** Verify that the FAA redundant configuration can respond within 3 seconds after receipt of a request for weather products.

**Test Description:** For each channel, product requests were made to the PUP. The test team member making the request measured the time it took for the PUP to respond to the request.

**Data Collection and  
Analysis Method:** The NWS meteorologist requested weather products from the PUP graphics tablet, and subsequently received that product. PUP plots were collected and examined.

**Test Results:** ACW-200 and NWS successfully verified that the redundant configuration can respond within 3 seconds (actual time: approximately 1 second) after a request for varied weather products (base reflectivity, velocity, spectrum width, echo tops, 3-hour precipitation).

**Service Reports  
Generated:** None

**COIs Addressed:** N/A

**Test:** D-29, Alarm/Alert Time Verification Test

**Test Objective/  
Evaluation Criteria:** Verify that the FAA redundant configuration can generate an alarm/alert within 5.0 seconds from detection of an alarm condition.

**Test Description:** This test was accomplished during D-8, Degraded Operations testing. The time was recorded each time a fault was inserted in the equipment. The time of response to the fault was measured at the UCP and the RDA maintenance terminal.

**Data Collection and  
Analysis Method:** Test Comments/Notes Sheet #17, #19, #20, #21, #22, #23.

**Test Results:** The requirement for 5 second detection of a failure condition was achieved in most cases. In the cases that took over 5 seconds to detect the failure, it was determined by the test team the additional time required for an operator to detect the failure was not critical. This was primarily due to the fact that, during the degraded operations testing, corrupted data was not output from the radar. If the radar did send corrupted data to the operator, it was tagged with an alarm to identify a fault condition.

**Service Reports  
Generated:** None

**COIs Addressed:** N/A

**Test:** D-30, Weather Intensity Test

**Test Objective/  
Evaluation Criteria:** Verify that the FAA redundant configuration can categorize weather into six levels of intensity. Intensity is in magnitude of reflectivity (dBz).

**Test Description:** For each channel verify that the FAA redundant configuration can categorize weather into six levels of intensity.

**Data Collection and  
Analysis Method:** The NWS meteorologist requested six levels of precipitation intensity from the PUP graphics tablet, and subsequently received those precipitation levels. PUP plots were collected and examined.

**Test Results:** ACW-200 and NWS successfully verified that the redundant configuration can categorize weather (reflectivity) into six levels of intensity, as specified in Test Procedure D-30. Refer to figure A-11.

**Service Reports  
Generated:** None

**COIs Addressed:** N/A

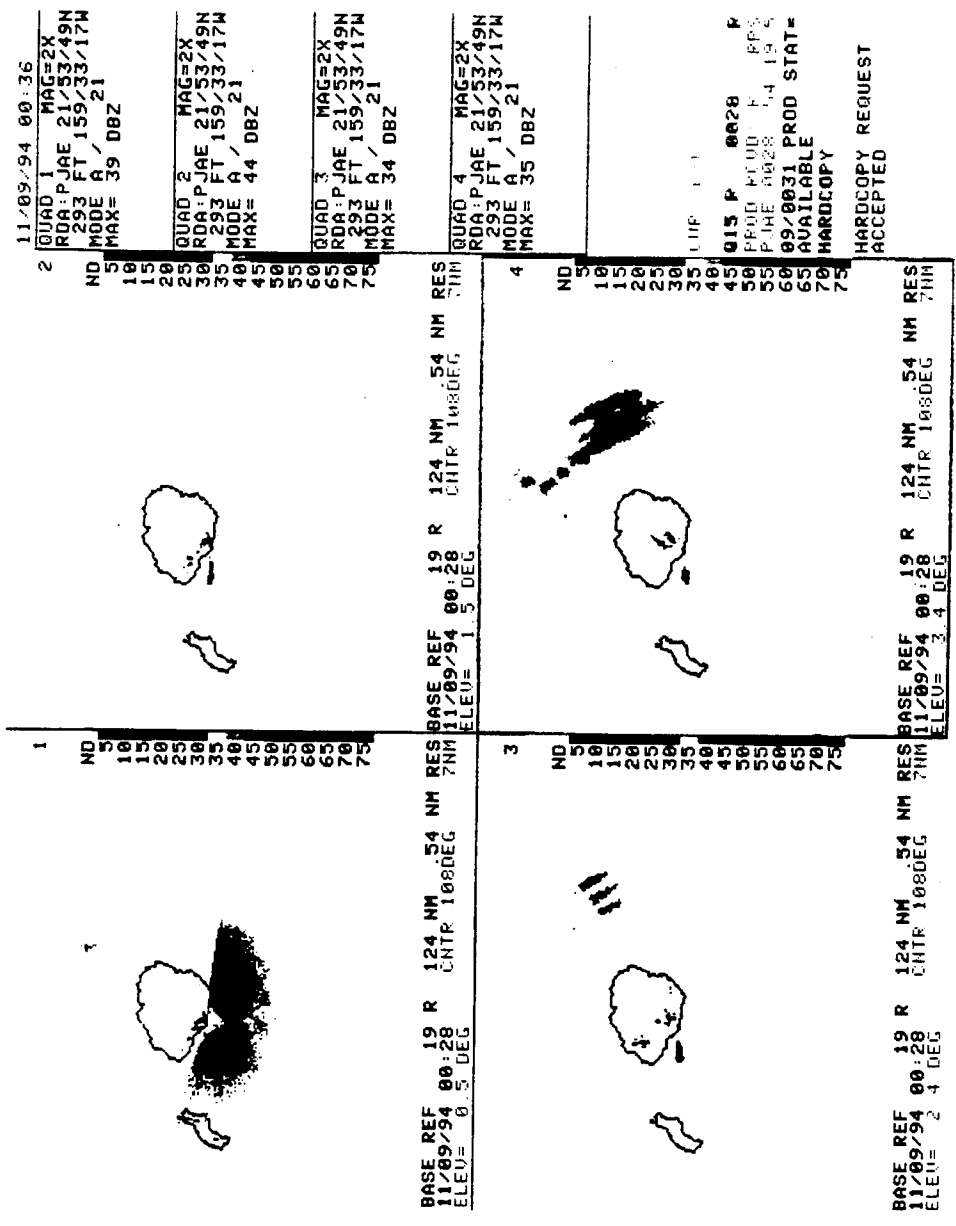

FIGURE A-11. TEST D-30, WEATHER INTENSITY VERIFICATION TEST. South Kauai PUP provides capability to categorize base reflectivity into at least 6 levels of intensity. Sixteen intensity levels are present along the right side of each quadrant.

**Test:** D-31, Reflectivity Display Threshold Verification Test

**Test Objective/  
Evaluation Criteria:** Verify that the FAA redundant configuration shall not display reflectivity intensity values for a threshold level less than 18 dBz.

**Test Description:** For each channel, the reflectivity threshold level for displayed reflectivity was set to 18 dBz or greater, at the PUP. Reflectivity products were selected and it was verified that products below the 18 dBz threshold were not displayed.

**Data Collection and  
Analysis Method:** The NWS meteorologist requested from the PUP graphics tablet that reflectivity intensities of 18 dBz and lower not be displayed, and subsequently received visual confirmation. PUP plots were collected and examined.

**Test Results:** ACW-200 and NWS successfully verified that the redundant configuration does not display reflectivity intensity for a threshold level less than 18 dBz when requested not to display it. Refer to figure A-12.

**Service Reports  
Generated:** None

**COIs Addressed:** N/A

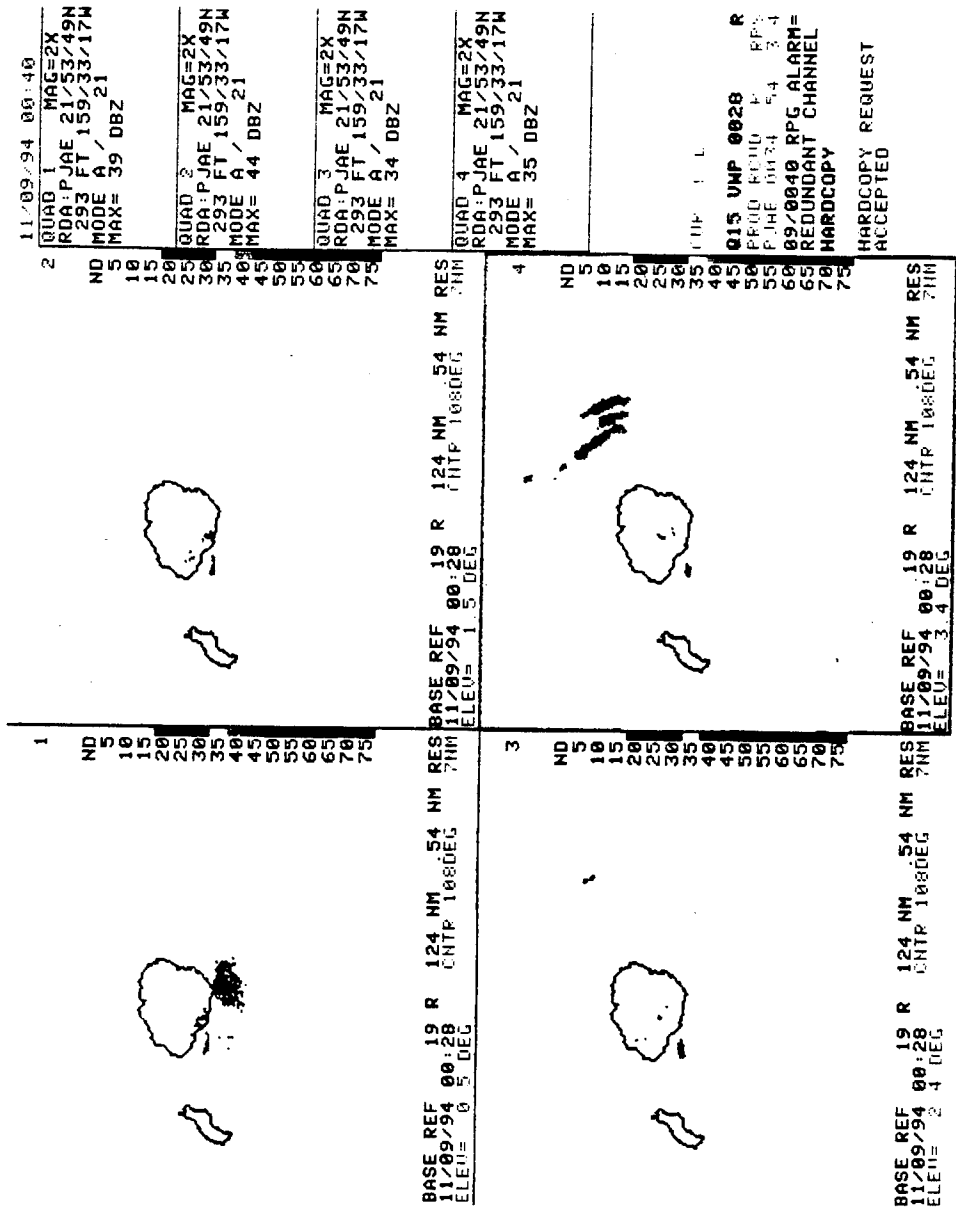

D-31  
6, 2

FIGURE A-12. TEST D-31, REFLECTIVITY DISPLAY THRESHOLD VERIFICATION TEST. South Kauai PUP provides the capability to blank intensity level of 18 dBz and lower. Intensity levels are present along the right side of each quadrant. Refer to FIGURE A-11 for data with 16 intensity levels present. Times of data for FIGURE A-11 and FIGURE A-12 are 00:36 and 00:40, respectively.

**Test:** D-32, Offshore NEXRAD Inherent Availability (Ai) Test

**Test Objective/  
Evaluation Criteria:** Verify that the FAA redundant configuration does possess an Ai of 0.99987616.

**Test Description:** Ai of the system was calculated based on the failure data collected from the ACW OT&E test period as well as preliminary failure data from AOS Shakedown testing as of January 20, 1995.

**Data Collection and  
Analysis Method:** Critical failure data was collected during the test periods. The data was analyzed and an MTBF figure was generated using the ACW software program "MTBF." The software developed for this task is based on MIL-HDBK-781. The MTTR was then combined with this MTBF figure, per the test procedures, to generate an Ai figure.

**Test Results:** Actual Ai measured during the ACW OT&E test period and preliminary AOS failure data as of January 20, 1995, indicate an Ai of 0.99644659. This is significantly below the NAS-SS-1000 specification of 0.99987616. These figures are based on critical failures only, in an ideal support and logistics environment. Detailed recommendations to improve Ai of the system are discussed in section 7 of this report.

**Service Reports  
Generated:** Refer to the Service Report Summary in section 5.

**COIs Addressed:** MOS A-1

**Test:** D-33, Offshore NEXRAD Mean Time Between Failures (MTBF) Test

**Test Objective/  
Evaluation Criteria:** Verify that the FAA redundant configuration does possess an MTBF of 4037 hours.

**Test Description:** MTBF of the system was calculated based on the failure data collected from the ACW OT&E test period as well as preliminary failure data from AOS Shakedown testing as of January 20, 1995.

**Data Collection and  
Analysis Method:** Critical failure data was collected during the test periods, including preliminary AOS data as of January 20, 1995. The data was analyzed and an MTBF figure was generated using the ACW software program "MTBF." The software developed for this task is based on MIL-HDBK-781.

**Test Results:** An analysis critical failure data only, yielded the following, based on a sample size of about 1670 hours during which eight critical failures occurred:

The MTBF is 209 hours. Per MIL-HDBK-781 we have a 95 percent confidence level that the system MTBF is between 116 hours and 484 hours. This figure is a measure of how long the system will run before a critical failure occurs (i.e., the system goes off-the-air). It is a measure of the system's performance and is independent of the operational environment at Kauai, HI.

The NAS-SS-1000 specification is 4037 hours; therefore, the system does not meet NAS-SS-1000 specification.

The figures mentioned above do not identify the overall MTBF of the system for critical and noncritical failures. During ACW's OT&E test period, critical

and noncritical failures occurred. The overall (including critical and non-critical) MTBF for the Kauai NEXRAD per year will be much lower than the MTBF for critical failures only. Recommendations to improve reliability are provided in section 7 of this report.

**Service Reports  
Generated:**

Refer to the Service Reports Summary in section 5.

**COIs Addressed:**

MOS A-1, MOS A-3

**Test:** D-34, Offshore NEXRAD Mean Time To Repair (MTTR) Test

**Test Objective/  
Evaluation Criteria:** Verify that the FAA redundant configuration does possess an MTTR of 0.5 hours.

**Test Description:** MTTR of the system was calculated based on the failure data collected from the ACW OT&E test period as well as preliminary failure data from AOS Shakedown testing as of January 20, 1995.

**Data Collection and  
Analysis Method:** Critical failure data was collected during the test periods. The data was analyzed and an MTTR figure was generated.

**Test Results:** Actual MTTR measured during the test periods indicated an MTTR of 0.7 hours. This is below NAS-SS-1000 specification of 0.5 hours. These figures are based on critical failures only, in an ideal support and logistics environment. Although the figure of 0.7 hours is close to specification, it is important to note that the test data is somewhat skewed. Of the eight critical failure data points, at least five are related to unknown causes and/or power related failures. In these instances, the repair of the failure involved executing power off and power on commands to reset the system. Resetting the system in this manner required typically 10 to 30 minutes. Performing resets in this manner, when no other corrective maintenance action was known, had a net result of lowering the true MTTR figure. Detailed recommendations to improve the reliability of the system are discussed in section 7 of this report.

**Service Reports  
Generated:** Refer to the Service Report Summary in section 5.

**COIs Addressed:** MOS A-2, MOS A-3