



**US Army Corps
of Engineers**

Construction Engineering
Research Laboratories

USACERL Technical Report FE-95/10
February 1995

Air Cleaning Systems and Indoor Air Quality: A Review

by
William T. Brown, III
Glen A. Chamberlin
Jerry M. LaGrou

Indoor air quality has an impact on the health and productivity of building occupants and is an important consideration in buildings used by the U.S. Army. The demand for improvements in indoor air quality increases as more is known about how particulate and gaseous contaminants affect human health. There are no universal guidelines for the designing and the operation and maintenance of air cleaning systems, and no U.S. Army Corps of Engineers (USACE) guidance specifically addresses these problems.

Indoor air quality can be improved by bringing in more outdoor air; however, the outdoor air must be relatively clean. Air filtration systems also can be improved/increased, although energy consumption may increase. Air filters are installed to protect equipment from large particulates in the air; and they now are being considered an efficient method for protecting human health in office buildings by reducing the contaminants in indoor air.

The state of the art of air filtration, including health issues, regulations, standards, guidelines, designs, and specifications, was examined. Current research on air filtration technologies and issues and future air filtration needs also were examined. Regulations on indoor air quality were reviewed to establish gaps in data and begin attempts to set uniform guidelines.

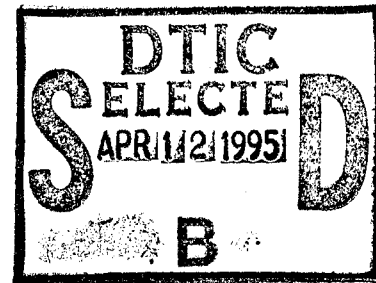

19950410 041

The contents of this report are not to be used for advertising, publication, or promotional purposes. Citation of trade names does not constitute an official endorsement or approval of the use of such commercial products. The findings of this report are not to be construed as an official Department of the Army position, unless so designated by other authorized documents.

DESTROY THIS REPORT WHEN IT IS NO LONGER NEEDED

DO NOT RETURN IT TO THE ORIGINATOR

USER EVALUATION OF REPORT

REFERENCE: USACERL Technical Report FE-95/10, *Air Cleaning Systems and Indoor Air Quality: A Review*

Please take a few minutes to answer the questions below, tear out this sheet, and return it to USACERL. As user of this report, your customer comments will provide USACERL with information essential for improving future reports.

1. Does this report satisfy a need? (Comment on purpose, related project, or other area of interest for which report will be used.)

2. How, specifically, is the report being used? (Information source, design data or procedure, management procedure, source of ideas, etc.)

3. Has the information in this report led to any quantitative savings as far as manhours/contract dollars saved, operating costs avoided, efficiencies achieved, etc.? If so, please elaborate.

4. What is your evaluation of this report in the following areas?

a. Presentation: _____

b. Completeness: _____

c. Easy to Understand: _____

d. Easy to Implement: _____

e. Adequate Reference Material: _____

f. Relates to Area of Interest: _____

g. Did the report meet your expectations? _____

h. Does the report raise unanswered questions? _____

i. General Comments. (Indicate what you think should be changed to make this report and future reports of this type more responsive to your needs, more usable, improve readability, etc.)

5. If you would like to be contacted by the personnel who prepared this report to raise specific questions or discuss the topic, please fill in the following information.

Name: _____

Telephone Number: _____

Organization Address: _____

6. Please mail the completed form to:

Department of the Army
CONSTRUCTION ENGINEERING RESEARCH LABORATORIES
ATTN: CECER-IMT
P.O. Box 9005
Champaign, IL 61826-9005

REPORT DOCUMENTATION PAGE

Form Approved
OMB No. 0704-0188

Public reporting burden for this collection of information is estimated to average 1 hour per response, including the time for reviewing instructions, searching existing data sources, gathering and maintaining the data needed, and completing and reviewing the collection of information. Send comments regarding this burden estimate or any other aspect of this collection of information, including suggestions for reducing this burden, to Washington Headquarters Services, Directorate for information Operations and Reports, 1215 Jefferson Davis Highway, Suite 1204, Arlington, VA 22202-4302, and to the Office of Management and Budget, Paperwork Reduction Project (0704-0188), Washington, DC 20503.

1. AGENCY USE ONLY (Leave Blank)		2. REPORT DATE February 1995	3. REPORT TYPE AND DATES COVERED Final	
4. TITLE AND SUBTITLE Air Cleaning Systems and Indoor Air Quality: A Review			5. FUNDING NUMBERS 4A162784 AT45 FE-X34	
6. AUTHOR(S) William T. Brown, III, Glen A. Chamberlin, and Jerry M. LaGrou				
7. PERFORMING ORGANIZATION NAME(S) AND ADDRESS(ES) U.S. Army Construction Engineering Research Laboratories (USACERL) P.O. Box 9005 Champaign, IL 61826-9005			8. PERFORMING ORGANIZATION REPORT NUMBER FE-95/10	
9. SPONSORING / MONITORING AGENCY NAME(S) AND ADDRESS(ES) U.S. Army Center for Public Works ATTN: CECPW-EM 7701 Telegraph Road Alexandria, VA 22310-3862			10. SPONSORING / MONITORING AGENCY REPORT NUMBER Headquarters, U.S. Army Corps of Engineers ATTN: CEMP-ET 20 Massachusetts Ave., NW Washington, DC 20314-1000	
11. SUPPLEMENTARY NOTES Copies are available from the National Technical Information Service, 5285 Port Royal Road, Springfield, VA 22161.				
12a. DISTRIBUTION / AVAILABILITY STATEMENT Approved for public release; distribution is unlimited.			12b. DISTRIBUTION CODE	
13. ABSTRACT (Maximum 200 words) <p>Indoor air quality has an impact on the health and productivity of building occupants and is an important consideration in buildings used by the U.S. Army. The demand for improvements in indoor air quality increases as more is known about how particulate and gaseous contaminants affect human health. There are no universal guidelines for the designing and the operation and maintenance of air cleaning systems, and no U.S. Army Corps of Engineers (USACE) guidance specifically addresses these problems.</p> <p>Indoor air quality can be improved by bringing in more outdoor air; however, the outdoor air must be relatively clean. Air filtration systems also can be improved/increased, although energy consumption may increase. Air filters are installed to protect equipment from large particulates in the air; and they now are being considered an efficient method for protecting human health in office buildings by reducing the contaminants in indoor air.</p> <p>The state of the art of air filtration, including health issues, regulations, standards, guidelines, designs, and specifications, was examined. Current research on air filtration technologies and issues and future air filtration needs also were examined. Regulations on indoor air quality were reviewed to establish gaps in data and begin attempts to set uniform guidelines.</p>				
14. SUBJECT TERMS indoor air quality air filtration			15. NUMBER OF PAGES 80	
			16. PRICE CODE	
17. SECURITY CLASSIFICATION OF REPORT Unclassified	18. SECURITY CLASSIFICATION OF THIS PAGE Unclassified	19. SECURITY CLASSIFICATION OF ABSTRACT Unclassified	20. LIMITATION OF ABSTRACT SAR	

Foreword

This study was conducted for the U.S. Army Center for Public Works (USACPW) and the Directorate of Military Programs, Headquarters, U.S. Army Corps of Engineers (HQUSACE) under Project 4A162784AT45, "Military Energy Conservation Technology"; Work Unit FE-X34, "Energy Systems Technology for Indoor Air Quality." The USACPW technical monitor was Chris Irby, CECPW-EM; the HQUSACE technical monitor was Frank Meisel, CEMP-ET.

The work was performed by the Energy and Utility Systems Division (FE) of the Infrastructure Laboratory (FL), U.S. Army Construction Engineering Research Laboratories (USACERL). The USACERL principal investigator was Glen A. Chamberlin. Dr. David M. Joncich is Chief, CECER-FE, and Alan Moore is Acting Chief, CECER-FL. The USACERL technical editor was Agnes E. Dillon, Information Management Office.

LTC David J. Rehbein is Commander and Acting Director of USACERL, and Dr. Michael J. O'Connor is Technical Director.

Accession For	
NTIS GRA&I	<input checked="" type="checkbox"/>
DTIC TAB	<input type="checkbox"/>
Unannounced	<input type="checkbox"/>
Justification	
By	
Distribution/	
Availability Codes	
Dist	Avail and/or Special
A-1	

Contents

SF 298	1
Foreword	2
List of Tables and Figures	5
1 Introduction	7
Background	7
Objectives	8
Approach	8
Mode of Technology Transfer	8
2 Particulate Filtration	9
Health and Comfort Issues Concerning Particulates	9
Regulations and Codes on Air Particulate Size and Concentrations	11
Particulate Filter Design Guidance	15
Current AHU Filtering Technologies for Particle Filters	16
Particulate Filter Requirements and Specifications	21
Standards for Determining and Measuring Particulate Filter Performances	25
3 Gas-Phase Filtration	31
Health and Comfort Issues Concerning Gaseous Contaminants	31
Regulations and Codes on Gaseous Contaminant Concentrations	35
Gas-Phase Filter Design Guidance	38
Current AHU Filtering Technologies for Gas-Phase Filtration	39
Gas-Phase Filter Requirements and Specifications	42
Standards for Determining and Measuring Gaseous Filter Performances	44
4 Developing AHU Filtering Technologies	45
Drum Filtration	45
Composite Medium for HEPA Filters	46
Electric HEPA Filters	46
Metal-Fiber Deep Bed Filters	47
Glass-Fiber Deep Bed Filters	47
Stacked-Disc Filters	47
Integrated Air Purifier	48

5	Research and Other Developments in Filtration	49
	Fractional Efficiency Test Method	49
	Indoor Air Pollution Abatement Process	49
	New Filter Selection Methodology	50
	Universal Air Filter Classification System	50
	Replacement Materials for DOP Testing	51
	Current ASHRAE Research Projects	51
6	Conclusion	52
	Metric Conversion Factors	53
	References	54
	Appendix A: Specifications Relating to Particulate Filtration	59
	Appendix B: Specifications Relating to Gas-Phase Filtration	72
	Appendix C: Research Projects	74
	Abbreviations and Acronyms	76
	Distribution	

List of Tables and Figures

Tables

1	OSHA standard values—particulates	13
2	ASHRAE values—particulates	15
3	Particulate filter types and selective ratings	24
4	National Primary and Secondary Ambient Air Quality Standards—gaseous contaminants	35
5	OSHA standard values—gaseous contaminants	36
6	ASHRAE standards—gaseous contaminants	37
7	Gaseous concentration levels in Illinois	38
8	Gases and respective removal media	43
9	Gas-phase types and characteristics	44
10	Universal air filter classes	51
A1	Initial pressure drop of air extended media area type filters	61
A2	Final pressure drop of air extended media area type filters	61
A3	Air extended media area type filter efficiencies	62
A4	Initial pressure drop of Type I and II air-extended area filters	64
A5	Final pressure drop of Type I and II air-extended area filters	65
A6	Average synthetic dust weight arrestance of Type I and II air-extended area filters (in percent)	65
A7	Average dust spot efficiency for Type I and II air-extended area filters	65

A8	Average dust holding capacity for Type I and II air-extended area filters (in grams)	65
A9	Initial pressure drop for Type III air-extended area filters	66
A10	Final pressure drop of Type III air-extended area filters	66
A11	Efficiency of Type III air-extended area filters	66

Figures

1	ASHRAE air filter test duct	27
2	Final filter in disposable cartridge form	28

1 Introduction

Background

Indoor air quality (IAQ) is an important consideration in the design of Army buildings because of its impact on the health and productivity of building occupants. Four technologies address the removal of air contaminants:

- particulate filtration, which removes materials with a size, shape, or mass that allows them to remain airborne at the air velocity conditions in the room
- electrostatic precipitation, which collects airborne particulates by the attraction of charged particles to oppositely charged surfaces
- negative ion generation, which removes particles from indoor air by static charges
- gas sorption, which controls compounds that behave as gases rather than as particles.

The first three technologies deal with the removal of particulates; the last technology is used solely in removing gases. These technologies work in such a diverse manner that no current set of standards pertains to all of them; but a number of organizations have attempted to establish standards or guidelines for ventilation systems.

A ventilation standard by the American Society of Heating, Refrigerating and Air-Conditioning Engineers (ASHRAE) (1990, p 1) is recognized by the U.S. Environmental Protection Agency (USEPA) as the only comprehensive guideline for controlling IAQ in occupied spaces (Fencl, September 1993, p 14). ASHRAE Standard 62-1989 (1990, p 9) states that the treatment of outdoor air should be accomplished by air-cleaning systems suitable for particles, gases, and vapors if outdoor air contaminant levels exceed the National Ambient Air Quality Standards (NAAQS). Currently there are no universal design or retrofit guidelines on heating, ventilating, and air-conditioning (HVAC) air filtration systems because of the immense variety of filters and their respective applications and design specifications. Central-station air handling units (AHU) are an important portion of HVAC systems because filters normally are installed in the AHU. Although the Corps of Engineers Guide Specification (CEGS) 15895 (September 1993) contains specifications for primary HVAC air filters, no U.S. Army Corps of Engineers (USACE) guidance has been documented specifically on the

process to determine the filter performance requirements. More detailed application guidelines on air cleaning devices that expand on ASHRAE Standard 62-1989 (1990) are needed.

Objectives

This report is the first step in research to improve indoor air quality in buildings used by the U.S. Army through the improvement of air filtration. The objective of this report is to review AHU air-cleaning technology as it pertains to IAQ, particularly in connection with AHU components and HVAC systems, to determine gaps in knowledge and research needs. The ultimate objective of this part of the IAQ program at the U.S. Army Construction Engineering Research Laboratories (USACERL) is to improve air-cleaning technologies and guidance documents of the USACE to enhance IAQ in buildings used by the U.S. Army.

Approach

A literature search was conducted to determine existing AHU filtering technologies, those technologies under development, and current USACE and other guidance on AHU filtering and filter testing. Current literature also was reviewed to examine basic indoor air quality health and comfort issues regarding particulates and gases, followed by the regulations and codes governing acceptable concentrations.

Mode of Technology Transfer

Information from this project will be incorporated into CEGS-15895 (*Air Supply and Distribution System for Air-Conditioning System*), CEGS-15935 (*Ventilation and Exhaust Systems*), TM 5-810-1 (*Mechanical Design--Heating, Ventilation, and Air-Conditioning*), and *Architectural and Engineering Instructions--Design Criteria* (AEI). Information also will be incorporated into four Proponent Sponsored Engineer Corps Training (PROSPECT) courses, conducted by USACE: Course No. 391, *Basic HVAC Design*; Course No. 340, *Design of Standard HVAC Control Systems*; Course No. 382, *Quality Verification of Standard HVAC Control Systems*; and Course No. 327, *Commissioning of Mechanical Systems*. Articles will be published in the *Public Works Digest* and other journals. And presentations are planned for USACE and other military meetings.

2 Particulate Filtration

ASHRAE (1990, p 3) defines acceptable IAQ as "air in which there are no known contaminants at harmful concentrations as determined by cognizant authorities and with which a substantial majority (80 percent or more) of the people exposed do not express dissatisfaction." This ASHRAE standard also states (1990, p 12), "Properly cleaned air must be recirculated....The air-cleaning used to clean recirculated air should be designed to reduce particulate and, where necessary and feasible, gaseous contaminants."

Health and Comfort Issues Concerning Particulates

Hansen (1991, p 242) defines particulate matter as "a state of matter in which solid or liquid substances exist in the form of aggregated molecules or particles." Particulates can be classified best into three major categories: (1) respirable particulates, (2) fibers (particularly asbestos), and (3) bioaerosols. These categories and the health and comfort issues associated with each will be discussed in detail.

Respirable Particulates

Respirable particulates, which are defined in size as 10 micrometers (μm) or less, serve as carriers for such contaminants as pesticides, polychlorinated biphenyls, radon daughters, and pathogens, thereby delivering harmful substances to vulnerable areas. "Size," according to Hansen, "determines the magnitude of risk and the ultimate location in the lungs. Since smaller particles are breathed deeper into the lungs, they can by-pass respiratory defense mechanisms thereby creating a greater health hazard" (Hansen 1991, p 66).

Common sources of respirable particulates include environmental tobacco smoke, kerosene heaters, humidifiers, wood stoves, and fireplaces. Respirable particulates can be categorized into two parts: (1) biological particles, including microbial particles, which may give off harmful organic gases in the air; and (2) nonbiological particles, such as dust and dirt, which are brought in on clothing and can come from activities, maintenance products, and the natural decay of building products and furnishings.

Hansen (1991, pp 66-67) cited the following concerns relating to respirable particulates: "(1) chemical or mechanical irritation of tissues, including nerve endings at the site of deposition, (2) impairment of respiratory mechanics, (3) aggravation of existing respiratory or cardiovascular diseases, (4) reduction in particle clearance and other host defense mechanisms, (5) impact on host immune system, (6) morphologic changes of lung tissues, and (7) carcinogenesis." The USEPA has noted that respirable particles at concentrations of 250 to 350 $\mu\text{g}/\text{m}^3$ increase respiratory symptoms in compromised individuals (Hansen 1991, p 67). According to Offermann and his ASHRAE colleagues (Offermann, Loiselle, and Sextro, July 1992, p 51), "Environmental tobacco smoke particles are liquid droplets of condensed tobacco combustion vapors that contain numerous organic compounds including known and suspected carcinogens and tumor promoters. It is the particulate phase of tobacco smoke that is suspected of causing lung cancer."

Whenever indoor concentrations of respirable particulates are greater than outdoor concentrations, one effective, yet expensive, control technique is dilution with outdoor air. Another technique is recirculation, allowing a portion of the outdoor air to be mixed with the indoor air, then reconditioning the air within the ventilation system. "Recirculated air must be diluted or treated, or particle concentrations will increase as long as the source is producing" (Hansen 1991, p 282).

Asbestos

The most commonly used asbestos is chrysotile, a serpentine material, which accounts for 95 percent of the asbestos used in buildings in the United States. Amphiboles (including amosite and crocidolite) are the second largest asbestos type. Each type has its own fiber structure and associated health risks. When the asbestos is in place, it does not spontaneously degenerate. Unless a substantial amount of mechanical external force is applied, fiber bundles are not inclined to be disrupted.

Sources of asbestos can be found in reinforced cement, heat-resistant textiles, boiler insulations, pipe insulations, sprayed-on fire proofing, breaching insulation, and floor and ceiling tiles. Excluding schools and residential buildings with less than 10 units, 20 percent (or 733,000) of the buildings in the United States contain friable asbestos, according to USEPA estimates (Hansen 1991, p 57). The USEPA and medical specialists also estimate that, within the next 30 years, 1000 to 7000 people already exposed to asbestos will die of asbestos-related diseases (Hansen 1991, p 57). "Three forms of disease have been associated with the inhalation of asbestos fibers: (1) asbestos-fibrosis or scarring of the lungs; (2) mesothelioma--a malignancy of the linings of the lung and abdomen; and (3) lung cancer" (Hansen 1991, p 57).

Bioaerosols

Airborne biological agents, called bioaerosols, include fungi (yeasts and molds), dander, spores, pollen, insect parts and feces, bacteria, and viruses. Sources of biological agents include wet insulation, carpet, ceiling tile, wall coverings, furniture, and stagnant water in air-conditioners, dehumidifiers, humidifiers, cooling towers, and drip pans and cooling coils of AHU. Fiberglass insulation, primarily substituted for asbestos, can become a breeding ground for bioaerosols.

Concern is also increasing about how dirty ductwork becomes a growing area for biological contaminants. Burge (1987, p 34) explains, "Fiberglass-lined ductwork cannot be effectively cleaned if mold growth on the fiberglass itself has occurred (as opposed to dust and spore accumulation). Microbiologically, fiberglass exposed to humid air in the supply airstream is not a good idea. Fiberglass lining should not be used in areas of high humidity or where water air washers are part of the system."

Common symptoms associated with bioaerosols are: sneezing, watery eyes, coughing, shortness of breath, dizziness, lethargy, fever, and digestive problems. Hypersensitivity diseases such as asthma, humidifier fever, and hypersensitivity pneumonitis frequently are caused by "immunological sensitization to bioaerosols" (Hansen 1991, p 59).

Regulations and Codes on Air Particulate Size and Concentrations

Regulating the acceptable limits on size and concentrations of air particulates is dependent on Federal, state, or military guidelines that apply to certain businesses, industries, and other indoor facilities. Current guidelines are discussed here in three parts: (1) Federal regulations, (2) military regulations, and (3) state regulations.

Federal Regulations and Codes

National Primary and Secondary Ambient Air Quality Standards. The USEPA has defined levels of air quality using National Primary and Secondary Ambient Air Quality Standards under Section 109 of the Clean Air Act (CAA). According to the Code of Federal Regulations (40 CFR 50.6(c)): "particulate matter shall be measured in the ambient air as PM₁₀ (particles with an aerodynamic diameter less than or equal to a nominal 10 micrometers)." Section 50.6 is the standard reference for determining acceptable levels of particulate matter. Under the National Ambient Air Quality Primary and Secondary Standards, levels for particulate matter should not exceed 150 $\mu\text{g}/\text{m}^3$ for 24-hour average concentration and 50 $\mu\text{g}/\text{m}^3$ for the annual arithmetic mean (40 CFR 50.6(c)).

American Conference of Governmental Industrial Hygienists Standards. The American Conference of Governmental Industrial Hygienists (ACGIH) annually publishes documentation on threshold limit values (TLVs) of chemical substances. The TLVs are presented in the form of time-weighted averages (TWAs), which are defined as average exposure concentrations for a normal 8-hour workday and a 40-hour workweek (ACGIH, 1994, p iv). A guide to occupational exposure values (ACGIH, 1994, p i) "is intended as a companion document to ACGIH's annual *Threshold Limit Values and Biological Exposure Indices* Booklet." Therefore, the reader is advised that this information is updated on an annual basis.

OSHA Standards. The Occupational Safety and Health Administration (OSHA) acceptable standard levels for air contaminants are those in the Code of Federal Regulations (29 CFR 1910.1000). Table 1 gives the particulate substances.

ASHRAE Standards. ASHRAE standards on particulate size and concentration levels (1990, pp 18-19) are summarized in Table 2.

Military Regulations and Codes

U.S. Army Regulations and Codes. The U.S. Army regulations and codes on particulate contaminants (Technical Bulletin MED 502, February 1982, p B-2) specify that the maximum exposure limits for dust, fumes, and mists must be less than 0.05 mg/m^3 for high efficiency filters. According to the Air Pollution Abatement Program (Army Regulation 200-1, May 1990, Chapter 4, Section 4-2 (b)), the CAA "prescribes procedures for improving and maintaining air quality to protect public health and welfare. The CAA and implementing regulations provide the basis for regulating emissions of criteria pollutants and specified hazardous air pollutants from certain major stationary sources." The primary regulatory mechanisms of the CAA (Army Regulation 200-1, May 1990, Chapter 4, Section 4-2 (b)) include the following:

- NAAQS for "criteria" air pollutants (such as particulate matter, PM_{10})
- new source performance standards (NSPS) "applicable to specified major sources (affected facilities) of air pollutants [40 CFR 60]"
- national emission standards for hazardous air pollutants "applicable to specified sources emitting hazardous air pollutants as listed in 40 CFR 61" (such as asbestos)
- "implementation plans by each State to attain and maintain air quality standards"
- "requirements for Federal facilities to comply with Federal, State, and local air pollution laws and regulations" (Army Regulation 200-1, May 1990, Chapter 4, Section 4-2 (b)).

Table 1. OSHA standard values—particulates.

Substance	Adopted Values, TWA* (mg/m ³)
Aluminum, as Al:	
Total dust	15
Respirable fraction	5
Asbestos (variety of forms)	2 fibers/cm ³
Barium sulfate:	
Total dust	15
Respirable fraction	5
Calcium carbonate:	
Total dust	15
Respirable fraction	5
Cellulose:	
Total dust	15
Respirable fraction	5
Coal dust (greater than or equal to 5% SiO ₂), respirable quartz fraction	0.1
Emery:	
Total dust	10
Respirable fraction	5
Grain dust (oat, wheat, barley)	10
Graphite, natural respirable dust	2.5
Lead inorganic, as Pb	0.05
Nuisance (or inert) dust:	
Total dust	15
Respirable fraction	5
Particulates not otherwise regulated:	
Total dust	15
Respirable fraction	5
Portland cement:	
Total dust	10
Respirable fraction	5
Rouge:	
Total dust	10
Respirable fraction	5
Source: 29(CFR)1910.1000, pp 8-17.	
* TWA = time-weighted average.	

(Continued)

(Table 1. Cont'd)

Substance	Adopted Values, TWA (mg/m ³)
Silicate (less than 1% crystalline silica):	
Mica (respirable dust)	3
Soapstone	
Total dust	6
Respirable fraction	3
Talc (containing no asbestos), respirable dust	2
Silicon:	
Total dust	10
Respirable fraction	5
Silicon carbide:	
Total dust	10
Respirable fraction	5
Starch:	
Total dust	15
Respirable fraction	5
Sucrose:	
Total dust	15
Respirable fraction	5
Titanium dioxide:	
Total dust	10
Tungsten, as W:	
Insoluble compounds	5
Soluble compounds	1
Uranium, as U:	
Insoluble compounds	0.2
Soluble compounds	0.05
Vanadium:	
Respirable dust, as V ₂ O ₅	0.05
Vegetable oil mist:	
Total dust	15
Respirable fraction	5
Wood dust, all soft and hard woods, except Western red cedar	5
Zinc oxide:	
Total dust	10
Respirable fraction	5

Table 2. ASHRAE values—particulates.

Pollutant	Standards
Particulates	National Ambient Air Quality Primary Standard: (40 CFR 50.6, 50.7): $75 \mu\text{g}/\text{m}^3$ annual geometric mean; $260 \mu\text{g}/\text{m}^3$ maximum 24 hours National Ambient Air Quality Secondary Standard: $60 \mu\text{g}/\text{m}^3$ annual geometric mean; $150 \mu\text{g}/\text{m}^3$ maximum 24 hours
Lead dust and fumes	ACGIH ^a , 1986-1987: $0.15 \text{ mg}/\text{m}^3$ 8 hours TLV-TWA ^b
Asbestos	ACGIH, 1986-1987: $0.2\text{-}2.0 \text{ fibers}/\text{cm}^3$ 8 hours TLV-TWA (depending on type of fiber; fibers longer than $5 \mu\text{m}$)

Source: American Society of Heating, Refrigeration, and Air-Conditioning, 1990, pp 18-19. (©1989 American Society of Heating, Refrigerating and Air-Conditioning Engineers, Inc., Atlanta, GA. Used by permission from ANSI/ASHRAE 62-1989.)
^aACGIH = American Conference of Governmental Industrial Hygienists.
^bTLV-TWA = threshold limit value, time-weighted average concentration

USACE Regulations and Codes. Engineer Manual 385-1-1 (October 1992, p 57) specifies general regulations and codes on contaminants: "Exposure to any chemical or physical agent via inhalation, ingestion, skin absorption, or physical contact in excess of the acceptable limits specified in the American Conference of Governmental Industrial Hygienists (ACGIH) Threshold Limit Values and Biological Exposure Indices shall be prohibited." For the use of asbestos at military installations, the Corps of Engineers Guide Specification 15895 (September 1993, Part 2.2) states: "Asbestos and asbestos-containing products shall not be used."

State of Illinois Regulations and Codes

The State of Illinois Air Regulations (Secretary of State, 1992, pp 298-299) cite total suspended particulates to be acceptable at $1 \mu\text{g}/\text{m}^3$ (annual mean concentration) and $5 \mu\text{g}/\text{m}^3$ (24-hour concentration).

Particulate Filter Design Guidance

Technical Manual 5-810-1 (June 1991, p 2-2) specifies filtration design for "administrative facilities, commercial facilities, and similar occupancies where indoor air quality is of primary concern, the combined supply air, including return and outside air, will be filtered by a combination of 25 to 30 percent efficient prefilter(s) and 80 to 85 percent efficient final filter(s) as determined by the dust spot test specified in ASHRAE Standard 52." (See Appendix A for complete excerpt.) ASHRAE 52-1976 has been

superseded by ASHRAE 52.1-1992 as the current air filter standard for removing particulate matter, according to the National Air Filtration Association (NAFA, 1993, p 1.8). "Currently, all major filter manufacturers' literature shows performance in terms of ASHRAE 52-76. As new literature is produced, they will probably reference ASHRAE 52.1-1992. There should be no change in any performance values for the same filter tested by either method" (NAFA 1993, p 7.2).

To effectively use filtration with cleaned, recirculated air, ASHRAE 62-1989 (1990, p 23) specifies, "The amount of outdoor air required depends on the contaminant generation in the space, the contaminant concentrations in the indoor and the outdoor air, the filter location, the filter efficiency for the contaminants in question, the ventilation effectiveness, the supply air circulation rate, and the fraction recirculated." Based on the concept of ASHRAE 62-1989 (1990), a design algorithm has been developed to properly select the appropriate filter efficiency for a desired application, using the following factors: (1) quality of outdoor air for ventilation, (2) quantity of 100 percent outdoor air required to dilute indoor contaminants to acceptable levels, (3) ventilation effectiveness, (4) the reduced outdoor air flow rate required for filtration, and (5) the minimum filter efficiency required (Farr Company 1992, pp 6-11). Improvements could be made to the TM by expanding the details concerning the filter selection process.

NAFA (1993, p ii) has published a comprehensive air filtration manual designed to inform and educate individuals interested in the fundamentals of air filtration, including air filter manufacturers and distributors, professional engineers, facilities managers, HVAC contractors, and others responsible for the design, installation, and maintenance of HVAC systems. This manual also serves as a required document for study to become a NAFA Certified Air Filtration Specialist. "Examinations for NAFA certification are given periodically throughout the year in order to promote quality assurance in connection with the sales and distribution of air filter products and services. The certification examination is based on material in this manual" (NAFA 1993, p ii). According to NAFA (1993, p 1.8), filtration system design can be improved by optimizing three factors: (1) supply air cleanliness, (2) air quantity, and (3) air distribution. Although mathematical and computer modeling can be accomplished to achieve the desired system optimum, the processes are complex.

Current AHU Filtering Technologies for Particle Filters

Filters for particulate matter removal are generally categorized into the following broad types: panel filters, renewable media filters, and electronic air cleaners. Panel

and renewable media filters collect particles through impingement on surfaces; electronic air cleaners use electrostatic attraction to collect particles.

Panel Filters

Panel filters cause the pressure drop to increase up to a certain maximum recommended value because of accumulation in dust load. Categories of panel filters primarily include (Parsons 1992, pp 25.6-25.7): (1) viscous impingement filters are composed of filter media coated with a viscous substance (such as oil) that allows particles which impinge (or strike) on coarse fibers to adhere to those fibers; and (2) dry-type extended surface filters, such as high efficiency particulate air (HEPA), ultra low penetrating air (ULPA), electret, and membrane filters, which use media (composed of bonded glass fiber, cellulose fibers, wool felt, synthetics, and other commercial products) supported by a wire frame in the form of pockets or V-shaped or radial pleats. HEPA and ULPA filters are the most common types of panel filters.

High Efficiency Particulate Air Filters. According to Gupta et al. (July 1993, p 94) "High efficiency particulate air (HEPA) filters are often used as a primary particulate contaminant device in gas cleaning and ventilation systems." (The "A" in HEPA is often used interchangeably for air, aerosol, or arrestor.) The initial pressure drop across an HEPA filter increases because of particulate cake formation on its surface, and the flow rate through the ventilation system decreases with continual buildup of particulate cake. Ideally, the gas flow through the filter approaches zero if there is limitation on the pressure drop (Gupta et al., July 1993, pp 94-95).

Based on studies and tests performed, "...humidity enhances the mass loading capacity of the tested HEPA filter material (glass fiber) for nonhygroscopic and hygroscopic [or moisture-retainable] materials at relative humidities below the deliquescent point [where the particles tend to melt or dissolve at 75 percent Relative Humidity]" (Gupta et al., July 1993, p 106) as a result of the decrease in the specific cake resistance. Furthermore, "The decrease in pressure drop with mass loading [or decrease in cake resistance] at elevated humidities is also dependent on the nature of particles (hygroscopicity) and on deposition patterns which are size dependent" (Gupta et al., July 1993, p 106).

Glass-fiber HEPA filters "were originally developed for military use and were later applied to nuclear facilities for cleaning exhaust gas of hazardous or radioactive particulate" (Brockmann, Adkins, and Gelbard, 1991, p 50). For maximum penetration, conventional HEPA filters are capable of removing particles with sizes ranging between 0.1 and 0.3 μm , depending on the fiber diameter. The flow rate through a clean conventional or high-strength HEPA filter is rated at 1000 cubic feet per minute

(cfm) at 1 inch (in.) of water pressure drop, and the flow rate through a high flow capacity HEPA filter is rated at 1500 cfm at 1 in. of water pressure drop. For dry operation, conventional and high capacity HEPA filters will fail at pressure drops between 16 and 44 in. of water, compared to pressure drops between 8 and 12 in. of water for wet operation. HEPA filters are rated at 99.97 percent removal efficiency (or 0.03 percent penetration) for $0.3 \mu\text{m}$ dioctylphthalate (DOP) particles. The filter design does not account for high mass loading of aerosol (Brockmann, Adkins, and Gelbard, 1991, p 51). Generally, the size of an HEPA filter is a 2 feet (ft) by 2 ft face by about 1 ft deep, with a weight of 40 to 50 pounds (lb) per unit. The effective face velocity for conventional and high-strength filters is 250 feet per minute (fpm), and that of high flow capacity units is 375 fpm. The filter media frequently is impregnated with silicone for water repellency (Brockmann, Adkins, and Gelbard, 1991, p 53).

HEPA filters also are used in indoor firing ranges to remove lead dust. According to O'Rourke (October 1992, p 79) "Manufacturers should rate their filters based on DOP testing performed in accordance with the Army Arsenal Instruction Manual 136-300-175 using cold DOP smoke particles." Although particulate removal effectiveness and ease of installation are among the advantages of the HEPA filter, the disadvantage results from its high static pressure and the need to replace the HEPA filter on a periodic basis. Furthermore, the maximum average cost of an HEPA filter can be 20 percent more expensive than a standard pleated flat filter.

Ultra Low Penetrating Air Filters. ULPA filters have an efficiency in excess of 99.9997 percent of $0.12 \mu\text{m}$ particles, as determined by the DOP test. As is true with HEPA filters, ULPA filters use glass fiber paper technology and "have their lowest removal efficiency at the most penetrating particle size (MPPS), where filter fiber diameter, volume fraction or packing density, and air velocity determine the MPPS" (Parsons 1991, p 16.2). The filters usually are manufactured with deep pleats, using aluminum, coated string, or filter paper as pleating separators. Filter depth ranges from 2 to 12 in. (Parsons, 1991, p 16.2)

Bergman, Biermann, and Sawyer (1990, p 32) state that ULPA filters, used for clean-room applications in semiconductor and electronic industries, have penetrations lower than 0.001 percent. (As is true with HEPA filters, the "A" in ULPA is often used interchangeably for air, aerosol, or arrestor.) HEPA filter test methods no longer are considered to be adequate for extremely low penetration ULPA filters. Because the filters are so efficient, "the medium becomes completely clogged before an appreciable number of particles can penetrate, which leads to a very small working sample" (Bergman, Biermann, and Sawyer, 1990, p 33). Recent testing has shown that replacement of the downstream particle spectrometer (which measures downstream

particle concentrations as a function of size) with a sampling bag reduces the exposure time of the ULPA filter (Bergman, Biermann, and Sawyer, 1990, p 34).

Media Filters

Media filters use a highly efficient filter paper, which is arranged in pleats within a frame. Air cleaning is accomplished by one of the following four types: (1) straining, (2) impaction, (3) interception, or (4) diffusion. In straining, some particles are too large to fit between the holes in the filter fibers and cause the particles to be trapped until thrown away. However, impaction captures some particles small enough to otherwise pass between the "holes" in the filter fibers. In the process, these small particles are constantly being struggled through air turbulence, causing some of the particles to collide with, and stick to, the filter fibers (Energy Management Committee 1989, p 8.4). Interception enables particles to follow the air streamlines and come in contact with the filter fibers as the particles pass around them. Diffusion, often called Brownian movement, occurs when smaller particles do not follow the streamlines and are bombarded by air (or gas) molecules. The particles are then carried along an erratic path, which increases the probability of particles coming into contact with the filter fibers and remaining attached to them (NAFA 1993, p 2.2). The pressure always drops when dirt accumulates in media filters. If the pressure drop exceeds an acceptable limit, the filter must be replaced or the HVAC equipment will be damaged (Energy Management Committee 1989, p 8.4).

In addition to HEPA and ULPA filters, other media filters include the following:

- Replaceable media filters, which introduce fresh media into the airstream to maintain constant resistance and, eventually, constant efficiency. These filters are further classified into (1) automatic moving-curtain viscous impingement filters, and (2) moving-curtain, dry-media filters.
- Extended surface filters, which are based on cartridges consisting of dry or viscous-coated fibrous media formed into pockets or V-shaped pleats supported by wire frames, air-inflated support, or self-support.
- Automatic roll filters, which are of the automatic, motor driven, moving curtain (roll) type with feed control, and involve 2-in. thick, viscous-coated fibrous glass media (General Services Administration, October 1989, pp 4-6).

Electronic Air Cleaners

Electronic air cleaners use the property of electrostatic precipitation to remove and collect dust, smoke, pollen, and other particulate matter. These filters generally

operate at 120 or 240 V on single-phase alternating current capacity (Parsons 1992, p 25.8). SMACNA (Energy Management Committee 1989, p 8.5) classifies electronic air cleaners into three broad types.

- Self-charging mechanical filters: Air rushes through these filters to create an electrostatic charge. Their efficiency is rapidly lowered because of an increase in either relative humidity or air velocity.
- Charged media filters: These filters are created from a dielectric material (in particular, nonconductive fibrous glass or cellulose) stretched across a frame. An electrostatic field is generated by applying a high direct current voltage to the dielectric. However, the electrostatic fields are not strong enough to polarize most particles, thereby reducing effectiveness.
- Two-stage electronic air cleaners: Two-stage electronic air cleaners utilize the following system: (1) an ionizing section in which dirty air particles are passed between ionizing wires connected to a high voltage power supply, and (2) a collections section in which the ionized particles encounter closely spaced, oppositely charged collector plates that allow particles to be simultaneously repelled by positive collector plates and attracted to negative collector plates for collection.

Ozone production is cited as one of the concerns with electronic air cleaners that create a negative corona to charge the particles. Emissions of ozone from commercial air cleaners were generated as a result of the corona current and polarity of the discharge electrode (Viner et al., May/June 1992, p 504). "Manufacturers defend the technology, citing research indicating that ozone levels generated by their equipment remain lower than limits set by standards" (Cutter Information Corporation, August 1991, p 2). The Air-Conditioning and Refrigeration Institute in Arlington, VA, is one manufacturer that includes ozone testing specifications in its standards for both residential and commercial filter equipment (Cutter Information Corporation, August 1991, p 2).

Hansen notes (1991, p 122) that electrostatic air cleaners (EAC) have significantly increased their efficiency in removing particles ranging from the size of 0.01 to 5.0 μm . The collected material must be removed from the collector plates on a regular basis. Operation of EACs is effective when the filter is absolutely clean. In small installations the whole filter has to be removed for washing, but large EACs are designed with wash-in-place capability.

Air Washers

Air washers primarily have been used for special applications such as controlling bacteria growth and humidity, but the dust removal efficiency of air washers mainly

depends on size, density, wettability, and solubility of dust particles (Energy Management Committee 1989, p 8.5). The larger and more wettable the dust particles, the easier removal is. According to ASHRAE (Parsons 1992, p 19.9), "Separation is largely a result of the impingement (or striking) of particles on the wetted surface of the eliminator plates."

Particulate Filter Requirements and Specifications

To properly select the correct particulate filter that meets both the safety needs of HVAC equipment and the health and comfort needs of the building's occupants, certain requirements and specifications must be defined for compliance to Federal, state, and local regulations (i.e., environmental, legal, medical, etc.). Specifications primarily serve to conform to approved public and private standards (such as ASHRAE, American Society for Testing and Materials, Underwriters' Laboratories [UL], etc.).

A specification for filters is generally structured in the following manner:

- scope and classification
- applicable documents
- requirements (including material and component descriptions, manufacture and assembly, performance, and workmanship)
- quality assurance provisions (including certification and performance testing)
- preparation for delivery (including packing and marking)
- notes (including intended use).

A variety of specifications and requirements for effective particulate filters from the Federal level, the military level, ASHRAE standards, and SMACNA standards will be discussed.

Federal Specifications

Information Handling Services, Inc. (IHS) periodically publishes a complete index of military and Federal specifications and standards available on microfilm (Information Handling Services, 1994, pp 610-611). Following is a listing of Federal specifications related to air particulate filters:

- F-F-310, "Filter, Air Conditioning: Viscous-Impingement and Dry Types, Replaceable" (23 February 1982)
- F-F-1962, "Filter, Air-Extended Media Area Type, for Use in Air Distribution System" (1 March 1978)

- F-F-2790, "Filter, Air-Extended Area, Initial Installation" (27 November 1991)
- F-F-320B, "Filters, Electronic Air Cleaning, Ionizing Plate Type" (updated 15 February 1991).

See Appendix A for excerpts from F-F-1962 and F-F-2790.

Military Specifications

Department of Defense Standard 35-41A(MI) (June 1992, p 3) contains a title indexed listing of military specifications pertaining to particulate and gas-phase filters. The IHS also publishes an indexed listing of military specifications relating to particulate and gas-phase filters (Information Handling Services, 1994, pp 610-611). The following list gives some examples of military specifications related to particulate filters:

- MIL-F-11150A, "Filter, Particulate, 150 CFM, ABC-M9" (27 December 1961)
- MIL-F-50043, "Filter, Particulate, 600 CFM, C18" (updated 23 February 1987)
- MIL-F-50044, "Filter, Particulate, 1200 CFM, C19" (updated 24 February 1987)
- MIL-F-50045, "Filter, Particulate, 2500 CFM, C30" (updated 24 February 1987)
- MIL-F-51068F, "Filter, Particulate, High-Efficiency Fire Resistant" (11 August 1988)
- MIL-F-51165B, "Filter, Particulate, 150 CFM, M9A1" (25 May 1988)
- MIL-F-51366A, "Filters, Particulate: Recirculation (550 CFM and 1200 CFM)" (29 December 1987).

Excerpts from MIL-F-11150A are given in Appendix A.

USACE publishes guide specifications on HVAC air supply and air-distribution systems (Corps of Engineers, 1993, section 15895) that contain information on air filters (excerpts of general requirements and filter types are in Appendix A). The current guide specification cites ASHRAE 52-1976 as a reference instead of ASHRAE 52.1-1992, which supersedes ASHRAE 52. No documentation on HEPA filter leak testing is provided in the Corps Guide Specification. A recommended practice by the Institute of Environmental Sciences was developed recently for the leak testing of HEPA filters used in cleanroom applications. Besides using dioctylphthalate (DOP) as a test aerosol, corn oil, mineral oil, and diethylsebacate are approved as replacement test substances, each with varied particle size distributions (NAFA 1993, p 8.4).

ASHRAE Standard 62-1989

ASHRAE Standard 62-1989 (1990, p 5) states: "When it is necessary to remove particulate contaminants, air filters or dust collectors should be used....Air filters and dust collectors shall be selected for the particle size and loading encountered. Filters shall be tested in accordance with ASHRAE Standard 52-76 or MIL Std 282."

On recirculation criteria, ASHRAE (1990, p 12) specifies that if "cleaned, recirculated air is used to reduce the outdoor air flow rate below the values shown in Table 2 [of ASHRAE Standards Project Committee 62-1989, 1990], the Air Quality Procedure...must be used. The air-cleaning system for the recirculated air may be located in the recirculated air or in the mixed outdoor and recirculated airstream." The Indoor Air Quality Procedure contains a section on air cleaning that emphasizes the effectiveness of controlling airborne contaminants using recirculation with air-cleaning systems (ASHRAE Standards Project Committee 62-1989, 1990, p 15).

SMACNA Guidelines on Particulate Contaminant Removal

SMACNA (Energy Management Committee 1989, p 8.5) states: "In order to remove particulate air contaminants in the respirable size range, particle filters must be of sufficient efficiency and capacity to remove submicron particles with a high degree of reliability. Filters with a minimum ASHRAE 52-1976 efficiency of 90 percent and a minimum depth of six inches (150 mm) (for desired six-month minimum life cycle) are required. The filters must be used in conjunction with gas adsorption filters capable of removing a broad range of gases and vapors commonly found in the outdoor and indoor environment."

Classification of Filters

Filters having an ASHRAE dust spot rating of 10 to 20 percent, or less, are classified as low efficiency filters. Medium efficiency filters (preferably pleated-type) have an ASHRAE dust spot rating of 30 to 60 percent. High efficiency extended surface filters are rated, according to the ASHRAE dust spot method, from 85 to 95 percent (EPA, December 1991, pp 126-127). Table 3 shows various air filter types according to comparable ratings by DOP testing, dust spot testing, and arrestance. Low efficiency filters in HVAC systems are mainly used to protect heating and cooling coils from dirt buildup. The life of higher efficiency filters can be prolonged by using prefilters having various arrestance efficiencies. "Higher efficiency filters," according to Newman (1991, p 69), "have a higher pressure drop and require more fan horsepower."

Table 3. Particulate filter types and selective ratings.

Approximate Ratings			Typical Applications and Limitations	Typical Contaminant Controlled	Typical Air Filter Types
A	B	C			
99.97			Clean rooms Radioactive materials	Toxic dusts Virus	HEPA and ULPA filters*
80	98		Hospital inpatient care Smoking lounges	Bacteria Tobacco smoke Particulate	Microfine fiberglass or synthetic media bag filters
50	90		Hospital laboratories Better office building ventilation	Staining dirt Most bacteria	Box style filters with paper media Industrial electronic air cleaners
35	80		Office building ventilation Better residential heating	All pollen Oil smoke	
	60		Paint booth inlet air Welding fume removal	Finer dusts Most pollen	Same as above mechanical filters Residential electronic air cleaners Deep pleated residential filters
	40	96	Commercial building ventilation	Most mold and spores	Pleated filters 1 in. to 4 in. thick
	25	93	Residential heating equipment	Ragweed pollen	Disposable fiberglass
		80	Window air conditioners	Coarse dust	Polyester panel filters Urethane foam rubber
		65	Minimum filtration	Lint	Self-charging electrostatic Cleanable aluminum mesh
		50			Latex-coated animal hair

Source: Ottney, July 1993, p 32. (©1993 American Society of Heating, Refrigerating and Air-Conditioning Engineers, Inc., Atlanta, GA. Used by permission from ASHRAE Journal, vol 35, no. 7.)
*HEPA = high efficiency particulate air; ULPA = ultra low penetrating air. A = DOP efficiency percentage (Military Standard 282, February 1989); B = dust spot efficiency percentage (ASHRAE Standards Project Committee 52.1P, 1992); C = arrestance percentage (ASHRAE Standards Project Committee 52.1P, 1992).

Standards for Determining and Measuring Particulate Filter Performances

Although filters aid in relieving occupant concerns, according to Hansen (1991, pp 201-202), "Filters also preserve the 'health' of the entire ventilation system by preventing the accumulation of material downstreams in ducts, fans, coils and other ventilation components. It is far more difficult and costly to fix downstream problems and to remove contaminants than to maintain an effective filtration system." Locating filters in the recirculated airstream is necessary when air contaminants are derived from an occupied space. Otherwise, filters can be located in the air supply for outdoor air contaminants. When filters are clogged, the resistance increases and system efficiency is reduced. Considerations in design that affect filter maintenance include filter accessibility (location of the unit, limited space, etc.) and filters that do not cover the opening (Hansen 1991, p 202). In terms of variable-air-volume (VAV) systems, because volumetric flow and filter effectiveness govern the amount of filterable material generated, "the reduced flow in a VAV system reduces contaminant removal capacity" (Hansen 1991, p 203). To compensate for the reduced flow, increasing the filter effectiveness (obtained by manufacturer data) or installing additional filtration and recirculating the ventilation air are possible remedies. Filters should be changed on a regular basis, particularly when the static pressure drop reaches the manufacturer/design level. Before installing a new filter, vacuuming the filter area is recommended (Hansen 1991, p 203).

According to Burge (1987, p 34), "Filters that are designed to collect particles either from outdoor or recirculated air are always contaminated. If dry and undisturbed, such contamination does not change the air spora and presents no health risk. If wet, accumulated dirt can provide an excellent culture medium and fungi can grow through to the downstream side of the filter and enter the building's air. When filters are disturbed (changed), contaminating particles are shaken loose and become airborne."

Mechanical filters frequently are tested based on their performance and filtering capabilities. A complete evaluation of air filters requires data on efficiency, airflow resistance, dust-holding capacity, and the effect of dust loading on efficiency and resistance (Parsons 1992, p 25.2). Four tests relating to particulate filters are being addressed.

ASHRAE Standards

ASHRAE cited two test methods for evaluating filter performance: (1) weight arrestance testing and (2) atmospheric dust spot testing (ASHRAE Standards Project Committee 52.1P, 1992, p 1; EPA, December 1991, p 138).

Weight Arrestance Test. The weight arrestance test generally serves as an evaluation criterion for low efficiency filters “designed to remove the largest and heaviest particles ...” (EPA, December 1991, p 138). A standard synthetic dust is fed into the air cleaner, and the proportion of the trapped dust (by weight) is determined. Low efficiency filters are used primarily in residential furnaces and/or air-conditioning systems. Likewise, they are used as upstream filters for other air cleaning devices (EPA, December 1991, p 138). Arrestance is defined (in percent) by the equation:

$$\text{Arrestance} = 100 * \left[1 - \left(\frac{\text{mass gain of after-filter}}{\text{mass of dust fed}} \right) \right] \quad [\text{Eq 1}]$$

The after-filter (or final filter) is defined by ASHRAE (1992, p 25.2) as the filter used to capture dust passing the test filter during the measurement of arrestance. The final filter can be any of three forms (flat sheet media, pleated, or cartridge), but the portion that is weighed for arrestance is called the “weighable portion” (ASHRAE Standards Project Committee 52.1P, 1992, p 14). Figure 1 is an ASHRAE air filter test duct (with blower located upstream of test filter) that specifies a section where the final filter is placed. Figure 2 is one of the three types of final filters discussed in Standard 52.1 (ASHRAE Standards Project Committee 52.1P, 1992, p 15). The ASHRAE synthetic test dust (as specified in ASHRAE Standard 52.1) is “composed by weight of 72% Standardized Air Cleaner Test Dust, Fine; 23% of powdered carbon; and 5% of cotton linters” (Parsons 1992, p 25.3). Offermann, Loisselle, and Sextro (July 1992, p 55) commented, “ASHRAE weight arrestance data reflect a filter’s ability to remove large non-respirable particles.” According to SMACNA (Energy Management Committee 1989, p 8.4), the weight arrestance method “is used to measure the performance of filters whose main function is to keep HVAC systems from fouling. The arrestance method, however, does not measure the respirable fraction of particles (those between 0.1 and 10 micrometers), which most affect health and comfort.”

Atmospheric Dust Spot Test. The USEPA states (EPA, December 1991, p 138) that the “efficiency” or rating of an air cleaner (particularly medium efficiency air cleaners) is determined using the atmospheric dust spot test. “The removal rate is based on the cleaner’s ability to reduce soiling of a clean paper target, an ability dependent on the cleaner removing very fine particles from the air” (EPA, December 1991, p 138). The atmospheric dust spot test measures the ability of a filter to reduce the soiling of fabrics and building interior surfaces, but it is most useful for high efficiency filters because of its effectiveness in handling fine particles (Parsons 1992, p 25.2).

Note: Units shown are mm (in.).

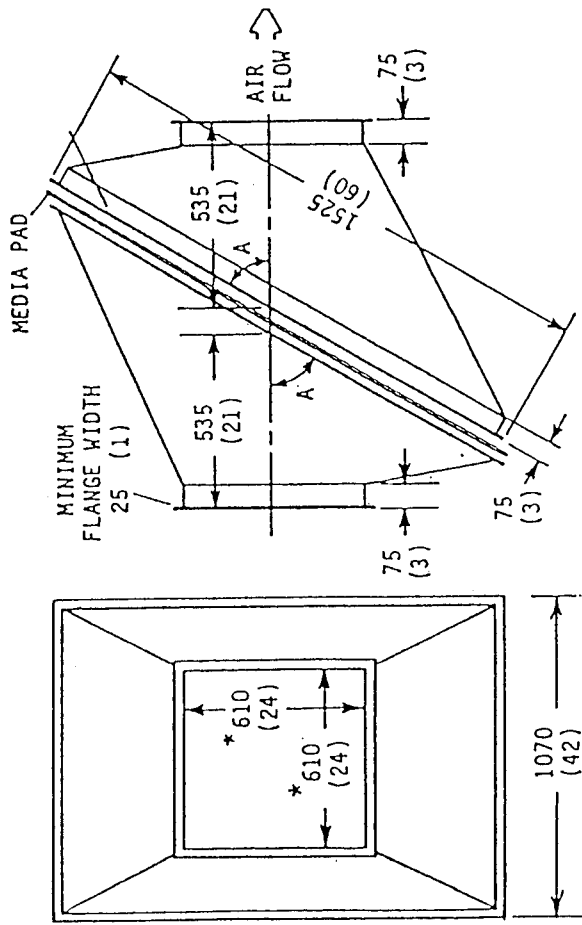

1. MEDIA PAD AND GRID/FLANGE DIMENSIONS ARE MANDATORY MINIMA, EXCEPT FOR THOSE MARKED WITH ASTERISKS (*), WHERE THE TOLERANCES ARE ± 3 ($\pm 1/8$).
2. LONGER AND WIDER PAD LENGTHS ARE PERMISSIBLE. MAXIMUM BACKUP GRID WIRE SPACING IS 51 MM (2 IN.).
3. PAD ORIENTATION MAY BE CHANGED; ANGLE "A" MAY RANGE FROM 9° TO 90°.

Source: ASHRAE Standards Project Committee 52.1P, 1992, p 15. ©1992 American Society of Heating, Refrigerating and Air-Conditioning Engineers, Inc., Atlanta GA. Used by permission from ANSI/ASHRAE Standard 52.1-1992.)

Figure 2. Final filter in disposable cartridge form.

In addition to the weight arrestance and atmospheric dust spot tests, other test methods and performance criteria have been implemented to enhance filter performances.

DOP Test

The DOP test is commonly used in testing dust-removal efficiencies of both HEPA and ULPA filters. DOP "creates a known particle size distribution when atomized" (Parsons, 1991, pp 16.1-16.2). The DOP test was originally used in evaluating M13 particulate filters with rated flow capacities of 12 cfm, based on Military Standard 282, approved since May 28, 1956 (February 1989, p 19). According to this standard, a chemical originally produced by Union Carbide was used in the smoke generator to measure the amount of smoke penetration in the filter (Military Standard 282, February 1989, p 20).

Effective Cleaning Rate and System Efficiency

The effective cleaning rate (ECR) and system efficiency can be used to measure air cleaner performance. According to Offermann, Loiselle, and Sextro (July 1992, p 54), the "difference in particle decay rates observed with and without the air cleaner operating, multiplied by the overall test space volume" is defined as the ECR, and the system efficiency is calculated by dividing the ECR by the "air flow rate through the forced air furnace system"... the "combined effects of both the filter efficiency and air leakage past the installed filter" make up the system efficiency. "Uncertainties because of the measurement of particle concentration do not effect the ECR if we assume that the measurement accuracies ... are independent of time (i.e., no drift) and concentration change (i.e., negligible changes in counting efficiency)" (Offermann, Loiselle, and Sextro, July 1992, p 54). Offermann et al. (1985, p 1763) also comment that the ECR "is particularly useful ... in comparing air cleaning to ventilation as an indoor air quality control technique."

Dust-Holding Capacity Test

The dust-holding capacity is "the integrated amount of dust held by the filter up to the time the dust-loading test was terminated." The test requires that "arrestance be measured at least four times during the dust-loading process and that the test be terminated when two consecutive arrestance values of less than 85%, or one value equal to or less than 75% arrestance of the maximum arrestance have been measured" (Parsons 1992, p 25.3).

Comments on ASHRAE Testing Methods

“The current ASHRAE testing criteria are not ideal, because they do not control for particle size....Particulates less than one micron can represent more than 90% of the total particulate count of common indoor air, and those between 0.1 and 1.0 micron most easily penetrate media filters. (A 90% efficient filter, as measured by the dust spot method, may be less than 60% efficient for particulates in this range.)” (Cutter Information Corporation, August 1991, p 2).

3 Gas-Phase Filtration

Health and Comfort Issues Concerning Gaseous Contaminants

SMACNA reports that several gaseous contaminants normally are found in the indoor environment of modern homes and office buildings, and the source for a majority of those contaminants may be found both indoors and outdoors (Energy Management Committee 1989, p 5.2). Gaseous contaminants, whether man-made or produced by nature, can cause health problems from headaches to death, depending on their concentration and toxicity. The major IAQ gaseous contaminants will be discussed in terms of health and comfort issues.

Carbon Dioxide

Carbon dioxide, according to Hansen (1991, p 99), "is used to define a lower limit of outdoor air needed to ventilate a building." Carbon dioxide is released into the atmosphere when persons exhale. In addition to humans, other sources of carbon dioxide as an indoor pollutant include cigarette smoke and unvented convective heaters (using natural gas as fuel) (Parsons 1991, pp 40.5-40.7). ASHRAE Standard 62-1989 (1990, p 13) establishes 1000 parts per million (ppm) as the basis for indoor ventilation air requirements, although the typical outdoor ambient concentration of carbon dioxide is between 250 and 350 ppm (Hansen 1991, p 99). Exceeding the basis level generally indicates inadequate ventilation. Building occupants can experience headaches, fatigue, and eye and respiratory tract irritation at levels greater than 1000 ppm (Hansen 1991, p 99). According to SMACNA (Energy Management Committee 1989, p 4.2), "Typical outdoor concentrations of carbon dioxide in large cities have been reported at 400 ppm." SMACNA also states (Energy Management Committee 1989, p 5.3), "No major comfort or health effects in buildings have been noted because building levels usually are well below one percent." Carbon dioxide is a colorless, odorless, and tasteless gas, it "has been proposed as an indicator of general air pollution problems and body odors when human occupancy is the major cause of pollution" (Energy Management Committee 1989, p 5.3).

Carbon Monoxide

Carbon monoxide is a colorless, odorless, and tasteless gas that normally is produced from an incomplete combustion of carbon in fuels. Common indoor sources of carbon monoxide include gas ranges, unvented or defective heaters, leaky wood and coal stoves, tobacco smoke, and automobile exhausts (Energy Management Committee 1989, p 5.3). With the formation of carboxyhemoglobin in the bloodstream, the amount of hemoglobin available to carry oxygen to body tissues becomes significantly reduced, and the risk of asphyxiation increases. Dizziness, dull headache, nausea, ringing in the ears, and pounding of the heart are common symptoms. Damage to the central nervous system, the brain, and the circulatory system can result from unconsciousness because of carbon monoxide inhalation. The susceptibility is even greater among young children and victims of asthma, anemia, and heart and hypermetabolic diseases (Hansen 1991, p 259).

Ozone

Ozone has been found to be an irritant of the mucous membranes and the lungs. Much of the ozone produced indoors is found from such sources as photocopiers, electrostatic air cleaners, and other high voltage electrical equipment (Energy Management Committee 1989, p 3.5). In the outdoor air, ozone is a major component of smog. "While ozone in the upper atmosphere is beneficial to life by shielding the earth from harmful ultraviolet radiation from the sun, high concentrations of ozone at ground level are a major health and environmental concern" (EPA, October 1993, p 3-21). Although ozone is not emitted directly in the air, it is formed through complex chemical reactions, which are stimulated by sunlight and temperature. As a result, peak ozone levels occur during warmer seasons (Farr Company 1992, p 26). The USEPA (EPA, October 1993, p 3-21) reports that exposure to ozone at relatively low concentrations has been found to significantly reduce lung function, accompanied by symptoms of chest pain, coughing, sneezing, and pulmonary congestion. In addition, "chronic exposure [to ozone] may cause premature aging of the human lungs" (Shaughnessy and Oatman, 1991, p 318).

Nitrogen and Sulfur Dioxide

Nitrogen dioxide is "a highly toxic lower lung irritant that can interfere with the body's defense against respiratory infections" (Energy Management Committee 1989, p 4.3). Primary indoor sources of nitrogen dioxide include tobacco smoke, automobile exhaust (from or within garages, or taken in by outside air intakes of HVAC systems), and high temperature combustion (such as in gas ranges and unvented space heaters) (Energy Management Committee 1989, p 4.4). In addition to respiratory infections and lung

impairment, other symptoms associated with nitrogen dioxide include eye, nose, and throat irritation. According to studies conducted in both Britain and the United States, "children exposed to elevated levels of NO₂ have twice the incidence of respiratory illness as children not exposed" (Hansen 1991, p 259).

According to the Farr Company (1992, p 26), "Sulfur dioxide is not a common air pollutant for most commercial building applications." Sulfur dioxide generally is found in such indoor sources as kerosene heaters and unvented or poorly vented heaters containing burning sulfur-bearing fuels (Energy Management Committee 1989, p 4.4). Coal fired power plants and domestic fuel emissions are known sources of sulfur dioxide concentrations (Kunz et al. 1990, p 17).

Hydrocarbons

Polycyclic aromatic hydrocarbons (PAHs) are organic gases that are emitted primarily from woodstoves, fireplaces, and unvented kerosene heaters (Energy Management Committee 1989, p 3.7). PAH concentrations, according to Hansen (1991, p 259), usually are low indoors. PAHs are contaminants carried by respirable particles, but the health effects are "very difficult to determine or predict" (Hansen 1991, p 260). Benzo(a)pyrene, a prevalent polycyclic aromatic hydrocarbon in the environment, is a suspected human carcinogen according to the ACGIH (1994, pp iii, 10).

Aliphatic (nonmethane) hydrocarbons are found in indoor sources such as solvents, inks, glues, paints, and photocopier toners (Energy Management Committee 1989, p 4.3). Volatile halogenated hydrocarbons are in a variety of "products such as adhesives, carpeting, fabrics, and clothing spot removers, liquid correctors for the office, insecticides, glues, detergents, etc." (Gilli et al. 1990, p 713).

Volatile Organic Compounds

Volatile organic compounds (VOC) are organic compounds that exist as a gas and have vapor pressures greater than 0.1 millimeter mercury (mm Hg) at 20 °C. VOC emissions are prevalent in sources such as photocopying materials, paints, gasoline, people, refrigerants, personal hygiene and cosmetic products, building materials, molded plastic containers, disinfectants, cleaning products, and environmental tobacco smoke. Respiratory distress, sore throat, eye irritation, nausea, drowsiness, fatigue, headaches, and general malaise (or discomfort) are among the classic symptoms associated with VOC exposure (Hansen 1991, p 284).

Formaldehyde is the most well-known of all VOC. At room temperature, formaldehyde is a colorless gas with an enormously strong odor. Many building products, such as

plywood, paneling, particleboard, fiberboard, urea-formaldehyde foam insulation, adhesives, fiberglass, and wallboard emit formaldehyde. Furniture, shelving, partitions, ceiling tiles, wall coverings, draperies, upholstery, carpet backing, cigarette smoke, natural gas, and kerosene are other sources of formaldehyde. According to Hansen (1991, p 269), "Acute exposure to formaldehyde can result in eye, ear, nose and throat irritation, coughing and wheezing, fatigue, skin rash and severe allergic reactions." Recent research by the USEPA has shown that "formaldehyde may cause a rare form of throat cancer in long-term occupants of mobile homes" (Hansen 1991, p 270).

"The Federal Consensus Panel on Formaldehyde found sufficient evidence to conclude that formaldehyde poses a carcinogenic risk to humans" (Energy Management Committee 1989, p 3.7). However, "the International Agency for Research on Cancer (IARC) concludes that the evidence in humans is inadequate to judge the human carcinogenicity" (Energy Management Committee 1989, p 3.7). In addition to formaldehyde, other common VOC include benzene, toluene, acetone, ethylbenzene, butanol, and propanol (Plett, Vaculik, and Shaw, 1992, p 25).

Radon

Radon is an odorless, colorless gas formed from the decay of radium (Hansen 1991, p 275). The radioactive elements of radon, known as radon daughters, are charged particles which, in turn, absorb particles in the air. Although radon has a radiological half-life of 3.8 days, the longest half-life for radon daughters is about 30 minutes. As a result of this rapid decay, high radiation energy levels are emitted to a relatively small amount of tissue, thereby creating serious injury to the tissues. "When absorbed into the lung cavity," according to Hansen, "radon decay products may increase the incidence of lung cancer" (1991, p 277). Although soil is the primary source of radon, it normally flows through cracks, voids, or other openings in a typical building foundation.

Congress authorized the USEPA to undergo research in radon and IAQ, which is the main focus of the Superfund Bill (P.L. 99-499) (Hansen 1991, pp 2-3). In addition, in 1988 Congress established the Indoor Radon Abatement Act "with the national goal that indoor air be as free from radon as the ambient air outside of buildings" (Guimond, Malm, and Rowson, 1990, p 290). Radon, the USEPA states, is second only to smoking as a cause of lung cancer in America (EPA, December 1991, p 151). Annually an estimated 20,000 lung cancer deaths in the United States are attributed to radon exposures (Matyas 1990, p 83).

Radon problems exist when the following elements are present: (1) a radon source, (2) a pathway that allows radon to enter the building, and (3) a driving force that causes the radon to flow through the pathway and into the building (EPA, December 1991, p 152).

Regulations and Codes on Gaseous Contaminant Concentrations

Gaseous contaminants must be regulated under acceptable concentration limits. Current Federal, military, and state regulations and codes for gaseous contaminant concentrations will be discussed.

Federal Regulations and Codes

National Primary and Secondary Ambient Air Quality Standards. The National Primary and Secondary Ambient Air Quality Standards for sulfur dioxide, carbon monoxide, ozone, and nitrogen dioxide are given in Table 4.

American Conference of Governmental Industrial Hygienists Standards. For various gaseous substances based on 8-hour, TWA, and short-term exposure limits (STELs), the reader is advised that annual updates are published by the ACGIH (see p 12).

OSHA Standards. OSHA standards for gaseous substances based on 8-hour, TWA, and STEL are listed in Table 5.

ASHRAE Standards. Indoor, outdoor, and industrial workplace ASHRAE standards for gaseous contaminants are given in Table 6.

Table 4. National Primary and Secondary Ambient Air Quality Standards—gaseous contaminants.

Pollutant	Primary Standard	Secondary Standard
Sulfur dioxide	80 $\mu\text{g}/\text{m}^3$ (0.03 ppm), annual arithmetic mean 365 $\mu\text{g}/\text{m}^3$ (0.14 ppm), maximum 24 hours	1300 $\mu\text{g}/\text{m}^3$ (0.5 ppm), maximum 3 hours
Carbon monoxide	10 mg/m^3 (9 ppm), 8 hours average 40 mg/m^3 (35 ppm), 1 hour average	
Ozone	235 $\mu\text{g}/\text{m}^3$ (0.12 ppm), maximum hourly average	235 $\mu\text{g}/\text{m}^3$ (0.12 ppm), maximum hourly average
Nitrogen dioxide	100 $\mu\text{g}/\text{m}^3$ (0.053 ppm), annual arithmetic mean	100 $\mu\text{g}/\text{m}^3$ (0.053 ppm), annual arithmetic mean

Source: 40 CFR 50.4, 5, 8, 9, 11.

Table 5. OSHA standard values—gaseous contaminants.

Substance	Adopted Values*			
	TWA		STEL	
	ppm	mg/m ³	ppm	mg/m ³
Acetone	750	1,800	1,000	2,400
Ammonia			35	27
Benzene	10			
Butane	800	1,900		
Carbon dioxide	10,000	18,000	30,000	54,000
Carbon monoxide	35	40		
Chlorine	0.5	1.5	1	3
Chloroform (Trichloromethane)	2	9.78		
DDT (Dichlorodiphenyltrichloroethane)		1		
Ethyl benzene	100	435	125	545
Fluorine	0.1	0.2		
Formaldehyde	0.75		2	
Gasoline	300	900	500	1,500
Methyl acetate	200	610	250	760
Methyl acetylene-propadiene mixture (MAPP)	1,000	1,800	1,250	2,250
Naphthalene	10	50	15	75
Nitrogen dioxide			1	1.8
Ozone	0.1	0.2	0.3	0.6
Pentane	600	1,800	750	2,250
Sulfur dioxide	2	5	5	13
Toluene	100	375	150	560
Trichloroethylene	50	270	200	1,080
Vinyl acetate	10	30	20	60
Vinyl toluene	100	480		

Source: 29 CFR 1910.1000, pp 8-17.
*OSHA = Occupational Safety and Health Administration, TWA = time-weighted average, STEL = short-term exposure limit.

Table 6. ASHRAE standards—gaseous contaminants.

Pollutant	Indoor Standards	Outdoor Standards	Industrial Workplace Standards
Carbon monoxide		National Ambient Air Quality Standard: 10 mg/m ³ (9 ppm) 8 hour average 40 mg/m ³ (35 ppm) 1 hour average.	OSHA: 55 mg/m ³ (50 ppm) 8 hour TWA
Formaldehyde	0.4 ppm target ambient level, HUD standard for manufactured homes, achieved through product emissions standards of 0.2 and 0.3 ppm	No Federal standard	OSHA: 1 ppm, 8 hour TWA-PEL 2 ppm, 15 minute STEL
Nitrogen dioxide		National Ambient Air Quality Primary and Secondary Standards: 100 µg/m ³ (0.053 ppm) annual arithmetic mean	OSHA: 9 mg/m ³ (5 ppm) (ceiling)
Ozone	FDA prohibits devices (e.g., germicides, deodorizers) that result in more than 0.05 ppm in occupied enclosed spaces such as homes, offices, or hospitals, or that result in any releases in places occupied by the ill or infirm	National Ambient Air Quality Primary and Secondary Standards: 235 µg/m ³ (0.12 ppm), maximum hourly average	OSHA: 0.2 mg/m ³ (0.1 ppm) 8 hour TWA
Radon	USEPA: 4 pCi/L, annual average exposure	National Emissions Standard for radon-222 emissions from underground uranium mines - Requires bulkhead construction. National Emissions Standard for Radionuclide Emissions (excluding radon-220, 222) from DOE facilities, other Federal facilities, and NRC licensed facilities: 25 mrem per year, whole body 75 mrem per week, critical organ	Mine Safety and Health Administration: 1.0 WL radon progeny, maximum 4 WLM radon progeny calendar year
Sulfur dioxide		National Ambient Air Quality Standards: Primary: 80 µg/m ³ (0.03 ppm) annual arithmetic mean Secondary: 1300 µg/m ³ (0.5 ppm) 3 hour	OSHA: 13 mg/m ³ (5 ppm) 8 hour TWA

Source: ASHRAE Standards Project Committee 62-1989, 1990, pp 18-20. (©1989 American Society of Heating, Refrigerating and Air-Conditioning Engineers, Inc., Atlanta, GA. Used by permission from ANSI/ASHRAE 62-1989.)
ASHRAE = American Society of Heating, Refrigerating and Air-Conditioning Engineers, HUD = Housing and Urban Development, FDA = Food and Drug Administration, USEPA = U.S. Environmental Protection Agency, DOE = Department of Energy, NRC = National Research Council, OSHA = Occupational Safety and Health Administration, TWA = time-weighted average, PEL = permissible exposure limit, STEL = short-term exposure limit, WL = working level, WLM = working level month.

Military Regulations and Codes

Army Regulations and Codes. Army Regulation 200-1 applies to regulations covered by the CAA (1990, Chapter 4, 4-2 (b)). The U.S. Army refers to sulfur dioxide, carbon monoxide, ozone, and nitrogen dioxide as four of the six "criteria" air pollutants cited by the NAAQS (Army Regulation 200-1, 1990, Chapter 4). The Army Radon Reduction Program (Army Regulation 200-1, 1990, Chapter 11) seeks to "modify all Army-owned structures having radon levels greater than 4 pCi/l (picocuries per liter) so that the levels are reduced to 4 pCi/l or less."

Corps of Engineers Regulations and Codes. Engineer Manual 385-1-1 (1992, p 57) prohibits "exposure to any chemical or physical agent ... in excess of the acceptable limits specified in the American Conference of Governmental Industrial Hygienists."

State of Illinois Regulations and Codes

The Illinois Administrative Code (Secretary of State, 1992, p 299) gives the following state levels for certain gaseous contaminants (see Table 7).

Gas-Phase Filter Design Guidance

Gas-phase filtration involves the collection of gases and vapors by either absorption (in which one substance enters into the inner structure of another) or adsorption (the cohesiveness between a thin film of liquid or gases and the surface of a solid substance) using certain types of media. A basic guide for the design of gas-phase filtration is Military Handbook 144 (1978, p ii), which focuses on the goal of attaining "highly efficient removal of toxic chemical agents in the form of minute particulate, aerosol, and gaseous matter." In particular, this handbook documents specifications for adsorber cells (mostly containing activated carbon). The word adsorbent is defined as: "The adsorbent is the material in the adsorber cells which removes gases or vapors from the airstream to prevent their escape into the atmosphere. Agent capture is accomplished by physically retaining the gaseous molecules or, if the adsorbent is

Table 7. Gaseous concentration levels in Illinois.

Pollutant	Annual	24-hour	8-hour	3-hour
Sulfur dioxide	1 $\mu\text{g}/\text{m}^3$	5 $\mu\text{g}/\text{m}^3$		25 $\mu\text{g}/\text{m}^3$
Nitrous oxide	1 $\mu\text{g}/\text{m}^3$			
Carbon monoxide			0.5 mg/m^3	2 mg/m^3
Source: Secretary of State 1992, pp 298-299.				

impregnated, by chemical reaction, depending upon the type of chemical agent involved" (Military Handbook 144, 1978, p 4-88).

Chemical, biological, and radiological (CBR) filters, as defined by the Department of the Army, contain "an activated carbon unit for the adsorption, retention, and neutralization of chemical agents" (Technical Manual 5-855-4, 1986, p 2-13). However, the "construction of the filters does not provide for the required radiation shielding" (Technical Manual 5-855-4, 1986, p 2-14). In addition, "The portion of outside air to be filtered at all times through CBR filters depends on the requirements of the occupied areas that must be protected within the facility" (Technical Manual 5-855-4, 1986, p 4-3).

Current AHU Filtering Technologies for Gas-Phase Filtration

Activated-Charcoal Filters

Activated-charcoal filters tend to absorb materials with high molecular weights and let materials with lower molecular weights pass through (Energy Management Committee 1989, p 8.4). According to Liu, Raber, and Yu (May 1991, p 44), "For removal of indoor VOCs, use carbon designed for VOC control in the parts per billion (ppb) concentration range. Virgin coconut shell carbon with 60 percent carbon tetrachloride activity is the recommended choice for HVAC applications." According to Edge (1987, p 256), "activated carbon filters are used extensively to absorb many gaseous contaminants from sources such as the galley and water closets."

Enhancing the particle collection efficiency of an activated carbon fiber (ACF) filter by chemical treatment and converting gaseous components to particles by a chemical reaction to collect the fibers more effectively were two considerations of the research conducted by Otani et al. (1991, p S793) to study simultaneous removal of gaseous and particulate matter. By means of chemical treatment applied to the ACF filter, the surface polarity of activated carbon changes, resulting in a dramatic increase in the penetration of charged particles because of Coulombic forces between the particles and ACF. In addition, the collection efficiency of the filter particle is enhanced.

Otani et al. (1991, p S794) state that "the adsorption capacity for gaseous room air pollutants is not high enough for practical use," despite the capability of ACF filters to adsorb organic vapors. ACF filters were impregnated with a series of chemicals "which might react with gaseous pollutants or serve as a catalyst" (Otani et al. 1991, p S794). Using acetaldehyde as a gaseous component and a selection of impregnated chemicals (phosphoric acid, potassium iodide, sulfonic acid, and aniline), aniline was chosen as the most effective impregnant.

The conversion of gaseous components to particles can be accomplished through a chemical reaction so the converted particles can be removed by glass fiber filters. The procedure involves the use of gas from cigarette smoke in reaction with a corona discharge, which generates ozone. Studies involving the effects of corona discharge on organic vapors were applied to the use of acetaldehyde and cyclopentene. Although acetaldehyde does not react directly with ozone, it decomposes by the corona discharge without generation. However, cyclopentene reacts directly with ozone to generate a large number of particles (Otani et al. 1991, pp S795-S796).

Fabric or Cartridge Filters

According to ASHRAE (Parsons 1992, p 26.1), "High-efficiency fabric or cartridge filters are typically used in general ventilation systems to reduce particle concentrations to levels acceptable for recirculated air." Cartridges manufactured from pleated paper also are considered fabric filters because they operate in the same manner as high efficiency fabrics. The cleaning of cartridge filters with pleated paper media is accomplished by using a reverse pulse of compressed air (Parsons 1992, p 26.12). The removal of aerosol particles from gas flows has been successful in fibrous filters. Studies by Stenhouse and Trottier (1991, p S778) conclude, "regardless of the capture mechanisms involved in the filtration process," an increase in both pressure drop and collection efficiency are experienced by the filter as a result of the capture of fine particles (between 0.01 and 0.6 μm in diameter) accumulated on the fibers.

The most common types of fabric filters are known in the industry as baghouses, in which gases containing particles are forced through fabric filter bags. Baghouses are composed primarily of a series of cylindrical cloth fabric (or felt) tube filters, each 6 to 12 in. in diameter and 10 to 30 ft long. The choice of fabric depends on: (1) the gas temperature, (2) the physical and chemical characteristics of the dust, (3) the ability of the fabric to tolerate the corrosive and erosive effects of the gas, (4) the mechanical strength of the fabric, (5) the moisture content of the gas, and (6) the cost. Baghouse filters are not effective when gas temperatures fall below the dewpoint. For a baghouse, the pressure drop ranges from 2 to 6 in. of water for woven fibers and from 6 to 10 in. of water for felts. The removal efficiency for baghouses normally is greater than 99 percent for particles larger than 0.1 μm . Unfortunately, baghouses do not handle moisture-laden gases well because moisture collection on the filter will cause an increase in the pressure drop across the filter (Brockmann, Adkins, and Gelbard, 1991, pp 74-82).

Dry Processed Carbon Composite Adsorbers

Dry processed carbon composite adsorbers were "designed to achieve efficient removal of contaminants at low concentrations in air, by using sorbent particles of high surface area-to-mass ratio" (Kelly and Kinkead, July 1993, p 23). These contain chemical reagents that aid in the removal of such gases as sulfur dioxide, nitrogen dioxide, ozone, and formaldehyde.

Filters Using Porous Pellets

Chemisorption media (including porous, spherical pellets made of activated alumina and treated with a chemical impregnation system--typically potassium permanganate) use the processes of absorption, adsorption, and chemical oxidation. The oxidation takes place within the impregnation system and converts the gaseous contaminants into solid particles. "Chemisorption media are particularly effective filtering agents, since they are reactive against a very broad spectrum of gases and vapors" (Kennedy and DiStefano, November 1991, p 77).

Lithium Carbonate Filters

Edge (1987, p 256) reports that, by using a lithium carbonate filter in the exhaust duct of a submarine from the carbon monoxide-hydrogen burner, harmful byproducts produced by hydrocarbon combustion can be successfully removed. "Filters play a vital role in maintaining air quality aboard a submarine" (Edge 1987, p 256).

Three-Level Air Filtration System

In spite of major concerns of introducing harmful contaminants (such as fiber glass wool fibers and microscopic carbon particles) into the air, "a three-level filtration system [provided by International Air Filter] with nonshedding microsynthetic filters both upstream and downstream was recommended for use at the new [United Airlines] terminal" at O'Hare International Airport in Chicago, IL (News in Review, October 1988, p 11). Existing filtration systems at the older terminals "combined medium-efficiency fiber glass wool filters for particulate control with activated carbon filters for control of jet fumes and other odors" (News in Review, October 1988, p 11). Testing of the new filtration system indicated "measurable amounts of aluminum, silica, chlorine, potassium, calcium, iron, sulphur, and various hydrocarbons" were captured (News in Review, October 1988, p 11). Although the high-efficiency downstream filters capture 90 percent of carbon particles 0.1 μm and smaller, the microsynthetic filters have lower air resistance than fiber glass units and increase the energy-efficiency of the terminal's HVAC system (News in Review, October 1988, p 11).

Gas-Phase Filter Requirements and Specifications

Information Handling Services, Inc., which publishes current military and Federal specifications available on microfilm, does not provide any Federal specifications on gas-phase filters. However, there are military specifications dealing with gas-phase filtration.

Military Specifications

Department of Defense 35-41A(MI) (June 1992, p 3) contains an indexed listing of military specifications relating to particulate and gas-phase filters. A listing of specifications pertaining to gas-phase filters follows (Information Handling Services, 1994, pp 610-611):

- MIL-F-0011137E(EA), "Filter, Gas, 150 CFM, M10" (13 December 1989)
- MIL-F-0014512J, "Filter, Gas, 12 CFM, M12A1" (28 March 1991)
- MIL-F-51222C, "Filter, Gas, 150 CFM, M23" (10 July 1991)
- MIL-F-15919D, "Filters, Air, Activated Carbon, Submarine Sanitary Tank Vent and Water Closet" (8 November 1971)
- MIL-F-51369B, "Filters, Gas: Recirculation (550 CFM and 1200 CFM)" (updated 3 November 1989).

An excerpt of specifications from MIL-F-0011137E(EA) (December 1978) are given in Appendix B.

ASHRAE Standards

According to ASHRAE (1990, p 6), "When compliance with this section does not provide adequate control of gaseous contaminants, methods based on sorption with or without oxidation or other scientifically proven technology shall be used....The selection of gaseous contaminant control equipment for recirculation systems must consider the concentration, toxicity, annoyance, and odor properties of the contaminants present and the levels to which these must be reduced to be effective in maintaining air quality."

SMACNA Guidelines on Gaseous Contaminant Removal

SMACNA states (Energy Management Committee 1989, pp 8.5-8.6), "The adsorption filters should contain gas adsorbers and/or oxidizers such as activated charcoal and alumina impregnated with potassium permanganate, depending on the gases present or anticipated in the airstream. They must be of sufficient capacity to remain active for a full service cycle (recommended as six months at 24 hours per day, seven days per

week) and designed so velocity through the collection bed provides a residence time approximating 0.06 seconds, yield high efficiency collection of many commonly found gases.... filtration systems should contain their own fan system....Air should be circulated through these systems at rates of between six and 10 times per hour with distribution of cleaned air being ducted to discharge diffusers. The air can then circulate in a sweeping pattern across a space to return air intakes on the opposite side of an occupied zone, such intakes either being ducted to the filtration system or open to a conditioned return air plenum.”

Classification of Filters

Gas-phase filters operate by adsorption, absorption, and/or chemical reaction to remove gaseous contaminants from an air stream (Kennedy and DiStefano, November 1991, p 77). Table 8 lists common gases and vapors and their corresponding removal media used in gas-phase filters. Table 9 lists a summary of gas-phase filter types and their characteristics.

Table 8. Gases and respective removal media.

Gas or Vapor	Removal Media
Acid gases	Activated carbon
Carbon dioxide	Molecular sieves; lithium oxides; sodium oxides; potassium oxides
Carbon monoxide	Activated alumina impregnated with platinum or rhodium oxides
Formaldehyde	Activated alumina impregnated with compound consisting of copper chloride and palladium chloride
Hydrogen sulfide	Activated alumina impregnated with potassium permanganate
Mercury vapor	Activated carbon impregnated with iodide, silver, sulfur, or potassium iodide
Nitrogen dioxide	Activated carbon impregnated with sodium bicarbonate (baking soda)
Organic vapors	Activated carbon; porous polymers
Ozone	Activated carbon
Polar organic compounds (alcohols, phenols, aliphatic and aromatic amines, etc.)	Activated alumina; activated bauxite; silica gel
Radioactive iodine	Activated carbon impregnated with iodide or potassium trioxide
Sulfur dioxide	Activated alumina impregnated with potassium permanganate
Water vapor	Silica gel

Source: Parsons, 1991, p 40.11. (©1991 American Society of Heating, Refrigerating and Air-Conditioning Engineers, Inc., Atlanta, GA. Used by permission from 1991 ASHRAE Handbook: HVAC Applications.)

Table 9. Gas-phase types and characteristics.

Filter Type	Media Type	Face Velocity	Pressure Drop	Concentration	Removal Efficiency or Activity Rating
Activated carbon	Activated carbon	500 fpm	0.35 in. wg	Minimum 45 pounds of carbon per 1000 cfm of air flow	Minimum activity rating of 50% (by carbon tetrachloride test)
Gas removal	Caustic impregnated carbon or activated alumina; shall be UL* listed as Class 1 or 2 material.	250 fpm	0.15 in. wg	Inlet of 100 ppb	80% (Minimum sulfur dioxide removal)

Source: General Services Administration, October 1989, pp 8-10.
 *UL = Underwriters' Laboratories.

Standards for Determining and Measuring Gaseous Filter Performances

ASHRAE Guidelines on Gaseous Contaminant Removal Devices

ASHRAE Standard 62-1989 (1990, p 6) states, "The performance of gaseous contaminant removal devices often depends strongly on the physical and chemical properties of the individual contaminants present, on the temperature and humidity of the air, on the air velocity through the device, and its loading capacity." Although gas-phase performance standards currently are not available, ASHRAE is sponsoring research projects "aimed at developing a standard that will test and rate the performance of different types of gas phase air purification equipment at low concentrations" (Kelly and Kinhead, July 1993, p 14). ASHRAE is developing test methods to measure removal efficiency using simple gas mixtures, and research currently is being pursued to develop test methods for measuring the useful life of filtration beds before breakthrough (Cutter Information Corporation, August 1991, p 4).

USEPA Guidelines on Gaseous Contaminant Removal Devices

In 1991 the USEPA stated (EPA, December 1991, p 85), "There are no standards for rating the performance of gaseous air cleaners, making the design and evaluation of such systems problematic."

4 Developing AHU Filtering Technologies

The USEPA states (EPA, December 1991, p 84) that “to provide better indoor air quality for occupants,...” proper selection and design of air-cleaning equipment is necessary “for the particular pollutants of interest.”

The Sheet Metal and Air Conditioning Contractors National Association (SMACNA) discusses the importance of filtration and indoor air quality, “In order for filtration to achieve its desired goal of mass contaminant reduction resulting in high indoor air quality, the filtration system must be designed, located and applied properly. A proper system of filters must be employed, comprised of high efficiency particle filters and gas adsorption filters, located in order to ensure that contaminants are circulated through them at high rates, and applied in such as manner that air distribution and mixing is enhanced” (Energy Management Committee 1989, p 8.5). Currently, HVAC systems use media filters and electrostatic air cleaners as commonly operated mechanical filters (Hansen 1991, p 202).

It should be emphasized that these technologies are presented to provide the reader information on filtration systems. Three of the technologies (drum filtration, baghouses, and stacked-disc filtration) typically are designed for the removal of solid and liquid substances from industrial processes and are included here for completeness.

Drum Filtration

Harrington (March 1993, pp 85-88) cites seven reasons why drum filtration, compared to baghouse filters, is “often the best choice in a fibrous particle generating industry”:

- A high pick-up velocity of the air will prevent accumulation of dust in ducts and filter housings before the dust becomes caught by the medium, thereby withstanding higher vacuum pressure.
- More open media can be utilized, “since fibrous particles tend to get trapped lengthwise across filter openings.”
- Less of a pressure drop is required, provided “the filter medium used by a drum filter is much more open.”

- With higher air velocities, more particles can get forced through the filter medium instead of being captured. Furthermore, "larger volumes of air can be filtered quickly and effectively through relatively small filter areas."
- There is a trade-off between particle release and medium cleaning cycles. Although cleaning requires as little force possible, "fibrous particles generally have very good release characteristics due to their smooth texture, dryness, low pickup velocity, and low density," meaning that "drum filter cleaning methods are less expensive because they are simpler and quicker, use less energy, and are easier on filter media than baghouse cleaning methods."
- Because drum filters are smaller than baghouses, they can be more easily installed inside a plant, thereby eliminating the need for expensive waterproof housings. Furthermore, energy cost savings in air-conditioning and heating systems will be enormously beneficial.
- The drum filter medium can easily be replaced in a short amount of time, plus the "maintenance time is less than a tenth of that needed for a baghouse."

Composite Medium for HEPA Filters

A composite sintered filter medium made from a mixture of stainless-steel and quartz fibers was developed to have a desired resistance to high temperatures, as compared to standard HEPA filter media, which "cannot withstand temperatures above 250°C due to the burning of the adhesive that bonds the glass fibers together" (Bergman et al. 1990, p 12). Quartz microfibers, with an average diameter of 0.5 μm , provide high efficiency, whereas stainless-steel fibers with an average diameter of 2 μm , provide bonding for the quartz fibers, thereby giving the composite high strength. The filter efficiency and pressure drop of the composite medium were similar to standard HEPA media (Bergman et al. 1990, p 12).

Electric HEPA Filters

"The performance of a conventional air filter can be significantly improved by converting it to an electrostatic filter" (Bergman 1990, p 17). And electrification of an HEPA filter is relatively easy, "since many HEPA filters already use aluminum separators to maintain the spacing between the pleated filter medium." Conversion from a standard HEPA filter to an electric HEPA filter is accomplished by first exposing every other separator on one side of the composite filter and then connecting each exposed separator electrically by a single electrode bus. To complete the conversion, a ground electrode bus is applied on one side of the filter, and high voltage is applied on the other side.

Based on laboratory experiments conducted by Bergman (1990, pp 17-20), applying 1.25 kilovolts (kV) to the HEPA filter results in a remarkably increased efficiency (greater than 99.999 percent). However, pinholes resulting from electric sparking can occur in the filter medium whenever the applied voltage exceeds 1.25 kV. "Applying high voltage to one electrode separator while grounding the adjacent separator will obviously produce sparks at the points of closest contact" (Bergman 1990, p 19).

Metal-Fiber Deep Bed Filters

Metal-fiber deep bed filters consist of "a prefilter section that removes large particles and water droplets, an impingement-type droplet separator to prevent entrained droplets from the prefilter being carried further, and a fine filter to remove the particulate" (Brockman, Adkins, and Gelbard, 1991, pp 64-67). The fine filter contains stainless steel fibers that are 2 μm in diameter, and the prefilter contains four levels of fiber diameters of 30, 22, 12, and 8 μm . With a face area of 21.5 square feet (sq ft), the flow rate is 1180 cfm at a face velocity of 55 fpm, with a pressure drop of 20 in. of water (clean filter) at the same face velocity. The weight of the filter media is 51 lb.

Glass-Fiber Deep Bed Filters

Glass-fiber deep bed filters contain "beds of compacted fiberglass wool in steel trays held in place by screens" (Brockman, Adkins, and Gelbard, 1991, p 69). The face velocity of the flow through a glass-fiber deep bed filter is 25 to 50 fpm. The fiber diameters, the bed depth, the flow rate, and the particle loading are factors determined by the amount of pressure drop generated by the filter. For a unit rated at 32,000 cfm with an operating face velocity of 50 fpm, the required filter flow area would be 640 sq ft. Water and moisture may raise the value of the filter flow resistance, if they are collected in regions of small fiber diameters (Brockman, Adkins, and Gelbard, 1991, pp 69-73).

Stacked-Disc Filters

The use of stacked-disc filters in industry has been prevalent in the filtration of liquid polymers and suspensions. Stacked-disc filters consist of a stationary layer of concentric disks separated by filter media, with the entire unit contained exclusively in a pressure-resistant casing. Meerman and Brouwers (December 1993, p 3983) performed a study analyzing the clean pressure drop of non-Newtonian fluids across stacked-disc filters (non-Newtonian fluids exhibit the property that viscosity is

dependent on the rate of shear). The liquid radially enters the supply gaps between two inner rings, and the liquid spreads equally over the various gaps. Through experimental and theoretical results, "the flow resistance of the filter medium is much larger than the resistance of the gaps" (Meerman and Brouwers, December 1993, p 3986).

Integrated Air Purifier

Masuda et al. (July/August 1993, p 774) reported the development of a new type of air purifier for a simultaneous control of aerosol, microbial, and odor in living environments. "Use is made of low-concentration ozone in combination with an electrified minipleats filter for killing bacteria, fungi, viruses, and other microbials as well as small insects with a long-term exposure in the filter media where they are collected." An ozone-decomposing catalyzer, made of titania-silica ceramic, is capable of decomposing odors using ozone molecules, which in turn are decomposed to provide oxygen radicals. A semiconductor ozone sensor signals an alarm indicating when the outlet ozone concentration exceeds a safety threshold. Using a low ozone concentration results in deodorization and sterilization capabilities of the air purifier.

5 Research and Other Developments in Filtration

Fractional Efficiency Test Method

A new fractional efficiency laboratory test method for air cleaners has been implemented by the Research Triangle Institute in conjunction with ASHRAE to provide "a reliable and accurate means of measuring air cleaner fractional efficiencies over the particle diameter size range of 0.3 to 10 μm " (Hanley, Smith, and Ensor, April 1993, pp 1-2). Hanley, Smith, and Ensor (April 1993, pp 1-2) commented, "because the new method provides a more detailed assessment of an air cleaner's performance than the current efficiency and weight arrestance tests of ASHRAE 52.1-1992, use of the new method may lead to the development of improved air cleaners."

Testing showed that the new method used the following items: "an artificially generated, stable polydisperse test aerosol; sequential upstream-downstream sampling performed with a single white-light or laser-based light scattering aerosol optical particle counter; a test duct having filtered inlet air and operated at positive; and, for dust loading, the ASHRAE 52-76 arrestance dust without the carbon black component, thereby rendering it nonconductive and compatible with dust-loading of electronic air cleaners" (Hanley, Smith, and Ensor, April 1993, pp 1-2).

Indoor Air Pollution Abatement Process

A recent development proposed by Rodberg et al. (1991, p 313) suggested that a new indoor air pollution abatement process "can effectively and economically reduce the levels of pollutants from a multi-source, multi-pollutant airstream....This new technology can efficiently and permanently reduce the concentration of ozone and a wide range of VOCs" and this process "shows potential for reducing microbiological aerosol levels." This process is "designed to function at linear velocities of about 500 feet per minute, less than one inch of water column pressure drop, and will operate under a slight vacuum" (Rodberg et al. 1991, p 313).

New Filter Selection Methodology

According to Fencel (September 1993, p 15), the Farr Company, noted for graphic charts on filter efficiencies versus ventilation rates, suggested a new filter selection technique that "not only supports and builds on ASHRAE Standard 62-89 but facilitates its use by providing an engineering basis for selecting air filtration equipment." This technique is formulated on the basis of "filtration to achieve air quality equivalent to 100% outdoor air, a concept first set forth by ASHRAE Standard 62-1981" (Fencel, September 1993, p 15). Only two steps are required:

- Step 1: selecting the amount of outdoor air required per person to dilute indoor contaminants; and
- Step 2: deciding what portion of the outdoor air from step 1 is to be substituted with filtered, recirculated air.

A rating system is then used to simplify the filter selection process further. Particulate filters are rated according to their efficiency on 0.3 μm particles, carbon adsorbers are rated on their performance with toluene, a representative compound of targeted VOC. However, Fencel (September 1993, p 15) suggests that gas and vapor adsorbers must be used with particulate filters.

Universal Air Filter Classification System

Research recently was completed by ASHRAE to propose a new particle size efficiency standard, with the argument that adopting a European-type filter class system "lends itself to unambiguous product labeling and it can be used no matter which test standard is used" (Ottney, September 1993, p 56). The European Committee of Ventilating Equipment Manufacturers, known as a trade association of HVAC manufacturers, uses EU to designate air filter classes. Currently, according to Ottney (September 1993, p 56), "Arrestance is the method applied to the least efficient category of air filters: dust spot is used to compare the medium and high efficiency products; and DOP is used for ultrahigh efficiency air filters." A universal filter classification has been devised relating nine European filter classes to average arrestance and dust spot efficiency. The European system, according to the German Standards Institute (DIN) Standard 24185, uses the following basis efficiencies: 95 percent arrestance for class EU4; 90 percent dust spot for class EU8; and 95 percent DOP for class EU9. According to Ottney (September 1993, p 57), "Europeans are working on a plan to be introduced in 1994 that will expand the classifications to include HEPA and ULPA filters in classes 10 through 17." Table 10 lists how each filter class relates to arrestance and average dust spot efficiency.

Table 10. Universal air filter classes.

Filter Class	Average Arrestance, A_a (percent)	Average Efficiency, E_a (percent)
EU 1	$A_a < 65$	
EU 2	$65 \leq A_a < 80$	
EU 3	$80 \leq A_a < 90$	
EU 4	$90 \leq A_a$	
EU 5		$40 \leq E_a < 60$
EU 6		$60 \leq E_a < 80$
EU 7		$80 \leq E_a < 90$
EU 8		$90 \leq E_a < 95$
EU 9		$95 \leq E_a$

Source: Ottney, September 1993, p 57.

Replacement Materials for DOP Testing

Because of recent reports on potential health hazards associated with humans working with DOP test aerosols, in April 1986 the U.S. Army Surgeon General placed severe restrictions on conducting 100 percent quality assurance testing of filters and other equipment. Two years later, the U.S. Army underwent a detailed study to find acceptable and alternative substitute materials for DOP "that could meet all standard military test specifications while itself being a noncarcinogen and, ideally, having other attributes including acceptable acute inhalation toxicity, low cost, ready availability, and the ability to replace DOP directly in machines at test installations without retrofit or other modification of these machines" (Carlton, Guelta, and Gerber, 1991, p 234). The recommended replacement materials for DOP were synthetic hydrocarbons (poly-alpha olefins [PAOs]), isostearic acid, and oleic acid. Although PAOs now are the U.S. Army's primary replacement for DOP in hot smoke machines, isostearic acid serves as a viable replacement for DOP in hot and cold smoke machines. However, the unsaturated molecular structure of oleic acid exhibits higher susceptibility to chemical breakdown and byproduct formation than the other two replacement materials (Carlton, Guelta, and Gerber, 1991, pp 233-246).

Current ASHRAE Research Projects

The research projects in Appendix C are sponsored by ASHRAE and are directly related to filtration and IAQ research.

6 Conclusion

This report reviewed AHU filtering technologies for both particulate and gas-phase contaminants. A literature search revealed many gaps in knowledge in this field; in particular, there is a lack of comprehensive standards and guidelines for HVAC and AHU systems. Increased particulate removal may be required in many instances, especially when high concentrations of respirable particulates are found in either (1) the outdoor air, such as in urban areas, or (2) the indoor air, where processes generate respirable particulates. Additional guidance could be developed to improve the filter selection process to remove a desirable range of particle sizes. Increasing particulate removal from duct air could decrease the amount of particulates that settle onto ductwork and provide growing areas for biological contamination. Little work has been done in this area, and more research would be required to determine the impacts, costs, and benefits of increased filtration, and before guidance could be developed.

The design of air filtration systems must satisfy Federal, state, and local standards, codes, and regulations. But there are few nationwide standards or guidelines for air cleaning systems, including USACE regulations. With ASHRAE 52-1976 superseded by ASHRAE 52.1-1992, CECS-15895 should be updated to comply with the current air filter test standard. Specifications of HEPA filters should include the requirement for leak testing in accordance with the IES recommended practice. TM 5-810-1 could be improved if detailed guidance on selecting the desired filtration system is included. Guidance to the Army Center for Public Works should address documentation on the proper operation and maintenance of air filters.

The performance of the HVAC equipment is vital to the proper functioning of the ventilation system. But, in many situations, the lack of standards for HVAC equipment and components hinders efficient functioning of the equipment. For example, accessibility to air filters frequently is difficult because of their placement in the AHU with respect to the access door; and air filters need to be changed or cleaned on a regular basis so the HVAC system functions properly.

The findings in this report also can serve as an update to existing, and possibly outdated, information on air cleaning systems.

Metric Conversion Factors

1 in.	=	25.4 mm
1 ft	=	0.305 m
1 sq ft	=	0.093 m ²
1 cu ft	=	0.028 m ³
1 lb	=	0.453 kg
1 ppm	=	(40.8998 × gas molecular weight) μg/m ³
1 in. wg	=	248.6 Pa
°F	=	(°C × 1.8) + 32

References

- American Conference of Governmental Industrial Hygienists (ACGIH), *Guide to Occupational Exposure Values—1994* (ACGIH, Cincinnati, OH, 1994).
- American Society of Heating, Refrigerating and Air-Conditioning Engineers, Inc. [ASHRAE] Standards Project Committee 62-1989, *Ventilation for Acceptable Indoor Air Quality*, ANSI/ASHRAE 62-1989 (ASHRAE, Atlanta, GA, 1990).
- Army Regulation [AR] 200-1, *Environmental Quality: Environmental Protection and Enhancement* (Headquarters, Department of the Army [HQDA], Washington, DC, 23 May 1990).
- ASHRAE Standards Project Committee 52.1P, *Gravimetric and Dust Spot Procedures for Testing Air-Cleaning Devices Used in General Ventilation for Removing Particulate Matter*, ANSI/ASHRAE 52.1-1992 (ASHRAE, Atlanta, GA, 1992).
- Bergman, W., "An Electric HEPA Filter," *Recent Investigations in Air Filtration* (Lawrence Livermore National Laboratory, Livermore, CA, 1990).
- Bergman, W., A.H. Biermann, S.R. Sawyer, and O.T. Martin, "Development of a High-Efficiency, High-Performance Air Filter Medium," *Recent Investigations in Air Filtration* (Lawrence Livermore National Laboratory, Livermore, CA, 1990).
- Bergman, W., A.H. Biermann, and S.R. Sawyer, "New Test Methods for Ultra-Low Penetration Aerosol (ULPA) Filters," *Recent Investigations in Air Filtration* (Lawrence Livermore National Laboratory, Livermore, CA, 1990).
- Brockmann, J.E., C.L.J. Adkins, and F. Gelbard, *Alternate Particle Removal Technologies for the Airborne Activity Confinement System at the Savannah River Site* (Westinghouse Savannah River Company, Aiken, SC, 1991).
- Burge, H.A., "Approaches to the Control of Indoor Microbial Contamination," *Proceedings IAQ 87: Practical Control of Indoor Air Problems* (Arlington, VA, May 18-20, 1987, ASHRAE, Atlanta, GA 1987).
- Carlson, H.R., M.A. Guelta, and B.V. Gerber, "Some Candidate Replacement Materials for Dioctyl Phthalate in 'Hot-Smoke' Aerosol Penetrometer Machines," *Aerosol Science and Technology*, vol 14, no. 2 (1991).
- Code of Federal Regulations (CFR) title 29, part 1910, section 1000.
- Code of Federal Regulations (CFR), title 40, part 50, sections 4, 5, 7, 8, 9, 11.

Code of Federal Regulations (CFR), title 40, part 50, section 6.

Corps of Engineers Guide Specification (CEGS) 15895, *Guide Specification for Military Construction* (Headquarters, U.S. Army Corps of Engineers [HQUSACE], Washington, DC, August 1991, revised September 1993).

Cutter Information Corporation, "Air Filters--How Effective Are They?" *Indoor Air Quality Update*, vol 4, no. 8 (August 1991).

Department of Defense Standard (DOD-STD) 35-41A(MI), *Automated Engineering Document Preparation System: Filters, Mechanical, Liquid, Gas/Air* (Department of Defense [DOD], Washington, DC, 2 February 1979, revised 30 June 1992).

Edge, C.A., "Indoor Air Quality--Lessons From Submarine Environmental Systems," *Proceedings IAQ 87: Practical Control of Indoor Air Problems* (ASHRAE, Arlington VA, May 18-20, 1987, ASHRAE, Atlanta, GA, 1987).

Energy Management Committee, *Indoor Air Quality* (Sheet Metal and Air Conditioning Contractors National Association [SMACNA], Vienna, VA, 1989).

Engineer Manual 385-1-1, *Safety and Health Requirements* (HQUSACE, Washington, DC, 1 October 1992).

Farr Company, *Filtration and Indoor Air Quality: A Two-Step Design Solution*, Bulletin No. T-200-17 (Farr Company, Los Angeles, CA, 1992).

Federal Specification F-F-2790, *Filter, Air-Extended Area, Initial Installation* (General Services Administration [GSA], Washington, DC, 27 November 1991).

Federal Specification F-F-1962, *Filter, Air Extended Media Area Type, for Use in Air Distribution System* (GSA, Washington, DC, 1 March 1978).

Fencl, F., "Air Filtration for IAQ Control," *Engineer's Digest*, vol 21, no. 9 (September 1993).

General Services Administration (GSA), "Air Cleaning--Section 15885," *GSA M/E Supplement to Masterspec* (GSA, October 1989).

Gilli, G., R. Bono, E. Scursatone, E. Guerrini, and E. Carrato, "Indoor, Outdoor and 'Personal Air' in Relation to Three Volatile Halogenated Hydrocarbons," *Indoor Air '90: Precedings of the 5th International Conference on Indoor Air Quality and Climate*, Volume 1 (International Conference on Indoor Air Quality and Climate, Toronto, ON, Canada, July 29-August 3, 1990, Canada Mortgage and Housing Corporation, Ottawa, ON, Canada, 1990).

- Guimond, R.J., S. Malm, and D. Rowson, "Radon in the United States: Accomplishments and Future Challenges," *Indoor Air '90: Precedings of the 5th International Conference on Indoor Air Quality and Climate*, Volume 5 (International Conference on Indoor Air Quality and Climate, Toronto, ON, Canada, July 29-August 3, 1990, Canada Mortgage and Housing Corporation, Ottawa, ON, Canada, 1990).
- Gupta, A., V.J. Novick, P. Biswas, and P.R. Monson, "Effect of Humidity and Particle Hygroscopicity on the Mass Loading Capacity of High Efficiency Particulate Air (HEPA) Filters," *Aerosol Science and Technology*, vol 19, no. 1 (July 1993).
- Hanley, J.T., D.D. Smith, and D.S. Ensor, *Define a Fractional Efficiency Test Method That Is Compatible With Particulate Removal Air Cleaners Used in General Ventilation* (Research Triangle Institute Center for Aerosol Technology, Research Triangle Park, NC, April 1993).
- Hansen, S.J., *Managing Indoor Air Quality* (The Fairmont Press, Inc., Lilburn, GA, 1991).
- Harrington, K., "Fibrous Particle Filtration," *Heating/Piping/Air Conditioning*, vol 65, no. 3 (March 1993).
- Information Handling Services (IHS), *Military Specifications and Standards: Locator Index* (IHS, Englewood, CO, 1994).
- Kelly, T.J., and D.A. Kinkead, "Testing of Chemically Treated Adsorbent Air Purifiers," *ASHRAE Journal*, vol 35, no. 7 (July 1993).
- Kennedy, C.R., and A. DiStefano, "Improving Building IAQ Reduces HVAC Energy Costs," *Heating/Piping/Air Conditioning*, vol 63, no. 11 (November 1991).
- Kunz, B., J. Ring, A. Grier, and K. Uberla, "Correlation Between Indoor Air Concentration of SO₂ and NO_x and Prevalence of Atopic Diseases in Children," *Indoor Air '90: Precedings of the 5th International Conference on Indoor Air Quality and Climate*, Volume 2 (International Conference on Indoor Air Quality and Climate, Toronto, ON, Canada, July 29-August 3, 1990, Canada Mortgage and Housing Corporation, Ottawa, ON, Canada, 1990).
- Liu, R., R.R. Raber, and H.H.S. Yu, "Filter Selection on an Engineering Basis," *Heating/Piping/Air Conditioning*, vol 63, no. 5 (May 1991).
- Masuda, S., S. Hosokawa, X.-L. Tu, M. Tsutsumi, T. Ohtani, T. Tsukahara, and N. Matsuda, "The Performance of an Integrated Air Purifier for Control of Aerosol, Microbial, and Odor," *IEEE Transactions on Industry Applications*, vol 29, no. 4 (July/August 1993).
- Matyas, B., "Residential Indoor Air Radon Levels in Rhode Island: Summary of State Experience to Date," *Indoor Air '90: Precedings of the 5th International Conference on Indoor Air Quality and Climate*, Volume 3 (International Conference on Indoor Air Quality and Climate, Toronto, ON, Canada, July 29-August 3, 1990, Canada Mortgage and Housing Corporation, Ottawa, ON, Canada, 1990).

- Meerman, J.J., and H.J.H. Brouwers, "Clean Pressure Drop of Non-Newtonian Liquid Flow Across Stacked-Disc Filters," *Chemical Engineering Science*, vol 48, no. 23 (December 1993).
- Military Specification MIL-F-0011137E(EA), *Filter, Gas, 150 CFM, M10* (HQDA, Washington, DC, 13 December 1989).
- Military Specification MIL-F-11150A, *Filter, Particulate, 150 CFM, ABC-M9* (HQDA, Washington, DC, 27 December 1961).
- Military Handbook MIL-HDBK-144, *Engineering Design Handbook for Air Cleaning for Chemical Demilitarization* (DOD, Washington, DC, 15 December 1978).
- Military Standard (MIL-STD) 282, *Military Standard: Filter Units, Protective Clothing, Gas-Mask Components and Related Products: Performance Test Methods* (DOD, Washington, DC, 28 May 1956, revised 10 February 1989).
- National Air Filtration Association (NAFA), *NAFA Guide to Air Filtration* (NAFA, Washington, DC, 1993).
- Newman, J.L., "HVAC System Performance and Indoor Air Quality," *Energy Engineering*, vol 88, no. 3 (1991), pp 61-78.
- News in Review, "Filtration System Clears the Air at World's Busiest Airport," *Consulting-Specifying Engineer*, vol 4, no. 4 (October 1988).
- O'Rourke, B., "Indoor Firing Range Ventilation System," *Heating/Piping/Air Conditioning*, vol 64, no. 10 (October 1992).
- Offermann, F.J., III, S.A. Loiselle, and R.G. Sextro, "Performance of Air Cleaners in a Residential Forced Air System," *ASHRAE Journal*, vol 34, no. 7 (July 1992).
- Offermann, F.J., III, R.G. Sextro, W.J. Fisk, D.T. Grimsrud, W.W. Nazaroff, A.V. Nero, K.L. Revzan, and J. Yater, "Control of Respirable Particles in Indoor Air With Portable Air Cleaners," *Atmospheric Environment*, vol 19, no. 11 (1985), pp 1761-1771.
- Otani, Y., H. Emi, J. Mori, and H. Nishino, "Fundamental Study on the Simultaneous Removal of Gaseous and Particulate Matters in Room Environment by Fibrous Filters," *Journal of Aerosol Science*, vol 22, Supplement 1 (1991).
- Ottney, T.C., "Particle Management for HVAC Systems," *ASHRAE Journal*, vol 35, no. 7 (July 1993).
- Ottney, T.C., "Helping Users With a Universal Air Filter Classification System," *ASHRAE Journal*, vol 35, no. 9 (September 1993).
- Parsons, R.A., ed., *1992 ASHRAE Handbook: HVAC Systems and Equipment* (ASHRAE, Atlanta, GA, 1992).
- Parsons, R.A., ed., *1991 ASHRAE Handbook: HVAC Applications* (ASHRAE, Atlanta, GA, 1991).

Plett, E.G., F. Vaculik, and C.Y. Shaw, *Controlling Indoor Air Quality: Ventilation Engineering Guide* (National Research Council [NRC] of Canada [in collaboration with Public Works Canada Realty Services], Ottawa, ON, Canada, 1992).

Rodberg, J.A., J.F. Miller, G.E. Keller, and J.E. Woods, "A Novel Technique to Permanently Remove Indoor Air Pollutants," *[Proceedings] IAQ 91: Healthy Buildings* (ASHRAE, Washington, DC, September 4-8, 1991, ASHRAE, Atlanta, GA, 1991).

Secretary of State, *Illinois Administrative Code: Environmental Protection*, Title 35, Subtitle B, Chapter I (State of Illinois, Springfield, IL (1992).

Shaughnessy, R.J., and L. Oatman, "The Use of Ozone Generators for the Control of Indoor Air Contaminants in an Occupied Environment," *[Proceedings] IAQ 91: Healthy Buildings* (ASHRAE, Washington, DC, September 4-8, 1991, ASHRAE, Atlanta, GA, 1991).

Stenhouse, J.I.T., and R. Trottier, "The Loading of Fibrous Filters with Submicron Particles," *Journal of Aerosol Science*, vol 22, Supplement 1 (1991).

Technical Bulletin MED 502, Defense Logistics Agency Manual (DLAM) 1000.2, *Occupational and Environmental Health: Respiratory Protection Program* (HQDA, Washington, DC, February 1982).

Technical Manual (TM) 5-855-4, *Heating, Ventilation, and Air Conditioning of Hardened Installations* (HQDA, Washington, DC, November 1986).

TM 5-810-1, *Mechanical Design: Heating, Ventilating, and Air-Conditioning* (HQDA, Washington, DC, 15 June 1991).

US Environmental Protection Agency (USEPA), *Building Air Quality: A Guide for Building Owners and Facility Managers*, EPA/400/1-91/033 (USEPA, Washington, DC, December 1991).

USEPA, *National Air Quality and Emissions Trends Report, 1992*, EPA/454/R-93/031 (Office of Air and Radiation, Office of Air Quality Planning and Standards, USEPA, Research Triangle Park, NC, October 1993).

Viner, A.S., P.A. Lawless, D.S. Ensor, and L.E. Sparks, "Ozone Generation in dc-Energized Electrostatic Precipitators," *IEEE Transactions on Industry Applications*, vol 28, no. 3 (May/June 1992).

Appendix A: Specifications Relating to Particulate Filtration

Technical Manual TM 5-810-1, Paragraph 2-5 on Filtration *

“For administrative facilities, commercial facilities, and similar occupancies where indoor air quality is of primary concern, the combined supply air, including return and outside air, will be filtered by a combination of 25 to 30 percent efficient prefilter(s) and 80 to 85 percent efficient final filter(s) as determined by the dust spot test specified in ASHRAE Standard 52. Due to the decrease in system airflow as the pressure drop across the filters increases, fans should be sized for the ‘dirty’ filter condition. This will ensure that the fan has adequate capacity to deliver the design airflow as the filter becomes loaded. In addition, in order to ensure that this fan capacity is ‘available,’ test and balance criteria in the appropriate Corps of Engineers Guide Specification (CEGS) requires that actual airflows after balancing are greater than (typically up to 10 percent) or equal to those shown on the drawings.”

Excerpts From Federal Specification F-F-1962**

The following is a list of specifications for an air extended media area type filter “with externally supported, non-supported, or self-supporting cartridges installed in permanent corrosion resistant metal holding frames or housings for removal of particulate matter in air-conditioning, heating and ventilating systems.”

Under Section 1.2:

“All filters shall be UL (Underwriters’ Laboratories) approved, class 2 conforming to UL 900. Filters shall be of the following type cartridges and media grades”:

* Source: Technical Manual 5-810-1, June 1991, p 2-2.

** Source: Federal Specification F-F-1962, March 1978.

Cartridges

Type I - Prefilter - Externally supported or non-supported cartridge (bag type).

Type II - Afterfilter - Externally supported or non-supported cartridge (bag type).

Media

Grade A - 95 percent rated efficiency (ASHRAE Std. 52-76 using atmospheric dust).

Grade B - 85 percent rated efficiency (ASHRAE Std. 52-76 using atmospheric dust).

Grade C - 40 percent rated efficiency (ASHRAE Std. 52-76 using atmospheric dust).

Grade D - 30 percent rated efficiency (ASHRAE Std. 52-76 using atmospheric dust).

Under Section 3.1.1.1, each filter shall consist of a "permanent 16 gauge metal or heavier corrosion resistant holding frame with suitable cartridge or media retainer springs, clips or latches along with cartridge supporting wirework and gaskets."

"There shall be no air leakage between permanent holding frame and cartridge that may cause air to bypass filter.... After filter holding frames or housings for filters serving operating rooms shall be aluminum. After filter holding frames or housings for filters used for applications other than operating rooms shall be galvanized metal."

Under Section 3.1.1.2:

"A preformed, sealed and disposable cartridge of the pleated or extended area type rated UL class 2, shall be furnished for type I, grades C and D, and type II, grades A and B filters.... Media for grade C shall be composed of thin glass fibers laid in a thin felt bonded with phenolic resin.... Flow resistance for grade C material shall not be more than 0.08 inches w.g. (water gauge) measured on flat sheets at 35 rpm velocity.... As an alternate, media for grade C may be a synthetic cotton fiber with a layer of synthetic material on clean air side, securely bonded.... Flow resistance shall be not be less than 0.04 inches w.g. measured on flat sheets at 70 rpm velocity.... Media for grade D filters shall be of synthetic fibers with a PVC binder.... Maximum resistance for grade D material shall not be more than 0.10 inches w.g. measured on flat sheets at 200 rpm...."

Media for grades A and B "shall be composed of thin glass fibers laid in a thin felt bonded with phenolic resin.... Flow resistance for grade A material shall not be more than 0.52 inches w.g. and for grade B material not more than 0.24 inches w.g. measured on flat sheets at 35 rpm velocity...."

Under Section 3.1.1.3:

“With clean filters, the initial pressure drop shall not exceed the values listed [in Table A1] at the given face velocities at the filter’s rated capacity.... The final pressure drop and dust holding capacity of each filter cartridge when operated at rated capacity shall not exceed the following [values listed in Table A2).... Efficiency of filters shall be determined in accordance with ASHRAE Std. 52-76 using atmospheric dust. Efficiency shall not be less than the following [values listed in Table A3].”

Under Section 3.1.1.4, filters must have “one direct reading draft gauge per filter bank complete with static tips and necessary accessory items to provide zero adjustment and accurate operation.”

Table A1. Initial pressure drop of air extended media area type filters.

Media Type Filter	500 fpm (Face Velocity) (in. wg)	625 fpm (Face Velocity) (in. wg)
Grade A	0.65	0.70
Grade B	0.42	0.50
Grade C	0.35	0.45
Grade D	0.35	0.45

Source: Federal Specification F-F-1962, March 1978.

Table A2. Final pressure drop of air extended media area type filters.

Media Type Filter	500 fpm (Face Velocity) (in. wg)	625 fpm (Face Velocity) (in. wg)
Grade A	1.00	1.20
Grade B	1.00	1.20
Grade C	0.80	1.00
Grade D	0.70	0.80

Source: Federal Specification F-F-1962, March 1978.

Table A3. Air extended media area type filter efficiencies.

Media Type Filter	Initial Filter Efficiency (percent)	Average Filter Efficiency (percent)
Grade A	80	88
Grade B	58	75
Grade C	15	30
Grade D	10	20

Source: Federal Specification F-F-1962, March 1978.

Excerpts From Federal Specification F-F-2790*

The following is a list of specifications for replaceable, extended media area type air filters "with externally supported, nonsupported, or self-supporting cartridges installed in permanent metal holding frames and housings as required for use in air conditioning, heating, and ventilating systems":

Under Section 1.2:

"Filters covered by this specification shall be of the following types and grades":

Type I - Prefilter - Externally supported or nonsupported cartridge.

Grade A - 30 percent commercially rated efficiency

Grade B - 40 percent commercially rated efficiency

Type II - Afterfilter - Externally supported or nonsupported cartridge.

Grade C - 85 percent commercially rated efficiency (minimum of 58 percent per ASHRAE 52 using atmospheric dust)

Grade D - 95 percent commercially rated efficiency (minimum of 78 percent per ASHRAE 52 using atmospheric dust)

Type III - Afterfilter - Self-supported cartridge

Grade E - 95 percent rated efficiency (Diocetyl Phthalate (DOP) Test using 0.3 micron particles)

Grade F - 99.97 percent rated efficiency (DOP Test using 0.3 micron particles)

* Source: Federal Specification F-F-2790, November 1991, pp 1-15.

Under Section 3.4:

“Materials used shall be free from defects which would adversely affect the performance or maintainability of individual components of the overall assembly.... Galvanized and galvanized sheet steel shall conform to ASTM A 525. The weight of zinc coating for galvanized steel media shall not be less than that specified in ASTM B 633 for type LS electroplate zinc coating.... Aluminum shall be an alloy conforming to the requirements of ASTM B 209.... Corrosion-resistant steel shall conform to any of the 300- or 400-series of ASTM A 167 or A 176, as applicable.... Aluminum-coated steel sheets shall be coated with aluminum on both sides by the hot-dip process. The total weight of coating on both sides of the sheet shall be not less than 0.40 ounces per square foot (122 grams per square meter) of sheet.... Joints between dissimilar metals, including bolts, nuts, rivets, and other fastenings and fittings shall be protected against galvanic corrosion by the proper selection of materials, plating isolation, insulation, area relationships or other means, providing equivalent protection.”

Under Section 3.5:

“Filters shall meet the fire-resistant requirements of UL 900. Filters shall be either UL Class 1 or UL Class 2, at the option of the contractor, unless UL Class 1 filters only are specified in the invitation for bids. Classifications under UL 900 shall be interpreted as follows:

“Class 1 - Filters, which, when clean, do not contribute fuel when attacked by flame and emit only negligible amounts of smoke.

“Class 2 - Filters, which, when clean, burn moderately when attacked by flame or emit moderate amounts of smoke or both.

“Adhesive coatings used on filters shall have a flashpoint of not less than 325 degrees Fahrenheit (163 degrees Centigrade) as determined by ASTM D 92.”

Under Section 3.6:

“The media shall be nontoxic and without any detectable odor....”

Under Section 3.7.1 for Type I and Type II filters:

“When specified, each filter shall be furnished with a permanent holding frame, the frame shall be manufactured of not less than 16-gage material.... a factory assembled side or a bottom access filter housing(s), with a nominal 2-inch prefilter track, shall be

provided. The housing(s) shall be manufactured of minimum 16-gage material.... A preformed, close-pleated replaceable type filter cartridge shall be provided. The filter cartridge shall consist of a frame, media, fire-retardant sealers, and a gasket on downstream face, where required, to prevent any air bypass leakage. If separators are provided, they shall be aluminum.”

Under Section 3.8:

“One direct reading draft gage shall be furnished with each filter bank complete with tips and necessary accessory items to provide zero adjustment and accurate operation.”

The filter performance requirements for type I and type II filters are specified in Section 3.9 as:

“With clean filters, the average initial pressure drop ... measured in inches water gage (wg) (Pascals (Pa)), shall not exceed the values listed [in Table A4] at the specified rated airflow capacity, measured in cubic feet per minute (cfm) (cubic meters per hour (cu m/hr)).... The final pressure drop of each filter cartridge, when operated at rated airflow capacity, shall not exceed the following [values listed in Table A5] ... The average synthetic dust weight arrestance shall not be less than the following [values indicated in Table A6] ... The average dust spot efficiency shall not be less than the following [values listed in Table A7] ... The average dust holding capacity shall not be less than the following [values listed in Table A8].”

Under Section 3.10 for Type III filters:

“With clean filters, the initial pressure drop shall not exceed the values listed [in Table A9] at the given rated air flow capacity.... The final pressure drop of each filter, when operated at rated capacity, shall not exceed the following [values listed in Table A10]. ... The efficiency of the type III filters shall be determined in accordance with MIL-STD 282 using 0.3 micron particle of thermally generated DOP smoke and shall not be less than the following [values listed in Table A11].”

Table A4. Initial pressure drop of Type I and II air-extended area filters.

Grade	1,500 cfm (2,550 m ³ /hr)	2,000 cfm (3,400 m ³ /hr)	2,500 cfm (4,250 m ³ /hr)
A	0.25 in. wg (62.5 Pa)	0.30 in. wg (75.0 Pa)	0.40 in. wg (100.0 Pa)
B	0.25 in. wg (62.5 Pa)	0.35 in. wg (87.5 Pa)	0.45 in. wg (112.5 Pa)
C	0.40 in. wg (100.0 Pa)	0.45 in. wg (112.5 Pa)	0.55 in. wg (137.5 Pa)
D	0.55 in. wg (137.5 Pa)	0.60 in. wg (150.0 Pa)	0.65 in. wg (162.5 Pa)

Source: Federal Specification F-F-2790, November 1991, p 6.

Table A5. Final pressure drop of Type I and II air-extended area filters.

Grade	1,500 cfm (2,550 m ³ /hr)	2,000 cfm (3,400 m ³ /hr)	2,500 cfm (4,250 m ³ /hr)
A	0.70 in. wg (175.0 Pa)	0.70 in. wg (175.0 Pa)	0.80 in. wg (200.0 Pa)
B	0.80 in. wg (200.0 Pa)	0.80 in. wg (200.0 Pa)	1.00 in. wg (250.0 Pa)
C	1.00 in. wg (250.0 Pa)	1.00 in. wg (250.0 Pa)	1.00 in. wg (250.0 Pa)
D	1.00 in. wg (250.0 Pa)	1.00 in. wg (250.0 Pa)	1.20 in. wg (300.0 Pa)

Source: Federal Specification F-F-2790, November 1991, p 7.

Table A6. Average synthetic dust weight arrestance of Type I and II air-extended area filters (in percent).

Grade	1,500 cfm (2,550 m ³ /hr)	2,000 cfm (3,400 m ³ /hr)	2,500 cfm (4,250 m ³ /hr)
A	85	85	85
B	94	94	94
C	98	99	99
D	100	100	100

Source: Federal Specification F-F-2790, November 1991, p 7.

Table A7. Average dust spot efficiency for Type I and II air-extended area filters.

Grade	Initial Efficiency (percent)	Average Efficiency (percent)
A	Less than 20	Less than 20
B	Less than 20	35
C	58	76
D	78	88

Source: Federal Specification F-F-2790, November 1991, p 7.

Table A8. Average dust holding capacity for Type I and II air-extended area filters (in grams).

Grade	1,500 cfm (2,550 m ³ /hr)	2,000 cfm (3,400 m ³ /hr)	2,500 cfm (4,250 m ³ /hr)
A	600	1,000	1,000
B	500	600	700
C	300	400	470
D	220	300	380

Source: Federal Specification F-F-2790, November 1991, p 7.

Table A9. Initial pressure drop for Type III air-extended area filters.

Grade	6-in. depth 650 cfm (1,105 m ³ /hr)	12-in. depth 1,000 cfm (1,700 m ³ /hr)
E	1.0 in. wg (250.0 Pa)	1.0 in. wg (250.0 Pa)
F	1.0 in. wg (250.0 Pa)	1.0 in. wg (250.0 Pa)

Source: Federal Specification F-F-2790, November 1991, p 7.

Table A10. Final pressure drop of Type III air-extended area filters.

Grade	6-in. depth 650 cfm (1,105 m ³ /hr)	12-in. depth 1,000 cfm (1,700 m ³ /hr)
E	2.0 in. wg (500.0 Pa)	2.0 in. wg (500.0 Pa)
F	2.0 in. wg (500.0 Pa)	2.5 in. wg (625.0 Pa)

Source: Federal Specification F-F-2790, November 1991, p 8.

Table A11. Efficiency of Type III air-extended area filters.

Grade	Initial Efficiency (percent)
E	95
F	99.97

Source: Federal Specification F-F-2790, November 1991, p 8.

In terms of dimensions, Section 3.11 states:

“Unless otherwise specified, the actual outside face dimensions of the holding frame shall be 24 inch by 24 inch (610 millimeters (mm) by 610 mm) and with the depth as manufacturer’s standard. The nominal face dimensions of the filter cartridge shall be 23.5 inch by 23.5 inch (598 mm by 598 mm) with the depth as required by design to comply with the requirements as specified in 3.7. The actual face dimension of the cartridge shall be not less than 1/4 inch (6 mm) in either width or length from the nominal media face dimensions (for grades A through E). Grade F filter cartridge dimension shall be 24.0 inch (610 mm) by 24.0 inch (610 mm), +0 inch (+0 mm), -1/16 inch (-2 mm), including the header frame, and depth as required by design.”

In terms of workmanship, Section 3.15 states:

“The steel used in fabrication shall be free from kinks, sharp bends, and other conditions which would be deleterious to the finished product.... Boltholes shall be accurately punched or drilled and shall have the burrs removed. Washers or lockwashers shall be provided in accordance with good commercial practice, and all

bolts, nuts, and screws shall be tight.... Rivet holes shall be accurately punched or drilled and shall have the burrs removed. Rivets shall be driven with pressure tools and shall completely fill the holes.... The surface of parts to be welded shall be free from rust, scale, paint, grease, or other foreign matter....”

Excerpts From Military Specification MIL-F-11150A*

The following is a list of MIL-F-11150A specifications for an ABC-M9 particulate filter operating at a rated flow rate of 150 cfm:

Under Section 3.3:

“The resistance to airflow through the filter shall not exceed 1.0 inch of water at an airflow of 150 cubic feet per minute (cfm)”

Under Section 3.4:

“The DOP smoke penetration of the filter shall not exceed 0.03 percent”

Under Section 3.5:

“The filter shall comply with the resistance to airflow and DOP smoke penetration requirements of 3.3 and 3.4 after rough handling”

Under Section 3.6:

“Damage, such as bent, warped, or burred metal sections, and contamination of the surface with foreign substances, such as oily and viscous liquids, shall be indicative of bad workmanship and not allowed.”

Excerpts From CEGS-15895, Part 2.9.3 on Air Filters**

The following section addresses current detailed Corps guidance on air filters in HVAC air supply and distribution systems.

* Source: Military Specification MIL-F-11150A, December 1961.

** Source: Corps of Engineers Guide Specification 15895, September 1993.

General Specifications

Part 2.9.3 provides general specifications on air filters in the following manner:

“Air filters shall be listed in accordance with requirements of UL 900, except high efficiency particulate air filters of 99.97 percent efficiency by the DOP Test method shall be as listed under the Label Service and shall meet the requirements of UL 586.”

Additional Note K is referenced in Part 2.9.3 and reads:

“In the event the retention of efficiency values in the specification becomes cumbersome, the requirements may be revised by referring to the efficiencies indicated on the drawings, to show for each air handling unit or system the efficiency of the air filters required, and the maximum initial resistance.

“Filters should be selected based on the functional needs of the area served, including indoor air quality. The combination of the extended surface pleated panel filters and the extended surface nonsupported pocket filters are intended to fulfill the filtration requirements in TM 5-810-1, Heating, Ventilating, and Air-Conditioning for areas where indoor air quality is of primary concern.”

On the design of holding frames, section 2.9.3.8 states:

“Frames shall be fabricated from not lighter than 16-gauge sheet steel with rust-inhibitor coating. Each holding frame shall be equipped with suitable filter holding devices. Holding frame seats shall be gasketed. All joints shall be airtight.”

On the use of filter gauges, section 2.9.3.9 cites:

“Filter gauges shall be dial type, diaphragm actuated draft and shall be provided for all filter stations, including those filters which are furnished as integral parts of factory fabricated air handling units. ... Each gauge shall incorporate a screw operated zero adjustment and shall be furnished complete with two static pressure tips with integral compression fittings, two molded plastic vent valves, two 5-foot minimum lengths of 1/4-inch diameter (aluminum or vinyl) tubing, and all hardware and accessories for gauge mounting.”

Electrostatic Filters

The following excerpts are from specifications on electrostatic filters in Part 2.9.3.6:

“Electrostatic filters shall be the combination dry agglomerator/extended surface nonsupported pocket filter or the combination dry agglomerator/automatic renewable media (roll) type.... Each dry agglomerator electrostatic air filter shall be supplied with the correct quantity of fully housed power packs and equipped with silicon rectifiers, manual reset circuit breakers, low voltage safety cutout, relays for field wiring to remote indication of primary and secondary voltages, and lamps mounted in the cover to indicate these functions locally.... Ozone generation within the filter shall not exceed five parts per one hundred million parts of air....

“Initial air flow resistance of the dry agglomerator/renewable media combination, after installation of clean media, shall not exceed 63 Pa (0.25-inch water gauge) at 2.5 m per second (500 fpm) face velocity. Minimum atmospheric air dust spot efficiency of the combination shall be not less than 90 percent when tested in accordance with ASHRAE 52 at an average operating resistance of 125 Pa (0.50-inch water gauge).... Initial air flow resistance of the dry agglomerator/extended surface nonsupported pocket filter sector combination, after installation of clean filters, shall not exceed 162 Pa (0.65-inch water gauge) at 2.5 m per second (500 fpm) face velocity. Minimum atmospheric air dust spot efficiency of the combination shall be not less than 95 percent when tested in accordance with ASHRAE 52....”

HEPA Filters

The following excerpts are from specifications on HEPA filters in Part 2.9.3.7:

“HEPA filters shall be individually tested and certified to have an efficiency of not less than [95] [99.97] percent when tested with 0.3 micron dioctylphthalate (DOP) smoke in accordance with MIL-STD 282 ... [Filters of 95 percent efficiency shall conform to MS MIL-F-29177, Type III, Grade E.] [Filters of 99.97 percent efficiency shall conform to MS MIL-F-51068.].... Filters shall be constructed by pleating a continuous sheet of filter medium into closely spaced pleats separated by corrugated aluminum or mineral-fiber inserts, strips of filter medium, or by honeycomb construction of the pleated filter medium.... Filter cell sides shall be [20 mm (3/4-inch) thick exterior grade [fire-retardant plywood] [cadmium plated steel] [galvanized steel] assembled in a rigid manner. Overall cell side dimensions shall be correct to 1.6 mm... (1/16 in.) and squareness shall be maintained to within 3.2 mm... (1/8 in.)....”

An additional note is given in Part 2.9.3.7 as Note L:

“High-efficiency particulate air filters will be used in CLEAN ROOMS (White Rooms or Dust Controlled Facilities), clean work stations, and for critical areas of hospitals. The efficiency of the prefilter will be indicated on the drawings to suit the anticipated contamination load and the deg (degree) of prefiltration efficiency required.”

Replaceable Media Filters

The following excerpts are from specifications on replaceable media filters in Part 2.9.3.4:

“Replaceable media filters shall be the dry-media/viscous adhesive type, of the size required to suit the application. Filtering media shall be not less than 50 mm (2 in) thick fibrous glass media pad supported by a structural wire grid or woven wire mesh. Pad shall be enclosed in a holding frame of not less than 1.613 mm (16-gauge) galvanized steel, and equipped with quick-opening mechanism for changing filter media. The air flow capacity of the filter shall be based on net filter face velocity not exceeding [1.5 m per second (300 fpm)..., with initial resistance of [32 Pa (0.13 in. w. gauge)....”

Automatic Renewable Media Filters

The following excerpts are from specifications on automatic renewable media filters in Part 2.9.3.5:

“Automatic, renewable media filters shall consist of a horizontal or vertical traveling curtain of adhesive-coated bonded fibrous glass supplied in convenient roll form. Operation and maintenance requirements of the filter shall not require water supply, sewer connections, adhesive reservoir, or sprinkler equipment. Basic frame shall be fabricated of not less than 1.994 mm (14-gauge) galvanized steel.... Media shall be rolled or enclosed in such a way that collected particulates will not re-entrain (or to draw in and transport again by fluid flow).... Media shall be of continuous, bonded fibrous glass material, shall be UL Class 2, and shall not compress more than 6.4 mm (1/4 in.) when subjected to air flow at 2.5 meters per second (500 fpm).... Media shall be factory charged with an odorless and flame retardant [sic] adhesive which shall not flow while in storage nor when subjected to temperatures up to 80 degrees C (175 degrees F).... Media shall be supported on both the leaving and entering air faces. The initial resistance of the clean media shall not exceed 45 Pa (0.18-inch water gauge) at its rated velocity of 2.5 meters per second (500 fpm).... Dust holding capacity per square foot of media area ... shall be at least 5.4 kg per square meter (55 grams per

sq ft) of ASHRAE Standard Test Dust per sq ft of media when tested in accordance with the dynamic testing provisions of ASHRAE 52 when operating at a steady state with an upper operating resistance of 125 Pa (0.50-inch water gauge). Average arrestance under these conditions shall be 80 percent....”

Extended Surface Pleated Panel Filters

The following excerpts are from specifications on automatic renewable media filters in Part 2.9.3.1:

“Filters shall be 50 mm (2-inch) depth, sectional, disposable type of the size indicated and shall have an average efficiency of 25 to 30 percent when tested in accordance with ASHRAE 52. Initial resistance at 2.5 meters per second (500 fpm)... will not exceed 90 Pa (0.36 inches water gauge)... Filters shall be UL Class 2. Media shall be nonwoven cotton and synthetic fiber mat....”

Extended Surface Nonsupported Pocket Filters

The following excerpts are from specifications on extended surface nonsupported pocket filters in Part 2.9.3.2:

“Filters shall be [750 mm (30 inch)]... depth, sectional, replaceable dry media type of the size indicated and shall have an average efficiency of 80 to 85 percent when tested in accordance with ASHRAE 52. Initial resistance at [2.5 meters per second (500 fpm)]... shall not exceed [112 Pa (0.45 inches water gauge)]... Media shall be fibrous glass, supported in the air stream by a wire or non-woven synthetic backing and secured to a galvanized steel metal header. Pockets shall not sag or flap at anticipated air flows. Each filter shall be installed [with an extended surface pleated panel filter as a prefilter] in a factory preassembled, side access housing or a factory-made sectional frame bank, as indicated.”

Appendix B: Specifications Relating to Gas-Phase Filtration

Excerpts From Military Specification MIL-F-0011137E(EA)*

The following list of requirements is specified for an M10 gas filter with a rated flow of 150 cfm:

Under Section 3.1.1.1:

“The fines filter cotton cloth shall be made fungus resistant in accordance with MIL-F-46032 ... The cotton cloth shall have a minimum spray rating of 50.0 when tested in accordance with method 5526 of FED-STD 191.”

Under Section 3.3.1:

“The airflow resistance of the gas filters shall be 4.5 ± 0.5 inches of water at an airflow rate of $150 \text{ cfm} \pm 10 \text{ cfm}$ at $75^\circ \pm 5^\circ\text{F}$ and 30 percent maximum relative humidity”

Under Section 3.3.2:

“The gas filter shall not leak when a concentration of 1000 parts per million (ppm) of dichlorodifluoromethane refrigerant (R-12) ... in air at $75^\circ \pm 5^\circ\text{F}$ and 30 percent maximum relative humidity is introduced at the influent side of the filter at one-fifth the rated airflow of the filter.... A filter leak shall be defined as the detection of 1 ppm or more of R-12 at the effluent side of the filter within 2 minutes after the introduction of R-12 at the influent side.”

Under Section 3.3.3:

“The gas filter shall be rough handled in the upright position for 15 minutes.... After rough handling, the gas filter shall show no evidence of cracks, dents, or charcoal leakage; the airflow resistance shall comply with 3.3.1 ... the filter shall not permit

* Source: Military Specification MIL-F-0011137E(EA), December 1989).

penetration of 0.04 micrograms or more of DMMP (dimethylmethylphosphonate) per liter of air within a minimum of 75 minutes.”

Under Section 3.5:

“The gas filter shall be free from chipped, burred, or bent metal sections, ripped or torn cloth, abraded gaskets, and foreign matter (dirt, oily or viscous material).”

Under Section 4.4.4.1:

“Moisture content of the charcoal sorbent shall be determined according to ASTM D 2867.”

Appendix C: Research Projects

The following summary of research projects are from the source cited at the end of each item.

Matching Filtration to Health Requirements

Four primary test sites were used to conduct the following: (1) laboratory tests on two types of media filters and one electrostatic precipitator with 100 percent outside air, (2) laboratory tests on two types of media filters and one electrostatic precipitator at controlled temperature and humidity, (3) residential field tests using an electrostatic precipitator, and (4) commercial office building field tests using a media filter. Among the observations noted in the study were: (1) filter efficiency on 10 μm particles is similar to bioaerosol efficiency, (2) outside bioaerosol levels increase in higher magnitude than indoor levels in both commercial and residential buildings, and (3) all three filter types--two media filters and one electrostatic precipitator--show a high efficiency on fungi and bacteria. (T.H. Kuehn, D.Y.H. Pui, D. Vesley, A. Streifel, S.J. Kemp, and J. Marx, *Matching Filtration to Health Requirements*, Phase 2 Interim Report, ASHRAE RP-625 [The American Society of Heating, Refrigerating, and Air-Conditioning Engineers, University of Minnesota, Minneapolis, MN, June 27, 1993].)

Determination of Air Filter Performance Under Variable Air Volume Conditions

The prediction of variable air volume (VAV) performance from the basic geometry of both full-scale and media filters is limited by three factors: (1) randomness in the geometry of full-scale and flat-sheet media filter structures, (2) buildup of dust in pleated filter structures on pleat crests (upstream) and in pleat valleys (downstream) as a possible result of inertial impaction by large particles, and (3) increased computational burden if making attempts to include either of these effects in the VAV filtration model. Fluorescent aerosols were used to characterize flat-sheet and full-scale filter media and examine the gross deposition of dust in filter structures. (R.D. Rivers and D.J. Murphy, Jr., *Determination of Air Filter Performance Under Variable Air Volume (VAV) Conditions: Phase II Progress Report* [Environmental Quality

Sciences, Inc., Louisville, KY, and Air Filter Testing Laboratories, Inc., Crestwood, KY, Mimeo, June 24, 1993].)

Investigate and Identify Indoor Allergens and Biological Toxins That Can Be Removed by Filtration

The objectives are to: (1) study the characteristics of the indoor allergens and biological toxins described in medical and microbiological literature, (2) examine current sampling methods used to quantify and identify these allergens and biological toxins, and (3) evaluate filtration techniques used to remove these biological particles. Among the research needs and recommendations proposed from this study are: (1) investigate the size-dependent local concentrations of indoor allergens, (2) examine aerosol transport indoors under normal comfort HVAC conditions, (3) study allergen and aerosol behavior through HVAC systems, and (4) quantitatively estimate the effectiveness of air cleaning on allergen exposure. (K.K. Foarde, D.W. VanOsdell, and J.J. Fischer, *Investigate and Identify Indoor Allergens and Biological Toxins That Can Be Removed by Filtration*, ASHRAE RP-760 [Research Triangle Institute, Research Triangle Park, NC, January 22, 1994].)

Evaluation of Test Methods for Determining the Effectiveness and Capability of Gas Phase Air Filtration Equipment for Indoor Air Application

The purpose of this project is to develop standard test methods for full-scale gas-phase air filtration equipment used in nonindustrial building applications. A small-scale test apparatus is used to evaluate the adsorption media performance of gas-phase air filtration equipment economically. With the small-scale test apparatus used as a prototype, the full-scale model will be constructed upon complete testing of the small-scale experiment. The full-scale gas-phase testing apparatus will consist of three main sections: (1) a gas-phase contaminant clean-up section, (2) a contaminant injection system, and (3) a control unit for temperature and relative humidity. (D.W. VanOsdell, *Evaluation of Test Methods for Determining the Effectiveness and Capability of Gas Phase Air Filtration Equipment for Indoor Air Application. Phase II: A Laboratory Study To Support the Development of Standard Test Methods* [Research Triangle Institute, Research Triangle Park, NC, December 1993].)

Abbreviations and Acronyms

ACF	activated carbon fiber
ACGIH	American Conference of Governmental Industrial Hygienists
AHU	air-handling unit
ASHRAE	American Society of Heating, Refrigerating and Air-Conditioning Engineers
CAA	Clean Air Act
CBR	chemical, biological, and radiological
cfm	cubic feet per minute
cm ²	square centimeter
DOP	dioctylphthalate
EAC	electronic air cleaner
ECR	effective cleaning rate
fpm	feet per minute
ft	feet
HEPA	high efficiency particulate air
HVAC	heating, ventilating, and air-conditioning
IAQ	indoor air quality
IHS	Information Handling Services, Inc.
in.	inch
in. wg	inch water gauge
kV	kilovolts
lb	pound
m ³	cubic meter
mg	milligram

μg	microgram
μm	micrometer
mm Hg	millimeters mercury
mrem	milliroentgen equivalent man
MPPS	most penetrating particle size
NAAQS	National Ambient Air Quality Standards
OSHA	Occupational Safety and Health Administration
PAH	polycyclic aromatic hydrocarbon
PAO	poly-alpha olefin
ppb	parts per billion
ppm	parts per million
pCi/L (or l)	pico Curies per liter
PROSPECT	Proponent Sponsored Engineer Corps Training
SMACNA	Sheet Metal and Air Conditioning Contractors National Association
sq ft	square foot
STEL	short-term exposure limit
TLV	threshold limit value
TWA	time-weighted average
UL	Underwriters' Laboratories
ULPA	ultra low penetrating air
USACE	U.S. Army Corps of Engineers
USACERL	U.S. Army Construction Engineering Research Laboratories
USEPA	U.S. Environmental Protection Agency
VAV	variable air volume
VOC	volatile organic compounds