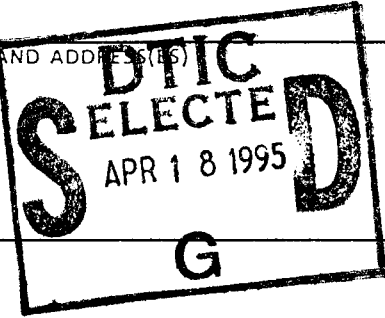

REPORT DOCUMENTATION PAGE

Form Approved
OMB No. 0704-0188

Public reporting burden for this collection of information is estimated to average 1 hour per response, including the time for reviewing instructions, searching existing data sources, gathering and maintaining the data needed, and completing and reviewing the collection of information. Send comments regarding this burden estimate or any other aspect of this collection of information, including suggestions for reducing this burden, to Washington Headquarters Services, Directorate for Information Operations and Reports, 1215 Jefferson Davis Highway, Suite 1204, Arlington, VA 22202-4302, and to the Office of Management and Budget, Paperwork Reduction Project (0704-0188), Washington, DC 20503.

1. AGENCY USE ONLY (Leave blank)	2. REPORT DATE 3/15/95	3. REPORT TYPE AND DATES COVERED Annual Technical Report, Nov. 1991 - Oct. 1994	
4. TITLE AND SUBTITLE Energy Transfer Dynamics in Isolated and Colliding Highly Vibrationally Excited Molecules		5. FUNDING NUMBERS 61102F 2303 ES	
6. AUTHOR(S) F. Fleming Crim			
7. PERFORMING ORGANIZATION NAME(S) AND ADDRESS(ES) University of Wisconsin 750 University Avenue Madison, WI 53706-1490		8. PERFORMING ORGANIZATION REPORT NUMBER AFOSR-TR-95-0251	
9. SPONSORING/MONITORING AGENCY NAME(S) AND ADDRESS(ES) AFOSR/HEML Building 410, Bolling AFB DC 20332-6448 <i>Dr. Berman</i>		10. SPONSORING/MONITORING AGENCY REPORT NUMBER F49620-92-J-0040	
			
11. SUPPLEMENTARY NOTES			
12a. DISTRIBUTION/AVAILABILITY STATEMENT APPROVED FOR PUBLIC RELEASE; DISTRIBUTION IS UNLIMITED		12b. DISTRIBUTION CODE 19950417 144	
13. ABSTRACT (Maximum 200 words) The flow of energy in molecules, either isolated or colliding, is fundamental to complex phenomena occurring in atmospheric chemistry, combustion, molecular lasers, plasmas, and a host of other environments containing energetic species. We have developed, proven, and applied a technique that combines vibrational overtone excitation, to prepare highly vibrationally excited initial states, and time-resolved spectroscopic detection, to probe the evolution of the prepared state, for studying energy transfer in vibrationally energized molecules. Our experiments on acetylene have demonstrated the power of this approach for learning about otherwise inaccessible vibrations in electronically excited molecules, for determining the pathways of intramolecular energy transfer in isolated molecules, and for measuring fully state resolved rotational and vibrational energy transfer rates in collisions.			
14. SUBJECT TERMS		15. NUMBER OF PAGES 27	16. PRICE CODE
17. SECURITY CLASSIFICATION OF REPORT UNCLASSIFIED	18. SECURITY CLASSIFICATION OF THIS PAGE UNCLASSIFIED	19. SECURITY CLASSIFICATION OF ABSTRACT UNCLASSIFIED	20. LIMITATION OF ABSTRACT

COMPLETED PROJECT SUMMARY

TITLE: *Energy Transfer Dynamics in Isolated and Colliding Highly vibrationally Excited Molecules*

PRINCIPAL INVESTIGATOR: F. Fleming Crim

INCLUSIVE DATES: November 1, 1991 - October 31, 1994

GRANT NO.: F49620-92-J-0040

SENIOR RESEARCH PERSONNEL: Dr. M. B. Randunsky
Dr. Jon A. Booze

JUNIOR RESEARCH PERSONNEL: D. B. Govoni
M. D. Fritz
M. J. Coffey

PUBLICATIONS:

Energy Transfer in Highly Vibrationally Excited Acetylene: Relaxation for Vibrational Energies from 6,500 to 13,000 cm^{-1} . A. L. Utz, J. D. Tobiason, E. Carrasquillo M., M. D. Fritz, and F. F. Crim, *J. Chem. Phys.* **97**, 389 (1992).

State-to-State Rotational Energy Transfer in Highly Vibrationally Excited Acetylene. J. D. Tobiason, A. L. Utz, and F. F. Crim, *J. Chem. Phys.* **97**, 7437 (1992).

The Direct Observation, Assignment, and Partial Deperturbation of the ν_4 and ν_6 Vibrational Fundamentals in $1A_u$ Acetylene (C_2H_2), A. L. Utz, J. D. Tobiason, E. Carrasquillo M., L. J. Sanders, and F. F. Crim, *J. Chem. Phys.* **98**, 2742 (1993).

The Direct Observation, Assignment, and Partial Deperturbation of ν_5 and $\nu_3+\nu_5$ in $1A_u$ Acetylene (C_2H_2), J. D. Tobiason, A. L. Utz, and F. F. Crim, *J. Chem. Phys.* **99**, 928 (1993).

Direct Measurements of State-To-State Rotational and Vibrational Energy Transfer in Highly Vibrationally Excited Acetylene: Vibrational Overtone Excitation-LIF Detection. J. D. Tobiason, A. L. Utz, and F. F. Crim, *Proceedings SPIE Conference on Laser Techniques for State-Selected and State-to-State Chemistry, SPIE Proceedings*, **1858**, 317 (1993).

Normal Modes Analysis of A-state Acetylene Based on Directly Observed Fundamental Vibrations, J. D. Tobiason, A. L. Utz, E. L. Sibert, and F. F. Crim, *J. Chem. Phys.* **99**, 5762 (1993).

Direct Measurements of Rotation Specific, State-to-state Vibrational Energy Transfer in Highly Vibrationally Excited Acetylene, J. D. Tobiason, A. L. Utz, and F. F. Crim, *J. Chem. Phys.* **101**, 1108 (1994).

Direct Observation of Weak State Mixing in Highly Vibrationally Excited Acetylene. A. L. Utz, E. Carrasquillo M., J. D. Tobiason, and F. F. Crim, *Chem. Phys.* **190**, 311 (1995).

State-to-state Relaxation of Highly Vibrationally Excited Acetylene by Argon. J. D. Tobiason, M. D. Fritz, and F. F. Crim, *J. Chem. Phys.* **101**, 9642 (1994).

ABSTRACT OF OBJECTIVES AND ACCOMPLISHMENTS:

The flow of energy in molecules, either isolated or colliding, is fundamental to complex phenomena occurring in atmospheric chemistry, combustion, molecular lasers, plasmas, and a host of other environments containing energetic species. We have developed, proven, and applied a technique that combines vibrational overtone excitation, to prepare highly vibrationally excited initial states, and time-resolved spectroscopic detection, to probe the evolution of the prepared state, for studying energy transfer in vibrationally energized molecules. Our experiments on acetylene have demonstrated the power of this approach for learning about otherwise inaccessible vibrations in electronically excited molecules, for determining the pathways of intramolecular energy transfer in isolated molecules, and for measuring fully state resolved rotational and vibrational energy transfer rates in collisions.

Accession For	
NTIS CRA&I	<input checked="" type="checkbox"/>
DTIC TAB	<input type="checkbox"/>
Unannounced	<input type="checkbox"/>
Justification	
By	
Distribution /	
Availability Codes	
Dist	Avail and/or Special
A-1	

INTRODUCTION

Vibrationally excited molecules play crucial roles in a large assortment of physical and chemical processes, particularly ones that consume or release substantial amounts of energy. Understanding the nature of highly vibrationally excited molecules and energy flow among their internal degrees-of-freedom, both in isolation and in collisions, is essential to unraveling the complex physical and chemical processes involved in combustion, in atmospheric chemistry, in the operation of molecular lasers, and in many other processes in which highly energized molecules participate. Examples range from chemical lasers and combustion to surface etching with reactive species generated from highly vibrationally excited precursors. State-resolved studies of energy redistribution in highly vibrationally excited molecules are also a means of critically testing theoretical descriptions of intramolecular dynamics and of the interaction of an excited molecule with a collision partner.

Preparation and characterization of the initially excited state is the first step in state-resolved studies of energy flow in highly vibrationally excited molecules.^{1,2} The technique we have used, vibrational overtone excitation, is one means of preparing a single eigenstate in a molecule with 100 to 200 kJ/mol of vibrational energy.¹ Such a stationary state will not evolve in time, but it does carry information about the time evolution that would ensue for different preparation schemes.³ Because the spectroscopy of the molecule reflects the interaction among the vibrations in the molecule, a measurement that probes the eigenstate structure can reveal the intramolecular energy transfer dynamics. Collisions redistribute energy as well. Following the preparation of an eigenstate of a highly vibrationally excited molecule, a collision can move energy among its degrees-of-freedom with an efficiency that depends on the nature of the initially excited state, the forces operative during the collision, and the structure of the collision partner. State-resolved vibrational overtone excitation experiments are a means of exploring collisional energy transfer in highly vibrationally excited molecules by preparing a molecular eigenstate and spectroscopically probing either the initially prepared state or those states populated by subsequent collisions. The experiments described in this proposal provide new data on energy flow in both isolated and colliding highly vibrationally excited

molecules. Our goal is to characterize highly vibrationally excited molecules at the level of individual quantum states and to determine the pathways and mechanisms of energy redistribution in these energetic species.

Direct excitation of overtone vibrations is an excellent means of preparing highly vibrationally excited molecules for energy transfer experiments. Exploiting the preparation and interrogation steps in our experiments to learn about relaxation in highly energized molecules requires a detailed understanding of the states we prepare, and one of our goals is the characterization of these states. The local mode model of stretching vibrations involving light atoms describes the coarse features observed in vibrational overtone spectroscopy quite well,⁴ but a complete description of the molecular eigenstates that can be prepared in small molecules requires an extension of the model to include other vibrational motions. A very useful picture,⁵ which is similar to theories of radiationless transitions,⁶ treats an anharmonic, high-frequency vibration, such as a C-H, N-H, or O-H stretch, as the "bright" zero-order state that carries the vibrational overtone transition strength and couples that to the other "dark" zero-order states in the molecule. The coupling between the background states $\{|\ell\rangle\}$ and the bright zero-order state $|s\rangle$ produces the molecular eigenstates $\{|n\rangle\}$, each of which is a mixture of the interacting zero-order states, $|n\rangle = C_s^n |s\rangle + \sum C_\ell^n |\ell\rangle$. The strength of the transitions in a spectrum depends on the amount of the character of the bright state, as determined by C_s^n , that each eigenstate possesses. The value of this model is its description of the eigenstates in terms of zero-order states about which one has good chemical intuition. This is particularly useful in thinking about the vibrational overtone excitation probability as arising from the local mode vibration of a bond to a light atom and, as discussed below, in modelling electronic excitations from vibrationally excited states using Franck-Condon factors based on the zero-order states. Of course, knowing the complete set of coefficients and eigenstate energies allows one to predict the time-evolution of the local mode zero-order state, if it were to be prepared.^{3,7} Our nanosecond-duration laser pulses prepare an eigenstate that is a linear combination of zero-order states, and the probe step selects out certain zero-order states $|\ell\rangle$ that have large Franck-Condon factors in the electronic excitation.

Fully state-resolved studies of energy transfer in highly vibrationally excited molecules require the preparation, characterization, and time-resolved observation of the energized species. Over the last several years, we have developed schemes for characterizing states prepared by vibrational overtone excitation and for monitoring the evolution of the population of states in highly vibrationally excited molecules during collisional energy transfer. Because our detection schemes involve electronically excited states, we have also uncovered new features of electronically excited states. Our techniques have permitted a detailed analysis of the vibrational state structure,^{8,9} collisional energy transfer,¹⁰⁻¹⁴ and electronic state spectroscopy¹⁵⁻¹⁷ in acetylene, the prototypical molecule for our studies.

Isolated Molecules

The spectroscopic signatures of the interactions that control intramolecular energy flow are the energy and intensity of transitions to the eigenstates. When one type of interaction dominates the intramolecular dynamics, the resulting perturbation is obvious and dramatic, as in the creation of a pair of transitions by a Fermi resonance between two vibrations where there would be only one in the absence of the interaction.¹⁸ Such anharmonic interactions can become numerous and complicated in even moderate size polyatomic molecules, but it is possible to analyze spectra to identify the most important interactions and infer the intramolecular dynamics that would follow preparation of a nonstationary state. The spectra often require some experimental simplification to be tractable. For example, one may reduce the complexity of an absorption spectrum by cooling the molecules in a supersonic expansion or by using double resonance excitation to select only one angular momentum state or by employing a detection technique that is sensitive to states of a particular type. We have used all of these approaches to study different highly vibrationally excited molecules and, in particular, have exploited selective detection in a study of highly vibrationally excited acetylene as part of our AFOSR sponsored research.⁸⁻¹⁷

Polyatomic molecules can have extensive interactions among their vibrations even with relatively small amounts of internal energy, particularly in molecules with densities of states that are

large enough to place several interacting states near to each other. Infrared absorption spectra in the region of the C-H stretching fundamental of several alkynes illustrate both the technique of simplifying absorption spectra by cooling molecules in a supersonic expansion and the rich spectroscopy of polyatomic molecules with several interacting vibrations.¹⁹⁻²¹ Resolved infrared fluorescence measurements by McDonald and coworkers²² provide similar insights using both cooling of molecules and a detection technique that is sensitive to particular vibrations. The infrared fluorescence spectra of molecules prepared in a selected state reveal the extent of interaction of the vibration that carries the excitation probability with others in the molecule. Experimental studies of the intramolecular dynamics of highly vibrationally excited molecules can exploit a similar combination of state preparation and selective detection for simplifying spectra. For example, double resonance approaches have provided a new window on the behavior of highly vibrationally excited molecules. Stimulated emission pumping (SEP), a folded double resonance scheme,²³ has furnished unique data on highly vibrationally excited formaldehyde,²⁴ acetylene,²⁵ HCP,²⁶ and HCN,²⁷ that allow one to infer intramolecular dynamics from spectral structure. Models containing only a few strongly interacting vibrations, such as a Fermi resonance coupled C-H stretching vibration and CCH bending vibration, often reproduce many features of vibrational overtone absorption spectra and provide the information to predict the time evolution of the energy in an initially excited C-H stretching vibration.²⁸⁻³² One of the important themes in analyzing the spectra of these highly vibrationally excited molecules is the connection between the spectroscopy, the state coupling, and the predicted time evolution.³

Colliding Molecules

Additional forces, beyond those in an isolated molecule, act during collisional energy transfer. In this case, the nature of the collision partner and its energy level structure as well as the intramolecular couplings and energy levels of the initially excited molecule influence the pathway and efficiency of energy redistribution. Most of the data on collisional energy transfer in highly vibrationally excited molecules come from chemical activation studies in which the competition between unimolecular reaction and collisional quenching of an energized molecule created by an exothermic chemical reaction reveals the relaxation rate of the reacting species.³³ Although this technique is not particularly selective, it has provided much of the data that form the basis for current models of the collisional dynamics of highly vibrationally excited molecules. The excitation scheme that has provided the greatest body of new detailed data on highly vibrationally excited molecules is electronic excitation followed by rapid internal conversion to populate high vibrational levels of the ground electronic state of a molecule.³⁴ This technique, which adds a precisely known energy to molecules in a thermal distribution of internal states, has produced a great deal of data on large polyatomic molecules and even triatomic species.³⁵

The most detailed and complete comparison to theory requires state resolved experiments that determine relaxation rates and pathways from specified quantum states. Experiments using single photon infrared excitation,³⁶ Raman excitation,³⁷ or stimulated emission pumping³⁸ along with laser induced fluorescence detection have produced data at that level of detail for collisional relaxation in polyatomic molecules with small ($\epsilon_{\text{vib}} < 3000 \text{ cm}^{-1}$) vibrational energy content. We use laser excitation of an overtone vibration to prepare the excited species and time-resolved laser induced fluorescence to probe the molecules during collisional relaxation. Our studies of rotational and vibrational relaxation in acetylene are one of a few examples of a state-to-state measurement of collisional relaxation in a highly vibrationally excited polyatomic molecule ($\epsilon_{\text{vib}} \approx 6500 - 13,000 \text{ cm}^{-1}$),¹⁰⁻¹⁴ and there is a recent application of the same approach to HCN.³⁹ Another important example of a state resolved collisional energy transfer measurement is work on formaldehyde

(H₂CO) by Temps, *et al.* using stimulated emission pumping in combination with time-resolved ultraviolet laser absorption.⁴⁰ Because the two excitation techniques prepare rather different initial states in similar energy regimes, they are very complementary, and, as discussed below, we believe that vibrational overtone excitation and stimulated emission pumping studies on the same molecules may be quite informative. The development and use of vibrational overtone excitation and state resolved detection to study energy transfer is the important accomplishment during our current period of Air Force Office of Scientific Research support. We have also laid the groundwork for extending this approach to more complicated molecules using double resonance vibrational overtone excitation.

RECENT RESULTS

Our recent work illustrates all three aspects of the combination of laser preparation of a rovibrational eigenstate and laser induced fluorescence probing of the vibrationally excited molecule: identification and characterization of the initially excited vibrational state,⁸ determination of the state-to-state relaxation pathways and rates of the vibrationally excited molecules,¹⁰⁻¹⁴ and characterization of the excited electronic state in the probe step.¹⁵⁻¹⁷ The *spectroscopy of the initially excited state* reveals the couplings responsible for intramolecular energy transfer, and, as describe below, our detection scheme is a way to observe eigenstate structure that is invisible in most conventional absorption experiments. Monitoring the evolution of the initially excited state and the transfer of population into different states during *collisional relaxation* provides the rotational and vibrational relaxation rates for single eigenstates in highly vibrationally excited molecules. Laser induced fluorescence excitation spectra from single initially selected vibrational states provide previously unavailable information on vibrations in the *electronically excited state* since the probe laser directly accesses states that have no one-photon transition from the ground state. This section outlines our recent AFOSR sponsored research that characterizes vibrationally excited molecules, studies their energy transfer dynamics, and explores the electronically excited states we excite. It also briefly

describes the construction of an optical parametric oscillator for new double resonance vibrational overtone excitation experiments.

Our approach prepares an initial state by exciting a vibrational overtone transition with a pulsed laser and interrogates the highly vibrationally excited molecule, either immediately after excitation or after a time delay, with a second, ultraviolet laser. The excitation transition reaches a high vibrational level in the ground electronic state, and the probe transition is to an electronically excited state from which we observe fluorescence. The state prepared in the first step of our recent experiments is an eigenstate. By characterizing this state, we learn about the couplings in the molecule and, hence, its intramolecular dynamics. By allowing the molecule in this state to have a collision and monitoring the change in its population or the population of the state to which it transfers energy, we are able to discover the pathways of collisional relaxation.

Figure 1 is an energy level diagram that illustrates the excitation and detection scheme for the particular case of highly vibrationally excited acetylene probed by laser induced fluorescence. Varying the wavelength λ_2 of the probe laser generates the laser induced fluorescence excitation spectrum of the highly vibrationally excited molecule, and, by selecting wavelengths corresponding either to initially prepared or collisionally populated states, we can monitor their time evolution. For example, the Figure shows the situation in which collisional energy transfer removes molecules from the initially populated state with bimolecular rate constant k . This collisional depopulation appears as a decrease in the LIF signal for longer intervals between the pulse from the vibrational overtone excitation laser (λ_1) and that from the probe laser (λ_2).

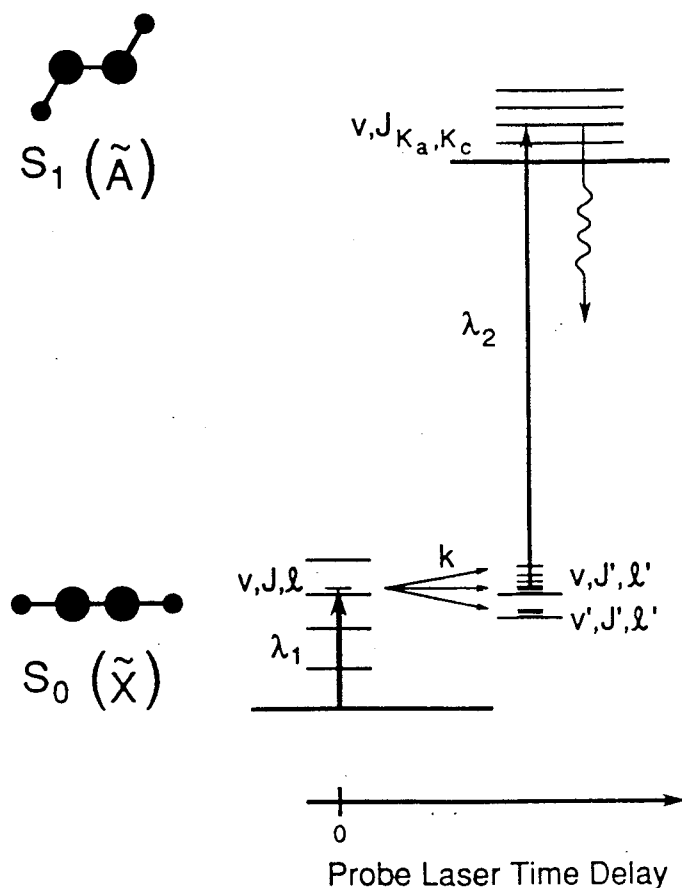

Figure 1

Spectroscopy of the Initially Excited State

The intensity of a transition in the laser induced fluorescence excitation spectrum depends on the Franck-Condon overlap integral between the highly vibrationally excited, ground electronic state and the particular rovibrational level of the excited electronic state to which we tune the probe laser. One of the keys to our measurements, in which the vibrational overtone transition excites fewer than 10^{-5} of the molecules, is efficient discrimination against vibrationally unexcited species. As Figure 1 illustrates, we use probe laser photons that have only enough energy to reach the few lowest levels of

the electronically excited state in transitions from highly vibrationally excited molecules. Because these photons are unable to excite molecules from low vibrational levels of the ground state, our detection scheme favors "off-diagonal" probe transitions in which a large geometry change produces good Franck-Condon factors between the vibrationally excited molecule in the ground electronic state and the vibrationally unexcited molecule in the excited electronic state. The Franck-Condon factors for off-diagonal transitions of vibrations involving light atoms are often small, since the bond lengths change little upon electronic excitation, but those for lower frequency vibrations can be larger. The amount of the bright zero-order state $|s\rangle$ in an eigenstate determines its vibrational overtone excitation probability, but, in the systems we study, the amount of a dark zero-order state $|t\rangle$ controls the intensity of its transitions in the probe step. *This situation provides an experimental window on the nature of the initially prepared state.* The intensity in the probe spectrum reflects the extent to which the eigenstate resembles the zero-order states that have favorable Franck-Condon factors in the electronic transition.

Figure 2

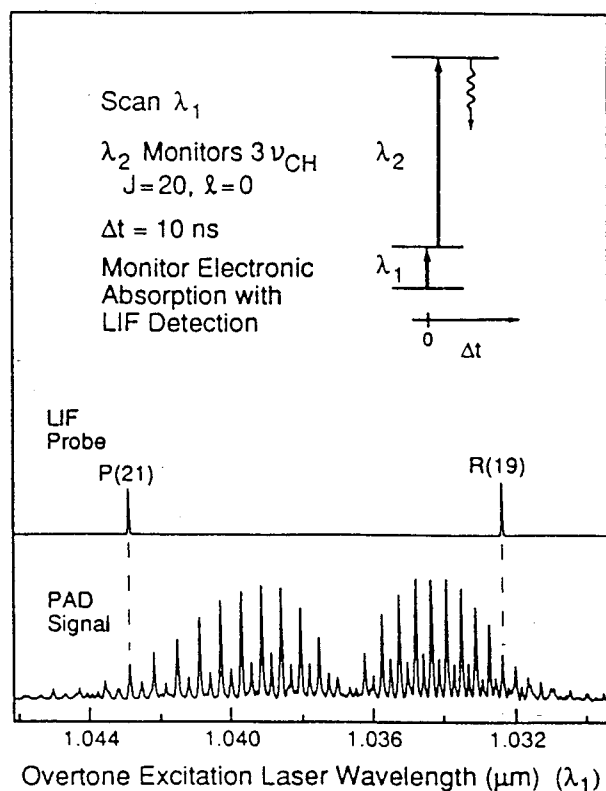

A simple measurement on acetylene illustrates the means by which we probe highly vibrationally excited states.^{8,9} The lower portion of Figure 2 is the photoacoustic absorption spectrum for acetylene showing transitions to single rotational states in the region of the second overtone of the C-H stretching vibration ($3\nu_{\text{CH}}$). (The spectrum also contains small contributions from other vibrational transitions. We can simulate the complete spectrum using known band centers and rotational constants for C_2H_2 .)⁴¹ The upper trace in the figure illustrates selective detection. In this case, the probe laser is tuned to an electronic transition that interrogates only those highly vibrationally excited molecules in $J=20$, which we can identify because we have analyzed the electronic spectroscopy as described below. The action spectrum obtained by scanning the vibrational overtone excitation wavelength shows only transitions that populate $J=20$ of the selected vibrational state since we are selectively interrogating that level. This is the key to the state resolution in our experiment. Having identified the electronic transitions for the highly vibrationally excited molecule, we can probe the populations of the rovibrational state we choose.

The transitions we excite in the probe step are between single rotational states in the highly vibrationally excited molecule and those in the electronically excited molecule. Because the ground electronic state ($X^1\Sigma_g^+$) of acetylene is linear and the excited electronic state (A^1A_u) that we access is *trans*-bent,⁴² the *trans*-bending vibration has particularly good off-diagonal Franck-Condon factors that lead to progressions in this vibration in resolved emission spectra.⁴³ Thus, we expect that zero-order states $| \ell \rangle$ with *trans*-bending excitation give the largest signal in the probe step, and we expect the states that we observe to have significant *trans*-bending character.

The selectivity of our detection scheme allows us to probe state mixing by observing eigenstates that have very little bright ($|s\rangle$) state character but a large component of dark ($| \ell \rangle$) state character. Transitions to these eigenstates are too weak to be observed in absorption, since they contain so little of the bright zero-order state, but they are prominent in our two-photon detection scheme, as Figure 3 illustrates. The upper panel (a) shows a portion of the photoacoustic vibrational overtone *absorption* spectrum in the region of the P(21) transition to the vibrational eigenstate that contains substantial bright state character. It is this large amount of bright state character that gives it

a strong absorption signal. The middle panel (b) is the laser induced fluorescence signal obtained by scanning the vibrational overtone excitation laser (λ_1) with the probe laser tuned to interrogate the same state as the absorption shown above. The lower panel (c) shows an LIF action spectrum *for which the probe laser is tuned to the $J=20$ rotational state of a different vibrational state that has mostly dark state character*. The transition to this mostly dark eigenstate occurs at a different wavelength than the transition to the mostly bright state that appears in the photoacoustic spectrum. The energy level diagram on the right of the figure illustrates the situation schematically. In absorption we see only one of the mixed pair of states, but in the LIF action spectrum, which is sensitive to dark state character, we can see both. (We are confident of the assignments because we have independently characterized the electronic spectroscopy, and we obtain equivalent results using the R(19) transition to reach the same, $J=20$, vibrationally excited state.) The locations of the probe transitions for the mostly dark eigenstates come from a two-dimensional search, a procedure that we have recently automated by scanning both lasers simultaneously to keep the total energy constant.⁴⁴

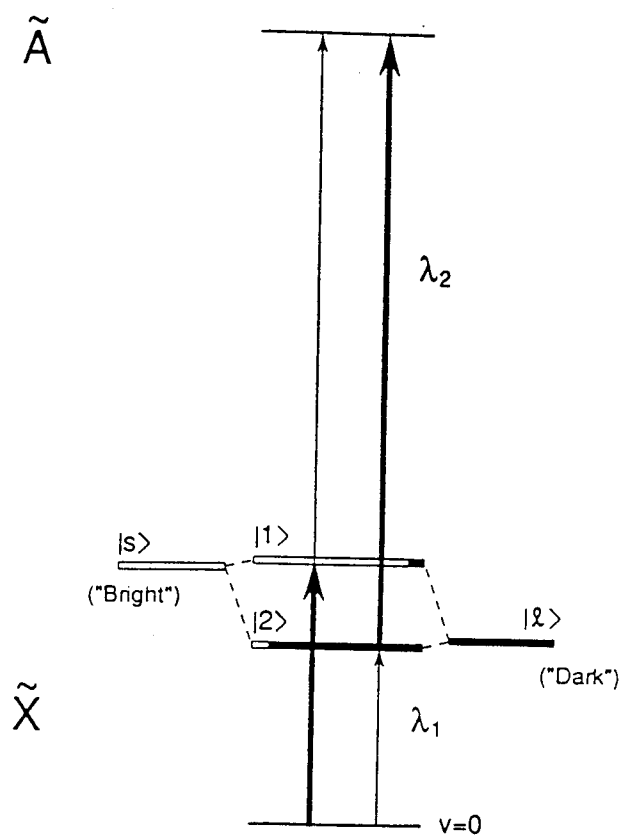
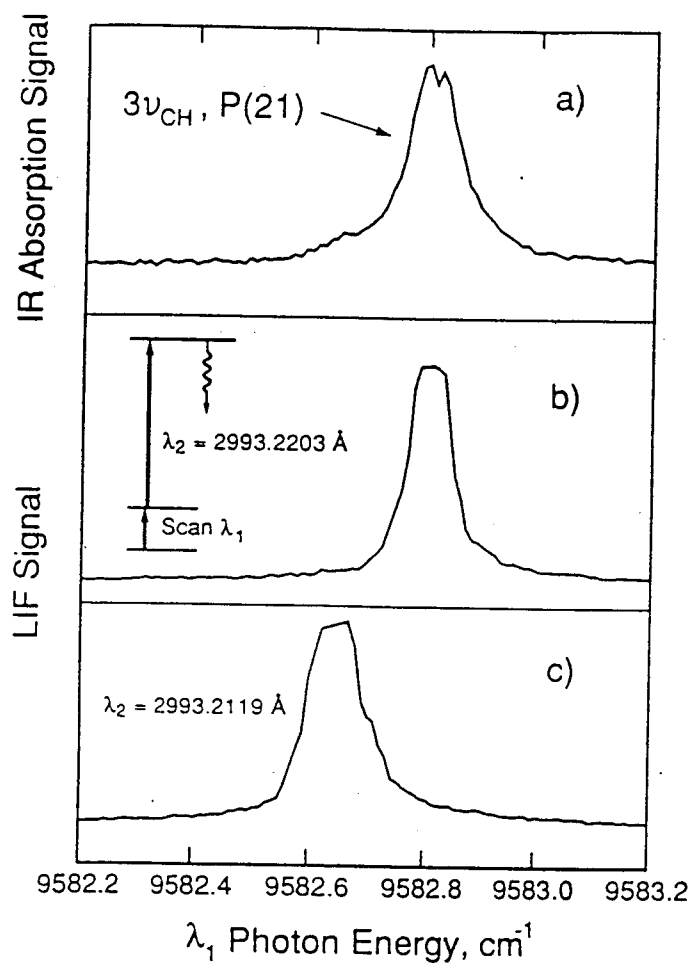

Figure 3

The separation between the mostly bright and mostly dark eigenstates depends on the rotational state since they have different rotational constants. Table I summarizes the rotational constants and vibrational frequencies we extract for three of the dark zero-order states by a deperturbation analysis.^{8,9} The mostly dark eigenstates we observe have far too little transition strength (bright state character) to be observed in absorption. In fact, we find that we are able to observe states⁴⁴ that even ultrasensitive absorption techniques⁴⁵ do not see. The rotational constants for the mostly dark zero-order states are consistently larger than for the bright zero-order state, reflecting substantial of *trans*-bending excitation, which lowers the moment of inertia, in the dark state. This is consistent with dark state containing large amounts of *trans*-bending excitation having good Franck-Condon factors for the probe transition to the bent, electronically excited $A\sim$ state. The deperturbation analysis gives the coupling matrix elements between the bright and dark states listed in Table I. These are typical of those found among vibrational states^{48,47} and are likely to come from anharmonic interaction of the states. Combining the deperturbation analysis that gives the results in the table with a careful enumeration of the states in acetylene allows us to identify the dark states. The two candidates are the $(0,1,0,11^{t4},1^{t5})$ and $(1,0,0,9^{t4},1^{t5})$ states. The first has one quantum of C=C stretch, 11 quanta of *trans*-bend, and one of *cis*-bend excitation. The second has one quantum of symmetric C-H stretching excitation along with nine of *trans*-bend and one of *cis*-bend excitation. They also contain significant vibrational angular momentum, with values as large as $\ell_4=7$, which is consistent with our observing transitions to electronically excited states with large values of the K quantum number.

Table I: Energies and rotational constants of the bright and dark zero order states

Zero-order State	Energy (cm ⁻¹)	Rotational Constant, B _v (cm ⁻¹)	Coupling Matrix Element (cm ⁻¹)
3v _{CH} ⟩	9639.8536	1.158356	
a⟩	9634.3(2)	1.1757(6)	0.015(4)
b⟩	9631.8(2)	1.1772(3)	0.030(3)
c⟩	9631.2(2)	1.1744(5)	0.049(3)

Collisional Energy Transfer

The range of states we can excite and interrogate has allowed us to perform a hierarchy of collisional energy transfer measurements in which we have monitored total relaxation,^{10,11} state-to-state rotational energy transfer,¹² and state-to-state vibrational energy transfer^{13,14} in collisions of highly vibrationally excited acetylene molecules with ground state molecules and with Ar atoms.⁴⁹ In these experiments, we observe collisional energy transfer from single quantum states of highly vibrationally excited molecules by fixing the vibrational overtone excitation wavelength on a particular rotational transition and selecting a probe laser wavelength that induces fluorescence from the initially populated state. Varying the delay between the two lasers reveals the time-evolution of the initially prepared state. We can tune the probe laser to monitor a collisionally populated state and observe the growth in population of that final state as well. Thus, we have the means of determining

state resolved rates and collisional relaxation pathways in molecules containing over 100 kJ mol⁻¹ of vibrational energy, as our measurements on acetylene demonstrate.¹⁰⁻¹⁴

Total Relaxation¹¹

The simplest measurement is to tune the probe laser to the initially excited state and monitor the decrease in laser induced fluorescence intensity as collisions remove molecules from the initially excited state. Figure 4(a) shows typical data for a relatively high pressure measurement (0.500 Torr), and Figure 4(b) shows them at a low pressure (0.025 Torr). In the latter case, fewer than 10% of the molecules have a collision during the 150-ns delay between the lasers. Our ability to obtain good data under these single collision conditions is important in the state-to-state measurements described below.

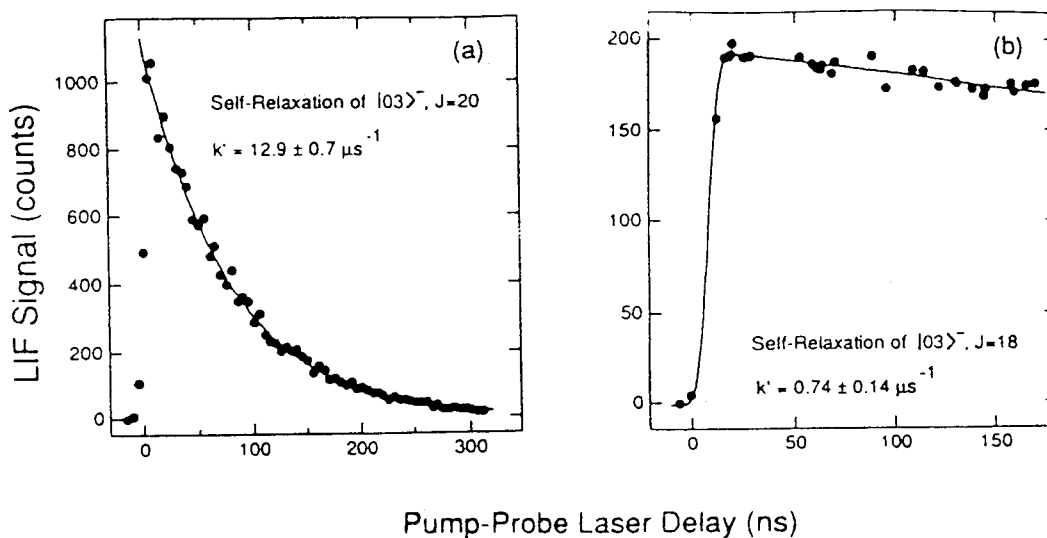

Figure 4

The total relaxation rates that we measure for the first ($2\nu_{\text{CH}}$), second ($3\nu_{\text{CH}}$), and third ($4\nu_{\text{CH}}$) C-H stretching overtone vibrations, whose energies range from 6500 to 13,000 cm⁻¹, are all the same within the uncertainty of the measurement. The rate constant of about $9 \times 10^{-10} \text{ cm}^3 \text{ molecule}^{-1} \text{ s}^{-1}$ is about twice the Lennard-Jones collision rate constant and corresponds to an average energy transfer cross section of 120 \AA^2 . Figure 5(b) shows the rate constants for these states along with the results of pressure broadening measurements,⁵⁰ which give the same total rate as our direct population transfer measurements. As Figure 5(a) shows, the relaxation rate constant decreases slightly with increasing

initial rotation, in agreement with the pressure broadening data for the same state ($2\nu_{\text{CH}}$). (This is the only state where there are both population transfer and pressure broadening data.) The magnitude of the cross section, its constancy with vibrational level, and its decrease with increasing rotational level all hint at the relaxation occurring mostly by rotational energy transfer. The test of this inference is a direct measurement of the fate of the excited molecules during the relaxation.

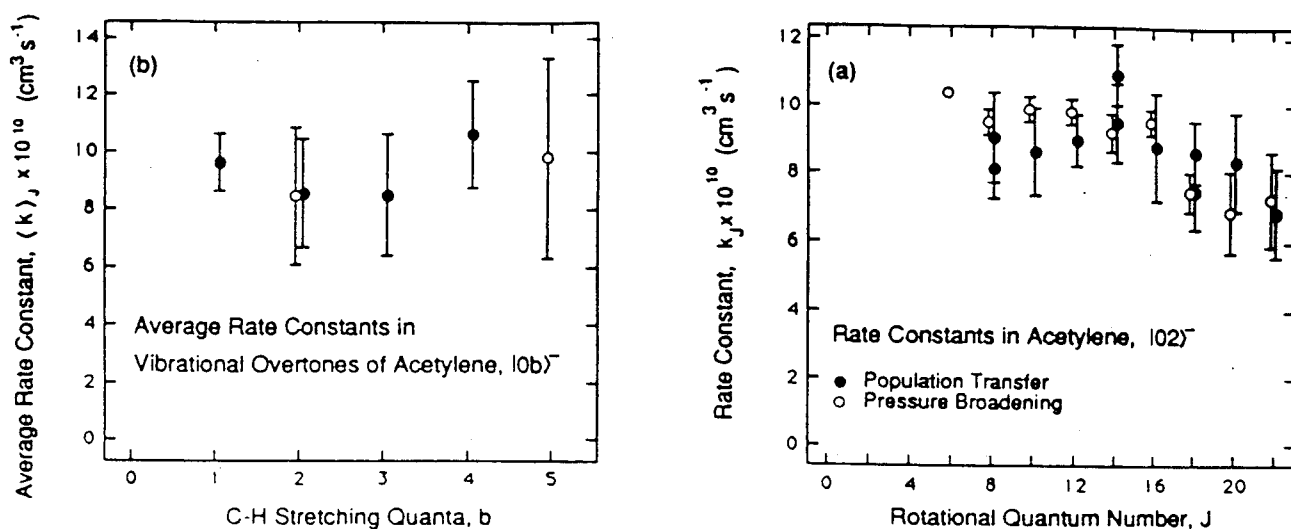

Figure 5

*State-to-State Rotational Energy Transfer*¹²

The relatively small energy separation between adjacent rotational levels, even in a light molecule like acetylene, makes a number of energy transfer pathways available out of any single initial state. To extract *state-to-state* rotational energy transfer rates without an involved and, usually, model dependent kinetic analysis, we work under single collision conditions, where the increase in signal from a particular destination state reflects the arrival of population in that state *directly* from the initial state, without the complication of transfer through other rotational states in multiple collisions.⁵¹ We observe state-to-state rotational energy transfer by fixing the interrogating laser on a

particular destination state and scanning the vibrational overtone excitation laser through different initial rotational states, as the left hand side of Figure 6 illustrates. This avoids an involved calibration of probe laser sensitivity since all the transfer is into the same final state, and it produces an excitation spectrum that shows the pathways and relative rates of rotational energy transfer at a glance. The right hand side of Figure 6 shows the spectrum obtained by fixing the probe laser on $J=20$ of $3\nu_{CH}$ and scanning the vibrational overtone excitation laser through different rotational states. The bottom trace (c) is the photoacoustic spectrum showing the location of all of the rotational transitions to $3\nu_{CH}$ of acetylene. The middle trace (b) is the spectrum under single collision conditions and the top trace (a) shows the spectrum when there are essentially no collisions during the time between the vibrational overtone excitation laser pulse and that from the probe laser.

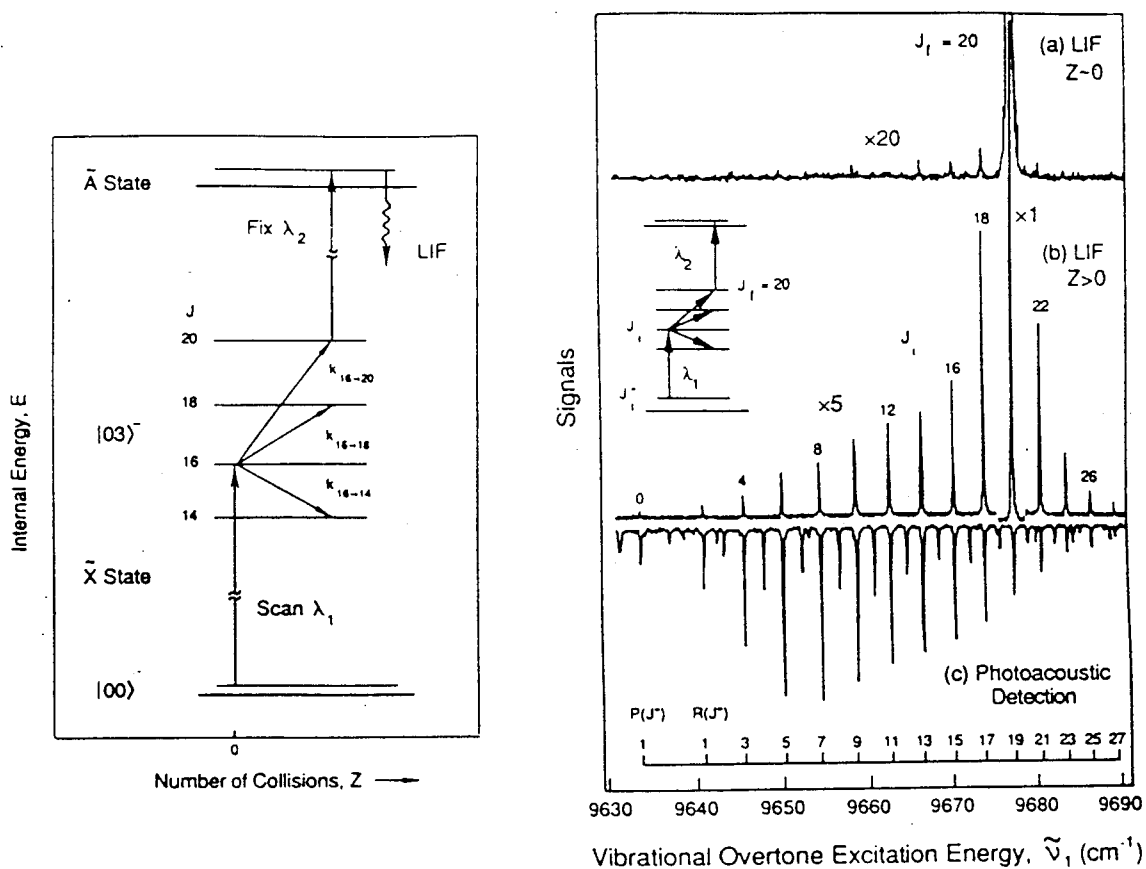

Figure 6

The intensities in the photoacoustic spectrum reflect the thermal population and absorption strength of the different initial rotational states. Those in the action spectrum (b) reflect both of those factors *as well as the rate of collisional transfer out of the different initial states into the final state* (in this case $J=20$). The action spectrum immediately shows two features of the rotational energy transfer in acetylene. One is that *collisions produce only even changes in the rotational quantum number*. The action spectrum contains only transitions from even rotational states into $J=20$, as required by conservation of nuclear spin. The second is that *the transitions extend over a broad range of angular momentum states*. The presence of the P(1) transition, corresponding to transfer from $J=0$ to $J=20$, shows that a single collision occasionally changes the rotational angular momentum by $20\hbar$. Using this approach we extract quantitative values of the state-to-state rotational energy transfer rate constants for a range of initial and final states.¹² The resulting set of 50 rate constants permit some detailed comparisons. In particular, the largest state-to-state rate is one-third of the Lennard-Jones collision rate. Using detailed balance, we can obtain a complete set of rate constants for state-to-state transfer from a particular initial state into all final states. Summing these rate constants for rotational energy transfer and comparing them to our measured total relaxation rate constant,¹¹ shows that rotational relaxation accounts for 70% of the total relaxation of an initial

state. Thus, we infer that rapid, collision induced intramolecular vibrational energy transfer accounts for the rest. Monitoring different final *vibrational* states allows us to test this conclusion as well.

State-to-State Vibrational Energy Transfer^{13,14}

Monitoring a single rotational state in a *different final vibrational state* under single collision conditions gives the fully state-resolved vibrational energy transfer rate constant. The approach, shown in Figure 7, is identical to the rotational energy transfer measurements *except* we fix our probe

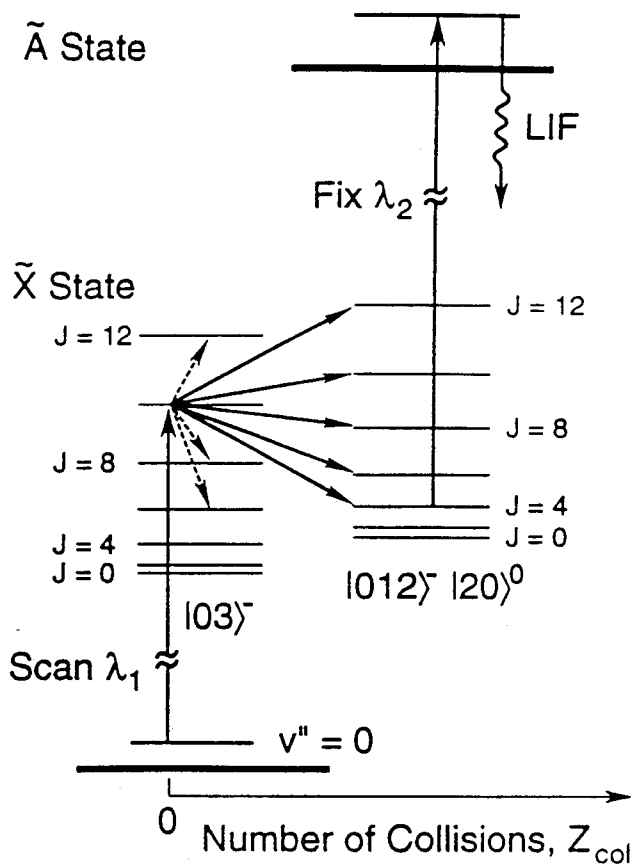

Figure 7

laser on a rotational state ($J_f=4$) in the $|012\rangle\text{-}|20\rangle^0$ vibrational state and scan our excitation laser through the different rotational states of the $|03\rangle^-$ state. (The final vibrational state has two quanta of C-H stretch, one of C=C excitation, and two of *trans*-bending while the latter has three quanta of C-H stretching excitation. In normal mode notation the final and initial states are (111200) and (00100) respectively.) For a *single* rotational level, the vibrational energy transfer occurs in about 160 collisions. The total transfer, obtained by summing the rates into all of the final states, has a rate constant of $1.3 \mu\text{s}^{-1}\text{Torr}^{-1}$, corresponding to only 13 collisions. This very fast relaxation appears to reflect a Fermi resonance that couples the two vibrational levels. Because we obtain the vibrational energy transfer rate for each rotational state, we also uncover a few states that relax even faster. Transfer from $J_i=16$ and $J_i=20$ is particularly efficient, probably because of particularly strong intramolecular couplings that mix the initial state with other vibrations, which themselves promote vibrational energy transfer. Our spectroscopic studies point to these special couplings for $J=16$ and 20, and the energy transfer measurements find them as well.

Vibrations in the Electronically Excited State

The involvement of an electronically excited state in our detection scheme creates both a complication and an opportunity. In some cases, we must sort out new electronic spectroscopy to completely analyze our measurements, but we have an opportunity to observe vibrations in the electronically excited state that are often inaccessible. Two features of our experiment make this possible. One is that the excitation in the probe step (see Figure 1) comes from states in a molecule that contain far more vibrational energy than available in a room-temperature sample. Thus, transitions that appear only as very weak hot-bands in a conventional experiment might be quite strong in our measurement. The other differentiating feature is that we reach the electronic state by a two-photon process, one for vibrational overtone excitation and one for the subsequent electronic excitation. In molecules of high symmetry, this makes available a set of vibrations of the excited state that are unobservable in the one-photon electronic excitation. Because the first transition is solely on the ground electronic surface, we can easily perform two-photon measurements on the

lowest electronically excited state. The excitation goes through a real state of known vibrational symmetry and, hence, reaches a limited subset of the available vibrations in the excited state. For example, our two-photon excitation scheme reaches the *ungerade* vibrational states in acetylene, which have not been observed previously by direct excitation.

The first excitation from the vibrationally unexcited molecule prepares a vibration of b_u symmetry in the A_g ground electronic state. (The symmetry of the ground Σ_g^+ electronic state is A_g in the reduced symmetry of the C_{2h} point group of the bent electronically excited state.) In the absence of collisions, the second transition reaches a *ungerade* vibration in the A_u electronically excited state, compared to one-photon transitions that can excite only *gerade* vibrations. In the absence of Coriolis coupling, which can mix vibrations of a and b symmetry, the second photon excites only b_u vibrations (the antisymmetric C-H stretch ν_5 and the *cis* bend ν_6), but Coriolis coupling can mix the states to permit transitions to the a_u vibration (the out-of-plane torsion ν_4). Our approach allows us to unravel the complicated spectrum and directly observe these three vibrations for the first time.^{15,16} This not only provides new information on the electronically excited state but is also the basis of our vibrational analysis in the state mixing experiments. Exploiting the J selection of our double resonance experiment, we have analyzed the spectra to obtain vibrational frequencies of $\nu_4=764.9$, $\nu_5=2857.4$, and $\nu_6=768.3$ cm^{-1} for the *ungerade* vibrations. We obtain rotational constants and, through the Coriolis coupling analysis, coupling constants for the electronically excited state. The antisymmetric C-H stretching vibration ν_5 has never been observed, and our measured frequency¹⁶ is about 400 cm^{-1} smaller than the *ab initio* prediction. The values^{15,16} for ν_4 and ν_6 differ by about 80 cm^{-1} from assignments based on a two-quantum deperturbation analysis in resolved laser induced emission experiments.⁴³ Direct observation of these states is an important ancillary benefit of using laser induced fluorescence to probe highly vibrationally excited molecules. Combining these measurements with those on other isotopes has also allowed us to perform a complete normal modes analysis that produces a set of force constants and predicted frequencies for all the vibrations in the A_u state.¹⁷ The analysis confirms the tentative assignments of several other workers and suggests revision of some others. In particular, our best estimate of the frequency of the

symmetric C-H stretching vibration indicates that it should be lowered by about 100 cm^{-1} to 2954 cm^{-1} . Our detection scheme, which requires extensive information about the electronically excited state from independent spectroscopic studies, also adds to that body of knowledge.

Optical Parametric Oscillator

The key to many of our experiments is the ability to prepare a single rovibrational eigenstate of a vibrationally excited molecule and to interrogate it with quantum state resolution. Rotational congestion prevents our applying our vibrational overtone excitation scheme to molecules that are larger and less rigid than acetylene. We simply cannot excite one rotational state from a thermal sample. Reducing rotational congestion by cooling molecules in a supersonic expansion is a means of simplifying the vibrational overtone spectroscopy, as we have done with hydrogen peroxide, for example.⁵² This is incompatible with collisional energy transfer studies in low pressure gases and limits the spectroscopy to low rotational states. Because the rotational state affects both the spectroscopy and energy transfer dynamics, it is best to have a range of rotational states available, and projecting excited molecules out of a thermal distribution of rotational states has a big advantage. Double resonance vibrational overtone excitation, in which an infrared photon excites one or a few rotational states on a fundamental vibrational transition and another, near infrared or visible, photon excites the molecule to a higher vibrational state potentially overcomes the limitations of rotational state congestion. Rizzo and coworkers have demonstrated this approach in unimolecular decay and vibrational spectroscopy experiments on hydrogen peroxide, nitric acid, and hydroxylamine.⁴⁶

The principle construction goal during our current period of AFOSR funding is an optical parametric oscillator (OPO) for double resonance vibrational overtone excitation. We have completed the design and construction and begun testing our new device. It is designed to produce light in the range of 1.4μ to 4.0μ , and, in the first tests, it produced a pulse energy of over 12 mJ for the signal and idler beams together. We are in the midst of characterizing the OPO and planning our first experiments on double resonance collisional energy transfer. As discussed below, having

constructed and proven device, we are in a position to expand the scope of our vibrational energy transfer and spectroscopy experiments considerably.

REFERENCES

1. F. F. Crim, *Annu. Rev. Phys. Chem.* **35**, 657 (1984).
2. R. E. Weston and G. W. Flynn, *Annu. Rev. Phys. Chem.* **43**, 559-589 (1992).
3. M. Quack, *Annu. Rev. Phys. Chem.* **41**, 839 (1990).
4. B. Timm and R. Mecke. *Z. Phys.* **98**, 363 (1936); R. Mecke. *Z. Elektrochem.* **38**, 1950 (1950); B.R. Henry. *Acc. Chem. Res.* **10**, 207 (1977); *Vibrational Spectra and Structure*, ed. J.R. Durig. **10**, 269 (1981), New York: Elsevier; L. Halonen and M.S. Child. *Adv. Chem. Phys.* **57**, 1 (1984); M.S. Child. *Acc. Chem. Res.* **45**, 45 (1985).
5. P.R. Stannard and W.M. Gelbart, *J. Phys. Chem.* **85**, 3592 (1981); M.L. Sage and J. Jortner, *Adv. Chem. Phys.* **47**, 293 (1981); D.F. Heller and S. Mukamel, *J. Chem. Phys.* **70**, 463 (1979).; *Picosecond Phenomena*, ed. C.V. Shank, E.P. Ippen, and S.L. Shapiro. New York: Springer, 1978, p. 51.
6. P. Avouris, W.M. Gelbart, and M.A. El-Sayed. *Chem. Rev.* **77**, 793 (1977).
7. H.-R. Dübal and M. Quack. *J. Chem. Phys.* **81**, 3779 (1985); E.L. Sibert III, W.P. Reinhardt, and J.T. Hynes. *J. Chem. Phys.* **81**, 1115 (1984).
8. A. L. Utz, J. D. Tobiason, and F. F. Crim, *Chem. Phys.* (in preparation).
9. A. L. Utz, Ph.D. Thesis, University of Wisconsin, 1991.
10. E. Carrasquillo M., A.L. Utz, and F.F. Crim, *J. Chem. Phys.* **88**, 5976 (1988).
11. A. L. Utz, J. D. Tobiason, E. Carrasquillo M., M. D. Fritz, and F. F. Crim, *J. Chem. Phys.* **97**, 389 (1992).
12. J. D. Tobiason, A. L. Utz, and F. F. Crim, *J. Chem. Phys.* **97**, 7437 (1992).
13. J. D. Tobiason, A. L. Utz, and F. F. Crim, *Proceedings SPIE Conference on Laser Techniques for State-Selected and State-to-State Chemistry*, *SPIE Proceedings*, **1858**, 317 (1993).
14. J. D. Tobiason, A. L. Utz, and F. F. Crim, *J. Chem. Phys.* (1994) (in press).
15. A. L. Utz, J. D. Tobiason, E. Carrasquillo M., L. J. Sanders, and F. F. Crim, *J. Chem. Phys.* **98**, 2742 (1993).
16. J. D. Tobiason, A. L. Utz, and F. F. Crim, *J. Chem. Phys.* **99**, 928 (1993).
17. J. D. Tobiason, A. L. Utz, E. L. Sibert, and F. F. Crim, *J. Chem. Phys.* **99**, 5762 (1993).
18. G. Herzberg, *Molecular Spectra and Molecular Structure II. Infrared and Raman Spectra of Polyatomic Molecules*, Van Nostrand Reinhold Company, New York, 1945.
19. G. A. Bethardy and D. S. Perry, *J. Chem. Phys.* **98**, 6651 (1993); A. M. de Souza, D. Kaur and D. S. Perry, *J. Chem. Phys.* **88**, 4569 (1988); D. Kaur, D. S. Perry. and A. M. de Souza, *J. Chem. Phys.* **88**, 4569 (1988); J. S. Go, T. J. Cronin and D. S. Perry, *Chemical Physics* **175**, 127 (1993); J. Go and D. S. Perry, *J. Chem. Phys.* **97**, 6694 (1992).

20. A. McIlroy and D. J. Nesbitt, *J. Chem. Phys.* **91**, 104 (1989); A. McIlroy and D. J. Nesbitt, *J. Chem. Phys.* **92**, 2229 (1990)
21. J. E. Gambogi, K. K. Lehmann, B. H. Pate, G. Scoles and X. M. Yang, *J. Chem. Phys.* **98**, 1748 (1993); J. E. Gambogi, R. P. Lesperance, K. K. Lehmann, B. H. Pate and G. Scoles, *J. Chem. Phys.* **98**, 1116 (1993); E. R. T. Kerstel, K. K. Lehmann, T. F. Mentel, B. H. Pate and G. Scoles, *J. Phys. Chem.* **95**, 8282 (1991); K. K. Lehmann, B. H. Pate and G. Scoles, *Laser Chemistry* **11**, 237 (1991); K. K. Lehmann, B. H. Pate and G. Scoles, *J. Chem. Phys.* **93**, 2152 (1990); B. H. Pate, K. K. Lehmann and G. Scoles, *J. Chem. Phys.* **95**, 3891 (1991).
22. J.L. Kim, T.J. Kulp, and J.D. McDonald, *J. Chem. Phys.* **87**, 4376 (1987); T.K. Minton, H.L. Kim, and J.D. McDonald, *J. Chem. Phys.* **88**, 1539 (1988) and references cited.
23. C.E. Hamilton, J.L. Kinsey, and R.W. Field, *Annu. Rev. Phys. Chem.* **37**, 493 (1986).
24. C. L. Korpa, J. L. Kinsey, R. W. Field, and H. L. Dai, *J. Chem. Phys.* **82**, 1688 (1985); R. W. Field, J. W. Kinsey, H. L. Dai, and D. E. Reisner, *J. Chem. Phys.* **80**, 5968 (1984); P. H. Vaccaro, C. Kittrel, R. W. Field, J. L. Kinsey, H. L. Dai, and D. E. Reisner, *J. Chem. Phys.* **77**, 537 (1982).
25. D. M. Jonas, S. A. B. Solina, B. Rajaram, R. J. Silbey and R. W. Field, *J. Chem. Phys.* **97**, 2813 (1992); Y-T. Chen, D.M. Watt, R.W. Field, and K.K. Lehmann, *J. Chem. Phys.* **88**, 4819 (1988); D. M. Jonas, S. A. B. Solina, B. Rajaram, R. J. Silbey, R. W. Field, K. Yamanouchi and S. Tsuchiya, *J. Chem. Phys.* **99**, 7350 (1993); Y. M. Engel, R. D. Levine, Y. Chen, R. W. Field, J. L. Kinsey, and J. P. Pique, *J. Chem. Phys.* **88**, 5972 (1988); N. Ikeda, S. Tsuchiya, D. M. Jonas, J. K. Lundberg, G. W. Adamson, K. Yamanouchi, and R. W. Field, *J. Chem. Phys.* **95**, 6330 (1991).
26. Y-T. Chen, D. M. Watt, R. W. Field, and K. K. Lehmann, *J. Chem. Phys.* **88**, 4819 (1988); D. M. Watt, R. W. Field, K. K. Lehmann, and Y-T. Chen, *J. Chem. Phys.* **93**, 2149 (1990).
27. X. Yang, C.A. Rogaski, and A.M. Wodtke, *J. Chem. Phys.* **92**, 2111 (1990); X. Yang and A.M. Wodtke, *J. Chem. Phys.* **93**, 3723 (1990); D. M. Jonas, Z. Yang and A. M. Wodtke, *J. Chem. Phys.* **97**, 2284 (1992)
28. J.E. Baggott, M-C. Chaung, R. N. Zare, H.-R. Dübal, and M. Quack, *J. Chem. Phys.* **82**, 1186 (1985); J. Segall, R. N. Zare, H. R. Dübal, M. Lewerenz, and M. Quack, *J. Chem. Phys.* **86**, 634 (1987).
29. Y. S. Choi and C. B. Moore, *J. Chem. Phys.* **90**, 3875 (1989).
30. L. Lapierre, H. L. Dai, D. Fyre, *J. Chem. Phys.* **89**, 2609 (1989); H. L. Kim, J. D. McDonald, and S. A. Reid, *J. Chem. Phys.* **92**, 7079 (1990).
31. W.H. Green, W.D. Lawrance, and C.B. Moore, *J. Chem. Phys.* **86**, 6000 (1987).
32. P. Hofmann, R.B. Gerber, M.A. Ratner, L.C. Baylor, and E. Weitz, *J. Chem. Phys.* **88**, 7434 (1988).
33. D.C. Tardy and B.S. Rabinovitch, *Chem. Rev.* **77**, 369 (1977); M. Quack and J. Troe, *Gas Kinetic and Energy Transfer* **4**, 73 (1981); M. Quack and J. Troe, *Int. Rev. Phys. Chem.* **1**, 97 (1981).
34. H. Hippler, J. Troe, and H.J. Wendelken, *J. Chem. Phys.* **78**, 6709 (1983); Hippler, J. Troe, and H.J. Wendelken, *J. Chem. Phys.* **78**, 6718 (1983); M. Heymann, H. Hippler, and J. Troe,

- J. Chem. Phys. **80**, 1853 (1984); M.J. Rossi, J.R. Pladzewics, and J.R. Barker, J. Chem. Phys. **78**, 6695 (1983); J.R. Barker, J. Phys. Chem. **88**, 11 (1984); W. Forst and J.R. Barker, J. Chem. Phys. **83**, 124 (1985).
35. J.E. Dove, H. Hippler, and J. Troe, J. Chem. Phys. **82**, 1907 (1985).
 36. B.J. Orr, J.G. Haub, G.F. Nutt, J.L. Steward, and O. Vozzo, Chem. Phys. Lett. **78**, 621 (1981); B.J. Orr, J.G. Haub, and R. Haines, Chem. Phys. Lett. **107**, 168 (1984); C.P. Bewick, A.B. Duval, B.J. Orr, J. Chem. Phys. **82**, 3470 (1985); J.G. Haub and B.J. Orr, J. Chem. Phys. **86**, 3380 (1987); C.P. Bewick and B.J. Orr, J. Chem. Phys. **93**, 8634 (1990); C.P. Bewick, J.P. Martins, and B.J. Orr, J. Chem. Phys. **93**, 8643 (1990).
 37. B.L. Chadwick, D.A. King, L. Berzins, and B.J. Orr, J. Chem. Phys. **91**, 7994 (1989); B.L. Chadwick, A. P. Milce and B. J. Orr, Chem. Phys. **175**, 113 (1993).
 38. W.D. Lawrance and A.E.W. Knight, J. Chem. Phys. **79**, 6030 (1983); J.W. Thoman, S.H. Kable, A.B. Rock, and A.E.W. Knight, J. Chem. Phys. **85**, 6234 (1986); S.H. Kable and A.E.W. Knight, J. Chem. Phys. **86**, 4709 (1987).
 39. J. Wu, R. Huang, M. Gong, A. Saury and E. Carrasquillo, J. Chem. Phys. **99**, 6474 (1993).
 40. F. Temps, S. Halle, P.H. Vaccaro, R.W. Field, and J.L. Kinsey, J. Chem. Phys. **87**, 1895 (1987); F. Temps, S. Halle, P.H. Vaccaro, R.W. Field, and J.L. Kinsey, J. Chem. Soc. Faraday Trans. **84**, 1457 (1988); P.H. Vaccaro, F. Temps, S. Halle, J.L. Kinsey, J. Chem. Phys. **88**, 4819 (1988); S. L. Coy, S. D. Halle, J. L. Kinsey and R. W. Field, J. Mol. Spec. **153**, 340 (1992).
 41. J. Pliva, J. Mol. Spec. **44**, 165 (1972); G. Strey and I.M. Mills, J. Mol. Spec. **59**, 103 (1976).
 42. J.K.G. Watson, M. Herman, J.C. Van Craen, and R. Colin, J. Mol. Spec. **95**, 101 (1982); K.C. Ingold and G.W. King, J. Chem. Soc. (London), 2702 (1953).
 43. G.J. Scherer, Y. Chen. R.L. Redington, J.L. Kinsey, and R.W. Field, J. Chem. Phys. **85**, 6315 (1986).
 44. M. D. Fritz, Ph.D. Thesis, University of Wisconsin, 1993.
 45. X. W. Zhan and L. Halonen, J. Mol. Spec. **160**, 464 (1993).
 46. X. Luo and T.R. Rizzo, J. Chem. Phys. **93**, 8620 (1990); X. Luo, P.R. Fleming, T.A. Seckel, and T.R. Rizzo, J. Chem. Phys. **93**, 9194 (1990); P. R. Fleming, M. Li and T. R. Rizzo, J. Chem. Phys. **94**, 2425 (1992). P. R. Fleming, M. Li and T. R. Rizzo, J. Chem. Phys. **95**, 865 (1991); X. Luo and T. R. Rizzo, J. Chem. Phys. **96**, 5129 (1992); X. Luo, P. R. Fleming and T. R. Rizzo, J. Chem. Phys. **96**, 5659-5667 (1992); M. Li, T. R. Rizzo, P. R. Fleming, J. Chem. Phys. **95**, 865 (1991).
 47. B. R. Foy, J. C. Stephenson, D. S. King, and M. P. Casassa, J. Chem. Phys. **94**, 250 (1991).
 48. A. McIlroy and D. J. Nesbitt, J. Chem. Phys. **91**, 104 (1989).
 49. J. D. Tobiasson, M. D. Fritz, and F. F. Crim, (in preparation).
 50. P. Varanasi and B. R. P. Bangaru, J. Quant. Spectrosc. Radiat. Transfer **15**, 267 (1975); J. S. Wong, J. Mol. Spec. **82**, 449 (1980).

51. See E. A. Rohlfing, D. W. Chandler, and D. H. Parker, *J. Chem. Phys.* **87**, 5229 (1987) for one of the first examples of this approach.
52. L. J. Butler, T. M. Ticich, M. D. Likar and F. F. Crim, *J. Chem. Phys.* **85**, 233-5, 6251 (1986)
53. R. E. Teets, F. V. Kowalski, W. T. Hill, H. Carlson, and T. W. Hänsch, *SPIE Laser Spectroscopy* **113**, 31 (1977).
54. Y. Chen, D. M. Jonas, J. L. Kinsey, and R. W. Field, *J. Chem. Phys.* **91**, 3976 (1989).
55. D.E. Reisner, R.W. Bield, J.L. Kinsey, and H-L. Dai, *J. Chem. Phys.* **80**, 5968 (1984).
56. H-L. Dai, C.L. Korpa, J.L. Kinsey, and R.W. Field, *J. Chem. Phys.* **82**, 1688 (1985).
57. A. M. Wodtke (private communication).
58. D.J. Krajnovich, C.S. Parmenter, D.L. Catlett, Jr., *Chem. Rev.* **87**, 237 (1987).