

Carderock Division Naval Surface Warfare Center

Bethesda, Md. 20084-5000

CARDIVNSWC-TR-61-94/29 August 1994

Survivability, Structures, and Materials Directorate
Technical Report

Evaluation of Electrochemical Noise to Monitor Corrosion for Double Hull Applications

by
John N. Murray

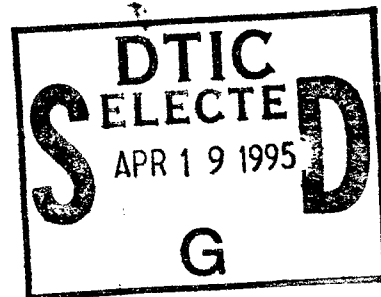

19950418 028

DTIC QUALITY INSPECTED 1



Approved for public release; distribution is unlimited.

**Carderock Division
Naval Surface Warfare Center**

Bethesda, Md. 20084-5000

CARDIVNSWC-TR-61-94/29 August 1994

Survivability, Structures, and Materials Directorate
Technical Report

**Evaluation of Electrochemical Noise to Monitor
Corrosion for Double Hull Applications**

by
John N. Murray

Accession For	
NTIS CRA&I	<input checked="" type="checkbox"/>
DTIC TAB	<input type="checkbox"/>
Unannounced	<input type="checkbox"/>
Justification	
By	
Distribution /	
Availability Codes	
Dist	Avail and/or Special
A-1	

Approved for public release; distribution is unlimited.

ABSTRACT

The possibility of utilizing the two electrochemical noise (EC Noise) parameters, voltage (E_n) and current (I_n) noise, as a means for identifying the status of an organic barrier coating on steel was investigated. The intent was to demonstrate that this non-destructive evaluation (NDE) approach provides a meaningful signal for the assessment of the status of coatings as had been suggested previously by Chen and Skerry¹. The classical EC Noise technique, which is normally applied to a segmented electrode or a pair of electrodes, had to be modified to simulate the configurations expected in the field. The modified approach involved evaluation of the coated sample noise relative to a reference electrode, the I_n limited by a blocking resistor necessary to allow measurement of the E_n values. The evaluation included measurements in a conventional test laboratory environment and within a Faraday cage. These two conditions were intended to simulate a coated hull in a drydock and coatings inside tanks and double hull void spaces. Seven different coating samples were selected from panels available from other Carderock Division, Naval Surface Warfare Center (CARDEROCKDIV, NSWC) programs, the samples having been continuously exposed to aerated substitute ocean water for up to 4 years. In addition, the possibility of utilization of coated, closely spaced, interdigitated electrode elements as corrosion sensors in non-immersion, double hull applications was also pursued.

Using a commercially available EC Noise system, increased sample E_n values were measured for coatings which had potentials suggesting greater corrosion protection. However, the amount of E_n signal was a function of the reference/counter electrode type, and was significantly reduced when the sample and leads were located within the Faraday cage. The largest voltage variation was measured when recording sample potentials at a 0.1 second frequency for up to 400 seconds, the limit of the particular data storage program. A low frequency voltage wave was documented for all samples tested outside the cage, the magnitude of this E_n wave not being measured by the commercial EC Noise system. Presuming the high impedance coated samples and equipment leads are acting as antennas, the source of the observed low frequency wave (which changed for the different types of coatings) was not identified. However, one characteristic of a good coating was that it allowed more local noise than a marginal or poor coating.

E_n data from the coated panel samples placed within the Faraday cage were small, up to 100 μ V. Although the trend was the same as with the samples tested outside the cage, whether this signal is sufficient for evaluations in the field requires verification.

Testing a latex and an epoxy coating on closely spaced, silver electrode, interdigitated sensors in different relative humidity atmospheres using Electrochemical Impedance Spectroscopy (EIS) was successful. However, the results from the EC Noise parameter, limited to the I_n value, were conflicting. The I_n value was higher for the epoxy coating and the uncoated sensor at 100% Relative Humidity (RH) but lower for the latex-coated sensor. Possibly the limitation here was with respect to interaction of the coating and the moisture with the silver fingers. A more consistent I_n signal should result from an iron or steel/coating interface. A measurable shift in EIS characteristics occurred and could be related to the relative humidity in the test environment. Changes could be detected at relative humidities as low as $\leq 50\%$. In that atmospheric corrosion rates become minimal

at < 50% RH, the coated interdigitated sensor modified to include a reference electrode element would appear to be directly applicable for the monitoring of double hull interior spaces.

CONTENTS

	Page
Abstract	iii
Administrative Information and Acknowledgments	vi
Administrative Information	vi
Acknowledgments	vii
Introduction	1
Experimental	6
EC Noise	6
DC Resistance, DC Electrochemistry and EIS	7
Sensors	9
Results and Discussion	11
EC Noise	11
<i>Benchtop Tests</i>	11
<i>Faraday Cage Results</i>	20
DC Resistance and EIS	23
Sensors	23
<i>EIS Testing</i>	24
<i>Sensors and EC Noise Testing outside Faraday Cage</i>	29
<i>Sensors and EC Noise Testing inside Faraday Cage</i>	30
Summary	30
Conclusions	36
Proposed Areas For Additional Work	37
References	38

FIGURES

1. Schematic view of the classic EC noise experimental set-up.	2
2. Schematic view of the modified EC noise experimental set-up for two electrodes.	3
3. Sensor electrode schematic designs.	5
4. Schematic view of the modified Bacon ¹³ DC resistance set-up.	8
5. Plan view of uncoated Time of Wetness (TOW) sensor. (scale in picture: 0.03125 inch/div. upper, 0.0156 inch/div. lower)	10
6. E_n time values from S-6, a MIL-P-2444, type 1, epoxy coatings after 4 years continuous immersion.	12
7. 400 seconds of potential-time values from S-6, a MIL-P-24441, type 1 epoxy polyamide coating after 4 years continuous service.	13

8. Expanded view, 300–350 seconds of experiment time shown in Figure 7.	14
9. Potential-time runs from NCEL coatings—4.2 years continuous immersion exposure.	15
10. Potential-time runs from cast urethane coatings—0.5 years continuous immersion exposure	16
11. Comparison of sample E_n and E_{corr} values (samples outside Faraday cage). . .	18
12. Comparison of sample E_n and E_{wave} values (samples outside Faraday cage). .	19
13. Potential-time runs with 0.317 cm thick cast urethane coating.	21
14. Comparison of E_n values from samples placed inside or outside Faraday cage. .	22
15. EIS bode magnitude response of latex coated sensors in 29, 75, or 100% relative humidity atmosphere.	25
16. EIS bode magnitude response of epoxy coated sensors in 29, 75 or 100% relative humidity atmosphere.	26
17. EIS bode magnitude response of uncoated sensors in 29, 75 or 100% relative humidity atmosphere.	27
18. Cross-section view of uncoated sensor showing height and width of metal fingers on substrate.	28
19. 100% RH, Z_{max} with time for uncoated, latex and epoxy coated sensors.	31
20. 75% RH, Z_{max} with time for uncoated, latex and epoxy coated sensors.	32
21. EIS bode magnitude response of uncoated, latex and epoxy coated sensors in 29% relative humidity atmosphere.	33
22. 29% RH, Z_{max} with time for uncoated, latex and epoxy coated sensors.	34

TABLES

1. Comparison of voltage noise values by E-time and EC noise techniques.	17
2. Comparison of voltage noise values with Z_n and Ag/AgCl reference/counter-electrodes. Sample URE/E-C.	20
3. Comparison of voltage noise values in and outside the Faraday cage (zinc reference/counter electrode).	23
4. DC resistance and selected EIS parameter values.	24
5. Summary of I_n values from sensors outside cage in 100% and 29% RH conditions.	30

ADMINISTRATIVE INFORMATION AND ACKNOWLEDGMENTS

ADMINISTRATIVE INFORMATION

This project was funded by the Office of Naval Research (ONR) Code ONR 334, technical point of contact, J. Gagorik. The work was performed under Work Unit 1-6600-062 as part of the Advanced Double Hull Technology Project RH21S11, PE 602121N and satisfies Milestone 4 of Task 15; Inspection, Maintenance and Repair, Prin-

cial Investigator, M. Gallagher (NAVSSSES, Philadelphia, Code 1240). The effort was conducted at the Carderock Division of the Naval Surface Warfare Center (CARDEROCKDIV, NSWC) in the Marine Corrosion Branch, Code 613 under the supervision of Mr. Robert J. Ferrara, Code 613 Branch Head.

ACKNOWLEDGMENTS

One pint samples of the MIL-P-28577A and MIL-P-28578B latex primer and latex topcoat paints were provided for evaluation purposes by the Spraylet Corp. (Chicago, IL). D.W. Smith (Code 613) performed the preliminary sensor preparation and sensor coatings were applied at CARDEROCKDIV, NSWC Code 641 by A.M. Ross. The text was critically reviewed by H.P. Hack and R.A. Hays (Code 613).

INTRODUCTION

The concept for characterizing the status of organic barrier coatings by the technique known as electrochemical noise measurements was apparently first published by Chen and Skerry in 1991¹. Many have observed that the potential of an excellently coated steel surface relative to a reference electrode (eg. Ag/AgCl) tends to be a positive value *and* tends to be quite "noisy". Noise in this particular case refers to the standard deviation of the coating potential (E_n) as observed over an arbitrary but roughly 5 minute time period. Typically potential values of $+0.2 \pm 0.1$ V are observed for an undamaged conventional MIL-P-24441, type 1 epoxy polyamide coated steel sample exposed to aerated substitute (or real) ocean water. A voltmeter with a high internal impedance is needed to observe these "noisy" potentials (E_n). A satisfactory meter has a minimum input impedance of $10^{10} \Omega$, whereas a preferable meter has a $\geq 10^{12} \Omega$ input impedance, such as the Kiethley Model 617 Programmable Electrometer (specifications $> 2 \times 10^{14} \Omega$ in parallel with 20 pF). At the other extreme, a poor or damaged barrier coated steel surface in aerated substitute (or real) ocean water exhibits a potential of approximately -0.625 ± 0.005 V, i.e., one observes the stable steady state of corroding steel. Chen and Skerry suggested a correlation exists between these two extremes which could be useful in describing the status of the coating system¹.

The appeal of the technique is at least three fold: 1) the measurement of E_n requires no applied signal and is therefore a truly NDE technique; 2) the measurements are obtained reasonably rapidly, and are simple and easily interfaced with a field portable computer and 3) the measuring tools are relatively inexpensive (ca \$4,000 for voltmeter and PC).

The classic EC Noise technique as initially applied to uncoated or coated metals involves more than just the determination of the standard deviation of the voltage signal. The classic EC Noise experimental set-up is shown schematically as Figure 1 with two coated samples (identically prepared), each with an electrolyte reservoir positioned on the surface. The two samples are electronically connected through a zero resistance ammeter (ZRA) and ionically connected by use of an electrolyte bridge which usually contains the same solution as is in the electrolyte reservoirs. The ZRA allows measurement of currents which are generated on one surface by an anodic (or corrosion) current "burst", a portion of which passes through the ZRA to the opposing electrode. Simultaneously, by the use of a reference electrode in one of the electrolyte chambers and a high impedance voltmeter, one measures the potential noise presumed to correspond with the current noise. The classic technique is well suited to the study of the initiation and propagation of pitting, as seen in one early (1980) study using both current and potential measurements on pitting of aluminum². Possibly the earliest publication regarding EC Noise measurements was in 1968 but was limited to potential noise measurements³. The uniqueness of (at least) voltage noise was recognized by the US Patent Office with the issuing of US 4,575,678⁴ on 11 March 1986 (applied for 5 Jan 1983). The use of the ratio of the potential noise (E_n) to the current noise (I_n), referred to as the Noise Resistance (R_n) may be attributed to Eden⁵. In an ideal sense, if one measures the potential noise, and somehow the current noise is truly representative of the processes occurring at the samples, then R_n , obtained without disturbing the samples in any way, should be the same as the polarization resistance (R_p), used in calculating the corrosion current via the application of the Stern-Geary equation⁶.

The question does remain with respect to the amount of generated current which is measured in the external circuit as opposed to that which is consumed at nearby areas of each sample to charge local surface capacitances or be consumed by local cathodic processes (assuming the currents in general coming from the sample are essentially anodic).

There is an initial problem of applying the research laboratory electrode pair EC Noise technology to measuring the electrochemical noise from painted Navy structures. A hull or a ballast tank is not electrically segmented, thus one has only one coated surface. Therefore, an initial modification would be to monitor the painted surface relative to only a reference electrode. This allows measurement of the E_n value. However, I_n may be the more relevant signal for the detection on the onset of coating breakdown. Again one might couple a reference electrode through a ZRA to the coated panel sample area. For most "good" organic barrier coatings, this would shift the "natural" potential of the coated area to that of the reference electrode presuming the coating impedance were in the $10^{10} \Omega \cdot \text{cm}^2$ range, thus eliminating the voltage noise signal. An alternative is to use two reference electrodes, one for monitoring the natural potential noise, the second coupled with a very high value resistor through the ZRA to the coated structure for measuring a partial quantity of the sample current. The value of the current limiting resistor should be greater than 10X the coating impedance to minimize any significant shift of the coated area potential. A schematic for this set-up is presented in Figure 2.

If one is considering measuring EC noise, then one should select some rational data sampling frequency. If data were sampled at, say, 1 data set per second for 1 hour, the task of storing and analyzing 3,600 data sets (V, I and time) is large but not unreasonable. At 10 data sets per second, the problem becomes larger and starts to strain the data accumu-

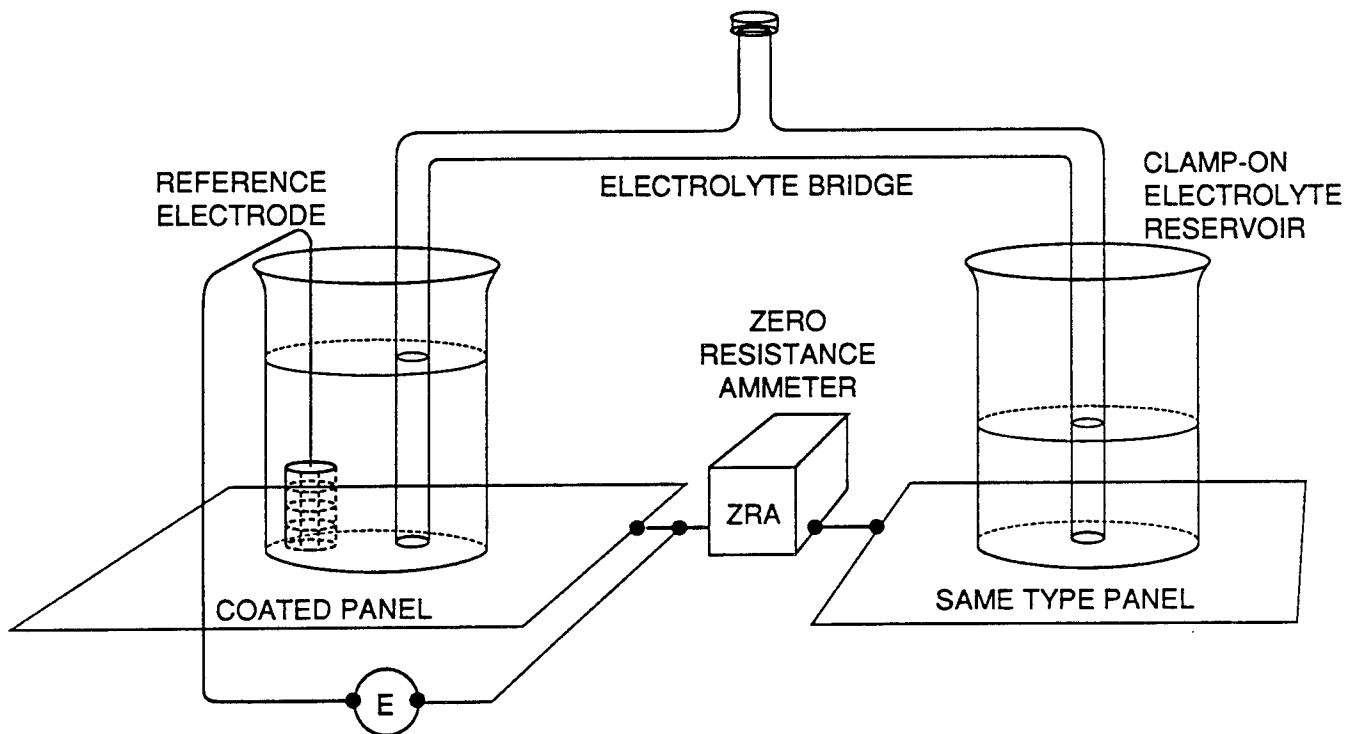

Figure 1. Schematic view of the classic EC noise experimental set-up.

lation capability of the accompanying inexpensive computer/ data acquisition system. This problem is being solved by the vendors of EC Noise monitoring equipment in two distinct ways. Capcis March, Ltd., the assignee of the EC Noise US patent⁴, essentially supplies a huge computer and stores all of the accumulated data. Gamry Instruments' system samples shorter blocks of data (up to 4,000 data sets), treats this data, calculates an average E_n and I_n , stores the averaged values and then continues. The computer requirements are more in line with a conventional PC in this latter approach.

As shown in the schematic Figures 1 and 2, measurement of the EC noise parameters (as with most measurements in electrochemistry), occurs with samples immersed in electrolytes. The proposed advanced double hull design for Naval combatants has many interior cavities that are essentially dry. Therefore, the applicability of any electrochemical technique for monitoring the onset and extent of corrosion in non-immersion voids is questionable. As an alternative, removable test coupons could be periodically visually assessed and replaced for subsequent re-evaluation. Electrical resistance style corrosion probes could also be used for continuous monitoring of the void conditions, although experience with coated resistance probes has not been reported. There has been some limited electrochemical monitoring of organic coatings in non-immersion conditions where the organic phase was considered as the "electrolyte". Mansfeld⁷ reported electrochemical measurements through paint films placed as coatings over bimetallic time-of-wetness (TOW) sensors. A schematic of their bimetallic TOW design is given in Figure 3a. Mansfeld has stated that his research group did not obtain sufficiently useful information, and concluded that any measurements would be associated with the polymer sensor electrode(s) interface rather than through the polymer. Simpson, Moran, et.al.⁸ ap-

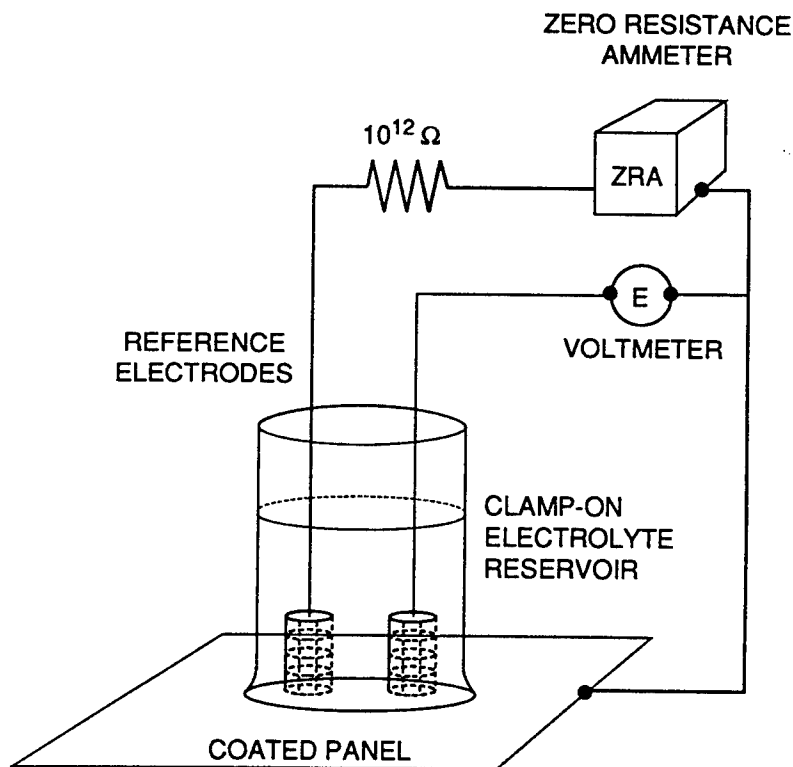

Figure 2. Schematic view of the modified EC noise experimental set-up for two electrodes.

proached the problem somewhat differently, as shown schematically in Figure 3b. Parallel, thin, flat, interdigitated electrodes were deposited on the top, or atmospheric, side of a painted steel panel and the investigators were able to monitor polymer breakdown through the polymer via electrochemical impedance spectroscopy (EIS) as the samples were exposed to atmospheric environments which simulated acid rain. The sensors yielded useful data at a 1 ppm SO₂, 95% relative humidity (RH) atmosphere but the data suggested the particular design might respond only above 80% RH. Murray⁹ conducted some preliminary experiments with a commercial TOW sensor chip where the interdigitated fingers were deposited quite close together on an alumina substrate and coated with a commercial latex. EIS data showed a reasonable change in coating capacitance as well as the emergence of a diffusional element as the latex coating dried. Kranbuehl¹⁰ used a similar interdigitated two electrode design to monitor the drying of epoxy paints in a variety of atmospheric conditions and showed the slowness of drying at temperatures less than 55 F with high humidities. Therefore, three of four investigators were able to demonstrate the possibility of using an electrochemical technique and sensor to monitor the status of a coating system.

There are several other electrochemical techniques for evaluating organic barrier coatings which are or have been under investigation at CARDEROCKDIV, NSWC and other facilities. These include measuring the coating capacitance¹¹, the holiday population per unit area¹², the dc resistance of the coating¹³, the dielectric loss index¹⁴ and the coating impedance over a variety of frequencies (EIS)^{8,9}. This report will be primarily limited to a presentation of the EC Noise data with corresponding data presented from some of the alternative techniques to provide the reader with some sense of the applicability and usefulness of the EC Noise technique.

There were several objectives for this 6 month effort. They are (in no particular order):

1. Demonstrate if the EC Noise technique relates to the condition of organic barrier coating systems,
2. Demonstrate if the two electrode (sample area and reference electrode) EC noise technique results in reasonable data relative to a three electrode (two sample areas and a reference electrode) set-up,
3. Demonstrate the usefulness of the coated, closely spaced interdigitated detector with EC Noise, determining if E_n or I_n is more useful and comparing the behavior with that obtained using EIS,
4. Demonstrate the coated, closely spaced interdigitated detector does allow electrochemical signals at various relative humidities and
5. Demonstrate other relationships between EC Noise parameters and other electrochemical measurements.

As a convenience to the reader, the EXPERIMENTAL and RESULTS AND DISCUSSION sections have been segmented into sections for EC Noise; for DC Resistance, DC electrochemistry and EIS; and for Sensors.

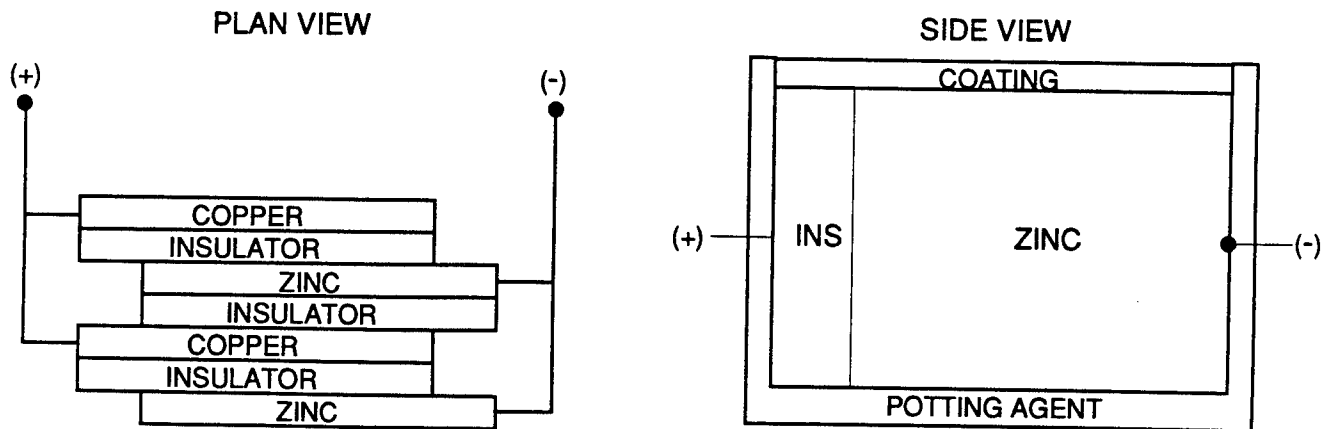

a) Bimetallic TOW approach per Mansfield, et al.⁷

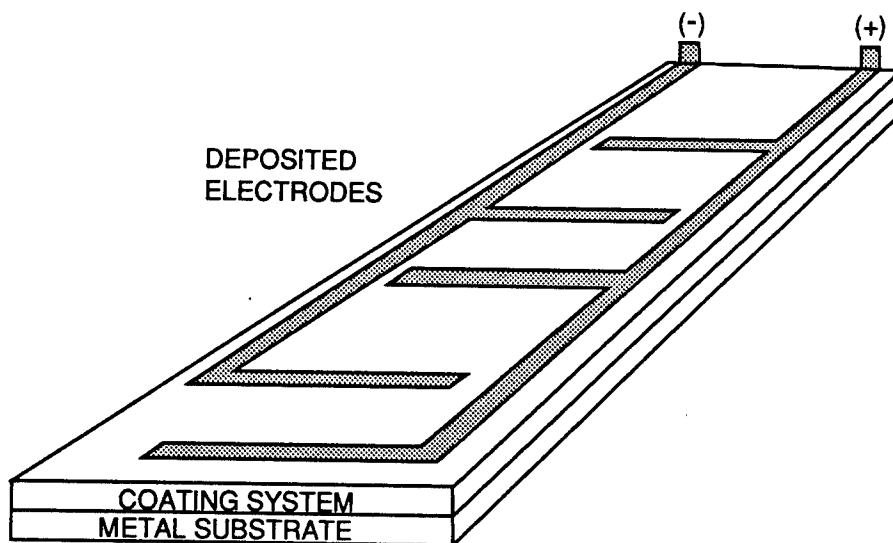

b) External interdigitized finger electrodes per Simpson, et al.⁸

Figure 3. Sensor electrode schematic designs.

EXPERIMENTAL

EC NOISE

A commercially available EC Noise system was procured from Gamry Instruments for use in this evaluation project. The Gamry system consists of a portable 486, 33 MHz PC with 4 MB RAM, 120 MEG Hard Drive and 64k CACHE, and a gas discharge monitor. The PC was reconfigured internally to include the Gamry PC3 Potentiostat/Galvanostat/ZRA Board Set, a PC3/ECM8 Cell Cable and Auxiliary A/D Cable, the CMS100 "FRAMEWORK" System Software (Ver. 2.05D), the CMS105 "DC Corrosion Techniques" Software (Ver. 2.05) and the CMS120 "Electrochemical Noise Software (Ver. 2.05). As the gas discharge monitor was judged to be quite unsatisfactory, a conventional SVGA color monitor was added to the Gamry system to assist in reading the software text and in observations of on-line data accumulation. The Gamry unit was selected over the Westinghouse/Capcis-March system because of cost considerations for this evaluation project. The Westinghouse/Capcis-March system was reportedly available only including engineering assistance with its associated costs. An EG&G, Princeton Applied Research (PAR) Model 273 or 273A Potentiostat with the PAR Model 252 software could have been utilized for this evaluation but only with modifications to the PAR Model 388 software. The PAR equivalent system cost was significantly higher than the Gamry system.

The Gamry EC Noise measurement software is relatively straightforward. Rather than accumulate the data continuously during a defined experimental time, short clusters of data are gathered periodically during the overall time. The Windows-driven menus allow the experimenter to select: a) the total time of the experiment (limited to 4000 data points); b) the sampling "block" or cluster period and frequency of data collection during the block period (default conditions of 4 second blocks and 0.05 second samplings for a total of 80 points/block); c) the amount of time for the repeat (default 0.25 min = 15 sec); and d) any delay period prior to initial sampling. While being collected, data are visually displayed in real time. The collection of data is then analyzed to determine the average current and voltage as well as the deviations, ie., the E_n and I_n values. The screen is then cleared and the E_n and I_n values are maintained on an updated experiment summary time plot until the next block period. The program output is essentially a documented final plot of the E_n and I_n values with several report options including printing the calculated averaged E_n and I_n values.

The cell and wiring schematic for the conventional EC Noise experiments was presented as Figure 1. The modifications to allow the two electrode experiments (sample surface and reference electrode) were presented in Figure 2. The inclusion of the $10^{12} \Omega$ resistor in-line between the electrometer and the reference electrode essentially uncouples the electrode pair while allowing current measurements with the sensitive ZRA. Although this approach allows one to monitor the E_n values of the sample surface, the I_n values are considerably retarded. Alternative DC measurement techniques are available within the other Gamry CMS100 software and will be discussed shortly.

The majority of the EC Noise data was taken with the samples positioned on top of a conventional laboratory bench. After experimentally resolving several issues as to the "proper" approach for a two electrode evaluation of a coated surface, the question was raised regarding the influence of stray electrical signals and the impact on the overall

data. The use of samples placed within a Faraday cage had not been found necessary for previous EIS testing using the PAR electronics but had been advised for testing with a more sensitive, development, EIS system. An 18 x 18 x 36 inch long Faraday cage was fabricated from conventional lumber and anodized aluminum window screen. Several samples were reevaluated in and out of the cage with and without the cage screen grounded. As detailed in the "RESULTS" section below, significant changes in the EC Noise values were observed. Therefore, Faraday shielding may be necessary in the field for evaluations of outside hull surfaces. However, the interiors of double hull spaces (as well as ballast tank and CHT tanks) should essentially be the same as the interior of a Faraday cage as long as there is no other signal generator operating within that space.

DC RESISTANCE, DC ELECTROCHEMISTRY AND EIS

The DC resistances of the coating systems were measured using a slight modification to the Bacon approach¹³. A schematic is shown in Figure 4. A series of high value precision resistors were sequentially connected between the reference electrode and the coated sample, the reference electrode being in the same electrolyte as the coated sample area. Using a high input impedance electrometer, the open-circuit potential of the coated sample is initially recorded. Depending on the input impedance of the electrometer and the coating resistance value, the initial readings could require up to 15 minutes to stabilize with stability meaning that the observations of EC Noise had no potential drift. One of the resistors was then introduced into the circuit as shown in Figure 4 and the difference between the potential of the reference electrode and the sample area (voltage across the resistor) was recorded. The DC resistance of the coating was then calculated via Eqn. 1 and is normalized by multiplying by the sample area (in cm²).

$$R_c = R_m * \left[\frac{E_{ocv}}{E_{load}} - 1 \right] * A \quad (1)$$

where

R_c is the coating resistance in units of Ohms* area (cm²);

R_m is the measuring resistor; E_{ocv} is the panel to reference electrode open circuit potential;

E_{load} is the potential drop across the measuring resistor as well as the voltage of the panel area relative to the reference electrode when a current drain occurs, and

A is the cell defined area of the coating.

The Gamry CMS120 Electrochemical Noise system also contained the CMS100 Corrosion Measurement System software for the use of up to 12 other DC measurement techniques to confirm the EC Noise results. The techniques selected for supplementary testing included the E_{corr} vs. time and the galvanic corrosion routines. The galvanic corrosion electronics were reported to be somewhat distinct from the ZRA electronics used for the EC Noise measurements.

EIS measurements were also taken for comparison with the E_n and I_n values. The EIS system consisted of a PAR Model 273 potentiostat, an EG&G Model 5206 Lock-in

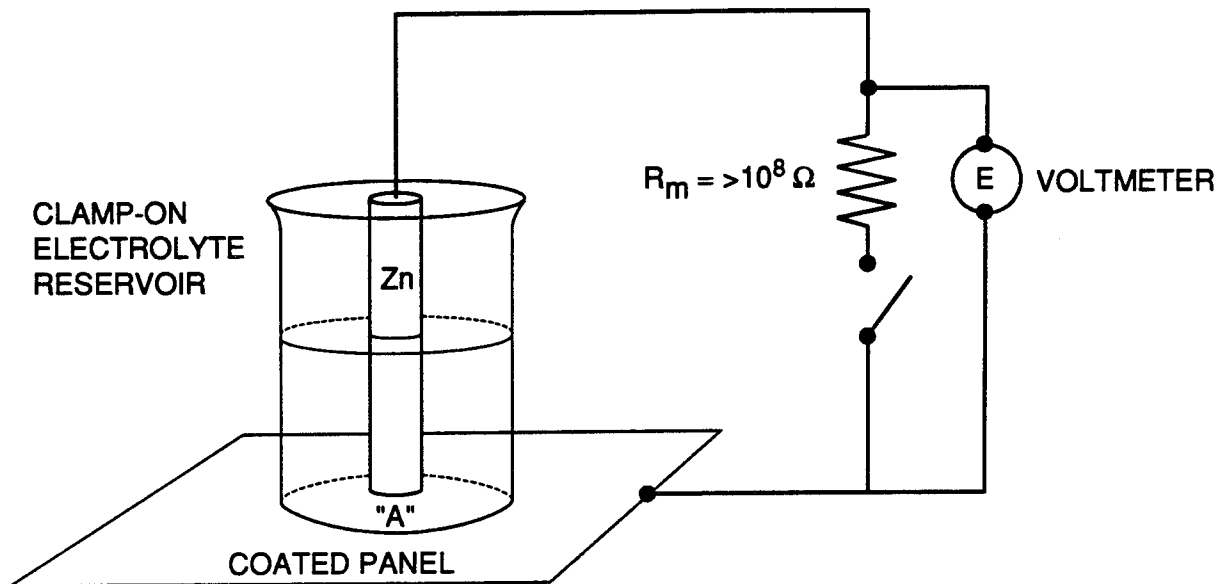

$$R_c = R_m * \left[\frac{E_{ocv}}{E_{load}} - 1 \right] * A$$

Where $R_c \equiv$ coating resistance, $R_m \equiv$ measured resistor, $A \equiv$ coated panel area in reservoir.
 $E_{ocv} \equiv$ Panel to reference open circuit voltage,
 $E_{load} \equiv$ Panel to reference closed circuit or load voltage.

- Notes: 1) Zn electrode assumed unpolarized
 2) Load resistors; $10e8 - 10e12\Omega$
 3) Voltmeter impedance $\gg R_m$

Figure 4. Schematic view of the modified Bacon¹³ DC resistance set-up.

Analyzer, a conventional PC and the PAR Model 388 software. The general operation and analysis theory have been published previously by many, including CARDEROCKDIV, NSWV personnel¹⁵. The input voltage signal was limited to 5 mV for a frequency range of 5 mHz to 100 kHz.

A variety of organic barrier coated steel samples have been in immersion at CARDEROCKDIV, NSWV for up to 5 years with visual assessments and EIS measurements made periodically. Much of the data concerning the coating systems and general behaviors have been published previously^{15,16}. These panels were used to characterize the EC Noise data relative to EIS and the other DC measurement techniques.

SENSORS

Surplus two electrode TOW sensors purchased previously as part of another program were outfitted with electrical leads, coated on both planar surfaces, and evaluated at three different humidity levels. A typical plan view of an uncoated TOW sensor is shown in Figure 5. The spacing between the deposited silver fingers was 0.02 cm., the overall sensor size being 2.5 x 2.5 cm. The finger electrodes were deposited only on one surface of the alumina substrate. The corrosion current developed from the silver fingers was expected to be considerably less than from iron or steel fingers but the intent was to demonstrate there was a detectable signal that changed with the atmospheric moisture level and with exposure time. Following DC resistance measurements with a Kiethley Model 617 Multimeter and EIS runs, the samples were prepared for the exposure tests by first coating the "backside" with a thick commercial epoxy. The EIS and DC resistance values were then determined after the epoxy had dried between 2 and 4 days in conventional laboratory conditions.

Three other sensors were spray coated with a MIL-P-28577B acrylic latex primer and then a MIL-P-28578B acrylic latex semigloss topcoat. Coating application parameters were in accordance with the MIL-P-28577B and MIL-P-28578B standards.

Three additional sensors were spray coated with the organic components (without pigments) for the MIL-P-24441, type 1 epoxy-polyamide coating system, this transparent coating having been used at CARDEROCKDIV, NSWV in many evaluations of substrate corrosion. Primer and topcoat layers were prepared from the same paint mix after allowing 4 hours of drying between coats. Although the pot life for this system is between 6 and 8 hours depending on room ambient temperature and humidity, the final appearance of the coating was alligatored. Unfortunately, there was insufficient time to repeat the preparation and the sensors were used in the as-prepared condition.

The final three sensors were left in the uncoated condition, but included the "backside" epoxy coating as applied to the six, previously discussed, coated sensors.

One sensor from each of the above types was subsequently placed into a covered 1.5 liter, polycarbonate vessel and exposed to a closed, air atmosphere humidified by an open beaker of deionized water or by constant humidity solutions. The three conditions were then, 100% RH (water), 75% RH (saturated NaCl solution) and 29% RH (saturated CaCl₂). The initial changes of the sensors were monitored with EIS, with EC Noise used only after some general knowledge of coating and sensor stability had been acquired.

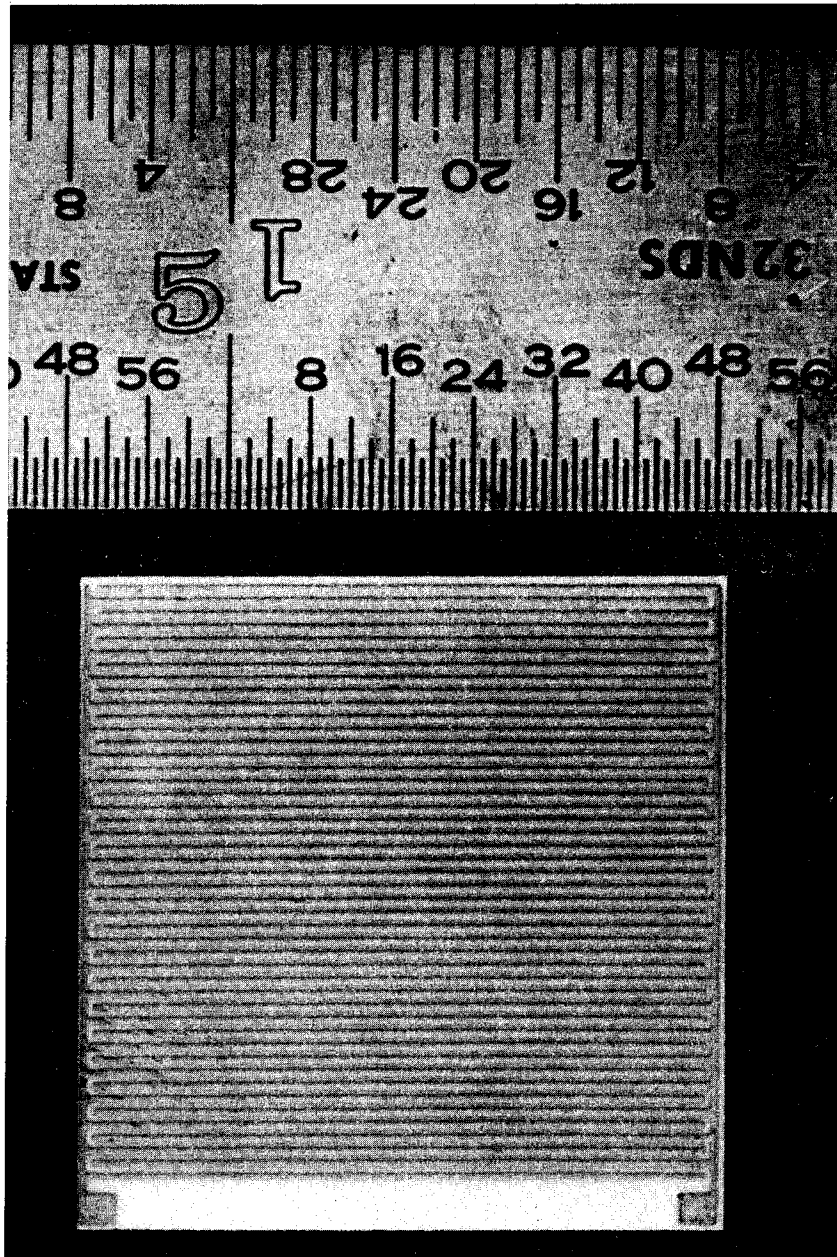

Figure 5. Plan view of uncoated Time of Wetness (TOW) sensor.
(Scale in picture: 0.03125 inch/div. upper, 0.0156 inch/div. lower)

RESULTS AND DISCUSSION

EC NOISE

Benchtop Tests

The E_n data collected from a 3.5 year old, MIL-P-24441, type 1 epoxy coating on steel, which had been evaluated weekly during that immersion exposure period using visual and EIS measurements, are shown in Figure 6. The experimental set-up was that shown in Figure 2. There were no blisters or rust spots apparent on the coating surface. The E_n values averaged 16 mV.

The sample potentials as a function of time determined using the Gamry Galvanic Corrosion (GGC) software are shown in Figure 7. Excluding the spikes which will be discussed shortly, the GGC data show a potential spread of +112 mV, this higher range brought about by the low frequency wave (3 cycles/400 sec) that is superimposed on the higher frequency data. The considerably lower levels of " E_n " via the EC Noise approach are the result of capturing four second bursts of voltage data every 30 sec, this approach "inadvertently" omitting the low frequency data. As an example, the data for the 50 sec period between 300 and 350 sec of GGC are presented as Figure 8 where it can be seen that the fine structure is that of ± 38 mV, still higher than the EC Noise value from the noise run but closer by virtue of excluding the low frequency wave. Included in the Figure 8 data are large excursions, the result of physical disturbance of the sample and the disturbance of the local area magnetic fields by, for example, people moving past the sample. Arm waving within about 6 feet of the sample also produced current and voltage noise signals.

The low frequency wave should be related to the status of the coating system. GGC data from three distinct types of coating systems, all exposed to aerated ASTM-D-1141 substitute ocean water for 4.2 years are presented in Figure 9. Figure 9a shows the data from an intact MIL-P-24441, Type 1 three layer epoxy coating and, in general, the behavior is similar to that shown previously in Figure 7, although the coating average potential of -0.25 V vs Ag/AgCl was more electronegative. The noise range including the low frequency wave was ± 60 mV, roughly half that seen for the S-6 epoxy coating sample. Figure 9b shows data from an intact, MIL-C-85285 polyurethane topcoat over a MIL-P-24441, type 1, epoxy primer also after 4.2 years exposure. Although there is no observed damage to the coating, the average potential of -0.507 V vs Ag/AgCl would suggest ionic conduction through the coating to an underlying substrate which may have a slow corrosion process. The potential noise range as seen in Figure 9b was ± 17 mV. Finally, data from an acrylic topcoated inorganic zinc/epoxy primer also exposed for 4.2 years are shown in Figure 9c. The average sample potential was -0.659 V vs Ag/AgCl and the noise range was ± 24 mV.

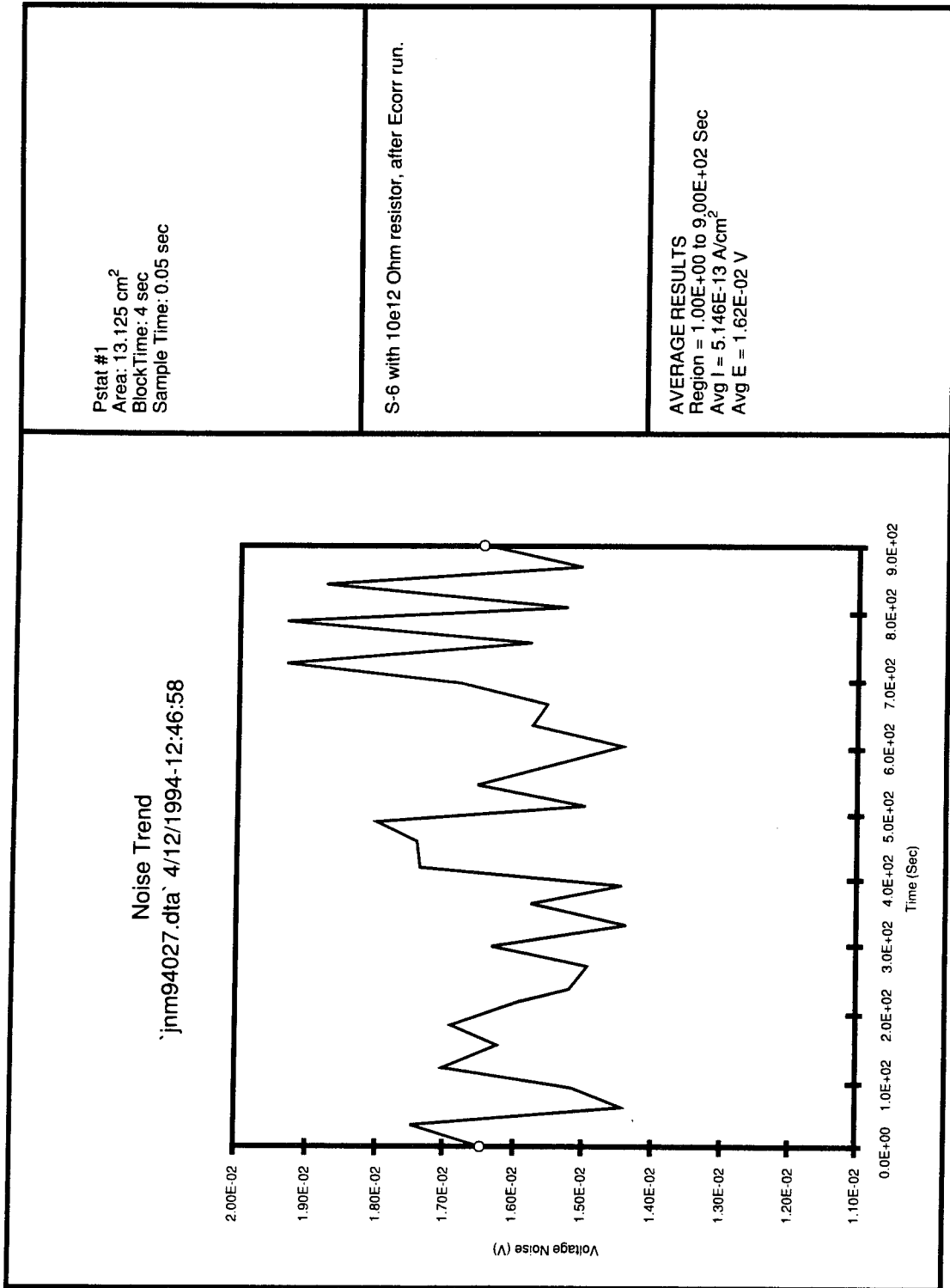

Figure 6. E_n time values from S-6, a MIL-P-2444, type 1, epoxy coatings after 4 years continuous immersion.

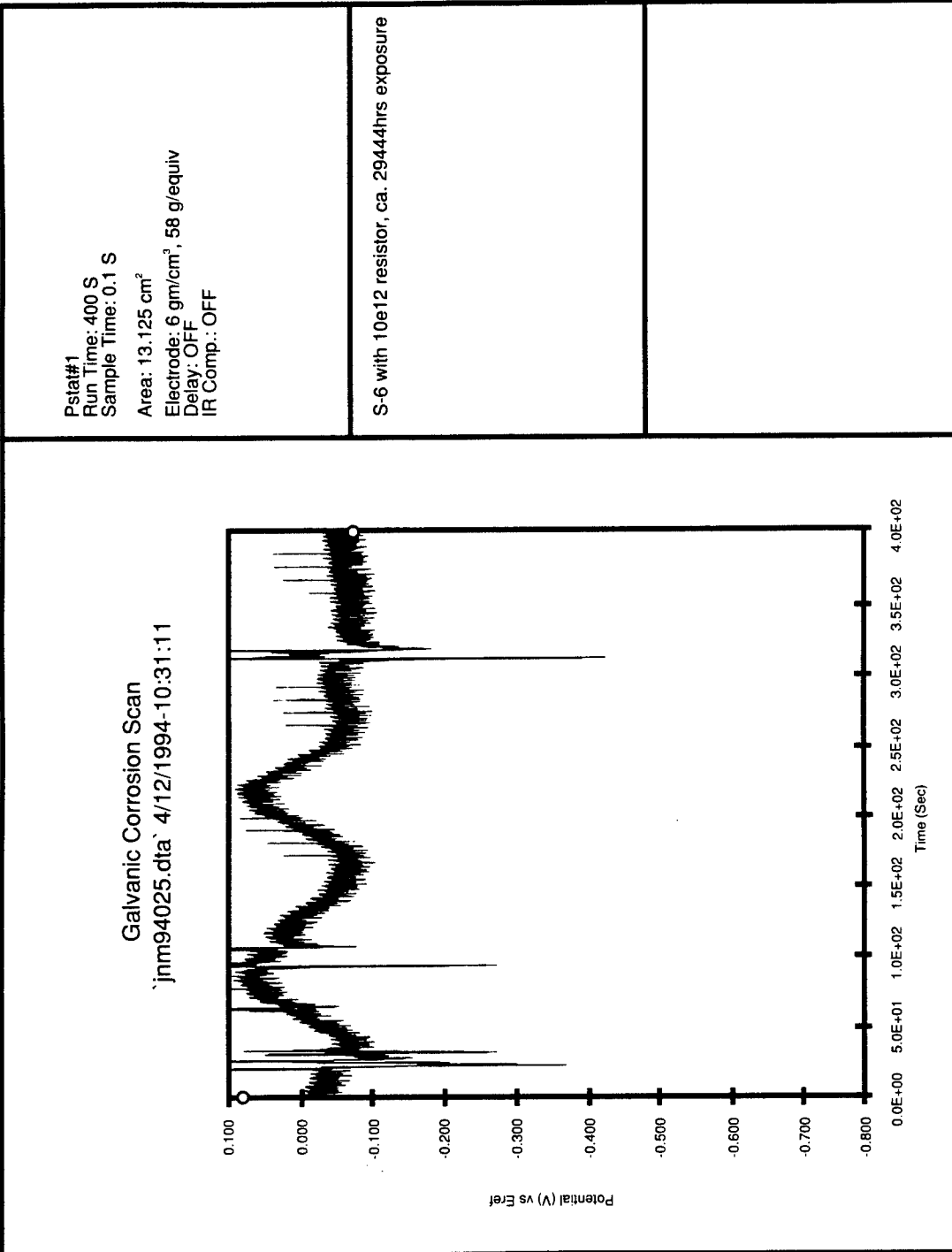
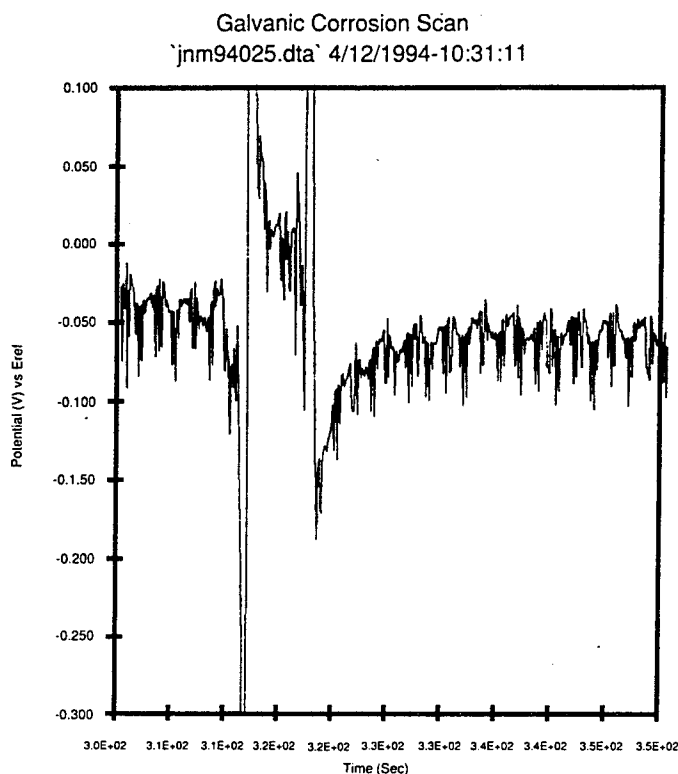

Figure 7. 400 seconds of potential-time values from S-6, a MIL-P-24441, type 1 epoxy polyamide coating after 4 years continuous service.

Figure 8. Expanded view, 300–350 seconds of experiment time shown in Figure 7.



data from a set of different thickness polyurethanes cast on transparent epoxy primer coated steel are presented in Figure 10. All three of these coatings were in excellent condition at the time of this evaluation and again, the low frequency wave was evident. Figure 10a shows the potential of the 1580 μm thick (1/16 inch) urethane on epoxy primer to be $0.075 \text{ V} \pm 35 \text{ mV}$ vs Ag/AgCl. The equivalent data from the 3175 μm thick (1/8 inch) casting are shown in Figure 10b; the potential being $0.121 \text{ V} \pm 53.5 \text{ mV}$ vs AgCl. Finally, the data from the thickest casting (6350 μm , 1/4 inch) are presented in Figure 10c, where the potential was $0.080 \text{ V} \pm 80.1 \text{ mV}$ vs Ag/AgCl.

EC Noise measurements were taken at the same time for the majority of the samples and the measurements were repeated roughly 6 weeks later. As indicated earlier, the Gamry system algorithms do not account for the low frequency waves. The comparison between the " E_n " values obtained with the two approaches discussed thus far is given in Table 1, the listing given in order of decreasing sample potentials. The second set of data was obtained using a zinc reference/counter electrode and the values in the table were recalculated for a Ag/AgCl reference. Although there is no actual physical damage evident on any of these samples, an argument can be made suggesting an increase in corrosion as the potentials become more negative. The correlation between the second set of data and the sample potentials is presented in Figure 11. Although a regression line can be drawn through the data, the presence of the one noisy ("good", i.e., high resistance) sample skewed the linear regression analysis. Elimination of that one noisy point lowers the fit line considerably as shown in the figure. Therefore, the Chen/Skerry postulation appears to hold when using the Gamry EC Noise approach although the trend appears more satisfactory when one includes the low frequency wave data. A comparison of the fits is summarized in Figure 12.

Galvanic Corrosion Scan
`jnm94031.dta` 4/14/1994-7:47:40

NC2825D with 10e12 resistor. Was -0.258 vs. Ag/AgCl, 1.04e11 dc Ohms @ 37027hrs.

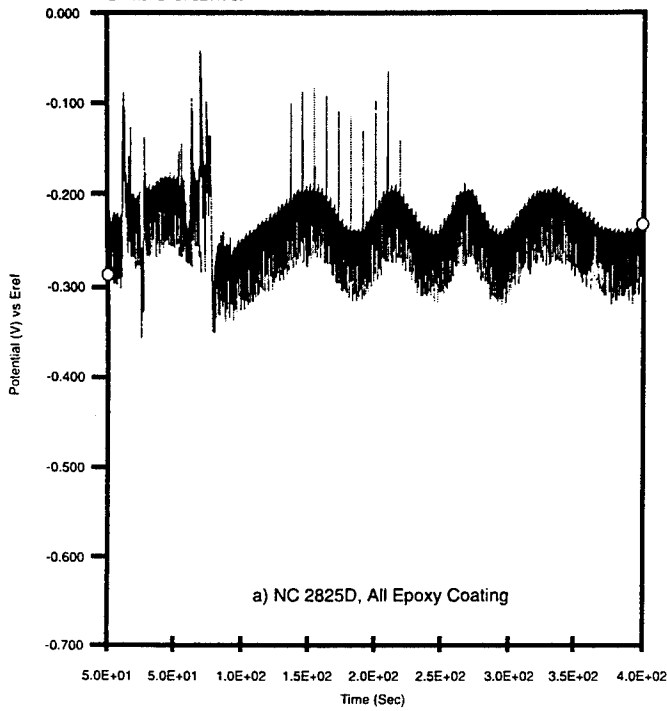

Galvanic Corrosion Scan
`jnm94034.dta` 4/14/1994-11:1:50

NC2519D with 10e12 resistor. Was -0.491 vs. Ag/AgCl, 1.7e8 dc Ohms, @ 37015hrs.

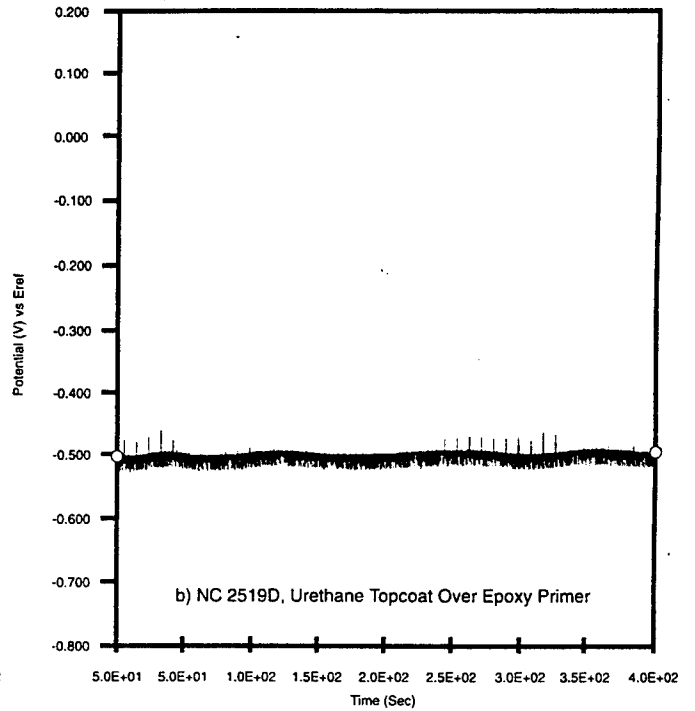

Galvanic Corrosion Scan
`jnm94037.dta` 4/14/1994-13:20:3

NC3230D with 10e12 resistor. Was -0.643 vs. Ag/AgCl, 9.5e7 dc Ohms, @ 37012 hours exposure.

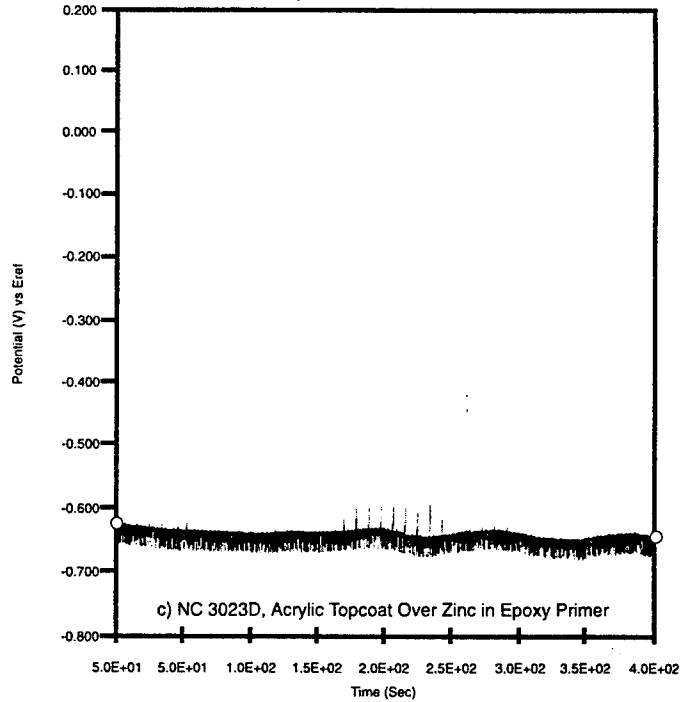

Figure 9. Potential-time runs from NCEL coatings—4.2 years continuous immersion exposure,

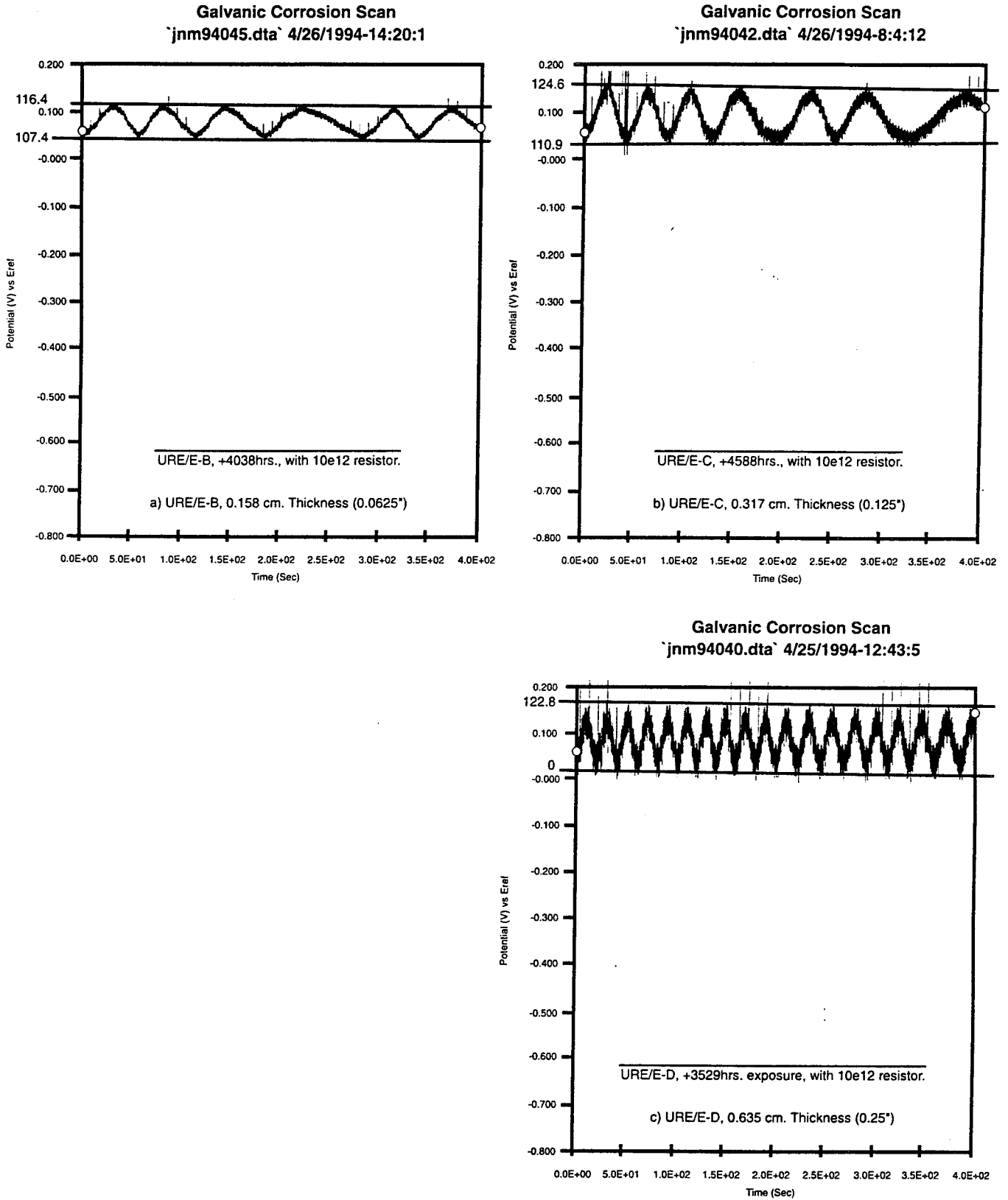

Figure 10. Potential-time runs from cast urethane coatings—0.5 years continuous immersion exposure

Table 1. Comparison of voltage noise values by E-time and EC noise techniques.

<u>Sample</u>	<u>Gamry Blocked Galvanic Data</u>				<u>EC Noise Values (mV)</u>	<u>Run Ref. #</u>	<u>GGC/ECN</u>
	<u>Average Potential¹ (Volts)</u>	<u>Potential Range (mV)</u>	<u>Low Frequency Wave ?</u>	<u>Run Ref. #</u>			
URE/E-C	0.121	± 67	yes	94042	± 10.2	94044	6.6
"	0.082 ²	± 35	"	94114	± 14.4	94131	2.5
URE/E-D	0.080	± 80	yes	94040	± 22.4	94041	3.6
"	0.122 ²	± 177	"	94129	± 89.2	94127	2.0
URE/E-B	0.075	± 40	yes	94045	± 3.9	94046	10.3
"	0.127 ²	± 25	"	94113	± 4.4	94112	5.7
S-6	-0.00175	± 100	yes	94025	± 16	94027	6.3
"	0.027 ²	± 35	"	94159	± 11.7	94160	3.0
NC2825D	-0.250	± 60	yes	94031	± 26	94033	2.3
"	-0.438 ²	± 46	"	94141	± 14.1	94140	3.3
NC2519D	-0.507	± 17	no	94034	± 7.6	94036	2.2
"	-0.530 ²	± 10	yes	94142	± 4.3	94143	2.3
NC3230D	-0.659	± 24	no	94037	± 11.3	94039	2.1
"	-0.514 ²	± 15	yes	94158	± 4.3	94157	3.5

1. With respect to Ag/AgCl reference electrode.
2. Corrected from Zn to Ag/AgCl.

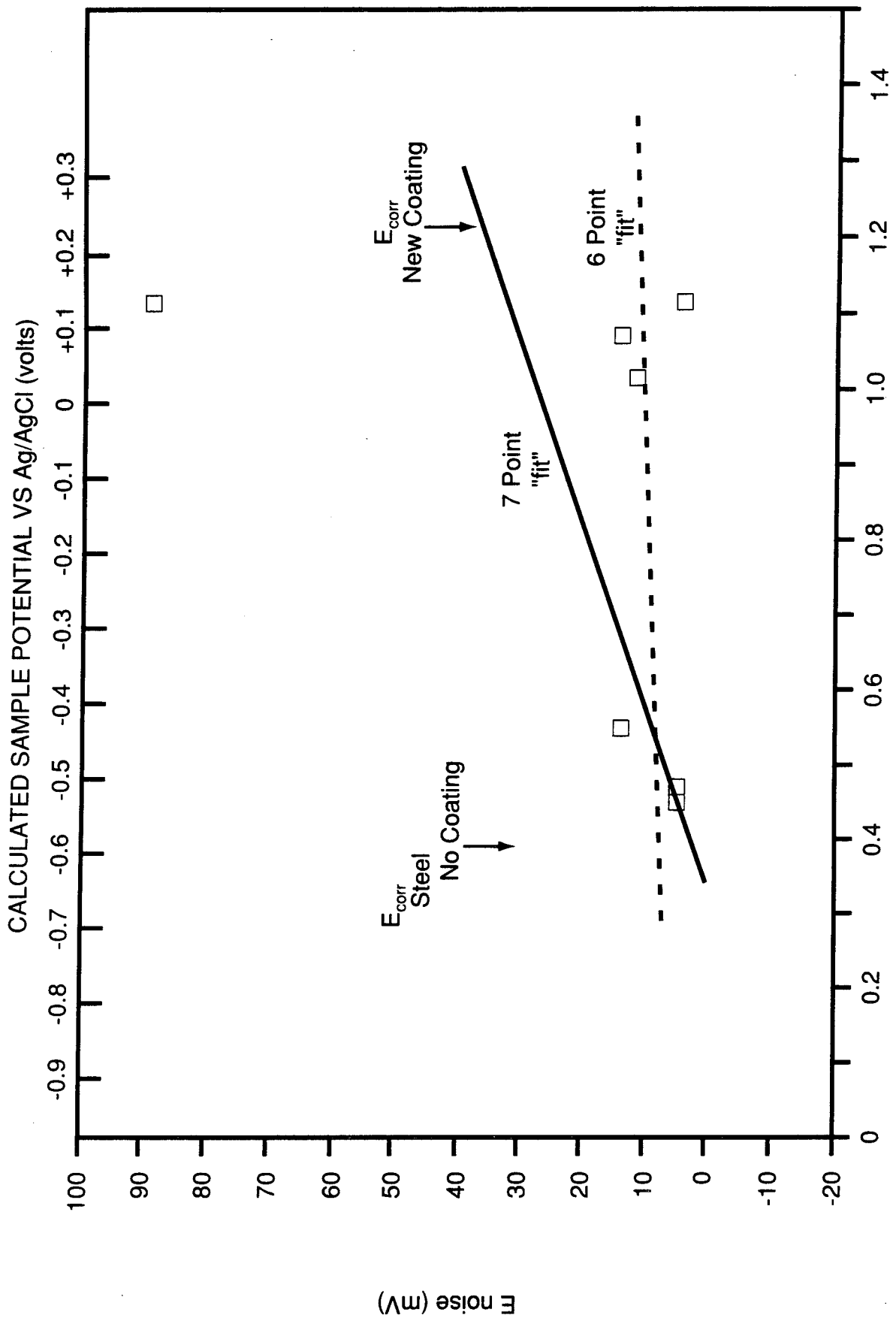

Figure 11. Comparison of sample E_n and E_{corr} values (samples outside Faraday cage).

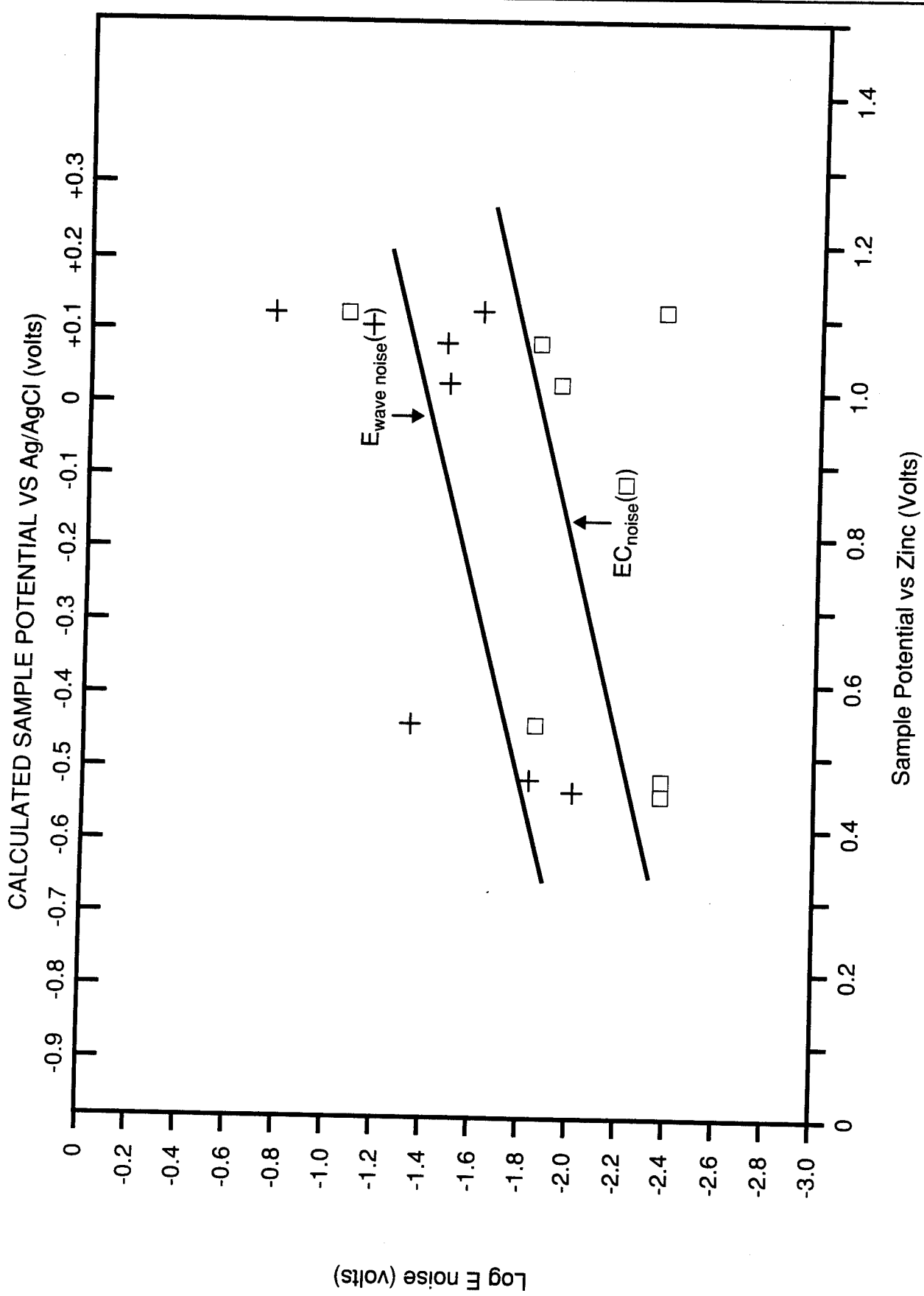

Figure 12. Comparison of sample E_n and E_{wave} n values (samples outside Faraday cage).

The minimal fit using the Gamry EC Noise values which did not include the low frequency wave was disappointing. As indicated in the last column, the two approaches tend to converge as the samples attain more electronegative potentials. At the steel corrosion potential, the Gamry algorithm is probably correct in that it is a true average over the 4 second data collection period. The analysis of the GGC data is rather an average of the max/min cases and therefore should be higher.

The reference electrode noise level was investigated using two Ag/AgCl basket style reference electrodes in the conventional EC Noise set-up. The average potential for the baskets was 0.0025 V vs. a saturated calomel reference electrode (SCE) with a variation of only ± 1.5 mV; the equivalent EC Noise values were 0.475 mV, smaller by a factor of roughly 3. The low levels of these noise signals show that the source of the measured noise in Table 1 and the previous discussions is primarily the coated electrode. Next, the noise level using a zinc electrode was compared to that measured when using a Ag/AgCl basket reference. Both sets of data, summarized in Table 2, were obtained on the same calendar date but roughly 7 hours apart. The values shown suggest a higher noise level using the zinc electrode.

Table 2. Comparison of voltage noise values with Z_n and Ag/AgCl reference/counterelectrodes. Sample URE/E-C.

Reference Electrode	Gamry Blocked Galvanic Data				EC Noise Values (mV)	Run Ref. #	GGC/ECN
	Average Potential (Volts)	Potential Range (mV)	Low Frequency Wave ?	Run Ref. #			
Ag/AgCl	0.110	± 15	Yes	94130	5.5	94131	2.7
Zn	-1.029	± 35	Yes	94114	14.4	94115	2.4

Several of the segmented atmospheric sensor elements were evaluated with EC-Noise and the GGC approach, and that data will be presented in the sensor section.

Faraday Cage Results

M.R. Yaffe from Gamry Instruments suggested a system grounding modification in which the Faraday cage ground was linked to the system potentiostat (p-stat) card ground via the black lead from the cell cable. Four complimentary runs were then made with the seven coatings. There were also two choices for locating the reference electrode lead and both alternatives were evaluated.

The results from positioning the reference electrode and grounding the p-stat card are summarized in Figure 13 for a sample outside or inside the Faraday Cage. The Faraday cage reduced the voltage noise level by a factor of about 100. The low frequency wave (somewhat different in shape from that shown earlier) was also eliminated using the cage. Replicate runs for the seven coatings were also made outside the cage within about one hour of the runs within the cage and the low frequency wave was again detected when the samples were placed outside the cage. The comparison of the seven "outside" vs., "inside" E_n values is shown in Figure 14.

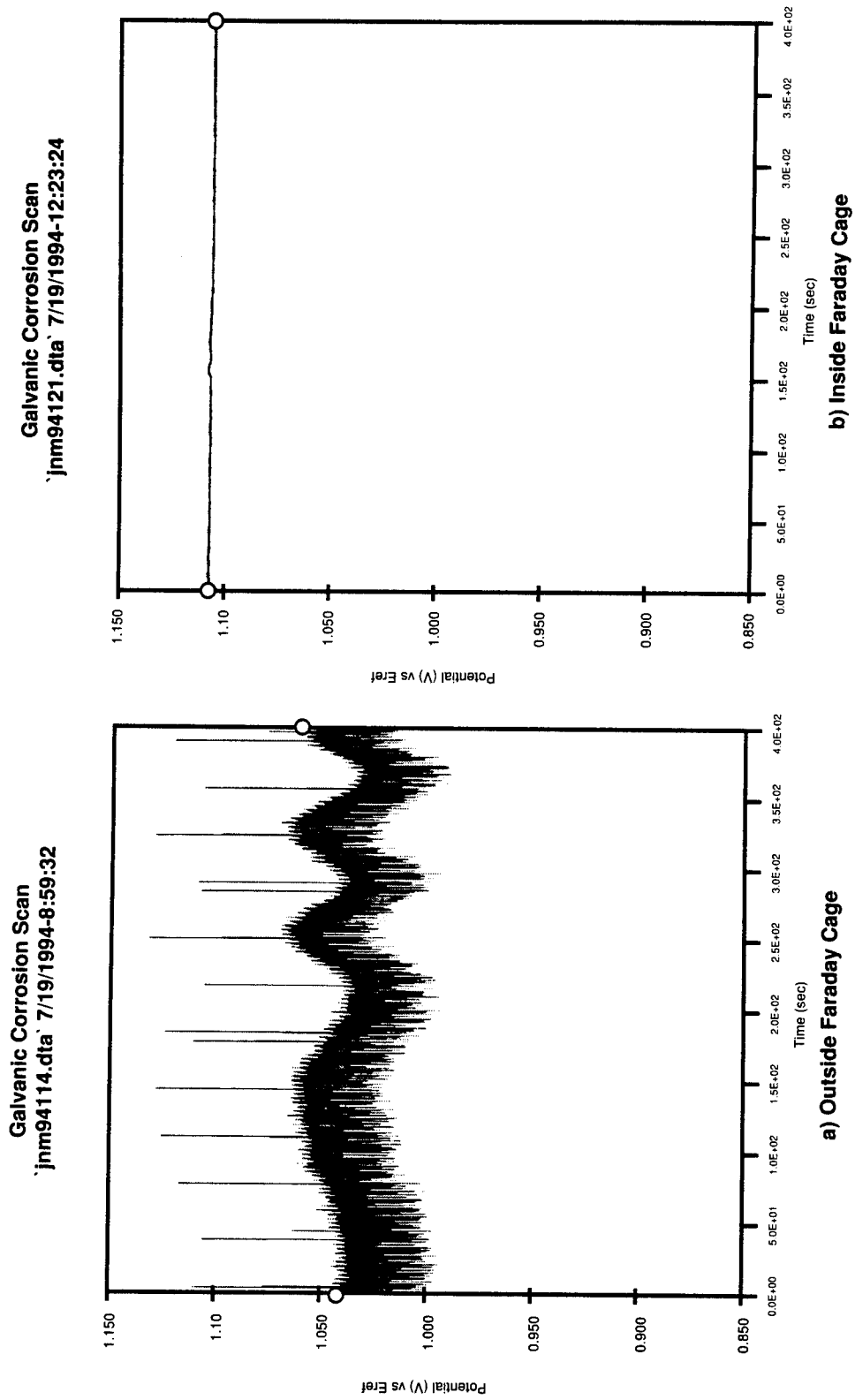

Figure 13. Potential-time runs with 0.317 cm thick cast urethane coating.

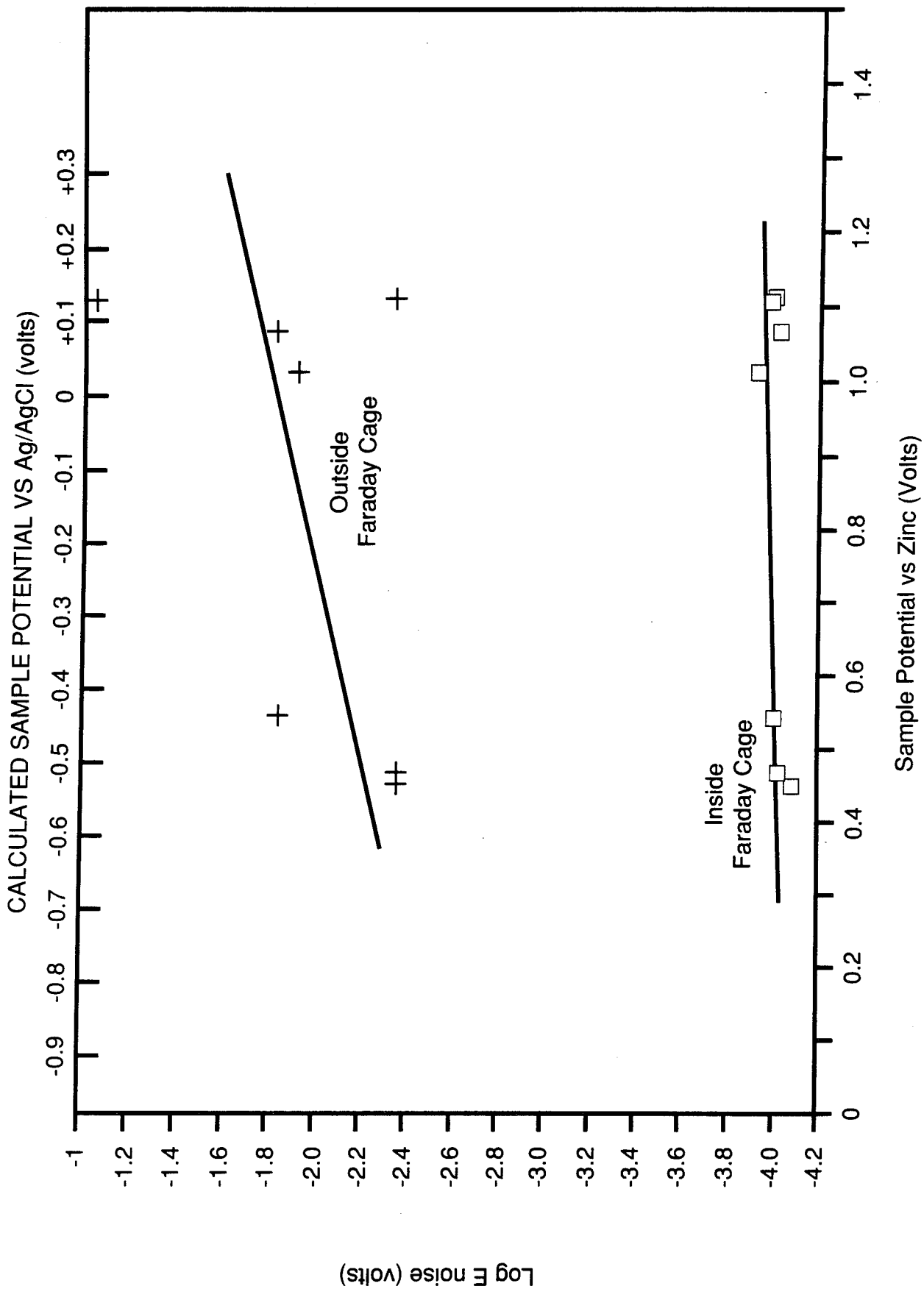

Figure 14. Comparison of E_n values from samples placed inside or outside Faraday cage.

A comparison of the potential noise (E_n) data inside and outside the Faraday cage is presented in Table 3. Differences observed with the E_n values for the outside the cage cited previously in Table 1 may be due to the grounded p-stat card as well as changes in the local area noise.

Table 3. Comparison of voltage noise values in and outside the Faraday cage (zinc reference/counter electrode).

<u>Sample</u>	<u>Outside Cage</u>		<u>Inside Cage</u>		<u>Out/In</u>
	<u>EC Noise</u> <u>(Volts)</u>	<u>Reference</u>	<u>EC Noise</u> <u>(Volts)</u>	<u>Reference</u>	
URE/E-D	89×10^{-3}	94127	1.0×10^{-4}	94123	892
URE/E-C	14×10^{-3}	94115	9.4×10^{-5}	94120	153
URE/E-B	4.4×10^{-3}	94112	9.9×10^{-5}	94106	44
S-6	11×10^{-3}	94160	1.1×10^{-4}	94165	103
NC 2825D	14×10^{-3}	94140	9.9×10^{-5}	94135	142
NC 2519D	4.3×10^{-3}	94143	8.3×10^{-5}	94148	52
NC 3230D	4.3×10^{-3}	94157	9.4×10^{-5}	94151	46

DC RESISTANCE AND EIS

As indicated in the introduction, alternatives to the use of EC Noise for monitoring coating status include DC resistance monitoring and the use of the more wide range EIS technique. All the samples tested with the Gamry unit were also evaluated within approximately the same day using the DC resistance approach shown in Figure 2 and the PAR 388 EIS system. The relative values for the seven coating systems as measured in July 1994 are summarized in Table 4. The dc resistance values agree reasonable well with the maximum impedance (Z_{max}) values from the EIS runs and should be more correct as the measuring limits of the EIS system with this 31.2 cm² cell area are approximately $3 \times 10^{10} \Omega \cdot \text{cm}^2$. The Table 4 values may then be compared with the E_n values given in Table 3 obtained at approximately the same time. The correlation between E_n and dc resistance values is approximately the same as the correlation between E_n and the E_{corr} values shown previously in Figure 11.

SENSORS

Testing of the sensors was performed with three different relative humidity (RH) values, each humidified tank containing a latex coated, an epoxy coated and an uncoated sensor.

Table 4. DC resistance and selected EIS parameter values.

Sample	Average Potential ¹ (Volts)	DC Resistance ($\Omega \cdot \text{cm}^2$)	EIS Parameters			Ref. #
			Capacitance (pF/cm ²)	Z _{max} ($\Omega \cdot \text{cm}^2$)	f _{M, hi} (Hz)	
URE/E-D	0.122	3.3x10 ¹⁰	1.9	1.1x10 ¹⁰	8	94290
URE/E-C	0.082	1.2x10 ¹⁰	3.4	1.3x10 ¹⁰	28	94291
URE/E-B	0.127	2.6x10 ⁹	6.9	1.9x10 ⁹	126	94295
S-6	-0.024	2.7x10 ¹⁰	35.8	7.6x10 ¹⁰	0.54	94304
NC 2825D	-0.438	3.4x10 ¹⁰	28.0	1.1x10 ¹⁰	0.5	94315
NC 2519D	-0.530	5.4x10 ⁷	104.5	4.6x10 ⁷	36.5	94318
NC 3230D	-0.514	1.2x10 ⁸	82.9	9.1x10 ⁷	23.9	94319

1. Recalculated to Ag/AgCl reference from Zn values.

EIS Testing

Typical EIS Bode magnitude results for the latex coated sensors at the three distinct humidities and after approximately 15 days exposure are presented as Figure 15. The impedance values are given in Ohms rather than $\Omega \cdot \text{cm}^2$ in that the true sample area has not been established. The sensor impedance values were inversely related to the RH levels with possibly no change in measured impedance for the 29% RH case relative to the initial measurements when the sensor was dry. This corresponds with atmospheric corrosion data which normally shows very little corrosion when the RH values drop below 50%. However for the case of a sensor in a marine environment, the 75% RH being the water vapor evolved from a saturated NaCl solution, the low frequency impedance clearly decreases by over one order of magnitude.

The equivalent epoxy coated sensor EIS results are presented as Figure 16. Again the presence of 75% RH lowers the low frequency impedance by an order of magnitude whereas the 29% RH atmosphere did not affect the polymer coating relative to the initial dry condition. The results from the uncoated sensors are given in Figure 17 and here only the 100% RH level influences the low frequency impedance.

There is a question as to what volume of coating is responding to the EIS analysis. If one calculates the average increase in coating capacitance for the epoxy coated sensors relative to the uncoated sensors, a coating area of 0.24 cm² (0.05 cm thickness) would result, this being roughly 10% of the overall area of the polymer between the interdigitized fingers. This low percentage would suggest the electronically active volume is only about the height of the fingers, 0.0011 cm as seen in the cross-section photograph, Figure 18.

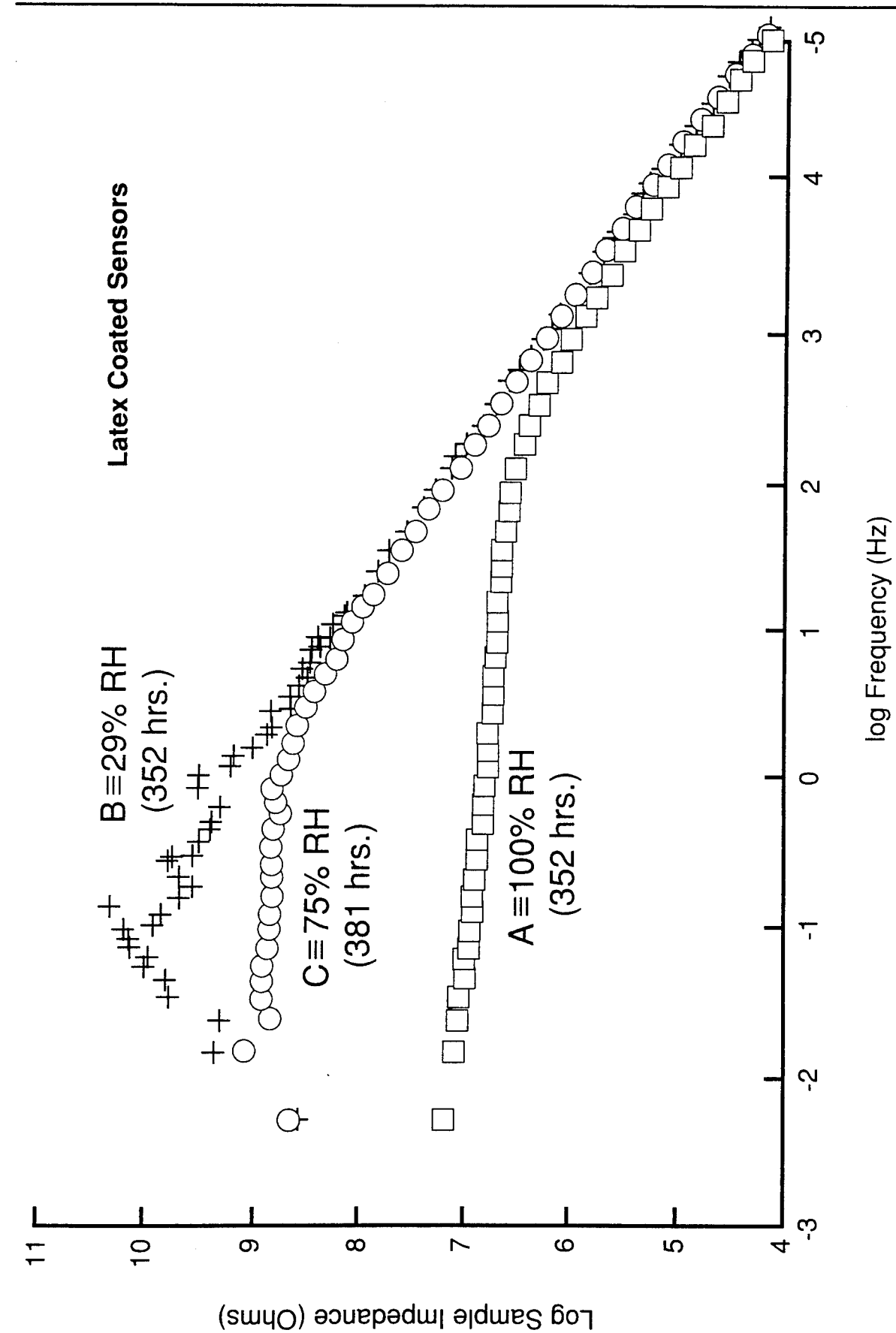

Figure 15. EIS bode magnitude response of latex coated sensors in 29, 75, or 100% relative humidity atmosphere.

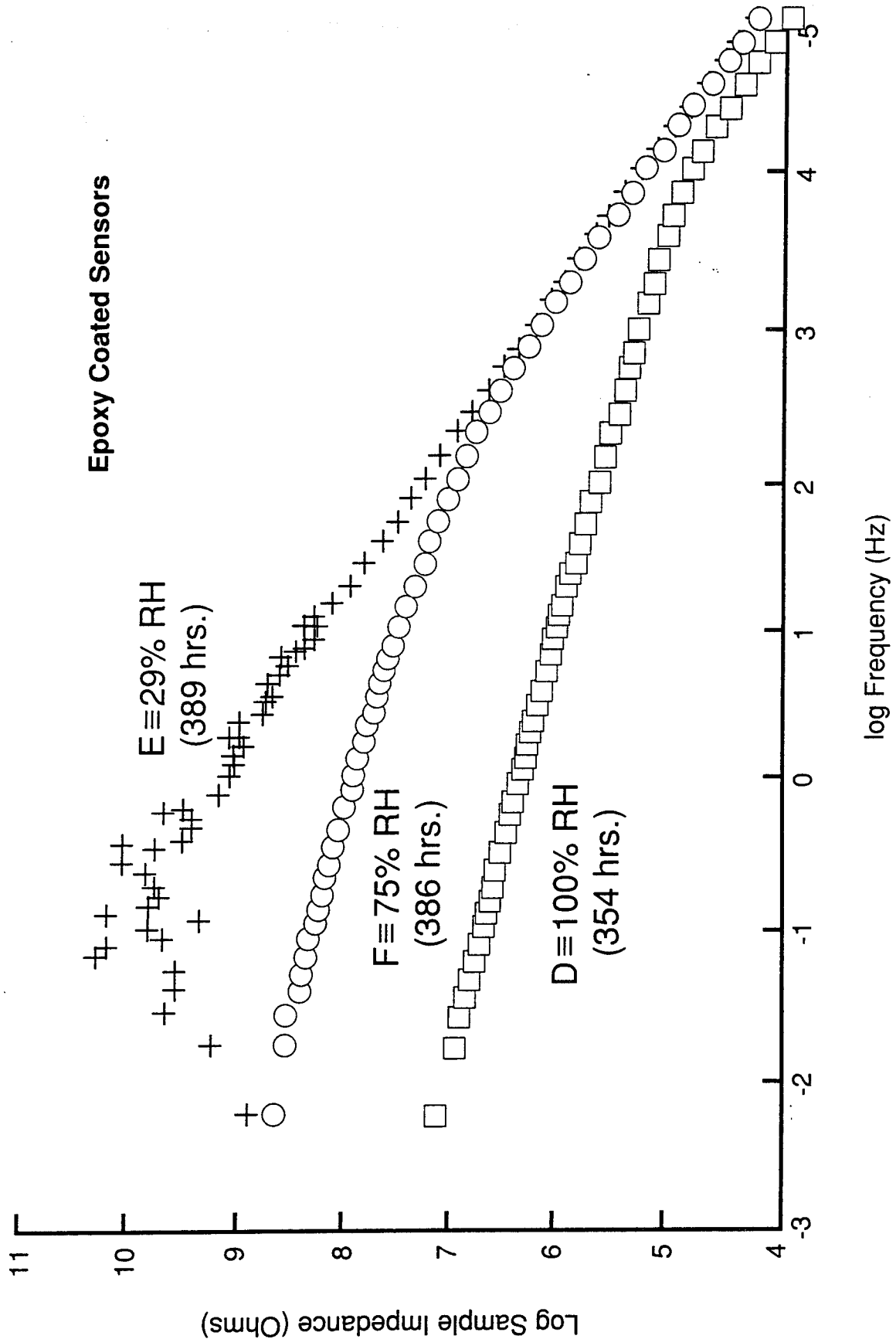

Figure 16. EIS bode magnitude response of epoxy coated sensors in 29, 75 or 100% relative humidity atmosphere.

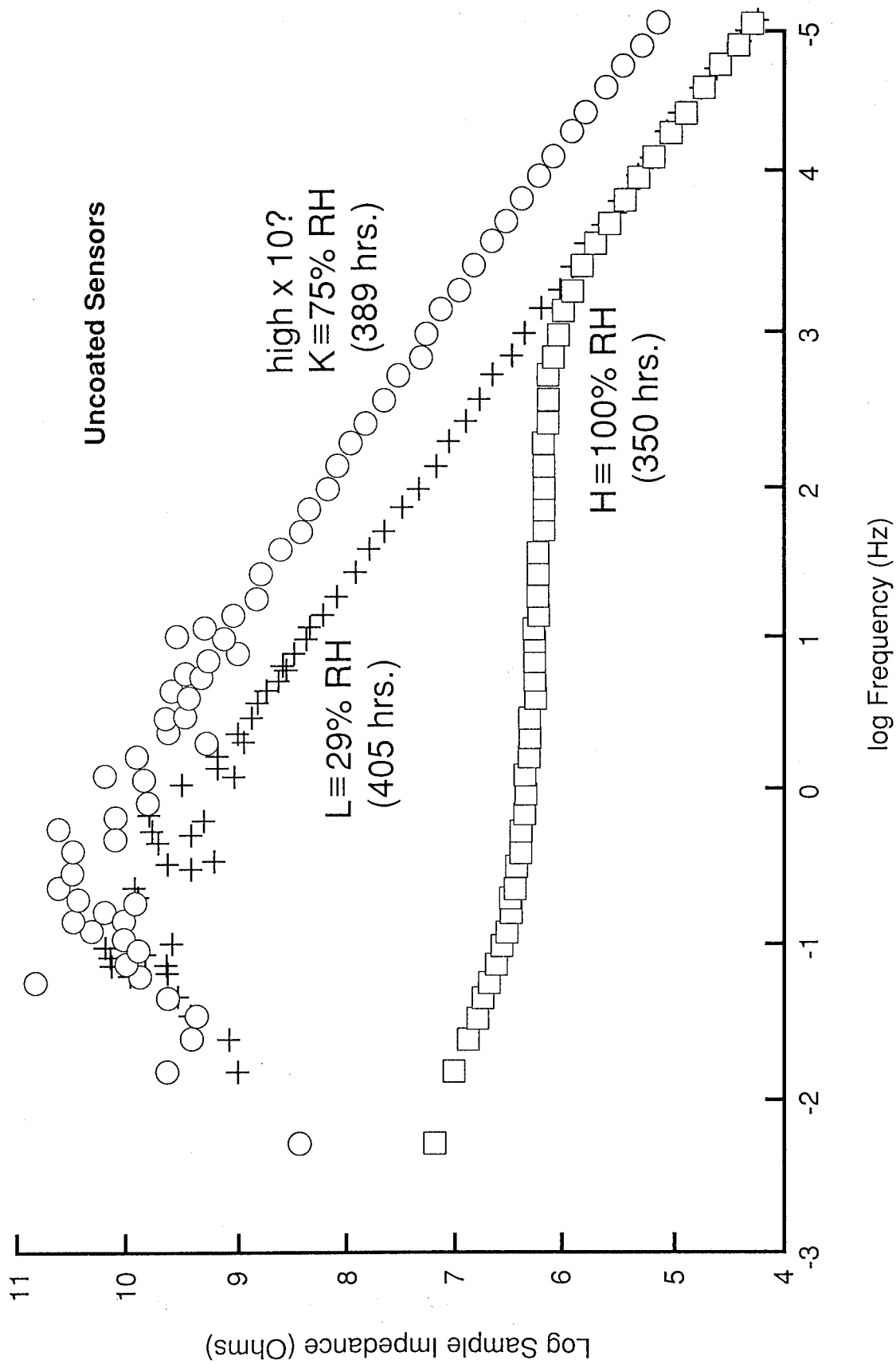

Figure 17. EIS bode magnitude response of uncoated sensors in 29, 75 or 100% relative humidity atmosphere.

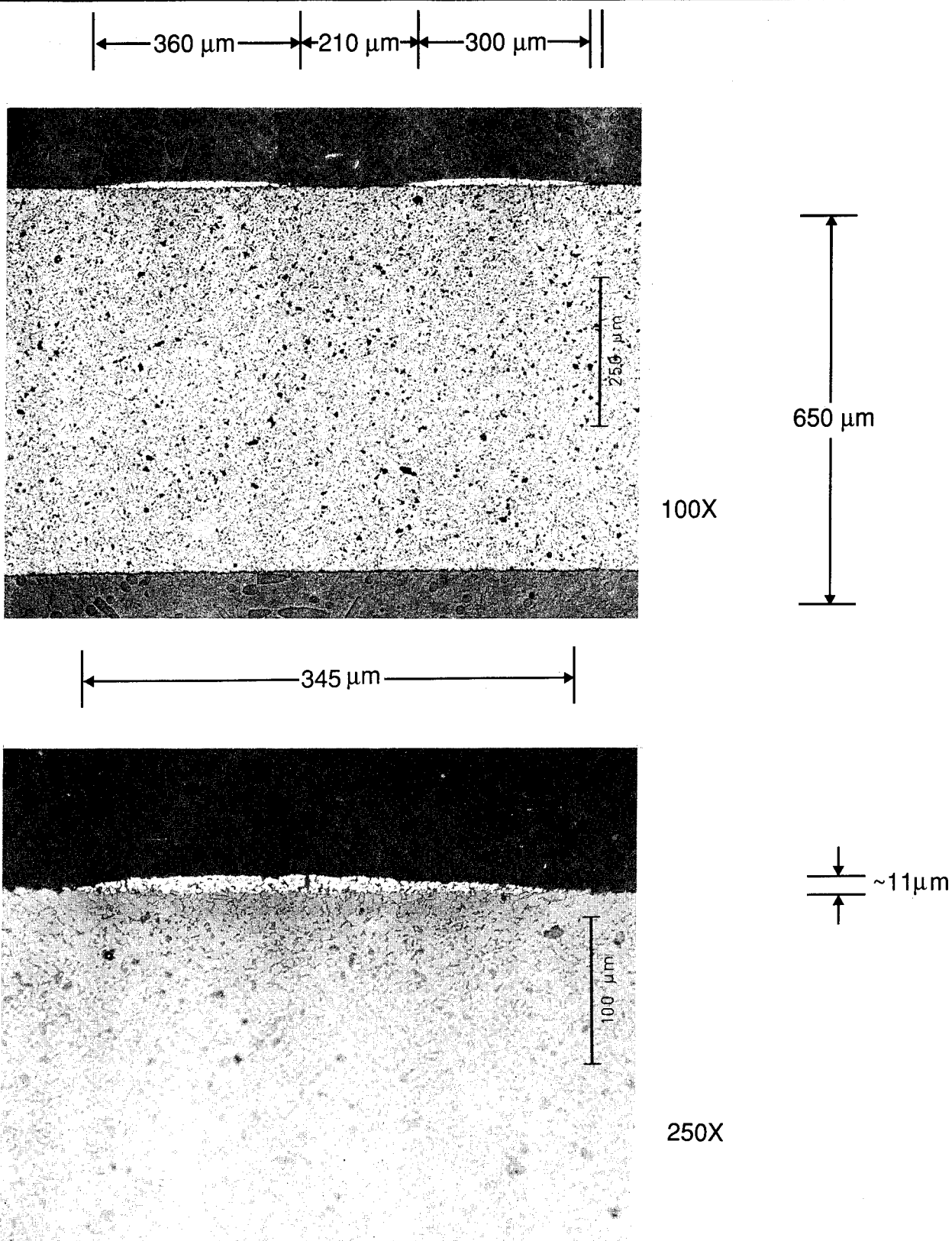

Figure 18. Cross-section view of uncoated sensor showing height and width of metal fingers on substrate.

The time dependency of the sensor responses also depended on the RH levels. The changes in the EIS response of the sensors in the 100% RH tank were initially quite rapid, the low frequency impedance dropping from $10^{10} \Omega$ to about $2 \times 10^7 \Omega$ within 16 hours of exposure (overnight). The epoxy coating seemed to absorb H_2O at a higher rate than the latex sensor. The low frequency impedances for all three sensors in the 100% RH tank slowly decreased with exposure time through 1,100 hours exposure as seen in Figure 19.

The samples in the 75% RH tank changed in the same general way without the initial rapid dropoff in the low frequency impedance. The Z_{max} values are presented in Figure 20 through 900 hours exposure. Both latex and epoxy coating capacitance values changed, the latex capacitance decreasing very slightly whereas the epoxy coating capacitance increased by the same small rate as the uncoated sensor. If one assumed the epoxy coating capacitance increase was due to water absorption into the epoxy coating, then the gain would be associated with an 0.6 w/o H_2O increase. Testing fully immersed, unfilled epoxy coatings previously showed an approximate increase of 3 w/o in the same exposure period.

The samples in the 29% RH tank have shown little change in the approximately 1,000 hours exposure. The Bode Magnitude data are summarized in Figure 21 and there is little difference between the three sensors. The time dependent Z_{max} values are summarized in Figure 22 and the behavior is similar to that seen for excellent coating systems in immersion experiments. The slight increase in both latex and epoxy coating capacitance values would correspond to an H_2O increase also of approximately 0.6 w/o. Although one might rationalize that the H_2O absorption is occurring on the sensor "backside" and within the alumina substrate and therefore should not affect the sensor coating impedance, there was no measurable increase in the capacitance values for the uncoated sensor in the same exposure period.

Sensors and EC Noise Testing outside Faraday Cage

Unlike the standard test panels discussed in the EC NOISE and DC RESISTANCE AND EIS Sections, the sensors were essentially segmented electrode systems with no true reference electrode measurement capability. Therefore the EC Noise set-up was limited to that of monitoring the current noise (I_n) as measured with the ZRA feature of the Gamry system. The voltmeter connections were made; however, the E_n values were consistently at 3.5 ± 0.5 mV outside the cage and 1.2 ± 0.2 mV inside the cage. The evaluation runs were limited to the sensors exposed to 100% and 29% RH with the samples equilibrated for approximately 1000 hours in the test tanks. The GGC measurements from the sensors outside the cage did not show any low frequency waves or any particular trends. Whereas the coated panel samples had areas of up to 400 cm^2 , these sensors had a coated and active overall area of 6.45 cm^2 area, possibly limiting the antenna capability. The I_n values for the two sets of sensors tested outside the Faraday cage are summarized in Table 5.

Table 5. Summary of I_n values from sensors outside cage in 100% and 29% RH conditions.

<u>Sensor Code</u>	<u>Coating</u>	<u>EIS Z_{max}</u> (Ohm)	<u>I_n Values. (Amp)</u>		
			<u>100% RH</u> (Amp)	<u>29% RH</u> (Amp)	<u>100%/29%</u>
A	Latex	6.3×10^6	1.6×10^{-12}	-	0.5
B	"	1.3×10^{10}	-	3.0×10^{-12}	
D	Epoxy	4.0×10^6	1.1×10^{-11}	-	14.7
E	"	2.7×10^{10}	-	7.5×10^{-13}	
H	Uncoated	2.2×10^7	1.7×10^{-12}	-	2.0
L	"	1.1×10^{10}	-	8.4×10^{-13}	

The tendency was for the drier sensors to show less current noise (I_n) than the sensors in the 100% RH tank. As can be seen in the table, there was no correspondence between the EIS maximum impedance values and I_n .

Therefore, the closely-spaced interdigitated sensor does allow meaningful electrochemical signals for monitoring the status of a double hull space. However, the sensor should be redesigned to include a reference electrode element therefore allowing the possibility of measuring E_n as well as I_n values.

Sensors and EC Noise Testing inside Faraday Cage

Placing the sensors within the Faraday cage had only a slight effect on the I_n values (~ 5% decrease) for the uncoated and epoxy coated sensors. The I_n values for the latex coated sensors were affected to a larger degree. Although the sensor elements were shorted through the ZRA connection, the E_n values for outside the cage averaged 3.5 mV for the six sensors, whereas inside the cage the average was 1.2 mV.

SUMMARY

The objectives of this project were:

- (1) Demonstrate if the EC Noise technique can determine the condition of organic barrier coating systems;
- (2) Demonstrate if the two electrode (sample area and reference electrode) EC Noise technique results in reasonable data relative to a three electrode (two sample areas and a reference electrode) set-up;
- (3) Demonstrate the usefulness of a coated, closely-spaced interdigitated detector as a corrosion sensor using EC Noise measurements and determining if E_n or I_n is more useful and comparing the behavior with that obtained using EIS;
- (4) Demonstrate whether the coated, closely-spaced interdigitated detector, as a corrosion sensor gives unique electrochemical signals at various relative humidities; and
- (5) Determine other relationships between EC Noise parameters and other electrochemical measurements.

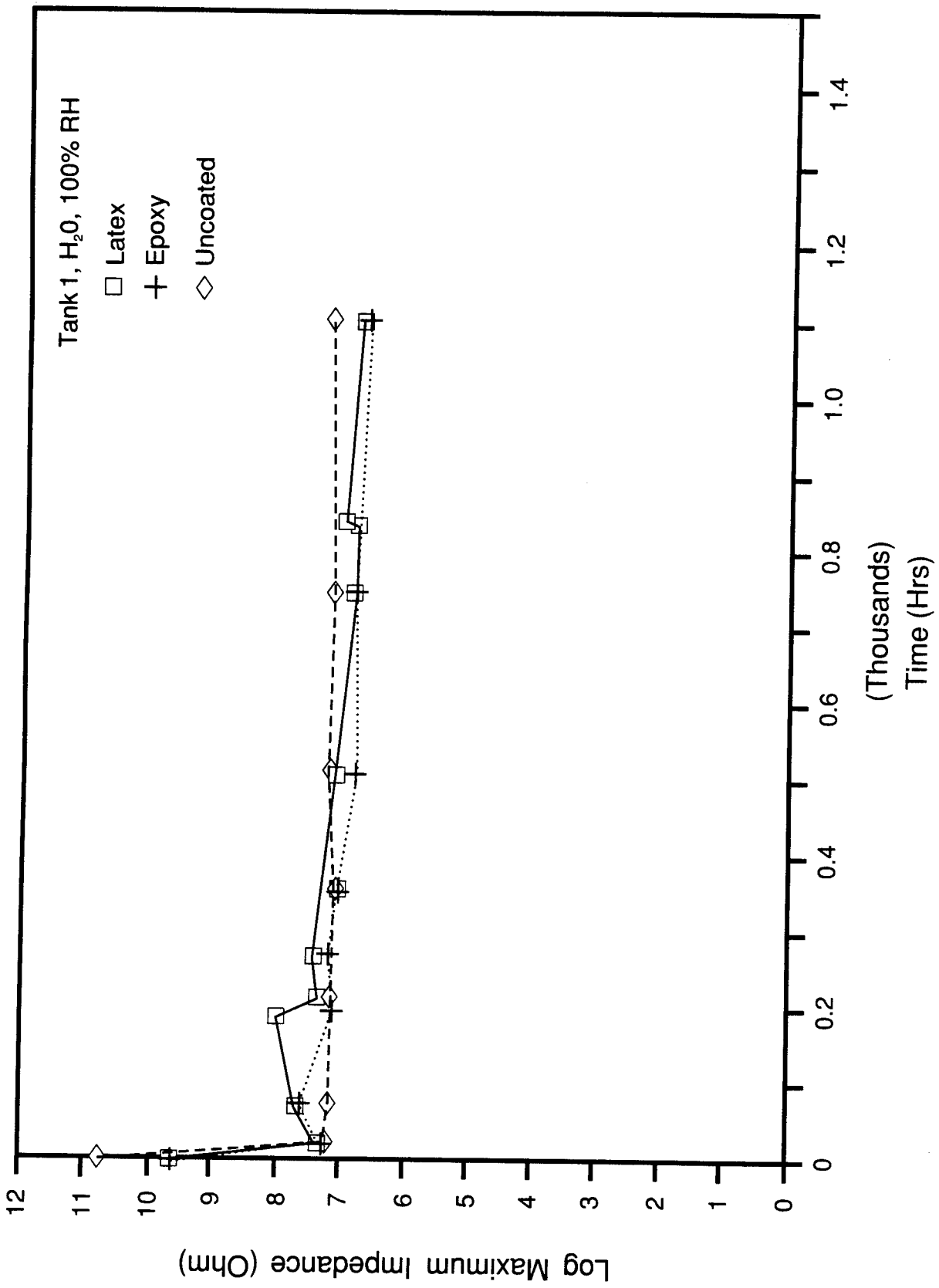

Figure 19. 100% RH, Z_{max} with time for uncoated, latex and epoxy coated sensors.

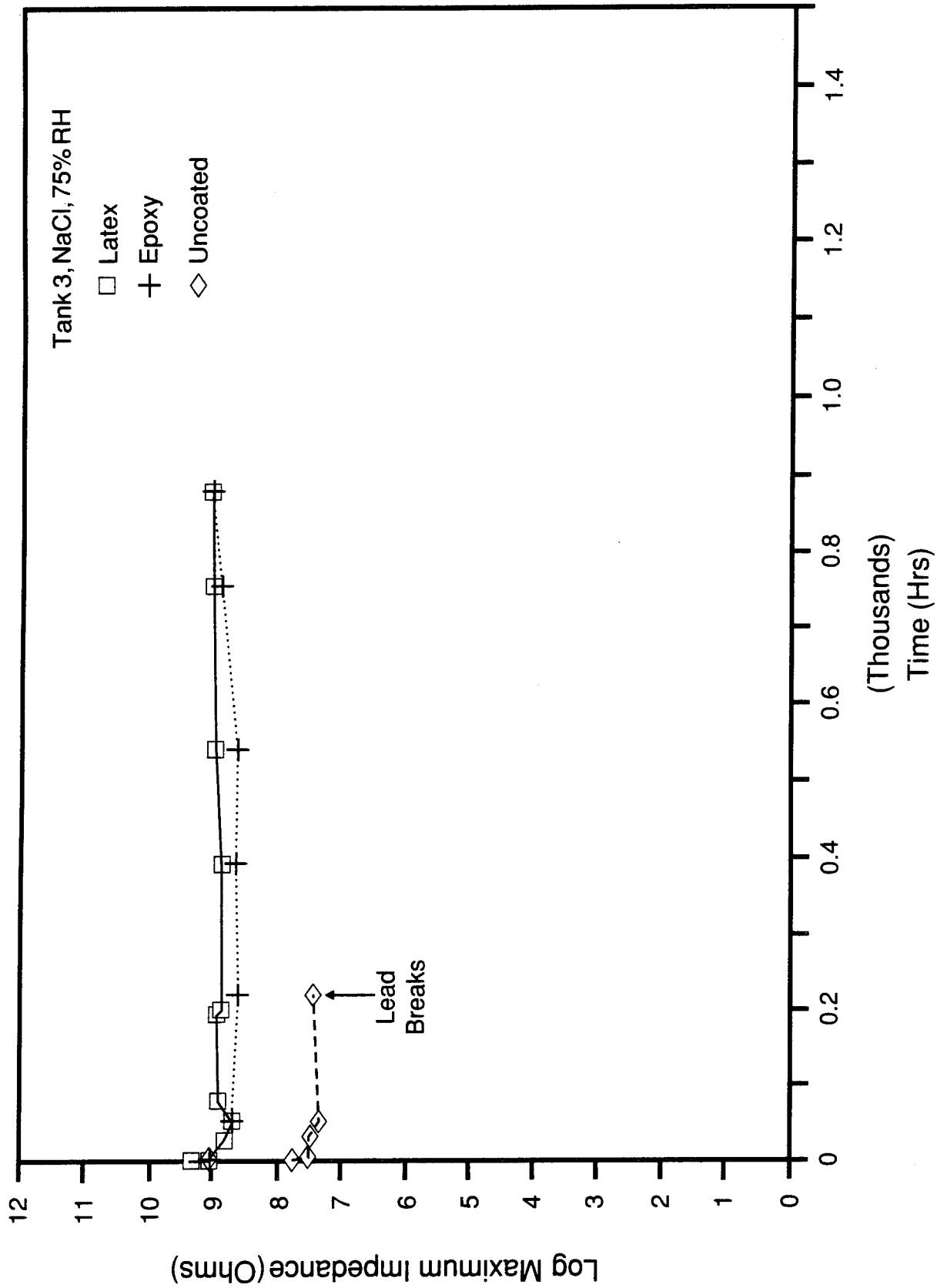

Figure 20. 75% RH, Z_{max} with time for uncoated, latex and epoxy coated sensors.

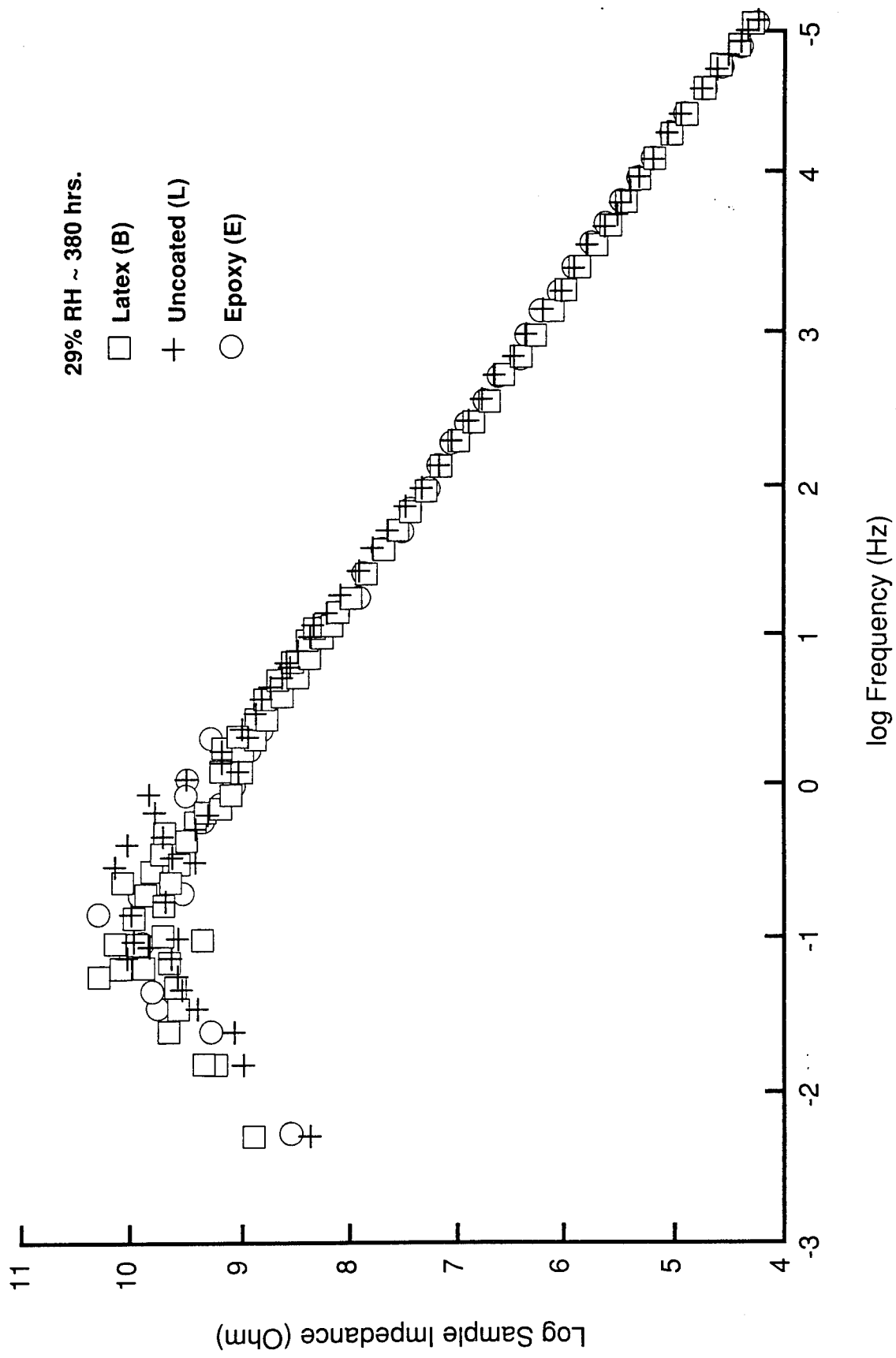

Figure 21. EIS bode magnitude response of uncoated, latex and epoxy coated sensors in 29% relative humidity atmosphere.

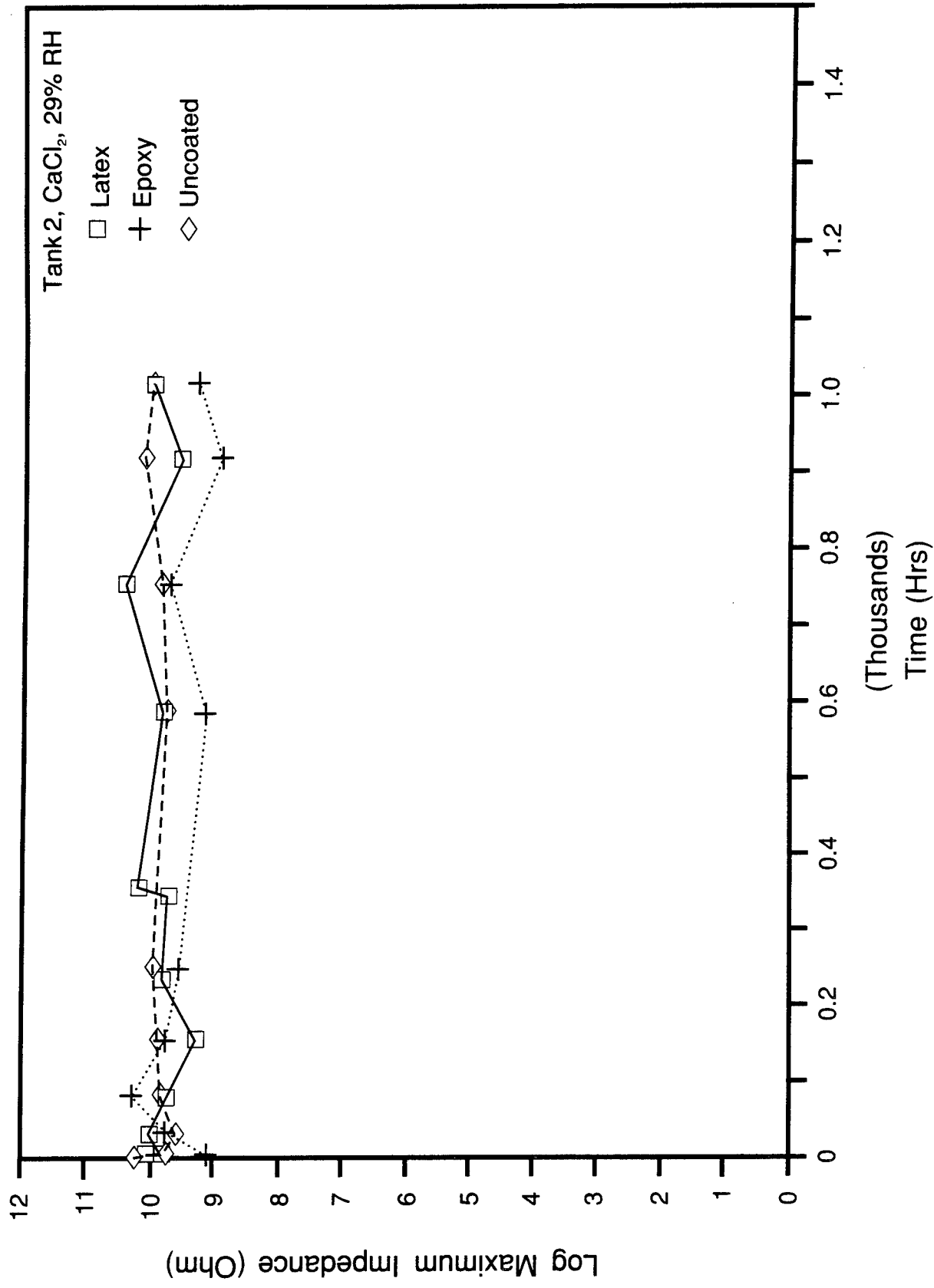

Figure 22. 29% RH, Z_{max} with time for uncoated, latex and epoxy coated sensors.

The possibility of using electrochemical voltage (E_n) and/or current (I_n) noise as a means for identifying the status of an organic barrier coating on steel was investigated experimentally. The intent was to demonstrate that this non-invasive approach provided a meaningful signal for the assessment of the status of coatings as had been suggested by Chen and Skerry¹. The classic EC Noise technique, which is normally applied to a segmented electrode or a pair of electrodes, had to be modified to approach the configuration(s) expected in the field. The modified approach involved evaluation of the coated sample E_n relative to a reference electrode, and an I_n signal which was limited by a blocking resistor to allow measurement of the E_n values. The evaluation included measurements of the noise from samples in a conventional test laboratory environment as well as from samples placed within a Faraday cage. These two conditions were intended to simulate external hull coating evaluations in a drydock and coating evaluations inside tanks and double-hull spaces. Seven different coating samples were selected from panels available from other CARDEROCKDIV, NSWV programs, the samples having been continuously exposed to aerated substitute ocean water for up to 4 years. In addition, the possibility of using coated, closely spaced, interdigitated electrode elements as corrosion sensors for double hull applications was also pursued.

As had been suggested by Chen and Skerry¹, a trend of increasing sample E_n values was demonstrated for coatings which have potentials suggesting greater corrosion protection. However, the amount of E_n signal was a function of the reference/counter electrode type, and was significantly reduced when the sample and leads were located within the Faraday cage. The largest E_n was measured when simply recording the sample potential at a 0.1 sec frequency for up to 400 sec, the limit of the particular data storage program. A low frequency voltage wave was documented for all samples tested outside the cage, the magnitude of this E_n wave not being measured by the Gamry Instruments' EC Noise approach. Presuming the high impedance coated samples and equipment leads are acting as antennas, the source of the observed low frequency wave (which changed for the different types of coatings) was not identified. However, at this point, one characteristic of a good coating might be that it allows accumulation of more local noise than attainable with a marginal or poor coating.

E_n data from the coated panel samples placed within the Faraday cage were small, up to 100 μ V. Although the trend was the same as with the samples tested outside the cage, whether this signal is sufficient for evaluations in the field requires verification.

Testing a latex and an epoxy coating on closely spaced, interdigitated silver electrodes as corrosion sensors in different relative humidity atmospheres using EIS was reasonably successful. However, the results from EC Noise measurements limited to I_n were conflicting. I_n was higher for the epoxy coating and the uncoated sensor at the 100% RH condition but somewhat lower for the latex coated sensor. Possibly the limitation here was the interaction of the coating and the moisture with the silver fingers. A more consistent I_n signal should result from an Fe or steel/coating interface. The EIS experiments demonstrated that a shift in characteristics occurred and could be related to the relative humidity in the test environment. The trends suggested changes could be detected at relative humidities as low as 50%. In that atmospheric corrosion rates become minimal at $\leq 50\%$ RH, the coated interdigitated sensor, modified to include a reference electrode element, would appear to be directly applicable for the corrosion monitoring of double hull interior spaces.

CONCLUSIONS

The majority of the project objectives were met and the following conclusions can be drawn.

- The classic EC Noise technique can be successfully modified for evaluating organic barrier coatings in the configurations expected for normal Navy hull and tank/void applications.
- Assuming that the potential of an organic barrier coated panel is a reasonable measure of the state of coating protection, a direct relationship was shown between the electrochemical potential noise (E_n) values and the coating potentials relative to a reference electrode.
- The E_n signal was affected somewhat by the selected reference electrode (zinc vs Ag/AgCl). The signals from samples tested in a conventional laboratory environment were a combination of true sample electrochemical noise and an electrical signal gathered by the sample and the lead wires acting as an antenna.
- The Gamry E_n data collection approach avoids the collection of the low frequency waves that were shown to be present using other data gathering techniques, and the Gamry E_n program therefore reports roughly half of the total E_n signal.
- The antenna effect also appears to be affected by the quality of the coating(s), a greater effect observed for the better coatings. Therefore, although the E_n wave values are not direct measures of the coated panel corrosion process, E_n wave is the largest signal available and can be correlated with the coating status.
- The E_n values from samples evaluated within a Faraday cage were significantly reduced to roughly the 100 μ V level but still followed the same trend on increasing E_n with respect to the sample potentials. Shipyard evaluations of ballast and/or CHT tank coatings will be necessary to determine if there is sufficient signal for evaluating the coating status.
- The two electrode approach for large coated surfaces can result in useful data for the evaluation of the status of a ship coating. However, a segmented electrode or the classic three electrode EC Noise set-up would probably be preferable for evaluating coatings in the laboratory.
- The coated, closely spaced interdigitated sensor was shown to respond electrochemically to the presence of moisture in atmospheric environments of 75% RH or higher. The behavior of the epoxy coated sensor was successfully monitored using EIS. Sensor design modifications which would include a reference element would be necessary to employ the sensor more advantageously in EC Noise measurements.

PROPOSED AREAS FOR ADDITIONAL WORK

The depth and scope of this investigation was limited by the time and funding constraints. Additional data from new and "good" coatings is required for a better assessment of the extent of the E_n values and a determination of the extent of non-linearity of E_n vs E_{corr} . The question of the extent of shipyard electrical noise that will be included in hull measurements and within inboard tankages also needs to be resolved. Additionally, as the coated interdigitated sensor has been shown to have applicability in the assessment of corrosion conditions within an enclosed tank, verification of a successful redesign of the sensor into a three electrode device is required.

In consideration of the foregoing comments, the following additional areas of work are proposed:

- A statistically valid data base consisting of the EC Noise and related electrochemical signal (E_{corr} , EIS, DC resistance) parameters for well cured as well as newly prepared MIL-P-24441, Type 1 and Type 4 coatings should be determined and monitored for a minimum of 6 months.
- The EC Noise and E_{corr} characteristics of a ship hull and interior tankage coating systems should be evaluated in a shipyard environment to determine if the laboratory based signals are at least maintained. Laboratory-evaluated test panel evaluation within the shipyard environment should be included as part of the testing.
- Coated test pieces of a three electrode redesigned, closely spaced interdigitated sensor element should be evaluated using EC Noise and related electrochemical test approaches under various RH conditions. Moisture absorption rate data should also be determined independently. Additionally, coated test pieces should be evaluated under local outdoor conditions to determine if coating degradation in a conventional atmosphere can be studied by the EC Noise and/or related electrochemical techniques.

REFERENCES

1. Chen, C-T and B.S. Skerry; "Assessing the Corrosion Resistance of Painted Steel by AC Impedance and Electrochemical Noise Techniques", *Corrosion*, 47, No. 8, pp. 598-611 (Aug 1991).
2. Bertocci, U. and J. Kruger; "Studies of Passive Film Breakdown by Detection and Analysis of Electrochemical Noise", *Surf. Sci.*, 101, pp. 608-618 (1980).
3. Iverson, W.P.; "Transient Voltage Changes Produced in Corroding Metals and Alloys, *J. Electrochem. Soc.*, 115, No. 6, pp. 617-618 (Jun 1968).
4. Hladky, K.; "E/ Corrosion Monitoring", U.S. Patent 4,575, 678 (11 Mar 1986).
5. Eden, D.A., M. Hoffman and B.S. Skerry; "Polymeric Materials for Corrosion Control", ACS Symposium Series, Vol. 322, pp. 36-47, ACS (1986).
6. Stern, M. and A.L. Geary; "Electrochemical Polarization I, A Theoretical Analysis of the Shape of Polarization Curves", *J. Electrochem. Soc.*, 104, No. 1, pp. 56-63 (Jan 1957).
7. Mansfeld, F., S.L. Jeanjaquet and M.W. Kendig; "An Electrochemical Impedance Spectroscopy Study of Reactions at the Metal/Coating Interface", *Corr. Sci.*, 26, No. 9, pp. 735-742 (1986).
8. Simpson, T., P.J. Moran, H. Hampel, G.D. Davis, B.A. Shaw, C.O. Arah, T.L. Fritz and K. Zankel; "Electrochemical Monitoring of Organic Coating Degradation During Atmospheric or Vapor Phase Exposure", *Corrosion*, 46, No. 4, pp. 331-336 (Apr 1990).
9. Murray, J.N. and H.P. Hack; "Evaluation of Architectural and Immersion Coatings Using Electrochemical Impedance Spectroscopy, (EIS)", Proceedings of the Tri-Service Conference on Corrosion, ed. M. Levy, pp 287-297, Plymouth, MA (12-14 May 1992).
10. Kranbuehl, D. and T. Hamilton; "An Automated Instrumental Technique for Measuring the Processing Properties and State of Cure of Polymer Coatings-Paints" (Proprietary) Contract Final Report to Newport News Shipbuilding Company (15 July 1989).
11. Kendig, M.W. and H. Leidheiser; "The Electrical Properties of Protective Polymer Coatings as Related to Corrosion of the Substrate", *JECS*, 123, No. 7, pp. 982-989 (Jul 1976).
12. Brown, M.D; "Laboratory and Field Tests for Coatings That Make Sense in the Real World", *Mat. Perf.*, 33, No. 8, pp. 30-34 (Aug 1994).
13. Bacon, R.C., J.J. Smith and F.M. Rugg; "Electrolytic Resistance in Evaluating Protective Merit of Coatings on Metals", *I&EC*, 40, No. 1, pp. 161-167 (Jan 1948).
14. Diamond, E.L.; CDNSWC Code 643, Private communications (1992-1993).

-
15. Murray, J.N. and H.P. Hack; "Testing Organic Architectural Coatings in ASTM Sea Water Using E.I.S.", *Corrosion*, 48, No. 8, pp. 671-685 (Aug 1992).
 16. Murray, J.N.; "Evaluation of Thick Cast Polyurethane Coatings on Steel Using EIS and DC Electrochemical Techniques", *Proceedings of 2nd. International Conference, Advances in Corrosion Protection by Organic Coatings*, Cambridge, UK (12-16 Sep 1994).

INITIAL DISTRIBUTION

Copies		Eng. Science & Mechanics University Park PA 16802
3	ONR	
1	334 (Gagorik)	1 Prof. Florian Mansfeld
1	332 (Sedriks)	University of Southern California
2	NAVSEA	Dept of Materials Science VJE714
1	SEA 03M (Kaznoff)	Los Angeles CA 90089
1	SEA 03M (Holmes)	1 Prof. Patrick J. Moran
1	NRL	U.S. Naval Academy
	Code 6130 (Thomas)	Dept of Mechanical Engr
1	NRL Key West	Richover Hall
2	DTIC	Annapolis MD 21402
1	U.S. Army Natick RD&E Center	1 Mr. Robert S. Rodgers
	STRNC-WTS (Dittmeier)	EG&G Princeton Applied Re-
	Natick MA	search
1	U.S. Army Research Laboratory	P.O. Box 2565
	Material Command (Beatty)	Princeton NJ 08543
	Johns Hopkins Univ.	1 Dr. Brian S. Skerry
	Maryland Hall (102)	Sherman-Williams Co.
	Baltimore MD 21218	Consumer Division Tech Center
1	Prof. Gordon Bierwagen	601 Canal Road
	N. Dakota State University	Cleveland OH 44113
	Dept of Polymers & Coatings	1 Dr. W. Stephen Tait
	Fargo ND 58105	S.C. Johnson & Co., Inc.
1	Dr. Richard D. Granata	1525 Howe St
	Lehigh University	Racine WS 53403
	Sinclair Lab, Bldg 7	1 Mr. Max R. Yaffe
	Bethlehem PA 43573	Gamry Instruments, Inc.
1	Dr. Martin W. Kendig	670-C1 Easton Road
	Rockwell International	Willow Grove PA 19090
	P.O. Box 1085	1 Prof. Richard Brown
	Thousand Oaks CA 91360	Univ of Rhode Island
1	Prof. D.D. MacDonald	Dept of Chemical Engr
	Penn State University	Kingston RI

		CENTER DISTRIBUTION		
		Copies	Code	Name
1	Prof. Mark E. Orazem			
	University of Florida			
	Dept of Chemical Engr	1	011	
	Gainesville FL 32611	1	0113	
		1	0114	
1	Dr. David C. Silverman	1	0115	Caplan
	Monsanto Chemical Co.	1	1240	Gallagher
		1	60	
	800 N. Lindbergh Blvd	1	601	Ventriglio
	St. Louis MO 63167	1	602	Morton
		1	603	Cavallaro
1	Solartron Instruments	1	603	Hardy
		1	61	
	11321 Richmond Ave	1	61S	
	Suite M102	1	612	
	Houston TX 77082	5	613	
		2	613	Hack
1	Prof. S. Raymond Taylor	2	613	Murray
		1	61	
	University of Virginia	1	615	
	Dept of Matls Science & Engr	2	624	
	Thorton Hall	1	624.1	Clayton
		1	6244	Steck
	Charlottesville VA 22901	1	63	
		1	64	
1	Dr. Jonathan W. Martin	2	641	
	Naval Inst for Science & Tech	1	641	Bohlander
		1	66	
	Building Materials	2	66.1	Melton
	Bldg 226, Rm B-348	5	68	
		1	683	Barnes
	Gaithersburg MD 20899	1	322.2	

REPORT DOCUMENTATION PAGE

Form Approved
OMB No. 0704-0188

Public reporting burden for this collection of information is estimated to average 1 hour per response, including the time for reviewing instructions, searching existing data sources, gathering and maintaining the data needed, and completing and reviewing the collection of information. Send comments regarding this burden estimate or any other aspect of this collection of information, including suggestions for reducing this burden, to Washington Headquarters Services, Directorate for Information Operations and Reports, 1215 Jefferson Davis Highway, Suite 1204, Arlington, VA 22202-4302, and to the Office of Management and Budget, Paperwork Reduction Project (0704-0188), Washington, DC 20503.

1. AGENCY USE ONLY (Leave blank)		2. REPORT DATE August 1994		3. REPORT TYPE AND DATES COVERED Research & Development—FY 1994	
4. TITLE AND SUBTITLE Evaluation of Electrochemical Noise to Monitor Corrosion for Double Hull Applications				5. FUNDING NUMBERS	
6. AUTHOR(S) John N. Murray					
7. PERFORMING ORGANIZATION NAME(S) AND ADDRESS(ES) Carderock Division, Naval Surface Warfare Center Code 613, Marine Corrosion Branch 3A Leggett Circle Annapolis MD 21402-5067				8. PERFORMING ORGANIZATION REPORT NUMBER CARDIVNSWC-TR-61-94/29	
9. SPONSORING / MONITORING AGENCY NAME(S) AND ADDRESS(ES) Carderock Division Naval Surface Warfare Center Bethesda MD 20084-5000				10. SPONSORING / MONITORING AGENCY REPORT NUMBER	
11. SUPPLEMENTARY NOTES					
12a. DISTRIBUTION / AVAILABILITY STATEMENT Approved for public release; distribution is unlimited.				12b. DISTRIBUTION CODE	
<p>13. ABSTRACT (Maximum 200 words)</p> <p>The use of electrochemical noise (EC noise) as a non-destructive evaluation (NDE) method for characterizing the status of organic barrier coated steel surfaces was evaluated in the laboratory for possible application to Navy double-hull applications. External hull and internal tankage/space conditions were simulated by evaluating previously aged samples outside and inside a Faraday cage. The voltage noise (E_n) signal was shown to be considerably larger when measured outside the cage and the same general result of higher noise signals from "better" coatings was observed for both conditions. Measurements of the sample noise outside the cage include both coating/substrate interfacial electrochemical noise and local stray electrical effects as the high impedance coating systems act as an antenna. Although the particular commercial E_n data gathering program was found to collect less of the total E_n signal for samples outside the cage because of a limitation in intermediate data storage, the signal was sufficient for laboratory evaluations. The usefulness of evaluations of hull surfaces while in industrial drydock conditions remains to be established.</p> <p>Latex and epoxy coated electrochemical sensors were also evaluated for applicability in non-immersion situations such as the interior double-hull spaces. Although the EC Noise data were limited, electrochemical impedance spectroscopy data showed the sensors to respond in 75 and 100% relative humidity (RH) atmospheres but only to a limited degree in 29% RH.</p>					
14. SUBJECT TERMS Electrochemical noise; Organic barrier coatings; Corrosion monitoring; Double hull ships; Corrosion sensors				15. NUMBER OF PAGES 43	
				16. PRICE CODE	
17. SECURITY CLASSIFICATION OF REPORT UNCLASSIFIED	18. SECURITY CLASSIFICATION OF THIS PAGE UNCLASSIFIED	19. SECURITY CLASSIFICATION OF ABSTRACT UNCLASSIFIED	20. LIMITATION OF ABSTRACT SAME AS REPORT		