

LINEAR MOTOR FREE PISTON COMPRESSOR

Final Report

David P. Bloomfield
February 17, 1995

DTIC
ELECTE
MAR 14 1995
S G D

U.S. ARMY RESEARCH OFFICE

REFERENCE: P-30443-CH-S
Contract No.: DAAL03-92-C-0016
Completed on: December 31, 1994

*Analytic Power Corp.
268 Summer Street
Boston, MA 02210
617-542-6352 (Voice)
617-695-3272 (FAX)*

APPROVED FOR PUBLIC RELEASE;
DISTRIBUTION UNLIMITED

19950308 042

REPORT DOCUMENTATION PAGE			Form Approved OMB No. 0704-0188
Public reporting burden for this collection of information is estimated to average 1 hour per response, including the time for reviewing instructions, searching existing data sources, gathering and maintaining the data needed, and completing and reviewing the collection of information. Send comments regarding this burden estimate or any other aspect of this collection of information, including suggestions for reducing this burden, to Washington Headquarters Services, Directorate for Information Operations and Reports, 1215 Jefferson Davis Highway, Suite 1204, Arlington, VA 22202-4302, and to the Office of Management and Budget, Paperwork Reduction Project (0704-0188), Washington, DC 20503.			
1. AGENCY USE ONLY (Leave blank)	2. REPORT DATE 1995	3. REPORT TYPE AND DATES COVERED Final Report	
4. TITLE AND SUBTITLE Linear Motor Free Piston Compressor		5. FUNDING NUMBERS DAAL03-C-92-C-0016	
6. AUTHOR(S) David P. Bloomfield			
7. PERFORMING ORGANIZATION NAME(S) AND ADDRESS(ES) Analytic Power Corp. 268 Summer Street Boston, MA 02210		8. PERFORMING ORGANIZATION REPORT NUMBER	
9. SPONSORING / MONITORING AGENCY NAME(S) AND ADDRESS(ES) U. S. Army Research Office P. O. Box 12211 Research Triangle Park, NC 27709-2211		10. SPONSORING / MONITORING AGENCY REPORT NUMBER AR6 30443.1-C#5	
11. SUPPLEMENTARY NOTES The view, opinions and/or findings contained in this report are those of the author(s) and should not be construed as an official Department of the Army position, policy, or decision, unless so designated by other documentation.			
12a. DISTRIBUTION / AVAILABILITY STATEMENT Approved for public release; distribution unlimited.		12b. DISTRIBUTION CODE	
13. ABSTRACT (Maximum 200 words) A Linear Motor Free Piston Compressor (LMFPC), a free piston pressure recovery system for fuel cell power plants, was developed. The LMFPC consists of a reciprocating compressor and a reciprocating expander which are separated by a piston. In the past, energy efficient turbochargers have been used for pressurizing large (over 50 kW) fuel cell power plants by recovering pressure energy from the powerplant exhaust. A free piston compressor allows pressurizing 3 - 5 kW sized fuel cell powerplants. The motivation for pressurizing PEM fuel cell power plants is to improve fuel cell performance. Pressurization of direct methanol fuel cells will be required if PEM membranes are to be used. Direct methanol oxidaztion anode catalysts require high temperatures to operate at reasonable power densities. The elevated temperatures, above 80°C, will cause high water loss from conventional PEM membranes unless pressurization is employed. Because pressurization is an energy intensive process, recovery of the pressure energy is required to permit high efficiency in fuel cell power plants. A complete LMFPC which can pressurize a 3 kW fuel cell stack was built. This unit is one of several that were constructed during the course of the program.			
14. SUBJECT TERMS fuel cell, pressurization, linear motor free piston compressor		15. NUMBER OF PAGES 30	16. PRICE CODE
17. SECURITY CLASSIFICATION OF REPORT UNCLASSIFIED	18. SECURITY CLASSIFICATION OF THIS PAGE UNCLASSIFIED	19. SECURITY CLASSIFICATION OF ABSTRACT UNCLASSIFIED	20. LIMITATION OF ABSTRACT UL

INTRODUCTION	1
SUMMARY	2
Fuel Cell Performance	2
Membrane Resistance and Water Vapor Pressure	2
Performance and Pressure	3
System Effects	3
<u>System Weight & Volume</u>	4
<u>Water Recovery</u>	4
Pressure Recovery and Efficiency	5
Comparing Pressurized and Ambient Systems	6
PRESSURIZATION METHODS	8
Linear Motor Free Piston Compressors	8
Pressure Recovery in Fuel Cell Power Plants	8
Pressure Recovery with a Free Piston Engine	8
LMFPC Alternatives	10
Turbocharging	10
Size and Flow Rate	10
Turbocharger Efficiency	10
Starting and Load Following	11
RESULTS	12
Free Piston Machines	12
Expanders	12
Expander Valves	12
Compressors	13
Non lubricated compressor seals	14
Compressor valves	14
Linear Motor	15
High Efficiency Linear Motor	15
Magnetics & Operating Characteristics	15
Linear Motor Bearings	17

Power Circuit 17

Controlling the Linear Motor 18

 Background 18

 Phase Locked Controller 18

 Aura Systems 19

 Fuzzy Logic Controller 20

 Non Linear Characteristics of the System 20

 Software 22

 Controller 22

 Independent Parameters 22

 Output Signals 22

 Signal Processing 22

 Valve Actuation 24

 Status 24

RECOMMENDATIONS 24

 Linear Motor Optimization 24

 Placement of Compressor/Expander 25

 Testing and Further Development 25

SCIENTIFIC PERSONNEL INVOLVED 26

PUBLICATIONS 26

Accession For	
NTIS CRA&I	<input checked="" type="checkbox"/>
DTIC TAB	<input type="checkbox"/>
Unannounced	<input type="checkbox"/>
Justification	
By	
Distribution /	
Availability Codes	
Dist	Avail and/or Special
A-1	

LINEAR MOTOR FREE PISTON COMPRESSOR PROGRAM

INTRODUCTION

The purpose of this program was to develop a free piston pressure recovery system for fuel cell power plants. We developed a Linear Motor Free Piston Compressor (LMFPC). The LMFPC consists of a reciprocating compressor and a reciprocating expander which are separated by a piston. The piston is connected to the actuator of a solenoid by a solid rod. Alternatively, the solenoid may be placed between the two pistons, connected by a solid rod which also holds the permanent magnet of the solenoid.

In the past, energy efficient turbochargers have been used for pressurizing large (over 50 kW) fuel cell power plants by recovering pressure energy from the powerplant exhaust. A free piston compressor allows pressurizing 3 - 5 kW sized fuel cell powerplants. The motivation for pressurizing PEM fuel cell power plants is to improve fuel cell performance. Pressurization of direct methanol fuel cells will be required if PEM membranes are to be used. Direct methanol oxidization anode catalysts require high temperatures to operate at reasonable power densities. The elevated temperatures, above 80°C, will cause high water loss from conventional PEM membranes unless pressurization is employed. Because pressurization is an energy intensive process, recovery of the pressure energy is required to permit high efficiency in fuel cell power plants. In this report we show that pressurizing a fuel cell to 3.4 atm (abs) at an air utilization of 60% requires about 18% of the power developed by the cell stack.

During this program we addressed and resolved several problems that are crucial to the success of the LMFPC. These were: identifying a high force solenoid (linear motor) and high speed expander inlet solenoid valves, and development of a control system. We also resolved lesser issues such as identifying cylinder seal materials and compressor valves. After spending about a year trying to design and construct our own linear motor, we found a commercially available solenoid that is made by Aura Systems. We identified solenoid valves made by General Valve Corp. which are adequate for the task.

Developing a control system was the most difficult part of the project. After using and discarding several control systems that were based on harmonic motion, we developed our own fuzzy logic controller to drive an H circuit specially built by Analytic Power.

In the final portion of the program we developed a simple systems analysis which identifies the important aspects of an LMFPC. It shows why compressors without expanders are not relevant to hydrogen/air fuel cells, although they may have relevance to direct methanol oxidation systems since it is doubtful that any PEM based methanol system will be able to operate without a compressor.

A complete LMFPC which can pressurize a 3 kW fuel cell stack was built. It has not completed its testing and has not yet delivered pressurized gas. This unit is one of several that were constructed during the course of the program. The unit is shown in Figure 1.

SUMMARY

Fuel Cell Performance

At the start of this program, increasing the pressure of a hydrogen/air PEM fuel cell stack to 3.5 atm. caused an increase in current density from 100 ASF to 1000 ASF for a constant cell voltage. During the course of this program significant advances in membranes have taken place. With todays improved membranes, we only see a three to four fold increase in performance.

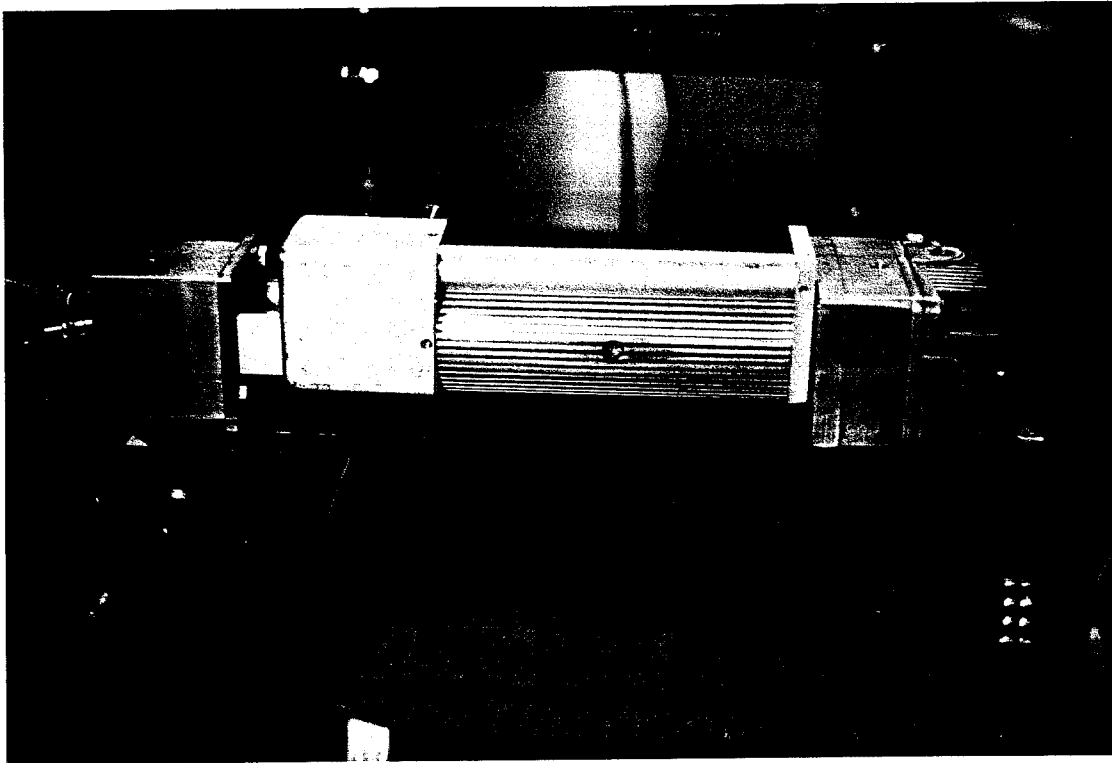

Figure 1 Linear Motor Free Piston Compressor

Performance increases are attributable to three fuel cell performance factors: catalyst activity, membrane resistance, and thermodynamic effects. Increasing the pressure of a PEM fuel cell stack by a factor of four permits the stack to operate at an elevated temperature near 200 degrees Fahrenheit. The equilibrium water vapor pressure of the cell is increased and the cell membrane absorbs more water. The increased temperature and reactant partial pressure improve the performance from a Nernst or thermodynamic standpoint. The higher temperature and pressure improve the catalyst activity. The increase in membrane water content drops the membrane resistance.

Membrane Resistance and Water Vapor Pressure

The operating temperature of fuel cells is controlled by humidification of the membrane. Membrane resistance is a function of its water content. The equilibrium vapor pressure of water above a Nafion membrane is the same as above pure water. Increasing the cell temperature so that

the vapor pressure exceeds the total pressure will cause the membrane to dry out. This is why PEM fuel cells operating at 1 atm. are restricted to operating near room temperature. There is no vapor pressure suppression by the presence of the electrolyte. Increasing the total pressure allows an increase of the water vapor partial pressure. Operation at high pressure allows us to increase the cell temperature.

When the standard of performance was Nafion 117 membrane or 5 mil thick Dow membrane, membrane resistance was a limiting factor. Analytic Power's standard membrane is a 2 mil thick Nafion 112F. We have tested 0.75 mils thick (19 microns) membrane (see the performance data in Figure 2) and we will soon test membrane which is 10 microns thick. Very thin membranes enhance water transport from cathode to anode, reducing anode dryout at high current density operation. Thus membrane resistance is a decreasing consideration in modern hydrogen/air PEM fuel cells. This means that less importance will be attached to building power plants which can maximize the amount of water in the membrane using pressurization.

Performance and Pressure

Increasing fuel cell temperature and pressure dramatically affects its performance. The performance data in Figure 2 shows that the current density of cells operating on hydrogen and air at 0.7 volts per cell will rise from about 250 ASF to between 750 and 1000 ASF. The performance is relatively flat in this region so that a small change in cell volts can yield a very large change in current density. Clearly, the current density at high pressure is 3 to 4 times that at low pressure.

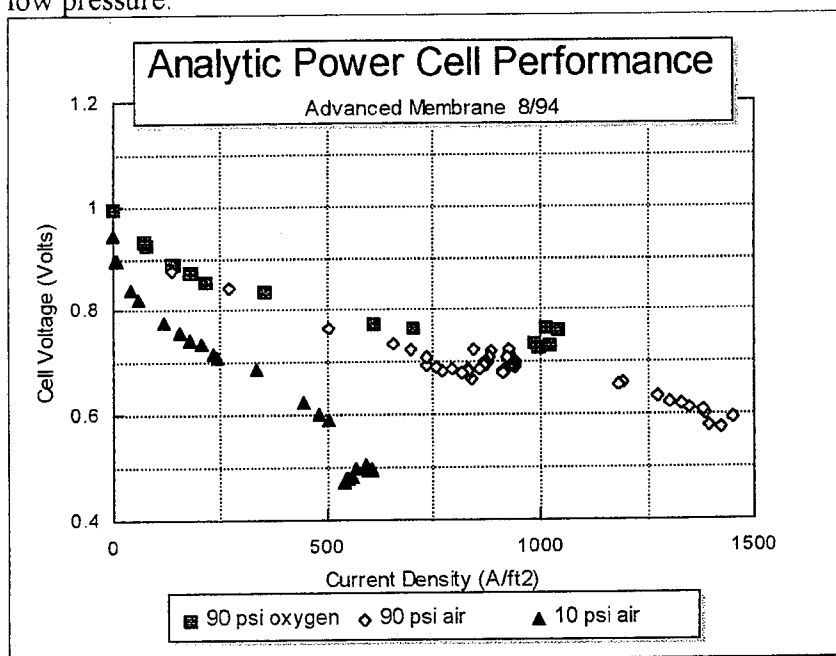

Figure 2 Advanced Fuel Cell Performance

same power density as an ambient pressure fuel cell stack and must be 18% larger to generate the additional power for the compressor. The advantage of high pressure operation is more than offset by the power requirements of the compressor. The LMFPFC pressurized system operates at twice the power density of the ambient fuel cell stack. The power increase required by the

System Effects

Analytic Power conducted a systems study to determine the effect of pressurizing a fuel cell power plant on its weight and volume. The purpose of the study was to identify the performance parameters associated with pressurization equipment which would have a significant impact on the performance of the power plant. The conclusion of the study is that the motor driven compressor provides no power plant advantage in that it requires a fuel cell stack which operates at the

LMFPC pressurized system is only 11% more than the ambient system. The high pressure stack is 45% of the size of the ambient pressure stack. The remaining question is whether it is less expensive to build LMFPC's or additional fuel cell stacks. From our hydrogen/air cell stack experience and the LMFPC experience gained in this program, it is probably more cost effective to build additional cell stacks. For a direct methanol system, it is still advantageous to use a LMFPC.

System Weight & Volume

According to the Perfect Gas Law, most fuel cell power system component volumes will vary in an inverse linear proportion to the pressure. If we could increase the pressure by a factor of four, then we could expect the system volume to drop by a factor of 4. Since most system components have a constant density, we could also expect the weight to drop by a factor of about 4. Several components experience larger effects. For example, the catalyst kinetics of the shift converter and reformer are greatly affected by pressure.

Cell pitch has been identified by Analytic Power as one of the most important factors governing fuel cell cost. Pressure has the very important effect of reducing cell pitch by permitting a reduction in the flow field thickness. This turns out to be a two edged sword because it is much more difficult to assure adequate gas distribution in high pressure cells.

Water Recovery

In fuel reforming power plants where a hydrocarbon is steam reformed to manufacture hydrogen for the fuel cell, water recovery from the power plant exhaust can be an important consideration. The water recovery system size varies inversely with the temperature difference between the ambient and the water vapor saturation temperature required for water recovery. A condenser in a system pressurized to about 4 atm is a factor of three smaller than an ambient condenser. An ambient condenser is often impossible.

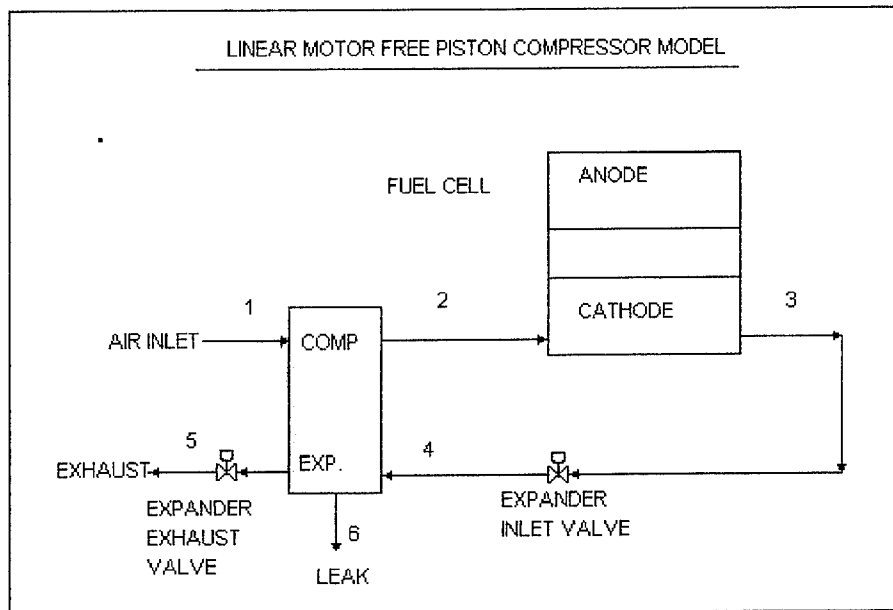

Figure 3 Linear Motor Free Piston Compressor Schematic Installation

Pressure Recovery and Efficiency

Figure 3 shows a linear motor free piston compressor in a power plant configuration where it is delivering compressed air to a fuel cell cathode and expanding the exhaust gas. Table 1 shows the molar flow rates and thermodynamic properties of the system illustrated in Figure 3. The system was simulated using Analytic Power's MicroFlo Code. A system study explored the effect of several LMFPC parameters on power plant performance. We assumed a compressor efficiency of 60% and a compression ratio of about 3.4. Power plant gross power was assumed to be about 3 kW, design voltage about 0.7 and the oxygen utilization of the power plant was 60%. We also assumed a cell temperature of about 150°F. The expander was equivalent to Analytic Power's Linear Motor Free Piston Compressor which uses an Aura Solenoid and solenoid valves from General Valve. The expander has a stroke of 1 inch and a bore of about 3.5 inches. The C_v of the Series 9 expander inlet and exhaust valves is about 5.4.

Table 1
NODE ARRAY - LMFPC
Analytic Power - MicroFlo

Node:	1	2	3	4	5	6
	lb mol/hr	lb mol/hr	lb mol/hr	lb mol/hr	lb mol/hr	lb mol/hr
H ₂	0.000	0.000	0.000	0.000	0.000	0.000
H ₂ O	0.000	0.000	0.176	0.176	0.167	0.009
CH ₄	0.000	0.000	0.000	0.000	0.000	0.000
CO	0.000	0.000	0.000	0.000	0.000	0.000
CO ₂	0.000	0.000	0.000	0.000	0.000	0.000
O ₂	0.147	0.147	0.059	0.059	0.056	0.003
N ₂	0.554	0.554	0.554	0.554	0.526	0.028
MeOH	0.000	0.000	0.000	0.000	0.000	0.000
TOTAL	0.701	0.701	0.789	0.789	0.750	0.039
T deg F	70.	439.	150.	150	10	150
P atm	1.00	3.40	3.40	3.40	1.00	3.40
H btu/hr	2605.30	4421.80	-14627.41	-14627.41	-14648.86	-731.37
S btu/hr degF	31.23	32.13	35.18	35.18	33.84	1.76

With Analytic Power's MicroFlo software, any parameter discussed in the prior paragraph may be independently varied and studied to determine its effect on the performance of the fuel cell power plant. We judged the parameters of interest to be parasite power and the solenoid power required to run the system. An air compressor affects the fuel cell power plant efficiency through the "mechanical efficiency." Power plant efficiency is the product of fuel cell, fuel processor, power conditioning and mechanical efficiency. It is also the ratio of net work to energy in. Mechanical efficiency is defined as the ratio of net power to the sum of parasite and net power.

The effect of expander efficiency and blow-by or percent leak on the solenoid power. The compressor power for the LMFPC under study is about 532 watts. This is almost 18% of the power produced by the 3kW (gross) power plant. As can be seen in Figure 4, with a reasonably

efficient expander efficiency we can reduce the power consumption to about 325 watts which is 11% of the gross power and about 60% of the compressor power. It means that the expander is

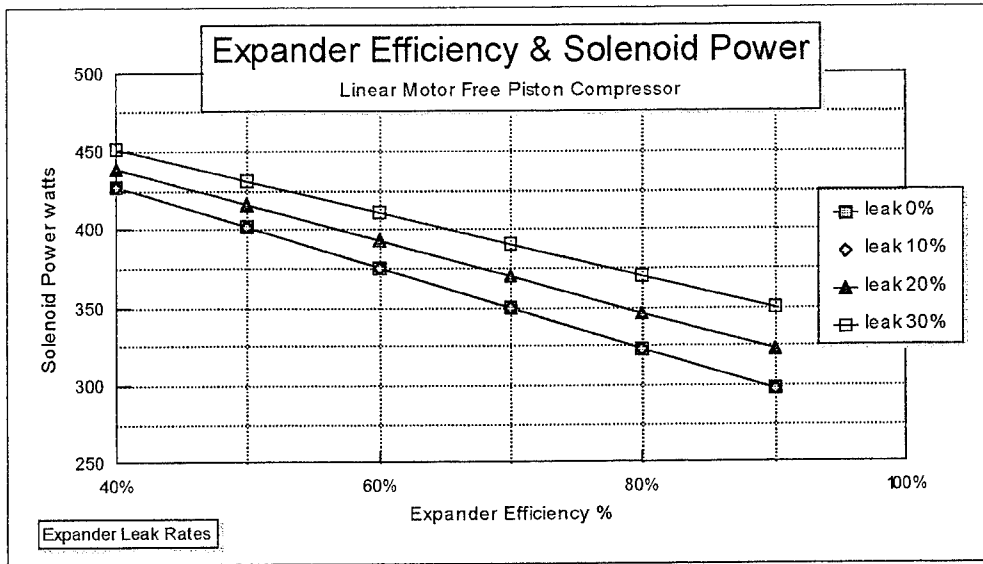

Figure 4 Solenoid Power Parametric Study

supplying 40% of the compressor power.

The study showed that the effect of compressor valve flow coefficient (C_v) was negligible. We used pressure drop data supplied by General Valve Corp. on their series 9 valves. The effect of piston ring leakage or blow-by was found to be important and is shown in Figure 4. The solenoid power in Figure 4 also contains expander valve power which is 12 watts for each of the valves.

An unknown, which can only be determined by operating tests on our LMFP, is expansion or thermodynamic efficiency. The expansion efficiency is determined by the expansion velocity profile, clearance volume, and wall heat transfer. We examined the expansion efficiency parametrically from 40% to 90%. The results of this variation are shown in Figure 4. The compressor efficiency is better understood. Analytic Power's LMFP compressor cylinder and piston assembly was made from a modified DeVilbiss compressor which has demonstrated a 60% efficiency. Piston blow-by or leakage has a strong effect on efficiency. In Figure 4, increasing the piston leakage from 0 to 20% at an expander efficiency of 70%, the solenoid power rises to 375 watts which is 70% of the compressor power.

Comparing Pressurized and Ambient Systems

The reason we considered pressurizing was to reduce the power plant size and cost. In our hypothetical 40% efficient power plant, let us assume a design cell voltage of about 0.7 and fuel processor efficiency of about 71.4%. The efficiency of the fuel cell is its voltage divided by the theoretical open circuit voltage based on the lower heating value of hydrogen. We assume that we are removing the water from the fuel cell stack as a vapor. Operating the LMFP requires electric power which drops the efficiency.

If we wish to restore power plant efficiency to its 40% level we must raise the cell voltage. We must also raise the power level back to 3 kW if we are to compare the pressurized case to the unpressurized case. Raising cell voltage and power level is accomplished by increasing the active cell area in the fuel cell stack.

With an LMFC solenoid power of about 325 watts, the mechanical efficiency is 89.17% and we must raise the cell volts to 0.785. In the case of a fuel cell stack with a motor driven compressor, and no expander, the mechanical efficiency is 82.2% and we must raise the cell voltage to 0.851.

We are now in a position to determine the effect of the electric power consumption of the LMFC on the fuel cell stack size. For this we need to compare the pressurized and ambient cell stacks on the basis of cell voltage and power density as shown in Figure 5. The one atm. fuel cell is designed at 0.7 volts per cell and a power density of 200 watts/ft². This performance level has been demonstrated in 2.5 x 2.5 inch hardware at Analytic Power. Analytic Power's ambient fuel cell stacks are usually designed at about 90 watts/ft². A fuel cell stack built to operate at high pressure using an LMFC could attain 0.785 volts per cell at a power density of about 400 watts/ft². By comparison, the power plant with a motor driven compressor and no pressure recovery could attain a power density of 200 watts/ft² at 0.85 volts per cell.

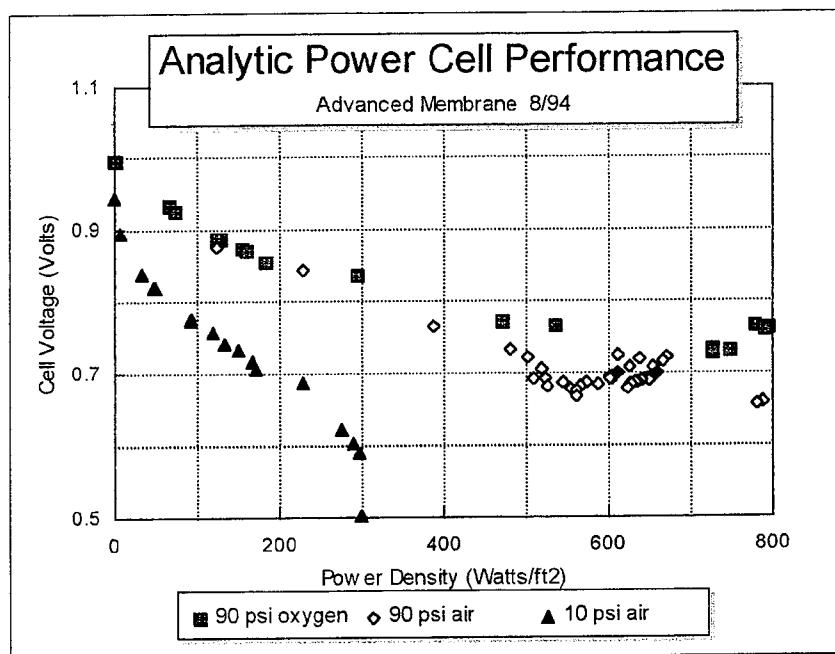

Figure 5 Advanced Fuel Cell Performance

high pressure fuel cell stack is 45% of the size of an ambient pressure fuel cell stack. The remaining unanswered question is whether it is less expensive to build LMFC's or fuel cell stacks.

Motor driven compressors, without expander power augmentation, provide no power plant advantage as they require a fuel cell stack with the same power density as an ambient pressure fuel cell stack and it must be 18% larger. The advantage of high pressure operation is more than offset by the power requirements of the compressor.

With the LMFC, the cell stack operates at twice the power density of the ambient fuel cell stack. The power increase is only 11% which means the resulting

PRESSURIZATION METHODS

Fuel cell power plants are usually pressurized with turbochargers. Because of the flow and pressure characteristics of turbochargers, pressurization is restricted to power plants over 50 kW. Free piston compressors employing linear motors extends the range to power levels of 3 - 5 kW. In this program we have combined linear motor free piston compressor technology with a solenoid valve controlled expansion engine. The LMFPC can operate at low flow and high pressure ratio. This is its principal advantage over turbochargers. The LMFPC can also operate at constant pressure and variable flow.

Linear Motor Free Piston Compressors

Linear motor air compressors and vacuum pumps are manufactured in Japan by Medo Inc. and Thomas Industries. These free piston compressors are low flow, high pressure ratio devices. The LMFPC has several distinct advantages over turbochargers. The most important are: it is quiet and simple to start and it requires no start burner or start fuel. The linear motor can be used to augment the fuel cells' expanding exhaust gases if their energy content is not sufficient to drive the compressor. This allows the LMFPC to operate at variable flow and constant pressure.

Pressure Recovery in Fuel Cell Power Plants

The thermodynamics of pressure recovery in fuel cell power plants is shown in Figure 6. The figure shows an adiabatic compression and an adiabatic expansion. The turbocharger requires that the shaft work of the turbine equal the shaft work of the compressor. Heat is added via a burner, between points (2) and (3). The turbocharger turbine inlet temperature is determined by the efficiency of the turbine, the compressor, and the pressure ratio. Using a linear compressor requires the same compressor energy. If the work available to the expander piston is less than the compressor, the linear motor makes up the difference.

Pressure Recovery with a Free Piston Engine

Figure 7 schematically shows the operation of a free piston compressor. The linear motor, which is not shown, is mounted between the compressor and expander or at one end of a cylinder housing both compression and expansion processes. During the expansion/compression stroke the pressure gradient from cylinder to cylinder is always less than cylinder to ambient and the leakage is lower. This design reduces the size, weight, and cost of the compressor.

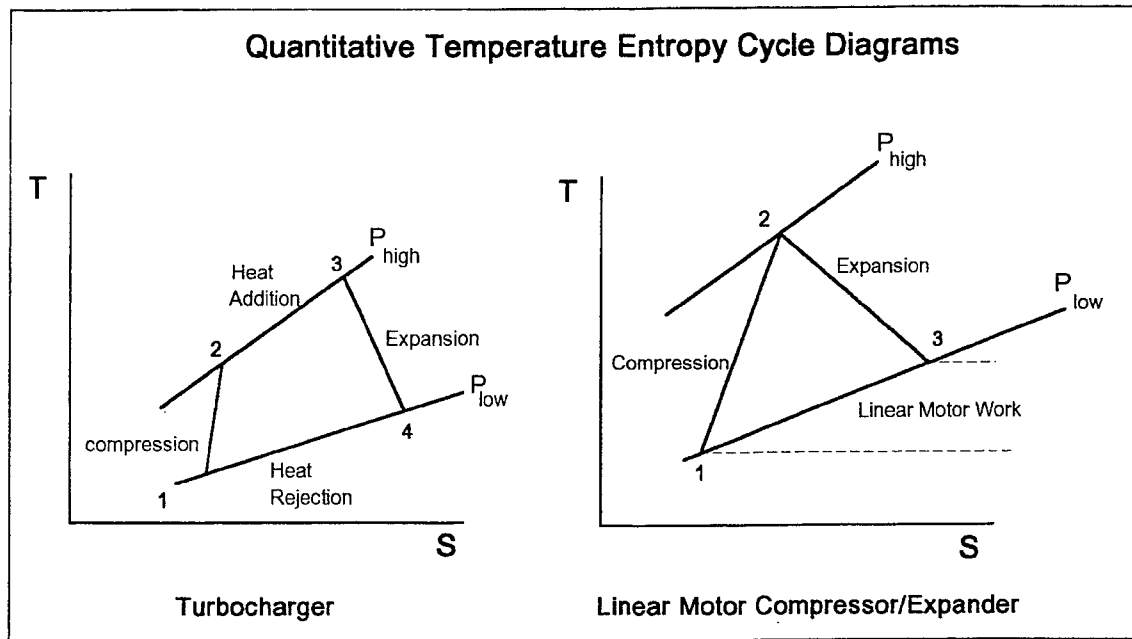

Figure 6 Comparison of Turbochargers and LMFC's on a TS Plane

The cyclic operation of the LMFC is as follows:

- (1) Starting with the piston at Left Dead Center (LDC) we start the compression stroke. All valves are closed except the cathode exhaust valve which opens, admitting exhaust to the expansion cylinder. The piston starts moving to the right. The linear motor assists in moving the piston to the right as the expansion process decays.
- (2) The anode exhaust valve closes and the cathode inlet valve opens. The piston has moved to the right and starts to deliver compressed air from the compression cylinder. Power for this portion of the stroke is supplied by expanding gases and by the linear motor
- (3) The piston has reached Right Dead Center (RDC) and the expansion exhaust valve opens. As the piston begins moving to the left the expansion products will be vented to the atmosphere.
- (4) The piston starts to move to the left from RDC and the compressor cylinder inlet valve opens. This admits fresh air into the cylinder.
- (5) This is the midpoint of the compressor inlet and expansion exhaust stroke. We continue to load the compressor cylinder with air and empty the power cylinder of exhaust products. Power for this part of the stroke comes solely from the linear motor. Because this stroke requires energy to overcome friction in the seals and gas inertia, power to the linear actuator can be significantly reduced.
- (6) At this point we have returned to the LDC position. All valves are closed and we are ready to return to step (1).

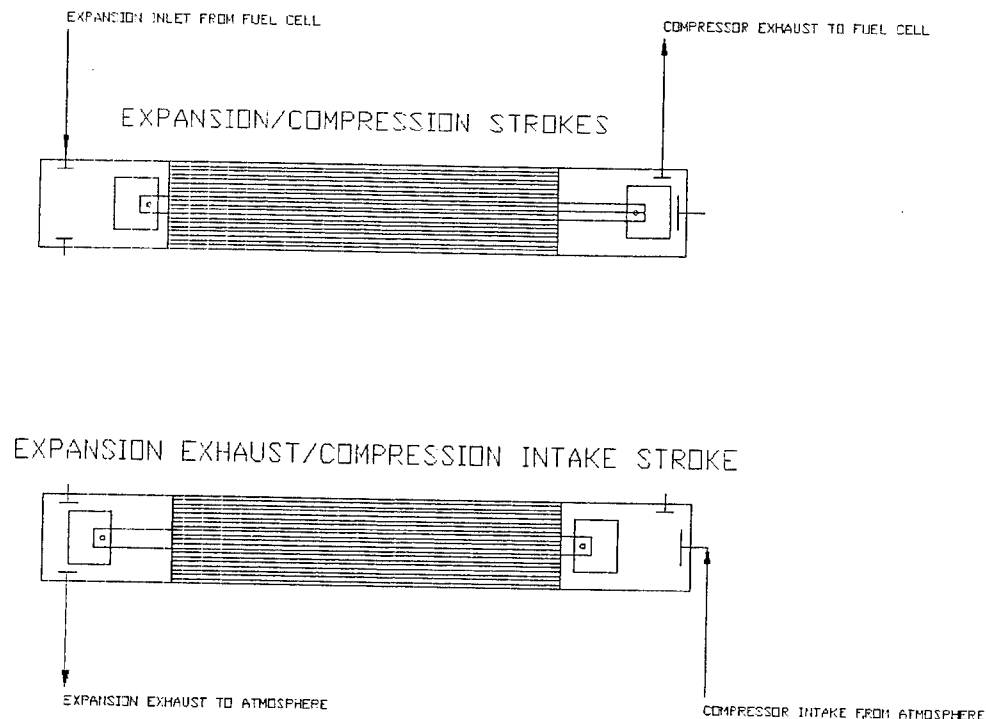

Figure 7 Cycle Schematic of LMFPC using Pressure Recovery

LMFPC Alternatives

Alternatives to LMFC's are scroll or turbine type expanders. Currently, most devices that operate on these principles are too large or require high flow rates. Our research found the scroll compressor to be the most attractive option. The scroll is a positive displacement compressor which can be run backwards to theoretically work as an expander. Scroll compressors boast high efficiencies, operate without lubrication, and are extremely quiet. Although they are too large now, scrolls are being developed for smaller pressures and flow rates. If, and when, small scroll compressors become a reality, a hard look at using the scroll will be warranted..

Turbocharging

Size and Flow Rate

The smallest commercially available turbochargers are appropriate for power systems of about 50 kW and larger. Analytic Power uses a Mitsubishi TD025 on our 10 kW fuel cell power plant. The turbocharger is a high flow, low pressure ratio device.. The target flow rate through the fuel cell stack for this application is approximately 2 to 3 SCFM. The compressor map in Figure 8 shows the pressure ratio vs flow characteristics of the the TD025. Note that the flow vs pressure ratio characteristics are limited by the compressor stall line in this map. LMFC's do not have this limitation.

Turbocharger Efficiency

While large turbochargers have efficiencies over 72%, small turbochargers have relatively low efficiencies, between 38% and 52%.

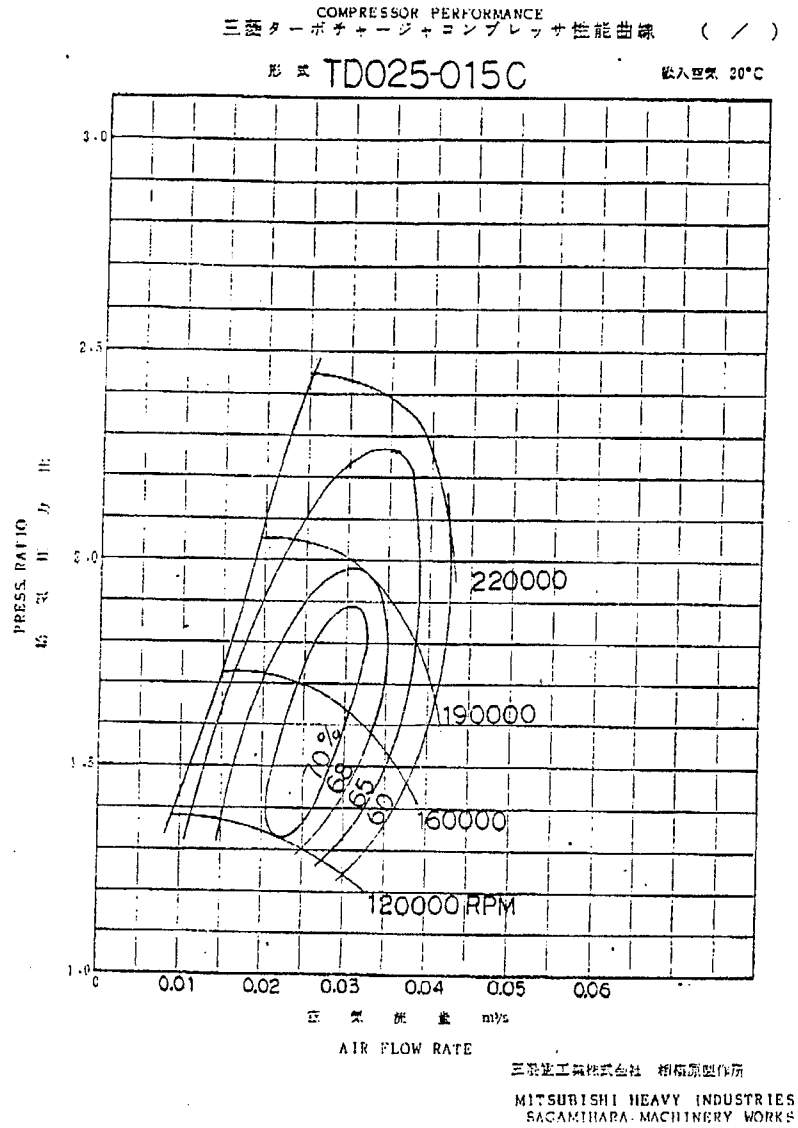

Figure 8 Turbocharger Compressor Map

Starting and Load Following

Turbochargers are difficult to start and present load following problems. The turbocharger is a heat engine that usually requires a burner to operate. Burners often cost much more than the turbocharger and are always larger. Nevertheless, the turbocharger can operate on waste heat rather than electricity and will invariably be more efficient than any other pressurization device.

Turbocharger pressure and flow rate varies with speed. The fuel cell power plant air flow is a function of power level. The result is that the turbocharged fuel cell power plant pressure is a function of power level. Alternatively the power plant must operate at constant pressure and flow

rate. In the case of the variable pressure and flow rate, a fuel cell operating at low power will have a low performance. When a transition to high power is required, the system must increase pressure so that the fuel cell performance will rise to meet the load. If the power plant is operated at constant flow rate and pressure, then the low power efficiency of the power plant will suffer. This is because the air flow through the power plant must decline whereas the flow through the turbocharger will be constant. Since the waste heat production declines with decreasing power, the heat required for turbocharging must be made up by burning extra fuel.

RESULTS

Free Piston Machines

The free piston machine is a linear, positive displacement compressor/expander which uses no crank mechanism to convert linear motion to rotation. Power generated by the expander piston is transmitted to the compressor piston by a solid connecting rod. In our LMFPC, a permanent magnet is mounted on the connecting rod and a solenoid coil surrounds the magnet. Integration of an expander with a linear compressor allows the forces developed by an expansion process to be applied to the compressor piston during the compression stroke. This allows the bulk of the compressor work to be supplied by the expansion process. The solenoid, or linear motor, supplies the deficit between the compression power required and the expansion power developed. During the expander exhaust stroke and the compressor inlet stroke, the power is supplied completely by the solenoid. Gas is admitted to and extracted from the expander cylinder by two solenoid valves; the inlet and exhaust of the expansion cycle.

Expanders

There are several conventional ways to conduct an expansion process and turn the gas energy into mechanical energy. It is important to allow the gas to expand and extract work from the expansion process. We cannot simply run a pneumatic motor. Examples of expanders include: simple piston expanders, turbines, or rotary expanders such as scrolls. Recovering energy from a scroll or other rotating expander for a linear compressor requires a transmission mechanism to convert rotary motion to linear motion. These transmission linkages tend to be bulky. Their bulk is mainly due to the operating speed of rotary equipment vs. the speed of reciprocating equipment. The torque developed by rotary equipment requires either high speed or large size. Reciprocating equipment is generally restricted to low speed because of the inertial forces generated. The conversion of rotational motion to linear motion usually involves a heavy flywheel to store energy and smooth the operation.

If we postulate a linear compressor, then the piston expander is the only way to avoid bulky power transmission equipment. The piston expander allows the energy to be directly applied to the compression process. The design focus for expanders is seals and valves. Seals for the piston expander must be able to withstand moist gases at temperatures around 200°F.

Expander Valves

While the compressor can use passive valves, the expander must use actively controlled valves. The valve timing is complicated by the absence of a rotating crank mechanism. Solenoid valves are viable but need to be fast enough to permit a complete expansion to take place. If the linear

motor operates at 20 Hz. the solenoid valve must open within half of one stroke or around 12.5 ms. A schematic of the Series 9 solenoid valve manufactured by General Valve Corp. is shown in Figure 9. It has a response time of 2 ms. This fast response time allows the linear motor to run at frequencies up to 60 Hz. The Series 9 valve runs on 24 VDC at 0.5 Amps consuming 12 watts per valve.

Power consumption is a function of how long the valve is energized. Cycling the valves between 20 and 60 Hz. results in an average power of 6-8 watts per valve. The orifice size of the port is 0.8 Millimeters standard but can be modified according to flow requirements. Currently we are testing with an 0.93 millimeter diameter orifice. Rotary valves can be used but offer no distinct advantages over solenoid valves since they consume power, need to be timed, and must be driven by a separate motor or use a mechanical transmission from the linear motor.

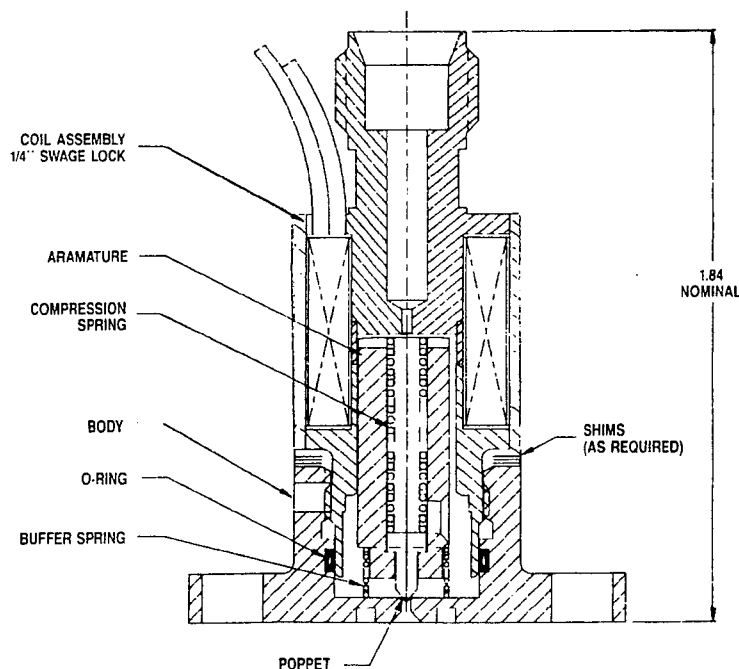

Figure 9 Schematic of Solenoid Valve

Compressors

Two compressors were studied in this program. A low flow unit and a high flow unit. The low flow LMFPFC was built for a 300 watt fuel cell power supply. The high flow unit was sized for a 3 kW fuel cell power plant.

This compressor used the head, valves, cylinder and piston from a DeVilbiss (formerly Ingersoll Rand) compressor. The head was equipped with steel finger valves. The seal is a Teflon filled bronze ring.

Non lubricated compressor seals

Non lubricated seals are a requirement of the piston design. Many different types of seals and seal materials were tested. We require non-lubricated seals because even a low vapor pressure lubricant can result in poisoning of the fuel cell cathode. The seals cannot produce any dust as this might also contaminate the cathode. Teflon composites are most widely used for non-lubricated seals. The choice of filler depends on operating temperatures, wear, frictional drag, leakage, and cost. Typical fillers are carbon, glass, and bronze. A 45% bronze filler was chosen because of its frictional and wear characteristics. The 5045 bronze filled Teflon ring has a dynamic coefficient of friction of 0.013 and has a compressive strength of 3,500 psi. These seals were successfully used in the compressor. They were recommended and manufactured by Harper Packing Corporation. The preferred ring cut for a piston ring of this type is radial. The flexible portion bisected by the radial cut expands against the cylinder wall and effectively seal the cylinder. These rings seal after warm up and limit blow-by to about 1%.

Compressor valves

The high flow compressor used the valves integral to the DeVilbiss Compressor. The head and cylinder were used, as received. Compressor valves for non-lubricated operation are primarily of the reed or flapper type. The geometry of the valve depends on the space available at the head of the cylinder. The most common type of valve, the finger valve, was used initially as the exhaust valve in the compressor and a circular finger valve for the intake. We found that by making both valves circular we were able to keep the compressor head from getting large and bulky. Figure 10 and Figure 11 show the finger valve and the circular type, respectively.

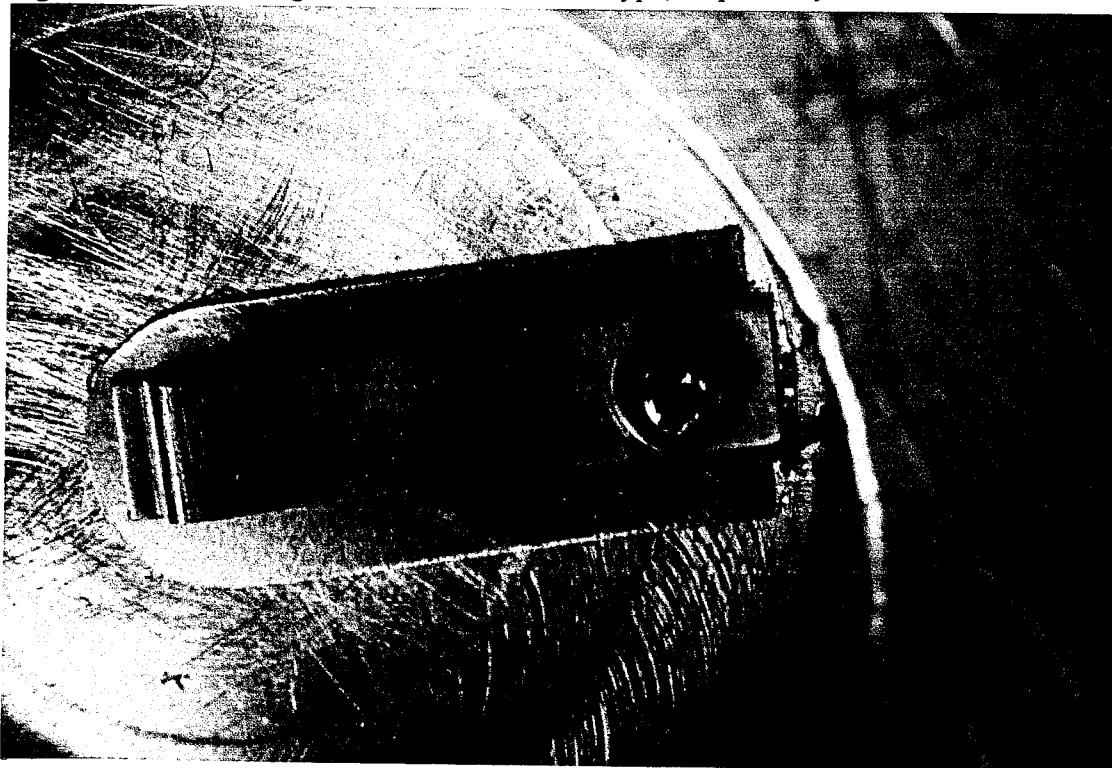

Figure 10 Finger Valve with Backing Plate

Linear Motor

High Efficiency Linear Motor

During the first year of the program we experimented with linear motors and solenoids that we built in-house. The motors developed very low force. A 90% efficient, commercially available linear actuator was purchased from Aura Systems, Inc. A schematic of the electromagnetic circuit is shown in Figure 12. The magnets ride inside a copper solenoid contained in a finned steel housing which focuses the magnetic flux. Aura's approach to focusing the magnetic flux allows generating high forces.

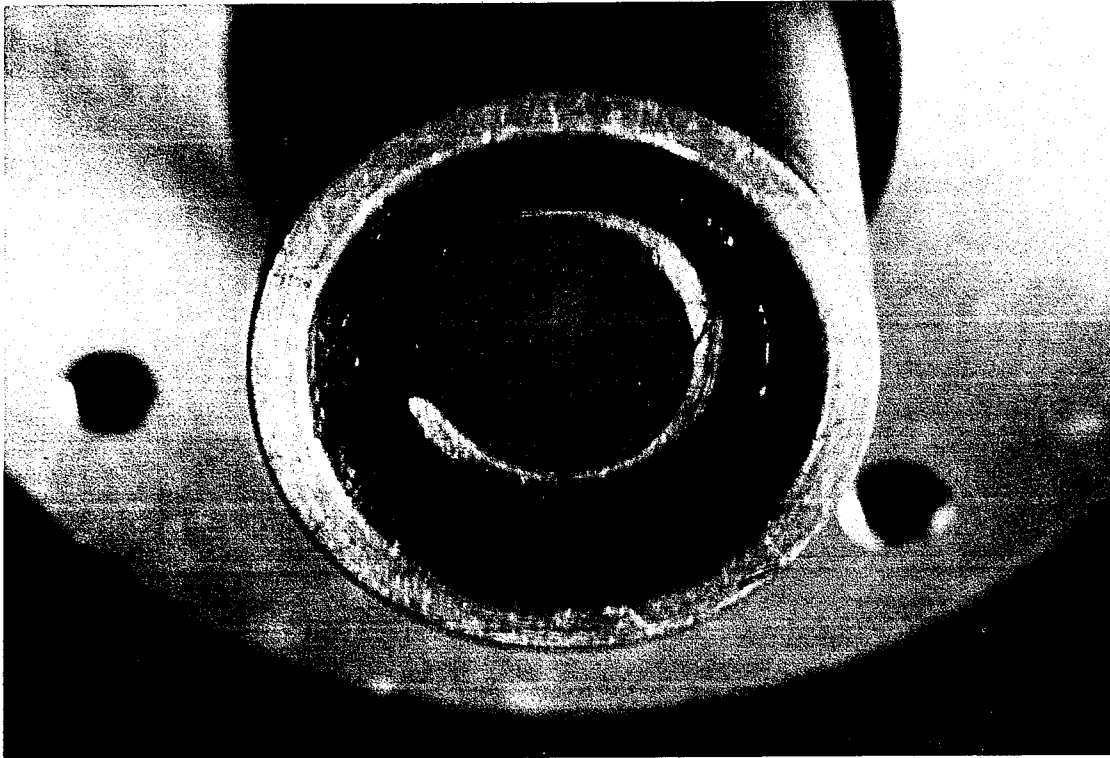

Figure 11 Circular Reed Valve with Retaining Ring

Magnetics & Operating Characteristics.

Analytic Power analyzed and experimented with the operation of solenoids and linear motors. We acquired an understanding of the operating characteristics of the magnetics of the linear motor. In our early experiments we used neodymium iron boron rare earth magnets instead of iron as the moving element. While these magnets improved the forces we could generate, they were about an order of magnitude lower than those of the purchased Aura solenoid. We also evaluated magnetics using Integrated Engineering's electromagnetic finite element software.

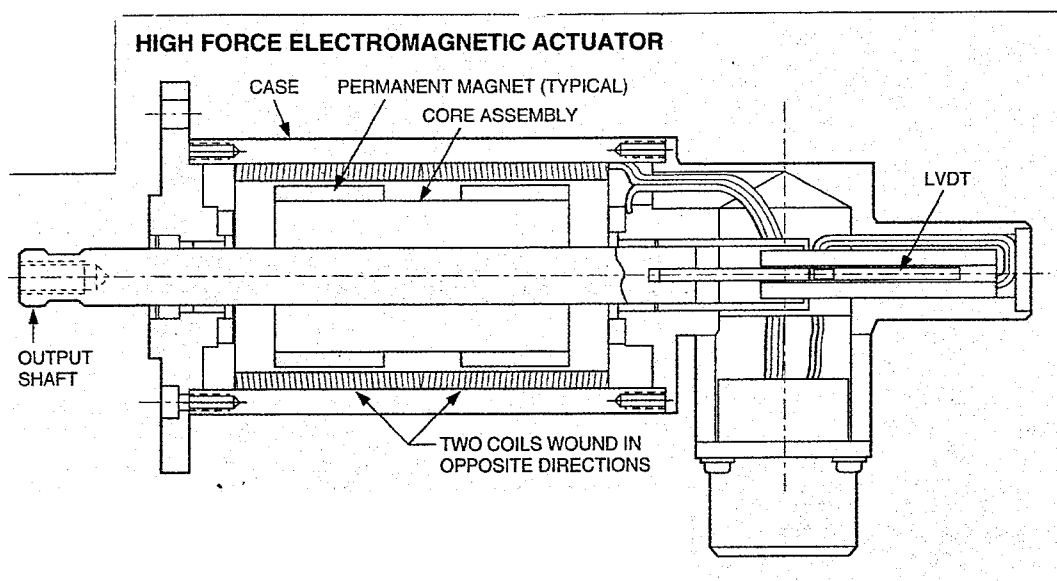

Figure 12 Aura Systems Inc. Linear Actuator (Motor)

The Aura coil can generate about 1.5 lb/amp. The current is limited by the allowable temperature of the solenoid. The forces which solenoids can generate are exponentially related to time. Likewise, the rate at which the force can be turned off is related to time. The response of the Aura coil is shown in Figure 13.

Linear motors differ from solenoids in that the coil centerlines are perpendicular to the direction of actuator motion. Figure 14 shows the forces generated by the magnetics of a linear motor. The forces presented are scaled for two dimensions. They do not represent the actual values, but give a percentage increase of force. In the direction of the motion of the compressor piston, the force increases 400% by using magnets over iron. In the direction perpendicular to the piston motion the force increases the bearings and seal load.

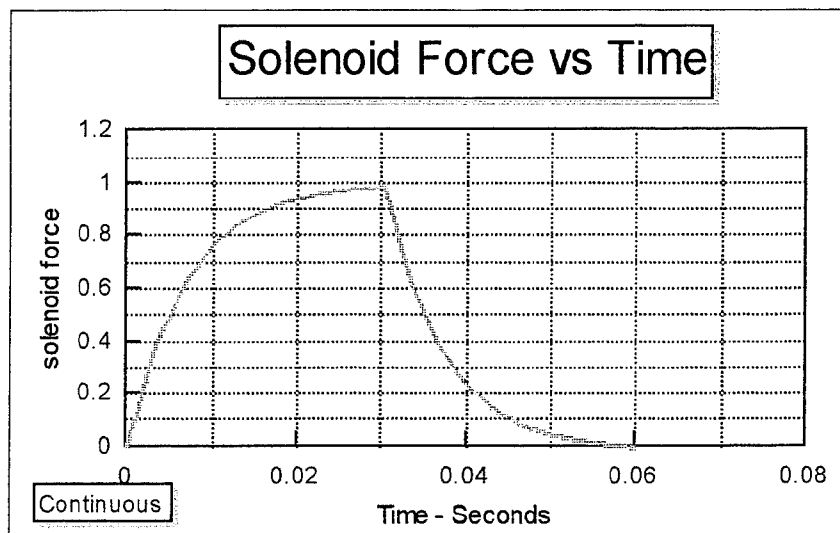

Figure 13 Operating Characteristics of the Aura Solenoid

Increases 400% by using magnets over iron. In the direction perpendicular to the piston motion the force increases the bearings and seal load.

Magnets increase the perpendicular forces by 10%. This is because the polarity of the magnet specimen is attracted to the steel core which it rides through. The iron specimen had no attractive force on it since it has no polarity. This

force is always present in linear motors. It is one of the factors favoring the use of a solenoid coil with a radially magnetized core. This eliminates the perpendicular force and prevents side loading on the seals and bearings. Figure 15 shows the radial polarization of the magnet that is used by Aura Systems Inc. While the forces generated by the linear motor or solenoid can be considerable, they are an order of magnitude lower than the gas forces present in the LMFP.

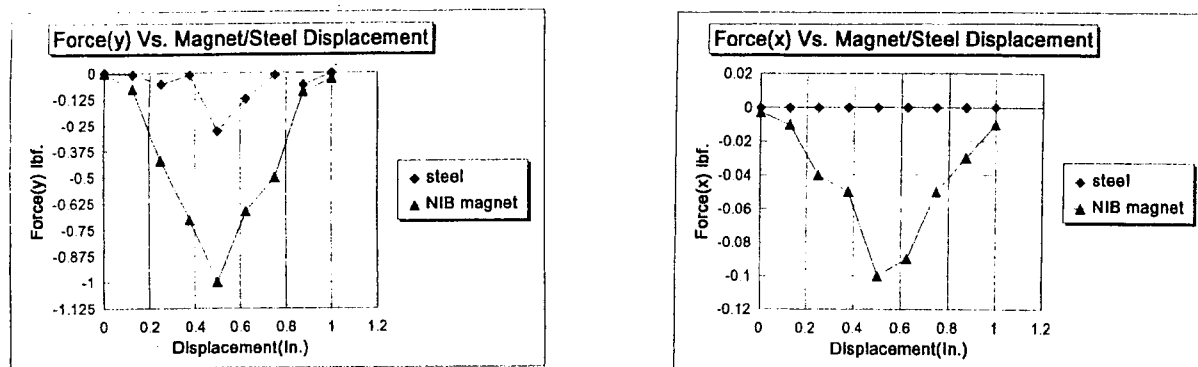

Figure 14 Electromagnetic Modeling Results

Linear Motor Bearings

The linear motor acquired from Aura Systems Inc. used roller type bearings. The bearings proved to be prone to misalignment due to uneven wear of the rollers. For short back and forth oscillating motion, roller or ball type bearings don't completely rotate hence they wear unevenly. We designed and installed Dupont Vespel sleeve bearings which were quieter, smoother, and have superior wear properties.

Power Circuit

Our initial design required applying current to the coil on the power/compression stroke. Along with compressing the gas, we expected to compress a spring so that the piston motion required for the exhaust/intake stroke would be supplied by the energy stored in the spring. The force required during the power/compression stroke coupled with the spring compression force is too high for a reasonably sized solenoid.

After almost a year of experimenting with the controller provided by Aura Systems we decided to scrap both the control and the power circuit and construct our own. The Aura circuit is designed to force oscillation of the actuator about a center point or to provide a specific force in a specific direction. Because the motion of the LMFP is not harmonic and is highly non-linear, the Aura motor control system proved completely unworkable with a piston expander.

We resolved the problem by constructing a conventional H circuit using four IRF511 MOSFETs to control current flow. The MOSFETS are mounted on heat sinks and are controlled by four 4011 Quad 2 input CMOS NAND gates. The power circuit is shown in Figure 16. While we have used large capacitors and VMOS devices to handle the high voltages encountered when the current flow through the solenoid is varied, we are currently experimenting at very low oscillating

frequencies and these protection devices are unnecessary. Shutting off the coil when it is operating at full current flow initiates a decay of the magnetic flux and induces current in the coil. The NAND gates which control the current flow through the MOSFETs are digitally controlled through the fuzzy logic controller described in the following section.

The solenoid control circuit generates a positive five volt signal, a negative five volt signal or a null. The H circuit shown in Figure 16 conducts current from the power source (fuel cell) through a MOSFET, through the linear motor or solenoid and then through another MOSFET to ground. The left hand set of NAND gates in Figure 16 activates the upper left and lower right MOSFETs which sends a current from left to right through the solenoid. Activating the opposite set of NAND gates sends current through the solenoid in the opposite direction. A null signal shuts off current flow to the coil and allows the flux to fall off, generating a self induced current in either direction.

Controlling the Linear Motor

Background

The most complex aspect of the program has been the development of a controller for the LMFPC. The Analytic Power controller integrates the operation of the expander valves with the operation of the solenoid power circuit. The LMFPC must operate over a range of frequencies corresponding to the variation of air flow in the fuel cell power plant as the load is varied. Moreover, the LMFPC must be capable of bootstrapping the power plant from low to high pressure. One of the major advantages of our approach is that the LMFPC can operate at constant pressure and variable flow. While we have not implemented it yet, the oscillation frequency will be controlled by a system pressure switch. Several control approaches were attempted before our fuzzy logic system was developed.

Phase Locked Controller

Our first attempt at controlling the LMFPC involved a harmonic circuit controller with feedback. This approach used a clock and MOSFET latches to operate the main solenoid and expander exhaust valve. The expander inlet valve was originally designed to operate from a displacement sensor. The displacement sensor was designed and built in-house but proved unworkable. An alternative approach attempted to use the clock timer to operate the inlet valve. In this design the solenoid was operated or energized in one direction only. The solenoid power was to be delivered on the power/compression stroke. A spring was to return the piston during the exhaust/intake stroke. No system was successfully operated with this type of control. The control system was only partly at fault since the solenoids used at that time developed very low forces. Since this effort was based on an assumption that the LMFPC was a perturbation from a harmonic oscillator, it would not have worked. The forces developed by the expander and compressor are

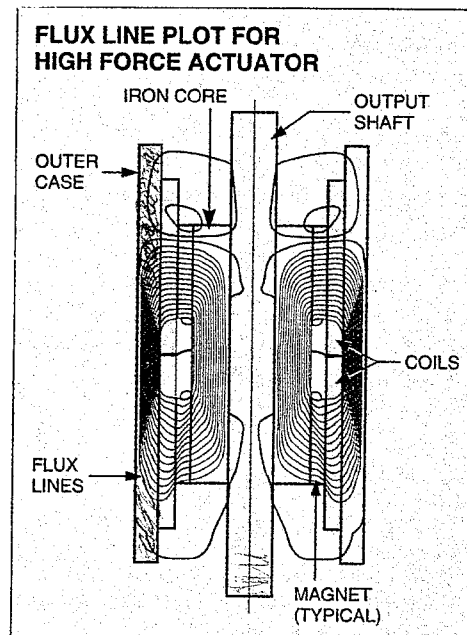

Figure 15 Aura Systems Inc. Magnet Configuration

often an order of magnitude greater than the LMFPC. It is this fact which makes the system non-linear.

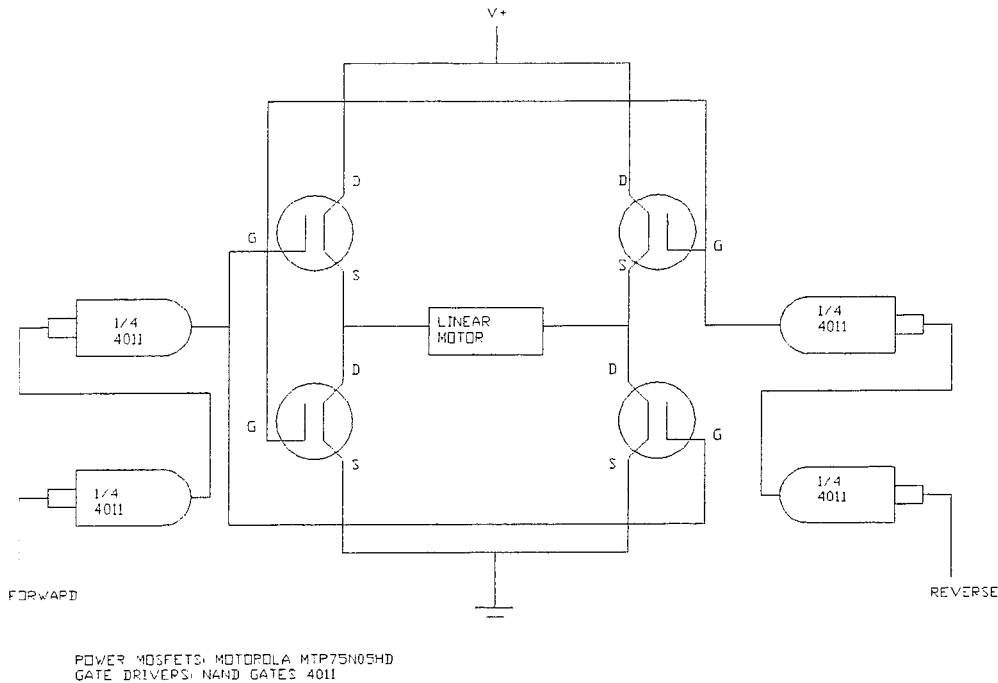

Figure 16 H Solenoid Power Circuit

Aura Systems

The Aura linear motor was equipped with a Linear Variable Differential Transformer (LVDT) which can be used to accurately locate the position of the actuator. The coil can develop about 1.5 lb of force per amp delivered to the coil. Moreover, the inductance properties of the coil are well known. The LVDT permits the actuator to be driven accurately to any position and in either direction.

The Aura solenoid is characterized by a time constant of 143 ms. Its characteristics are shown in Figure 13. The time constant makes operation of the LMFPC difficult; especially at high frequencies. Most linear motor free piston compressors operate at the natural frequency of a piston, spring and solenoid combination. Such systems cannot use an expander and cannot operate at variable flow rates and constant pressure.

The Aura motor eliminated the need for springs to keep the moving element centered and oscillating. The motor controller supplied by Aura could keep the actuator oscillating about any location. Unfortunately the oscillations had to be harmonic. A problem that is peculiar to a free piston device is the stability of the mid-position of the pistons. Since the pistons are not connected to the compressor housing, their position is determined by the applied gas, magnetic, friction, spring and inertial forces. Drift of the moving part of the compressor may occur, resulting in a collision between piston and cylinder head. While this limits the movement of the piston, it often results in unstable operation. Many linear motor free piston compressors have plastic "crash pads"

in the cylinder head. The efficiency of these compressors depends on running at the natural frequency of the spring mass system and this restriction limits the operation to a narrow frequency band.

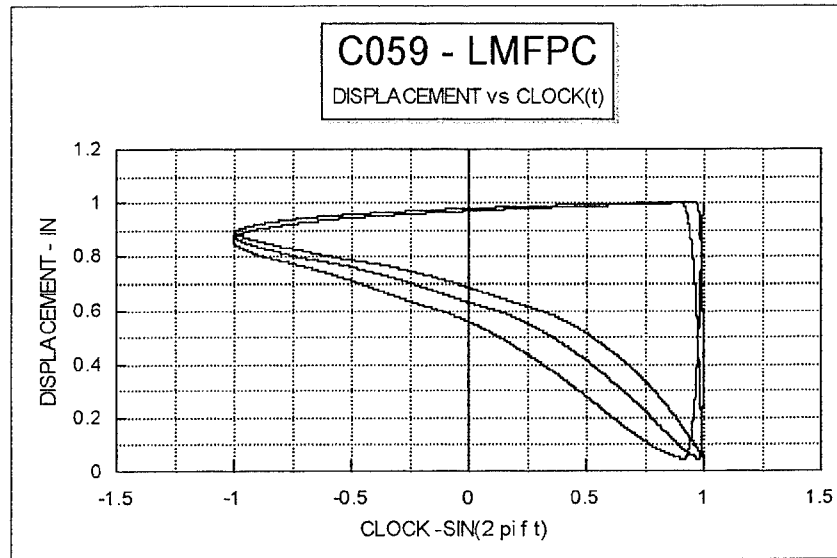

Figure 17 Displacement vs. Time Trace from LMFPC Simulation Code

By removing the spring and controlling the linear motor with a feedback system based on the LVDT eliminates the problem of piston crash. It also removes the narrow frequency band operating restriction. Because the motion of the piston is non-linear and non-harmonic, the Aura motor control system developed magnetic forces opposite to the gas forces. This result is not very efficient. Since the gas pressure forces are an order of magnitude larger than the

magnetic forces, the Aura controller was valueless and was scrapped.

Fuzzy Logic Controller

The highly non-linear characteristics of the LMFPC calls for a controller that does not depend on harmonics. A trace of the displacement vs. time function of the LMFPC is shown in Figure 18. A harmonic oscillator would yield a circular trace (see Figure 17).

Non Linear Characteristics of the System

The most important property of the system, from its control stand point is the non-linear nature of the motion. This is most easily understood by examining the phase diagram of the LMFPC which was constructed by the simulation code developed under this contract. The Phase diagram, or displacement vs. velocity graph, is shown in Figure 19. The source of the non-linearity of the LMFPC is in the gas handling systems, principally the expander. The expander and compressor forces are typically an order of magnitude higher than the solenoid force. When the expander inlet valve opens a throttling process occurs where a roughly constant force is applied to the piston for almost half the stroke. When the expander inlet valve closes, the gas trapped in the cylinder undergoes an expansion process which is an exponential function of the piston position. The exponent is the polytropic expansion exponent and its value is not exactly known. At the compressor, the opposite processes occur. In a conventional compressor or expander, a crank and flywheel are used to damp the fluctuations and make the motion approximately harmonic. In the linear motor free piston compressor, there is no such damping. This is the defining condition for a control system.

Non-linear systems are sensitive to initial conditions and errors build up at exponential rates. Controlling a non-linear system with a proportional integrating differential (PID) controller is not

possible because of the unpredictability of the non-linear system. This is why a fuzzy logic controller was developed for the LMFPC.

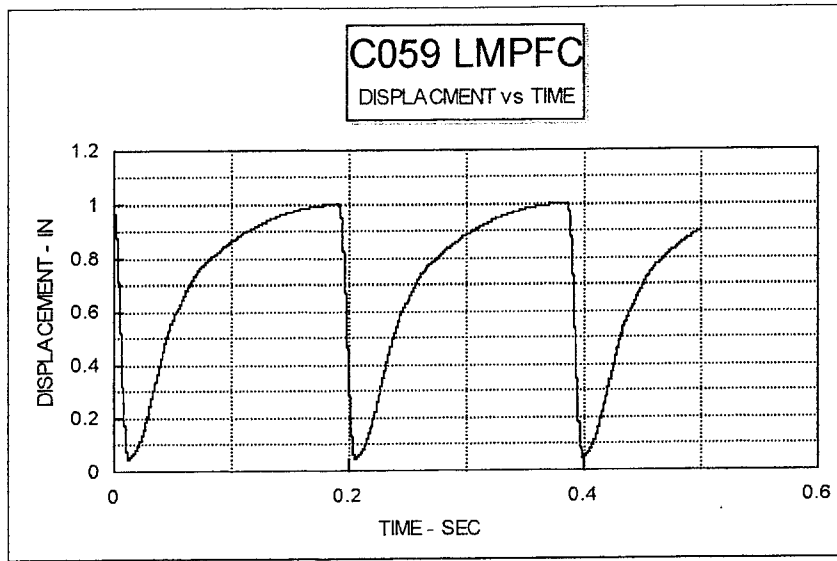

Figure 18 Displacement vs. Time - LMFPC Operating at 5 Hz

The trace shown in the Phase diagram of Figure 19 and the displacement vs. time diagram shown in Figure 18 show how a fuzzy logic unit can be used to control the operation of the LMFPC. The expansion/compression strokes start at one inch displacement. The piston rapidly plunges to the zero displacement (or close to it) and is restored slowly during the exhaust/intake stroke. The expansion/compression stroke takes the same amount of time, irrespective of the operating frequency. The return stroke is scheduled to take place over any desired time.

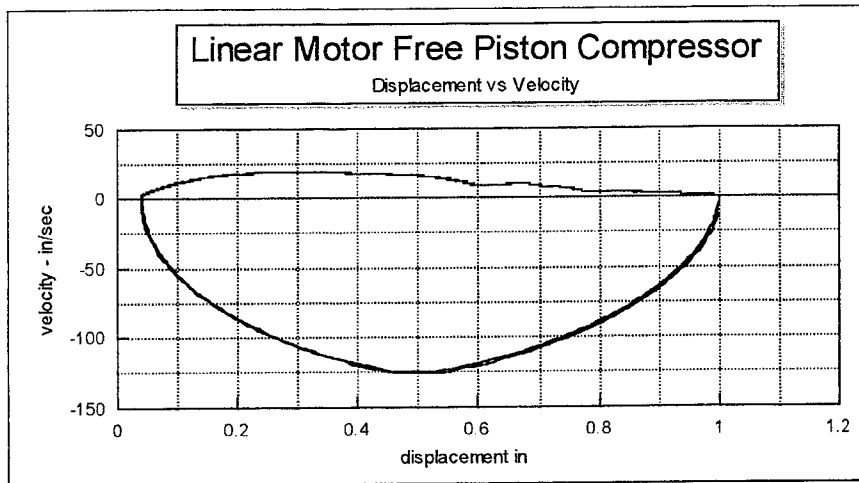

Figure 19 Phase Diagram of the LMFPC from the Simulation Code

Software

Early in the program we developed a computer simulation of the LMFC. It dynamically simulates the operation of the real LMFC under a variety of configurations. It is capable of simulating operation with or without springs and virtually any compressor or expander geometry and valve type. The control system for the present LMFC was developed and simulated prior to implementing it in hardware. The program has also been used to emulate operation of the LMFC for the development of the control electronics.

The simulator uses an Eulerian integrator. This integrator was suspect as Eulerian integrators are known to yield errors if the time step is large. We found that when the integrator was operated at time steps greater than one millisecond, the results would become significantly different than time steps less than 0.1 millisecond. A Runge-Kutta integrator was developed. While the results obtained with the Runge-Kutta system were uniform, the program took an inordinately long time to run. It gave answers no better than the Eulerian approach.

Controller

The controller consists of a computer equipped with a data acquisition and control board, the Linear Variable Differential Transformer (LVDT), four logic unit (NAND) gates which control the solenoid operation and two valve controllers. The fuzzy logic controller software takes signals from the LVDT, processes the signals and sends digital output signals which control the NAND gates and the valve controllers.

Independent Parameters

The fuzzy logic software requires two parameters to control the operation of the LMFC: position and velocity. The position signal is determined by the LVDT. The position signal is a 0-5 volt signal where zero corresponds to top dead center or the beginning of the power/compression stroke. The five volt signal corresponds to the bottom dead center position of the stroke. The velocity can be produced by the output of a differentiating circuit. Because this circuit has proven to be noisy, we are using a finite approximation to the displacement derivative generated by software.

Output Signals

The controller produces a solenoid on/up, on/down or an off signal. It also produces an on or off signal for each of the solenoid valves. The on/up signal drives the solenoid on the exhaust/intake stroke. The on/down signal drives the solenoid on the power stroke. The terms up and down have no physical significance. In the simulator screen output the down direction corresponds to the power/compression stroke and up corresponds to the exhaust/intake stroke. The main power solenoid signals are fed to the logic units which control the FET's of the main H circuit. The valve control signals are fed to voltage followers which drive the solenoid valves.

Signal Processing

The position signal is compared to the prior position signal and it is determined whether the piston is moving up or down. The velocity is determined by dividing the difference between the present and last positions by the elapsed time.

The position signal is assigned to two of five fuzzy sets describing position as bottom dead center, near bottom dead center, center, near top dead center, or top dead center. Truth value of membership in these sets are computed. Figure 20 shows a generalized fuzzy set diagram. In the case of displacement, the leftmost triangular set is top dead center. The base of the set extends from zero to 0.25 inches. The next set is near top dead center and its base extends from zero to 0.5 inches. If the displacement is 0.2 inches, then the fuzzy set membership of the displacement in top dead center is 20% and its membership in near top dead center is 80%. A similar diagram is developed for velocity. Which is also divided into five sets for up and five sets for down velocity.

The direction of velocity is determined and the magnitude of the velocity is assigned to one of five fuzzy sets: very fast, fast, moderate, slow or stop.

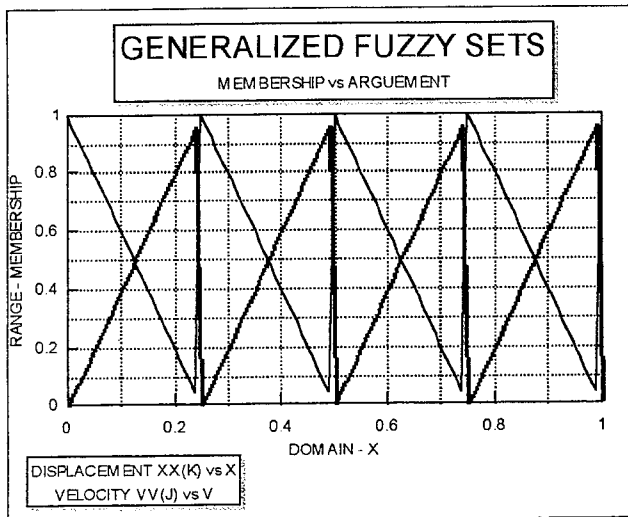

Figure 20 Fuzzy Set Membership Diagram

From the fuzzy logic sets of velocity and displacement, we generate commands for the main solenoid. These are shown in Table 2. In the table, (-1) means energize the solenoid in the down direction. The (+1) signal means to energize the solenoid in the up direction and zero means that the solenoid power supply is off or it is not up and not down. If, for example the piston is moving down moderately fast and the piston is near top dead center, we should energize the solenoid in the down (-1) direction. If the piston is moving fast in the downward direction and the piston is at bottom dead center then the solenoid should be energized in the up direction (+1). Since the position and velocity

are each members of two sets we have a total of four conditions to analyze.

Table 2 Solenoid Logic Array

		UP				
		VERY FAST	FAST	MOD	SLOW	STOP
	KX JY:	4	3	2	1	0
TDC	4	-1	-1	-1	0	0
NEAR TDC	3	-1	-1	0	0	1
CENTER	2	0	0	1	1	1
NEAR BDC	1	0	1	1	1	1
BDC	0	0	1	1	1	1
		DOWN				
		STOP	SLOW	MOD	FAST	VERY FAST
	KX JY:	0	1	2	3	4
TDC	4	-1	-1	-1	0	0
NEAR TDC	3	-1	-1	-1	0	0
CENTER	2	-1	-1	0	0	0
NEAR BDC	1	-1	0	0	0	1
BDC	0	0	0	1	1	1

The UP, DOWN and OFF signals are generated using min/max functions as specified by fuzzy logic rules of implication. Figure 21 shows the output command diagram. The leftmost set is the *up* set, the center set is the *off* set and the rightmost triangular set is the *down* set. While all sets are shown as triangular, it was found that if the direction was up and the frequency was less than 10 Hz then operation is smoother if we apply a “hedge” to the *up* command. If the frequency is greater than 10 Hz then we apply a “hedge” to the *off* command. Hedging the command means to square the membership of the set. This changes the shape of the set boundary from a straight line shown in Figure 21 to a parabola. The final decision as to what to do with the coil current is decided by the largest command set value *up*, *down* or *off*. The command signal is a digital signal of +5 volts on the Down Channel, +5 volts on the Up channel. No signal on either channel means null or Off.

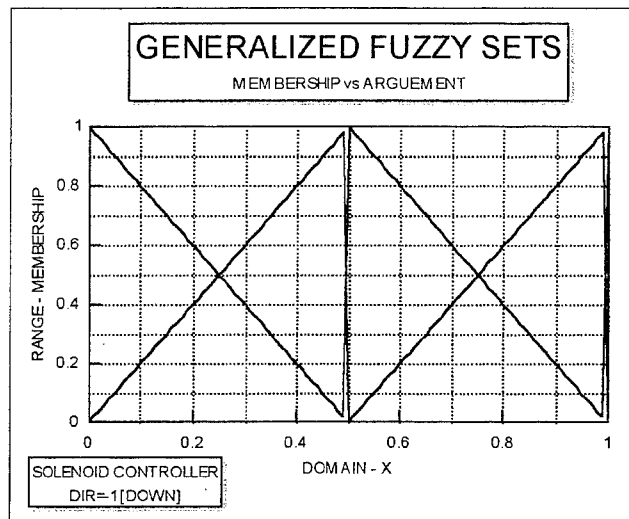

Figure 21 Output Command Sets

pressure with the compressor. The LMFC valve controller impedance is too low for the DAC output. We are in the process of replacing several chips on the DAC board and building voltage followers for the inputs to the controllers. We expect to control the actuation frequency with a system pressure signal.

RECOMMENDATIONS

Linear Motor Optimization

The geometry of the existing linear actuator does not reflect the actual size of a final design. Because of time constraints, we have been testing with an off-the-shelf actuator. When the final design constraints are known, a custom actuator can be manufactured which will be more compact.

The force available from the actuator is a function of its current. Our tests have indicated that by improving the actuator cooling, its force may be increased. Fans provided significant cooling to

Valve Actuation

The valve actuation signals, by contrast, are “crisp” as opposed to “fuzzy” signals. The expander inlet valve is opened when the position is less than a certain fraction of the stroke and the velocity is down. The fraction of the stroke is determined by the unit air charge which is used by the compressor along with the inlet temperature. The expander exhaust valve is opened whenever the velocity is up. Each of the valve actuation signals has its own channel.

Status

The controller has been used to operate the LMFC. We have not yet been able to pump

take place due to the well designed fin housing on the actuator. To further improve the actuator performance a water jacket can be installed. The temperature limit of the actuator is 150° F which can be reached quickly if supplemental cooling is not provided.

Placement of Compressor/Expander

The simplest design incorporates both compressor and expander at one end of the actuator. The configuration uses a double acting pneumatic cylinder. The design uses one piston, with the expander on one side and the compressor on the opposite side. This simplifies the assembly, reduces cost, and reduces the weight. Leakage losses are reduced.

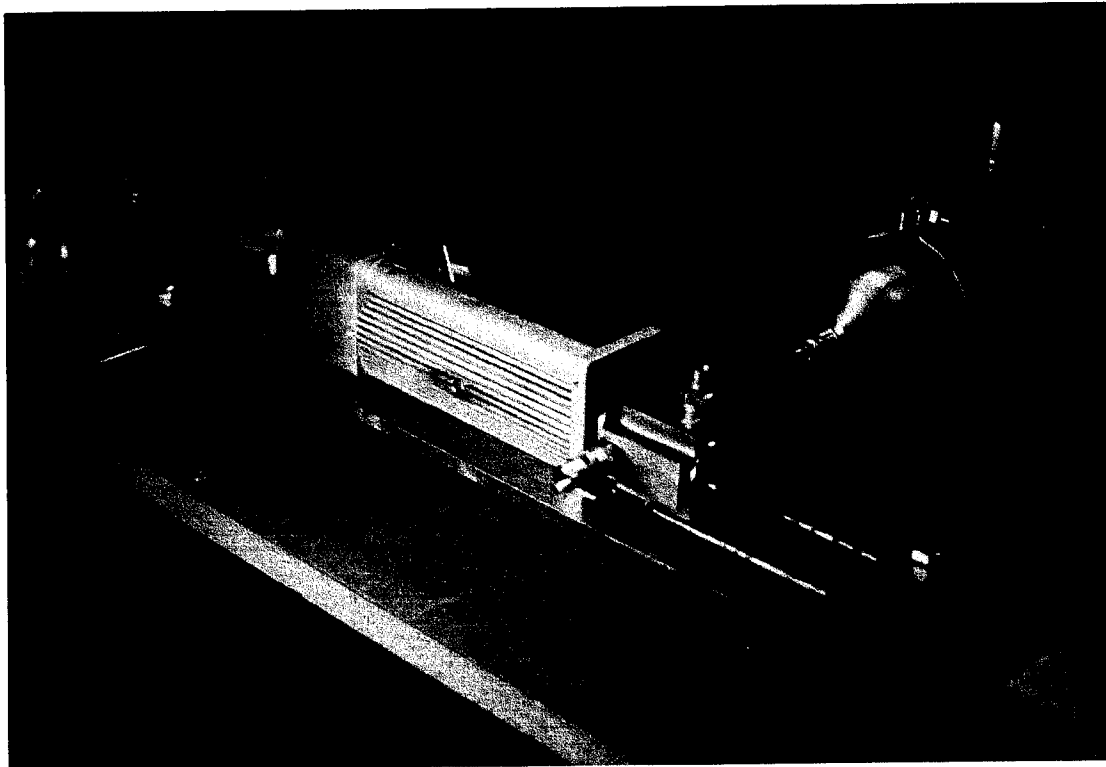

Figure 22 Single Ended Compressor/Expander Configuration

Testing and Further Development

The LMFPC has been tested at low frequencies without compressing gas. Future testing should include testing with the dummy volume included in our test stand. The test should include pressurizing the dummy volume from ambient to about 3.5 atm. The LMFPC should then undergo testing at variable flow rates and constant pressure. A test should be performed with the LMFPC supplying pressure to one of Analytic Power's fuel cells.

Testing will be used to refine the fuzzy logic controller. We believe that simplifications can be made in the number of sets used for characterizing the piston motion. The controller operating speed must be greatly increased in order to permit operation at 20 Hz.

SCIENTIFIC PERSONNEL INVOLVED

David Bloomfield, Principal Investigator
Christopher Boyle
Jose Ortiz
Michael Friedhoff

PUBLICATIONS

None