

SSC-377

**HULL STRUCTURAL CONCEPTS
FOR IMPROVED PRODUCIBILITY**

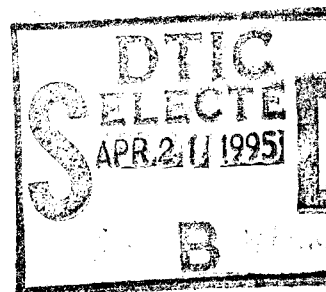
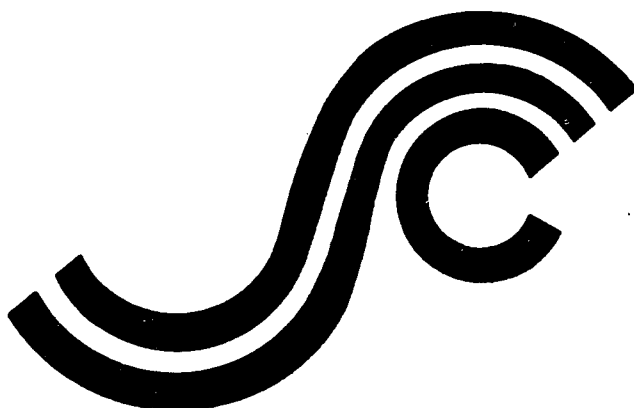

This document has been approved
for public release and sale; its
distribution is unlimited

SHIP STRUCTURE COMMITTEE

1994

19950419 125

THIS QUALITY ASSURED BY

SHIP STRUCTURE COMMITTEE

The SHIP STRUCTURE COMMITTEE is constituted to prosecute a research program to improve the hull structures of ships and other marine structures by an extension of knowledge pertaining to design, materials, and methods of construction.

RADM J. C. Card, USCG (Chairman)
Chief, Office of Marine Safety, Security
and Environmental Protection
U. S. Coast Guard

Mr. Thomas H. Peirce
Marine Research and Development
Coordinator
Transportation Development Center
Transport Canada

Mr. H. T. Haller
Associate Administrator for Ship-
building and Ship Operations
Maritime Administration

Dr. Donald Liu
Senior Vice President
American Bureau of Shipping

Mr. Edward Comstock
Director, Naval Architecture
Group (SEA O3H)
Naval Sea Systems Command

Mr. Thomas W. Allen
Engineering Officer (N7)
Military Sealift Command

Mr. Warren Nethercote
Head, Hydronautics Section
Defence Research Establishment-Atlantic

EXECUTIVE DIRECTOR

CDR Stephen E. Sharpe, USCG
U. S. Coast Guard

CONTRACTING OFFICER TECHNICAL REPRESENTATIVE

Mr. William J. Siekierka
Naval Sea Systems Command

SHIP STRUCTURE SUBCOMMITTEE

The SHIP STRUCTURE SUBCOMMITTEE acts for the Ship Structure Committee on technical matters by providing technical coordination for determining the goals and objectives of the program and by evaluating and interpreting the results in terms of structural design, construction, and operation.

MILITARY SEALIFT COMMAND

Mr. Robert E. Van Jones (Chairman)
Mr. Rickard A. Anderson
Mr. Michael W. Touma
Mr. Jeffrey E. Beach

MARITIME ADMINISTRATION

Mr. Frederick Seibold
Mr. Norman O. Hammer
Mr. Chao H. Lin
Dr. Walter M. Maclean

U. S. COAST GUARD

CAPT G. D. Marsh
CAPT W. E. Colburn, Jr.
Mr. Rubin Scheinberg
Mr. H. Paul Cojeen

AMERICAN BUREAU OF SHIPPING

Mr. Stephen G. Arntson
Mr. John F. Conlon
Mr. Phillip G. Rynn
Mr. William Hanzelek

NAVAL SEA SYSTEMS COMMAND

Mr. W. Thomas Packard
Mr. Charles L. Null
Mr. Edward Kadala
Mr. Allen H. Engle

TRANSPORT CANADA

Mr. John Grinstead
Mr. Ian Bayly
Mr. David L. Stocks
Mr. Peter Timonin

DEFENCE RESEARCH ESTABLISHMENT ATLANTIC

Dr. Neil Pegg
LCDR D. O'Reilly
Dr. Roger Hollingshead
Mr. John Porter

SHIP STRUCTURE SUBCOMMITTEE LIAISON MEMBERS

U. S. COAST GUARD ACADEMY

LCDR Bruce R. Mustain

U. S. MERCHANT MARINE ACADEMY

Dr. C. B. Kim

U. S. NAVAL ACADEMY

Dr. Ramswar Bhattacharyya

CANADA CENTRE FOR MINERALS AND ENERGY TECHNOLOGIES

Dr. William R. Tyson

SOCIETY OF NAVAL ARCHITECTS AND MARINE ENGINEERS

Dr. William Sandberg

U. S. TECHNICAL ADVISORY GROUP TO THE INTERNATIONAL STANDARDS ORGANIZATION

CAPT Charles Piersall

NATIONAL ACADEMY OF SCIENCES - MARINE BOARD

Dr. Robert Sielski

NATIONAL ACADEMY OF SCIENCES - COMMITTEE ON MARINE STRUCTURES

Mr. Peter M. Palermo

WELDING RESEARCH COUNCIL

Dr. Martin Prager

AMERICAN IRON AND STEEL INSTITUTE

Mr. Alexander D. Wilson

OFFICE OF NAVAL RESEARCH

Dr. Yapa D. S. Rajapaske

STUDENT MEMBER

Mr. Trevor Butler
Memorial University of Newfoundland

Member Agencies:

American Bureau of Shipping
Defence Research Establishment Atlantic
Maritime Administration
Military Sealift Command
Naval Sea Systems Command
Transport Canada
United States Coast Guard



Address Correspondence to:

Executive Director
Ship Structure Committee
U.S. Coast Guard (G-M/SSC)
2100 Second Street, S.W.
Washington, D.C. 20593-0001
Ph:(202) 267-0003
Fax:(202) 267-4677

An Interagency Advisory Committee

SSC-377
SR-1351

December 19, 1994

HULL STRUCTURAL CONCEPTS FOR IMPROVED PRODUCIBILITY

This report represents a landmark work for the SSC as it is the first report to focus solely on our third goal, to "Support the United States and Canadian maritime industry in shipbuilding, maintenance and repair," by specifically exploring innovative hull structural concepts from a producibility standpoint. As a first step, the report establishes foreign baselines that are used to measure alternative concepts from a construction time and labor-hour viewpoint. While there may be controversy over the labor-hour estimates, and uncertainties over the technical approach and computational judgements used, there can be no doubt of a need for substantial United States and Canadian productivity improvement relative to foreign shipbuilding.

As we look forward it is evident that our maritime industry is in a period of change and there is a need to reexamine the entire design, material handling, and production process. We need to recognize the importance of time and competitive ship delivery schedules along with increased usage of international standards, the metric system and foreign vessel designs as cooperative working arrangements are reached between our shipyards and those overseas. Our thought process must also change and reflect an emphasis on an international competition basis and the critical importance of the production time line.

I hope this report stimulates the readers to ask probing questions about the substantial differences between North American and foreign construction and impact of structural design on the overall ship producibility.

J. C. CARD
Rear Admiral, U.S. Coast Guard
Chairman, Ship Structure Committee

Accession For	
NTIS	GRA&I <input checked="" type="checkbox"/>
DTIC	TAB <input type="checkbox"/>
Unannounced	<input type="checkbox"/>
Justification _____	
By _____	
Distribution/ _____	
Availability Codes	
Dist	Avail and/or Special
A-1	

This Page Intentionally Left Blank

1. Report No. SSC-377		2. Government Accession No. PB95-144366		3. Recipient's Catalog No.	
4. Title and Subtitle HULL STRUCTURAL CONCEPTS FOR IMPROVED PRODUCIBILITY - TANKERS				5. Report Date December 15, 1994	
				6. Performing Organization Code	
7. Author(s) John C. Daidola, John Parente, William H. Robinson				8. Performing Organization Report No. SR-1351	
9. Performing Organization Name and Address M. ROSENBLATT & SON, Inc. 350 Broadway New York, NY 10013				10. Work Unit No. (TRAIS)	
				11. Contract or Grant No. DTCG23-92-C-E01029	
12. Sponsoring Agency Name and Address SHIP STRUCTURE COMMITTEE U.S. COAST GUARD (G-MI/SSC) 2100 Second Street, S.W. Washington, DC 20593				13. Type of Report and Period Covered FINAL REPORT	
				14. Sponsoring Agency Code G-M	
15. Supplementary Notes Sponsored by the Ship Structure Committee. Jointly funded by its member agencies.					
16. Abstract Alternative structural system concepts have been developed for 40K and 95KDWT double hull tankers, with the object of studying their producibility in existing U.S. shipyards, including labor hours and construction schedules. Structural components and elements considered included alternative material, shell plating, bulkheads, stiffeners and other structural elements for both conventional and unidirectional double hull tankers, together with shipbuilding processes such as automation and accuracy control, and standardization including design. It is concluded that increased automation, accuracy control and standardization are the areas where the greatest gains may be possible to make U.S. shipyards more productive and more competitive on a world scale.					
17. Key Words CONSTRUCTION COSTS, DESIGN FEASIBILITY STUDIES, ECONOMIC ANALYSIS, HULL CONSTRUCTION, HULL DESIGN, SHIP DESIGN, SHIPBUILDING COSTS, TANKER SHIPS.			18. Distribution Statement Distribution unlimited. Available from: National Technical Information Service U.S. Department of Commerce Springfield, VA 22151		
19. Security Classif. (of this report) Unclassified		20. Security Classif. (of this page) Unclassified		21. No. of Pages 240	22. Price \$36.50-paper \$17.50-microf.

METRIC CONVERSION FACTORS

Approximate Conversions to Metric Measures

Symbol	When You Know	Multiply by	To Find	Symbol
LENGTH				
in	inches	2.5	centimeters	cm
ft	feet	30	centimeters	cm
yd	yards	0.9	meters	m
mi	miles	1.6	kilometers	km
AREA				
in ²	square inches	6.5	square centimeters	cm ²
ft ²	square feet	0.09	square meters	m ²
yd ²	square yards	0.8	square meters	m ²
mi ²	square miles	2.6	square kilometers	km ²
	acres	0.4	hectares	ha
MASS (weight)				
oz	ounces	28	grams	g
lb	pounds	0.45	kilograms	kg
	short tons (2000 lb)	0.9	tonnes	t
VOLUME				
teaspoons	teaspoons	5	milliliters	ml
tblsp	tablespoons	15	milliliters	ml
fl oz	fluid ounces	30	milliliters	ml
c	cups	0.24	liters	l
pt	pints	0.47	liters	l
qt	quarts	0.95	liters	l
gal	gallons	3.8	liters	l
fl ³	cubic feet	0.03	cubic meters	m ³
yd ³	cubic yards	0.76	cubic meters	m ³
TEMPERATURE (exact)				
°F	Fahrenheit temperature	5/9 (after subtracting 32)	Celsius temperature	°C

Approximate Conversions from Metric Measures

Symbol	When You Know	Multiply by	To Find	Symbol
LENGTH				
mm	millimeters	0.04	inches	in
cm	centimeters	0.4	inches	in
m	meters	3.3	feet	ft
m	meters	1.1	yards	yd
km	kilometers	0.6	miles	mi
AREA				
cm ²	square centimeters	0.16	square inches	in ²
m ²	square meters	1.2	square yards	yd ²
km ²	square kilometers	0.4	square miles	mi ²
ha	hectares (10,000 m ²)	2.5	acres	
MASS (weight)				
g	grams	0.035	ounces	oz
kg	kilograms	2.2	pounds	lb
t	tonnes (1000 kg)	1.1	short tons	
VOLUME				
ml	milliliters	0.03	fluid ounces	fl oz
l	liters	2.1	pints	pt
l	liters	1.06	quarts	qt
l	liters	0.26	gallons	gal
m ³	cubic meters	35	cubic feet	ft ³
m ³	cubic meters	1.3	cubic yards	yd ³
TEMPERATURE (exact)				
°C	Celsius temperature	9/5 (then add 32)	Fahrenheit temperature	°F

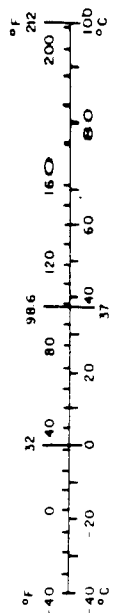

Copyright © 1994 by The McGraw-Hill Companies. All rights reserved. Printed in the United States of America. This edition is published by The McGraw-Hill Companies, Inc.

TABLE OF CONTENTS

	<u>PAGE</u>
1.0 Introduction	1
2.0 TASK I - Concurrent Engineering Requirements	
2.1 Objective	3
2.2 Philosophy of Construction	3
2.3 Design Stage	4
2.4 Approach	7
2.5 Results of Survey	
2.5.1 General	8
2.5.2 Design/Production Input	8
2.5.3 Shipyard Facility Considerations	10
2.5.4 Institutional Constraints	10
3.0 TASK II - Structural Elements	
3.1 Objective	14
3.2 Tanker Structure - Overall Considerations	15
3.3 Results	18
4.0 TASK III - Alternative Structural System Concepts	
4.1 Objective	25
4.2 Approach	25
4.3 Results	36
5.0 TASK IV - Application to Specific Double Hull Tankers	
5.1 Objective	38
5.2 Selection of Baseline Vessels	38
5.3 Baseline Construction Schedules and Labor Hours	
5.3.1 General	43
5.3.2 Construction Schedules	43
5.3.3 Labor Hours	43
5.4 Application of Alternative Structural Systems	55
5.5 Structural Blocks	58
6.0 TASK V - Estimates of Physical Production Characteristics for Alternative Structural System Concepts	
6.1 Objective	61
6.2 Approach	61
6.3 Results	65
7.0 TASK VI - Labor Hours and Schedules	
7.1 Objective	66
7.2 Approach	66
7.3 Labor Hours for Steelwork	69
7.4 Labor Hours for Construction of Complete Vessels	79
7.5 Construction Schedules	80

TABLE OF CONTENTS continued

8.0 **CONCLUSIONS** 89

9.0 **ACKNOWLEDGEMENTS** 91

10.0 **REFERENCES** 92

11.0 **BIBLIOGRAPHY OF ADDITIONAL REFERENCES** 95

APPENDIX

The following summaries in the form of tables and graphs are presented in the Appendix. Pages A30-72 require enlargement if detailed study is required.

	<u>PAGE</u>
40KDWT Base Alternative Vessel 4010 - Longitudinal Scantlings with ABS OMSEC Program	A1 - 13
95KDWT Base Alternative Vessel 9510 - Longitudinal Scantlings with ABS OMSEC Program	A14 - 28
40KDWT Base Alternative Vessel 4010 - Break Down of Blocks and Piece Parts	A29 - 44
95KDWT Base Alternative Vessel 9510 - Break Down of Blocks and Piece Parts	A45 - 60
Summary - 40KDWT Alternative Vessels - All Block Properties	A61 - 67
Summary - 95KDWT Alternative Vessels - All Block Properties	A68 - 72
Summary - 40KDWT Alternative Vessels - N ² of Pieces, Area, Weight	A73 - 74
Summary - 95KDWT Alternative Vessels - N ² of Pieces, Area, Weight	A75 - 76
Summary - 40KDWT Alternative Vessels - Weld Volume, Auto, Manual, Fillet, Butt	A77 - 78
Summary - 95KDWT Alternative Vessels - Weld Volume, Auto, Manual, Fillet, Butt	A79 - 80
Summary - 40KDWT Alternative Vessels - Weld Lengths	A81 - 82
Summary - 95KDWT Alternative Vessels - Weld Lengths	A83 - 84
Not Used	A85 - 86
40KDWT Alternative Vessels - Estimation of Labor Hours Calculations for One Tank	A87 - 105
95KDWT Alternative Vessels - Estimation of Labor Hours Calculations for One Tank	A106 - 116

TABLE OF CONTENTS continued

Plots for 40KDWT and 95 KDWT Alternatives - A117 - 122

- Comparison of Tank Steel Area
(One Side of Plate, One Tank)
- Comparison of Tank Steel Weight
- Comparison of Tank Weld Lengths
- Comparison of Weld Volumes - Includes
Factors for Weld Position and Technique
- Average Steel Plate Thickness for
One Tank Length.

Plots for 40KDWT and 95KDWT Alternatives - A123 - 127

- Comparison of Estimated Labor Hours -
Steel for One Tank Length
- Estimated Ship Labor Hours - U.S. 1994
Design and Construction
- Break Down of Cutting, Preparation and Weld
Lengths - 40KDWT Alternatives U.S. -
One Tank
- Break Down of Cutting, Preparation and Weld
Lengths - 95KDWT Alternatives U.S. -
One Tank.

(THIS PAGE INTENTIONALLY LEFT BLANK)

1.0 INTRODUCTION

It is generally acknowledged that the labor hours of constructing commercial ships in U.S. shipyards is higher than foreign shipyards, particularly those in the Far East, Southern Europe and Brazil. There are significant differences of a technical nature which will have a substantial impact, including labor hour requirements for design and construction, materials, equipment and machinery lead time, shipbuilding practices and facilities, use of standards, contractual processes, and institutional constraints.

During the past twenty years, U.S. shipyards, various agencies of the government and the Society of Naval Architects and Marine Engineers (SNAME) have tried to address the matter and improve producibility. U.S. shipyards have acknowledged the advancement of Japanese shipbuilding techniques and, together with the U.S. Maritime Administration (MARAD), have imported technology from innovators like IHI Marine Technology, Inc. (IHI), who has transferred information to Bath Iron Works Corporation, Newport News Shipbuilding, Ingalls Shipbuilding, Avondale Shipyards, National Steel and Shipbuilding Company (NASSCO) and others. MARAD and later SNAME have sponsored the National Shipbuilding Research Program (NSRP) (now under SNAME sponsorship with U.S. Navy funding), which supports extensive and varied research in shipbuilding technology from design through delivery. However, a significant gap still appears to be present between the U.S. and the major world shipbuilders.

The time required for the construction of a vessel has been identified as having a major impact on vessel labor hours. Reported delivery times in foreign shipyards are considerably less than U.S. shipyards. The reasons for this must be largely tied to the nature of the structure being manufactured and to the degree it facilitates installation of outfit and much of the painting prior to erection on the building berths. The design phase and its integration with construction has a significant influence on achieving this goal. These matters, which are in the shipbuilder's control, are addressed herein.

It is acknowledged that the world's aging tanker fleet must be replaced in the years to come. This will provide a significant opportunity to revitalize shipbuilding in the U.S. Furthermore, the passage of OPA '90 has resulted in new requirements for tankers, specifically double hulls, and this allows significant latitude for the development of designs with innovative enhancements for producibility. These could give the developer a significant advantage over the competition.

The objective of this project was to "develop alternative structural system concepts" for 40,000 (i.e. 40K) and 100K deadweight tons (KDWT) (reduced to 95KDWT later) Jones Act double hull tankers for construction in existing U.S. shipyard facilities. These should result in decreased labor requirements in the design, construction, and outfitting phases of the shipbuilding program as well as providing for low cost maintenance during the life of the vessels. It is hoped that addressing this type and these sizes of vessels will provide information to shipbuilders which will be useful in identifying improvements necessary for competing in the upcoming boom for rebuilding the world tanker fleet.

The objective of the project was approached by a series of six "tasks":

- Task I - Concurrent Engineering Requirements
- Task II - Structural Elements
- Task III - Alternative Structural System Concepts
- Task IV - Application to Specific Double Hull Tankers
- Task V - Estimates of Physical Production Characteristics for Alternative Structural System Concepts
- Task VI - Labor Hours and Schedules

Summaries of the results obtained for each task now follow.

2.0 TASK I - CONCURRENT ENGINEERING REQUIREMENTS

2.1 OBJECTIVE

Concurrent engineering is an approach to the development of a product or system which seeks to integrate design, production and user requirements from the outset, to arrive at the optimum solution in the most direct manner. The objective of this task is to define the characteristics of concurrent engineering which when applied to tanker structural design will facilitate identifying the optimum characteristics of a vessel which also result in the least construction labor hours and schedule.

Recent discussions have proposed introducing the ship construction method and sequence earlier into the design process (i.e. at the conceptual/preliminary design level), with emphasis on preliminary build strategy, subdivision of the hull into erection blocks and outfit modules, and advance planning for the development of work instruction packages during the detail design, References [1][2][3]*. The interests of the shipowner have been incorporated as well, [2]. By expanding on this approach a concurrent engineering philosophy and its characteristics for this project can be readily established.

2.2 PHILOSOPHY OF CONSTRUCTION

The objective of both the shipyard and owner should be identical in the delivery of a ship. An enlightened shipowner and shipyard manager will negotiate a contract design which simultaneously incorporates the owners' performance requirements and the yards' build strategy. However, their individual concerns along the way will be different.

Shipowners may tend to be unconcerned with the distinction between the design phases, but will seek to understand the nature of not only the principal design characteristics, but the intended detail of the construction and character of the equipment provided, in particular as to how it impacts reliability and maintainability. As an additional concern, OPA '90 has placed a significant amount of liability for spills on the shipowners, and it can be expected that their concern for risk, reliability and safety will be especially acute.

Shipyards are concerned with the design and construction details of the vessel once a contract has been signed. Theoretically, a shipyard is free to incorporate the production attributes of the organization into the design process at any stage. As personnel most experienced in production may not always be associated with the design departments, successful integration of production into design must involve a coordination of disciplines, which does not always occur.

Design, construction and shipowner requirements should be properly integrated to achieve the most desirable structural alternatives at lowest cost.

* Numbers in brackets indicate reference numbers in Section 10.0.

2.3 DESIGN STAGE

It has been noted that about 30% of the difference in productivity between the typical U.S. shipyard and good foreign shipyards can be accounted for by superior design for production in the foreign yards, [1]. Accordingly, any improvement in producibility at the preliminary design stage can have a major impact on the labor hours of ships.

The design stage in shipbuilding consists of a sequential series of design phases, i.e. Conceptual, Preliminary, Contract, Functional, Transition and Detail Phases. Transition design is the phase in which there is usually a translation of the design from a systems orientation necessary to establish functional performance, to a planning unit orientation necessary to establish production requirements.

The Conceptual/Preliminary design represents the design phase at which rough order of magnitude (ROM) price quotations may be required for a timely response to a potential buyer. Competitive shipyards simultaneously produce a material budget, which they employ with their history of man-hours required to process materials, for predicting cost. Production improvements should be fully considered at this stage in determining price. This will result in the opportunity to make a meaningful improvement in producibility before the ship construction process begins, when significant changes are still possible without disrupting the entire process. IHI advised nine-years ago "...that initial or basic designers have most affect on a ship's cost, about 60%, while at the same time the cost of their efforts accounts for no more than 3% on incurred direct costs. ...all design phases combined with material procurement activity affects 85% of a ship's cost while such efforts account for approximately 10% of incurred direct costs. Obviously, the efforts of design engineers are the most significant and decisive," [4].

The conceptual design phase establishes an overall outline design to meet an owner's outline specification. It can also define a marketable design as part of a shipyard's product development. Essentially, it embodies technical feasibility studies to determine such fundamental characteristics of the proposed ship as length, beam, depth, draft, hull form coefficients, power or alternative sets of characteristics, all of which meet the required speed, range, cargo cubic, payload or deadweight. Although the main outcome is a design to meet specified ship mission requirements, an account can and should be taken of production requirements. At this stage, the designer has considerable flexibility in his choice of dimensions and other parameters which define the vessel, and those selected can be for enhanced production. For example, the tank length versus a shipyard's maximum plate panel line length may be considered in determining the length of cargo tanks for oil tankers.

The preliminary design builds on the concept design with the intent of solidifying certain vessel principal characteristics. These usually include the vessel's length, beam, depth, draft, displacement and propulsion power. Its completion provides a precise definition of a vessel that will meet service requirements. Concurrent with the fixing of certain vessel principal characteristics, it is possible to further elaborate on the production scenario.

The contents of any design phase can be defined as a series of inputs and outputs. The concept/preliminary design inputs may be presented in the form of an outline specification or service requirements. A more complete list of inputs and outputs is given in Table 2.1. During

each of the design phases, from conceptual design through detail design, the entire ship is always addressed. The design process is really continuous definitization. At first, information is grouped in a large-frame sense with few such groups. Thereafter the design process is one of grouping information into smaller frames while increasing the number of frames. The process ends when the final grouping, detail design, exactly matches how work is to be performed.

Table 2.1:
CONCEPT/PRELIMINARY DESIGN CHARACTERISTICS
INPUT/OUTPUT

Design Input

- Service requirements, such as cargo capacity and speed.
- Routes.
- Critical components and equipment.

Design Outputs

- Preliminary specification.
- Preliminary general arrangement and midship section.
- Preliminary calculations (dimensions, capacities, weight etc.).
- Preliminary hull form body sections and lines.

Simultaneously at this stage, the shipbuilder or production discipline should identify the essential production inputs and outputs given in Table 2.2.

Table 2.2:
CONCEPT/PRELIMINARY DESIGN PRODUCTION CHARACTERISTICS
INPUT/OUTPUT

Production Inputs

- Shipbuilding policy.
- Facility dimension and capacities.
- Interim product types, including blocks and outfit modules.
- Material choices.
- Fabrication choices.

Production Outputs

- Outline build strategy.
- Preliminary block breakdown.
- Zone identification.
- Material preferences.
- Fabrication preferences.

Preliminary Arrangements. The general arrangement is among the most important aspects of preliminary ship design, as it largely defines the functional effectiveness of a vessel. The arrangement drawings must consider the functional spaces, cargo spaces, superstructure, machinery spaces and their relationships. No less important is the provision for access between all spaces, meeting operational and regulatory requirements.

During this phase, the machinery systems arrangement may be incorporated in the general arrangement. The principal components are the main propulsion and auxiliary machinery, including the main engine and large auxiliaries, electrical generators, switchboards and control areas, shafting, propellers, and the steering gear. The main engine and shafting may be the only machinery items actually shown, with space allocations provided for the remaining items.

The general and machinery systems arrangements of the nature described provide a blueprint of space allocations which can be utilized for determination of preliminary structural block breakdown, block definition and outfit module considerations. It is at this point that major changes to the design to best accommodate these production considerations can be introduced and the arrangements of the vessel altered to suit.

Preliminary Calculations. Preliminary design calculations include powering, tank capacities, weight, trim, stability and structural strength requirements. Estimates of vessel weight must be maintained during all phases in the development of the design. The designer should be aware of the placement of major machinery components and their effect on the balance of the vessel. Weight estimates are needed to establish stability, trim and list of the vessel, in addition to verifying the design deadweight. The basic weight calculations can form the basis for estimating the construction labor hours.

Although weight is an appropriate parameter for an initial labor hour estimate, it must be treated with caution. A reduction in weight will reduce the relevant material cost, but will not necessarily reduce the induced labor hours. In some circumstances, it may result in a labor hour increase as more time intensive fabrication or equipment may be involved. With the potential improvement in production resulting from a comprehensive build strategy introduced at an early stage, weight can only give a partial indication of labor hours. Labor hours as affected by producibility should impact the production more significantly than relative changes in weight.

If weight is a serious consideration, then an innovative approach based on more detailed structural analysis may provide a more optimum solution. Alternatively, a review of the main design parameters can be undertaken with an eye toward relaxation of those having the greatest negative impact. Both of these alternatives should be investigated rather than rigid applications of rules and guidelines to a weight-sensitive design, which may result in a design incorporating complex fabrication and a wide variety of material sizes. On the other hand, as it is to be expected that material costs will be less than labor costs, where weight is not a serious problem, a reduction in stiffening elements with increased plate element scantlings should seriously be considered as a means of reducing the number of welded elements and thereby reducing labor hours.

Structural Considerations. Upon completion of the preliminary general arrangement, a midship section is developed. This design development will have a profound effect on production. Basic decisions pertaining to the location of framing elements must be made along with the establishment of the material to be used in certain areas of the vessel. Consideration should be given at this time to the standardization of the elements of frame spacing, types of structural elements to be utilized and the use of minimum number of different shaped elements, all in order to simplify fabrication. Methods of structural element fabrication should be considered as well, including stiffeners and supports (rolled vs. built-up vs. flanged plate), bulkheads (plate-stiffeners vs. corrugated), etc.

In the conceptual/preliminary design phase, the designer has considerable freedom to attempt innovative structural element arrangements. As a minimum, he should avoid the use of fabricated sections which inherently have greater work content than standard rolled sections. If it is shipyard practice to utilize fabricated sections, then this option should be re-analyzed.

This task considers the alternative structural system concepts for tankers in the context of conceptual/preliminary design. Accordingly the aspects of these phases as just discussed will be considered and some of the design/production input/output characteristics presented in Tables 2.1 and 2.2 applied to the structural alternative system will be identified.

2.4 **APPROACH**

In order to obtain concurrent engineering input from knowledgeable parties, contacts with shipbuilders, shipowners, designers and classification society representatives were made as follows:

- American Bureau of Shipping Tanker Seminar with shipowners, shipbuilders, designers and Classification Society personnel.
- NSRP Panel SP-4 Design/Production Integration.
- Conducted 3 shipowner interviews.
- Conducted 1 shipbuilder interview.
- Received information from 2 shipbuilders.
- Received information from ship surveyor.
- Received comments from Government Agencies.

The inquiries addressed those requirements related to the design/production outputs given in Table 2.1 and 2.2 and the desired characteristics of the components of double hull tankers of 40K and approximately 100KDWT. Simultaneously, a literature search was conducted to identify information pertinent to the project and to identify gaps in the literature which might be filled by input from the marine community. In order to address gaps in background data obtained as a result of the above, two questionnaires were also developed, one aimed at owners and the other at builders. The information requested therein was relevant to Tasks I & II, and also addressed Alternative Structural System Concepts for construction of tankers.

2.5 RESULTS OF SURVEY

2.5.1 General

The features of the concept/preliminary design and production input/output characteristics identified in Tables 2.1 and 2.2 were considered in grouping the information collected from the survey described in Section 2.4. This information has been highlighted herein and utilized later in the appropriate remaining tasks. A summary of shipyard facility considerations is also provided, followed by a discussion of institutional restraints. Construction schedule and labor hour data obtained are discussed in Section 5.3.

2.5.2 Design/Production Input

2.5.2.1 Design Input

With regard to design, the following input was established from the survey:

- **Service requirements -**
The vessels studied were to be 40K and 100KDWT Jones Act double hull tankers. However, it was established that tankers in the 100KDWT size range are being constructed internationally in Aframax sizes of 95KDWT. For consistency, comparison purposes and application to the international market, this capacity has therefore been adopted herein in lieu of 100KDWT.
- **Routes -**
The routes include those for the U.S. Panamax and Aframax type Jones Act trade vessels.
- **Critical components and equipment -**
Risk in design is a significant potentially overriding concern for a shipowner considering the scope of liability in the event of an oil spill. Components, equipment or structural alternatives which are not based on previous full scale experience inherently introduce risk through possible failure.

The availability of machinery and equipment relies on many foreign vendors. Owners may have typical lists of acceptable vendors, many of which are foreign and with which U.S. shipyards have had limited interchanges.

The 40K and 95KDWT vessels should be single screw with medium speed twin diesels or slow speed diesel, dependent on owners preference. Maintenance and repair requirements should be given a high profile.

2.5.2.2 Production Input

With regard to production, the following input was established from the survey:

- **Shipbuilding policy -**

To suit structural alternatives within constraints of U.S. shipyards without facilities enhancements.

Environmental restrictions may impact on construction practices, coatings, etc..

Incentives for workers may be considered as a means to increase productivity; what are trade/union restrictions?

Fitting accuracy is very important in block production. The less rework due to poor marrying of blocks, the faster the hull will be erected.

Side blocks should be landed on the bottom blocks. Production capabilities will be different between 40K and 95KDWT vessels; what may be possible with one, may not be possible with the other.

Landing inner bottom plating above bilge turn is good practice for producibility, although generally not applicable to double hull tankers.

With regard to machinery/outfitting, owners should provide any specific material coating and equipment preferences and reasons for preferences; i.e. types of pumps, pump locations, equipment makers, coatings, materials, cable types, cable trays, piping arrangements, valve types, valve locations, windlass arrangements, hose arrangements, etc.

- **Material and fabrication choices -**

It is considered that the more conventional large double hull tankers will be constructed of high strength steel (HSS) at the deck and bottom, with mild steel (MS) in the mid height section. This is to take advantage of the higher bending stress and reduced thickness afforded by the HSS (typically AH32). One would expect the more unusually configured vessel such as the unidirectional hull, with its complete double envelope and unusual number of girders, to be constructed of mild steel throughout, since its longitudinal strength is very high and high strength steel is generally not required. Of course, it may be made lighter with the use of HSS, but the cost factor would have to be considered and evaluated.

Compound curvature in plates should be severely limited, including the bulbous bow shape which can be simplified.

High strength steel is considered less the ideal material than previous, due to fatigue problems experienced in ships with less than optimum attention to detail. Corrugated versus stiffened plate bulkheads is mostly an owners choice.

There are welding problems in U.S. yards with joining bulb flats, resulting in poor quality weld splices.

There is a question as to where on a vessel to introduce transverse framing, which is less production friendly than longitudinal framing. Transverse framing may sometimes be installed at the ends of otherwise longitudinally framed vessels, due to the amount of twist required in end longitudinals.

Bilge plates without longitudinals and possibly also without brackets, are good from a production viewpoint.

Lapped joints in plating may be acceptable in non-critical areas, but may be more expensive than butt joints.

Tapered plating is not liked, possibly due to cost.

2.5.3 Shipyard Facility Considerations

Table 2.3 depicts what is considered to be an existing U.S. shipyard, that is, one that would be capable and interested in competing in the world commercial ship market (adopted and modified from [5]). Table 2.4 depicts a notional shipyard, which may be considered typical of a modern foreign shipyard.

The study herein is concerned with existing U.S. shipyards without significant facilities enhancements. Consequently, the data contained in Table 2.4 is presented for informational and comparison purposes only.

2.5.4 Institutional Constraints

The burden of institutional constraints, in the form of the added cost of compliance with U.S. regulations in the marine industry, has often been cited as a significant contributor to the high cost of building commercial ships in the U.S. This subject was discussed in Reference [6], specifically with regard to the impact of U.S. Coast Guard (USCG) regulations. Some important points extracted from this paper are as follows:

- U.S. shipbuilders have little choice, in many cases, but to purchase marine machinery and equipment from foreign vendors. According to a recent statement by the Shipbuilders Council of America (SCA), foreign manufacturers of marine machinery charge premium prices, adding an average of 15% to the material costs of a U.S.-flag ship built in a U.S. shipyard, to cover the costs - real or perceived - of compliance with USCG design and inspection requirements for U.S. flag ships. The cause of this is the erosion of the U.S. supply base for marine equipment and material.
- The American Commission on Shipbuilding, created by Congress through the Merchant Marine Act of 1970 in its "Report of the Commission on American Shipbuilding" cites an addition of 3-5% of the cost of a U.S.-flag vessel for compliance with the technical

requirements of the Coast Guard, American Bureau of Shipping (ABS), and U.S. Public Health Service. Other added costs are cited which range from a low of 1% to a high of 9% of total vessel cost. These differences in cost were largely attributed to implementation of the International Convention for the Safety of Life at Sea, 1974 (SOLAS 74) and its Amendments. The impact of this was particularly severe on the conversion of older ships built before SOLAS 74. However, it should be noted that SOLAS 74, as amended, and other IMO requirements, have minimized the difference between design requirements in force worldwide and those in USCG regulations.

- The cost of ABS classification has been cited as an "add on" cost; however, all commercial ships in foreign trade must be classed by a reputable classification society in order to obtain insurance, and the technical standards and service charges of the leading Classification Societies are not all that different.
- It is not clear whether all percentages quoted are based on total ship cost or the price the purchaser pays the shipyard for the ship, which may exclude sizeable foreign government subsidies.
- While the percentage figures quoted vary widely, it appears that some small incremental cost of compliance with USCG regulations exists. USCG is sensitive to this incremental cost and continues to make efforts to reduce the regulatory burden. In any case, a U.S. flag vessel built in a foreign shipyard or within the U.S. is required to comply with the same regulations. Therefore, the differences in cost and added time for approval may then be in favor of the vessel building in a U.S. yard.
- USCG regulations are not applicable to foreign flag ships even if built in U.S. yards. The absence of foreign flag shipbuilding in the U.S. must be attributed to factors such as long delivery schedules and corresponding high costs at U.S. yards, not any "added" cost of compliance with USCG regulations.

Table 2.3: EXISTING U.S. SHIPYARD

- Mid 1980 technology steel processing and fabrication shops, material handling and crange. \$5 - 10 mil annual improv.
- Facilities
 - Plate stockyard
 - Shape stockyard
 - Plate treatment
 - Shape treatment
 - Plate processing shop
 - Shape processing shop
 - Panel line
 - Subassembly shop
 - Assembly shop
 - Shaped assembly shop
 - Block platens
 - Treatment and coating
 - Shop/platens to berth handling
 - Berths
 - Pipe shop
 - Equipment module shop
 - Outfitting quay
- Equipment
 - Includes plate and shape pre-processing treatment.
 - N/C burning machines, plate rolls and presses.
 - Line heating, frame bending by hydraulic machine. Panel line for flat stiffened panels. Welding. Subassemblies are processed in designated area and fed to both panel line and shaped structure shop. Pin jigs are used for shape structure. Some multi-wheeled transporters used.
 - Equipment and piping produced in outfit package shop.
 - Conveyors, overhead cranes in shops, panel and block transporters, outfit pallet trucks, platen cranes and berth cranes are all material handling.
- Designated "On Block" outfitting before or after block coating treatment.
 - Deckhouse panels assembled in specialshop for "On Block" outfitting.
 - Joiner work done after completion of structure and outfitting.

Table 2.4: NOTIONAL SHIPYARD

- Equipment
 - Includes plate and shape pre- processing treatment w/ conveyor handling.
 - Line heating, frame bending by hydraulic machine w/ computer templates or inverse lines. Panel line for flat stiffened panels w/ one side welding and automatic stiffener welding. Panels and shaped structure are joined to form 3 dimensional blocks at outside platens.
 - Equipment and piping produced in outfit package shop.
 - Submerged Plasma cutting/computer controlled.
 - Mechanized steel storage handling with remote identification and sensing.
 - Cranes with magnetic or pneumatic lift.
 - Automatic beam forming.
 - Computer fairing, straking, nesting and layout.
 - Modular scaffolding.
 - Self-traveling staging
 - Block or module turning gimbals.
 - Hydraulic block alignment systems.
- Complete design, engineering and CAD.
Design for production emphasized. Suitable documentation to suit structural block and zone outfitting.
- Welding
 - With Fluxcore Wires (FCW welding).
 - Welding robotics for the more difficult areas.
 - Laser Welding.
- Process lanes.
- Statistical accuracy control.

3.0 TASK II - STRUCTURAL ELEMENTS

3.1 OBJECTIVE

The objective of this task is to identify structural elements which can be utilized in assembling alternative structural system concepts having the potential of improving the producibility of double hull tankers. The characteristics of the structural elements which can be utilized in assembling structural systems for double hull tankers will be identified first. These include tanker structural arrangements, individual structural components, structural standards, and processes. This was achieved by the identification of structural elements utilized in the past, proposed concepts, variations suggested by new and relatively modest fabrication equipment, and characteristics suggested for possible reduction of potential oil pollution.

At this stage, it is useful to define some structural terminology as used herein - see Table 3.1

Table 3.1: STRUCTURAL TERMINOLOGY

Structural Elements.

Fundamental features of a structure, such as individual components, type of framing (longitudinal or transverse), flat versus curved plating, incorporation of structural standards etc., or a production process such as plate forming, flame burning or welding.

Structural Standards.

Standard designs of such items as webs, brackets, collars, outfit modules, etc.

Blocks.

Pre-assembled portions of ship's structure. Blocks may be 2-dimensional, such as a stiffened panel of plating, or 3-dimensional, such as a portion of a double bottom or wing tank. Blocks may be pre-outfitted, i.e. portions of outfit such as piping, access hatches, ladders, etc. may be installed prior to erection of the block on the building berth.

Modules.

Outfit assemblies consisting of functionally related components and fittings (such as a pump unit with associated piping, valves, etc.) mounted on a steel frame ready for installation in the ship. Applies particularly to machinery spaces.

Process Lane (or Street).

A group of work stations designed to produce a family or families of products which require similar processes.

3.2 TANKER STRUCTURE - OVERALL CONSIDERATIONS

Tank vessels have been traditionally designed as single skinned hulls with transverse and longitudinal bulkheads. The overwhelming majority of such vessels are longitudinally framed, (Figure 3.1). Because of major oil spills and the resulting damage to the environment, the U.S. Congress mandated in OPA '90 the use of double skinned tanker designs, (Figure 3.2) as an effective means to protect the ocean environment from potentially devastating oil pollution. Since then, a number of alternative generic configurations have emerged as well, most prominently the mid-deck design, (Figure 3.3), and are being considered by the international community, although not permitted by OPA '90. Such designs are not therefore considered herein. All of the new designs are aimed at achieving the same objective, i.e., reduction of the amount of outflow in the event of hull puncture.

The function of a tank vessel's structural system may be viewed from the standpoints of normal operation and casualty operation. In providing adequate resistance for normal operations, the objective in structural design is to maintain structural integrity of the hull girder, of bulkheads, decks, plating, stiffeners and details. Other design considerations relate to vessel size, complexity and weight of the structure, producibility, and maintainability. In terms of casualty operations, the objective is to maintain vessel integrity and to protect cargo, or, conversely, to protect the environment from oil pollution in case of a casualty. In this case, the primary structural design considerations should encompass:

- Resistance to fire and explosion damage and its containment.
- Resistance to collision and grounding damage.
- Containment of petroleum outflow if damage does occur.
- Maintenance of sufficient residual strength after damage to permit salvage and rescue operation.

Tanker structure is characterized by structural arrangements consisting of a number of elements oriented in repetitive patterns. Examples are the traditional transverse system consisting of transverse frames supported by girders and bulkheads, and the longitudinal system consisting of longitudinal girders and frames supported by transverse web frames and bulkheads. These have been incorporated in most tanker construction to date. However, the transverse system has largely been discontinued for tankers (except in the bow and stern) in consideration of the minimization of steel weight.

In recent times, unidirectional double hull structural systems have received attention from the commercial community, [7] [8] [9]. Specifically, this hull structural system uses a double hull structure supported between transverse bulkheads by a series of longitudinal girders between the inner and outer hulls (Figure 3.4). Structural simplification is significant, with intersections between the longitudinal and transverse members reduced to a minimum. Longitudinal stiffeners have been eliminated except for the girders, which are spaced wider apart than conventional longitudinals. As a result, the thickness of shell and other plating increases, resulting in heavier hull structure than that of the more conventional double hull tankers. However, the number of pieces and unique pieces required for construction decreases considerably. Other new unidirectional concepts have been developed as well, such as the dished shell plate system, [10] - see Figure 3.5.

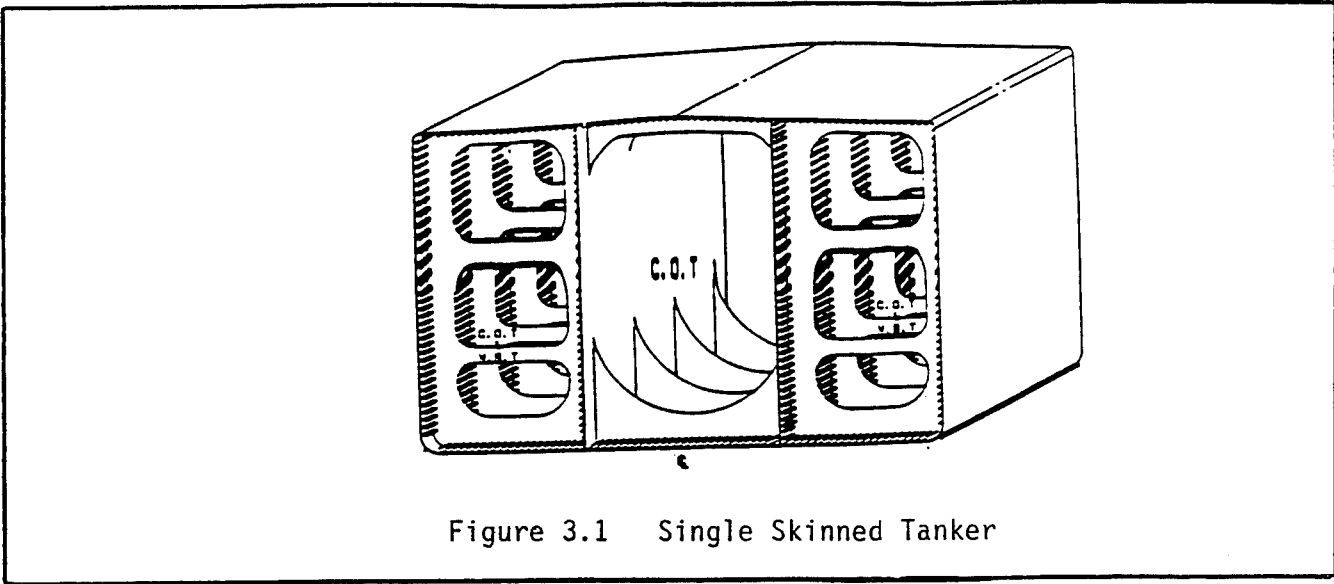

Figure 3.1 Single Skinned Tanker

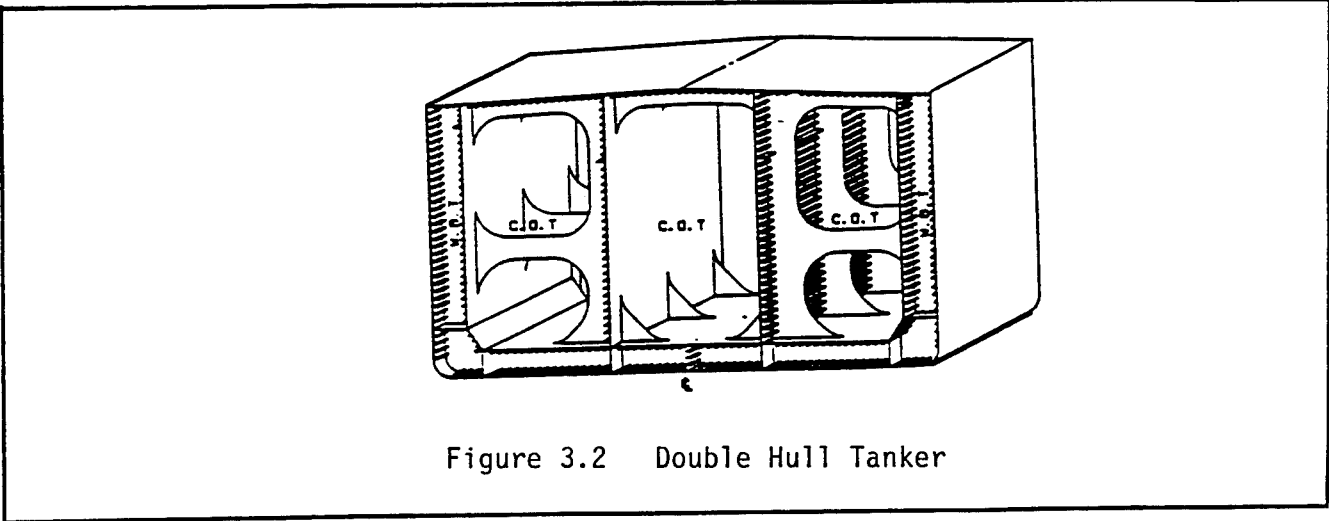

Figure 3.2 Double Hull Tanker

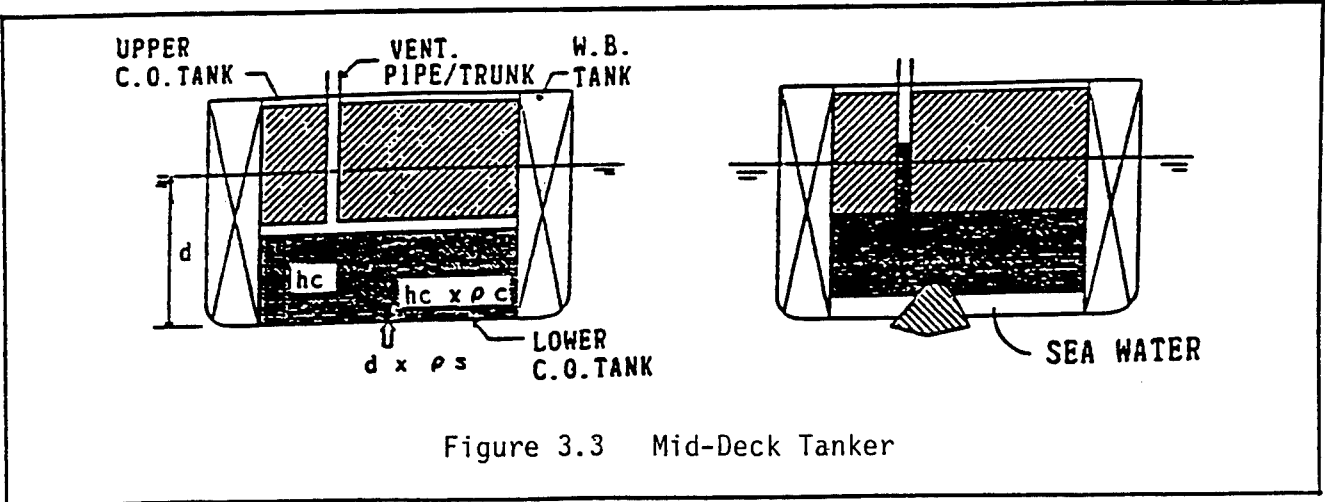

Figure 3.3 Mid-Deck Tanker

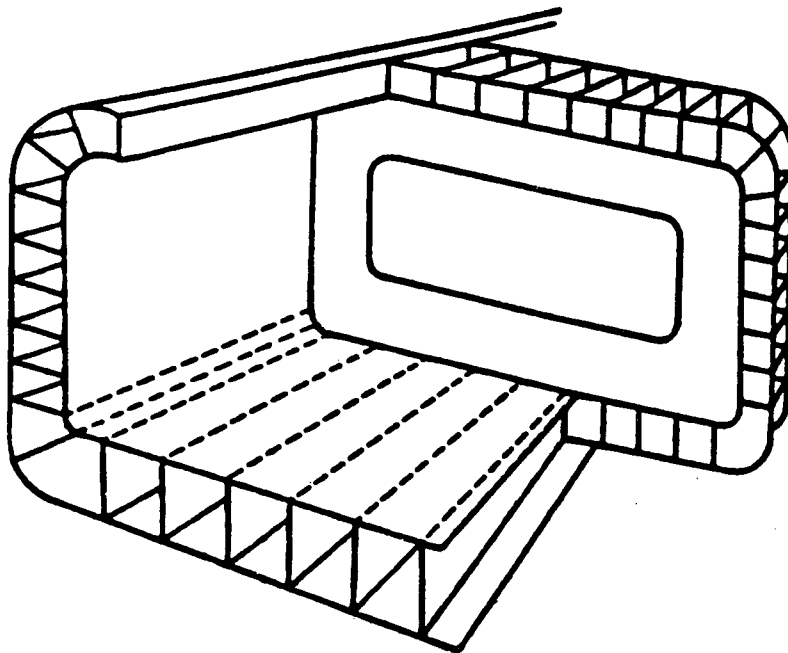

FIGURE 3.4
 UNIDIRECTIONAL DOUBLE HULL
 STRUCTURAL SYSTEM.

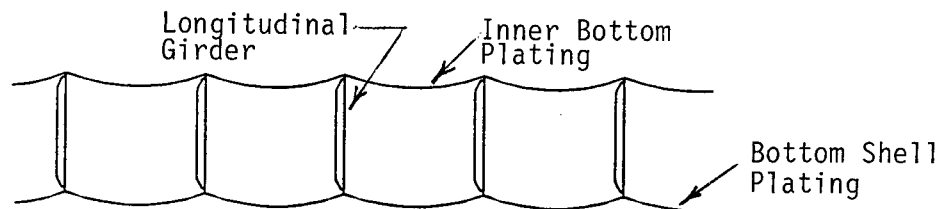

FIGURE 3.5
 DISHED PLATE UNIDIRECTIONAL
 DOUBLE HULL STRUCTURAL SYSTEM

3.3 RESULTS

Table 3.2 provides concepts for improved producibility which can be utilized in identifying structural elements for double hull tankers which exhibit the desired improvement.

Table 3.2: CONCEPTS FOR IMPROVED PRODUCIBILITY

A. Maximize areas of flat plate

Continue parallel midbody as far forward and aft as possible, replacing curved plate with flat as far as practicable.

B. Maximize areas of single curvature and developable surfaces for remaining shell plating, including bow and stern.

Compound curvature of plating to be avoided wherever possible.

C. Maximize frame or longitudinal spacing

Increase frame or longitudinal spacing as far as practicable to obtain an efficient structure with fewer piece parts. A balance between heavier structure and benefits from this concept will have to be reached. Maximize web frame and longitudinal spacing without the plate thickness requiring additional weld passes.

D. Maximize ease of fit-up and accuracy of construction configuration

Endeavor to provide block breakdown that provides ease of fit up and associated increased accuracy of construction. Employ statistical accuracy control for producing parts subassemblies, blocks and for all hull erection work.

E. Maximize stiffener cross-section efficiency

Maximized stiffener cross-section efficiency will provide the least weight. In addition if a structural piece is made up of a number of sections, care in their arrangement will not only give the most efficient structure but will facilitate fit up. Maximize use of flat bar stiffeners; use angle bars, tee bars or bulb flats elsewhere. Where angle bars are used, endeavor to vary only the web depth and use the same flange width with the varying web depths. Use smallest variations in bar stock size practicable.

F. Maximize producibility friendly structure

This is structure that when properly arranged will facilitate the erection process due to self-supporting and self-aligning characteristics. This also means that hull blocks will be defined that are stable when they are upside down and when they are right-side up in order to facilitate preoutfitting and painting.

G. Maximize applicability to automatic devices and robotics.

The structure should be arranged as much as possible to take advantage of automatic devices and robots for welding, painting, and inspection, although this will require the structure to be built to finer tolerances.

H. Maximize plate forming compatibility

Arrangement of seams can facilitate the efficient forming of plate in areas of compound curvature, e.g. arrange seams so that both ends of plate have approximately the same curvature.

- I. Maximize use of standardization of parts and procedures
 - (a) Standardize brackets, stiffeners etc.
 - (b) Standardize construction blocks as far as possible.
 - (c) Use of process lanes.
- J. Optimize the weights and sizes of blocks to be transported for the purpose of facilitating work flow.
Maximize weights and sizes of blocks commensurate with lifting capacity at the building berth.
- K. Minimize the total number of piece parts required.
- L. Minimize weight without sacrificing producibility
Do not increase the number of piece parts while minimizing weight.
- M. Minimize fatigue effect of structural detailing while improving producibility.
Try to minimize fatigue without sacrificing producibility.
- N. Minimize welding
One sided welding, use of robotics, prefabricated pieces. Minimize fitting and welding lengths for subassembly, block assembly and erection work.
- O. Support pre-outfitting
Provide as much pre-outfitting as possible in blocks and outfit modules, including painting on block. Devise block shapes that provide good access for pre-outfitting, (including electric-cable pulling), and painting and that facilitate handling by cranes and/or transporters.
- P. Support machinery packaged outfit module development
For machinery space, pump rooms, etc.
- Q. Minimize staging
Possibly through use of structure that is self supporting and by performing work when blocks are upside down.
- R. Maximize maintainability without compromising producibility.
Plan for flat surfaces which will shed cargo, i.e. easy or self-draining surfaces.
- S. Maximize automatic welding
Some foreign shipyards may incorporate 60% of semi-automatic or automatic welding. Endeavor to plan blocks for its maximum use. Participate in the development of lightweight automatic welding devices for preferred structural configurations vice being just depended upon what welding machine manufacturers have available.
- T. Maximize the dual use of structural components
e.g. Bulkheads below deck supporting above-deck foundations, and substituting square steel tubing that can serve as vent ducts for H-beams that support engine room flats.

The list of concepts for improved producibility provided in Table 3.2 have been utilized to identify candidate structural elements including components, material, processes, shipyard facilities or design features, as shown in Table 3.3 below.

Table 3.3: STRUCTURAL ELEMENTS

Element

1. Extra wide plating to reduce the number of welded seams.
2. Tapered plating.
3. High percentage of single curvature plate at forward and aft ends.
4. Reduced numbers of piece parts in structural assemblies.
5. Built up plate piece vs. single plate with cut-outs (e.g. lower wing tank web)
6. Corrugated or swedged plating - see Figure 3.6.
7. Rolled vs. built up sections.
8. Fabricated stiffeners and girders (possibly of two strength materials) vs. rolled section
9. Stringers - to facilitate construction and aid inspection.
10. Use of bilge brackets in lieu of longitudinals in the bilge turn area.
11. No longitudinals in bilge turn area and bilge brackets negated due to thicker shell plating.
12. Longitudinal girders without transverses.
13. Standardized plate thicknesses in inventory. Establish limiting plate thickness to avoid weight gain from transition thickness plate.
14. Standardized stiffener sizes in inventory.
15. Standardized structural details (good producibility and weldability together with low failure rate).
16. Standardized equipment and foundations.
17. Coiled plate - Presumably in rolls and would be available in longer lengths.
18. Stiffened elements fashioned from one frame space width of plate with stiffener formed on one side - see Figure 3.7.
19. Double bottom floors and girders lugged and slotted into bottom shell and inner bottom for easier alignment. Similar technique could be used in wing tanks and on double plate bulkheads etc. - see Figure 3.8.

Materials

Limit steel grades used to those which do not present problems with welding, fatigue due to less than optimum detailing, etc.

Processes

1. Use of a product work breakdown structure which identified interim, i.e. in-house products.
2. Statistical analysis of in-process structural accuracy variations.
3. Employment of statistically obtained data to anticipate shrinkage caused by flame-cutting and welding operations.
4. Automatic and robotic welding.
5. Automatic and Robotic painting.
6. Automatic and robotic inspection.
7. Numerically-controlled flame cutting.
8. Line heating both for creating required curvature and for removing distortions in process.
9. Standardize welding details.
10. One-sided welding.

Use of Shipyard Facilities

1. Optimize block size to suit shipyard transporter and crane capacities.
2. Optimize structure to suit shipyard panel line and other facilities.

Design Features

1. No dead rise, camber or sheer.
2. Standardized stiffener spacing.
3. Standardized double skin separation (keep same in all size vessels if feasible).
4. Standardized aft end design - engine room, mooring etc.
5. Standardized forward end design - mooring, anchoring etc.
6. Standardized transition of double skin to single skin.
7. Formed hopper corner knuckle - see Figure 4.1.
8. Flat deckhouse sides and ends.
9. Standardize deck heights to minimize number of different heights.
10. Standardize size and type of closures, scuttles, and accesses to the smallest variation practicable.
11. Align and locate all sanitary spaces to simplify piping.
12. Collocate spaces of similar temperature characteristics to minimize insulation requirements.
13. Locate access openings clear of erection joints to allow pre-installation of closures.
14. Provide specific material coating and equipment preferences and reasons for preferences i.e. types of pumps, pump locations, equipment makers, coatings, materials, cable types, cable trays, piping arrangements, valve types, valve locations, windlass arrangements, hose arrangements, etc..
15. Structural trunks for cables and pipes (lower tween deck height is then possible).
16. Design risk and possible failure should be considered when proposing new structural or outfit concepts.

Structural Arrangements

1. Longitudinal framing with formed hopper side corner and corrugated bulkheads.
2. Unidirectional stiffening supporting inner and outer shells.
3. Dished plate unidirectional hull, wherein the added strength due to the curvature in the shell and other plating increases the resistance to deformation and buckling and therefore permits decreased thickness of plating for a given spacing of girders.

Table 3. indicates those structural elements applicable to existing shipyards as set forth in Table 2.3. Table 3.5 indicates those alternative elements applicable to a notional shipyard as set forth in Table 2.4.

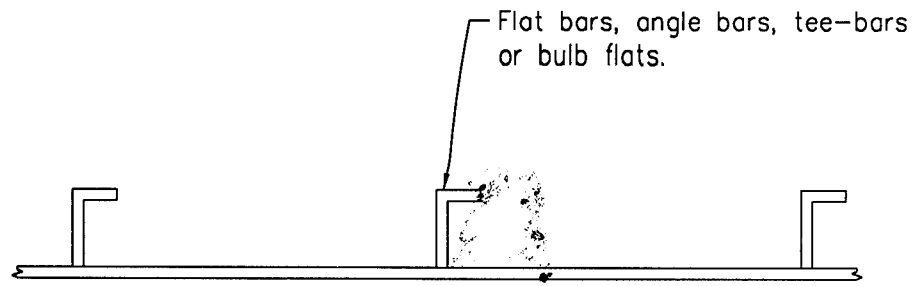

(a) Conventional Stiffening

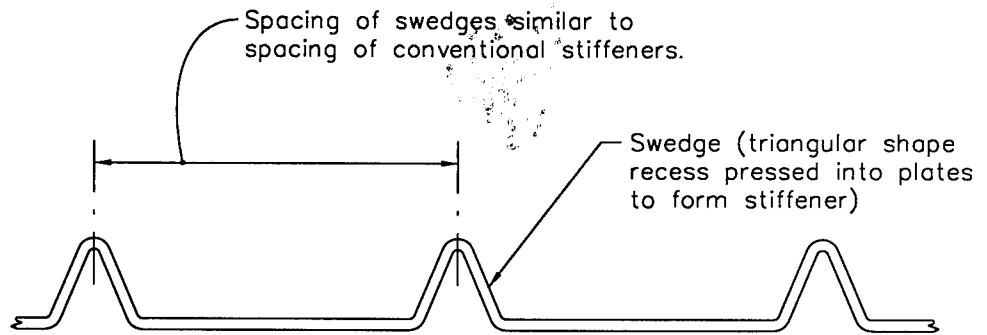

(b) Swedged Plating

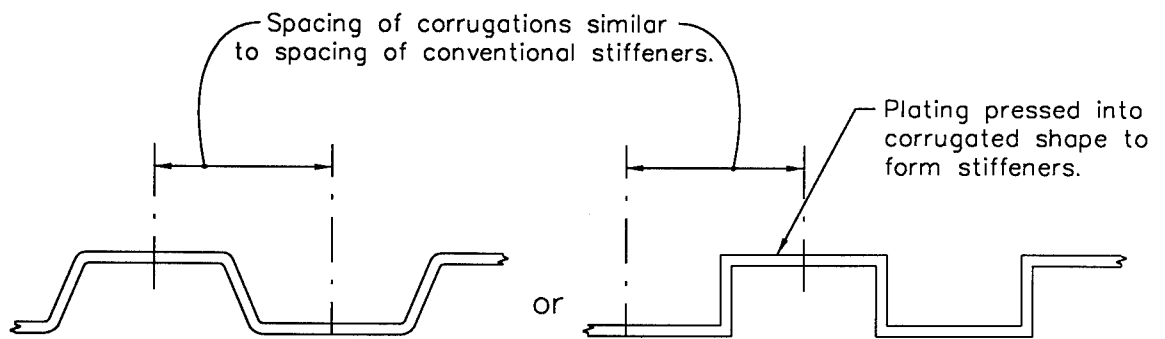

(c) Corrugated Plating

Figure 3.6
ALTERNATIVE METHODS FOR STIFFENER PLATING

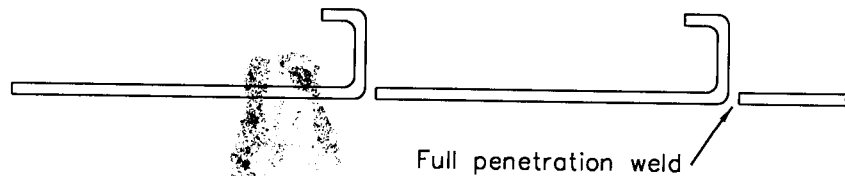

Figure 3.7

STIFFENED ELEMENTS FORMED FROM ONE FRAME (OR STIFFENER) SPACE WIDTH OF PLATE WITH STIFFENER FORMED ON ONE SIDE.

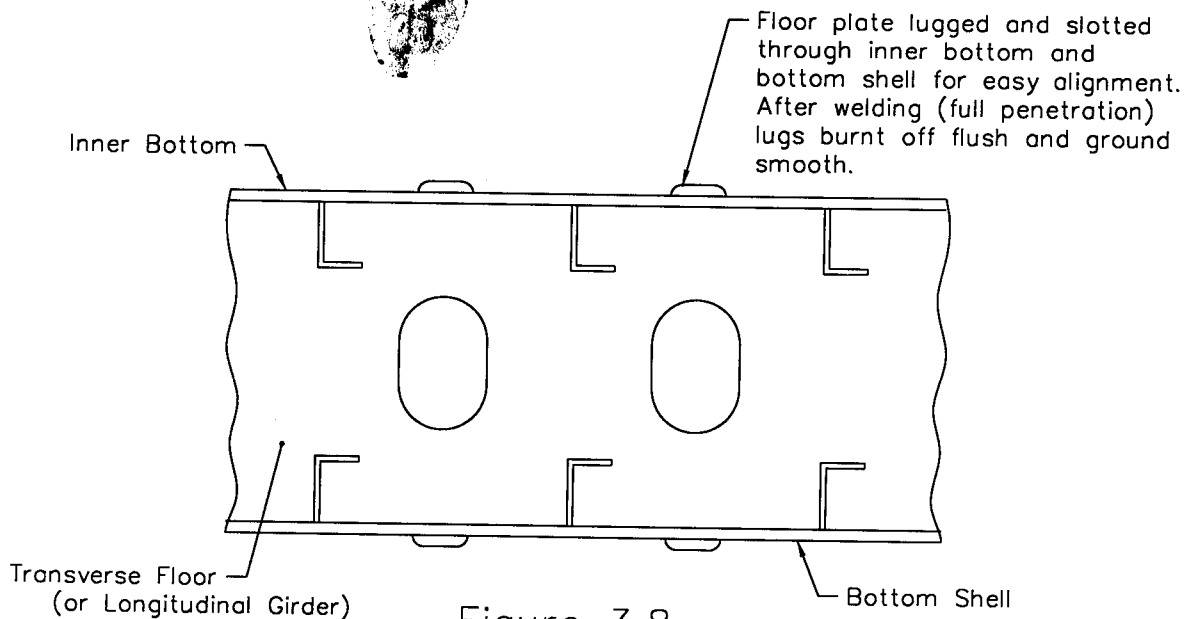

Figure 3.8

LUGGED AND SLOTTED STRUCTURE

NOTE: With the structure depicted in Figure 3.7, there may be problems with small bending radii in thick plates, full penetration welds in every frame or stiffener space, locked in stresses, and maintenance problems due to the large number of shell penetrations.

With the structure depicted in Figure 3.8, there may be problems with cutting away longitudinal material, stress risers, fatigue and cracks.

**Table 3.4: STRUCTURAL ELEMENTS
APPLICABLE TO EXISTING U.S.
SHIPYARDS**

- Rolled vs. built up sections.
- N/C hull penetrations.
- Line heating.
- Maximum block size to suit capability of shipyard facilities.
- Maximum length of blocks to suit steel availability.
- Reduced numbers of piece parts in structural assemblies.
- Rounded gunwale.
- Internal webs of upper wings and hopper from traditional web frames to plate webs.
- Ends of stiffeners for floors simplified for production.
- Cargo area revised to yield identical tanks and therefore identical blocks.
- Cautious approach to use of high strength steels.
- Coating applied environmentally in sheds. 60% done in sheds, 25% on outfitting pier, rest in dock. Blasting w/ steel and 80% re-usable copper grit.
- Pre-installation of access closures.

**Table 3.5: STRUCTURAL ELEMENTS
APPLICABLE TO A NOTIONAL
SHIPYARD**

- Standardized accuracy.
- Standardized modular/zone construction (Interim products).
- One sided welds
- Structure optimized for use with builder's process lanes and other facilities.
- Standardized size and type of closures to smallest variation practicable.
- Standardized design details.
- Single curvature longitudinals.
- Developable surfaces.
- Cheaper to change structure to make it more friendly to automation at a fraction of cost of robotics.
- Unidirectional vessel blocks are as long as practical considering crane capacity.
- Engine room block size to 800t.
- Deckhouse 60% outfitting done before lifting on board.
- Deck piping 80% done before lifted on board.
- Standard statistical analysis of structural accuracy variations.
- Robotic welding. (Note - see "cheaper" above)
- Robotic inspection.
- Robotic painting and touch up.

4.0 TASK III - ALTERNATIVE STRUCTURAL SYSTEM CONCEPTS

4.1 OBJECTIVE

The objective of this task is to synthesize the structural elements discussed in Section 3.0 into alternative structural system concepts based on their apparent potential for improved producibility. These then become the candidate alternative system concepts to be utilized in the remaining tasks.

The nature of the alternative structural concepts selected is to be such that their principal characteristics are sufficient to establish the entire structural concept for a tanker. That is, they are to include shell, inner hull, shell stiffening, inner bottom, deck, subdivision bulkheads and other primary hull structure. Some aspects of the alternative concepts may be similar to those already utilized in tanker construction, as these have proven effective. On the other hand, even previously adopted concepts may offer opportunity for optimization as, for example, in the number of structural pieces or processes employed in their fabrication.

4.2 APPROACH

In order to assemble the structural elements identified in Task II into alternative structural system concepts for a double skin tanker, they were first grouped into categories associated with the components of the structural, machinery and outfitting systems, as shown in Table 4.1.

**Table 4.1:
COMPONENTS AND ELEMENTS OF
STRUCTURAL SYSTEMS**

<u>Hull Form</u>	<u>Tank Arrangement (in addition to double skin)</u>
Flat surfaces	No CL or wing bulkheads
Developable surfaces	CL bulkhead (oil tight or non-tight)
Compound curvature	Wing bulkhead P/S
No bulbous bow	
Cylindrical bulbous bow	<u>Machinery</u>
Bulbous bow with compound curvature	Single screw slow speed diesel
Cylindrical bow	Single or twin screw medium speed diesels
Single screw stern	
Single screw stern with bulb	<u>Pumping System</u>
Twin screw stern	Variable
<u>Deckhouse</u>	<u>Rudder</u>
Block configuration	Horn type
Straight sides and ends	Spade type
Flat decks	
	<u>Shell</u>
	Smooth plate
	Dished plate

Table 4.1 continued

Shell and Deck Longitudinals

None
Flat bars
Angles
Tees
Bulb flats
Rolled vs fabricated sections
Unidirectional system

Deck

No sheer
No camber
Parabolic camber
Straight line camber with C.L. knuckle
Straight line camber with knuckle P/S
Single vs double skin

Main Bulkheads

Stiffened Plate
Corrugated
Double Plate

Girders

Stiffened plate
Swedged plate

Plate

Flat
Swedged
Corrugated
Dished

Inner Hull Connection to Inner Bottom

Bracketed
Sloped hopper
Sloped hopper with formed corners
Radiused corner (unidirectional designs)

Main Deck/Sheer Strake Connection

Square (sheer strake extends above deck)
Radiused

Blocks

Number of blocks
Size and weight

Blocks Cont'd.

Structural complexity
Number of pieces
Shoring, pins or jigs
Number of turns

Material

Mild Steel (MS)
High Strength Steel (HSS)
Combination (HSS/MS)

Welding

Manual
Automatic
Robotic

Plate Forming

Rolling
Pressing
Line Heating

Accuracy

Normal standard
High standard

Shipyard Facilities

Cranes
Transportation
Automation
Material throughput
Process lanes

Structural Details

Standard
Specialized/Fitted

Coatings

Pre-construction primer
Standard quality
High quality

Design

Standardization

Maintainability, Strength and Fatigue

Accessibility
Smooth surfaces
Structural intersections.

In order to maintain a manageable number of alternatives and facilitate an objective producibility comparison, some elements and components had to be selectively considered on a subjective basis. This was accomplished as follows:

1. **Hull Form** - Hull form should be based on the principles of developable surfaces, with compound surfaces avoided except for minor areas such as those at the forward and after ends of the bilge turn. This provides for simpler and more accurate production of curved plates by rolling in one direction, [11]. The bow portion of the 40KDWT alternatives has been assumed to have a cylindrical bulbous bow. The 95KDWT alternatives have been assumed to have a cylindrical bow (no bulb), since such a bow at block coefficients above 0.825 has been shown to reduce power requirements at 15 knots for the size of vessels considered herein, [12], versus the typically shaped bow and bulb with compound curvature. The stern is configured as a conventional single screw vessel without bulb. There has been some consideration of a twin screw configuration for a "get us home" redundancy, but this would be an owner's option.

As the alternative structural concepts are basically of the same configuration, the effect of the ship's end structure on labor hours will be similar with the exception of the dished plate unidirectional alternatives. The transition from dished to flat and curved plate at ends is a unique feature of these vessels, but the effect on labor hours was considered to be small.

2. **Deckhouse** - The deckhouse is located aft and should be of block configuration with straight sides and ends. To support producibility, the decks should have no camber and be of uniform height between decks. Decks should be continuous with the structural bulkheads (including outboard bulkheads) intercostal. This requires a small piece of each deck to project outside the peripheries of the house to provide space for fillet welds. This will improve producibility, since pre-outfitting and painting can be accomplished on upside-down blocks prior to erection of the complete deckhouse. Structural bulkheads may have swedged plate stiffeners.

The machinery casings on the weather deck and the stack should form a structure separate from the main deckhouse, so that the latter can be completed without interference from machinery space related work.

3. **Tank Arrangement** - Owner preference and the results of stability studies have favored a centerline bulkhead for the sizes of vessels considered herein. Two longitudinal bulkheads with no centerline bulkhead have been utilized for the larger VLCC's, but are not considered here. The centerline bulkhead may be omitted or be tight or non-tight, leading to two or one cargo tanks across, depending upon stability requirements. One of the 40KDWT alternative structural concepts has no centerline bulkhead, for comparison purposes. The wing tanks and double bottom tanks are port and starboard ballast tanks.

4. **Machinery** - A single screw slow speed diesel has been used for the baseline ships as a representative option. As the sterns of the alternative structural concepts are of basically similar configuration, the effect of differences in machinery pre-outfitting and machinery/piping package units on producibility can therefore be assumed small and neglected.

5. **Pumping System** - This is a variable that will depend on owners preference, products carried or production considerations. There may be a pump room or deep well pumps. Pumps may be electric or hydraulic. For study purposes, all alternatives were assumed to have a pump room with similar pumping and piping arrangements, cargo piping on deck and ballast piping run through a tunnel in the double bottom.

6. **Rudder** - The horn rudder is the predominant type provided for tankers. It is characterized by a large horn casting or weldment with a gudgeon and pintle. On the other hand, the spade rudder does not include these characteristics, although the rudder stock will be larger. The anticipated improved producibility of the spade rudder supports its being utilized despite the larger stock.

7. **Shell** - Both smooth shell and dished shell were considered for the alternative structural concepts. The dished shell provides additional strength as a result of its curvature.

8. **Shell and Deck longitudinals** - Shell and deck longitudinals may be flat bars, angles, tees or bulb flats. Large flat bars are often installed at the main deck as a means of reducing deck plate thickness. They are easier to install than other sections, but very large flat bars require significant welds at butt joints. The unidirectional hulls, both smooth and dished plate, have no longitudinal stiffeners in the conventional sense of the word, but are framed longitudinally with plate girders joining the inner and outer shells. The longitudinal plate girders are supported by the transverse bulkheads, with no intervening transverse webs.

Tee sections are more desirable than angle sections from the viewpoint of structural stability and fatigue. Also, although they are harder to paint, it is understood from various owners that there is not much trouble with them in pooling of cargo. Therefore, tee sections were considered to be a viable alternative to angle sections.

For the conventionally framed vessels, bulb flats have advantages when considering surface corrosion, cargo shedding, fit-up and painting because of less surface area and lack of flanges. However, they introduce problems at butt joints, due to difficulty in getting a satisfactory weld in way of the bulb. Considering strength, available bulb flats are generally too small for applicability to a vessel of 95KDWT, but recent information on jumbo bulb flats has become available (although physical availability is questionable) and bulb flats are therefore considered for both tanker alternative structural system sizes, notwithstanding the problem with butt joints.

Another consideration is the need to fabricate sections as their size increases past the available rolled section level. Recent advances in welding technology, laser, and high frequency resistance welding have decreased the distortion associated with fabricated sections, although these new welding technologies have not as yet made significant inroads into shipbuilding practice, [13]. However, for all sizes of sections, all but bulb plates were considered fabricated in the yard, with the welding of stiffener flanges to webs accounted for in the evaluations of weld length and volume. Comparisons between rolled and fabricated sections can be found in consideration of alternative structural concepts for both 40K and 95KDWT vessels with bulb flats and similar concepts constructed with fabricated angles and tees. The impact of rolled vs. fabricated sections on labor hours and schedule can be gleaned from these comparisons.

In summary, one conventionally framed structural alternative of each vessel size is stiffened entirely with bulb flats. The remainder of the conventional alternatives have tees on the bottom shell and inner bottom, angles on the side shell and flat bars on the deck, so that all available section shapes have been used. Also, as described in Section 5.4, an additional range of stiffener sizes was incorporated in one alternative structural concept for both 40K and 95 KDWT vessels.

9. **Deck** - Sheer or camber of weather decks is undesirable from a producibility point of view, and sheer has been generally eliminated from large cargo vessels. It has therefore been eliminated from the vessels under consideration. Camber has been retained since its lack would allow pooling of water on deck. However, parabolic camber has been replaced by the more producible straight line camber having a central flat portion with port and starboard knuckles.

With regard to a single vs. double skin main deck, it appears that the double deck has been generally avoided in the design of double hull tankers, due to its impact on vessel dimensions and cost. However, it was noted that some of the proposed unidirectional designs, [7] [8] [9] [10], have opted for a double skin at the deck, so as to continue the double envelope with its longitudinal girder system across the deck. Therefore, the alternatives considered are a single skin deck for conventional double skin tankers and a double skin deck (tight or non-tight inner deck) for the unidirectional designs. It may be noted that a double deck provides a convenient location for a pipe tunnel for cargo piping, should this be considered desirable.

10. **Main Bulkheads** - Main transverse bulkheads have been constructed from plate and vertical stiffeners in the conventional double hull alternatives, with the exception of vertically corrugated bulkheads with top and bottom stools on one 40K and one 95KDWT alternative, for producibility comparisons. Centerline bulkheads have also been constructed from plate and longitudinal stiffeners. With regard to the corrugated bulkhead option, such bulkheads are not necessarily the bulkheads of choice due to reported problems with cracking in service, although they are preferred by some owners for their cargo shedding property as compared with conventional bulkheads. Corrugated bulkheads may also provide some producibility advantages. The unidirectional and dished unidirectional plate alternatives have been constructed with vertically corrugated bulkheads, conventionally stiffened bulkheads with horizontal stiffeners and double plate bulkheads.

11. **Girders** - A swedged girder may be described as one in which the web plate stiffeners are formed by pressing swedges (see Figure 3.6) into the web plate in lieu of fitting flat bar or angle bar stiffeners. However, swedged girder webs are not used (particularly for primary structure), since it is believed that the accordion like swedging will not allow the web to develop the full shear transfer capabilities that a flat plate would develop.

12. **Plate** - The option between stiffened and swedged plating is not viable for the primary structure of a vessel. However, swedged plating can be used for miscellaneous bulkheads and deckhouse bulkheads. Corrugated plating is applicable to main or miscellaneous bulkheads. Dished plating is a feature of the dished plate unidirectional concept.

13. **Inner Hull Connection to Inner Bottom** - This alternative is concerned with the form of the outboard lower corners of the cargo tanks. "Bracketed corner", "sloped hopper", "sloped hopper with formed corners", as shown in Figure 4.1, have all been considered from the standpoint of producibility. This alternative component is largely in the hands of the designer and owner, and there may be a noticeable but perhaps small difference in producibility. The unidirectional alternatives have rounded corner connections in these areas.

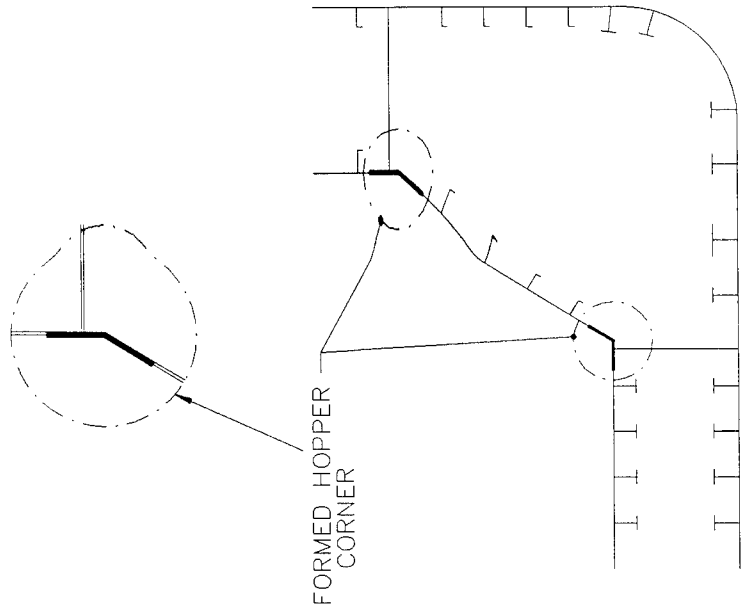

SLOPED HOPPER SIDE
W/ FORMED CORNERS

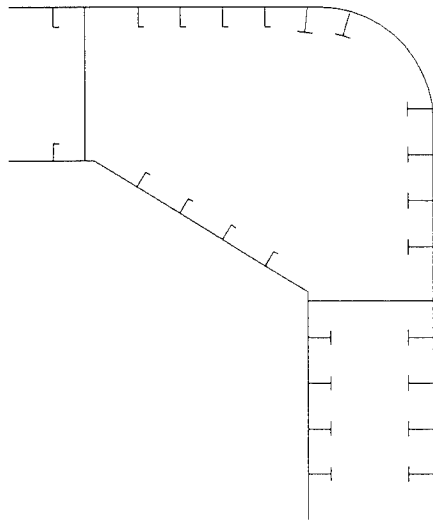

SLOPED HOPPER SIDE

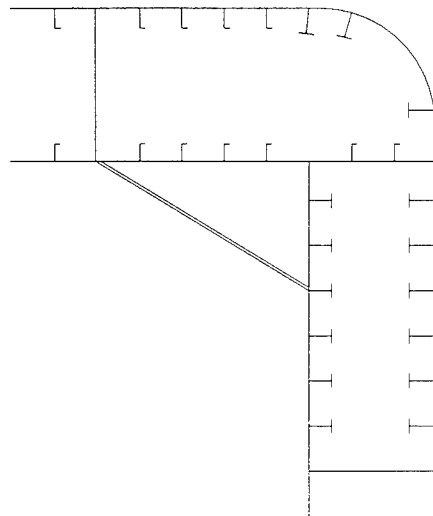

BRACKETED

FIGURE 4.1 - TYPES OF LOWER HOPPER CORNERS

14. **Main Deck/Sheer Strake (Gunwale) Connection** - This is usually a square corner, with the sheer strake extended a short distance above the deck plating. Alternatively, a radiused corner may be fitted for the purpose of alleviating stress concentration. Since the square corner generally requires less labor hours than the radiused type, it has been adopted as standard for the various alternatives, with the exception of the unidirectional vessels. Radiused gunwale connections are a particular feature of the latter designs.

15. **Blocks** - The breakdown of structural blocks was dictated by the use of a crane capacity of 75 tons. This was selected as a weight that can be easily handled throughout a U.S. shipyard facility capable of constructing the alternative designs. Although it was endeavored to keep the block size below 75 tons, some of the blocks exceed this throughout the alternative structural concepts considered. The heavier blocks were then considered as grand blocks to be handled on the building berths. From information reviewed concerning shipyard facilities, 150 tons can be handled on the berths by any U.S. facility large enough to produce the alternative structural concepts.

A potential reduction of 11% in labor hours was reported by Hills et al [14] for a reduction of blocks in the midship section of a RO/RO vessel from nine to three, and a similar savings was reported by Bong et al [15] for a reduction of blocks in the midship section of a bulk carrier from eight to four. Although these savings are applicable only to the construction of the midship portion of these vessels (one block length), it is apparent that block size should be maximized to suit yard facilities.

The need for shoring, pins or jigs in the construction of blocks depends upon their structural complexity and the amount and shape of curved plating. The need for turning blocks over depends upon types of welding processes used, lifting arrangements, etc. For example, the use of one sided welding on a flat plate structure removes the need for turnover of such a unit. Such considerations are typically the same for all of the structural alternatives considered, since the breakdown of blocks is the same throughout.

16. **Material** - As discussed in Section 2.5.2.2, it is considered that large conventional double hull tankers will be generally constructed with HSS (typically grade AH32) in the deck to the lower edge of the sheer strake, and in the bottom to the upper turn of the bilge. The unidirectional designs will be constructed of MS throughout. However, for comparative purposes, one 40K and one 95KDWT alternative have been constructed of MS throughout and one 40KDWT unidirectional alternative has been constructed with a combination of HSS and MS as above.

17. **Welding** - There is a wide range of welding considerations - manual, automatic, robotic, one sided welding, the type of welding process, welding position, etc. Such considerations and their application to the structural alternatives are addressed quantitatively in Section 6.0. Typical U.S. shipyard welding facilities have been assumed as a baseline.

18. **Plate Forming** - The choice of rolling, pressing or line heating for forming plating depends largely on the nature and complexity of the required shape or curvature, whether it be simple (one-directional), conical or compound. As indicated in Section 6.0, only the midship portions (one tank length) of the various structural alternatives have been evaluated for producibility. Thus, the only plate forming required for the majority of these consisted of the corrugated bulkhead plating (by pressing) and the curved bilge shell plating (by rolling). The dished plate unidirectional alternatives provide the only exception, where a large quantity of plating required rolling or pressing to the desired curvature.

19. **Accuracy** - In the process of building ships, it has long been known that in manufacturing components in accordance with design drawings, the dimensions of these components may vary to an extent that adjustments have to be made during the construction process to arrive at the vessel depicted in the design. These adjustments can include a significant amount of re-work, including trimming of excess material, inserting additional material, pulling, straightening and bending structure to suit alignment, and in some cases discarding components which are too distorted to be reasonably utilized. The setting of accuracy goals and the understanding of the actual accuracy attainable in various manufacturing processes in the shipyard has been identified as a means of pre-determining some of the aforementioned problems and to avoid them by adjustments during the manufacturing process.

Although this matter has always been of importance in shipbuilding, it is probably more critical in modern shipbuilding techniques utilizing Product Work Breakdown Structure (PWBS) as units, blocks and complex modules are erected and a multitude of systems need to fit together. This is opposed to the older systems approach to ship construction where simultaneous interconnection at one time of many systems or components of the same system did not occur.

In order to address accuracy control, the NSRP has compared accuracy levels measurement such as those contained in NSRP 0371, [16]. This reference provides data on the cutting of individual pieces for fabrication and on the fabricated components themselves. It is interesting to note from this data that the U.S. shows some superiority over Japan in the cutting of components, whereas the reverse is true for fabricated components. This may be due to the fact that most shipyard cutting is accomplished by numerically controlled equipment which is available world wide, whereas fabrication requires control of many other processes. This suggests that the Japanese have a better control of accuracy on fabricated components.

This also suggests that the Japanese followed the Pareto principle for prioritizing their methods development. They recognized that for hull construction typically about 5% of work-hours are required for parts cutting, 50% for sub-assembly and block-assembly, and 45% for hull erection. Thus, they first focused on statistical accuracy control and line heating as means to reduce the work hours associated with the large percentages. This ultimately led to the need to provide shrinkage compensation both for flame cutting and for subsequent welding operations. In contrast, shipyard managers elsewhere focused on the least amount of work hours with N/C cutting and ultimately direct computer control of cutting machines. They continued to look for devices to force fits without significant drop in sub-assembly, block assembly, and hull-erection work-hours, without improvement in safety, and with the continuance of locked-in stresses.

The most modern approach which has been taken to achieve accuracy control in shipbuilding is termed "Statistical Accuracy Control." In this procedure, the manufacturing processes throughout the shipyard are closely monitored, dimensional data of components is collected and a data base established. This data is then statistically analyzed and based on the mean dimensions and standard deviations exhibited by any repetitive production process, adjustments are made to the "designed" dimensions of components so that "adjusted" dimensions can be used in the production process to enable components to be produced having dimensional characteristics that are within anticipated mean values and variance. The process, when applied to all the various components throughout the vessel, can result in a pre-determined knowledge of the ultimate dimensions of the entire vessel within the combined mean dimensions and standard deviation of its parts. Further adjustments can then be made such that the dimensional characteristics of each of the components can be defined for the construction process and fabrication can proceed to these specific dimensions with the confidence that the results will be

within an acceptable tolerance level. This will result in all components fitting together to form the complete vessel without the need for expensive and time-consuming rework. The practice of incorporating additional material into components, to be trimmed later as necessary, can be virtually abolished, since all material can be cut to a predetermined tolerance.

Accuracy control is not considered as a separate structural alternative herein, but the amount of rework assumed for alternatives is identified in Section 7.0. Reduction of this rework by greater accuracy control will be self evident in the results presented in that Section.

20. **Shipyard Facilities** - The production inputs including shipbuilding policy, facility dimensions and capacities and interim product types (blocks) were selected in a manner that can be accommodated by existing U.S. shipyards. As an example, crane lifting capacity was limited to 75 tons for individual blocks and 150 tons for grand blocks.

The importance of identifying the entire production strategy cannot be over emphasized. When utilizing advanced shipbuilding systems, a general yard practice is to carry out extensive study and evaluation prior to finalization of the basic hull block breakdown to assure that the best compromise of fabrication cost, block erection and outfitting cost is achieved. Also, the use of large multi-system machinery/piping package units is one of the most significant improvements in ship construction methods and these units have to be defined as well. These decisions should be made very early in design for production.

21. **Structural Details** - Specialized/fitted structural details are considered time consuming in design and fabrication. On the other hand, the use of standardized structural details eliminates design and can save time in fabrication and are therefore more producible. In order to obtain a comparison, two alternative choices were selected. Specialized/fitted structural details have been taken as indicating the norm and standardized structural details have been taken as indicating the option supporting higher producibility, although details have not been specifically identified.

22. **Coatings** - Coating choice can be complicated by many factors, including owners preference, yard capability, quality, etc.. The selection of coatings is usually more closely tied to the level of maintenance acceptable to the owner. Although this will not be explicitly considered herein, the type of coating system used will also depend upon whether the alternative system concept is constructed of mild steel or high strength steel. The latter will be thinner than the equivalent mild steel and may therefore require superior coatings to provide adequate corrosion resistance.

Coatings are also complicated by the need to have a weld-through pre-construction primer that will be satisfactory as a base for the next paint coat together with a fast enough work flow so that the primer is sufficiently intact when the next coat is applied. Otherwise there must be complete blasting and painting rework. It can be seen therefore that the primers are an important consideration in producibility.

23. **Design (Standardization)** - An important aspect of Japanese shipyard productivity is that tanker design has been totally standardized. Unfortunately, it takes a great amount of effort and experience to obtain the standard design, and it is highly unlikely that the first go around on the ship design would be suitable for use as a standard without exceptional effort.

For example, Ishikawajima-Harima Heavy Industries Col, Ltd. (IHI) exploits a very flexible approach to standardization. For a so called standard ship, even hull blocks can vary

significantly while achieving the benefit normally associated only with a standard design that must be rigidly followed. They employ group technology, wherein manufacturing characteristics are emphasized. As long as the distribution of work does not change significantly, insofar as the shipbuilding system is concerned, a standard ship is being produced regardless of the design differences. Regarding engine-room outfitting, IHI employs four basic machinery arrangements. Two are for different low speed and two are for different medium speed main diesel engines. For each auxiliary machine position in an arrangement, two or three different vendor catalog items are certified as shipyard standards. The items are functionally equivalent but physically different. For the purpose of declaring vendors' equipments as shipyard standards, preference is given to those vendors who each produce machines of the same basic design for a range of capacities. Thus, each standard machinery arrangement can expand or contract with engine horsepower. Therefore, IHI's standards system offers options that can be negotiated during contract design and provides for more than one vendor's equipment for each application in order to insure competitive pricing. IHI has been able to incorporate the standards in its Future-Oriented Refined Engineering System for Shipbuilding Aided by Computer (FRESCO). FRESCO also features separation of engine room fittings into module assemblies with companion diagrammatics modularized the same way [17].

Due to standardization, there is no need for preliminary design, design studies or component selection. Everything has already been determined from midship section to main engine selection. The makes and models of equipment to be used are known, and there appears to be a loyalty to suppliers. The most extreme case of the latter occurs when a shipyard has a product license. For example, if a shipyard is licensed to build a particular engine, all ships from that shipyard will be powered by those engines.

Even drawing numbers are standardized. If the Inert Gas System diagram on one ship is numbered PAZ0031, then it is numbered PAZ0031 on every ship they build, no matter how it differs. The name of the appropriate ship is all that appears on the drawing to distinguish it from other drawings. This procedure saves significant time in obtaining drawing numbers, references and correct schedules. In Japan, they never change and it is obviously very time saving when preparing control documents such as drawing schedules. One drawing schedule can be used for any ship with minor modifications.

A minimal number of final drawings is provided to the owner. For example, HVAC, piping and electrical diagrams are provided, but detail routing/arrangements are not. In the accommodation spaces, even the diagrams do not indicate the quantity and location of fixtures. Deck, machinery space and pump room piping arrangements are prepared, but are not provided to the owners as final drawings. However the diagrammatics are quasi arranged and supplemented with whatever information is needed for regulatory approvals and for use by operating engineers.

The ship drawings are the same on each vessel. Basically they are a standard drawing with minor modifications. For example, all diagrams are basically the same. As a comparison, consider the labor hours and time required to design and prepare the diagram for a cargo oil system, and then estimate the labor hours and time required to change an existing diagram to suit say an increase in the number of tanks. If the discharge rate was also to be increased, the next standard pump size could be selected and the pipe sizes (also standard) changed to suit.

Similarly, the main engine cooling water system on different ships would not change if they all had the same engines and auxiliary equipment. For the next engine size, it would only be necessary to increase pipe sizes and some quantities.

Once the drawings are completed there are few revisions, compared to the large number encountered in the U.S.

Even the vendor drawings are standardized. An engine control console remains essentially the same for each of the main-engine types maintained in the shipyard's file of flexible standards. For each particular console there is apt to be at least two vendors, not more than three, for competitive pricing. Only vendors who adopt the same flexible approach are so listed. Thus their vendors' operations are regarded as extensions of the yard's shipbuilding system.

When Japanese managers participate with an owner in negotiating a contract design they typically offer a design that they believe will fulfill the owner's requirements. At the same time, they may have available options for altering their initial offer all of which, because of their use of group technology, are consistent with their shipbuilding system. Furthermore, it appears they prefer to keep contract changes to a minimum to avoid any impact on production.

However, they do accept changes provided work classifications per group technology logic and work amounts do not substantially change so that the scheduled launch date remains unchanged. Otherwise there would be deleterious impact on other construction projects. After launch, they would entertain any change the owner is willing to pay for and would, if necessary, employ subcontractors and/or rent a pier, so that there is no adverse impact on the cadence of their shipyards work flows.

As a result, Japanese shipyards have files of flexible standards which detail everything in work instructions. It is therefore plausible that the level of design labor hours can be as low as 50,000, as indicated in Section 5.3.3

As discussed in Section 7.0, 200,000 and 225,000 design labor hours have been assumed for 40K and 95KDWT tankers building in the U.S., starting from a preliminary design and ending with working drawings. In the absence of a standard design, this scenario will also impact the phased material procurement and places some risk on the construction schedule, in that as the design progresses and equipment and material are identified, there is no guarantee that issuing purchase orders at that time will result in delivery to the shipyard to support construction in a timely manner.

As a means of comparison for identifying schedule impact, a structural alternative has been assumed where some design standards exist and less design material is required by the shipyard workers. In this case, 100,000 labor hours have been assumed for design.

24. Maintainability, Strength and Fatigue - The proper application of effective coatings is an important aspect of maintainability. Double hull tankers have an advantage regarding the coating of cargo oil tanks in that the internal structure of the tanks is free of longitudinals and transverse stiffening except for under deck and bulkhead stiffeners. Even greater advantage is possessed by unidirectional vessels with a double skin deck and in some cases, double plate bulkheads. Cargo tank cleaning is also simplified on double hull tankers.

With regard to the coating of water ballast tanks contained within the double hull, the unidirectional alternatives have a further advantage of smoother surfaces and greater accessibility, due to the longitudinal girder system. It should be noted, however, that effective accessibility is dependent upon suitable spacing of the girders. In the conventional double hull tankers, the water ballast tanks are framed with longitudinal stiffeners which are difficult to coat, and are therefore more subject to corrosion, particularly in the bottom of the tanks.

Steel renewals due to corrosion, on a long term basis, would therefore appear to be more likely in the conventional alternatives than in the unidirectional vessels.

In addition, the nature of the unidirectional hulls, where relatively thick plating is required for the hull and tank envelopes, dictates that the available hull girder strength is well above typical classification society requirements. This results in the longitudinal hull envelope steel operating at lower induced stresses than the more conventionally framed alternatives, with consequent longer fatigue life for structural components.

With regard to structural connections, the simple intersections of bulkheads and girders on the unidirectional alternatives provide a detail more preferable from a fatigue viewpoint than the typical intersections of longitudinals, webs, floors and bulkheads on the conventionally framed alternatives. A significantly greater number of possible fatigue areas, operating at higher longitudinal operating stresses, render the conventionally framed alternatives less desirable than the unidirectional vessels from a fatigue viewpoint.

4.3 **RESULTS**

A series of alternative structural system concepts has been synthesized from the components and elements shown in Table 4.1. Each alternative consists of 24 components or elements generically depicted in Table 4.2. As can be seen, of the 24 components or elements, eleven are directly varied, while the remainder are in accordance with the baselines described in Section 4.2. The complete set of structural alternatives is described in Section 5.0.

Table 4.2: GENERIC ALTERNATIVE STRUCTURAL SYSTEM CONCEPTS

<u>COMPONENT OR ELEMENT</u>	<u>CHARACTERISTICS</u>
1. Hull Form	Baseline Sect. 4.2 - item 1
2. Deckhouse	Baseline " " - item 2
3. Tank Arrangement	Per Alternative
4. Machinery	Baseline Sect. 4.2 - item 4
5. Pumping System	Baseline " " - item 5
6. Rudder	Baseline " " - item 6
7. Shell	Per Alternative
8. Shell and Deck Longitudinals	Per Alternative
9. Deck	Baseline Sect. 4.2 - item 9
10. Main Bulkheads	Per Alternative
11. Girders	Baseline Sect. 4.2 - item 11
12. Plate	Per Alternative
13. Inner Hull Connection to Inner Bottom	Per Alternative
14. Main Deck/Sheer Strake (Gunwale) Connection	Baseline Sect. 4.2 - item 14
15. Blocks	Baseline Sect. 4.2 - item 15
16. Material	Per Alternative
17. Welding	Per Alternative
18. Plate Forming	Per Alternative
19. Accuracy	Baseline Sect. 4.2 - item 19
20. Shipyard Facilities	Baseline " " - item 20
21. Structural Details	Per Alternative
22. Coatings	Baseline Sect. 4.2 - item 22
23. Design (Standardization)	Per Alternative
24. Maintainability, Strength and Fatigue	Baseline Sect. 4.2 - item 24

5.0 TASK IV - APPLICATION TO SPECIFIC DOUBLE HULL TANKERS

5.1 OBJECTIVE

The objective of this task is the application of the alternative structural system concepts identified in Section 4.0 to 40K and 100KDWT Jones Act double hull tankers to investigate the potential for improved producibility in the U.S. A further objective is the estimation of baseline construction schedules and labor hours for these vessels.

5.2 SELECTION OF BASELINE VESSELS

The statement of work for this project required the application of the alternative structural systems to tankers of 40K and 100KDWT for the U.S. Jones Act trade. The 40KDWT vessel would likely be a product carrier or a shuttle crude carrier. The 100KDWT vessel would likely be a crude carrier only. Furthermore, it is desirable that a baseline vessel be identified which has been built in a foreign shipyard under a recent building schedule.

The Jones Act trade has made use of tankers of approximately 40KDWT over the years, although they have been rarer in the international market with vessels in the 30K+ and 54KDWT sizes being more prevalent. The 100KDWT size range tanker has also been used in the Jones Act Trade. Foreign vessels in this size range are generally just under 100KDWT and of the "Aframax" type.

As a result, the following procedure was adopted:

- A vessel resembling a 95KDWT 1993-95 vintage Far Eastern built crude carrier was adopted as the baseline vessel. The general arrangement and midship section are shown in Figures 5.1 and 5.2 respectively. The principal characteristics are given in Table 5.1.
- A foreign design example for the 40KDWT vessel was not available. Accordingly, a hybrid was prepared utilizing the generic features of the 95KDWT Far Eastern vessel and principal characteristics indicated by previously built 40KDWT tankers for the U.S. Jones Act trade. The general arrangement and midship section are shown in Figures 5.1 and 5.3 respectively. The principal characteristics for the vessel are given in Table 5.1.

Table 5.1: BASELINE DOUBLE HULL TANKER PRINCIPAL CHARACTERISTICS

	<u>40KDWT</u>	<u>95KDWT</u>
Length B.P. (LBP)	183.00M	234.00M
Breadth B	31.00M	41.50M
Depth D	17.70M	19.75M
Design draft	11.28M	13.75M
Block Coefficient C _b	0.80	0.83
SHP	8,500	13,000
Displacement	52,790MT	114,280MT
Lightship	12,790MT	19,280MT
Wing Tank Width	2.20M	2.70M
Double Bottom Depth	2.20M	2.20M
Cargo Tanks	7@ 17.90M	7@ 25.06M

The unidirectional hulls have slightly different dimensions to suit assumed proportions of the structural cells in the double skin, as shown in Table 5.2, but cargo capacity is essentially the same as that of the baseline vessels.

Table 5.2: UNIDIRECTIONAL DOUBLE HULL ALTERNATIVES

<u>95 KDWT</u>	<u>U1</u>	<u>U2</u>	<u>U3</u> (Dished Plate)
Breadth B	40.75M	41.8 M	40.4M
Depth D	21.0 M	22.4 M	21.2M
Wing Tank Width	2.0 M	2.2 M	2.2M
Double Bottom Depth	2.6 M	2.2 M	2.2M
Bottom Girder Spacing	1.75M	1.15M	2.4M
Side Girder Spacing	1.45M	1.15M	2.4M
Deck Void Depth	1.0 M	2.2 M	2.2M
<u>40 KDWT</u>	<u>U4</u>	<u>U5</u>	<u>U6</u> (Dished Plate)
Breadth B	30.5 M	30.85M	30.8M
Depth D	17.57M	19.35M	18.8M
Wing Tank Width	2.0 M	2.2 M	2.2M
Double Bottom Depth	2.6 M	2.2 M	2.2M
Bottom Girder Spacing	1.75M	1.15M	2.4M
Side Girder Spacing	1.45M	1.15M	2.4M
Deck Void Depth	1.00M	2.2 M*	2.2M

*open to cargo space

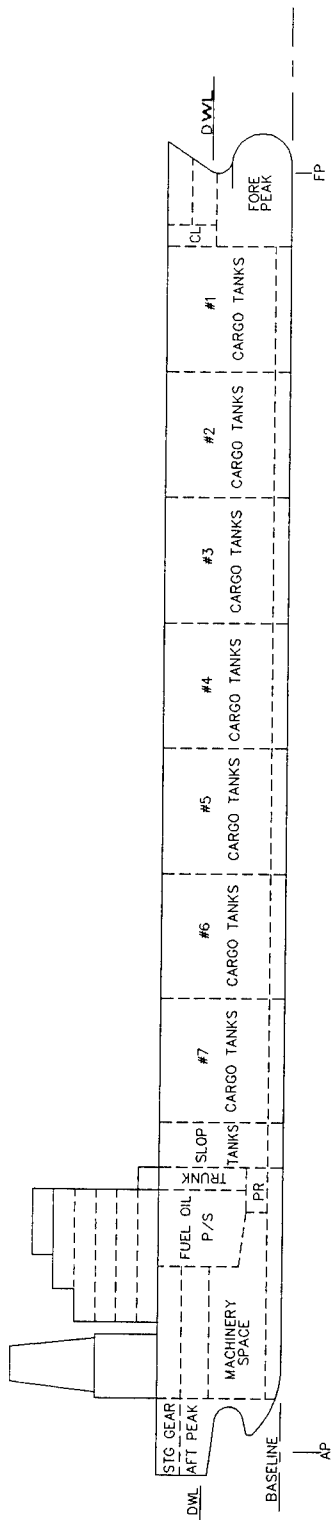

40K DWT DOUBLE HULL TANKER
LBP= 183 METERS

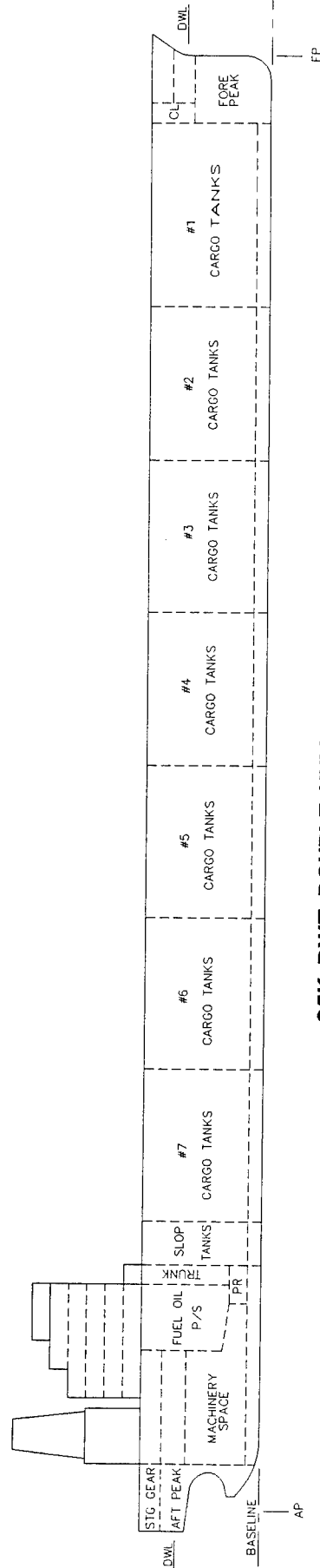

95K DWT DOUBLE HULL TANKER
LBP= 234 METERS

FIGURE 5.1 - GENERAL ARRANGEMENTS

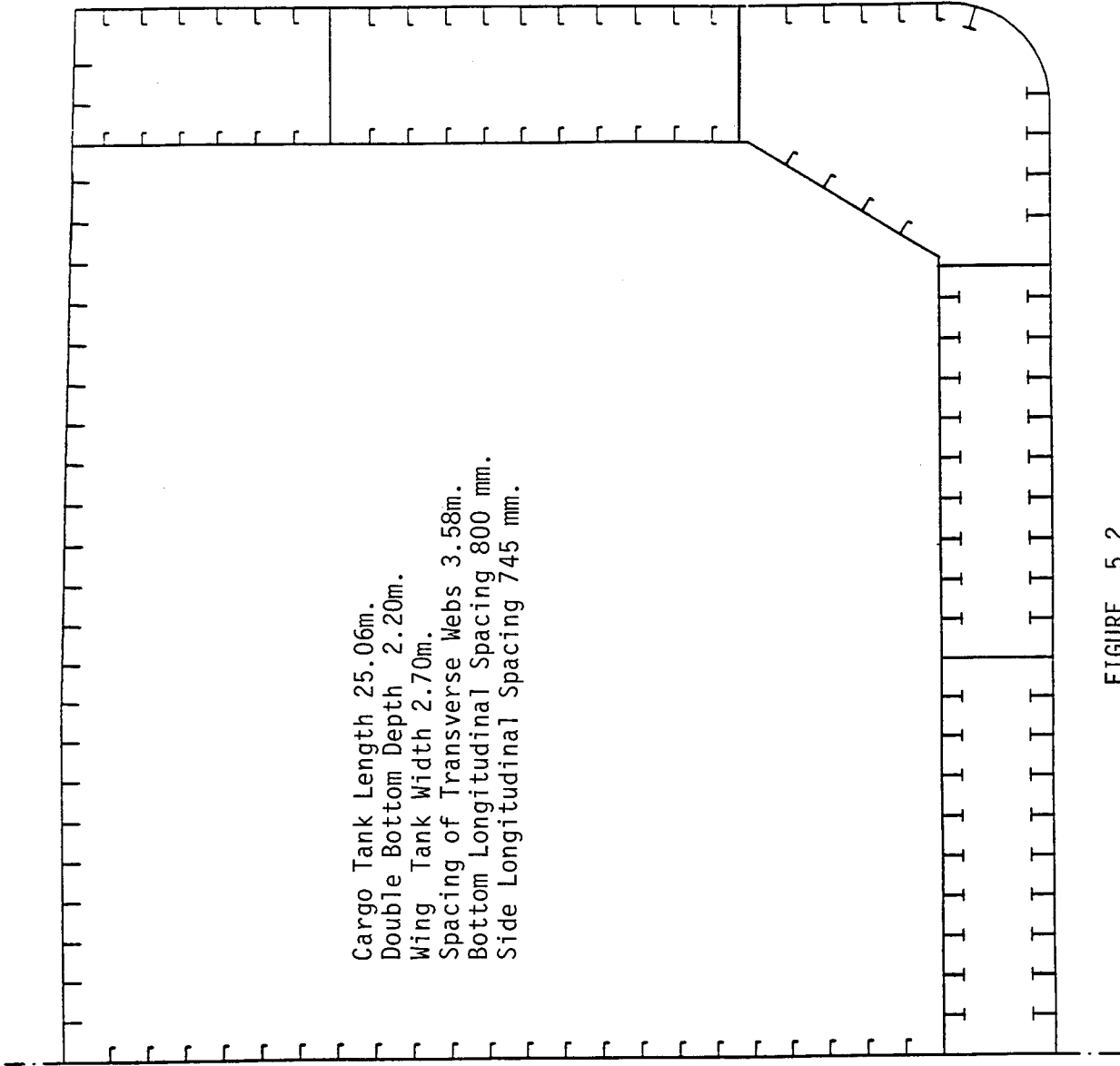

Cargo Tank Length 25.06m.
 Double Bottom Depth 2.20m.
 Wing Tank Width 2.70m.
 Spacing of Transverse Webs 3.58m.
 Bottom Longitudinal Spacing 800 mm.
 Side Longitudinal Spacing 745 mm.

FIGURE 5.2
 95KDWT BASELINE MIDSHIP SECTION

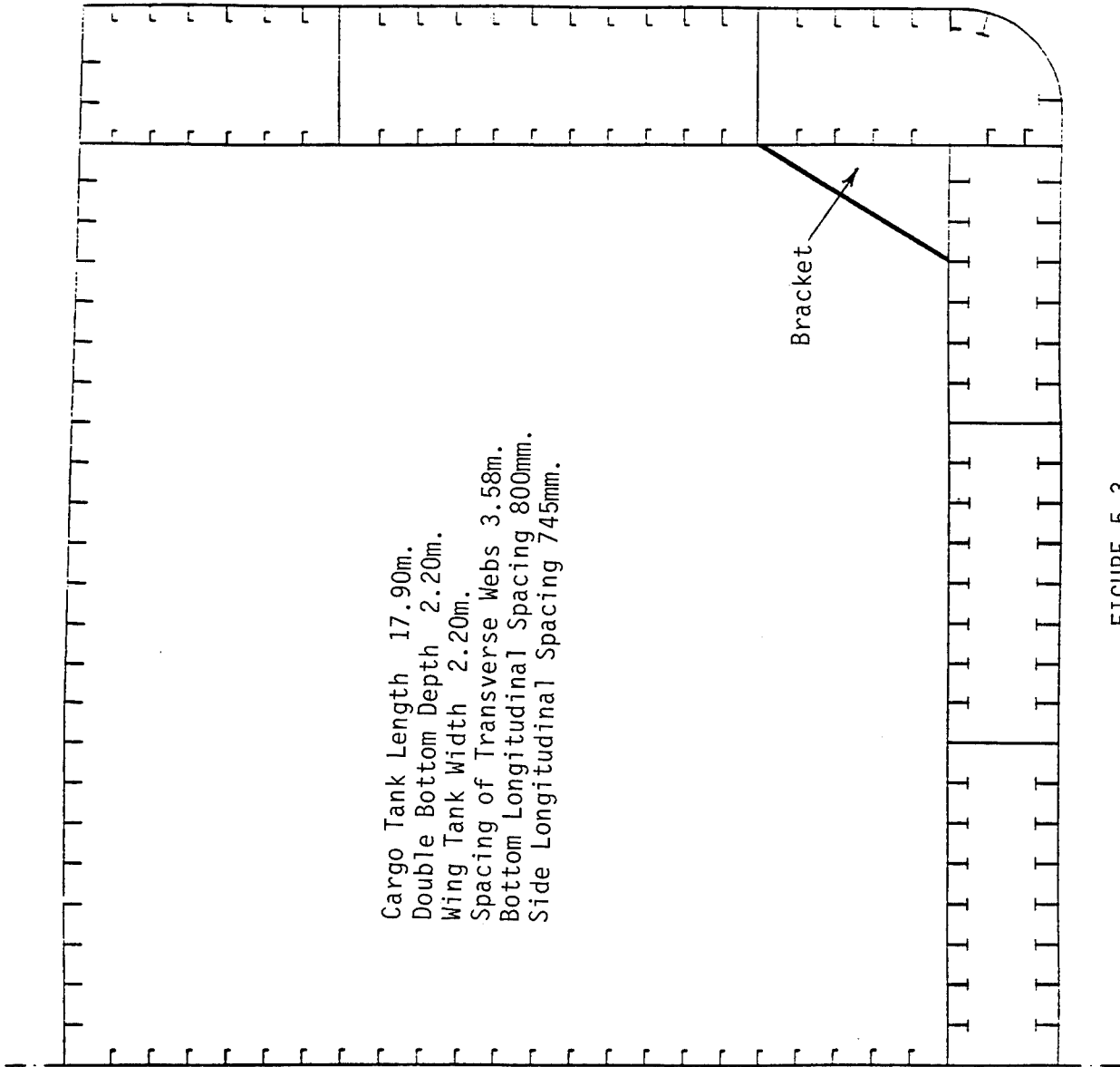

FIGURE 5.3
40KDWT BASELINE MIDSHIP SECTION

5.3 BASELINE CONSTRUCTION SCHEDULES AND LABOR HOURS

5.3.1 General

This Section provides highlights of schedule and labor hour data obtained from the survey described in Section 2.5, and projections made therefrom.

5.3.2 Construction Schedules

The importance of time in terms of schedule on ship cost has been addressed in Section 1.0. Typical schedules of construction, distribution of labor hours as well as actual labor hours, were sought in the literature, from shipowner experiences and through foreign shipyard contacts. Pertinent information was received from all sources on shipbuilding schedules and distribution of labor hours. However, virtually no current information on actual labor hours was obtained, presumably due to its proprietary nature.

Construction schedules have been identified from the sources noted above. Figure 5.4 shows examples for several types of vessels constructed in the U.S. and abroad, indicating months from start of fabrication to launch. Fabrication is defined as commencement of steel cutting.

Figure 5.5 indicates two schedules from contract to delivery for constructing double hull tankers. These schedules are for a Danish yard (84KDWT) [18] and a Japanese yard, [18]. Note that the total schedules from contract signing to delivery are 22 and 20½ months respectively.

5.3.3 Labor Hours

Figures 5.6 and 5.7 are U.S. versus Japanese comparisons of hull and machinery/outfitting work for the PD 214 general mobilization vessels, [20], which have the characteristics of containerships and roll-on/roll-off carriers, both of which are more complex than tankers. They provide estimated labor hours between the U.S. and the Japanese. Note that these vessels were not built. The total labor hours for design and construction of the vessels was estimated to be 710,000 hours in Japan and 1,834,000 in the U.S. for the first ship. One would expect that the design engineering would be greater than indicated (about 50,000 hours) for the Japanese yard. All that can be said is that for design engineering, production engineering and mold loft, the projected Japanese effort is 20% of the labor hours of the U.S. yard. This low figure is undoubtedly due to the extensive collection of standards and modules in computerized design systems that are integrated for design, material, and production functions. These are employed like building blocks and many automatically adjust in size during detail design commensurate with different capacities, [21].

Table 5.3 shows a 1992 comparison [22] of labor hours and period required for delivery of the first 80KDWT tanker after contract for an average U.S. shipyard and a typical Japanese shipyard. It indicates that the U.S. is superior in outfit and piping construction, but inferior in design techniques, casting techniques and production control. Although the data compares an average U.S. shipyard and a typical Japanese shipyard, no justification is offered for the large differences in the numbers, nor is it clear if the values are applicable to 1992. As shown, the labor hours are 594,000 for the Japanese and 1,374,000 for the U.S. yard. (Note: the reference indicated the U.S. labor hours as 2,374,000, which is believed to be a typographical error.)

Table 5.4 assesses the impact of technologically advanced shipbuilding techniques on labor hour requirements and shipbuilding cycle time, [23]. It is a comparison between an automated and a conventional yard in 1985, and indicates a 32% reduction in labor hours for the automated yard. In addition to labor hour savings, this effects a higher facility utilization (more throughput), resulting in higher return on investment capital. For this comparison, an automated yard is one in which investments have been made into increasing automation, i.e. automatic beam forming, cranes with pneumatic or magnetic lift, self traveling staging, welding, robots, etc.

It has been stated that: "Strict dimensional control of interim products through the different assembly stages is vitally important for profitable ship production, [24]. Studies in Finland show that a 30% reduction in labor costs is possible in hull construction, [25]. This reduction can be gained by eliminating unnecessary fitting and rework using tight accuracy control methods, [11]. Reference [26] indicates that large savings in labor hours and costs in Japan, as compared with U.S. shipyards, are due to scientific management methods, which include statistical control of manufacturing. The percentage of erection joints requiring no rework at a Japanese shipyard for a vessel in 1977 was 67.4%; in 1982, it was 75% for all types of ships, [27]. "Through organizational input... minimization of unnecessary rework through a proper accuracy control program.....can yield a typical potential increase in output of 15%," [28].

FIGURE 5.4

FABRICATION TO LAUNCHING TIME LINES

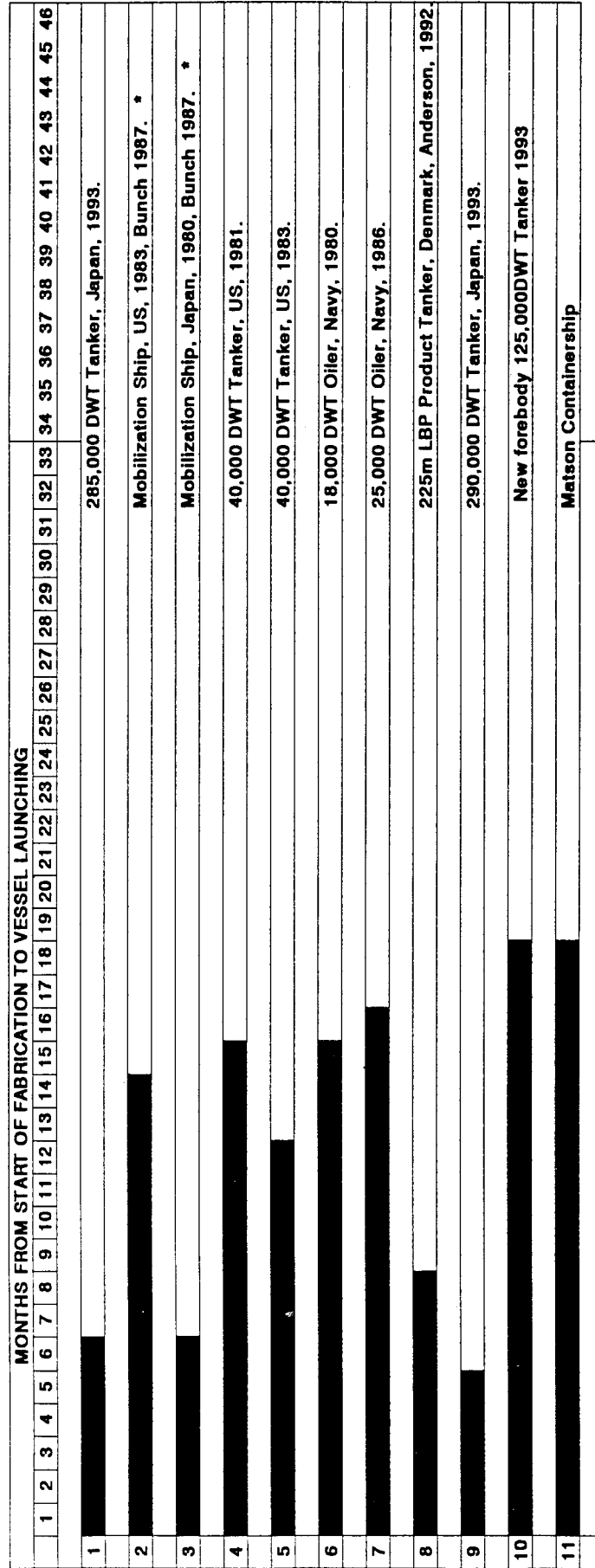

* Vessels not built

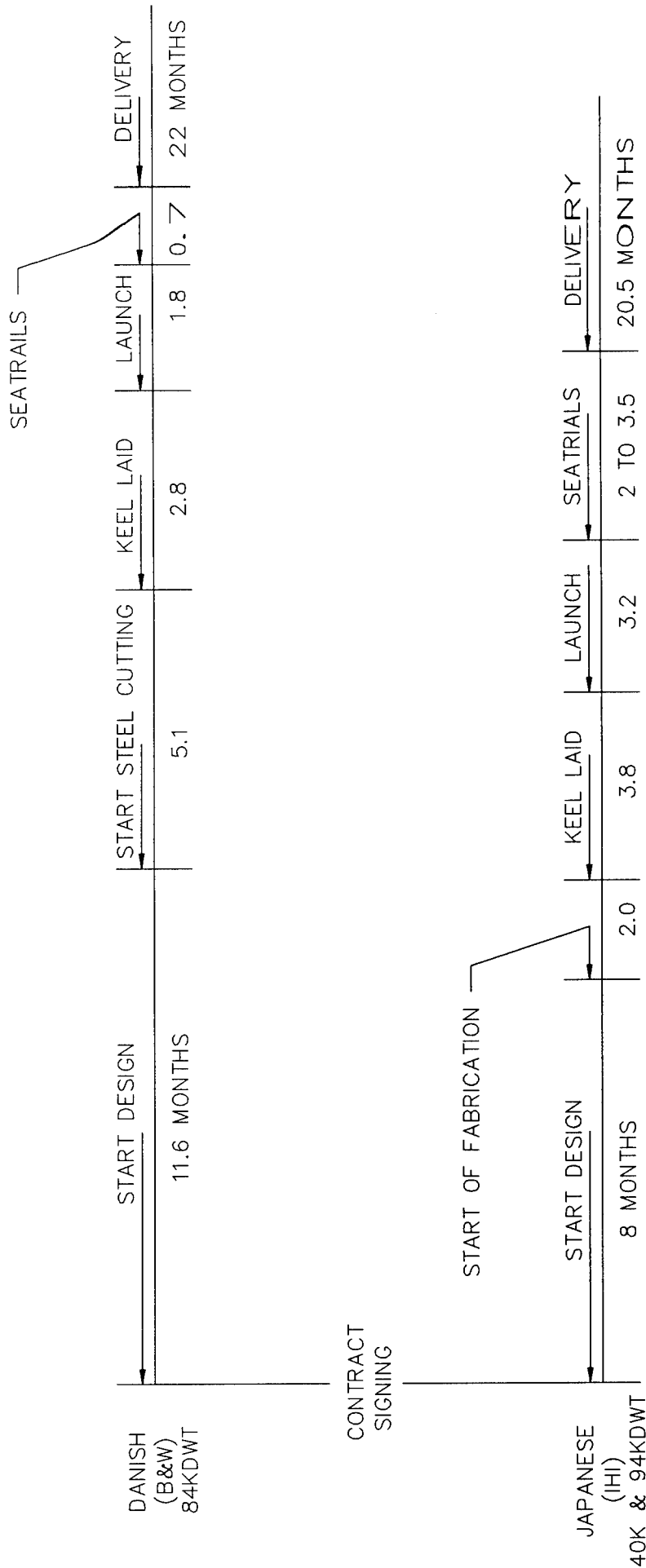

FIGURE 5.5

CONSTRUCTION SCHEDULE

FIGURE 5.6

HULL WORK LABOR HOURS, [20]

MARAD – U.S. vs Japan

PD-214 Estimate (early 1980's)

MARAD – U.S. vs Japan *
PD-214 Estimate (early 1980's)
Thousands of Laborhours

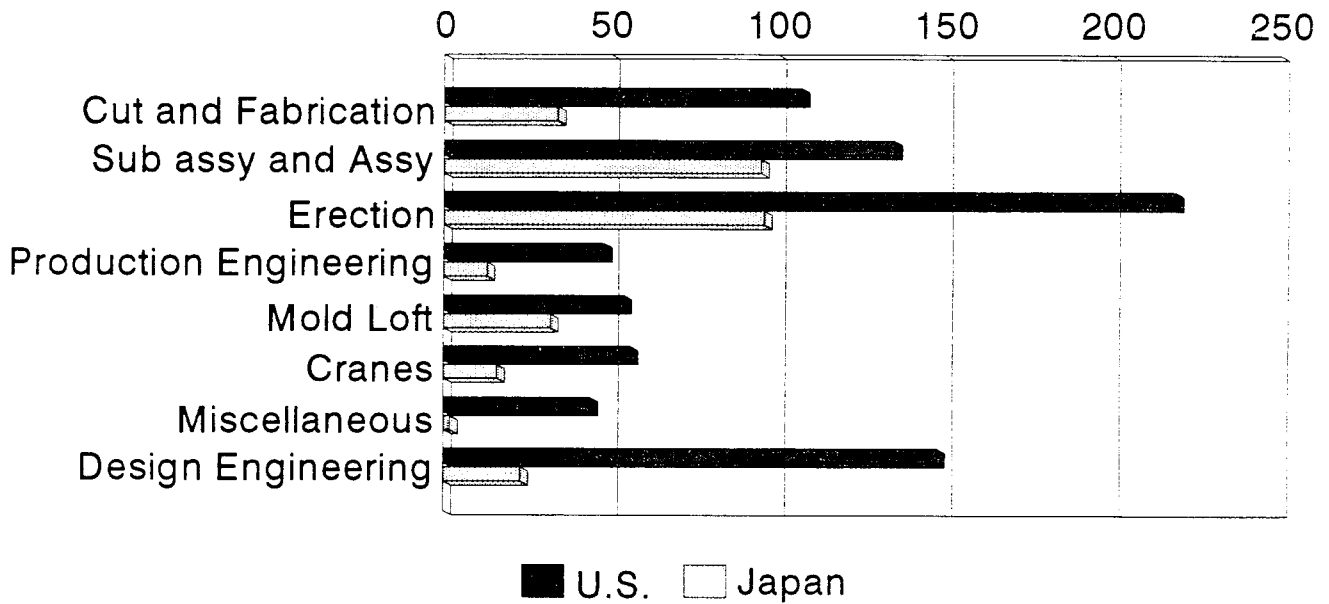

* Ships not built

FIGURE 5.7

MACHINERY/OUTFITTING LABOR HOURS, [20]

MARAD – U.S. vs Japan

PD-214 Estimate (early 1980's)

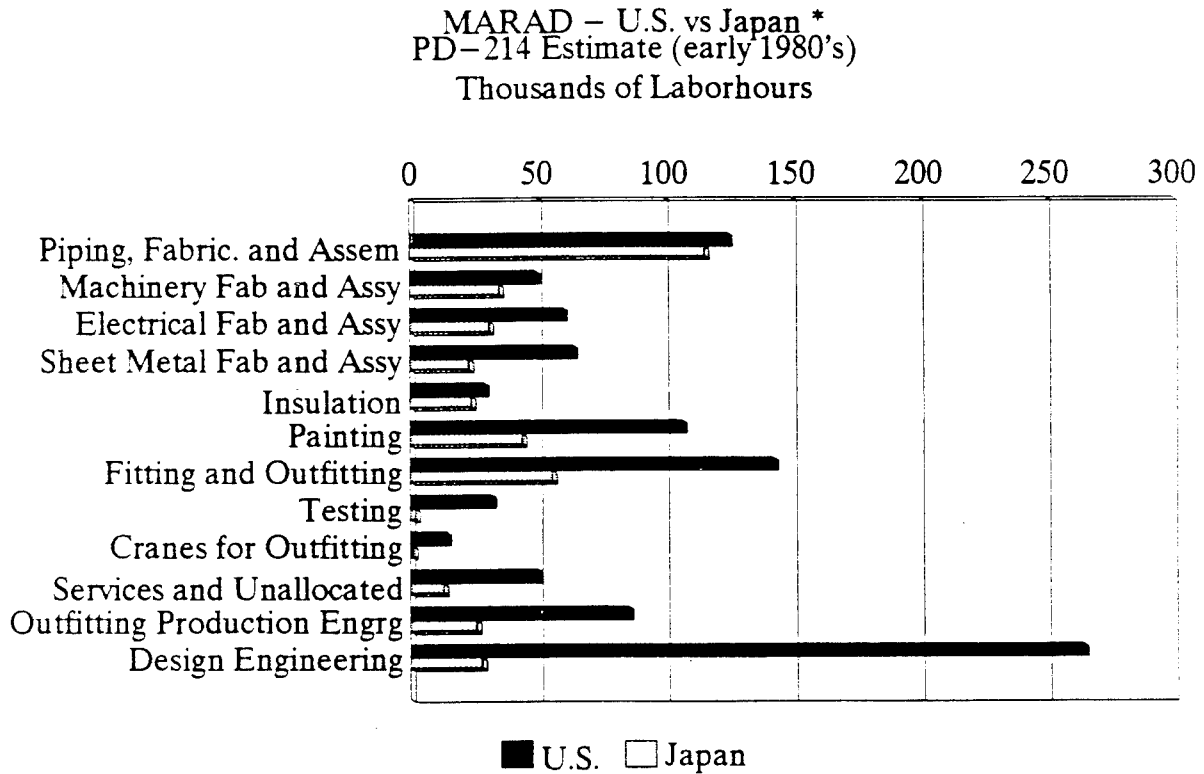

Table 5.3: COMPARISON OF PRODUCTIVITY (Baseline of 1.0 for Japan, unless otherwise specified) (1992), [22].

Item	U.S. ^a	Japan
Ships	Construction of five 80 000 dwt class tankers.	
Area of plant	2.5	1.0
Travel distance of materials	5.0	1.0
Number of built-up blocks	209	250
Period required for delivery of the first ship (after contract)	140 weeks (2.33)	60 weeks (1.0)
Labor hours for first ship	1,374,000 (2.31)	594,000 (1.0)

^a U.S. superior points: outfit, piping construction.

U.S. inferior points: designing techniques, casting techniques, production control.

Source: U.S. Maritime Administration.

Table 5.4: LABOR ALLOCATION (High-class cargo ship) (1985), [23].

	Labor % Automated Yard	Labor % Conventional Yard
Steel fabrication	3	4
Panel and shell	4	6
Outfitting:		
Electrical	4	4
Pipe	2	3
Machinery	4	5
Other	5	5
Subassembly	22	11
Block assembly	31	—
Ship erection	14	30
Launch	1	1
Post-launch outfit	<u>10</u>	<u>31</u>
	<u>100%</u>	<u>100%</u>
Total labor hours	68%	100%
Time required	54%	100%

Table 5.5 provides data for five single hull vessels built and delivered at IHI Yokohama Shipyard in the year 1972, [18]:

Table 5.5: DATA ON SINGLE HULL SHIPS BUILT AT IHI in 1972, [19]

<u>Type</u>	<u>Size</u>
OBO	224,070 dwt
Tanker	230,906 dwt
Tanker	227,778 dwt
Tanker	219,803 dwt
Tanker	232,315 dwt

The new construction of Table 5.5 was achieved with one building dock, supported by two 120-ton cranes and one 30-ton crane, [29]. The area of the yard used for such construction was just over 50 acres. According to Reference [19], the above vessels were constructed with a labor force of 1900, with 1150 employed on steelwork and 750 employed on machinery/outfit installation. A further 800 workers were employed on ship repair contracts. The work week consisted of 44 hours, with one shift per day and about 8 hours of overtime per worker per week. Since the five vessels were built in one year (say 50 weeks), then an average of 988,000 manhours per vessel was required for construction, excluding design hours.

Recent labor hour distribution data for construction of 40 and 95 KDWT double hull tankers in Japan was obtained from [19] and data for construction of an 84KDWT double hull tanker in Denmark was obtained from [18]. This data is summarized in Table 5.6 below. Tables 5.7 and 5.8 give the steel and outfitting breakdowns of Table 5.6.

Table 5.6: STEEL AND OUTFITTING RELATIVE LABOR HOURS FOR DOUBLE HULL TANKERS

	<u>Japanese*</u>	<u>Danish**</u>
Steel	55-63%	70%
Outfitting	45-37%	30%
	*IHI	**B&W

Table 5.7: STEEL LABOR BREAKDOWN FOR DOUBLE HULL TANKERS

	Japanese 40KDWT	Japanese 95KDWT	Danish 84KDWT
Parts Cutting & Bending	15%	14%	13.75%
Sub-assembly	13%	13%	12.75%
Assembly	45%	48%	45.25%
Erection	27%	25%	28.25%
Steel Total	100%	100%	100%

Table 5.8: MACHINERY/OUTFITTING LABOR BREAKDOWN FOR DOUBLE HULL TANKERS

	Japanese 40KDWT	Japanese 95KDWT	Danish 84KDWT
Machine Shop			2%
Pipe fab. and machinery pkgs.	11%*	10%*	10%
Pipe installation			21%
Misc. steel outfitting			17%
Hull & Accommodations	25%*	23%*	
Mechanical Installation			8%*
Joiners & carpenters			8%*
Machinery Outfitting	18%	16%	
Electrical Outfitting	9%	9%	16%
Tests & trials incl. Dry Dockg.	6%	8%	
Painting	31%	34%	18%
			Danish coating of cargo & WB tanks subcontracted
Outfitting totals	100%	100%	100%

*Affected by hull structural concept

To produce the Table 5.7 breakdown of steel labor hours, the original categories received from the Danish shipyard (steel processing, sub-assembly, flat and curved panels, blocks, erection, transport and riggers) were re-combined to better compare with those of the Japanese shipyard so that a meaningful comparison of labor hours could be made. Note that the Danish coating of cargo and water ballast tanks were subcontracted. It can be seen that if this item is added into the Danish total, then their outfitting percentage would increase and their steel percentage would decrease, possibly coming into closer agreement with the Japanese values.

If it is assumed from Table 5.6 that an average of 59% steel and 41% outfit breakdown in labor hours was consistent with Japanese production in 1972, then the 988,000 labor hours derived from Table 5.5 for single hull tanker construction in Japan would divide into 582,920 labor hours for steel and 405,080 labor hours for machinery/outfitting. Some support for

assuming identical distribution of labor hours in 1972 and 1994 can be gleaned from a consideration of the advances made in shipyard steel fabrication through automation, and at the same time the modular nature of some of the outfit delivered to a shipyard together with pre-outfitting. The above data can then be used to estimate the labor hours required in Japan in 1972 to construct 40K, 95K and 84K double hull tankers, and then to project the estimates to 1994.

For this purpose, it has been assumed that the total steel labor hours vary in some manner with the total weld length required for construction. To determine the relationship between weld length and vessel dimensions, a flat plate structural unit with longitudinals and transverse webs was first considered. The number of welds (butts and fillets) in the width w of the unit varies with plate width and the spacing of longitudinals, which both vary with w . Then the total length of welds varies with wl , where l is the length of the unit. Similarly, the total length of welds required for the transverse plate butts and webs (including face plates, etc.) varies with lw . Then the total length of welds for the complete unit varies with wl , i.e. the area of the unit.

To extend this reasoning to a ship, it may therefore be assumed that the total length of welds (and therefore the steel labor hours) in similar ships, with similar construction and block coefficients, varies approximately with an area numeral such as $L(B+D)$. For a better account of welding on main transverse bulkheads, a factor xBD may be added, where x is the number of bulkheads. For comparing ships with different internal arrangements however, such as single hull and double hull tankers, the numeral must be modified to take account of the inner bottom, the side tanks and any additional longitudinal bulkheads. Thus, for a single hull tanker with two longitudinal bulkheads and say ten transverse bulkheads, the numeral becomes $N_s = (2LB + 4LD + 10BD)$. For a double hull tanker with a center-line longitudinal bulkhead and ten transverse bulkheads, the numeral becomes $N_D = (3LB + 5LD + 10BD)$.

The average Japanese tanker deadweight in Table 5.5 was taken to be 228,000 tons (single hull) and estimated dimensions of the vessel were derived. The dimensions of the 84KDWT Danish double hull tanker were obtained from [18], while the dimensions of the 40K and 95KDWT double hull tankers are those given in this Section for the baseline vessels.

Table 5.9 was then prepared, providing a comparison of labor hours for the construction of tankers in Japan in 1972. The labor hours for construction of the 228KDWT single hull tanker were derived previously by assuming steel labor hours and machinery/outfitting labor hours to be 59% and 41% of the total hours respectively. The steel labor hours for the 40K, 95K and 84KDWT double hull tankers were then obtained from those of the 228KDWT tankers by application of the factors N_D/N_s . The resulting hours were then taken to be 59% of the total, with the remaining 41% applying to machinery/outfitting. Total labor hours were increased by 50,000 for design, as surmised from Figures 5.6 and 5.7, although this figure appears to be quite optimistic.

Table 5.9: ESTIMATED LABOR HOURS JAPAN 1972
(All vessels double hull except 228KDWT)

<u>D</u> <u>W</u> <u>T</u> <u>(M.T.)</u>	<u>LxBxD</u> <u>(meters)</u>	<u>N_s or N_D</u>	<u>N_D/N_s</u>	<u>Steel</u> <u>Hours (59%)</u>	<u>Machy/Outfit</u> <u>Hours (41%)</u>	<u>Total *</u> <u>Labor Hours</u>
228K	313x51x26.18	N _s =78055	-	582,920	405,080	1,038,000
40K	183x31x17.7	N _D =38702	0.50	291,460	202,540	544,000
95K	234x41.5x19.75	N _D =60437	0.77	448,848	311,911	810,759
84K	229x32.24x21.6	N _D =53845	0.69	402,215	279,505	731,720

* Includes 50,000 hours for design

It was now assumed that by 1972 the Japanese had developed half of the improvement in producibility indicated in Table 5.4 for automation (i.e. 16%) and half of the improvement discussed in Section 5.3.3 for statistical accuracy control (i.e. 7.5%). Then the labor hours for construction in Japan in 1994 can be derived from those in Table 5.9 (excluding design hours) by applying similar percentage improvements, i.e. by multiplying by $0.84 \times 0.925 = 0.777$.

Using the 1994 values of steel and machinery/outfitting labor hours derived in this manner, a comparison can be made using both the Japanese and Danish labor hour breakdown percentages of Tables 5.7 and 5.8 to construct Tables 5.10 and 5.11. These Tables represent an estimate of labor hour distribution for the 40K and 95KDWT base alternatives and an 84KDWT tanker, using 1994 estimates of total labor hours. It should be noted that the total hours for the 84KDWT data are based on the Japanese data, but its labor hour distribution is based on the Danish data. The latter distribution has been included for purposes of comparison. It may be noted that the total labor hours for the 84KDWT vessel compare favorably with those for an 80KDWT tanker given in Table 5.3, although it is not know whether the latter vessel was a single or double hull tanker.

Table 5.10: STEEL FABRICATION LABOR HOURS (Japan 1994)

	<u>40KDWT</u>	<u>95KDWT</u>	<u>84KDWT</u>
Parts Cutting & Bending	33,970	48,826	42,972
Sub Assembly	29,440	45,338	39,846
Assembly	101,909	167,402	141,416
Erection	61,145	87,189	88,287
Steel Total	226,464	348,755	312,521

Table 5.11: MACHINERY/OUTFITTING LABOR HOURS (Japan 1994)

	<u>40KDWT</u>	<u>95KDWT</u>	<u>84KDWT</u>
Machine Shop			4,343
Pipe fab. and mach. packages	17,311*	24,235*	21,717*
Pipe installation			45,607*
Misc. steel outfitting			36,920*
Hull & Accommodations	39,344*	55,742*	
Mech. installation			17,374*
Joiners & carpenters			17,374*
Machinery Outfitting	28,327	38,777	
Electrical Outfitting	14,164	21,812	34,748
Tests & Trials incl. Dry Docking	9,442	19,388	
Painting	48,786	82,401	39,092
			Danish coating of cargo and WB tanks subcontracted
Machinery & Outfitting Total	157,374	242,355	217,175

Table 5.12: TOTAL STEEL & MACHINERY OUTFITTING

	<u>40KDWT</u>	<u>95KDWT</u>	<u>84KDWT</u>
Total Steel and Machinery Outfitting	383,838	591,110	529,696

*Affected by uniqueness of hull structural concept and difference from base vessel

According to information recently received, [29], the following labor hours for construction were achieved by Japanese and Korean shipyards in 1992:

	<u>Japan</u>	<u>Korea</u>
280KDWT single hull tanker	380-450,000	700-800,000
280KDWT double hull tanker	550-650,000	850-950,000
150KDWT single hull tanker	About 300,000	About 640,000

This information indicates that the projected Far East labor hours for 40K and 95KDWT double hull tankers given in Table 5.11 are supported by the Korean data.

Reference [31] states that some medium and smaller Japanese shipyards are building double hull Aframax tankers (approx. 95KDWT) for 200,000 hours. These hours and the Japanese labor hours above are so low compared with historical and other data bases that for the purpose of this study, the Korean hours have been taken to be typical of Far East construction.

Figure 5.8 provides the Danish B&W yard's "Learning Curve" for series production of 17 double hull tankers of 84KDWT, [18]. The production index of that figure shows that after production of the 17 vessels, the index dropped from 100 down to nearly 50. Stated another way, a shipyard building such a series design can construct the last vessel in one half the labor hours of a shipyard with a one-off design. This displays a clear case for series production and its effect on producibility which, on face value, is likely to overshadow any other improvements on producibility.

However, the advantage of series production is available to all shipyards. A learning curve is not a fixed line and can be improved (i.e. displaced downwards) by superior work methods or design changes. A shipyard that can improve a learning curve by constant small downward displacements will be more competitive.

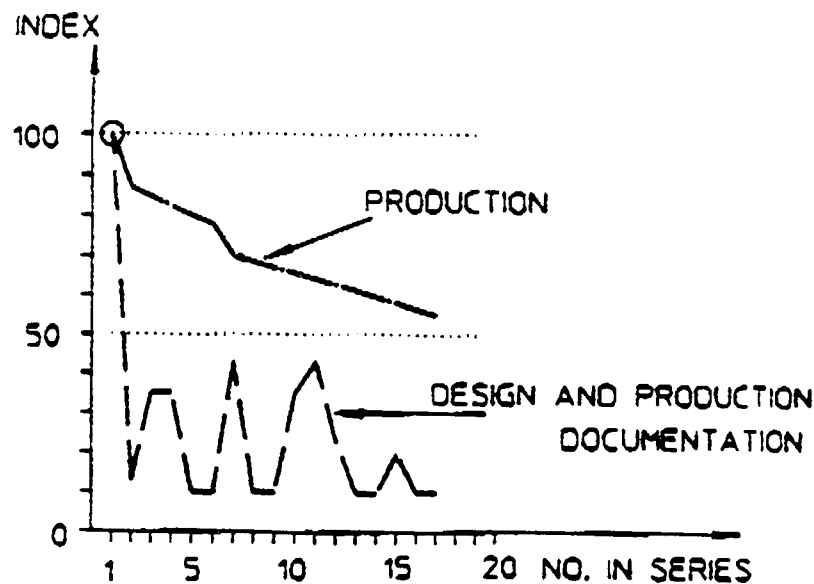

Figure 5.8
Learning Curve for Series Production, [B&W]

5.4 APPLICATION OF ALTERNATIVE STRUCTURAL SYSTEMS

From the list of generic alternative structural system concepts given in Table 4.2, a series of alternative concepts was identified for study and evaluation for both the 40K and 95KDWT vessels.

For the identification of the various structural alternatives, a key code was established as follows. The key number for each 40KDWT alternative starts with 40 and ends in a number such as 10, assigned to identify the structural configuration of the alternative. For example, the 40KDWT base alternative has the number 4010 assigned to it. The other 40K alternatives have numbers 4020, 4030 etc. assigned to them. Similar key numbers, such as 9510, 9520 etc. have been assigned to the 95KDWT alternatives. A full list of the alternatives investigated, together with their key numbers, is provided in Table 5.13. These numbers appear on all calculation sheets. Alternatives 9590 thru 95112, 95130, 95140 and 95150 were not evaluated since experience with other alternatives indicated that the relationship of their producibility to the remainder of the 95KDWT series would not differ greatly from the relationship exhibited by the 40KDWT series.

Table 5.13: ALTERNATIVE STRUCTURAL SYSTEM CONCEPTS

NOTE: All vessels 4010 thru 4090 and 9510 thru 9580 have high strength steel (grade AH32) in the deck and bottom except 4020 and 9520. All unidirectional vessels are mild steel except 40112, which has high strength steel in the deck and bottom. All vessels have conventionally stiffened transverse bulkheads (vertical stiffeners) and center line bulkheads (longitudinal stiffeners), except where noted otherwise.

Key N^o

- 4010 - 40KDWT base vessel with square (bracketed) lower outboard corner of cargo tank.
- 9510 - 95KDWT base vessel with sloped tank side (hopper) at lower outboard corner.
- 4020 - Same as 10, except all mild steel.
- 9520 - Same as 10, except all mild steel.
- 4030 - Same as 10, three times the stiffener sizes in order to minimize weight.
- 9530 - Same as 10, with additional stiffener sizes, as in 4030.
- 4040 - Same as 10, with vertically corrugated transverse bulkhead.
- 9540 - Same as 10, with vertically corrugated transverse bulkhead.
- 4050 - Same as 60, but sloped hopper fitted with formed corners.
- 9550 - Same as 10, but sloped hopper fitted with formed corners.
- 4060 - Same as 10, but with sloped hopper at lower outboard corner.
- 9560 - Same as 10, but with square (bracketed) lower outboard corner of tank.
- 4070 - Same as 10, but with bulb plates in lieu of other stiffeners.
- 9570 - Same as 10, but with bulb plates in lieu of other stiffeners.
- 4080 - Same as 10, but with stiffened elements fashioned from one frame space width of plate with stiffener formed on one side. This in lieu of plate stiffener combinations.
- 9580 - Same as 10, but with stiffened elements fashioned from one frame space width of plate with stiffener formed on one side. This in lieu of plate stiffener combinations.
- 4090 - Same as 10, but with all floor, girder and web stiffeners assumed automatically welded.

- 40100- U4 - Unidirectional alternative with vertically corrugated transverse and center line bulkheads.
- 40110- U5 - Unidirectional alternative with vertically corrugated transverse and center line bulkheads.
- 40111- U5 - Unidirectional alternative with double plate transverse bulkhead and vertically corrugated center line bulkhead.
- 40112- U5 - Unidirectional alternative with high strength steel deck and bottom, vertically corrugated transverse bulkhead and no center line bulkhead.
- 40120- U6 - Dished plate unidirectional alternative, with vertically corrugated transverse and center line bulkheads. Dished plating formed by rolling.
- 95120- U3 - Dished plate unidirectional alternative, with vertically corrugated transverse and center line bulkheads. Dished plating formed by rolling.
- 40121- U6 - Dished plate unidirectional alternative - same as 120, but dished plating formed by pressing and credit given for unique welding. Also, floor, girder and web stiffeners assumed automatically welded.
- 95121- U3 - Dished plate unidirectional alternative - same as 120, but dished plating formed by pressing and credit given for unique welding. Also, floor, girder and web stiffeners assumed automatically welded.
- 40130- Same as 10, but double bottom floors and girders lugged and slotted into bottom shell and inner bottom for easier alignment.
- 40140- Same as 10, but 50% labor hour reduction for series production of standard vessels.
- 40150- Same as 10, with use of design standards for contract/detail designs. Design labor hours reduced from 200,000 to 100,000 and schedule reduced to suit.

A midship section was synthesized for each structural system concept considered. The midship scantlings for all longitudinal items were obtained from the American Bureau of Shipping (ABS) program OMSEC, which incorporates all pertinent sections of ABS Rules. The input consisted of the basic geometry of the midship section, spacing of longitudinals and girders, position of stringers, deck camber and other information pertinent to geometry. With this information, a bending moment estimation provided by the older ABS Rules within the program and an internal table of stiffeners and plating (which can be modified), the program calculates the midship section longitudinal scantlings with required hull girder section modulus and minimum weight as the design parameters. Sample OMSEC outputs for the base alternatives are given in the Appendix.

It should be noted that stiffener sizes were selected from a limited range of flat bars and built-up shapes included in the program, which can result in some stiffeners being oversized. This procedure was followed since it is the practice in some shipyards to restrict stiffener sizes to a limited range to simplify storage, handling and design details. However, intermediate sizes of stiffeners were also added to the program and alternatives 4030 and 9530 included in the list of structural alternatives studied, so that any oversized stiffeners could be replaced by smaller sizes. Alternatives 4030 and 9530 are otherwise similar to the base alternatives 4010 and 9510 respectively.

Since they are not included in the OMSEC program, the scantlings of transverse structure and bulkheads were determined from ABS Rules for the 40KDWT and were adapted from similar ship's drawings for the 95KDWT alternatives.

For the unidirectional alternatives, an assumed spacing of longitudinal girders was used to enable the OMSEC program to calculate the required minimum ABS Rule shell plating thickness. In addition, some approximate calculations were performed to obtain representative scantlings for the longitudinal girders.

For the dished plate unidirectional alternatives, plating thickness was estimated by considering the additional strength due to curvature over an equivalent flat plate structure. It should be noted that the spacing of longitudinal girders for the dished plate vessels is greater than that of the other unidirectional alternatives, as approximately identical shell thickness was maintained and the additional strength due to curvature allowed greater girder spacing. Also, the scantlings of the dished plate double hull were maintained constant around the entire periphery of the midship section. This feature, which can be applied to any of the unidirectional alternatives, enables the number of unique structural blocks to be considerably reduced, but incurs some weight penalty.

5.5 STRUCTURAL BLOCKS

To simplify the producibility investigation, yet keep it meaningful, only one midship cargo tank length of each structural alternative concept, including one transverse bulkhead, was selected for initial comparison and evaluation.

Since the producibility study required seams and butts of plating to be located, it was then necessary to break down the midship tank structure into suitable blocks for erection. Some discussion of block breakdown is provided in Section 4.2, item 15, and the actual breakdown selected is shown in Figures 5.9 and 5.10. It may be noted that the breakdown is similar for both the 40K and 95KDWT alternatives, although the numbering systems are different, as indicated in Section 6.3.

The lengths of the blocks were based on the length of cargo tanks (17.9m. for 40K and 25.06m. for 95KDWT alternatives) and the 3.58m. spacing of transverse floors and webs. Thus, the block lengths are 7.16m. forward and 10.74m. aft for 40K and 10.74m. forward and 14.32m. aft for 95KDWT alternatives. These arrangements provide some repetitive blocks within the parallel mid-body of the vessels. The transverse bulkheads inside the double hull formed separate blocks.

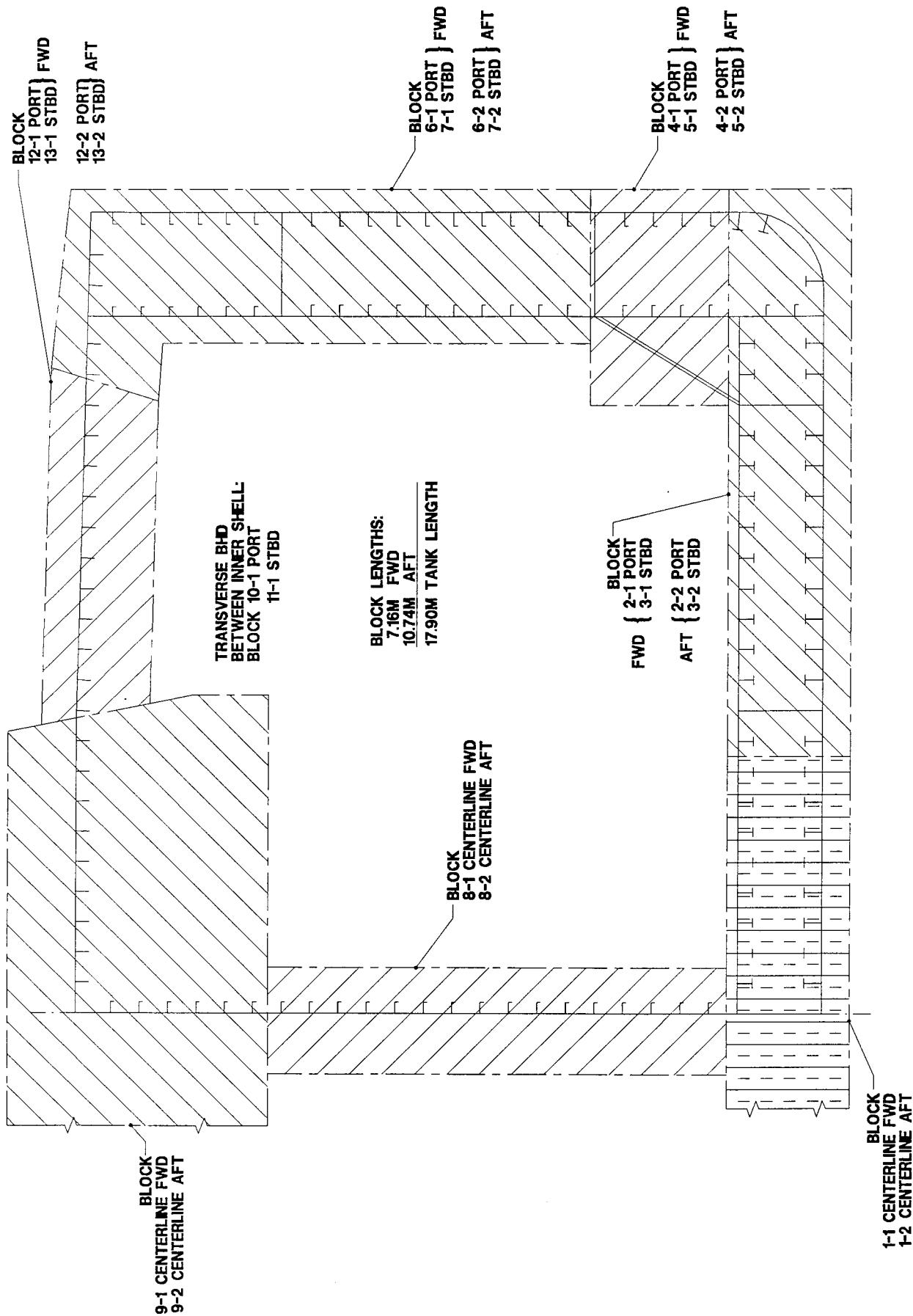

Figure 5.9
BLOCK BREAKDOWN FOR 40KDWT BASELINE

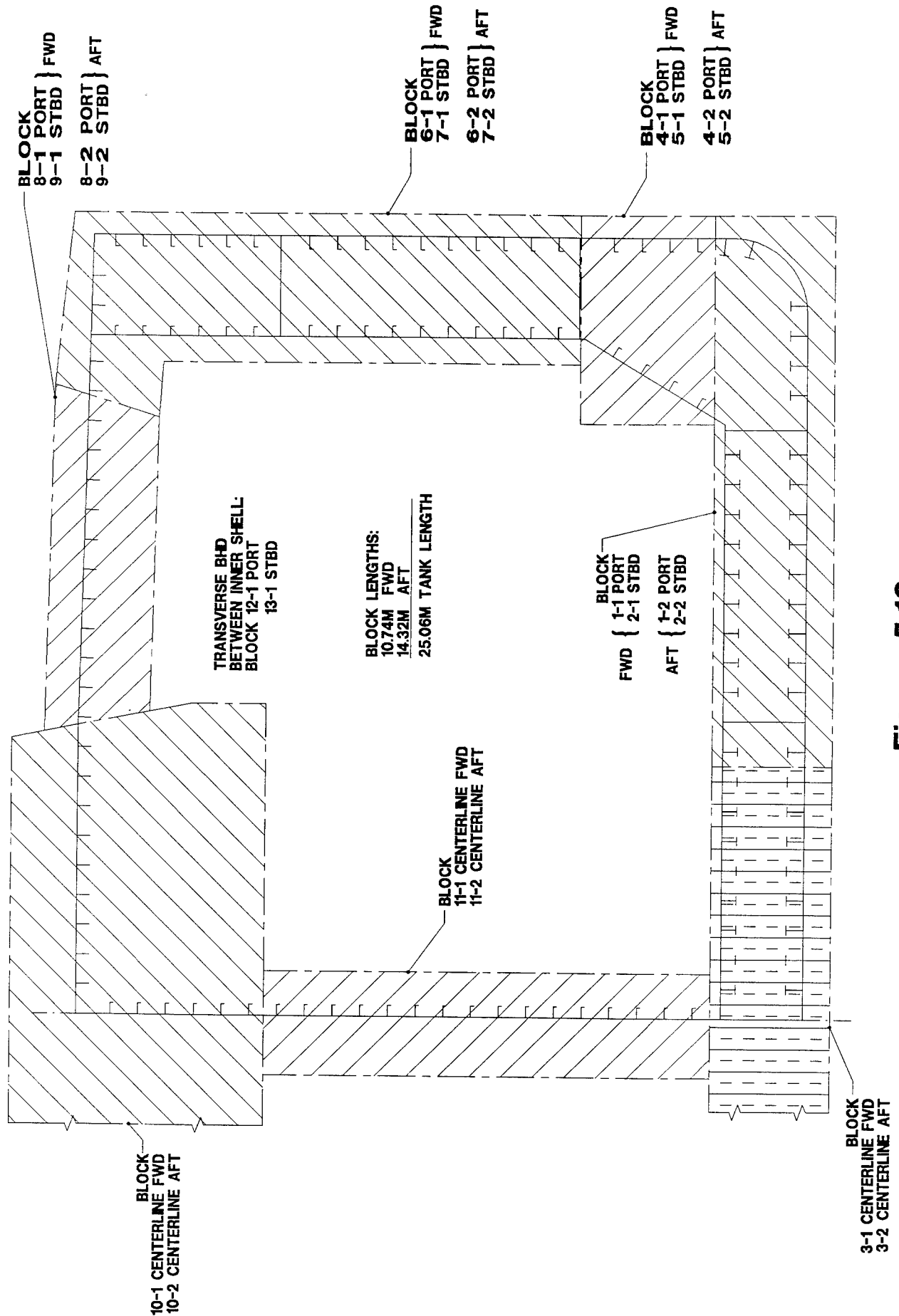

Figure 5.10
BLOCK BREAKDOWN FOR 95KDWT BASELINE

6.0 TASK V - ESTIMATES OF PHYSICAL PRODUCTION CHARACTERISTICS FOR ALTERNATIVE STRUCTURAL SYSTEM CONCEPTS

6.1 OBJECTIVE

The objective of this task is the development of production characteristics such as weight, number of pieces and other quantifying estimates for each of the alternative structural system concepts. They are utilized in the next Section to study the concepts in terms of producibility.

6.2 APPROACH

In considering the producibility of the various alternative structural system concepts, it is necessary to consider many characteristics aspects of the structure, including the following, [31]:

- amount of welding
- type and number of frames, and stiffeners
- number of unique pieces
- total number of pieces
- weight
- surface area for coatings
- number, type and position of welded joints
- self-alignment and support
- need for jigs and fixtures
- work position
- number of physical turns/moves before completion
- aids in dimensional control
- space access and staging
- standardization
- number of compartments to be entered to complete work

The quantification of these characteristics for producibility considerations should generally be in terms of physical quantities, i.e. weight, number of pieces, number and length of welded joints, etc., or the labor hours and schedule time required for their construction or application. The remainder of this sub-section describes how the physical quantifications were made. The labor hour and schedule quantifications are described in Section 7.0.

As indicated in Section 5.5, the structure of one complete midship tank section for each alternative, port to starboard, including one transverse bulkhead, was studied for the purposes of considering producibility. Following the breakdown into structural blocks described in Section 5.5, the quantification of the characteristics noted above then required each one tank length alternative to be broken down into all its component plates, longitudinals, stiffeners, brackets and chocks. A spreadsheet computer program was utilized for this purpose to form the basis for quantifying the various physical steel construction properties of the alternatives. The spreadsheet format is shown in Figure 6.1. An entire sample data set is presented in the Appendix, on pages A29 through A60, for both the 40 and 95KDWT baseline alternatives. These data include the number of unique pieces, total number of pieces, dimensions and

thickness of plates, type, length, thickness and cross section area of longitudinals and stiffeners, surface areas of plates, longitudinals and stiffeners, weights, weld type (automatic, manual, fillet, butt), weld position, weld length and weld volume. These properties of the various alternatives were derived for each structural block and then totalled for all blocks. Metric units were used throughout. Certain characteristics were defined and handled as follows:

- Number of Unique Pieces - Any structural member such as a plate or longitudinal with unique dimensions, including thickness, was counted as a unique element within each one tank length alternative.
- Total Number of Pieces - The number of separate structural pieces such as plates or longitudinals in each alternative.
- Number and Dimensions of Plates and Longitudinals etc. - The number, dimensions and thickness of plates were listed, together with the length, thickness and cross section area of all sectional material such as flat bars, angles, tees and bulb flats.
- Surface Area of Plates and Sections - The surface area (one side only) of all plates and sections in each alternative. No account was taken of lightening holes or other cutouts in plating. This data was used in Section 7.0 to estimate the labor hours required for coatings.
- Steel Weight - The total weight of all structural members in each alternative. No account was taken of lightening holes or other cutouts in plating.
- Welded Joints and Weld Volume - As previously indicated, weld volume was adopted as a measure of steel labor hours, although it was later replaced by weld length and steel thickness.

Manual and automatic welding processes were considered for both fillet and butt welds. Longitudinal erection seams were assumed to be automatically welded, while transverse erection butts were assumed to be manually welded. Elsewhere, manual or automatic welding was assigned in accordance with current shipbuilding practice. Plate thicknesses were subdivided for welding purposes according to whether they were less than/equal to 19 mm or greater than 19mm, since the latter require significantly more edge preparation than lesser thicknesses, such as 10 to 16 mm., [7]. Weld length for plates was split up into flat and curved plate categories. Weld volume was estimated as a function of steel thickness for butt welds and leg length for fillet welds. Leg length was selected according to steel thickness.

Weld positions considered were flat (i.e. downhand), horizontal (on sloping or vertical structure), vertical and overhead. Since welding speeds vary with weld position, the calculated volumes were increased by suitable factors to account for the relative speeds in estimates of labor hours. Factors of 1 for flat, 2 for horizontal, and 3 for vertical were applied, [33], while an estimated factor of 4 was applied to overhead. For a downhand/overhead weld, an estimated factor of 2 was applied. A further factor of 2 was applied to manual welds to take some account of the difference in labor hours for manual versus automatic welding, [34]. The welding positions for each alternative was derived from a construction scenario for each unit based on laying plate, attaching stiffeners, placing cross structure, including floors, and turning to maximize downhand welding.

Weld volumes were therefore determined from the following formulae:

Fillet Weld

Volume V_f	= $\frac{1}{2}l^2 \times f_1 \times f_2 \times f_3 \times L$ ($\text{cm}^2 \cdot \text{M}$)
where l	= leg length (cm)
$l^2/2$	= total fillet weld area (cm^2)
f_1	= 1 for one fillet, 2 for two fillets
f_2	= 1 for automatic, 2 for manual
f_3	= 1 for flat = 2 for horizontal = 3 for vertical = 4 for overhead
L	= length of weld (M)

Butt Weld

Half Volume V_b	= $\frac{1}{2}t^2 \times b_1 \times b_2 \times b_3 \times L$ ($\text{cm}^2 \cdot \text{M}$)
where t	= thickness of material joined (cm)
b_1	= 1 for single Vee, $\frac{1}{2}$ for double Vee
b_2	= 1 for automatic, 2 for manual
b_3	= 1 for downhand = 2 for horizontal = 3 for vertical = 4 for overhead
L	= Length of weld (M)

NOTE: Half volume of butt welds calculated since volume computed on spreadsheet by summing up the half volumes on each of 2 adjoining plates or sections.

The welding of the hull structure of the unidirectional alternatives was assumed to be conventional, i.e. longitudinal plate seams butt welded clear of longitudinal girders, which are fillet welded to the shell plating etc. However, for the dished plate unidirectional alternatives, it is understood that a highly automated welding process is being developed for the welding of the longitudinal girders to the shell plating etc., [10] [35]. As shown in Figure 3.5, the junction of a longitudinal girder with adjacent panels of dished plating forms a 3 way joint. Since it is believed that this joint is welded completely by the above process, it would appear that the welding must be performed with the joint set vertically. Robotic welding of the girder stiffeners has also been proposed.

Since details of the welding of the 3 way joint are not known, the weld cross-section was assumed to be rectangular (sides defined by the plating thicknesses) for the purpose of calculating weld volume.

For estimating steel labor hours for the dished plate unidirectional alternatives 40120 and 95120, welding of the 3 way joints was assumed to be equivalent to automatic vertical butt welding, with manual welding of the girder stiffeners. However, in anticipation that the special welding technique referred to may be transportable in some form to an existing U.S. yard without existing facilities enhancements, dished plate unidirectional alternatives 40121 and 95121 were assumed to be welded with this technique, to represent the application of such technology.

The labor hours for the vertical 3 way joints were then assumed identical to those for the fastest conventional welding, i.e. automatic downhand welding. Automatic welding of the girder stiffeners was also assumed, so as to mimic the proposed robotic welding. It should be noted that the 3-way joints could also appear in the smooth plate unidirectional alternatives, and their application in 40121 and 95121 should be indicative of the benefit in both types of alternatives.

6.3 **RESULTS**

Although the data listed was calculated for each alternative, only summaries by block for the remainder of the alternatives of each ship size are presented in the Appendix on pages A61 through A72, since full data sets for each alternative would require too voluminous a document. Summaries of the number of pieces, areas, weights, weld lengths and weld volumes for the 40K and 95K alternatives are also presented in the Appendix on pages A73 through A84. Graphs of areas, weights, weld lengths and weld volumes are presented in the Appendix on page A117 through A122. Graphs of lengths for flame cutting, edge preparation and different types of welds are presented on pages A126 and A127.

The original numbering system adopted for the structural blocks is utilized for the 95KDWT alternatives, but the block numbers were later changed to reflect numerically the erection sequence anticipated for both sizes of vessel. The revised numbers were then utilized for the 40KDWT alternatives. It may be noted that the block breakdown is the same for both sizes of vessels. A discussion of block breakdown is provided in Section 4.2, item 15 and Figures 5.9 and 5.10 show the block breakdown and block numbers for the 40K and 95KDWT alternatives respectively.

Although it was originally intended to use the length of welded joints as a measure of steel labor hours, weld volume was later considered to be a more realistic measure. However, it was later decided to use References [36] and [37] for the estimation of steel labor hours, which require weld length and steel thickness in lieu of weld volume.

7.0 TASK VI - LABOR HOURS AND SCHEDULES

7.1 OBJECTIVE

The objective of this task is to estimate the labor hours and schedules required to produce the alternative structural system concepts for each of the 40K and 95KDWT double hull tanker designs. The principal characteristics of interest are the labor hours and schedules to produce the vessels.

7.2 APPROACH

As indicated in Section 6.3, it was decided to estimate steel labor hours by adopting and modifying a method proposed in References [36] and [37]. Initially, the intent was to utilize the relative producibility procedure of Reference [36], based on the Analytic Hierarchy Process (AHP). However, further study indicated that with some modifications, the labor hour approach of this reference would be more suitable for the study of the alternatives. Full details of the method to determine labor hours and schedules are given in Sections 7.3 thru 7.5.

In order to establish a baseline for studying of the alternatives, it was first necessary to establish more accurate estimates of the labor hours and schedules for the construction of the baseline vessels in a typical U.S. shipyard.

U.S. shipbuilding's introduction of automation and accuracy control has been advancing but is acknowledged as being behind that abroad. As a result, both were taken as one-half of the 32% presented in Table 54 for a Far Eastern automated yard's advantage over a traditional yard in 1985. One half of the 15% improvement in overall production by implementation of strict dimensional controls and statistical accuracy, as discussed in Section 5.3.3 for Far Eastern yards. Then the U.S. yards can be expected to achieve the labor hours and schedules of construction for the base alternative vessels shown in Table 7.1 and 7.2 respectively.

The schedules in Table 7.2, also shown in Figure 7.1, are from contract signing to delivery, and have been developed to incorporate about 12 months from the start of fabrication to launch, since this was required in 1983 for the last series of tankers to be constructed in the U.S. - see Figure 5.4. These schedules have some potential slack at the beginning and end (particularly from trials to delivery), allowing for meeting contractual dates. It may be noted that the design labor hours were based on the anticipated performance of U.S. shipyards. It may be further noted that according to the data provided by Reference [19], there is almost no difference between the 40K and 95KDWT Far East baseline building schedules. Therefore no difference is shown in Table 7.2.

Table 7.1

**TOTAL ESTIMATED LABOR HOURS FOR CONSTRUCTION OF BASELINE SHIPS
IN U.S. IN 1994**

	<u>40KDWT</u>	<u>95KDWT</u>
Far East Base Labor Hours for construction (from Table 5.11)	383,838	591,110
{Increase for U.S. due to lesser automation and accuracy control.	110,162	169,649
Design Labor	<u>200,000</u>	<u>225,000</u>
U.S. Total Labor Hours	694,000	985,759

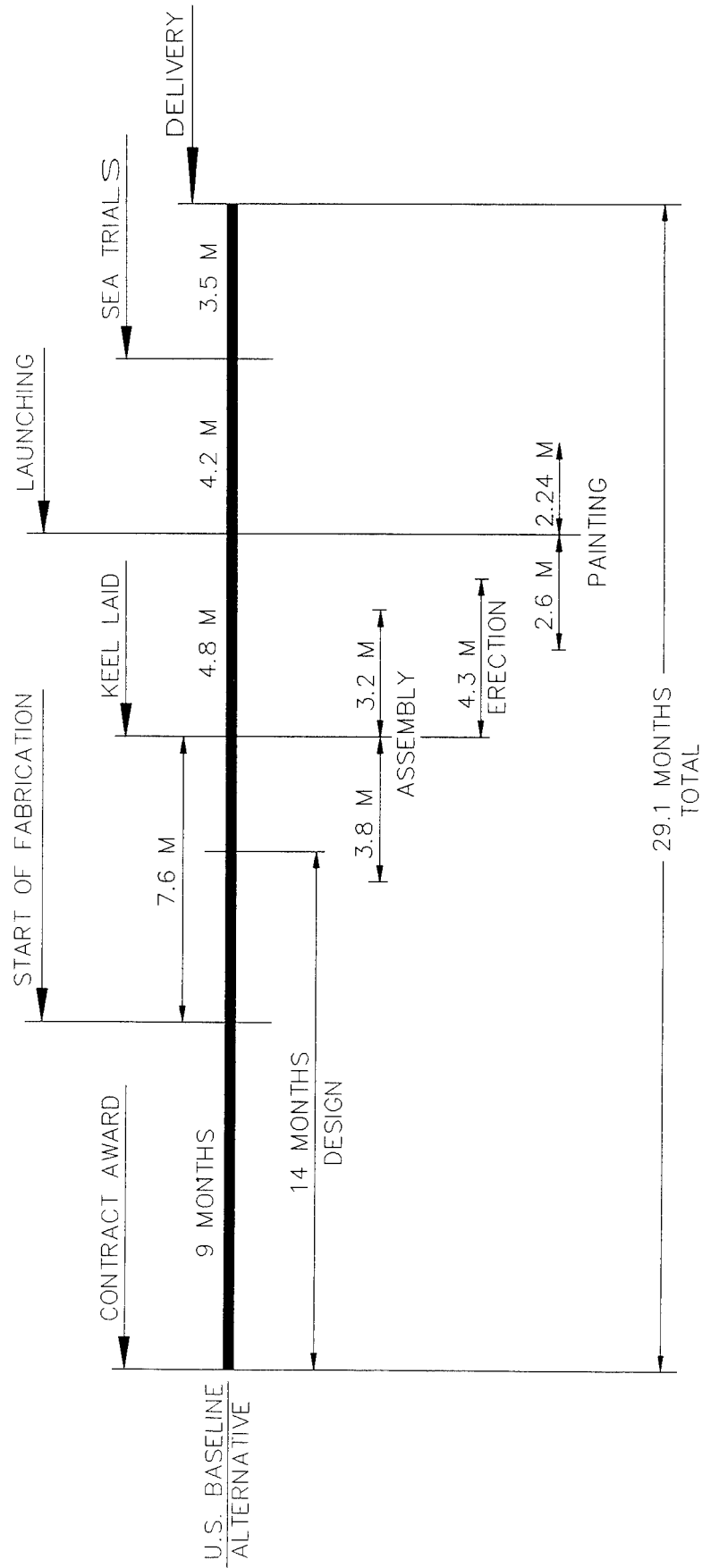

FIG. 7.1 - 1994 U.S. BASE TIME LINE SCHEDULE

Table 7.2

ESTIMATED SCHEDULE FOR CONSTRUCTION OF
BASELINE SHIPS IN U.S. IN 1994.

	<u>40KDWT</u>	<u>95KDWT</u>
Far East Baseline Schedule, including design (from Figure 5.5)	20.5 months	20.5 months
{Increase for U.S. due to lesser automation and accuracy control, applied from fabrication to sea trials.	2.6 "	2.6 "
Additional Design Period	<u>6.0 "</u>	<u>6.0 "</u>
U.S. Schedule for Construction	29.1 months	29.1 months

7.3 LABOR HOURS FOR STEELWORK

The following notes provide the assumptions, approaches and details of the method used to estimate the steel labor hours required for the construction of the various one tank length alternatives.

a) In order to estimate the steel labor hours required to construct one midship cargo tank section for the various structural alternatives, the steel labor hours required to construct the complete 40K and 95KDWT base vessels were first obtained from the total labor hours (excluding design labor) given in Table 7.1. For this purpose, the average percentage breakdown of steel versus outfitting hours given in Table 5.6 for the construction of vessels in Japan was used, i.e. 59% for steel construction and 41% for outfitting.

Then total steel labor hours to construct 40K and 95KDWT base vessels are 291,460 and 448,848 respectively.

An estimate of the steel labor hours to construct one cargo tank section for the base vessels was then obtained from a consideration of the relative lengths of the separate parts of the vessels (i.e. 7 cargo tanks + bow + stern + superstructure), the structural contents of each part and the relative complexity (e.g. curved shell plating) of the structure. Approximately 10% of the total steel hours was required, but this was later refined to 9.53% and 10.42% for the 40K and 95KDWT vessels respectively in the following manner:

The 40K and 95KDWT vessels each have 7 cargo tank sections, with constant lengths of 17.9m and 25.06m respectively. Steel labor hours for No. 1 & 2 cargo tank sections were estimated to be 85% and 95% respectively of those for the midship cargo tank section. Steel labor hours for the remaining five tank sections were all assumed to be the same as for the midship tank section. Steel labor hours for the remaining bow and stern portions of the vessels were assumed initially to vary with those for the midship tank in proportion to length, and were then corrected for volume and structural contents by applying an estimated correction factor of 0.7. Estimated structural complexity factors of 1.5 and 1.3 for bow and stern respectively were then applied to allow for more difficult construction. Steel labor hours for the deckhouse and stack were similarly assumed to vary with length, followed by the application of an estimated

single correction factor of 0.5. Lengths of the bow, stern and deckhouse for the 40K and 95KDWT vessels were taken to be 10.5m/10.66m for the bow, 47.2m/47.92m for the stern and 24/30.7m for the deckhouse.

Based on these assumptions, it can be shown that the total steel labor hours to construct the 40K and 95KDWT base vessels are equivalent to the hours required to construct 10.49 or 9.60 midship tanks respectively. Then the steel labor hours to construct one midship tank section for the 40K and 95K base vessels can be obtained by multiplying the total steel hours by $1/10.49$ (i.e. 9.53%) or $1/9.60$ (i.e. 10.42%) respectively. Thus the required labor hours are 27,785 or 46,755.

b) In order to study the various structural one tank length alternatives, a method of estimating the steel labor hours for each, as compared with the two base designs, was now required. As indicated in Section 7.2, it was therefore decided to utilize the method provided in References [36] and [37] to obtain the man hours to construct the various one tank length alternatives.

This method identifies all of the work processes used to manufacture a steel product (e.g. flame cutting, welding, etc.) and assigns appropriate work units such as linear feet or square feet to each. The individual work units are then multiplied by an appropriate process factor (labor hours/work unit) to obtain the labor hours for each process.

Each work process is performed in or at a particular work site or construction stage (e.g. fabrication shop or erection site) and for each of these, difficulty factors have been assigned to account for the progressive increase in the difficulty of manufacturing a product under varying conditions. The stages utilized and their associated difficulty factors are shown in Table 7.3.

Table 7.3: Construction Stages and Difficulty Factors, [36]

	<u>Stage</u>	<u>Location</u>	<u>Difficulty Factor</u>
1.	Fabrication	In Shop	1.0
2.	Pre-Paint Outfitting	On Platten - Hot work	1.5
3.	Painting	Paint Ship/Stage	2.0
4.	Post-Paint Outfitting	On Platten - Cold Work	3.0
5.	Erection	Erection Site	4.5
6.	Outfitting	Erection Site	7.0
7.	Waterborne	Pierside after Launch	10.0
8.	Tests and Trials	Pierside & Underway	15.0

To account for the impact of construction stages on steel labor hours, the typical stage for each process is identified as standard. If a process is performed in a later stage, the labor hours obtained as above are increased in the ratio of actual to standard difficulty factor. Values of this ratio less than 1.0 are not permitted by the program.

When the labor hours for each work process have been obtained, they are summed to provide the total steel trade labor hours. This total is then increased by an appropriate percentage to account for steel trade support labor hours.

The calculations are performed on spreadsheets, and a typical example from Reference [36] is shown in Table 7.4. The spreadsheet input files provided with the above references are contained on computer disks for Lotus.

Further to the process factors, many of these vary with material thickness and appropriate factors are automatically selected from "look-up" tables within the program spreadsheet when the thickness is inputted. The steel thickness used for each alternative in this evaluation procedure was the average thickness, derived from the weight of the tank section and the surface area of the steel components. The programmed process factors are given in Table 7.5 for a range of thickness from 0.25 inch to 2.00 inches. The factors for shaping steel are standard except for bending, rolling and pressing. These have basic values of 0.40, 1.00 and 0.02 respectively, which are multiplied by appropriate thickness factors to obtain the required process factors. Other factors not listed in Table 7.5 have the standard values shown in Table 7.4.

c) For the application of this procedure to the structural alternatives, surface preparation, coating and testing were removed from the list of work processes, since they were considered to be part of machinery/outfitting for the purposes of this report.

However, "rework" was included as an additional factor. Furthermore, the process factors needed adjustment to correlate with commercial construction, since the factors in Reference [35] were based on Philadelphia Naval Shipyard repair information. This may be illustrated by the application of the described procedure to the 40K and 95KDWT baseline vessels, using the programmed process factors with no modification and with no rework included. This resulted in steel labor hours exceeding those estimated in paragraph (a) by 62.70% and 47.28% for the 40K and 95KDWT vessels respectively. As indicated in Table 7.1, the estimates of labor hours required to construct the 40K and 95KDWT base vessels assume that U.S. yards have instituted one half of the effort expended by the Japanese on accuracy control. However, some rework will still be required, as it is in Japan, and for the purposes of evaluation of the structural alternatives, this has been assumed to require 10% of the labor hours expended on flame cutting, edge preparation, fit up/assembly and welding. Finally, the process factor of 0.10 hours/sq. ft. for obtaining material/receipt etc. was considered to be too high and was reduced to 0.01 hours/sq.ft.

Table 7.4

COST ESTIMATING FORM FOR STRUCTURAL WORK

PROJECT: FILE :	"TITLE" XYZ123.WK1	MATERIAL: THICKNESS	MS-ST 0.57 INCHES					
WORK PROCESS	WORK UNITS	PROCESS FACTOR (MNHRS/ WORK UNIT)	UNIT AMOUNT	ACTUAL STAGE	STANDARD STAGE	ACTUAL FACTOR	STANDARD FACTOR	MNHRS REQ'D
1 OBTAIN MATERIAL RECEIPT & PREP	SQ FT	0.100	0	1	1	1.0	1.0	0
2 FLAME CUTTING AUTOMATIC	LN FT	0.050	0	1	1	1.0	1.0	0
MANUAL	LN FT	0.090	0	2	2	1.5	1.5	0
3 EDGE PREP-GRINDING FLAT	LN FT	0.040	0	1	2	1.0	1.5	0
VERTICAL	LN FT	0.060	0	2	2	1.5	1.5	0
OVERHEAD	LN FT	0.080	0	2	2	1.5	1.5	0
4 SHAPING BREAK	BEND	0.480	0	1	1	1.0	1.0	0
ROLLING	PIECE	1.200	0	1	1	1.0	1.0	0
LINE HEATING	PIECE	10.000	0	1	1	1.0	1.0	0
FURNACE	PIECE	15.000	0	1	1	1.0	1.0	0
PRESS	PIECE	0.024	0	1	1	1.0	1.0	0
MACHINING	CU IN	0.020	0	1	1	1.0	1.0	0
5 FIT UP & ASSEMBLY	JOINT	0.560	0	2	2	1.5	1.5	0
6 WELDING, AUTO/MACHINE FILLET	LN FT	0.065	0	2	2	1.5	1.5	0
BUTT	LN FT	0.48	0	2	2	1.5	1.5	0
7 WELDING, MANUAL FILLET DOWNHAND	LN FT	0.340	0	2	2	1.5	1.5	0
VERTICAL	LN FT	0.510	0	2	2	1.5	1.5	0
OVERHEAD	LN FT	0.680	0	2	2	1.5	1.5	0
BUTT DOWNHAND	LN FT	1.300	0	2	2	1.5	1.5	0
VERTICAL	LN FT	1.950	0	2	2	1.5	1.5	0
OVERHEAD	LN FT	2.600	0	2	2	1.5	1.5	0
8 MARKING	PIECE	0.100	0	1	1	1.0	1.0	0
9 HANDLING STORAGE	PIECE	0.100	0	2	2	1.5	1.5	0
TRANSPORTING	ASSY	5.000	0	3	3	2.0	2.0	0
LIFTING	ASSY	5.000	0	4	4	3.0	3.0	0
10 SURFACE PREP BLASTING	SQ FT	0.100	0	3	3	2.0	2.0	0
GRINDING	FOOT	0.200	0	3	3	2.0	2.0	0
11 COATING	SQ FT	0.100	0	3	3	2.0	2.0	0
12 TESTING DYE PENETRANT	FOOT	0.250	0	2	2	1.5	1.5	0
AUDIOGAGE	FOOT	0.500	0	2	2	1.5	1.5	0
X RAY	FOOT	0.500	0	2	2	1.5	1.5	0
TOTAL TRADE MANHOURS								0
TRADE SUPPORT MANHOURS (35% OF TRADE MANHOURS)								0
TOTAL PRODUCTION MANHOURS								0
LABOR COST (MANHOURS X MNHR COST)				\$20.00				\$0
MATERIAL COST (FROM MATERIAL SCHEDULE)								\$0
TOTAL COST								\$0

NSRP PANEL SP-4
 FILE: STRCTMS

THICKNESS (INCHES)	1 FLAME CUTTING AUTO	2 FLAME CUTTING MANUAL	3 EDGE PREP GRINDING FLAT	4 EDGE PREP GRINDING VERTICAL	5 EDGE PREP GRINDING OVERHEAD	6 ASSEMBLY	7 MACHINE FILLET
0.250	0.05	0.09	0.02	0.04	0.06	0.56	0.04
0.375	0.05	0.09	0.03	0.05	0.07	0.56	0.05
0.500	0.05	0.09	0.04	0.06	0.08	0.56	0.07
0.750	0.07	0.12	0.06	0.12	0.17	0.56	0.08
1.000	0.07	0.16	0.08	0.17	0.26	0.56	0.09
1.250	0.08	0.17	0.12	0.21	0.30	0.56	0.11
1.500	0.1	0.18	0.17	0.26	0.34	0.56	0.13
2.000	0.12	0.23	0.17	0.26	0.34	0.56	0.16

THICKNESS (INCHES)	1 DOWN	2 Fillet VERT	3 OVHD	4 DOWN	5 VERT	6 OVHD	7 THICKNESS FACTOR
0.250	0.12	0.24	0.36	0.62	1.24	1.86	1.00
0.375	0.23	0.38	0.54	1.00	1.67	2.33	1.20
0.500	0.34	0.51	0.68	1.30	1.95	2.6	1.20
0.750	0.6	1.2	1.7	1.80	3.6	5.1	1.20
1.000	1	2.13	3.25	2.40	5.1	7.8	1.20
1.250	1.2	2.1	3.00	3.20	5.6	8	1.20
1.500	1.44	2.2	2.88	3.80	5.81	7.6	1.20
2.000	1.73	2.64	3.46	5.10	7.8	10.2	1.20

Table 7.5
 PROCESS FACTORS

d) When the remaining programmed process factors were applied to the 40K and 95KDWT base designs for one tank length, the resultant steel labor hours were found to be higher than the estimates given in paragraph (g). The excess amounted to 40.23% for 40K and 23.58% for 95KDWT designs, with an average of 31.90%.

It would appear justifiable therefore, to reduce some of the process factors to enable the labor hour estimates of paragraph (a) for the two base designs to be correlated. It would appear, in particular, that process factors for work processes 2,3,5,6 and 7 in Table 7.4 should be reduced. Since it was desirable to use identical process factors for both ship sizes, varying only with material thickness, it was decided to reduce programmed factors by 20.75%. The standard 35% used on the spreadsheet (Table 7.4) for trade support hours was also reduced by the same percentage, i.e. to 28%. This procedure provided steel labor hours for the midship cargo tanks of the 40K and 95KDWT base designs that differed from those given in paragraph (a) of this Section by about $\pm 6\%$, which was considered satisfactory. The amended labor hours for the midship tanks then became 29,578 and 43,872 respectively. The steel labor hours for all alternatives were therefore computed on this basis. The corresponding modified spreadsheets are shown in Tables 7.6 and 7.7.

e) Further to the application of the estimating procedure of References [36] and [37], the following assumptions were made to suit the format of the procedure shown in Tables 7.6 and 7.7:

- Manual flame cutting assumed employed on 5% of total plate edge length.
- Edge preparation and grinding employed only in way of manual flame cutting.
- On data sets and block summaries in the Appendix, welding has been delineated as automatic or manual, welded joints as butts or fillets and welding positions as flat (i.e. downhand), horizontal, vertical or overhead. To suit the estimating spreadsheet, welding lengths were then regrouped into automatic butt or fillet welds - or manual butt or fillet welds in downhand, vertical or overhead positions.
- Although metric units have been used throughout this report, British units were used in the estimating procedure since these units were used in References [36] and [37].

f) The completed spreadsheets for the estimation of the steel labor hours for the one tank length structural alternatives are given in the Appendix on pages A87 through A115 for both the 40 and 95KDWT designs. The results are also shown graphically in Figures 7.2 and 7.3 for the 40K and 95KDWT designs respectively, and in the Appendix on page A124. Figures 7.2 and 7.3 include a breakdown of the labor hours required separately for obtaining material/flame cutting etc. (work processes N^o 1 thru 4), fit up and assembly (work process N^o 5), automatic welding (work process N^o 6), manual welding (work process N^o 7), marking and handling etc. (work processes N^o8 and 9) and rework (work process N^o 10).

g) Further to the calibration of the steel labor hours to suit the estimating procedure described in paragraph (d), it was considered desirable to validate this further by applying the same procedure to the estimated steel labor hours for the construction of the 40K and 95KDWT vessels in the Far East in 1994.

Table 7.6

NSRP PANEL SP-4
FILE: STRCTMS Revised

LABOR HOUR ESTIMATING FORM FOR STRUCTURAL WORK
40KDWT BASE ALTERNATIVE
Entire Tank Section MATERIAL: MS-ST5
4010 THICKNESS 0.57 INCHES

WORK PROCESS	WORK UNITS	PROCESS FACTOR (MNHRS/WORK UNIT)	UNIT AMOUNT	ACTUAL STAGE	STANDARD STAGE	ACTUAL FACTOR	STANDARD FACTOR	MNHRS REQ'D
1 OBTAIN MATERIAL RECEIPT & PREP	SQ FT	0.010	79149	1	1	1.0	1.0	791
2 FLAME CUTTING								
AUTOMATIC	LN FT	0.040	47582	1	1	1.0	1.0	1885
MANUAL	LN FT	0.071	2504	2	2	1.5	1.5	179
3 EDGE PREP - GRINDING								
FLAT	LN FT	0.032	1990	1	2	1.0	1.5	63
VERTICAL	LN FT	0.048	407	2	2	1.5	1.5	19
OVERHEAD	LN FT	0.063	108	2	2	1.5	1.5	7
4 SHAPING								
BREAK	BEND	0.380	0	1	1	1.0	1.0	0
ROLLING	PIECE	0.951	4	1	1	1.0	1.0	4
LINE HEATING	PIECE	10.000	0	1	1	1.0	1.0	0
FURNACE	PIECE	15.000	0	1	1	1.0	1.0	0
PRESS	PIECE	0.019	0	1	1	1.0	1.0	0
MACHINING	CU IN	0.020	0	1	1	1.0	1.0	0
5 FIT UP & ASSEMBLY	JOINT	0.444	6568	2	2	1.5	1.5	2915
6 WELDING, AUTO/MACHINE								
FILLET	LN FT	0.052	49968	2	2	1.5	1.5	2574
BUTT	LN FT	0.3804	3530	2	2	1.5	1.5	1343
7 WELDING, MANUAL								
FILLET								
DOWNHAND	LN FT	0.269	22352	2	2	1.5	1.5	6023
VERTICAL	LN FT	0.404	4571	2	2	1.5	1.5	1847
OVERHEAD	LN FT	0.539	1213	2	2	1.5	1.5	653
BUTT								
DOWNHAND	LN FT	1.030	1579	2	2	1.5	1.5	1627
VERTICAL	LN FT	1.545	323	2	2	1.5	1.5	499
OVERHEAD	LN FT	2.061	86	2	2	1.5	1.5	177
8 MARKING	PIECE	0.100	1642	1	1	1.0	1.0	164
9 HANDLING								
STORAGE	PIECE	0.100	1642	2	2	1.5	1.5	164
TRANSPORTING	ASSY	5.000	24	3	3	2.0	2.0	120
LIFTING	ASSY	5.000	24	4	4	3.0	3.0	120
10 REWORK	JOINT	1.000	660	5	2	4.5	1.5	1981
TOTAL TRADE LABORHOURS								23156
TRADE SUPPORT LABORHOURS (28% OF TRADE LABORHOURS)								6423
TOTAL PRODUCTION LABORHOURS								29578

Table 7.7

NSRP PANEL SP-4
 FILE: STRCTMS Revised

LABOR HOUR ESTIMATING FORM FOR STRUCTURAL WORK
 95KDWT BASE ALTERNATIVE

PROJECT: Entire Tank Section MATERIAL: MS-ST5
 FILE: 9510 THICKNESS 0.6 INCHES

WORK PROCESS	WORK UNITS	PROCESS FACTOR (MNHRS/WORK UNIT)	UNIT AMOUNT	ACTUAL STAGE	STANDARD STAGE	ACTUAL FACTOR	STANDARD FACTOR	MNHR5 REQ'D
1 OBTAIN MATERIAL RECEIPT & PREP	SQ FT	0.010	132358	1	1	1.0	1.0	1324
2 FLAME CUTTING								
AUTOMATIC	LN FT	0.040	75044	1	1	1.0	1.0	2974
MANUAL	LN FT	0.071	3950	2	2	1.5	1.5	282
3 EDGE PREP-GRINDING								
FLAT	LN FT	0.032	3157	1	2	1.0	1.5	100
VERTICAL	LN FT	0.048	674	2	2	1.5	1.5	32
OVERHEAD	LN FT	0.063	119	2	2	1.5	1.5	8
4 SHAPING								
BREAK	BEND	0.380	0	1	1	1.0	1.0	0
ROLLING	PIECE	0.951	4	1	1	1.0	1.0	4
LINE HEATING	PIECE	10.000	0	1	1	1.0	1.0	0
FURNACE	PIECE	15.000	0	1	1	1.0	1.0	0
PRESS	PIECE	0.019	0	1	1	1.0	1.0	0
MACHINING	CU IN	0.020	0	1	1	1.0	1.0	0
5 FIT UP & ASSEMBLY	JOINT	0.444	9828	2	2	1.5	1.5	4362
6 WELDING, AUTO/MACHINE								
FILLET	LN FT	0.052	82561	2	2	1.5	1.5	4253
BUTT	LN FT	0.3804	6294	2	2	1.5	1.5	2394
7 WELDING, MANUAL								
FILLET								
DOWNHAND	LN FT	0.269	30775	2	2	1.5	1.5	8292
VERTICAL	LN FT	0.404	6568	2	2	1.5	1.5	2654
OVERHEAD	LN FT	0.539	1164	2	2	1.5	1.5	627
BUTT								
DOWNHAND	LN FT	1.030	2346	2	2	1.5	1.5	2417
VERTICAL	LN FT	1.545	501	2	2	1.5	1.5	774
OVERHEAD	LN FT	2.061	89	2	2	1.5	1.5	183
8 MARKING	PIECE	0.100	2457	1	1	1.0	1.0	246
9 HANDLING								
STORAGE	PIECE	0.100	2457	2	2	1.5	1.5	246
TRANSPORTING	ASSY	5.000	24	3	3	2.0	2.0	120
LIFTING	ASSY	5.000	24	4	4	3.0	3.0	120
10 REWORK	JOINT	1.000	978	5	2	4.5	1.5	2935
TOTAL TRADE LABORHOURS								34346
TRADE SUPPORT LABORHOURS (28% OF TRADE LABORHOURS)								9527
TOTAL PRODUCTION LABORHOURS								43872

FIGURE 7.2

BREAK DOWN OF STEEL LABOR HR. ESTIMATES
40KDWT ALTERNATIVES U.S. 1994 ONE TANK

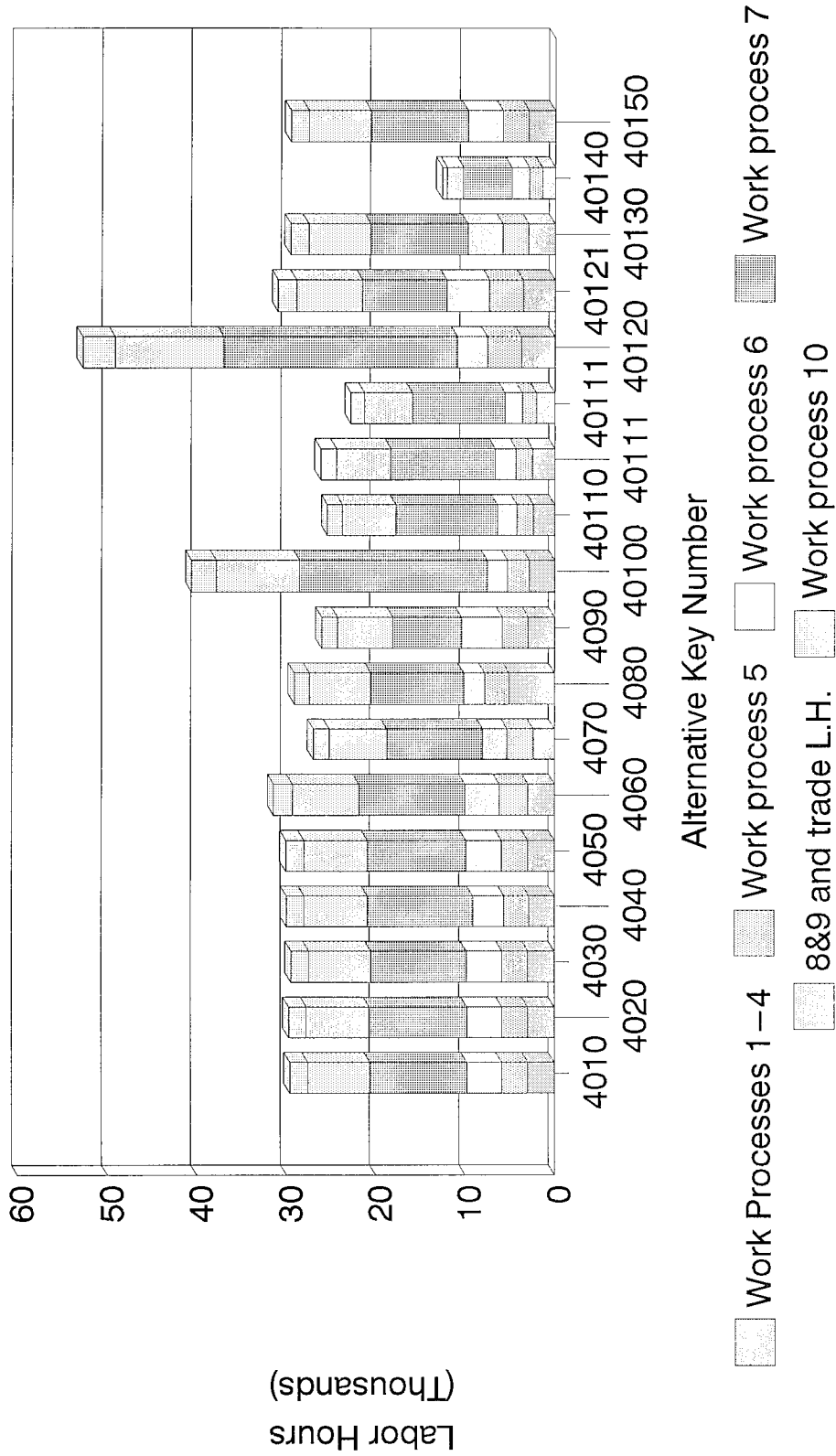
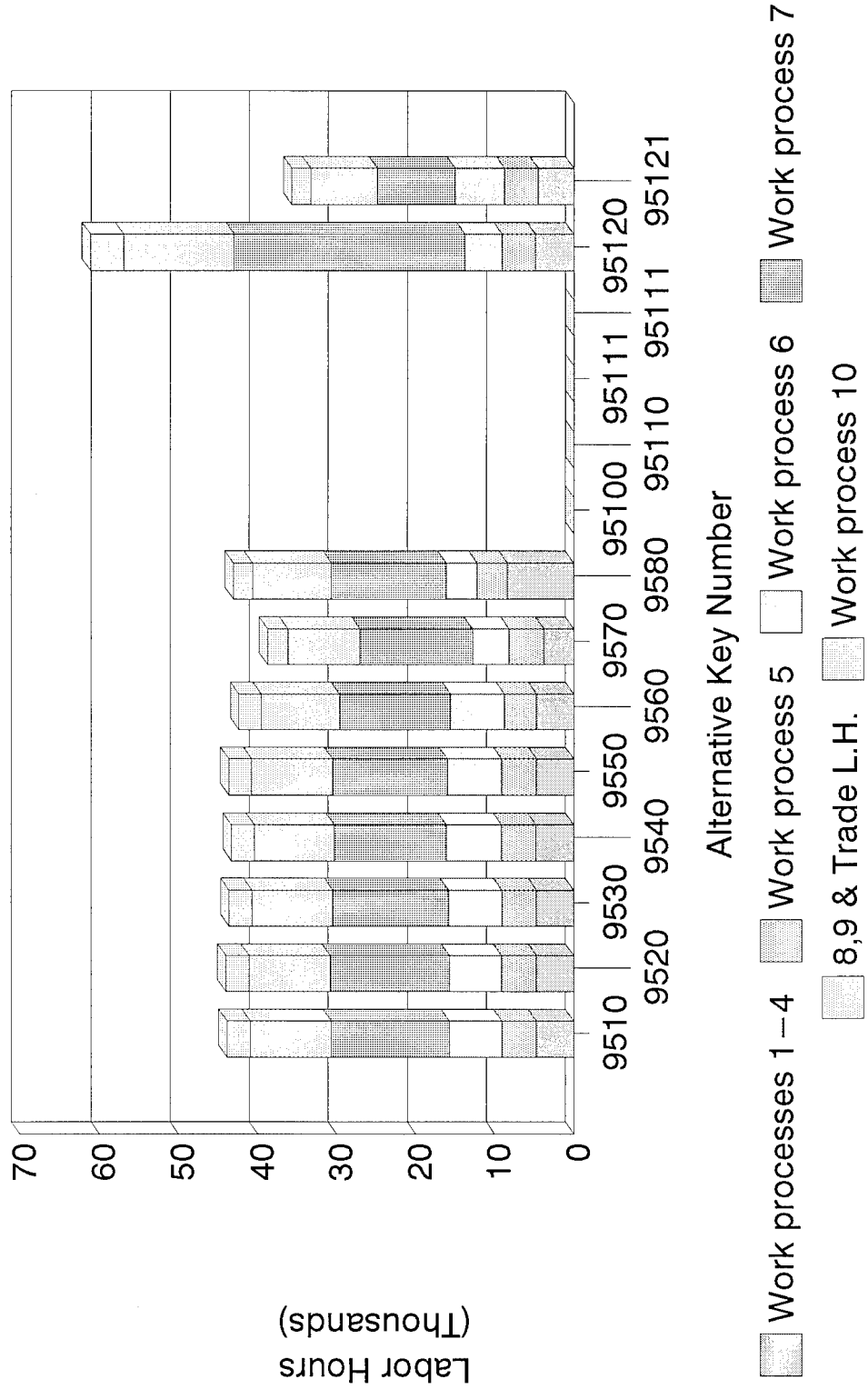

FIGURE 7.3

BREAK DOWN OF STEEL LABOR HR. ESTIMATES
95KDWT ALTERNATIVES U.S. 1994 ONE TANK



As shown in Table 5.10, the estimated steel labor hours for these vessels were 226,464 and 348,755 respectively, based on increased use of automation and accuracy control. The above procedure was therefore applied to the estimated steel labor hours for the midship cargo tanks, obtained as described in paragraph (a), assuming transverse erection butts to be welded automatically instead of manually (in order to give some credit for the increased automation), and using 2½% rework instead of the previously assumed 10%. This resulted in an average excess of labor hours of 43.59%. The reduction of the same process factors as before by 26.50% then gave steel labor hours for the midship tanks which again differed by about ±6% from the initial estimates, which was again considered satisfactory. This result provided further validation of the calibration procedure and also gave some credence to the estimated labor hours for construction in the Far East in 1994. The latter estimates, of course, provided the basis for the later estimates for construction in the U.S.

These steel labor hours were then extended to the complete ships, using the procedure given in paragraph (a). The corresponding total labor hours for the vessels were then obtained by adding in the machinery/outfit labor hours from Table 5.11 and the 50,000 hours for design from Table 5.9. The resulting labor hours for the construction of the 40K and 95KDWT vessels in the Far East in 1994 were 447,480 and 622,057 respectively. For comparison, these results are included in Figures 7.4 and 7.5, and also in the plot of total labor hours given in the Appendix on page A125.

An important result of this analysis is that it highlights the main causes of reduced labor hours in the Far East as being the greater use of automation and accuracy control, together with reduced hours for design.

7.4 LABOR HOURS FOR CONSTRUCTION OF COMPLETE VESSELS

As indicated in Section 7.3, paragraph (a), the steel labor hours for the construction of the midships one tank length alternatives were estimated to be 1/10.49 and 1/9.60 of the total steel labor hours for the 40K and 95Kdwt designs respectively. Therefore, the total steel labor hours for the construction of a complete vessel could be obtained by multiplying the labor hours for one midships tank length by the appropriate factor 10.49 or 9.60.

However, to allow for the transition of cargo tank structure into the bow and stern portions of the vessels, it was decided to maintain the steel labor hours for the construction of N^o1 cargo tank section, the bow and the stern constant for the two sets of vessel sizes and equal to the hours determined for the 40K and 95KDWT base alternatives in these areas. The steel labor hours for the deckhouses were similarly held constant. Thus, from the information derived in Section 7.3, paragraph (a), the constant portion of the steel labor hours for the 40KDWT alternatives was obtained from

$$(10.49 - 5.95) 29,578 = 134,284 \text{ hours.}$$

where 10.49 expresses the ratio of the total steel labor hours for the vessel to those required for the midship cargo tank section and 5.95 expresses a similar ratio for the steel labor hours for N^o2 thru N^o7 cargo tank sections. The corresponding figure for the 95KDWT alternative was obtained from

$$(9.60 - 5.95) 43,872 = 160,133 \text{ hours.}$$

Thus, only the steel labor hours for the construction of N^o2 thru N^o7 cargo tank sections were varied to suit the structural alternatives. These hours were obtained by multiplying the derived labor hours for the construction of the midship tank section for the various alternatives

by 5.95. The total steel labor hours were then obtained by adding the appropriate constant labor hours given above.

As further indicated in Section 7.3, paragraph (a), the machinery/outfitting labor hours required to construct the complete 40K and 95KDWT base vessels were taken to be 41% of the total labor hours (excluding design labor) given in Table 7.1.

Then machinery/outfitting labor hours for the complete 40K and 95KDWT base vessels are 202,540 and 311,911 respectively. All such labor hours were assumed constant for all alternatives with the exception of the labor hours required for painting.

Table 5.8 gives a percentage breakdown of the labor hours required for machinery/outfitting, and indicates that the labor hours required by the Japanese for painting were 31% of the total machinery/outfitting hours for 40KDWT vessels and 34% for 95 KDWT vessels. These percentages were applied to the two base vessels, and for the remaining alternatives, the labor hours for painting were varied in proportion to the surface area of the steel components.

Thus, the constant portions of the machinery/outfitting labor hours for all alternatives are 139,753 for the 40KDWT vessels and 205,861 for the 95KDWT vessels. The total machinery/outfitting labor hours were obtained by adding the appropriate painting hours for the various alternatives to these figures.

Design labor hours for the 40K and 95KDWT alternatives were estimated at 200,000 and 225,000 hours respectively, as indicated in Section 7.2, except for alternative 40150 providing for enhanced standardization where significant detail design data or working drawings are on file, for which they were reduced to 100,000.

The total labor hours for the various alternatives were then obtained by summing up the hours for steel construction, the constant hours for machinery/outfitting, the hours for painting and the hours for design. For the baseline vessels, the resulting total labor hours for the construction of the 40K and 95KDWT alternatives in the U.S. in 1994 were 712,813 and 958,082 respectively. The results of all calculations are shown graphically in Figures 7.4 and 7.5 respectively, and also in the Appendix on page A124.

7.5 CONSTRUCTION SCHEDULES

As indicated in Section 7.2, Figure 7.1 and Table 7.2 provide the estimated construction schedules in a U.S. shipyard for the 40K and 95KDWT baseline vessels. These schedules are a modified version of those provided by Reference [19] for similar vessels building in the Far East. As indicated in Section 7.2, this reference shows almost no difference in schedules for the 40K or 95KDWT vessels, and this is reflected in Table 7.2. The Far East schedule was modified to reflect predicted U.S. attainment in 1994 as follows:

FIGURE 7.4

ESTIMATED 40KDWT SHIP LABOR HOURS
1994 U.S. DESIGN AND CONSTRUCTION

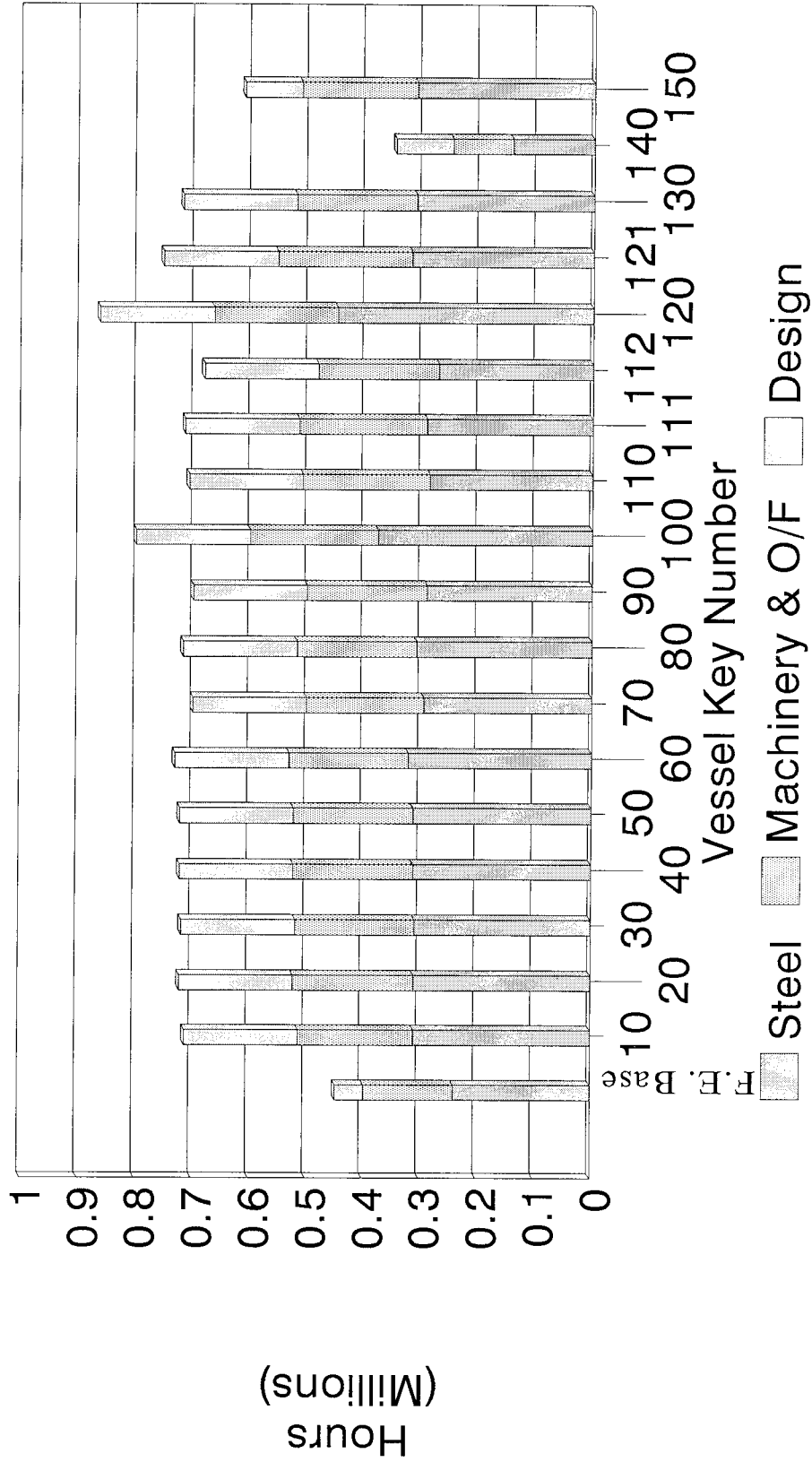
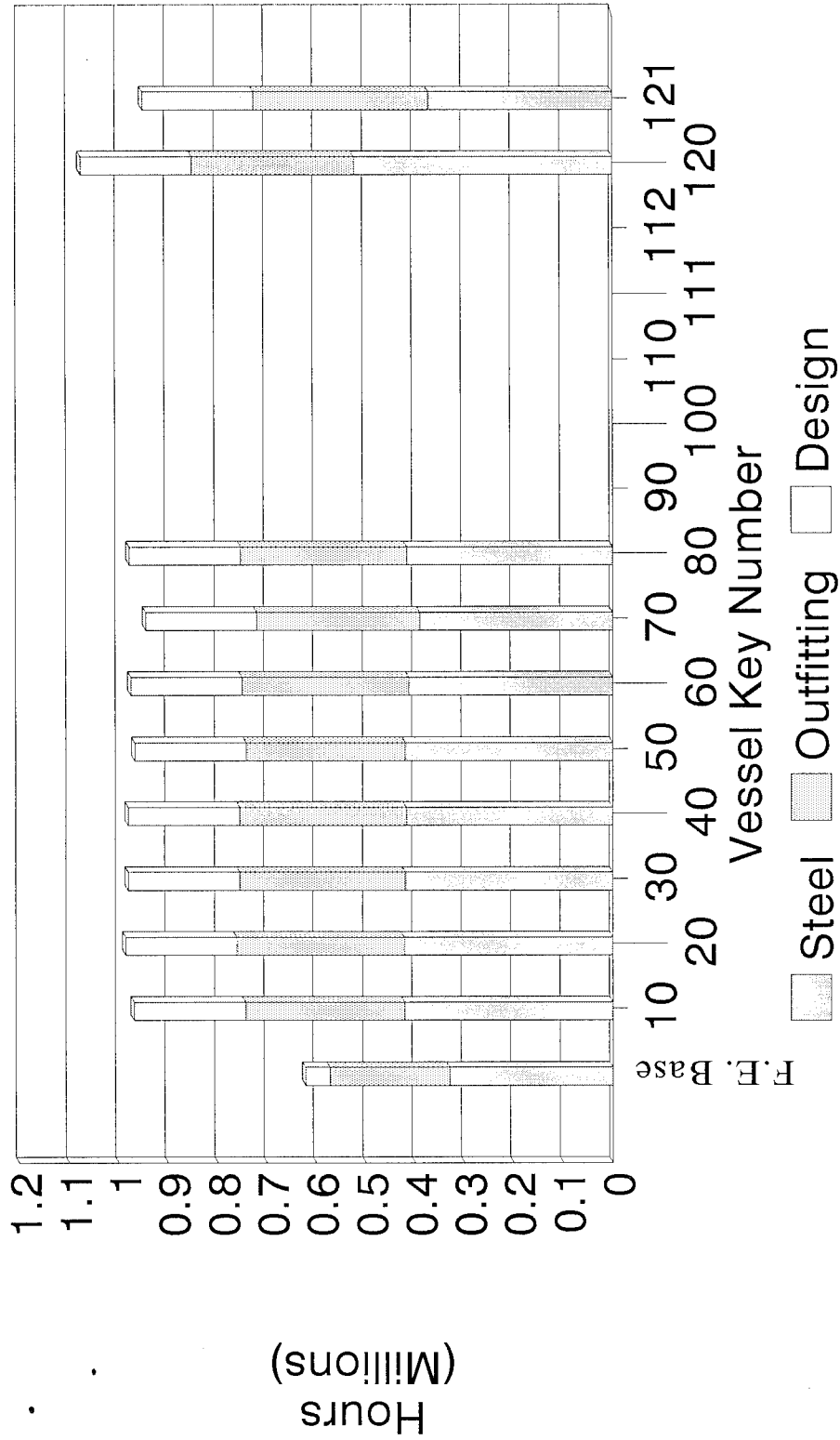

FIGURE 7.5

ESTIMATED 95KDWT SHIP LABOR HOURS
1994 U.S. DESIGN AND CONSTRUCTION



- The design time was increased from 8 months to approximately 14 months (6 months increase) to provide additional design time for one off ships with less incorporation of interim products.
- It is assumed that the time line between the commencement of steel fabrication and trials increases by 2.6 months to allow for the lesser utilization of automation and accuracy control in U.S. shipyards. The figure of 2.6 months was obtained by increasing the Far East schedule of 9 months by the factors $(1/0.84) \times (1/0.925)$ - see Table 7.2.
- The time line between commencement of steel fabrication and launching was increased from 7.4 to 12.4 months, to suit the U.S. construction data for 40KDWT tankers in Figure 5.4. This 5 month increase was overlapped into the design period.
- The time line between sea trials and delivery (3.5 months) was unchanged, assuming the same yard would produce all alternatives with a 3.5 month seatrial to delivery time.

Thus, the U.S. baseline schedule was increased to 29.1 months, and this was used as a basis for the estimation of schedules for the various structural alternatives. Key milestones such as the commencement of fabrication, keel laying and launching are included in Figure 7.1, which also incorporates time lines for assembly, erection and painting. The time spread of these time lines and the locations of the key milestones given in the Far East schedule were modified to suit the above changes. It should be noted that in preparing the basic schedule for construction in U.S. shipyards, it has been assumed that all required material and equipment would be delivered to the shipyard as required to meet the schedule. Any delay in such deliveries would impact on the schedule and increase vessel costs.

For estimating the construction schedules for the various 40K and 95KDWT alternatives, the pertinent information derived from their evaluation for this purpose consisted of the total steel labor hours and the labor hours (or surface areas of steel components) for painting. As indicated in Section 7.4, the machinery and outfitting labor hours for the 40K and 95KDWT base vessels have been assumed constant, with the exception of those required for painting. Therefore, it has been assumed that the time lines for steel assembly and erection are proportional to the total steel labor hours, and the time line for painting is proportional to the labor hours (or surface areas) required for painting. As indicated in Section 7.4, labor hours for painting were varied in proportion to the surface areas, so that either quantity may be used to modify the time line.

As previously stated, the base construction schedule shown in Figure 7.1 shows key milestones in the building process, and since it was considered desirable to include these in all schedules, the following procedure was adopted to estimate the construction schedules for the structural alternatives:

- With reference to Figure 7.1, no change was made to the location of the milestone for the commencement of steel fabrication.
- The time line for steel assembly preceding keel laying was modified in proportion to the total steel labor hours, resulting in relocation of keel laying and all subsequent key milestones.

- The time lines for steel assembly and erection located between keel laying and launching were modified in proportion to the total steel labor hours. The time line for painting preceding launching was modified in proportion to the total painting labor hours. Since these three construction processes overlap in this portion of the schedule, the changes in their corresponding time lines were then averaged to provide the accumulative effect upon the time required between keel laying and launching. Keel laying and all subsequent key milestones were then again relocated to suit.

- The time line for painting following launching was modified in proportion to the total painting labor hours, resulting in further relocation of the milestones for sea trials and ship delivery.

The resulting construction schedules for all of the 40K and 95KDWT structural alternatives are shown in Figures 7.6 and 7.7 respectively. For comparison purposes, the Far East schedule of 20.5 months has also been incorporated in these figures.

7.6 IMPROVEMENTS TO DESIGN AND CONSTRUCTION

The labor hours and construction schedules shown in Figures 7.4, 7.5, 7.6 and 7.7 for baseline vessels constructed in the Far East are considerably smaller than those for the various alternatives constructed in the U.S. and show the effect of increased automation, increased accuracy control and reduced design labor hours, as these were the only variables considered significant in differentiating the U.S. and Far East labor hours and schedules, as discussed in Section 7.2.

In the interest of testing this hypothesis, the automation, accuracy control and design time were improved for alternatives 4010, 4090 and 40110 yielding alternatives 4010N, 4090N and 40110N. The improvements reflect the following:

- Floor and girder stiffeners are assumed automatically welded. Field welds of side shell decks and longitudinal bulkhead are assumed automatically welded.

- Accuracy control improved by careful edge preparation and increased statistical measurements and rework was reduced from 10% to 2%.

- Design labor hours, due to standardization was reduced to 100,000 hours.

A comparison of the alternatives before and after these assumptions are shown in figures 7.8 and 7.9, using the method of evaluations contained herein. They demonstrate that the improvements noted reduce the difference in labor hours between the Far Eastern Baseline and the U.S. constructed vessel is in the order of 12%.

FIGURE 7.6

CONSTRUCTION SCHEDULE
40KDWT ALTERNATIVES
Months

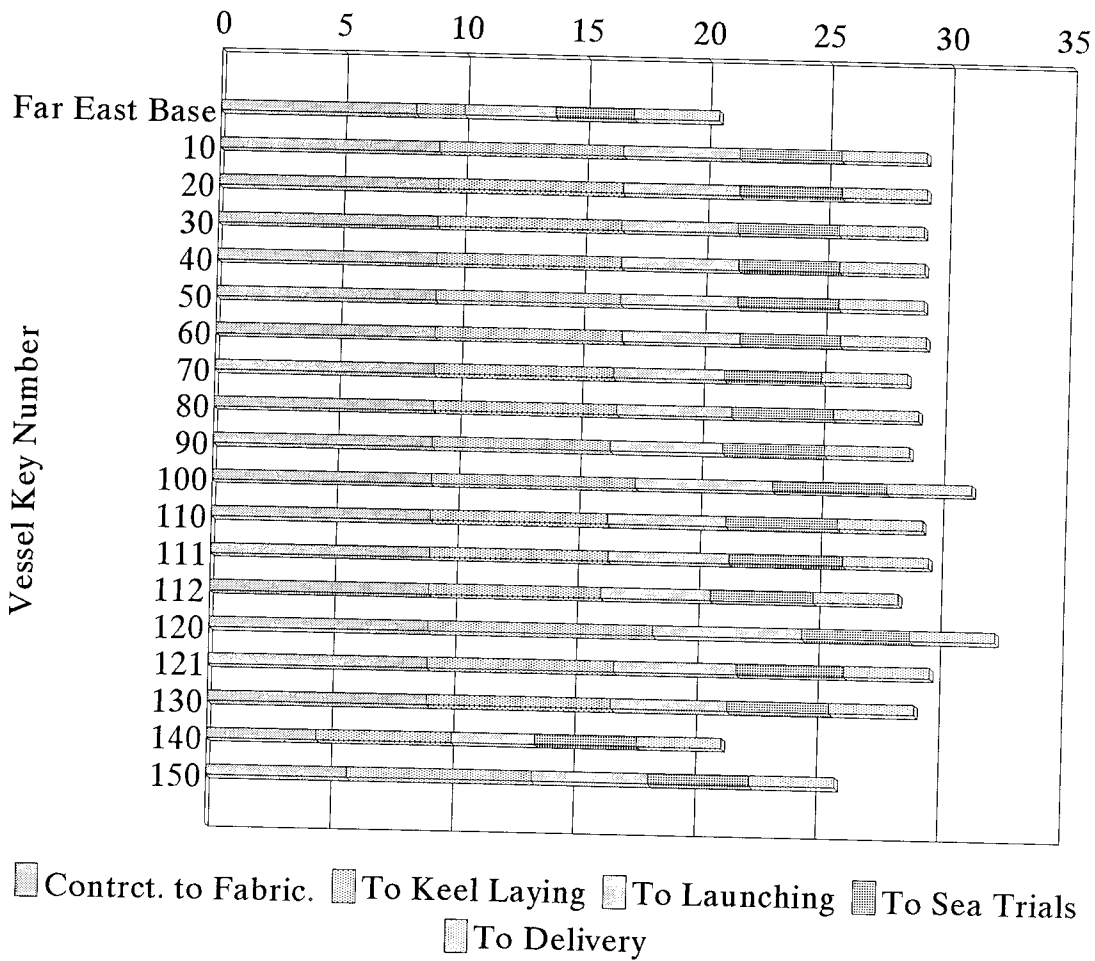

FIGURE 7.7

CONSTRUCTION SCHEDULE
95KDWT ALTERNATIVES
Months

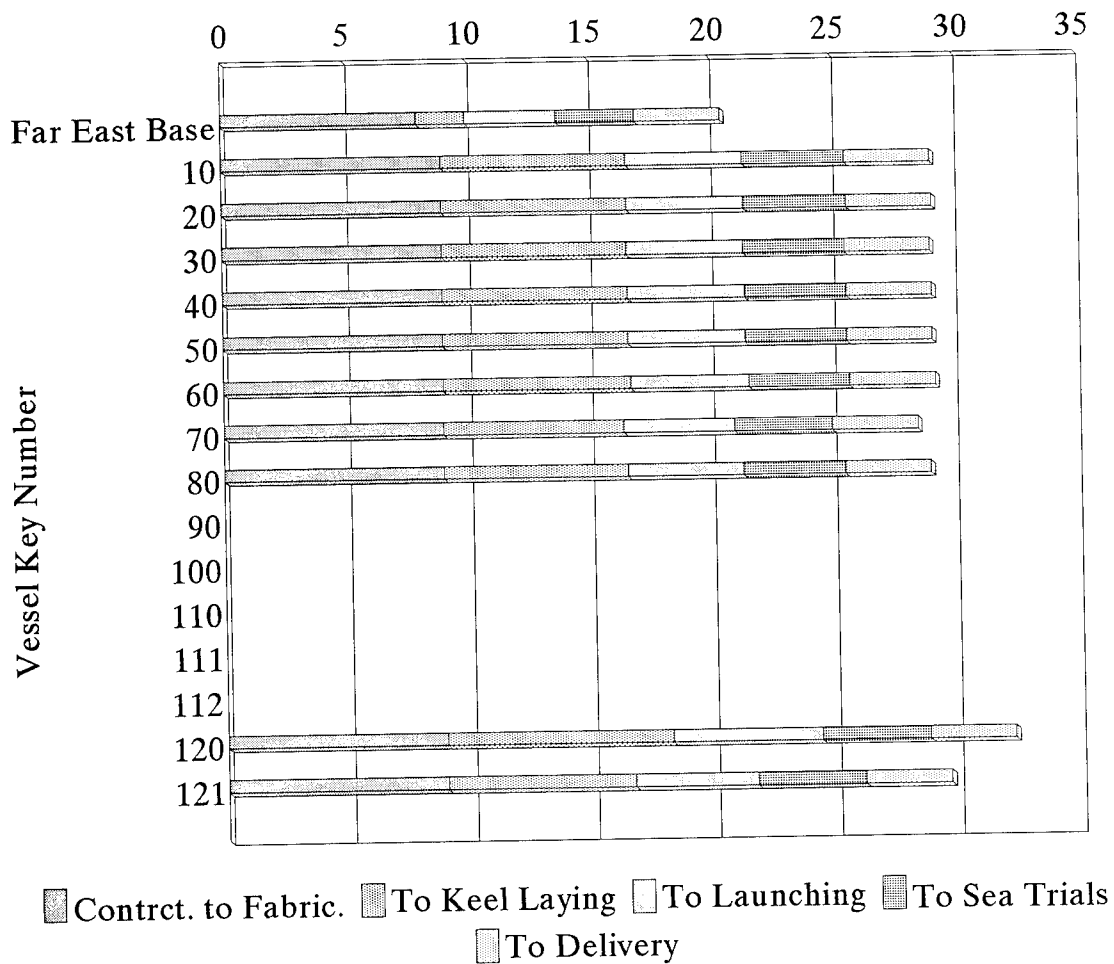
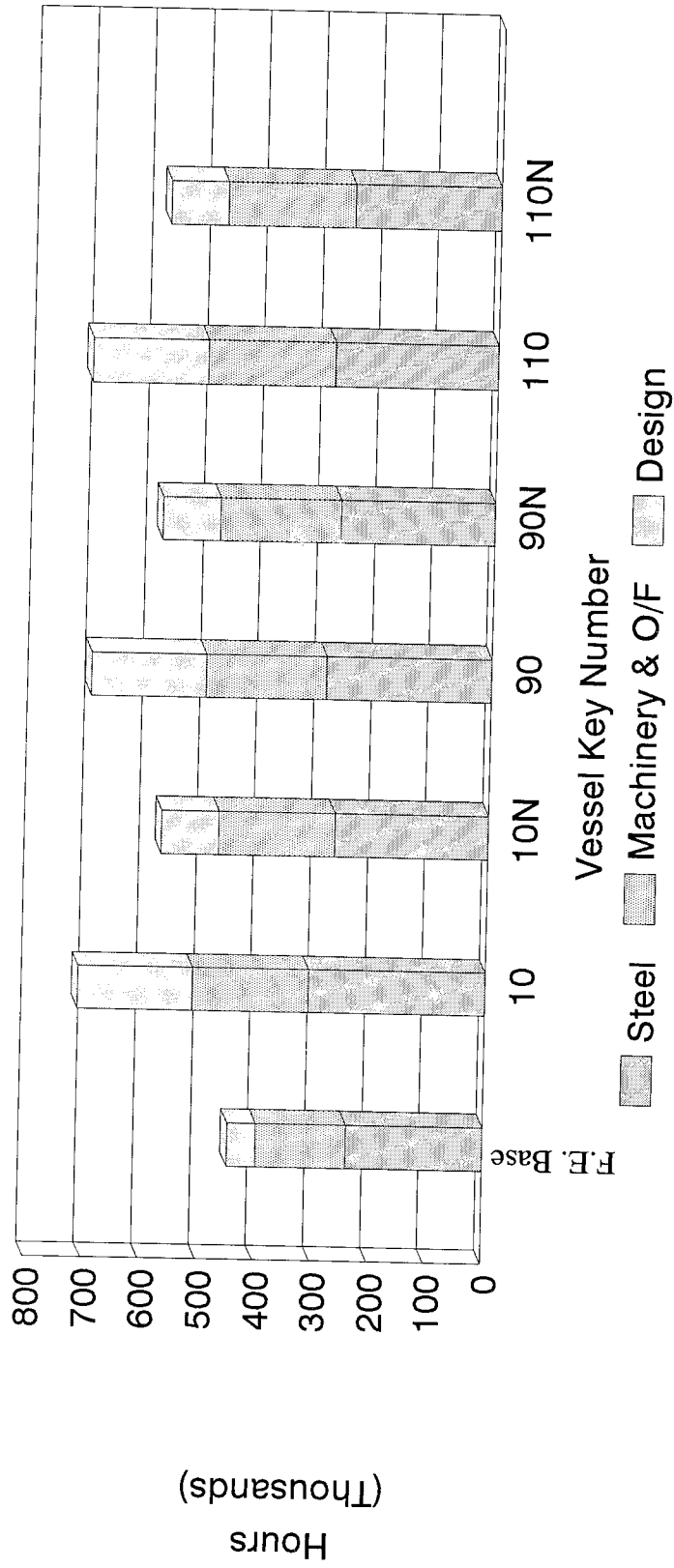

FIGURE 7.8

ESTIMATED 40KDWT SHIP LABOR HOURS
1994 U.S. DESIGN AND CONSTRUCTION



BREAK DOWN OF CUTTING, PREP. AND WELDS
 40KDWT ALTERNATIVES U.S. - ONE TANK

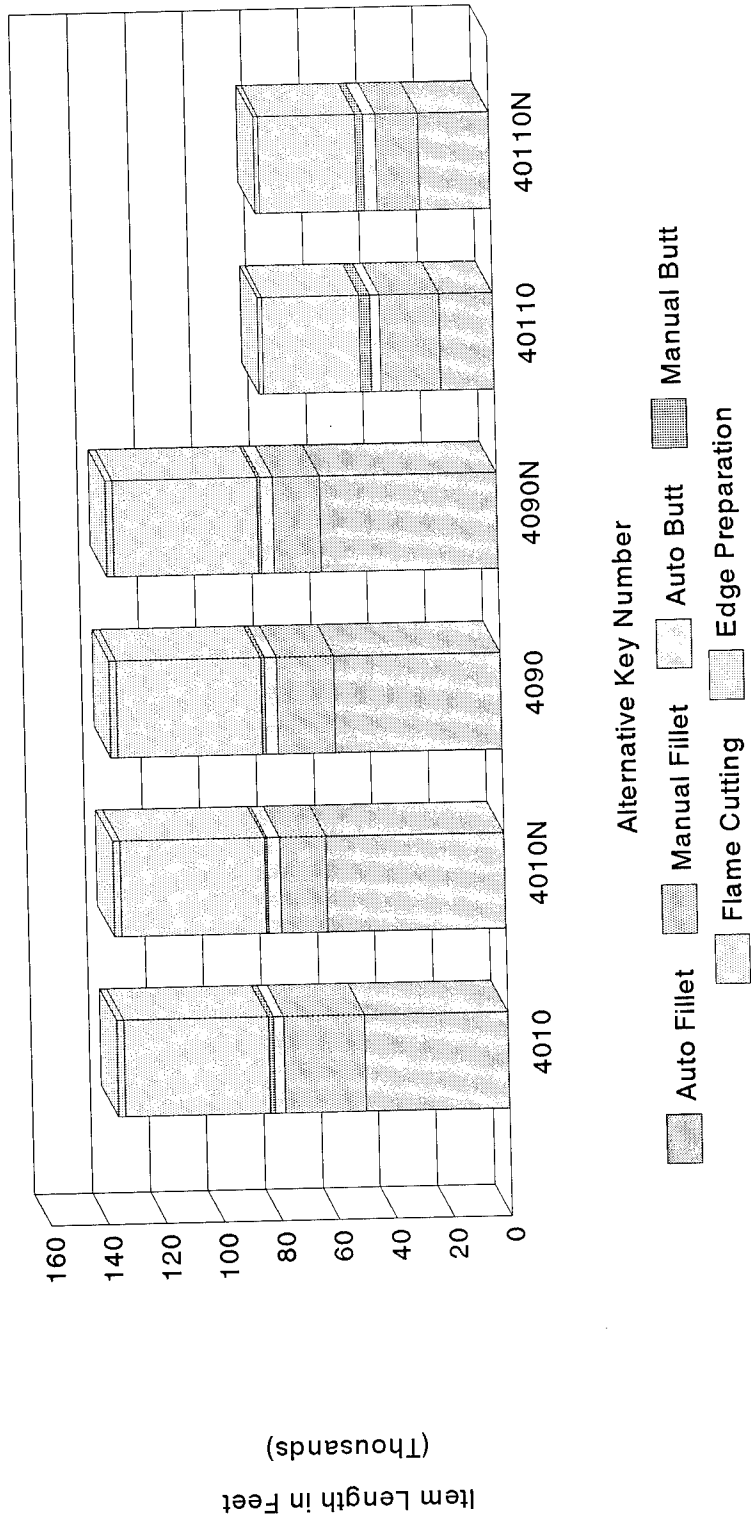

FIGURE 7.9

8.0 CONCLUSIONS

The physical characteristics, estimated in Section 6.0 and the labor hour and construction schedules estimated in Section 7.0, provide a measure of producibility of the alternative structural concepts. The estimated labor hours for construction of the 40KDWT alternatives, shown in Figure 7.4, indicate that the labor hours for most of the alternatives are within 20,000 (about 3% of the 712,813 hours estimated for the baseline alternative 4010). As an example, alternative 4070 shows the benefit (about 10,000 hours reduction) of using rolled sections (bulb plates) in lieu of built-up sections. The results show that the effect of the different structural elements used in the various alternatives is generally small. Exceptions to this trend include unidirectional alternative 40100 (+80,000 hours) and dished plate unidirectional alternatives 40120 (+150,000 hours) and 40121 (+40,000 hours). These results are perhaps surprising, since unidirectional designs incorporate significantly less structural pieces, but the increased labor hours for these vessels appears to be largely due to increased flame cutting/welding hours etc. necessitated by increased plating thickness. Also, as indicated in Section 5.4, the scantlings of dished plate unidirectional alternatives were maintained constant around the entire periphery of the midship section, which again incurs additional labor hours due to oversized scantlings in some areas. More notable exceptions are alternative 40140, which shows the advantage of series production of the baseline vessel, assuming labor hours are halved, and alternative 40150, which shows the advantage of using standard designs for structural details, assuming the design labor hours are halved. Finally, the comparisons in Figures 7.8 and 7.9 represent alternatives where the design hours have been halved, welding automation increased and accuracy control increased to reduce rework to 2%.

The estimated labor hours for construction of the 95KDWT alternatives, shown in Figure 7.5, indicate similar trends relative to the 958,082 hours estimated for the baseline alternative 9510 as exhibited by the 40KDWT alternatives. Labor hours for unidirectional alternative 95100 were not estimated (see Section 5.4), but dished plate alternatives 95120 and 95121 show about +100,000 hours and -10,000 hours relative to the baseline vessel 9510. This shows a somewhat improved level of producibility than that shown by the corresponding 40KDWT vessels.

Further to the increased plating thickness for unidirectional alternatives referred to above, this increase is due to the wider spacing of the longitudinal girders as compared with conventional longitudinal stiffeners. Some reduction in plating thickness is achieved in dished plate unidirectional designs by the adoption of dished plating, but the hull steel weight of both versions of the dished plate hull exceed those of a corresponding conventional double hull design. The advantage of dished plating compared with flat plating may be illustrated by comparing the shell plating thickness for each case, utilizing dished plate alternative 40120 with 2.4M. girder spacing. A thickness of 25.4mm. was estimated for dished plating, but this increased to 45mm. for flat plating. The steel weight of one midship cargo tank length would then increase by 37.6%, and the estimated steel labor hours would increase by 45%.

The construction schedules for the 40KDWT alternatives, shown in Figure 7.6, indicate that the schedules for most of the alternatives are equal to or slightly lower than that of the 29.1 months required for the baseline alternative 4010. Exceptions include 40100, 40120, 40140 and 40150, referred to in the preceding discussion of labor hours. It may be noted that the schedule for 40140 is only slightly greater than the 20.5 months required for construction in the Far East, but of course a similar advantage for series production should be expected to apply there as well. The schedule for 40150 shows a reduction of about 3 months from the schedule for 4010.

Similar trends are exhibited by the construction schedules for the 95KDWT alternatives, shown in Figure 7.7. The schedule for the baseline alternative 9510 is 29.1 months, as for the 40KDWT baseline 4010.

The labor hours and construction schedule shown in Figures 7.4, 7.5, 7.6 and 7.7 for baseline vessels constructed in the Far East are considerably smaller than those for the various alternatives constructed in the U.S. Figures 7.8 and 7.9 demonstrate how improved automation accuracy control and reduced design labor hours can reduce the labor hours significantly. This suggests that these areas are where the greatest gains may be possible to make U.S. shipyards more productive and more competitive on a world scale. It is likely that to maximize such improvements will require facilities enhancements to mimic Table 2.4, which is beyond the scope of this study.

The differences between the design labor hours in Japan and the U.S. can only be explained by the existence of standard ship designs and design standards in Japan, as discussed in Section 4.2, paragraph 23. It should also be noted that the absence of such standards incurs increased risk in time phased material procurement. These differences can also suggest a production labor force which requires fewer drawings for construction, which also suggests standardization.

9.0 ACKNOWLEDGEMENTS

This project is being conducted by M. Rosenblatt & Son, Inc. for the Ship Structure Committee under contract to the U.S. Coast Guard, supported by two consultants, and under the review of the Ship Structure Committee.

The M. Rosenblatt & Son, Inc. (MR&S) team contributing to this project consisted of the authors and Messrs. Hans A. Hofmann, and Ta-Jen (Willie) Wu, along with its consultants Messrs. Louis Chirillo and Roger Kline. Thanks are extended to Ms. Lynn Sloane for preparation of the text.

The authors are grateful for the constructive comments and guidance received from the Ship Structure Committee Project Technical Committee under the chair of Mr. Norman Hammer of MARAD.

A number of individuals from the industry provided valuable discussion and comment during the project. In particular we acknowledge: Dr. James Wilkins, Wilkins Enterprises, Inc.; Mr. Thomas Lamb, Textron Marine Systems, a division of Textron, Inc.; Mr. Roy Johnson, Mobil Oil Corporation; Messrs. John S. Tucker and Thomas Perrine, National Steel and Shipbuilding Company; Mr. Donald Liu, American Bureau of Shipping; Mr. Rik F. van Hemmen, Martin, Ottoway and van Hemmen, Inc.; and Mr. Jeffrey Beach, Carderock Division of the Naval Surface Warfare Center.

10.0 REFERENCES

1. "Design for Production Manual" (Vol's I-III); National Shipbuilding Research Program, December 1985.
2. Daidola, J. C.; "Considerations for Earlier Design for Production"; SNAME/NSRP Symposium, September 1993.
3. Lamb, T.; "Design for Production in Basic Design"; SNAME Spring Meeting/STAR Symposium, 1986.
4. Ichinose, Y. et al; "Product Oriented Material Management"; The National Shipbuilding Research Program, June 1985.
5. NSRP SP-4; "Build Strategy Development Project"; January 1994.
6. Henn, A.L. and Marhoffer, W.R.; "Cost of U.S. Coast Guard Regulations to the U.S. Maritime Industry and Coast Guard Initiatives to Reduce These Costs"; SNAME Journal of Ship Production, November 1993.
7. Kline, R.G.; "Evaluation of Double Skin Hull Structure for a Major Surface Combatant"; SNAME Transactions, 1990.
8. Okamoto, T., et. al.; "Strength Evaluation of Novel Unidirectional-Girder-System Product Oil Carrier by Reliability Analysis"; SNAME, Transactions, 1985.
9. Skaarup, O.; "The Revival of Commercial Shipbuilding in the U.S.A."; SNAME Centennial Meeting, September 1993.
10. "Marc Guardian - A New Generation U.S. Supertanker Proposal"; Royal Institution of Naval Architects, The Naval Architect, May 1993.
11. Nielsen, K.K.; "Modern Ship Design and Production"; Paper 2, ICMES 93, Marine System Design and Operation.
12. Muntjewerf, Ir.J.J.; "Methodical Series Experiments on Cylindrical Bows"; Royal Institution of Naval Architects, Transactions, 1970.
13. NSRP Project N7-91-4; "Tee-Beam Manufacturing Analysis Milestone Report: Design Review Phase".
14. Hills, W.; Buxton, I. L.; Maddison, R.G; "Design for Steelwork Production During the Concept Design Phase", SNAME Journal of Ship Production, August 1990.
15. Bong, H.S.; Hills, W.; Caldwell, J.B.; "Methods of Incorporating Design-for-Production Considerations into Concept Design Investigations"; SNAME Journal of Ship Production, June 1988.
16. NSRP Publication 0371 "North American Shipbuilding Accuracy - Phase II", July 1993.

17. Chirillo, L.D.; "Flexible Standards: An Essential Innovation in Shipyards; SNAME Journal of Ship Production, February 1991.
18. Burmeister & Wain (B&W - N.H. Brix), telefax to MR&S 11/15/93.
19. Maritech Engineering Japan Co. Ltd., Tokyo (H. Kurose) via L. Chirillo to MR&S 10/26/93.
20. Bunch, H.M.; "Comparison of the Construction Planning and Manpower Schedules for Building the PD-214 General Mobilization Ship in a U.S. Shipyard and in a Japanese Shipyard"; SNAME Journal of Ship Production, February 1987.
21. Chirillo, L.D.; "Flexible Standards: An Essential Innovation in Shipyards"; SNAME Journal of Ship Production, February 1991.
22. Frankel, E.G.; "The Path to U.S. Shipbuilding Excellence - Remaking the U.S. into a World Class Competitive Shipbuilding Nation"; SNAME Journal of Ship Production, February 1992.
23. Frankel, E.G.; "Impact of Technological Change on Shipbuilding Productivity"; SNAME Journal of Ship Production, August 1985.
24. Storch, R.L; Gribskov, J.R.; "Accuracy Control for U.S. Shipyards"; SNAME Journal of Ship Production, February 1985.
25. Sormunen J.; "Accuracy Control at Hull Construction"; Diploma Thesis, Lappeenranta University of Technology, Helsinki, Finland, 1986 (in Finnish).
26. Chirillo, L.D.; "Interim Products - An Essential Innovation in Shipyards"; SNAME Journal of Ship Production, August 1985.
27. Chirillo L.D. and Chirillo R.D.; "Shipbuilding is a Science"; Pacific Northwest, SNAME February, 1982.
28. Vaughan R.; "Productivity in Shipbuilding"; North-East Coast Institution of Engineers and Shipbuilders, Transactions, December 1983.
29. "Zosen Year Book 1973-1974"; Tokyo News Service Ltd., p.103.
30. Fax from ABS (Donald Liu) dated May 13, 1994, referencing a paper by Mr. S. Nagatsuka entitled "Expansion of Construction Facilities of Korean Yards and Its Effect". (Published in the *Japan Maritime Research Report* dated April 1994).
31. Kaiji Press dated 23 March, 1994.
32. Storch, R.L.; Hammer, C.P. and Bunch, H.M.; Ship Production; Cornell Maritime Press, 1988.
33. Welding Handbook; 3rd Edition, American Welding Society.
34. American Bureau of Shipping, MR&S Fonecon, 12/8/93.

35. Communication with Carderock Division of Naval Surface Warfare Center, June 1993.
36. Wilkins, J.R.; Kraine, G.L. and Thompson D.H.; "Evaluating the Producibility of Ship Design Alternatives"; SNAME Journal of Ship Production, September 1992.
37. NSRP Report Nº 0352; "Development of Producibility Evaluation Criteria"; 1993.

11.0 BIBLIOGRAPHY OF ADDITIONAL REFERENCES

1. Honda, K.; Tabushi, N.; "The Design of Longitudinal Beam Layout on a Curved Shell Based on the Production-Oriented Design Concept"; 1993 Ship Production Symposium paper.
2. Chaffaut, A., et. al.; "The Rolling of Longitudinally Profiled Plates by GTS Industries (France) and Dillinger Steel Works (Germany)"; 3rd P.L.A.T.E. Seminar U.S.A., May 1993.
3. "Identification of Producibility Inhibitors in Standard NAVSEA Ship Design Practices"; The National Shipbuilding Research Program, NSRP 0388, August, 1993.
4. Sarabia, A.; Gutierrez, R.; "A Return to Merchant Ship Construction: The International Impact of the NSRP and American Technology"; SNAME Journal of Ship Production, February 1992.
5. "Line Heating Operating Manual"; NSRP 0395, April, 1992.
6. Frisch, F.A.P.; "Design/Production Integration and the Industrial Structure"; SNAME Ship Production Symposium, September, 1992.
7. Manninen, M.; Jaatinen, J.; "Productive Method and System to Control Dimensional Uncertainties at Final Assembly Stages in Ship Production"; SNAME Journal of Ship Production, November, 1992.
8. "Integration and implementation of an Advanced Measurement System into the Assembly Process in Support of 'NEAT' Hull Block Construction and Erection"; 0385 NSRP, August 1993.
9. Japanese Shipbuilding Quality Standard (Hull Part) 1991.
10. "ABS Double Hull Tank Vessels"; American Bureau of Shipping, March 1991.
11. "Proceedings of the 1990 Forum on Alternative Tank Vessel Design"; American Petroleum Institute.
12. "Fabrication Accuracy Through Distortion Control in Shipbuilding"; The National Shipbuilding Research Program, September 1990.
13. Kraine, G.L.; Ingvason, S.; "Producibility in Ship Design"; SNAME Journal of Ship Production, November 1990.
14. Kelly, D.S.; "Improvements in Productivity Through Staff Integration"; SNAME Journal of Ship Production, August 1989.
15. Brown, D.; "An Aid to Steel Cost Estimating and Structural Design Optimization"; North East Coast Institution of Engineers and Shipbuilders, Transactions Vol. 104, 1987-1988.

16. Bunch, H.M.; "Comparison of the Construction Planning and Manpower Schedules for Building the PD214 General Mobilization Ship in a Shipyard of the People's Republic of China"; SNAME Journal of Ship Production, February 1988.
17. Bruce, G.J.; "Ship Design for Production - Some U.K. Experience"; SNAME Journal of Ship Production, February 1988.
18. Niernenberg, A.B.; Caronna, S.G.; "Proven Benefits of Advanced Shipbuilding Technology: Actual Case Studies of Recent Comparative Construction Programs"; SNAME Journal of Ship Production, August 1988.
19. Winkle, I. E.; Baird, D.; "Towards More Effective Structural Design through Synthesis and Optimization of Relative Fabrication Costs"; Royal Institution of Naval Architects, Transactions Vol. 128, 1986.
20. "U.S. Shipbuilding Accuracy Phase I"; NSRP 0239, May 1986.
21. Hunt, E. C.; "A Monte Carlo Approach to One-Dimensional Variation Merging for Shipbuilding Accuracy Control"; SNAME Journal of Ship Production, February, 1987
22. Sasaki, H.; "IHI's Experience of Technical Transfer and Some Considerations on Further Productivity Improvement in U.S. Shipyards"; National Shipbuilding Research Program 1987 Ship Symposium, August 1987.
23. Butler, J. D.; Warren, T. R.; "The Establishment of Shipbuilding Construction Tolerances"; SNAME Journal of Ship Production, August, 1987.
24. Di Luca, R.; "An Integrated Procedure for Hull Design and Production"; SNAME Journal of Ship Production, August 1987.
25. Lamb, T.; "Engineering for Ship Production"; SNAME Journal of Ship Production, November 1987.
26. Weirs, B. J.; "The Productivity Problem in U.S. Shipbuilding"; SNAME Journal of Ship Production, February, 1985.
27. Chirillo, L.D.; Chirillo, R.D.; "The History of Modern Shipbuilding Methods: The U.S. - Japan Interchange"; SNAME Journal of Ship Production, February 1985.
28. Storch, R. L.; "Accuracy Control Variation-Merging Equations: A Case Study of Their Application in U.S. Shipyards"; SNAME Journal of Ship Production, May 1985.
29. Steller, M.E.; Dibner, B.; "Rationalization of Shipyard Information Flows for Improved Shipbuilding Productivity"; SNAME Journal of Ship Production, May 1985.
30. "Process Analysis Via Accuracy Control"; National Shipbuilding Research Program, Revised August 1985.
31. Lamb, T.; "Engineering Management for Zone Construction of Ships"; SNAME Journal of Ship Production, November 1985.

32. Vaughan, R.; "Productivity in Shipbuilding"; North East Coast Institution of Engineers and Shipbuilders, Transactions Vol 100, 1983-1984.
33. Baumler, R.J.; Watanabe, T.; Huzimura, H.; "Sea-Land's D9 Containerships: Design, Construction, and Performance"; SNAME Transactions, 1983.
34. "Integrated Hull Construction Outfitting and Painting (IHOP)"; the National Shipbuilding Research Program, 1983.
35. "Product Work Breakdown Structure"; The National Shipbuilding Research Program, 1982.
36. Lowry, R.; Stevens, W.L.; Craggs, J.D.F; "Technology Survey of Major U.S. Shipyards"; SNAME Transactions 1980.
37. Gupta, S.K.; "Comparison of U.S. and Foreign Shipbuilding Practices"; 1980
38. Colton, T.; Mikami, Y.; Bringing Japanese Shipbuilding Ideas to U.S. Shipyards; SNAME, May 1980.
39. "Survey of Structural Tolerances in the United States Commercial Shipbuilding Industry"; Ship Structure Committee, SSC-273, 1978.
40. Masubuchi, K.; Terai, K.; "Assessment of the Japanese Shipbuilding Industry"; SNAME Marine Technology , July 1974.

(THIS PAGE INTENTIONALLY LEFT BLANK)

Appendix

(THIS PAGE INTENTIONALLY LEFT BLANK)

**40KDWT Base Alternative Vessel 4010 Longitudinal
Scantlings with
ABS OMSEC Program**

ABS/OMSEC PROGRAM VERSION 3.02
 (BASED ON PROPOSED ABS RULE CHANGES FOR 1991)
 INP FILE: 4BASE.INP TLB FILE: TABLE2.TLB
 TITLE : 40KDWT BASE W/BKT W/OMSEC SCANTL. 4010

OUTPUT FILE: 4BASE.OUT

TYPE OF VESSEL: OIL CARRIER
 IBCODE : 1 ISCODE : 1 ISTRUT : 0

LBP : 183.00 (METER)
 L(SCANT.) : 181.00 (METER) BILGE RADIUS : 1.90 (METER)
 BREADTH : 31.00 (METER) D. B. HEIGHT : 2.20 (METER)
 DEPTH : 17.70 (METER) DEADRISE : .00 (METER)
 DRAFT : 11.58 (METER) CAMBER : .70 (METER)
 WIDTH_SHEER: 1.71 (METER) GUNWALE RADIUS: .00 (METER)
 WIDTH_KEEL : 1.80 (METER) WIDTH_FLATDECK: 4.00 (METER)
 ZDIST : .00 (METER) WIDTH_FLATBOT.: .00 (METER)
 WIDTH_STRNG: 1.85 (METER)

DISPLACEMENT : 53280. (METRIC TONS)
 BLOCK COEFFICIENT : .800

ASSIGNED		EXTENT OF MATERIAL		YIELD STRESS KG/MM2	ULTIMATE STRESS KG/MM2	Q-FACTOR (6.13.3)
MATERIAL NUMBER	DESC	BOTTOM (METER)	TOP (METER)			
2	AH32	.00	1.90	32.	48.	.780
1	MILD	1.90	16.00	24.	41.	1.000
2	AH32	16.00	18.50	32.	48.	.780

NOMINAL WEB SPACING = 3.58 (METER)
 FLOOR OR SUPPORTING SPACING = 3.58 (METER)

S E C T I O N M O D U L U S

(BASED ON PROPOSED ABS RULE CHANGES FOR 1991)

LENGTH OF VESSEL : 181.00 (METER)
 BREADTH OF VESSEL : 31.00 (METER)
 BLOCK COEFFICIENT : .800

C1 : .945E+01
 C2 : .100E-01

STILL WATER BM (Msw) = 98687.90 (TONS-METERS)
 ABS Wave Sagging BM (Mws) = -161555.00 (TONS-METERS)
 ABS Wave Hogging BM (Mwh) = 148749.60 (TONS-METERS)

BENDING MOMENT (FOR THE DESIGN) = 247437.50 (TONS-METERS)

(6.3.4 A SECTION MODULUS)

FP = 1.784 (MT/CM**2)
 SM = 138698.20 (CM**2-M)

(6.3.4 2. MINIMUM SECTION MODULUS)

C1 = .94519E+01
 SM = 143988.40 (CM**2-M)

(BENDING STRESS AND REQUIRED SECTION MODULUS)

SIGMA B = 1.718 (MT/CM**2)
 SM = 143988.40 (CM**2-M)

(6.3.4 B REQUIRED HULL-GIRDER MOMENT OF INERTIA)

HGMI = 782639.70 (CM**2-M**2)

(VALUES MODIFIED BY Q FACTOR)

	REQ. SECTION MODULUS (CM**2-M)	Q-FACTOR	LIMIT STRESS (MT/CM**2)
TOP	112311.00	.780	2.203
BOTTOM	112311.00	.780	2.203

PLATE SEAM COORDINATES

SHELL

SECTION	DESCRIPTION	NODE	GIRTHS (METER)	Y-COORD (METER)	Z-COORD (METER)
1	BOTTOM	1	.00	.00	.00
1	BOTTOM	2	1.80	1.80	.00
1	BOTTOM	3	4.57	4.57	.00
1	BOTTOM	4	9.14	9.14	.00
1	BOTTOM	5	13.30	13.30	.00
1	BOTTOM	6	13.60	13.60	.00
1	BOTTOM	7	16.58	15.50	1.90
2	SIDE	1	.00	15.50	1.90
2	SIDE	2	.30	15.50	2.20
2	SIDE	3	4.20	15.50	6.10
2	SIDE	4	11.42	15.50	13.32
2	SIDE	5	14.10	15.50	16.00
2	SIDE	6	15.80	15.50	17.70
3	MAIN DECK	1	.00	15.50	17.70
3	MAIN DECK	2	1.85	13.65	17.81
3	MAIN DECK	3	2.20	13.30	17.83
3	MAIN DECK	4	11.52	4.00	18.40
3	MAIN DECK	5	15.52	.00	18.40
4	INNER BOTTOM	1	.00	.00	2.20
4	INNER BOTTOM	2	4.57	4.57	2.20
4	INNER BOTTOM	3	9.14	9.14	2.20
4	INNER BOTTOM	4	13.30	13.30	2.20
4	INNER BOTTOM	5	15.50	15.50	2.20
5	BULKHEAD	1	.00	.00	2.20
5	BULKHEAD	2	3.00	.00	5.20
5	BULKHEAD	3	6.00	.00	8.20
5	BULKHEAD	4	9.00	.00	11.20
5	BULKHEAD	5	12.00	.00	14.20
5	BULKHEAD	6	16.20	.00	18.40
6	BULKHEAD	1	.00	13.30	2.20
6	BULKHEAD	2	3.00	13.30	5.20
6	BULKHEAD	3	6.00	13.30	8.20
6	BULKHEAD	4	9.00	13.30	11.20
6	BULKHEAD	5	12.00	13.30	14.20
6	BULKHEAD	6	15.63	13.30	17.83

(BASED ON PROPOSED ABS RULE CHANGES FOR 1991)

INP FILE: 4BASE.INP TLB FILE: TABLE2.TLB

OUTPUT FILE: 4BASE.OUT

TITLE : 40KDWT BASE W/BKT W/OMSEC SCANTL.

 PLATE AREA, MOMENT, AND INERTIA /UNIT THICKNESS

SHELL SECTION	DESCRIPTION	PLATE	AREA (METER)	MOMENT (M**2)	INERTIA (M**3)
1	BOTTOM	1	1.80	.00	.0
1	BOTTOM	2	2.77	.00	.0
1	BOTTOM	3	4.57	.00	.0
1	BOTTOM	4	4.16	.00	.0
1	BOTTOM	5	.30	.00	.0
1	BOTTOM	6	2.98	2.06	2.4
2	SIDE	1	.30	.62	1.3
2	SIDE	2	3.90	16.18	72.1
2	SIDE	3	7.22	70.11	712.1
2	SIDE	4	2.68	39.21	576.3
2	SIDE	5	1.70	28.72	484.4
3	MAIN DECK	1	1.85	32.85	583.3
3	MAIN DECK	2	.35	6.31	112.5
3	MAIN DECK	3	9.32	168.80	3058.4
3	MAIN DECK	4	4.00	73.60	1354.2
4	INNER BOTTOM	1	4.57	10.05	22.1
4	INNER BOTTOM	2	4.57	10.05	22.1
4	INNER BOTTOM	3	4.16	9.15	20.1
4	INNER BOTTOM	4	2.20	4.84	10.6
5	BULKHEAD	1	1.50	5.55	21.7
5	BULKHEAD	2	1.50	10.05	68.5
5	BULKHEAD	3	1.50	14.55	142.3
5	BULKHEAD	4	1.50	19.05	243.1
5	BULKHEAD	5	2.10	34.23	561.0
6	BULKHEAD	1	3.00	11.10	43.3
6	BULKHEAD	2	3.00	20.10	136.9
6	BULKHEAD	3	3.00	29.10	284.5
6	BULKHEAD	4	3.00	38.10	486.1
6	BULKHEAD	5	3.63	58.20	936.3

ABS/OMSEC PROGRAM VERSION 3.02
 (BASED ON PROPOSED ABS RULE CHANGES FOR 1991)
 INP FILE: 4BASE.INP TLB FILE: TABLE2.TLB
 TITLE : 40KDWT BASE W/BKT W/OMSEC SCANTL.

OUTPUT FILE: 4BASE.OUT

BOTTOM GIRDERS -

ITEM	X-ORD.	Y-ORD.	WEB H	WEB T	FACE W	FACE T	AREA	ARM	XI0
1	.00	.00	2200.	13.	0.	0.	28600.	1.10	11535.
2	4.57	.00	2200.	13.	0.	0.	57200.	1.10	23071.
3	9.14	.00	2200.	13.	0.	0.	57200.	1.10	23071.
4	13.30	.00	2200.	13.	0.	0.	57200.	1.10	23071.

SIDE STRINGERS -

ITEM	X-ORD.	Y-ORD.	PLT L	PLT T	AREA	ARM	XI0
1	15.50	6.10	2200.	13.	57200.	6.10	0.
2	15.50	13.32	2200.	13.	57200.	13.32	0.

LONGITUDIAL PLATE - 0.4L AMIDSHIPS

SHELL SECTION	ELE.	MAT'L	PLATE KG/M2	THICKNESS (MM)		LENGTH (METER)	FRAMED
				DESIGN	LOCAL RULE (REQ'D)		
KEEL PLATE	1	AH32	125.60	16.000	(16.000)	1.80	LONGITUDINAL
BOTTOM	2	AH32	113.82	14.500	(14.500)	2.77	LONGITUDINAL
BOTTOM	3	AH32	113.82	14.500	(14.500)	4.57	LONGITUDINAL
BOTTOM	4	AH32	113.82	14.500	(14.500)	4.16	LONGITUDINAL
BOTTOM	5	AH32	113.82	14.500	(14.500)	.30	LONGITUDINAL
BOTTOM	6	AH32	113.82	14.500	(14.500)	2.98	LONGITUDINAL
SIDE	1	MILD	117.75	15.000	(15.000)	.30	LONGITUDINAL
SIDE	2	MILD	117.75	15.000	(15.000)	3.90	LONGITUDINAL
SIDE	3	MILD	117.75	15.000	(15.000)	7.22	LONGITUDINAL
SIDE	4	MILD	117.75	15.000	(15.000)	2.68	LONGITUDINAL
SHEERSTRAKE	5	AH32	113.82	14.500	(14.500)	1.70	LONGITUDINAL
STRINGER	1	AH32	113.82	14.500	(14.500)	1.85	LONGITUDINAL
MAIN DECK	2	AH32	113.82	14.500	(14.500)	.35	LONGITUDINAL
MAIN DECK	3	AH32	113.82	14.500	(14.500)	9.32	LONGITUDINAL
MAIN DECK	4	AH32	113.82	14.500	(14.500)	4.00	LONGITUDINAL
INNER BOTTOM	1	MILD	121.67	15.500	(15.500)	4.57	LONGITUDINAL
INNER BOTTOM	2	MILD	121.67	15.500	(15.500)	4.57	LONGITUDINAL
INNER BOTTOM	3	MILD	121.67	15.500	(15.500)	4.16	LONGITUDINAL
INNER BOTTOM	4	MILD	121.67	15.500	(15.500)	2.20	LONGITUDINAL
BULKHEAD	1	MILD	117.75	15.000	(15.000)	3.00	LONGITUDINAL
BULKHEAD	2	MILD	109.90	14.000	(14.000)	3.00	LONGITUDINAL
BULKHEAD	3	MILD	98.13	12.500	(12.500)	3.00	LONGITUDINAL
BULKHEAD	4	MILD	78.50	10.000	(2.500)	3.00	LONGITUDINAL
BULKHEAD	5	AH32	113.82	14.500	(14.500)	4.20	LONGITUDINAL
BULKHEAD	1	MILD	117.75	15.000	(15.000)	3.00	LONGITUDINAL
BULKHEAD	2	MILD	109.90	14.000	(14.000)	3.00	LONGITUDINAL
BULKHEAD	3	MILD	98.13	12.500	(12.500)	3.00	LONGITUDINAL
BULKHEAD	4	MILD	78.50	10.000	(2.500)	3.00	LONGITUDINAL
BULKHEAD	5	AH32	113.82	14.500	(14.500)	3.63	LONGITUDINAL

LONGITUDINAL STIFFENER SCANTLINGS - 0.4L AMIDSHIPS

SECTION NO. = 1 (BOTTOM) NOMINAL SPACING = .800

NO	MAT'L	SCANTLINGS	AREA	PLATE THK	PLATE EFW	Y-ORD.	Z-ORD.	RULE SM (ABS)	CALC. SM
1	AH32	400X100X13X18	7000.	16.0	800.	.80	.00	1067.	1314.
2	AH32	400X100X13X18	7000.	16.0	800.	1.60	.00	1067.	1314.
3	AH32	400X100X13X18	7000.	14.5	800.	2.40	.00	1067.	1301.
4	AH32	400X100X13X18	7000.	14.5	800.	3.20	.00	1067.	1301.
5	AH32	400X100X13X18	7000.	14.5	800.	4.00	.00	1067.	1301.
6	AH32	400X100X13X18	7000.	14.5	800.	5.37	.00	1067.	1301.
7	AH32	400X100X13X18	7000.	14.5	800.	6.17	.00	1067.	1301.
8	AH32	400X100X13X18	7000.	14.5	800.	6.97	.00	1067.	1301.
9	AH32	400X100X13X18	7000.	14.5	800.	7.77	.00	1067.	1301.
10	AH32	400X100X13X18	7000.	14.5	800.	8.57	.00	1067.	1301.
11	AH32	400X100X13X18	7000.	14.5	800.	9.94	.00	1067.	1301.
12	AH32	400X100X13X18	7000.	14.5	800.	10.74	.00	1067.	1301.
13	AH32	400X100X13X18	7000.	14.5	800.	11.54	.00	1067.	1301.
14	AH32	400X100X13X18	7000.	14.5	800.	12.34	.00	1067.	1301.
15	AH32	400X100X13X18	7000.	14.5	800.	13.60	.00	1067.	1301.

SECTION NO. = 2 (SIDE) NOMINAL SPACING = .780

NO	MAT'L	SCANTLINGS	AREA	PLATE THK	PLATE EFW	Y-ORD.	Z-ORD.	RULE SM (ABS)	CALC. SM
1	AH32	350X100X12X17	5900.	15.0	780.	15.50	1.90	936.	1019.
2	MILD	400X100X13X18	7000.	15.0	780.	15.50	2.98	1124.	1303.
3	MILD	400X100X13X18	7000.	15.0	780.	15.50	3.76	1070.	1303.
4	MILD	350X100X12X17	5900.	15.0	780.	15.50	4.54	1015.	1019.
5	MILD	350X100X12X17	5900.	15.0	780.	15.50	5.32	960.	1019.
6	MILD	350X100X12X17	5900.	15.0	780.	15.50	6.88	851.	1019.
7	MILD	350X100X12X17	5900.	15.0	780.	15.50	7.66	796.	1019.
8	MILD	350X100X12X17	5900.	15.0	780.	15.50	8.44	741.	1019.
9	MILD	300X90X11X16	4740.	15.0	780.	15.50	9.22	686.	728.
10	MILD	300X90X11X16	4740.	15.0	780.	15.50	10.00	632.	728.
11	MILD	300X90X11X16	4740.	15.0	780.	15.50	10.78	577.	728.
12	MILD	250X90X10X15	3850.	15.0	780.	15.50	11.56	522.	532.
13	MILD	250X90X10X15	3850.	15.0	780.	15.50	12.34	467.	532.
14	MILD	250X90X10X15	3850.	15.0	780.	15.50	14.10	344.	532.
15	MILD	250X90X10X15	3850.	15.0	780.	15.50	14.88	289.	532.
16	MILD	250X90X10X15	3850.	15.0	780.	15.50	15.66	234.	532.
17	AH32	250X90X10X15	3850.	14.5	780.	15.50	16.44	140.	531.
18	AH32	250X90X10X15	3850.	14.5	780.	15.50	17.22	97.	531.

(BASED ON PROPOSED ABS RULE CHANGES FOR 1991)

INP FILE: 4BASE.INP

TLB FILE: TABLE2.TLB

OUTPUT FILE: 4BASE.OUT

TITLE : 40KDWT BASE W/BKT W/OMSEC SCANTL.

LONGITUDINAL STIFFENER SCANTLINGS - 0.4L AMIDSHIPS

SECTION NO. = 3 (MAIN DECK) NOMINAL SPACING = .800

NO	MAT'L	SCANTLINGS	AREA	PLATE THK	PLATE EFW	Y-ORD.	Z-ORD.	RULE SM (ABS)	CALC. SM
1	AH32	200X15	3000.	14.5	800.	14.70	17.75	190.	203.
2	AH32	200X15	3000.	14.5	800.	13.90	17.80	190.	203.
3	AH32	200X15	3000.	14.5	800.	12.50	17.88	190.	203.
4	AH32	200X15	3000.	14.5	800.	11.70	17.93	190.	203.
5	AH32	200X15	3000.	14.5	800.	10.90	17.98	190.	203.
6	AH32	200X15	3000.	14.5	800.	10.11	18.03	190.	203.
7	AH32	200X15	3000.	14.5	800.	9.31	18.08	190.	203.
8	AH32	200X15	3000.	14.5	800.	8.51	18.13	190.	203.
9	AH32	200X15	3000.	14.5	800.	7.71	18.17	190.	203.
10	AH32	200X15	3000.	14.5	800.	6.91	18.22	190.	203.
11	AH32	200X15	3000.	14.5	800.	6.11	18.27	190.	203.
12	AH32	200X15	3000.	14.5	800.	5.31	18.32	190.	203.
13	AH32	200X15	3000.	14.5	800.	4.52	18.37	190.	203.
14	AH32	200X15	3000.	14.5	800.	3.72	18.40	190.	203.
15	AH32	200X15	3000.	14.5	800.	2.92	18.40	190.	203.
16	AH32	200X15	3000.	14.5	800.	2.12	18.40	190.	203.
17	AH32	200X15	3000.	14.5	800.	1.32	18.40	190.	203.
18	AH32	200X15	3000.	14.5	800.	.52	18.40	190.	203.

SECTION NO. = 4 (INNER BOTTOM) NOMINAL SPACING = .800

NO	MAT'L	SCANTLINGS	AREA	PLATE THK	PLATE EFW	Y-ORD.	Z-ORD.	RULE SM (ABS)	CALC. SM
1	MILD	450X150X11.5X15	7425.	15.5	800.	.80	2.20	1435.	1669.
2	MILD	450X150X11.5X15	7425.	15.5	800.	1.60	2.20	1435.	1669.
3	MILD	450X150X11.5X15	7425.	15.5	800.	2.40	2.20	1435.	1669.
4	MILD	450X150X11.5X15	7425.	15.5	800.	3.20	2.20	1435.	1669.
5	MILD	450X150X11.5X15	7425.	15.5	800.	4.00	2.20	1435.	1669.
6	MILD	450X150X11.5X15	7425.	15.5	800.	5.37	2.20	1435.	1669.
7	MILD	450X150X11.5X15	7425.	15.5	800.	6.17	2.20	1435.	1669.
8	MILD	450X150X11.5X15	7425.	15.5	800.	6.97	2.20	1435.	1669.
9	MILD	450X150X11.5X15	7425.	15.5	800.	7.77	2.20	1435.	1669.
10	MILD	450X150X11.5X15	7425.	15.5	800.	8.57	2.20	1435.	1669.
11	MILD	450X150X11.5X15	7425.	15.5	800.	9.94	2.20	1435.	1669.
12	MILD	450X150X11.5X15	7425.	15.5	800.	10.74	2.20	1435.	1669.
13	MILD	450X150X11.5X15	7425.	15.5	800.	11.54	2.20	1435.	1669.
14	MILD	450X150X11.5X15	7425.	15.5	800.	12.34	2.20	1435.	1669.
15	MILD	450X150X11.5X15	7425.	15.5	800.	14.10	2.20	1435.	1669.
16	MILD	450X150X11.5X15	7425.	15.5	800.	14.90	2.20	1435.	1669.

(BASED ON PROPOSED ABS RULE CHANGES FOR 1991)

INP FILE: 4BASE.INP

TLB FILE: TABLE2.TLB

OUTPUT FILE: 4BASE.OUT

TITLE : 40KDWT BASE W/BKT W/OMSEC SCANTL.

LONGITUDINAL STIFFENER SCANTLINGS - 0.4L AMIDSHIPS

SECTION NO. = 5 (BULKHEAD) NOMINAL SPACING = .780

NO	MAT'L	SCANTLINGS	AREA	PLATE THK	PLATE EFW	Y-ORD.	Z-ORD.	RULE SM (ABS)	CALC. SM
1	MILD	400X100X13X18	7000.	15.0	780.	.00	2.98	1204.	1303.
2	MILD	400X100X13X18	7000.	15.0	780.	.00	3.76	1150.	1303.
3	MILD	400X100X13X18	7000.	15.0	780.	.00	4.54	1095.	1303.
4	MILD	400X100X13X18	7000.	14.0	780.	.00	5.32	1040.	1293.
5	MILD	350X100X12X17	5900.	14.0	780.	.00	6.10	985.	1012.
6	MILD	350X100X12X17	5900.	14.0	780.	.00	6.88	931.	1012.
7	MILD	350X100X12X17	5900.	14.0	780.	.00	7.66	876.	1012.
8	MILD	350X100X12X17	5900.	12.5	780.	.00	8.44	821.	1001.
9	MILD	350X100X12X17	5900.	12.5	780.	.00	9.22	766.	1001.
10	MILD	300X90X11X16	4740.	12.5	780.	.00	10.00	712.	716.
11	MILD	300X90X11X16	4740.	12.5	780.	.00	10.78	657.	716.
12	MILD	300X90X11X16	4740.	10.0	780.	.00	11.56	602.	702.
13	MILD	300X90X11X16	4740.	10.0	780.	.00	12.34	547.	702.
14	MILD	250X90X10X15	3850.	10.0	780.	.00	13.12	493.	514.
15	MILD	250X90X10X15	3850.	10.0	780.	.00	13.90	438.	514.
16	MILD	250X90X10X15	3850.	14.5	780.	.00	14.68	383.	531.
17	MILD	250X90X10X15	3850.	14.5	780.	.00	15.46	328.	531.
18	AH32	250X90X10X15	3850.	14.5	780.	.00	16.24	213.	531.
19	AH32	250X90X10X15	3850.	14.5	780.	.00	17.02	171.	531.
20	AH32	250X90X10X15	3850.	14.5	780.	.00	17.80	128.	531.

LONGITUDINAL STIFFENER SCANTLINGS - 0.4L AMIDSHIPS

SECTION NO. = 6 (BULKHEAD) NOMINAL SPACING = .780

NO	MAT'L	SCANTLINGS	AREA	PLATE THK	PLATE EFW	Y-ORD.	Z-ORD.	RULE SM (ABS)	CALC. SM
1	MILD	400X100X13X18	7000.	15.0	780.	13.30	2.98	1204.	1303.
2	MILD	400X100X13X18	7000.	15.0	780.	13.30	3.76	1150.	1303.
3	MILD	400X100X13X18	7000.	15.0	780.	13.30	4.54	1095.	1303.
4	MILD	400X100X13X18	7000.	14.0	780.	13.30	5.32	1040.	1293.
5	MILD	350X100X12X17	5900.	14.0	780.	13.30	6.10	985.	1012.
6	MILD	350X100X12X17	5900.	14.0	780.	13.30	6.88	931.	1012.
7	MILD	350X100X12X17	5900.	14.0	780.	13.30	7.66	876.	1012.
8	MILD	350X100X12X17	5900.	12.5	780.	13.30	8.44	821.	1001.
9	MILD	350X100X12X17	5900.	12.5	780.	13.30	9.22	766.	1001.
10	MILD	300X90X11X16	4740.	12.5	780.	13.30	10.00	712.	716.
11	MILD	300X90X11X16	4740.	12.5	780.	13.30	10.78	657.	716.
12	MILD	300X90X11X16	4740.	10.0	780.	13.30	11.56	602.	702.
13	MILD	300X90X11X16	4740.	10.0	780.	13.30	12.34	547.	702.
14	MILD	250X90X10X15	3850.	10.0	780.	13.30	13.12	493.	514.
15	MILD	250X90X10X15	3850.	10.0	780.	13.30	13.90	438.	514.
16	MILD	250X90X10X15	3850.	14.5	780.	13.30	14.68	383.	531.
17	MILD	250X90X10X15	3850.	14.5	780.	13.30	15.46	328.	531.
18	AH32	250X90X10X15	3850.	14.5	780.	13.30	16.24	213.	531.
19	AH32	250X90X10X15	3850.	14.5	780.	13.30	17.02	171.	531.

SUMMARY OF LONGITUDINAL MATERIAL - 0.4L AMIDSHIPS

SECTION	DESCRIPTION	P L A T E		LONGITUDINAL		SECTION
		AREA (MM-M)	(MT/M)	AREA (MM-M)	(MT/M)	(MT/M)
1	BOTTOM	243.18	1.91	105.00	.82	2.73
2	SIDE	236.15	1.85	90.57	.71	2.56
3	MAIN DECK	225.06	1.77	54.00	.42	2.19
4	INNER BOTTOM	240.25	1.89	118.80	.93	2.82
5	BULKHEAD	107.70	.85	51.71	.41	1.25
6	BULKHEAD	207.19	1.63	99.56	.78	2.41
SUB-TOTAL---		1259.52	9.89	519.64	4.08	13.97
						DECK GIRDERS .00
						BOTTOM GIRDERS .79
						SIDE STRINGERS .45
						MISC. VERT. PLTS .00
						(ONE SIDE) TOTAL 15.20
						TOTAL 30.40

TOTAL WEIGHT OF LONG'L MATERIAL - 0.4L AMIDSHIPS

0.4L AMIDSHIPS = 72.40 (M)
 STEEL WEIGHT = 2201.13 (MT)

ABS/OMSEC PROGRAM VERSION 3.02
 (BASED ON PROPOSED ABS RULE CHANGES FOR 1991)
 INP FILE: 4BASE.INP TLB FILE: TABLE2.TLB
 TITLE : 40KDWT BASE W/BKT W/OMSEC SCANTL.

OUTPUT FILE: 4BASE.OUT

S U M M A R Y

NEUTRAL AXIS HEIGHT = 7.36 (M) ABV. KEEL

	CALC SECTION MODULUS (CM**2-M)	PROPOSED ABS 1990 RULE CHANGES REQ. SECTION MODULUS (CM**2-M)	SM RATIO SMR/SMA
TOP	166568.10	112311.00	.674
BOTTOM	234093.30	112311.00	.480
	CALC HULL-GIRDER MOMENT OF INERTIA (CM**2-M**2)	REQ. HULL-GIRDER MOMENT OF INERTIA (CM**2-M**2)	
	1722569.00	782639.70	

**95KDWT Base Alternative Vessel 9510 Longitudinal
Scantlings with
ABS OMSEC Program**

ABS/OMSEC PROGRAM VERSION 3.02
 (BASED ON PROPOSED ABS RULE CHANGES FOR 1991)
 INP FILE: 1BASE.INP TLB FILE: TABLE2.TLB
 TITLE : 95KDWT BASE HULL W/OMSEC SCANTL. 9510

OUTPUT FILE: 1BASE.OUT

TYPE OF VESSEL: OIL CARRIER
 IBCODE : 1 ISCODE : 1 ISTRUT : 0

LBP	:	234.00	(METER)				
L(SCANT.)	:	231.54	(METER)	BILGE RADIUS	:	1.90	(METER)
BREADTH	:	42.00	(METER)	D. B. HEIGHT	:	2.20	(METER)
DEPTH	:	19.50	(METER)	DEADRISE	:	.00	(METER)
DRAFT	:	13.60	(METER)	CAMBER	:	.80	(METER)
WIDTH SHEER:		2.90	(METER)	GUNWALE RADIUS:		.00	(METER)
WIDTH_KEEL :		2.43	(METER)	WIDTH_FLATDECK:		6.60	(METER)
ZDIST :		5.00	(METER)	WIDTH_FLATBOT.:		.00	(METER)
WIDTH_STRNG:		2.50	(METER)				

DISPLACEMENT : 108450. (METRIC TONS)
 BLOCK COEFFICIENT : .800

ASSIGNED		EXTENT OF MATERIAL		YIELD STRESS KG/MM2	ULTIMATE STRESS KG/MM2	Q-FACTOR (6.13.3)
MATERIAL NUMBER	DESC	BOTTOM (METER)	TOP (METER)			
2	AH32	.00	1.90	32.	48.	.780
1	MILD	1.90	16.60	24.	41.	1.000
2	AH32	16.60	20.40	32.	48.	.780

NOMINAL WEB SPACING = 3.58 (METER)
 FLOOR OR SUPPORTING SPACING = 3.58 (METER)

S E C T I O N M O D U L U S

(BASED ON PROPOSED ABS RULE CHANGES FOR 1991)

LENGTH OF VESSEL : 231.54 (METER)
 BREADTH OF VESSEL : 42.00 (METER)
 BLOCK COEFFICIENT : .800

C1 : .102E+02
 C2 : .100E-01

STILL WATER BM (Msw) = 242301.80 (TONS-METERS)
 ABS Wave Sagging BM (Mws) = -385909.10 (TONS-METERS)
 ABS Wave Hogging BM (Mwh) = 355320.70 (TONS-METERS)

BENDING MOMENT (FOR THE DESIGN) = 597622.50 (TONS-METERS)

(6.3.4 A SECTION MODULUS)

FP = 1.784 (MT/CM**2)
 SM = 334990.20 (CM**2-M)

(6.3.4 2. MINIMUM SECTION MODULUS)

C1 = .10184E+02
 SM = 343947.50 (CM**2-M)

(BENDING STRESS AND REQUIRED SECTION MODULUS)

SIGMA B = 1.738 (MT/CM**2)
 SM = 343947.50 (CM**2-M)

(6.3.4 B REQUIRED HULL-GIRDER MOMENT OF INERTIA)

HGMI = 2391520.00 (CM**2-M**2)

(VALUES MODIFIED BY Q FACTOR)

	REQ. SECTION MODULUS (CM**2-M)	Q-FACTOR	LIMIT STRESS (MT/CM**2)
TOP	268279.00	.780	2.228
BOTTOM	268279.00	.780	2.228

PLATE SEAM COORDINATES

SHELL SECTION	DESCRIPTION	NODE	GIRTHS (METER)	Y-COORD (METER)	Z-COORD (METER)
1	BOTTOM	1	.00	.00	.00
1	BOTTOM	2	2.43	2.43	.00
1	BOTTOM	3	8.00	8.00	.00
1	BOTTOM	4	16.00	16.00	.00
1	BOTTOM	5	19.10	19.10	.00
1	BOTTOM	6	22.08	21.00	1.90
2	SIDE	1	.00	21.00	1.90
2	SIDE	2	4.20	21.00	6.10
2	SIDE	3	12.78	21.00	14.68
2	SIDE	4	14.70	21.00	16.60
2	SIDE	5	17.60	21.00	19.50
3	MAIN DECK	1	.00	21.00	19.50
3	MAIN DECK	2	2.50	18.50	19.64
3	MAIN DECK	3	2.70	18.30	19.65
3	MAIN DECK	4	14.42	6.60	20.30
3	MAIN DECK	5	21.02	.00	20.30
4	INNER BOTTOM	1	.00	.00	2.20
4	INNER BOTTOM	2	8.00	8.00	2.20
4	INNER BOTTOM	3	16.00	16.00	2.20
5	BULKHEAD	1	.00	16.00	2.20
5	BULKHEAD	2	2.44	17.25	4.30
5	BULKHEAD	3	4.53	18.30	6.10
5	BULKHEAD	4	7.88	18.30	9.45
5	BULKHEAD	5	10.38	18.30	11.95
5	BULKHEAD	6	12.94	18.30	14.51
5	BULKHEAD	7	15.63	18.30	17.20
5	BULKHEAD	8	18.08	18.30	19.65
6	BULKHEAD	1	.00	.00	2.20
6	BULKHEAD	2	3.00	.00	5.20
6	BULKHEAD	3	6.00	.00	8.20
6	BULKHEAD	4	9.00	.00	11.20
6	BULKHEAD	5	12.00	.00	14.20
6	BULKHEAD	6	15.00	.00	17.20
6	BULKHEAD	7	18.10	.00	20.30

PLATE AREA, MOMENT, AND INERTIA /UNIT THICKNESS

SHELL					
SECTION	DESCRIPTION	PLATE	AREA (METER)	MOMENT (M**2)	INERTIA (M**3)
1	BOTTOM	1	2.43	.00	.0
1	BOTTOM	2	5.57	.00	.0
1	BOTTOM	3	8.00	.00	.0
1	BOTTOM	4	3.10	.00	.0
1	BOTTOM	5	2.98	2.06	2.4
2	SIDE	1	4.20	16.80	73.4
2	SIDE	2	8.58	89.15	978.9
2	SIDE	3	1.92	30.03	470.2
2	SIDE	4	2.90	52.34	946.9
3	MAIN DECK	1	2.50	48.92	957.4
3	MAIN DECK	2	.20	4.01	78.8
3	MAIN DECK	3	11.72	234.07	4675.9
3	MAIN DECK	4	6.60	133.98	2719.8
4	INNER BOTTOM	1	8.00	17.60	38.7
4	INNER BOTTOM	2	8.00	17.60	38.7
5	BULKHEAD	1	2.44	7.94	26.7
5	BULKHEAD	2	2.08	10.84	56.9
5	BULKHEAD	3	3.35	26.05	205.6
5	BULKHEAD	4	2.50	26.75	287.5
5	BULKHEAD	5	2.56	33.87	449.5
5	BULKHEAD	6	2.69	42.65	677.8
5	BULKHEAD	7	2.45	45.14	833.0
6	BULKHEAD	1	1.50	5.55	21.7
6	BULKHEAD	2	1.50	10.05	68.5
6	BULKHEAD	3	1.50	14.55	142.3
6	BULKHEAD	4	1.50	19.05	243.1
6	BULKHEAD	5	1.50	23.55	370.9
6	BULKHEAD	6	1.55	29.06	546.2

ABS/OMSEC PROGRAM VERSION 3.02
(BASED ON PROPOSED ABS RULE CHANGES FOR 1991)
INP FILE: 1BASE.INP TLB FILE: TABLE2.TLB
TITLE : 95KDWT BASE HULL W/OMSEC SCANTL.

PAGE - 5

OUTPUT FILE: 1BASE.OUT

BOTTOM GIRDERS -

ITEM	X-ORD.	Y-ORD.	WEB H	WEB T	FACE W	FACE T	AREA	ARM	XI0
1	.00	.00	2200.	14.	0.	0.	30800.	1.10	12423.
2	8.00	.00	2200.	14.	0.	0.	61600.	1.10	24845.
3	16.00	.00	2200.	13.	0.	0.	55000.	1.10	22183.

SIDE STRINGERS -

ITEM	X-ORD.	Y-ORD.	PLT L	PLT T	AREA	ARM	XI0
1	21.00	6.10	2700.	14.	72900.	6.10	0.
2	21.00	14.68	2700.	14.	72900.	14.68	0.

LONGITUDIAL PLATE - 0.4L AMIDSHIPS

SHELL SECTION	ELE.	MAT'L	PLATE KG/M2	THICKNESS (MM)		LENGTH (METER)	FRAMED
				DESIGN	LOCAL RULE (REQ'D)		
KEEL PLATE	1	AH32	129.52	16.500	(16.500)	2.43	LONGITUDINAL
BOTTOM	2	AH32	117.75	15.000	(15.000)	5.57	LONGITUDINAL
BOTTOM	3	AH32	117.75	15.000	(15.000)	8.00	LONGITUDINAL
BOTTOM	4	AH32	117.75	15.000	(15.000)	3.10	LONGITUDINAL
BOTTOM	5	AH32	117.75	15.000	(15.000)	2.98	LONGITUDINAL
SIDE	1	MILD	137.38	17.500	(17.500)	4.20	LONGITUDINAL
SIDE	2	MILD	137.38	17.500	(17.500)	8.58	LONGITUDINAL
SIDE	3	MILD	137.38	17.500	(17.500)	1.92	LONGITUDINAL
SHEERSTRAKE	4	AH32	122.36	15.587	(15.500)	2.90	LONGITUDINAL
STRINGER	1	AH32	122.36	15.587	(15.500)	2.50	LONGITUDINAL
MAIN DECK	2	AH32	122.36	15.587	(15.500)	.20	LONGITUDINAL
MAIN DECK	3	AH32	122.36	15.587	(15.500)	11.72	LONGITUDINAL
MAIN DECK	4	AH32	122.36	15.587	(15.500)	6.60	LONGITUDINAL
INNER BOTTOM	1	MILD	125.60	16.000	(16.000)	8.00	LONGITUDINAL
INNER BOTTOM	2	MILD	125.60	16.000	(16.000)	8.00	LONGITUDINAL
BULKHEAD	1	MILD	121.67	15.500	(15.500)	2.44	LONGITUDINAL
BULKHEAD	2	MILD	117.75	15.000	(15.000)	2.08	LONGITUDINAL
BULKHEAD	3	MILD	109.90	14.000	(14.000)	3.35	LONGITUDINAL
BULKHEAD	4	MILD	102.05	13.000	(13.000)	2.50	LONGITUDINAL
BULKHEAD	5	MILD	90.28	11.500	(11.500)	2.56	LONGITUDINAL
BULKHEAD	6	AH32	98.13	12.500	(12.500)	2.69	LONGITUDINAL
BULKHEAD	7	AH32	125.60	16.000	(16.000)	2.45	LONGITUDINAL
BULKHEAD	1	MILD	121.67	15.500	(15.500)	3.00	LONGITUDINAL
BULKHEAD	2	MILD	113.82	14.500	(14.500)	3.00	LONGITUDINAL
BULKHEAD	3	MILD	105.97	13.500	(13.500)	3.00	LONGITUDINAL
BULKHEAD	4	MILD	94.20	12.000	(12.000)	3.00	LONGITUDINAL
BULKHEAD	5	AH32	98.13	12.500	(12.500)	3.00	LONGITUDINAL
BULKHEAD	6	AH32	125.60	16.000	(16.000)	3.10	LONGITUDINAL

(BASED ON PROPOSED ABS RULE CHANGES FOR 1991)

INP FILE: 1BASE.INP

TLB FILE: TABLE2.TLB

OUTPUT FILE: 1BASE.OUT

TITLE : 95KDWT BASE HULL W/OMSEC SCANTL.

LONGITUDINAL STIFFENER SCANTLINGS - 0.4L AMIDSHIPS

SECTION NO. = 1 (BOTTOM) NOMINAL SPACING = .800

NO	MAT'L	SCANTLINGS	AREA	PLATE THK	PLATE EFW	Y-ORD.	Z-ORD.	RULE SM (ABS)	CALC. SM
1	AH32	400X100X13X18	7000.	16.5	800.	.80	.00	1168.	1318.
2	AH32	400X100X13X18	7000.	16.5	800.	1.60	.00	1168.	1318.
3	AH32	400X100X13X18	7000.	16.5	800.	2.40	.00	1168.	1318.
4	AH32	400X100X13X18	7000.	15.0	800.	3.20	.00	1168.	1305.
5	AH32	400X100X13X18	7000.	15.0	800.	4.00	.00	1168.	1305.
6	AH32	400X100X13X18	7000.	15.0	800.	4.80	.00	1168.	1305.
7	AH32	400X100X13X18	7000.	15.0	800.	5.60	.00	1168.	1305.
8	AH32	400X100X13X18	7000.	15.0	800.	6.40	.00	1168.	1305.
9	AH32	400X100X13X18	7000.	15.0	800.	7.20	.00	1168.	1305.
10	AH32	400X100X13X18	7000.	15.0	800.	8.80	.00	1168.	1305.
11	AH32	400X100X13X18	7000.	15.0	800.	9.60	.00	1168.	1305.
12	AH32	400X100X13X18	7000.	15.0	800.	10.40	.00	1168.	1305.
13	AH32	400X100X13X18	7000.	15.0	800.	11.20	.00	1168.	1305.
14	AH32	400X100X13X18	7000.	15.0	800.	12.00	.00	1168.	1305.
15	AH32	400X100X13X18	7000.	15.0	800.	12.80	.00	1168.	1305.
16	AH32	400X100X13X18	7000.	15.0	800.	13.60	.00	1168.	1305.
17	AH32	400X100X13X18	7000.	15.0	800.	14.40	.00	1168.	1305.
18	AH32	400X100X13X18	7000.	15.0	800.	15.20	.00	1168.	1305.
19	AH32	400X100X13X18	7000.	15.0	800.	16.80	.00	1168.	1305.
20	AH32	400X100X13X18	7000.	15.0	800.	17.60	.00	1168.	1305.
21	AH32	400X100X13X18	7000.	15.0	800.	18.40	.00	1168.	1305.
22	AH32	400X100X13X18	7000.	15.0	800.	19.10	.00	1168.	1305.

LONGITUDINAL STIFFENER SCANTLINGS - 0.4L AMIDSHIPS

SECTION NO. = 2 (SIDE) NOMINAL SPACING = .780

NO	MAT'L	SCANTLINGS	AREA	PLATE THK	PLATE EFW	Y-ORD.	Z-ORD.	RULE SM (ABS)	CALC. SM
1	AH32	400X100X13X18	7000.	17.5	780.	21.00	1.90	1035.	1323.
2	MILD	400X100X13X18	7000.	17.5	780.	21.00	2.68	1272.	1323.
3	MILD	400X100X13X18	7000.	17.5	780.	21.00	3.46	1217.	1323.
4	MILD	400X100X13X18	7000.	17.5	780.	21.00	4.24	1162.	1323.
5	MILD	400X100X13X18	7000.	17.5	780.	21.00	5.02	1107.	1323.
6	MILD	350X100X12X17	5900.	17.5	780.	21.00	6.88	977.	1034.
7	MILD	350X100X12X17	5900.	17.5	780.	21.00	7.66	922.	1034.
8	MILD	350X100X12X17	5900.	17.5	780.	21.00	8.44	867.	1034.
9	MILD	350X100X12X17	5900.	17.5	780.	21.00	9.22	813.	1034.
10	MILD	350X100X12X17	5900.	17.5	780.	21.00	10.00	758.	1034.
11	MILD	300X90X11X16	4740.	17.5	780.	21.00	10.78	703.	739.
12	MILD	300X90X11X16	4740.	17.5	780.	21.00	11.56	648.	739.
13	MILD	300X90X11X16	4740.	17.5	780.	21.00	12.34	594.	739.
14	MILD	250X90X10X15	3850.	17.5	780.	21.00	13.12	539.	540.
15	MILD	250X90X10X15	3850.	17.5	780.	21.00	13.90	484.	540.
16	MILD	250X90X10X15	3850.	17.5	780.	21.00	15.46	375.	540.
17	MILD	250X90X10X15	3850.	17.5	780.	21.00	16.24	320.	540.
18	AH32	250X90X10X15	3850.	15.6	780.	21.00	17.02	207.	534.
19	AH32	250X90X10X15	3850.	15.6	780.	21.00	17.80	164.	534.
20	AH32	250X90X10X15	3850.	15.6	780.	21.00	18.58	122.	534.

(BASED ON PROPOSED ABS RULE CHANGES FOR 1991)

INP FILE: 1BASE.INP

TLB FILE: TABLE2.TLB

OUTPUT FILE: 1BASE.OUT

TITLE : 95KDWT BASE HULL W/OMSEC SCANTL.

LONGITUDINAL STIFFENER SCANTLINGS - 0.4L AMIDSHIPS

SECTION NO. = 3 (MAIN DECK) NOMINAL SPACING = .800

NO	MAT'L	SCANTLINGS	AREA	PLATE THK	PLATE EFW	Y-ORD.	Z-ORD.	RULE SM (ABS)	CALC. SM
1	AH32	300X18	5400.	15.6	800.	20.20	19.54	190.	517.
2	AH32	300X18	5400.	15.6	800.	19.40	19.59	190.	517.
3	AH32	300X18	5400.	15.6	800.	18.60	19.63	190.	517.
4	AH32	300X18	5400.	15.6	800.	17.50	19.69	190.	517.
5	AH32	300X18	5400.	15.6	800.	16.70	19.74	190.	517.
6	AH32	300X18	5400.	15.6	800.	15.90	19.78	190.	517.
7	AH32	300X18	5400.	15.6	800.	15.10	19.83	190.	517.
8	AH32	300X18	5400.	15.6	800.	14.31	19.87	190.	517.
9	AH32	300X18	5400.	15.6	800.	13.51	19.92	190.	517.
10	AH32	300X18	5400.	15.6	800.	12.71	19.96	190.	517.
11	AH32	300X18	5400.	15.6	800.	11.91	20.01	190.	517.
12	AH32	300X18	5400.	15.6	800.	11.11	20.05	190.	517.
13	AH32	300X18	5400.	15.6	800.	10.31	20.09	190.	517.
14	AH32	300X18	5400.	15.6	800.	9.51	20.14	190.	517.
15	AH32	300X18	5400.	15.6	800.	8.71	20.18	190.	517.
16	AH32	300X18	5400.	15.6	800.	7.92	20.23	190.	517.
17	AH32	300X18	5400.	15.6	800.	7.12	20.27	190.	517.
18	AH32	300X18	5400.	15.6	800.	6.32	20.30	190.	517.
19	AH32	300X18	5400.	15.6	800.	5.52	20.30	190.	517.
20	AH32	300X18	5400.	15.6	800.	4.72	20.30	190.	517.
21	AH32	300X18	5400.	15.6	800.	3.92	20.30	190.	517.
22	AH32	300X18	5400.	15.6	800.	3.12	20.30	190.	517.
23	AH32	300X18	5400.	15.6	800.	2.32	20.30	190.	517.
24	AH32	300X18	5400.	15.6	800.	1.52	20.30	190.	517.
25	AH32	300X18	5400.	15.6	800.	.72	20.30	190.	517.

(BASED ON PROPOSED ABS RULE CHANGES FOR 1991)

INP FILE: 1BASE.INP

TLB FILE: TABLE2.TLB

OUTPUT FILE: 1BASE.OUT

TITLE : 95KDWT BASE HULL W/OMSEC SCANTL.

LONGITUDINAL STIFFENER SCANTLINGS - 0.4L AMIDSHIPS

SECTION NO. = 4 (INNER BOTTOM) NOMINAL SPACING = .800

NO	MAT'L	SCANTLINGS	AREA	PLATE THK	PLATE EFW	Y-ORD.	Z-ORD.	RULE SM (ABS)	CALC. SM
1	MILD	450X150X11.5X15	7425.	16.0	800.	.80	2.20	1579.	1673.
2	MILD	450X150X11.5X15	7425.	16.0	800.	1.60	2.20	1579.	1673.
3	MILD	450X150X11.5X15	7425.	16.0	800.	2.40	2.20	1579.	1673.
4	MILD	450X150X11.5X15	7425.	16.0	800.	3.20	2.20	1579.	1673.
5	MILD	450X150X11.5X15	7425.	16.0	800.	4.00	2.20	1579.	1673.
6	MILD	450X150X11.5X15	7425.	16.0	800.	4.80	2.20	1579.	1673.
7	MILD	450X150X11.5X15	7425.	16.0	800.	5.60	2.20	1579.	1673.
8	MILD	450X150X11.5X15	7425.	16.0	800.	6.40	2.20	1579.	1673.
9	MILD	450X150X11.5X15	7425.	16.0	800.	7.20	2.20	1579.	1673.
10	MILD	450X150X11.5X15	7425.	16.0	800.	8.80	2.20	1579.	1673.
11	MILD	450X150X11.5X15	7425.	16.0	800.	9.60	2.20	1579.	1673.
12	MILD	450X150X11.5X15	7425.	16.0	800.	10.40	2.20	1579.	1673.
13	MILD	450X150X11.5X15	7425.	16.0	800.	11.20	2.20	1579.	1673.
14	MILD	450X150X11.5X15	7425.	16.0	800.	12.00	2.20	1579.	1673.
15	MILD	450X150X11.5X15	7425.	16.0	800.	12.80	2.20	1579.	1673.
16	MILD	450X150X11.5X15	7425.	16.0	800.	13.60	2.20	1579.	1673.
17	MILD	450X150X11.5X15	7425.	16.0	800.	14.40	2.20	1579.	1673.
18	MILD	450X150X11.5X15	7425.	16.0	800.	15.20	2.20	1579.	1673.

(BASED ON PROPOSED ABS RULE CHANGES FOR 1991)

INP FILE: 1BASE.INP

TLB FILE: TABLE2.TLB

OUTPUT FILE: 1BASE.OUT

TITLE : 95KDWT BASE HULL W/OMSEC SCANTL.

LONGITUDINAL STIFFENER SCANTLINGS - 0.4L AMIDSHIPS

SECTION NO. = 5 (BULKHEAD) NOMINAL SPACING = .780

NO	MAT'L	SCANTLINGS	AREA	PLATE THK	PLATE EFW	Y-ORD.	Z-ORD.	RULE SM (ABS)	CALC. SM
1	MILD	450X150X11.5X15	7425.	15.5	780.	16.38	2.84	1340.	1666.
2	MILD	400X100X13X18	7000.	15.5	780.	16.77	3.49	1295.	1307.
3	MILD	400X100X13X18	7000.	15.5	780.	17.15	4.13	1250.	1307.
4	MILD	400X100X13X18	7000.	15.0	780.	17.55	4.82	1202.	1303.
5	MILD	400X100X13X18	7000.	15.0	780.	17.93	5.47	1156.	1303.
6	MILD	400X100X13X18	7000.	14.0	780.	18.30	6.85	1059.	1293.
7	MILD	350X100X12X17	5900.	14.0	780.	18.30	7.63	1004.	1012.
8	MILD	350X100X12X17	5900.	14.0	780.	18.30	8.41	950.	1012.
9	MILD	350X100X12X17	5900.	14.0	780.	18.30	9.19	895.	1012.
10	MILD	350X100X12X17	5900.	13.0	780.	18.30	10.05	834.	1005.
11	MILD	350X100X12X17	5900.	13.0	780.	18.30	10.83	780.	1005.
12	MILD	350X100X12X17	5900.	13.0	780.	18.30	11.61	725.	1005.
13	MILD	300X90X11X16	4740.	13.0	780.	18.30	12.39	670.	719.
14	MILD	300X90X11X16	4740.	11.5	780.	18.30	12.35	673.	711.
15	MILD	300X90X11X16	4740.	11.5	780.	18.30	13.13	618.	711.
16	MILD	300X90X11X16	4740.	11.5	780.	18.30	13.91	564.	711.
17	MILD	250X90X10X15	3850.	12.5	780.	18.30	15.50	452.	524.
18	MILD	250X90X10X15	3850.	12.5	780.	18.30	16.28	397.	524.
19	AH32	250X90X10X15	3850.	12.5	780.	18.30	17.06	267.	524.
20	AH32	250X90X10X15	3850.	16.0	780.	18.30	17.85	224.	535.
21	AH32	250X90X10X15	3850.	16.0	780.	18.30	18.63	181.	535.
22	AH32	250X90X10X15	3850.	16.0	780.	18.30	19.41	138.	535.

LONGITUDINAL STIFFENER SCANTLINGS - 0.4L AMIDSHIPS

SECTION NO. = 6 (BULKHEAD) NOMINAL SPACING = .780

NO	MAT'L	SCANTLINGS	AREA	PLATE THK	PLATE EFW	Y-ORD.	Z-ORD.	RULE SM (ABS)	CALC. SM
1	MILD	450X150X11.5X15	7425.	15.5	780.	.00	2.98	1331.	1666.
2	MILD	400X100X13X18	7000.	15.5	780.	.00	3.76	1276.	1307.
3	MILD	400X100X13X18	7000.	15.5	780.	.00	4.54	1221.	1307.
4	MILD	400X100X13X18	7000.	14.5	780.	.00	5.32	1166.	1298.
5	MILD	400X100X13X18	7000.	14.5	780.	.00	6.10	1112.	1298.
6	MILD	400X100X13X18	7000.	14.5	780.	.00	6.88	1057.	1298.
7	MILD	350X100X12X17	5900.	14.5	780.	.00	7.66	1002.	1016.
8	MILD	350X100X12X17	5900.	13.5	780.	.00	8.44	947.	1009.
9	MILD	350X100X12X17	5900.	13.5	780.	.00	9.22	893.	1009.
10	MILD	350X100X12X17	5900.	13.5	780.	.00	10.00	838.	1009.
11	MILD	350X100X12X17	5900.	13.5	780.	.00	10.78	783.	1009.
12	MILD	350X100X12X17	5900.	12.0	780.	.00	11.56	728.	997.
13	MILD	300X90X11X16	4740.	12.0	780.	.00	12.34	674.	714.
14	MILD	300X90X11X16	4740.	12.0	780.	.00	13.12	619.	714.
15	MILD	300X90X11X16	4740.	12.0	780.	.00	13.90	564.	714.
16	MILD	250X90X10X15	3850.	12.5	780.	.00	14.68	509.	524.
17	MILD	250X90X10X15	3850.	12.5	780.	.00	15.46	455.	524.
18	MILD	250X90X10X15	3850.	12.5	780.	.00	16.24	400.	524.
19	AH32	250X90X10X15	3850.	12.5	780.	.00	17.02	269.	524.
20	AH32	250X90X10X15	3850.	16.0	780.	.00	17.80	227.	535.
21	AH32	250X90X10X15	3850.	16.0	780.	.00	18.58	184.	535.
22	AH32	250X90X10X15	3850.	16.0	780.	.00	19.36	141.	535.

(BASED ON PROPOSED ABS RULE CHANGES FOR 1991)

INP FILE: 1BASE.INP

TLB FILE: TABLE2.TLB

OUTPUT FILE: 1BASE.OUT

TITLE : 95KDWT BASE HULL W/OMSEC SCANTL.

SUMMARY OF LONGITUDINAL MATERIAL - 0.4L AMIDSHIPS

SECTION	DESCRIPTION	P L A T E		LONGITUDINAL		SECTION	
		AREA (MM-M)	(MT/M)	AREA (MM-M)	(MT/M)	(MT/M)	
1	BOTTOM	334.92	2.63	154.00	1.21	3.84	
2	SIDE	302.45	2.37	105.67	.83	3.20	
3	MAIN DECK	327.68	2.57	135.00	1.06	3.63	
4	INNER BOTTOM	256.00	2.01	133.65	1.05	3.06	
5	BULKHEAD	250.80	1.97	119.89	.94	2.91	
6	BULKHEAD	126.80	1.00	59.50	.47	1.46	
SUB-TOTAL---		1598.65	12.55	707.70	5.56	18.10	
						DECK GIRDERS	.00
						BOTTOM GIRDERS	.58
						SIDE STRINGERS	.57
						MISC. VERT. PLTS	.00
						(ONE SIDE) TOTAL	19.26
						TOTAL	38.51

TOTAL WEIGHT OF LONG'L MATERIAL - 0.4L AMIDSHIPS

0.4L AMIDSHIPS = 92.62 (M)
 STEEL WEIGHT = 3566.76 (MT)

S U M M A R Y

NEUTRAL AXIS HEIGHT = 8.59 (M) ABV. KEEL

	CALC SECTION MODULUS (CM**2-M)	PROPOSED ABS 1990 RULE CHANGES REQ. SECTION MODULUS (CM**2-M)	SM RATIO SMR/SMA
TOP	267620.80	268279.00	1.002
BOTTOM	339548.60	268279.00	.790
	CALC HULL-GIRDER MOMENT OF INERTIA (CM**2-M**2)	REQ. HULL-GIRDER MOMENT OF INERTIA (CM**2-M**2)	
	2918411.00	2391520.00	

**40KDWT Base Alternative Vessel 4010
Break Down of Blocks and Piece Parts**

Alternative 4010

WEIGHTS AND WELD LENGTH FOR ONE TANK ELEMENTS OF BLOCKS

Block	Elem of Block	Comments	Uniq. Item #	Total # Elem of Block	L (ft)	F.B. (ft)	Angle (deg)	Top (ft)	Bottom (ft)	Bulb (ft)	L (ft)	Area of Bulb (sq ft)	Area of Plate (sq ft)	Weight (MT)	Welding Flat Plate		Welding Curved Plate		Manual	Blot	
															Automatic	Blot	Automatic	Blot			
Bottom Block	1	Center-line	1	1	10.74	16.00	1	1	1	1	1	1	1	1	1	1	1	1	1	1	1
2 Bottom Pt	1		1	1	10.74	16.00	1	1	1	1	1	1	1	1	1	1	1	1	1	1	1
3 Bottom Pt	2		1	2	10.74	14.50	1	1	1	1	1	1	1	1	1	1	1	1	1	1	1
1 D.B. Pt	3		1	3	10.74	14.50	1	1	1	1	1	1	1	1	1	1	1	1	1	1	1
Floors	4		1	4	3.20	15.50	1	1	1	1	1	1	1	1	1	1	1	1	1	1	1
Bottom Long	1		1	1	2.20	19.50	1	1	1	1	1	1	1	1	1	1	1	1	1	1	1
O.S. Long	1		1	1	10.74	14.50	1	1	1	1	1	1	1	1	1	1	1	1	1	1	1
Girders	1		1	1	10.74	14.00	1	1	1	1	1	1	1	1	1	1	1	1	1	1	1
Girders	1		1	1	2.20	14.00	1	1	1	1	1	1	1	1	1	1	1	1	1	1	1
Floor Stiffeners	30		1	30	2.20	12.00	1	1	1	1	1	1	1	1	1	1	1	1	1	1	1
1-2 Joints	60		1	60	0.20	12.00	1	1	1	1	1	1	1	1	1	1	1	1	1	1	1
Total Area of Curved Plate =														866.99	Total Area of Curved Plate =		866.99				
Total Area of Flat Plate =														172.6	Total Area of Flat Plate =		172.6				
Total Weight =														657.7	Total Weight =		657.7				

**95KDWT Base Alternative Vessel 9510
Break Down of Blocks and Piece Parts**

Alternative: 9510

WEIGHTS AND WELD VOLUME FOR ONE TANK ELEMENTS OF BLOCKS

Elements of Hopper Block	S/C	Part	Comments	Unique Item #	Ea	L	F	B	A	T	B	L	A	A	W	Welding Flat Pits		Welding Curved Plate		
																Automatic	Manual	Automatic	Manual	
				1	2	3	4	5	6	7	8	9	10	11	12	13	14	15	16	
Hopper Block	4-1	Part																		
1 Side Pit	5-1	Starboard		1	2	1	1	1	1	1	1	1	1	1	1	1	1	1	1	1
2 Side Pit				2	2	1	1	1	1	1	1	1	1	1	1	1	1	1	1	1
1 Hopper Pit				2	2	1	1	1	1	1	1	1	1	1	1	1	1	1	1	1
2 Hopper Pit				2	2	1	1	1	1	1	1	1	1	1	1	1	1	1	1	1
Shimner Pit				2	2	1	1	1	1	1	1	1	1	1	1	1	1	1	1	1
Sub Web Pit				2	2	1	1	1	1	1	1	1	1	1	1	1	1	1	1	1
Side Web Flg				2	2	1	1	1	1	1	1	1	1	1	1	1	1	1	1	1
Hopper Side Web				2	2	1	1	1	1	1	1	1	1	1	1	1	1	1	1	1
Hopper Sub Flg				2	2	1	1	1	1	1	1	1	1	1	1	1	1	1	1	1
Upper Bkt				2	2	1	1	1	1	1	1	1	1	1	1	1	1	1	1	1
Upper Bkt Flg				2	2	1	1	1	1	1	1	1	1	1	1	1	1	1	1	1
Lower Bkt Web				2	2	1	1	1	1	1	1	1	1	1	1	1	1	1	1	1
Lower Bkt Flg				2	2	1	1	1	1	1	1	1	1	1	1	1	1	1	1	1
Plate two Tank Bhd				2	2	1	1	1	1	1	1	1	1	1	1	1	1	1	1	1
Sub Longi				2	2	1	1	1	1	1	1	1	1	1	1	1	1	1	1	1
Hopper Longi				2	2	1	1	1	1	1	1	1	1	1	1	1	1	1	1	1
Hopper Longi				2	2	1	1	1	1	1	1	1	1	1	1	1	1	1	1	1
Tank Bhd Longi				2	2	1	1	1	1	1	1	1	1	1	1	1	1	1	1	1
Tank Bhd Longi				2	2	1	1	1	1	1	1	1	1	1	1	1	1	1	1	1
Tank Bhd Longi				2	2	1	1	1	1	1	1	1	1	1	1	1	1	1	1	1
Web Stiffeners				2	2	1	1	1	1	1	1	1	1	1	1	1	1	1	1	1
Totals	18	164		96	213															

Alternative: 9510

WEIGHTS AND WELD VOLUME FOR ONE TANK

ELEMENTS OF BLOCKS

Element of Block	Qty	Part	Comments	Diameter of Item	Total # Elements	F.B. Length (m)	L (m)	U (m)	Bulb Top (m)	Bulb Bottom (m)	Length (m)	Area of Bulb (m²)	Area of Plate (m²)	Weight (kg)	Welding Part Plate		Welding Coupled Plate	
															Automatic	Manual	Automatic	Manual
6-1 Side Plate	1	Starboard		1	2	10.74	17.50	11.11	1.11	1.11	1.11	1.11	1.11	1.11	1.11	1.11	1.11	1.11
7-1 Side Plate	1	Starboard		1	2	10.74	17.50	11.11	1.11	1.11	1.11	1.11	1.11	1.11	1.11	1.11	1.11	1.11
2 Star Plate	2			2	2	2.95	17.50	63.37	8.71	1.11	1.11	1.11	1.11	1.11	1.11	1.11	1.11	1.11
3 Star Plate	2			2	2	10.74	17.50											
4 Star Plate	2			2	2	10.74	17.50											
5 Star Plate	2			2	2	10.74	17.50											
6 Star Plate	2			2	2	10.74	17.50											
Deck Plate	1			1	2	2.43	15.50											
1 Hopper Side	1			1	2	2.85	15.50											
2 Hopper Side	1			1	2	3.00	14.00											
3 Hopper Side	1			1	2	10.74	11.50											
4 Hopper Side	1			1	2	10.74	11.50											
5 Hopper Side	1			1	2	10.74	11.50											
Webb Lower	1			1	6	3.00	16.00											
Webb Mid	1			1	6	2.70	15.00											
Webb Upper	1			1	6	2.70	15.00											
Upper Backset	1			1	6	4.50	20.00											
Upper Bk Flange	1			1	6	4.50	20.00											
Side Longitudinal	1			1	10	10.74	50.00											
Star Longitudinal	1			1	6	0.45	14.50											
Star Longitudinal	1			1	6	0.45	14.50											
Lg Bhd Long	1			1	12	10.74	47.00											
Lg Bhd Long	1			1	12	10.74	47.00											
Lg Bhd Long	1			1	14	10.74	50.00											
Mn Dk Long	1			1	4	0.34	12.50											
Stringer	2			2	2	10.74	13.50											
Webb Silencers	1			1	136	2.20	12.00											
Totals	19	252		342	644	1156.10	1156.61											
Total Area of Coupled Plate =														1156.10				
Total Area of Coupled Plate =														1156.10				
Total Weight =														2890.0 W				

Alternative: 9510

WEIGHTS AND WELD VOLUME FOR ONE TANK
ELEMENTS OF BLOCKS

Element of	BLK	Comments	Uniqal Item	Total # of Ea	L	L	L	L	L	L	L	L	L	L	L	L	L	L	L	L	L	L	Welding Flat Plate			Welding Curved Plate																							
																							Material	Material	Material	Material	Material	Material	Material	Material	Material	Material	Material	Material	Material														
1 Deck	2 Deck	3 Deck	4 Deck	5 Deck	Web	Web Flange	Deck Longitudinal	Web Stiffeners	9-1	9-2	9-1	9-2	9-1	9-2	9-1	9-2	9-1	9-2	9-1	9-2	9-1	9-2	9-1	9-2	9-1	9-2	9-1	9-2																					
Deck Black	1	Deck	1	2	2	10.74	15.50	3.00	15.50	1.1	1.1	1.1	1.1	1.1	1.1	1.1	1.1	1.1	1.1	1.1	1.1	1.1	1.1	1.1	1.1	1.1	1.1	1.1																					
Deck Plate	1	Straight	1	2	2	10.74	15.50	3.00	15.50	1.1	1.1	1.1	1.1	1.1	1.1	1.1	1.1	1.1	1.1	1.1	1.1	1.1	1.1	1.1	1.1	1.1	1.1	1.1																					
2 Deck Plate	2		2	2	2	10.74	15.50	3.00	15.50	1.1	1.1	1.1	1.1	1.1	1.1	1.1	1.1	1.1	1.1	1.1	1.1	1.1	1.1	1.1	1.1	1.1	1.1	1.1																					
3 Deck Plate	2		2	2	2	10.74	15.50	3.00	15.50	1.1	1.1	1.1	1.1	1.1	1.1	1.1	1.1	1.1	1.1	1.1	1.1	1.1	1.1	1.1	1.1	1.1	1.1	1.1																					
4 Deck Plate	2		2	2	2	10.74	15.50	3.00	15.50	1.1	1.1	1.1	1.1	1.1	1.1	1.1	1.1	1.1	1.1	1.1	1.1	1.1	1.1	1.1	1.1	1.1	1.1	1.1																					
5 Deck Plate	2		2	2	2	10.74	15.50	3.00	15.50	1.1	1.1	1.1	1.1	1.1	1.1	1.1	1.1	1.1	1.1	1.1	1.1	1.1	1.1	1.1	1.1	1.1	1.1	1.1																					
Web	1		1	6	6	2.96	15.50	2.96	15.50	1.1	1.1	1.1	1.1	1.1	1.1	1.1	1.1	1.1	1.1	1.1	1.1	1.1	1.1	1.1	1.1	1.1	1.1	1.1																					
Web Flange	1		1	6	6	14.95	12.50	2.40	12.50	1.1	1.1	1.1	1.1	1.1	1.1	1.1	1.1	1.1	1.1	1.1	1.1	1.1	1.1	1.1	1.1	1.1	1.1	1.1																					
Deck Longitudinal	1		1	36	36	10.74	15.50	0.25	20.00	1.1	1.1	1.1	1.1	1.1	1.1	1.1	1.1	1.1	1.1	1.1	1.1	1.1	1.1	1.1	1.1	1.1	1.1	1.1																					
Web Stiffeners	1		1	144	144	0.50	18.00	0.50	18.00	1.1	1.1	1.1	1.1	1.1	1.1	1.1	1.1	1.1	1.1	1.1	1.1	1.1	1.1	1.1	1.1	1.1	1.1	1.1																					
9-1	7		7	202	202	0.15	12.00	0.15	12.00	1.1	1.1	1.1	1.1	1.1	1.1	1.1	1.1	1.1	1.1	1.1	1.1	1.1	1.1	1.1	1.1	1.1	1.1	1.1																					
9-2																																																	
																						Total Area of Curved Plate =			673.76																								

Alternative: 9510

WEIGHTS AND WELD VOLUME FOR ONE TANK
ELEMENTS OF BLOCKS

Element of	BLK	Comments	Uniqal Item	Total # of Ea	L	L	L	L	L	L	L	L	L	L	L	L	L	L	L	L	L	L	Welding Flat Plate			Welding Curved Plate																							
																							Material	Material	Material	Material	Material	Material	Material	Material	Material	Material	Material	Material	Material														
1 Deck	2 Deck	3 Deck	4 Deck	5 Deck	Web	Web Flange	Deck Longitudinal	Web Stiffeners	9-1	9-2	9-1	9-2	9-1	9-2	9-1	9-2	9-1	9-2	9-1	9-2	9-1	9-2	9-1	9-2	9-1	9-2	9-1	9-2																					
Deck Black	1	Deck	1	2	2	14.32	15.50	3.00	15.50	1.1	1.1	1.1	1.1	1.1	1.1	1.1	1.1	1.1	1.1	1.1	1.1	1.1	1.1	1.1	1.1	1.1	1.1																						
Deck Plate	1	Straight	1	2	2	14.32	15.50	3.00	15.50	1.1	1.1	1.1	1.1	1.1	1.1	1.1	1.1	1.1	1.1	1.1	1.1	1.1	1.1	1.1	1.1	1.1	1.1																						
2 Deck Plate	2		2	2	2	14.32	15.50	3.00	15.50	1.1	1.1	1.1	1.1	1.1	1.1	1.1	1.1	1.1	1.1	1.1	1.1	1.1	1.1	1.1	1.1	1.1	1.1																						
3 Deck Plate	2		2	2	2	14.32	15.50	3.00	15.50	1.1	1.1	1.1	1.1	1.1	1.1	1.1	1.1	1.1	1.1	1.1	1.1	1.1	1.1	1.1	1.1	1.1	1.1																						
4 Deck Plate	2		2	2	2	14.32	15.50	3.00	15.50	1.1	1.1	1.1	1.1	1.1	1.1	1.1	1.1	1.1	1.1	1.1	1.1	1.1	1.1	1.1	1.1	1.1	1.1																						
5 Deck Plate	2		2	2	2	14.32	15.50	3.00	15.50	1.1	1.1	1.1	1.1	1.1	1.1	1.1	1.1	1.1	1.1	1.1	1.1	1.1	1.1	1.1	1.1	1.1	1.1																						
Web	1		1	6	6	2.96	15.50	2.96	15.50	1.1	1.1	1.1	1.1	1.1	1.1	1.1	1.1	1.1	1.1	1.1	1.1	1.1	1.1	1.1	1.1	1.1	1.1																						
Web Flange	1		1	6	6	14.95	12.50	2.40	12.50	1.1	1.1	1.1	1.1	1.1	1.1	1.1	1.1	1.1	1.1	1.1	1.1	1.1	1.1	1.1	1.1	1.1	1.1																						
Deck Longitudinal	1		1	36	36	10.74	15.50	0.25	20.00	1.1	1.1	1.1	1.1	1.1	1.1	1.1	1.1	1.1	1.1	1.1	1.1	1.1	1.1	1.1	1.1	1.1	1.1	1.1																					
Web Stiffeners	1		1	108	108	0.50	18.00	0.50	18.00	1.1	1.1	1.1	1.1	1.1	1.1	1.1	1.1	1.1	1.1	1.1	1.1	1.1	1.1	1.1	1.1	1.1	1.1	1.1																					
9-1	4		4	108	108	0.15	12.00	0.15	12.00	1.1	1.1	1.1	1.1	1.1	1.1	1.1	1.1	1.1	1.1	1.1	1.1	1.1	1.1	1.1	1.1	1.1	1.1	1.1																					
9-2																																																	
																						Total Area of Curved Plate =			822.48																								

Alternative: 9510

WEIGHTS AND WELD VOLUME FOR ONE TANK
ELEMENTS OF BLOCKS

Elements of Block	950CWT BASE B.K. Comments	Uncol Totl # Ea Item of Item	F.B (m)	L (m)	L (m)	L (m)	L (m)	L (m)	L (m)	L (m)	L (m)	L (m)	L (m)	L (m)	L (m)	L (m)	L (m)	L (m)	L (m)	L (m)	L (m)	Welding Flat Plate		Welding Curved Plate			
																						Automatic	Manual	Automatic	Manual		
Deck Block CL 1 Deck Plate	10-1 Cantefine	1																									
2 Deck Plate		1																									
Bhd Plate		1																									
Bhd Plate		1																									
Web Port Bkt		3																									
Web Stbd Bkt		3																									
Port Bkt Flange		3																									
Stbd Bkt Flange		3																									
Deck Longitudinal		8																									
Bulkhead Longs		1																									
Bulkhead Longs		6																									
Web Stiffeners		52																									
10-1 Totals		9	86	242	75	242	94	242	94	242	94	242	94	242	94	242	94	242	94	242	94	242	94	242	94		
														Total Area Flat Plate =		242.94											
														Total Area of Curved Plate =		40.20											

Alternative: 9510

WEIGHTS AND WELD VOLUME FOR ONE TANK
ELEMENTS OF BLOCKS

Elements of Block	950CWT BASE B.K. Comments	Uncol Totl # Ea Item of Item	F.B (m)	L (m)	L (m)	L (m)	L (m)	L (m)	L (m)	L (m)	L (m)	L (m)	L (m)	L (m)	L (m)	L (m)	L (m)	L (m)	L (m)	L (m)	L (m)	Welding Flat Plate		Welding Curved Plate			
																						Automatic	Manual	Automatic	Manual		
Deck Block CL 1 Deck Plate	10-2 Cantefine	1																									
2 Deck Plate		1																									
Bhd Plate		1																									
Bhd Plate		1																									
Web Port		3																									
Web Stbd		3																									
Port Web Flange		3																									
Stbd Web Flange		3																									
Deck Longitudinal		8																									
Bulkhead Longs		1																									
Bulkhead Longs		6																									
Web Stiffeners		52																									
10-2 Totals		5	70	262	100	262	100	262	100	262	100	262	100	262	100	262	100	262	100	262	100	262	100	262	100		
														Total Area Flat Plate =		262.26											
														Total Area of Curved Plate =		40.20											

Alternative: 9510

WEIGHTS AND WELD VOLUME FOR ONE TANK ELEMENTS OF NOZZLES

ELEMENTS OF NOZZLES	9510DWZ BASE N.C. Comments	Unique Item of Item	L (ft)	L (in)	L (mm)	Area of Plate (sq in)	Area of Plate (sq mm)	Length (ft)	Bolt Dia (in)	Weight (lb)	Weld (lb)	Welding Flat Plate		Welding Curved Plate		
												Automatic	Manual	Automatic	Manual	
Trans Bhd Block	12-1 Post	1	2	2	16.00	15.50	17.70	15.50	1.1	1.1	1.1	1.1	103.7	103.7	103.7	103.7
Bhd Plate		2	2	2	2.44	15.50	2.44	15.50	1.1	1.1	1.1	1.1	23.7	23.7	23.7	23.7
Bhd Plate		2	2	2	18.00	15.00	18.00	15.00	1.1	1.1	1.1	1.1	41.2	41.2	41.2	41.2
Bhd Plate		2	2	2	2.06	15.00	2.06	15.00	1.1	1.1	1.1	1.1	18.0	18.0	18.0	18.0
Bhd Plate		2	2	2	3.36	14.00	3.36	14.00	1.1	1.1	1.1	1.1	25.7	25.7	25.7	25.7
Bhd Plate		2	2	2	18.00	13.00	18.00	13.00	1.1	1.1	1.1	1.1	16.9	16.9	16.9	16.9
Bhd Plate		2	2	2	2.50	13.00	2.50	13.00	1.1	1.1	1.1	1.1	15.1	15.1	15.1	15.1
Bhd Plate		2	2	2	18.00	12.50	18.00	12.50	1.1	1.1	1.1	1.1	28.6	28.6	28.6	28.6
Bhd Plate		2	2	2	18.00	12.50	18.00	12.50	1.1	1.1	1.1	1.1	28.6	28.6	28.6	28.6
Bhd Plate		2	2	2	2.46	16.00	2.46	16.00	1.1	1.1	1.1	1.1	18.4	18.4	18.4	18.4
Lwr Horz Web		1	2	2	18.00	16.00	18.00	16.00	1.1	1.1	1.1	1.1	28.8	28.8	28.8	28.8
Lwr Horz Web Flg		1	2	2	3.00	16.00	3.00	16.00	1.1	1.1	1.1	1.1	21.7	21.7	21.7	21.7
Lwr Horz Web Bks		1	2	2	3.56	25.00	3.56	25.00	1.1	1.1	1.1	1.1	25.6	25.6	25.6	25.6
Lwr Horz Wb Bkt Flg		1	2	2	5.50	25.00	5.50	25.00	1.1	1.1	1.1	1.1	38.7	38.7	38.7	38.7
Mid Horz Web		1	2	2	18.00	12.50	18.00	12.50	1.1	1.1	1.1	1.1	13.1	13.1	13.1	13.1
Mid Horz Web Flg		1	2	2	3.56	19.00	3.56	19.00	1.1	1.1	1.1	1.1	23.9	23.9	23.9	23.9
Mid Horz Web Bks		1	2	2	0.86	19.00	0.86	19.00	1.1	1.1	1.1	1.1	18.2	18.2	18.2	18.2
Mid Horz Wb Bkt Flg		1	2	2	5.50	19.00	5.50	19.00	1.1	1.1	1.1	1.1	26.2	26.2	26.2	26.2
Upr Horz Web		1	2	2	18.00	12.50	18.00	12.50	1.1	1.1	1.1	1.1	13.1	13.1	13.1	13.1
Upr Horz Web Flg		1	2	2	3.56	19.00	3.56	19.00	1.1	1.1	1.1	1.1	23.9	23.9	23.9	23.9
Upr Horz Web Bks		1	2	2	0.40	19.00	0.40	19.00	1.1	1.1	1.1	1.1	18.2	18.2	18.2	18.2
Upr Horz Wb Bkt Flg		1	2	2	5.50	19.00	5.50	19.00	1.1	1.1	1.1	1.1	26.2	26.2	26.2	26.2
Next Stiffener	TT 10.6.1	44	44	44	6.10	840.00	6.10	840.00	1.1	1.1	1.1	1.1	134.2	134.2	134.2	134.2
Next Stiffener	6.1-10.6	44	44	44	0.85	14.75	0.85	14.75	1.1	1.1	1.1	1.1	6.7	6.7	6.7	6.7
Next Stiffener	10.6-14.69	44	44	44	4.08	660.00	4.08	660.00	1.1	1.1	1.1	1.1	98.8	98.8	98.8	98.8
Next Stiffener	14.69-16.6	44	44	44	0.50	15.00	0.50	15.00	1.1	1.1	1.1	1.1	14.5	14.5	14.5	14.5
Web Stiffeners		66	66	66	3.56	15.00	3.56	15.00	1.1	1.1	1.1	1.1	35.4	35.4	35.4	35.4
12-1 Totals		20	280	280	0.15	12.50	0.15	12.50	1.1	1.1	1.1	1.1	65.7	65.7	65.7	65.7
Total Area of Flat Plate =											1007.82					
Total Area of Curved Plate =											2693.0 M					

**Summary - 40KDWT Alternative Vessels
All Block Properties**

Alternative: 4060
Average 1 = 4.6

WEIGHTS AND WELENGTHS FOR ONE TANK
ELEMENTS OF BLOCKS

Element	BLK	Comments	Unit	QTY	Wt (lb)	Vol (cu ft)	Area (sq ft)	Perim (ft)	Wt (lb)	Vol (cu ft)	Area (sq ft)	Perim (ft)
Bottom Block	1-1	Center-Line	8	52	66	114.5	171.8	293.05	37.4	293.05	37.4	293.05
Bottom Block	1-2	Center-Line	8	50	66	171.8	293.05	37.4	293.05	37.4	293.05	37.4
Bottom Block	2-1	Port 1-Sideband	4	148	158	237.7	395.6	500.62	62.26	500.62	62.26	500.62
Bottom Block	2-2	Port 2-Sideband	4	148	158	237.7	395.6	500.62	62.26	500.62	62.26	500.62
Bottom Block	4-1	Port 1-Sideband	4	148	158	237.7	395.6	500.62	62.26	500.62	62.26	500.62
Bottom Block	4-2	Port 2-Sideband	4	148	158	237.7	395.6	500.62	62.26	500.62	62.26	500.62
Side Block	6-1	Port 1-Sideband	2	152	145.0	403.0	642.00	804.00	60.20	804.00	60.20	804.00
Side Block	6-2	Port 2-Sideband	2	152	145.0	403.0	642.00	804.00	60.20	804.00	60.20	804.00
Backband Block	8-1	Center-Line	11	93	159.9	42.96	70.00	110.00	11.7	110.00	11.7	110.00
Backband Block	8-2	Center-Line	11	93	159.9	42.96	70.00	110.00	11.7	110.00	11.7	110.00
Deck Block	10-1	Port 1-Sideband	14	252	238.2	658.7	1065.00	1332.00	102.00	1332.00	102.00	1332.00
Deck Block	10-2	Port 2-Sideband	14	252	238.2	658.7	1065.00	1332.00	102.00	1332.00	102.00	1332.00
Deck Block	12-1	Port 1-Sideband	10	180	180.0	270.0	450.00	540.00	45.00	540.00	45.00	540.00
Deck Block	12-2	Port 2-Sideband	10	180	180.0	270.0	450.00	540.00	45.00	540.00	45.00	540.00
Deck Block	14-1	Port 1-Sideband	2	152	145.0	403.0	642.00	804.00	60.20	804.00	60.20	804.00
Deck Block	14-2	Port 2-Sideband	2	152	145.0	403.0	642.00	804.00	60.20	804.00	60.20	804.00
Total												

Welding Co. 60
Manual 29.1%
Automatic 70.9%

Flex 2, Box 1 (2) >> Auto Weld 1500
Flex 2, Box 1 (2) >> Manual Weld 1016
Flex 2, Box 1 (2) >> Manual Weld 7625
Flex 2, Box 1 (2) >> Manual Weld 2350
Flex 2, Box 1 (2) >> Manual Weld 8336
Flex 2, Box 1 (2) >> Manual Weld 1072
Flex 2, Box 1 (2) >> Manual Weld 2284
Flex 2, Box 1 (2) >> Manual Weld 2006
Flex 2, Box 1 (2) >> Manual Weld 1189

Alternative: 4070
Average 1 = 15.7

WEIGHTS AND WELENGTHS FOR ONE TANK
ELEMENTS OF BLOCKS

Element	BLK	Comments	Unit	QTY	Wt (lb)	Vol (cu ft)	Area (sq ft)	Perim (ft)	Wt (lb)	Vol (cu ft)	Area (sq ft)	Perim (ft)
Bottom Block	1-1	Center-Line	8	52	66	114.5	171.8	293.05	37.4	293.05	37.4	293.05
Bottom Block	1-2	Center-Line	8	50	66	171.8	293.05	37.4	293.05	37.4	293.05	37.4
Bottom Block	2-1	Port 1-Sideband	4	148	158	237.7	395.6	500.62	62.26	500.62	62.26	500.62
Bottom Block	2-2	Port 2-Sideband	4	148	158	237.7	395.6	500.62	62.26	500.62	62.26	500.62
Bottom Block	4-1	Port 1-Sideband	4	148	158	237.7	395.6	500.62	62.26	500.62	62.26	500.62
Bottom Block	4-2	Port 2-Sideband	4	148	158	237.7	395.6	500.62	62.26	500.62	62.26	500.62
Side Block	6-1	Port 1-Sideband	2	152	145.0	403.0	642.00	804.00	60.20	804.00	60.20	804.00
Side Block	6-2	Port 2-Sideband	2	152	145.0	403.0	642.00	804.00	60.20	804.00	60.20	804.00
Backband Block	8-1	Center-Line	11	93	159.9	42.96	70.00	110.00	11.7	110.00	11.7	110.00
Backband Block	8-2	Center-Line	11	93	159.9	42.96	70.00	110.00	11.7	110.00	11.7	110.00
Deck Block	10-1	Port 1-Sideband	14	252	238.2	658.7	1065.00	1332.00	102.00	1332.00	102.00	1332.00
Deck Block	10-2	Port 2-Sideband	14	252	238.2	658.7	1065.00	1332.00	102.00	1332.00	102.00	1332.00
Deck Block	12-1	Port 1-Sideband	10	180	180.0	270.0	450.00	540.00	45.00	540.00	45.00	540.00
Deck Block	12-2	Port 2-Sideband	10	180	180.0	270.0	450.00	540.00	45.00	540.00	45.00	540.00
Deck Block	14-1	Port 1-Sideband	2	152	145.0	403.0	642.00	804.00	60.20	804.00	60.20	804.00
Deck Block	14-2	Port 2-Sideband	2	152	145.0	403.0	642.00	804.00	60.20	804.00	60.20	804.00
Total												

Welding Co. 60
Manual 29.1%
Automatic 70.9%

Flex 2, Box 1 (2) >> Auto Weld 1500
Flex 2, Box 1 (2) >> Manual Weld 1016
Flex 2, Box 1 (2) >> Manual Weld 7625
Flex 2, Box 1 (2) >> Manual Weld 2350
Flex 2, Box 1 (2) >> Manual Weld 8336
Flex 2, Box 1 (2) >> Manual Weld 1072
Flex 2, Box 1 (2) >> Manual Weld 2284
Flex 2, Box 1 (2) >> Manual Weld 2006
Flex 2, Box 1 (2) >> Manual Weld 1189

Alternative: 4080
Average 1 = 14.6

WEIGHTS AND WELENGTHS FOR ONE TANK
ELEMENTS OF BLOCKS

Element	BLK	Comments	Unit	QTY	Wt (lb)	Vol (cu ft)	Area (sq ft)	Perim (ft)	Wt (lb)	Vol (cu ft)	Area (sq ft)	Perim (ft)
Bottom Block	1-1	Center-Line	8	55	66	114.5	171.8	293.05	37.4	293.05	37.4	293.05
Bottom Block	1-2	Center-Line	8	50	66	171.8	293.05	37.4	293.05	37.4	293.05	37.4
Bottom Block	2-1	Port 1-Sideband	4	148	158	237.7	395.6	500.62	62.26	500.62	62.26	500.62
Bottom Block	2-2	Port 2-Sideband	4	148	158	237.7	395.6	500.62	62.26	500.62	62.26	500.62
Bottom Block	4-1	Port 1-Sideband	4	148	158	237.7	395.6	500.62	62.26	500.62	62.26	500.62
Bottom Block	4-2	Port 2-Sideband	4	148	158	237.7	395.6	500.62	62.26	500.62	62.26	500.62
Side Block	6-1	Port 1-Sideband	2	152	145.0	403.0	642.00	804.00	60.20	804.00	60.20	804.00
Side Block	6-2	Port 2-Sideband	2	152	145.0	403.0	642.00	804.00	60.20	804.00	60.20	804.00
Backband Block	8-1	Center-Line	11	98	159.9	42.96	70.00	110.00	11.7	110.00	11.7	110.00
Backband Block	8-2	Center-Line	11	98	159.9	42.96	70.00	110.00	11.7	110.00	11.7	110.00
Deck Block	10-1	Port 1-Sideband	14	252	238.2	658.7	1065.00	1332.00	102.00	1332.00	102.00	1332.00
Deck Block	10-2	Port 2-Sideband	14	252	238.2	658.7	1065.00	1332.00	102.00	1332.00	102.00	1332.00
Deck Block	12-1	Port 1-Sideband	10	180	180.0	270.0	450.00	540.00	45.00	540.00	45.00	540.00
Deck Block	12-2	Port 2-Sideband	10	180	180.0	270.0	450.00	540.00	45.00	540.00	45.00	540.00
Deck Block	14-1	Port 1-Sideband	2	152	145.0	403.0	642.00	804.00	60.20	804.00	60.20	804.00
Deck Block	14-2	Port 2-Sideband	2	152	145.0	403.0	642.00	804.00	60.20	804.00	60.20	804.00
Total												

Welding Co. 60
Manual 29.1%
Automatic 70.9%

Flex 2, Box 1 (2) >> Auto Weld 1500
Flex 2, Box 1 (2) >> Manual Weld 1016
Flex 2, Box 1 (2) >> Manual Weld 7625
Flex 2, Box 1 (2) >> Manual Weld 2350
Flex 2, Box 1 (2) >> Manual Weld 8336
Flex 2, Box 1 (2) >> Manual Weld 1072
Flex 2, Box 1 (2) >> Manual Weld 2284
Flex 2, Box 1 (2) >> Manual Weld 2006
Flex 2, Box 1 (2) >> Manual Weld 1189

Element	Welding Co.		Manual		Automatic		Welding Co.	Manual		Automatic		Welding Co.	Manual		Automatic	
	Wt	Vol	Wt	Vol	Wt	Vol		Wt	Vol	Wt	Vol		Wt	Vol	Wt	Vol
Bottom Block	103.2616	161.6284	103	39.536	98.4895	155.007	60	108	45.294	108	39.536	60	108	45.294	108	39.536
Bottom Block	227.96	359.802	227.96	359.802	227.96	359.802	60	227.96	359.802	227.96	359.802	60	227.96	359.802	227.96	359.802
Bottom Block	103.86	162.584	103.86	162.584	103.86	162.584	60	103.86	162.584	103.86	162.584	60	103.86	162.584	103.86	162.584
Bottom Block	419.242	668.204	419.242	668.204	419.242	668.204	60	419.242	668.204	419.242	668.204	60	419.242	668.204	419.242	668.204
Side Block	347.1994	551.946	347.1994	551.946	347.1994	551.946	60	347.1994	551.946	347.1994	551.946	60	347.1994	551.946	347.1994	551.946
Side Block	694.3988	1103.892	694.3988	1103.892	694.3988	1103.892	60	694.3988	1103.892	694.3988	1103.892	60	694.3988	1103.892	694.3988	1103.892
Backband Block	111.7	177.885	111.7	177.885	111.7	177.885	60	111.7	177.885	111.7	177.885	60	111.7	177.885	111.7	177.885
Backband Block	223.4	355.77	223.4	355.77	223.4	355.77	60	223.4	355.77	223.4	355.77	60	223.4	355.77	223.4	355.77
Deck Block	158.284	253.252	158.284	253.252	158.284	253.252	60	158.284	253.252	158.284	253.252	60	158.284	253.252	158.284	253.252
Deck Block	316.568	506.504	316.568	506.504	316.568	506.504	60	316.568	506.504	316.568	506.504	60	316.568	506.504	316.568	506.504
Deck Block	79.141	125.016	79.141	125.016	79.141	125.016	60	79.141	125.016	79.141	125.016	60	79.141	125.016	79.141	125.016
Deck Block	158.284	253.252	158.284	253.252	158.284	253.252	60	158.284	253.252	158.284	253.252	60	158.284	253.252	158.284	253.252
Total	3085.230	4882.752	3085.230	4882.752	3085.230	4882.752	60	3085.230	4882.752	3085.230	4882.752	60	3085.230	4882.752	3085.230	4882.752

Element	Welding Co.		Manual		Automatic		Welding Co.	Manual		Automatic		Welding Co.	Manual		Automatic	
	Wt	Vol	Wt	Vol	Wt	Vol		Wt	Vol	Wt	Vol		Wt	Vol	Wt	Vol
Bottom Block	115.007	184.011	115.007	184.011	115.007	184.011	60	115.007	184.011	115.007	184.011	60	115.007	184.011	115.007	184.011
Bottom Block	244.4784	391.165	244.4784	391.165	244.4784	391.165	6									

**Summary - 95KDWT Alternative Vessels
All Block Properties**

Alternatives Summary

Alternative	ELEMENTS OF BLOCKS										ELEMENTS OF BLOCKS										Total		
	BLK	Description	Item	Alt/Item	F/B	Angle	L	Bulb	Area	Weight	Area	Weight	Alt/Item	F/B	Angle	L	Bulb	Area	Weight	Area		Weight	
9510	9510	50000 Blank	15	245	3736	3433	2004	452.2	12430	11424	452.2	12430	11424	452.2	12430	11424	452.2	12430	11424	452.2	12430	11424	25144.0
9520	9520	Blank Mid Sheet	15	245	3736	3433	2004	452.2	12430	11424	452.2	12430	11424	452.2	12430	11424	452.2	12430	11424	452.2	12430	11424	25144.0
9530	9530	Non-SOC Dims	131	245	3837	3522	2005	462.2	12194	11802	462.2	12194	11802	462.2	12194	11802	462.2	12194	11802	462.2	12194	11802	24195.5
9539	9539	Blank/Congruent	142	240	3625	3402	2005	462.2	12394	11860	462.2	12394	11860	462.2	12394	11860	462.2	12394	11860	462.2	12394	11860	24195.5
9550	9550	Formstrip Side	157	2465	3737	3424	2005	452.2	12286	11728	452.2	12286	11728	452.2	12286	11728	452.2	12286	11728	452.2	12286	11728	24261.1
9560	9560	Blank/Whisper	149	2279	3643	3455	2135	462.2	12424	11900	462.2	12424	11900	462.2	12424	11900	462.2	12424	11900	462.2	12424	11900	24261.1
9570	9570	Blank/Blk Pits	181	245	3581			462.2	11544	11655	462.2	11544	11655	462.2	11544	11655	462.2	11544	11655	462.2	11544	11655	24261.1
9580	9580	Whisper Paints	81	2135	2594	6641		462.2	12264	11933	462.2	12264	11933	462.2	12264	11933	462.2	12264	11933	462.2	12264	11933	24261.1
9590	9590	UT Under cables	67	2375	3813	1442		557.7	11265	11450	557.7	11265	11450	557.7	11265	11450	557.7	11265	11450	557.7	11265	11450	6742.2
9592L	9592L	UT Un. sheave	67	2375	3813	1441		557.7	11265	11450	557.7	11265	11450	557.7	11265	11450	557.7	11265	11450	557.7	11265	11450	6742.2

Alternative: 9510

Element	ELEMENTS OF BLOCKS										ELEMENTS OF BLOCKS										Total		
	BLK	Description	Item	Alt/Item	F/B	Angle	L	Bulb	Area	Weight	Area	Weight	Alt/Item	F/B	Angle	L	Bulb	Area	Weight	Area		Weight	
Bottom Block	1-2	Part 2-1 Shellback	15	202	246			149.1	1094	134.6	149.1	1094	134.6	149.1	1094	134.6	149.1	1094	134.6	149.1	1094	134.6	2359.9
Bottom Block	1-2	Part 2-2 Shellback	8	161	185			155.2	737	103.9	155.2	737	103.9	155.2	737	103.9	155.2	737	103.9	155.2	737	103.9	1482.8
Bottom Block	3-2	Center-line	3	115	119			155.2	737	103.9	155.2	737	103.9	155.2	737	103.9	155.2	737	103.9	155.2	737	103.9	1482.8
Upper Block	4-1	Part 1-1 Shellback	18	164	96			308	1264	142.4	308	1264	142.4	308	1264	142.4	308	1264	142.4	308	1264	142.4	2703.1
Upper Block	5-1	Part 1-2 Shellback	26	302	742	752		308	1264	142.4	308	1264	142.4	308	1264	142.4	308	1264	142.4	308	1264	142.4	2703.1
Side Block	6-1	Part 7-1 Shellback	13	89	282	859		308	1264	142.4	308	1264	142.4	308	1264	142.4	308	1264	142.4	308	1264	142.4	1448.6
Side Block	8-2	Part 7-2 Shellback	9	166	710			48.2	622	103.5	48.2	622	103.5	48.2	622	103.5	48.2	622	103.5	48.2	622	103.5	855.2
Deck Block	10-1	Centerline	9	85	229	105		48.2	622	103.5	48.2	622	103.5	48.2	622	103.5	48.2	622	103.5	48.2	622	103.5	855.2
Deck Block	11-1	Centerline	9	85	229	105		48.2	622	103.5	48.2	622	103.5	48.2	622	103.5	48.2	622	103.5	48.2	622	103.5	855.2
Bottom Block	11-2	Centerline	9	85	229	105		48.2	622	103.5	48.2	622	103.5	48.2	622	103.5	48.2	622	103.5	48.2	622	103.5	855.2
Bottom Block	12-1	Centerline	9	85	229	105		48.2	622	103.5	48.2	622	103.5	48.2	622	103.5	48.2	622	103.5	48.2	622	103.5	855.2
Bottom Block	12-2	Centerline	9	85	229	105		48.2	622	103.5	48.2	622	103.5	48.2	622	103.5	48.2	622	103.5	48.2	622	103.5	855.2
Bottom Block	12-3	Centerline	9	85	229	105		48.2	622	103.5	48.2	622	103.5	48.2	622	103.5	48.2	622	103.5	48.2	622	103.5	855.2
Bottom Block	12-4	Centerline	9	85	229	105		48.2	622	103.5	48.2	622	103.5	48.2	622	103.5	48.2	622	103.5	48.2	622	103.5	855.2
Bottom Block	12-5	Centerline	9	85	229	105		48.2	622	103.5	48.2	622	103.5	48.2	622	103.5	48.2	622	103.5	48.2	622	103.5	855.2
Bottom Block	12-6	Centerline	9	85	229	105		48.2	622	103.5	48.2	622	103.5	48.2	622	103.5	48.2	622	103.5	48.2	622	103.5	855.2
Bottom Block	12-7	Centerline	9	85	229	105		48.2	622	103.5	48.2	622	103.5	48.2	622	103.5	48.2	622	103.5	48.2	622	103.5	855.2
Bottom Block	12-8	Centerline	9	85	229	105		48.2	622	103.5	48.2	622	103.5	48.2	622	103.5	48.2	622	103.5	48.2	622	103.5	855.2
Bottom Block	12-9	Centerline	9	85	229	105		48.2	622	103.5	48.2	622	103.5	48.2	622	103.5	48.2	622	103.5	48.2	622	103.5	855.2
Bottom Block	12-10	Centerline	9	85	229	105		48.2	622	103.5	48.2	622	103.5	48.2	622	103.5	48.2	622	103.5	48.2	622	103.5	855.2
Bottom Block	12-11	Centerline	9	85	229	105		48.2	622	103.5	48.2	622	103.5	48.2	622	103.5	48.2	622	103.5	48.2	622	103.5	855.2
Bottom Block	12-12	Centerline	9	85	229	105		48.2	622	103.5	48.2	622	103.5	48.2	622	103.5	48.2	622	103.5	48.2	622	103.5	855.2
Bottom Block	12-13	Centerline	9	85	229	105		48.2	622	103.5	48.2	622	103.5	48.2	622	103.5	48.2	622	103.5	48.2	622	103.5	855.2
Bottom Block	12-14	Centerline	9	85	229	105		48.2	622	103.5	48.2	622	103.5	48.2	622	103.5	48.2	622	103.5	48.2	622	103.5	855.2
Bottom Block	12-15	Centerline	9	85	229	105		48.2	622	103.5	48.2	622	103.5	48.2	622	103.5	48.2	622	103.5	48.2	622	103.5	855.2
Bottom Block	12-16	Centerline	9	85	229	105		48.2	622	103.5	48.2	622	103.5	48.2	622	103.5	48.2	622	103.5	48.2	622	103.5	855.2
Bottom Block	12-17	Centerline	9	85	229	105		48.2	622	103.5	48.2	622	103.5	48.2	622	103.5	48.2	622	103.5	48.2	622	103.5	855.2
Bottom Block	12-18	Centerline	9	85	229	105		48.2	622	103.5	48.2	622	103.5	48.2	622	103.5	48.2	622	103.5	48.2	622	103.5	855.2
Bottom Block	12-19	Centerline	9	85	229	105		48.2	622	103.5	48.2	622	103.5	48.2	622	103.5	48.2	622	103.5	48.2	622	103.5	855.2
Bottom Block	12-20	Centerline	9	85	229	105		48.2	622	103.5	48.2	622	103.5	48.2	622	103.5	48.2	622	103.5	48.2	622	103.5	855.2
Bottom Block	12-21	Centerline	9	85	229	105		48.2	622	103.5	48.2	622	103.5	48.2	622	103.5	48.2	622	103.5	48.2	622	103.5	855.2
Bottom Block	12-22	Centerline	9	85	229	105		48.2	622	103.5	48.2	622	103.5	48.2	622	103.5	48.2	622	103.5	48.2	622	103.5	855.2
Bottom Block	12-23	Centerline	9	85	229	105		48.2	622	103.5	48.2	622	103.5	48.2	622	103.5	48.2	622	103.5	48.2	622	103.5	855.2
Bottom Block	12-24	Centerline	9	85	229	105		48.2	622	103.5	48.2	622	103.5	48.2	622	103.5	48.2	622	103.5	48.2	622	103.5	855.2
Bottom Block	12-25	Centerline	9	85	229	105		48.2	622	103.5	48.2	622	103.5	48.2	622	103.5	48.2	622	103.5	48.2	622	103.5	855.2
Bottom Block	12-26	Centerline	9	85	229	105		48.2	622	103.5	48.2	622	103.5	48.2	622	103.5	48.2	622	103.5	48.2	622	103.5	855.2
Bottom Block	12-27	Centerline	9	85	229	105		48.2	622	103.5	48.2	622	103.5	48.2	622	103.5	48.2	622	103.5	48.2	622	103.5	855.2
Bottom Block	12-28	Centerline	9	85	229	105		48.2	622	103.5	48.2	622	103.5	48.2	622	103.5	48.2	622	103.5	48.2	622	103.5	855.2
Bottom Block	12-29	Centerline	9	85	229	105		48.2	622	103.5	48.2	622	103.5	48.2	622	103.5	48.2	622	103.5	48.2	622	103.5	855.2
Bottom Block	12-30	Centerline	9	85	22																		

Alternative: 9560
 Aveset = 15.2
 WEIGHTS AND WELD LENGTH FOR ONE TANK
 ELEMENTS OF BLOCKS

Element	BLK Comment	Unit	L (ft)	B (ft)	H (ft)	W (ft)	M (ft)	R (ft)	Welding Curved Plate		Welding Flat Plate		MANUAL	AUTOMATIC	No.		
									Weld	Weld	Weld	Weld					
Bottom Block	1-1 Port-2-Subtank	15	246	150	112.49	142.7	425.6	52.8	425.6	52.8	425.6	52.8	425.6	52.8	425.6	52.8	
Bottom Block	1-2 Port-2-Subtank	8	112	155	119	516	311.5	311.5	311.5	311.5	311.5	311.5	311.5	311.5	311.5	311.5	
Bottom Block	3-1 Center-line	3	119	119	516	155.2	739.7	603.9	415.2	415.2	415.2	415.2	415.2	415.2	415.2	415.2	
Bottom Block	3-2 Center-line	3	119	119	516	155.2	739.7	603.9	415.2	415.2	415.2	415.2	415.2	415.2	415.2	415.2	
Bottom Block	4-1 Port-1-Subtank	15	64	114	219	214.1	411.2	411.2	411.2	411.2	411.2	411.2	411.2	411.2	411.2	411.2	
Bottom Block	6-1 Port-1-Subtank	26	302	752	1264.9	1264.9	440.4	667.8	667.8	667.8	667.8	667.8	667.8	667.8	667.8	667.8	
Bottom Block	6-2 Port-1-Subtank	17	203	646	859	316	822.5	603.5	280.2	280.2	280.2	280.2	280.2	280.2	280.2	280.2	
Bottom Block	8-1 Port-1-Subtank	4	166	710	1217	40.2	154.8	61.9	109.8	109.8	109.8	109.8	109.8	109.8	109.8	109.8	
Bottom Block	10-1 Centerline	5	70	132	129	41.4	159.1	175.8	41.4	41.4	41.4	41.4	41.4	41.4	41.4	41.4	
Bottom Block	11-1 Centerline	11	122	132	129	41.4	159.1	175.8	41.4	41.4	41.4	41.4	41.4	41.4	41.4	41.4	
Bottom Block	11-2 Centerline	11	122	132	129	41.4	159.1	175.8	41.4	41.4	41.4	41.4	41.4	41.4	41.4	41.4	
Bottom Block	12-1 13-1 Port & Bld	13	236	876	1807.2	210.2	410.3	410.3	410.3	410.3	410.3	410.3	410.3	410.3	410.3	410.3	
TOTAL			149	2279	16834	17428	14900	65275	45353	125.6	81477	10317	40189	57.6	230.2	476.7	84.8

Notes: 16740 7247 5700 18230 3214 10138 38348 7416
 Accumulation Unit Film Flat Horiz Vert Overhead

Flux 2, Bldx 55-Auto-Weld
 Notes: 1819
 Film Flat Horiz Vert Overhead

Flux 2, Bldx 55-Manual Weld
 Notes: 8941
 Vertical Overhead
 Film Flat Horiz Vert Overhead

Flux 2, Bldx 55-Manual Weld
 Notes: 696.7
 Vertical Overhead
 Film Flat Horiz Vert Overhead

Flux 2, Bldx 55-Manual Weld
 Notes: 394.8
 Vertical Overhead
 Film Flat Horiz Vert Overhead

Alternative: 9570
 Aveset = 16.4
 WEIGHTS AND WELD LENGTH FOR ONE TANK
 ELEMENTS OF BLOCKS

Element	BLK Comment	Unit	L (ft)	B (ft)	H (ft)	W (ft)	M (ft)	R (ft)	Welding Curved Plate		Welding Flat Plate		MANUAL	AUTOMATIC	No.		
									Weld	Weld	Weld	Weld					
Bottom Block	1-1 Port-2-Subtank	15	246	150	112.49	142.7	425.6	52.8	425.6	52.8	425.6	52.8	425.6	52.8	425.6	52.8	
Bottom Block	1-2 Port-2-Subtank	8	112	155	119	516	311.5	311.5	311.5	311.5	311.5	311.5	311.5	311.5	311.5	311.5	
Bottom Block	3-1 Center-line	3	119	119	516	155.2	739.7	603.9	415.2	415.2	415.2	415.2	415.2	415.2	415.2	415.2	
Bottom Block	3-2 Center-line	3	119	119	516	155.2	739.7	603.9	415.2	415.2	415.2	415.2	415.2	415.2	415.2	415.2	
Bottom Block	4-1 Port-1-Subtank	15	64	114	219	214.1	411.2	411.2	411.2	411.2	411.2	411.2	411.2	411.2	411.2	411.2	
Bottom Block	6-1 Port-1-Subtank	26	302	752	1264.9	1264.9	440.4	667.8	667.8	667.8	667.8	667.8	667.8	667.8	667.8	667.8	
Bottom Block	6-2 Port-1-Subtank	17	203	646	859	316	822.5	603.5	280.2	280.2	280.2	280.2	280.2	280.2	280.2	280.2	
Bottom Block	8-1 Port-1-Subtank	4	166	710	1217	40.2	154.8	61.9	109.8	109.8	109.8	109.8	109.8	109.8	109.8	109.8	
Bottom Block	10-1 Centerline	5	70	132	129	41.4	159.1	175.8	41.4	41.4	41.4	41.4	41.4	41.4	41.4	41.4	
Bottom Block	11-1 Centerline	11	122	132	129	41.4	159.1	175.8	41.4	41.4	41.4	41.4	41.4	41.4	41.4	41.4	
Bottom Block	11-2 Centerline	11	122	132	129	41.4	159.1	175.8	41.4	41.4	41.4	41.4	41.4	41.4	41.4	41.4	
Bottom Block	12-1 13-1 Port & Bld	13	236	876	1807.2	210.2	410.3	410.3	410.3	410.3	410.3	410.3	410.3	410.3	410.3	410.3	
TOTAL			151	2457	16834	17428	14900	65275	45353	125.6	81477	10317	40189	57.6	230.2	476.7	84.8

Notes: 11145 7108 6507 12408 8883 10030 37160 546.1
 Accumulation Unit Film Flat Horiz Vert Overhead

Flux 2, Bldx 55-Auto-Weld
 Notes: 15200
 Film Flat Horiz Vert Overhead

Flux 2, Bldx 55-Manual Weld
 Notes: 7228
 Downward
 Film Flat Horiz Vert Overhead

Flux 2, Bldx 55-Manual Weld
 Notes: 581.2
 Downward
 Film Flat Horiz Vert Overhead

Flux 2, Bldx 55-Manual Weld
 Notes: 854.4
 Downward
 Film Flat Horiz Vert Overhead

Flux 2, Bldx 55-Manual Weld
 Notes: 223.2
 Vertical
 Film Flat Horiz Vert Overhead

Flux 2, Bldx 55-Manual Weld
 Notes: 353.9
 Vertical
 Film Flat Horiz Vert Overhead

Flux 2, Bldx 55-Manual Weld
 Notes: 228.6
 Vertical
 Film Flat Horiz Vert Overhead

Alternative: 9580
 Aveset = 16.4
 WEIGHTS AND WELD LENGTH FOR ONE TANK
 ELEMENTS OF BLOCKS

Element	BLK Comment	Unit	L (ft)	B (ft)	H (ft)	W (ft)	M (ft)	R (ft)	Welding Curved Plate		Welding Flat Plate		MANUAL	AUTOMATIC	No.		
									Weld	Weld	Weld	Weld					
Bottom Block	1-1 Port-2-Subtank	12	178	145	805	155.2	149.12	121.58	152.2	152.2	152.2	152.2	152.2	152.2	152.2	152.2	
Bottom Block	1-2 Port-2-Subtank	2	111	158.4	366.6	652.6	64.2	64.2	64.2	64.2	64.2	64.2	64.2	64.2	64.2	64.2	
Bottom Block	3-1 Center-line	3	119	119	516	155.2	739.7	603.9	415.2	415.2	415.2	415.2	415.2	415.2	415.2	415.2	
Bottom Block	3-2 Center-line	3	119	119	516	155.2	739.7	603.9	415.2	415.2	415.2	415.2	415.2	415.2	415.2	415.2	
Bottom Block	4-1 Port-1-Subtank	14	64	114	219	214.1	411.2	411.2	411.2	411.2	411.2	411.2	411.2	411.2	411.2	411.2	
Bottom Block	4-2 Port-1-Subtank	18	72	126	267.7	316	421.5	316	316	316	316	316	316	316	316	316	
Bottom Block	6-1 Port-1-Subtank	26	302	752	1264.9	1264.9	440.4	667.8	667.8	667.8	667.8	667.8	667.8	667.8	667.8	667.8	
Bottom Block	6-2 Port-1-Subtank	17	203	646	859	316	822.5	603.5	280.2	280.2	280.2	280.2	280.2	280.2	280.2	280.2	
Bottom Block	8-1 Port-1-Subtank	4	166	710	1217	40.2	154.8	61.9	109.8	109.8	109.8	109.8	109.8	109.8	109.8	109.8	
Bottom Block	10-1 Centerline	5	70	132	129	41.4	159.1	175.8	41.4	41.4	41.4	41.4	41.4	41.4	41.4	41.4	
Bottom Block	11-1 Centerline	11	122	132	129	41.4	159.1	175.8	41.4	41.4	41.4	41.4	41.4	41.4	41.4	41.4	
Bottom Block	11-2 Centerline	11	122	132	129	41.4	159.1	175.8	41.4	41.4	41.4	41.4	41.4	41.4	41.4	41.4	
Bottom Block	12-1 13-1 Port & Bld	13	236	876	1807.2	210.2	410.3	410.3	410.3	410.3	410.3	410.3	410.3	410.3	410.3	410.3	
TOTAL			87	2159	16834	17428	14900	65275	45353	125.6	81477	10317	40189	57.6	230.2	476.7	84.8

Notes: 7315 6784 4656 6501 5127 4840 41035 421.5
 Accumulation Unit Film Flat Horiz Vert Overhead

Flux 2, Bldx 55-Auto-Weld
 Notes: 6404
 Film Flat Horiz Vert Overhead

Flux 2, Bldx 55-Manual Weld
 Notes: 2885
 Downward
 Film Flat Horiz Vert Overhead

Flux 2, Bldx 55-Manual Weld
 Notes: 3600
 Downward
 Film Flat Horiz Vert Overhead

Flux 2, Bldx 55-Manual Weld
 Notes: 355.4
 Downward
 Film Flat Horiz Vert Overhead

Flux 2, Bldx 55-Manual Weld
 Notes: 1365
 Vertical
 Film Flat Horiz Vert Overhead

Flux 2, Bldx 55-Manual Weld
 Notes: 562.7
 Vertical
 Film Flat Horiz Vert Overhead

Flux 2, Bldx 55-Manual Weld
 Notes: 109.4
 Vertical
 Film Flat Horiz Vert Overhead

Flux 2, Bldx 55-Manual Weld
 Notes: 102.6
 Vertical
 Film Flat Horiz Vert Overhead

**Summary - 40KDWT Alternative Vessels
No. Pieces, Area, Weight**

Alternatives Summary

WEIGHTS AND WELD VOLUME FOR VARIOUS ALTERNATIVES
ELEMENTS OF BLOCKS - ONE TANK LENGTH

Alternative	BLK	Description	Unique Item	Total # of Items	L F:B (m)	L Angle (m)	L Tee (m)	L Bulb (m)	Area Curve Pl (M ²)	Area of Plate (M ²)	Weight Item (MT)
<u>4010</u>		40KDWT Base Vessel	157	1642	2215	2357	931		182.0	7353.4	846.7
<u>4020</u>		Base Mild Steel	157	1642	2215	2357	931		182.0	7467.9	870.7
<u>4030</u>		B w/additional choice stiff	195	1646	2258	2357	931		182.0	7257.0	840.3
<u>4040</u>		B w/Corrugated bhd	155	1566	2215	1789	931		117.4	7309.9	841.0
<u>4050</u>		B w/ formed Hop	159	1650	2215	2414	967		182.0	7287.9	839.7
<u>4060</u>		B w/ hopper side	170	1810	2359	2307	931		182.0	7185.5	829.6
<u>4070</u>		B w/Bulbs	223	1642	2215		3238		182.0	6803.6	841.3
<u>4080</u>		B w/Pit Ang combination	96	1530	1606	3828			182.0	7288.0	840.5
<u>4090</u>		B w/Fir, etc Stiff Auto Weld	157	1642	2214	2356	930.		182.0	7353.4	846.7
<u>40100</u>		U4 Unidirect w/ Corrugate	133	1360	1295	653			117.4	8971.7	1455.5
<u>40110</u>		U5 w/corrugated bhd	105	992	829	466		512	117.4	8291.3	1178.2
<u>40111</u>		U5 w/double plate bhd	107	998	829	466		512	117.4	8597.7	1213.3
<u>40112</u>		U5 w/corrug & HTS D&B no CL bhd	86	854	781	328		512	117.4	7087.1	979.1
<u>40120</u>		U6 Dished plate	67	2116	3448	1306			2931.6	8155.3	1369.5
<u>40121</u>		U6 Dished Plate/rev	67	2116	3448	1306			2931.6	8155.3	1369.5
<u>40130</u>		B w/Slotted I.B.	157	1642	2214	2356	930.		182.0	7353.4	846.7
<u>40140</u>		B w/Stand & Series	157	1642	2214	2356	930.		182.0	7353.4	846.7
<u>40150</u>		B w/Std Design	157	1642	2214	2356	930.		182.0	7353.4	846.7

**Summary - 95KDWT Alternative Vessels
No. Pieces, Area, Weight**

Alternatives Summary

WEIGHTS AND WELD VOLUME FOR VARIOUS ALTERNATIVES
ELEMENTS OF BLOCKS

Alternative	Description	Unique Item	Total # of Items	# Ea. L	L F.B (m)	L Angle (m)	L Tee (m)	L Bulb (m)	Length /Width (m)	Area Curve Pl (M ^ 2)	Area of Plate (M ^ 2)	Weight Item (MT)
<u>9510</u>	95KDWT Base Vessel	153	2457		3796	3433	2004			452.2	12296.8	1472.9
<u>9520</u>	Base Mild Steel	153	2457		3796	3433	2004			452.2	12498.0	1587.0
<u>9530</u>	Non Std Stiffnrs	191	2457		3897	3922	2005			452.2	12194.2	1580.5
<u>9540</u>	Base w/Corrugated	142	2440		3603	3402	2005			452.2	12364.7	1486.0
<u>9550</u>	Formed Hpr Side	157	2465		3797	3434	2005			452.2	12296.8	1472.8
<u>9560</u>	Bkt in lieu Hopper	149	2279		3643	3405	2105			452.2	12424.6	1490.0
<u>9570</u>	Base w/Bulb Flats	181	2457		2581			6533		452.2	11544.6	1496.5
<u>9580</u>	W/angle Plt units	83	2133		2594	6641				452.2	12264.4	1490.9
<u>95120</u>	U3 Unidir dished	67	2375		3813	1441				5579.6	11263.52	1944.
<u>95121</u>	U3 Uni dished/rev	67	2375		3813	1441				5579.6	11263.52	1944.

**Summary - 40KDWT Alternative Vessels
Weld Volume, Auto, Manual, Fillet, Butt**

Alternatives Summary

WELDING VOLUMES
ONE TANK LENGTH

Alternative	Description	Welding Flat Plate						Welding Curved Plate						Sum Welds 15284.0
		Automatic			Manual			Automatic			Manual			
		fillet	one sided t <= 19mm (cm2-M)	two sided t > 19mm (cm2-M)	fillet	t <= 19mm (cm2-M)	t > 19mm (cm2-M)	fillet	t <= 19mm (cm2-M)	t > 19mm (cm2-M)	fillet	t <= 19mm (cm2-M)	t > 19mm (cm2-M)	
4010	40XDMT Base Vessel	3138.0	2140.2	5502.2	1450.9	2842.3	60.0	58.3	58.3	29.1	63.0	63.0	63.0	63.0
4020	Base Mild Steel	3135.7	2201.2	5419.5	1450.9	3094.3	60.0	58.3	58.3	29.1	71.4	71.4	71.4	71.4
4030	B w/additional choice stiff	3157.2	2140.2	5502.2	1450.9	2853.3	60.0	58.3	58.3	29.1	63.0	63.0	63.0	63.0
4040	B w/Corrugated bhd	2687.5	1991.5	7459.4	1566.2	2716.6	60.0	58.3	58.3	29.1	63.0	63.0	63.0	63.0
4050	B w/formed bhd	3138.9	2197.8	5399.5	1439.0	3144.2	60.0	58.3	58.3	29.1	61.0	61.0	61.0	61.0
4060	B w/ hopper side	3085.2	1897.9	6653.5	1439.0	3094.0	60.0	58.3	58.3	29.1	63.0	63.0	63.0	63.0
4070	B w/Bulbs	2110.8	2218.7	5417.3	1354.7	2524.8	277.5	58.3	58.3	29.1	94.5	94.5	94.5	94.5
4080	B w/Pt Ang combination	412.6	423.9	4982.7	1439.0	2380.9	60.0	58.3	58.3	29.1	63.0	63.0	63.0	63.0
4090	B w/Fr, etc Stiff Auto Weld	4342.7	2140.2	3092.8	1450.9	2842.3	60.0	58.3	58.3	29.1	63.0	63.0	63.0	63.0
40100	U4 Undirect w/ Corrugate	869.1	2515.4	4733.4	4816.0	5773.2	7105.2	138.8	138.8	29.1	138.8	138.8	138.8	138.8
40110	U5 w/corrugated bhd	602.2	1831.5	3325.6	3919.5	4869.2	4262.3	138.8	138.8	29.1	138.8	138.8	138.8	138.8
40111	U5 w/double plate bhd	1015.1	1311.1	3723.4	3976.3	4980.6	4434.2	110.3	110.3	29.1	110.3	110.3	110.3	110.3
40112	U5 w/corrug & HTS D&B no CLbhd	428.1	984.5	3078.9	2570.7	4139.6	3757.8	5835.1	5835.1	29.1	5835.1	5835.1	5835.1	5835.1
40120	U6 Dished plate	1033.8	72.7	3480.9	2733.0	976.9	1862.2	5835.1	5835.1	29.1	5835.1	5835.1	5835.1	5835.1
40121	U6 Dished Plate/rev	1791.0	1150.5	1823.5	375.3	976.9	1862.2	5835.1	5835.1	29.1	5835.1	5835.1	5835.1	5835.1
40140	B w/Slotted I.B.	3138.0	2140.2	5502.2	1450.9	2842.3	60.0	58.3	58.3	29.1	63.0	63.0	63.0	63.0
40150	B w/Stand.&Series	3138.0	2140.2	5502.2	1450.9	2842.3	60.0	58.3	58.3	29.1	63.0	63.0	63.0	63.0
40130	B w/Std Design	3138.0	2140.2	5502.2	1450.9	2842.3	60.0	58.3	58.3	29.1	63.0	63.0	63.0	63.0

**Summary - 95KDWT Alternative Vessels
Weld Volume, Auto, Manual, Fillet, Butt**

Alternatives Summary

Alternative	Description	Welding Flat Plate						Welding Curved Plate						Sum Welds 25144.0
		Automatic			Manual			Automatic			Manual			
		fill let	one sided t <= 19mm (cm2-M)	two sided t <= 19mm (cm2-M)	fill let	t <= 19mm (cm2-M)	t > 19mm (cm2-M)	fill let	t <= 19mm (cm2-M)	t > 19mm (cm2-M)	fill let	t <= 19mm (cm2-M)	t > 19mm (cm2-M)	
<u>9510</u>	95KDW Base Vess	5155.7	4465.9	105.6	8570.4	1174.8	4822.3	57.6	230.2	476.7	476.7	84.8	25144.0	
<u>9520</u>	Base Mild Steel	4532.0	3925.4	2075.6	8484.7	1456.3	4090.4	2241.5	257.3	476.7	476.7	94.7	28185.9	
<u>9530</u>	Non Std Stiffns	4899.0	4513.2	105.6	7840.0	1180.6	4771.7	57.6	230.2	476.7	476.7	84.8	24159.5	
<u>9540</u>	Base w/Corrugated	5543.7	5410.1	105.6	8326.2	791.5	4399.3	115.2	230.2	476.7	476.7	84.8	25483.4	
<u>9550</u>	Formed Hpr Side	5163.9	4949.0	105.6	8026.1	1193.8	5035.6	57.6	230.2	476.7	476.7	84.8	25932.3	
<u>9560</u>	Bkt in lieu Hopper	5257.5	4575.9	105.6	8414.7	1061.7	4818.8	57.6	230.2	476.7	476.7	84.8	25083.4	
<u>9570</u>	Base w/Bulb Flats	3761.3	3743.4	1308.5	8310.6	1315.3	3598.9	1413.4	230.2	476.7	476.7	84.8	24243.1	
<u>9580</u>	W/angle Pit units	325.3	566.1	105.6	7744.8	1095.0	3734.3	51.6	230.2	238.3	238.3	84.8	14176.0	
<u>95120</u>	U3 Unidir dished	1147.4	874.6	43825.1	3916.4	2247.2	982.4	2300.1		223.8	223.8	6764.2	62354.0	
<u>95121</u>	U3 Uni dished/rev	2007.8	641.4	14608.4	1963.9	381.0	909.3	2300.1		223.8	223.8	6764.2	30725.5	

**Summary - 40DWT Alternative Vessels
Weld Lengths**

Alternatives Summary

WELDING LENGTHS
ONE TANK LENGTH

Alternative	Description	Average t mm	Auto matic				Manual				
			Fillet		Butt		Fillet		Butt		
			M	M	M	M	M	M	M	M	
4010	40KDWT Base Vessel	14.65	15196.0	1084.5	6797.5	1390.0	368.7	485.1	99.2	26.3	25447.5
4020	Base Mild Steel	14.83	15118.5	1086.0	6848.0	1401.3	370.3	491.9	100.7	26.6	25443.2
4030	B w/additional choice stiff	14.73	15286.0	1083.5	6871.6	1375.3	305.3	487.1	97.5	21.6	25528.0
4040	B w/Corrugated bhd	14.64	13497.2	962.2	6821.0	1903.5	413.4	486.2	135.7	29.5	24248.5
4050	B w/ formed Hop	14.66	15279.3	1124.4	6901.9	1389.0	378.2	507.9	102.2	27.8	25710.9
4060	B w/ hopper side	14.69	15089.7	1016.5	7625.2	1591.8	339.1	513.7	107.2	22.8	26306.0
4070	B w/Bulbs	15.73	9247.4	928.3	5738.1	1529.6	369.3	576.0	153.6	37.1	18579.4
4080	B w/Plt Ang combination	14.67	4486.7	1280.0	3297.6	1177.9	279.9	940.8	336.1	79.9	11879.0
4090	B w/Flr,etc.Stiff Auto Weld	14.65	17695.1	1262.9	4812.1	984.0	261.0	343.4	70.2	18.6	25447.5
40100	U4 Unidirectional w/corr	20.64	4932.8	856.5	4131.9	1514.2	593.9	717.4	262.9	103.1	13112.7
40110	U5 w/corrugated bhd	18.08	5180.1	964.8	4096.6	1392.0	597.5	763.0	259.3	111.3	13364.4
40111	U5 w/double plate bhd	17.96	3928.4	905.5	3302.4	1123.4	561.7	761.2	259.0	129.5	10971.1
40112	U5 w/corrug & HTS D & B no CL bhd	17.58	5436.6	1036.2	4227.4	1404.6	584.2	805.8	267.7	111.3	13873.8
40120	U6 Dished plate	21.37	8433.1	1107.0	3710.7	3039.3	262.8	487.1	399.0	34.5	17473.3
40121	U6 Dished Plate/rev	21.37	11703.8	1596.7	2666.0	370.4	120.9	363.7	50.5	16.5	16888.5
40130	B w/Slotted I.B.	14.65	15196.0	1084.5	6797.5	1390.0	368.7	485.1	99.2	26.3	25447.5
40140	B w/Stand & Series	14.65	15196.0	1084.5	6797.5	1390.0	368.7	485.1	99.2	26.3	25447.5
40150	B w/Std Design	14.65	15196.0	1084.5	6797.5	1390.0	368.7	485.1	99.2	26.3	25447.5

**Summary - 95DWT Alternative Vessels
Weld Lengths**

Alternatives Summary

WELDING LENGTHS IN METERS
ONE TANK LENGTH

Alternative	Description	Averg thk mm	Auto matic						Manual						
			Fillet		Butt		Fillet		Butt		Fillet		Butt		
			M	M	M	M	M	M	M	M	M	M	M	M	M
<u>9510</u>	95KDWT Base Vessel	15.24	25165	1919	9380	2002	355	715	153	27	39715				
<u>9520</u>	Base Mild Steel	16.16	25074	1916	9448	2024	357	722	155	27	39722				
<u>9530</u>	Non Std Stiffnrs	16.49	25591	1936	9247	1982	328	700	150	25	39957				
<u>9540</u>	Base w/Corrugated	15.29	25763	2146	8951	1692	326	746	141	27	39793				
<u>9550</u>	Formed Hpr Side	15.24	25315	2064	9003	1906	348	734	155	28	39554				
<u>9560</u>	Bkt in lieu Hopper	15.26	25530	1989	8942	1766	343	697	138	27	39431				
<u>9570</u>	Base w/Bulb Flats	16.49	15210	1686	7528	2014	351	834	223	39	27886				
<u>9580</u>	W/angle Pit units	15.47	6404	2286	3830	1577	365	1367	563	130	16522				
<u>95120</u>	U3 Unidir dished	21.97	10278	1733	3301	3334	241	556	562	41	20045				
<u>95121</u>	U3 Uni dished/rev	21.97	13422	2351	2743	234	110	480	41	19	19400				

PAGE NOT USED

PAGE NOT USED

**40KDWT Alternative Vessels
Estimation of Labor Hours Calculations for One Tank**

NSRP PANEL SP-4
 FILE: STRCTMS Revised

LABOR HOUR ESTIMATING FORM FOR STRUCTURAL WORK
 40KDWT BASE ALTERNATIVE
 Entire Tank Section MATERIAL: MS-ST5
 4010 THICKNESS 0.57 INCHES

WORK PROCESS	WORK UNITS	PROCESS FACTOR (MNHRS/ WORK UNIT)	UNIT AMOUNT	ACTUAL STAGE	STANDARD STAGE	ACTUAL FACTOR	STANDARD FACTOR	MNHRS REQ'D
1 OBTAIN MATERIAL RECEIPT & PREP	SQ FT	0.010	79149	1	1	1.0	1.0	791
2 FLAME CUTTING								
AUTOMATIC	LN FT	0.040	47582	1	1	1.0	1.0	1885
MANUAL	LN FT	0.071	2504	2	2	1.5	1.5	179
3 EDGE PREP-GRINDING								
FLAT	LN FT	0.032	1990	1	2	1.0	1.5	63
VERTICAL	LN FT	0.048	407	2	2	1.5	1.5	19
OVERHEAD	LN FT	0.063	108	2	2	1.5	1.5	7
4 SHAPING								
BREAK	BEND	0.380	0	1	1	1.0	1.0	0
ROLLING	PIECE	0.951	4	1	1	1.0	1.0	4
LINE HEATING	PIECE	10.000	0	1	1	1.0	1.0	0
FURNACE	PIECE	15.000	0	1	1	1.0	1.0	0
PRESS	PIECE	0.019	0	1	1	1.0	1.0	0
MACHINING	CU IN	0.020	0	1	1	1.0	1.0	0
5 FIT UP & ASSEMBLY	JOINT	0.444	6568	2	2	1.5	1.5	2915
6 WELDING, AUTO/MACHINE								
FILLET	LN FT	0.052	49968	2	2	1.5	1.5	2574
BUTT	LN FT	0.3804	3530	2	2	1.5	1.5	1343
7 WELDING, MANUAL								
FILLET								
DOWNHAND	LN FT	0.269	22352	2	2	1.5	1.5	6023
VERTICAL	LN FT	0.404	4571	2	2	1.5	1.5	1847
OVERHEAD	LN FT	0.539	1213	2	2	1.5	1.5	653
BUTT								
DOWNHAND	LN FT	1.030	1579	2	2	1.5	1.5	1627
VERTICAL	LN FT	1.545	323	2	2	1.5	1.5	499
OVERHEAD	LN FT	2.061	86	2	2	1.5	1.5	177
8 MARKING	PIECE	0.100	1642	1	1	1.0	1.0	164
9 HANDLING								
STORAGE	PIECE	0.100	1642	2	2	1.5	1.5	164
TRANSPORTING	ASSY	5.000	24	3	3	2.0	2.0	120
LIFTING	ASSY	5.000	24	4	4	3.0	3.0	120
10 REWORK	JOINT	1.000	660	5	2	4.5	1.5	1981
TOTAL TRADE LABORHOURS								23156
TRADE SUPPORT LABORHOURS (28% OF TRADE LABORHOURS)								6423
TOTAL PRODUCTION LABORHOURS								29578

NSRP PANEL SP-4
 FILE: STRCTMS Revised

LABOR HOURS ESTIMATING FORM FOR STRUCTURAL WORK
 40KDWT BASE ALTERNATIVE

PROJECT:
 FILE :

Entire Tank Section MATERIAL: MS-ST5
 4020 THICKNESS 0.58 INCHES

WORK PROCESS	WORK UNITS	PROCESS FACTOR (MNHRS/WORK UNIT)	UNIT AMOUNT	ACTUAL STAGE	STANDARD STAGE	ACTUAL FACTOR	STANDARD FACTOR	MNHRS REQ'D
1 OBTAIN MATERIAL RECEIPT & PREP	SQ FT	0.010	80382	1	1	1.0	1.0	804
2 FLAME CUTTING								
AUTOMATIC	LN FT	0.040	47622	1	1	1.0	1.0	1887
MANUAL	LN FT	0.071	2506	2	2	1.5	1.5	179
3 EDGE PREP-GRINDING								
FLAT	LN FT	0.032	1991	1	2	1.0	1.5	63
VERTICAL	LN FT	0.048	407	2	2	1.5	1.5	19
OVERHEAD	LN FT	0.063	108	2	2	1.5	1.5	7
4 SHAPING								
BREAK	BEND	0.380	0	1	1	1.0	1.0	0
ROLLING	PIECE	0.951	4	1	1	1.0	1.0	4
LINE HEATING	PIECE	10.000	0	1	1	1.0	1.0	0
FURNACE	PIECE	15.000	0	1	1	1.0	1.0	0
PRESS	PIECE	0.019	0	1	1	1.0	1.0	0
MACHINING	CU IN	0.020	0	1	1	1.0	1.0	0
5 FIT UP & ASSEMBLY	JOINT	0.444	6568	2	2	1.5	1.5	2915
6 WELDING, AUTO/MACHINE								
FILLET	LN FT	0.052	49601	2	2	1.5	1.5	2555
BUTT	LN FT	0.3804	3563	2	2	1.5	1.5	1355
7 WELDING, MANUAL								
FILLET								
DOWNHAND	LN FT	0.269	22467	2	2	1.5	1.5	6054
VERTICAL	LN FT	0.404	4597	2	2	1.5	1.5	1858
OVERHEAD	LN FT	0.539	1215	2	2	1.5	1.5	655
BUTT								
DOWNHAND	LN FT	1.030	1614	2	2	1.5	1.5	1663
VERTICAL	LN FT	1.545	330	2	2	1.5	1.5	510
OVERHEAD	LN FT	2.061	87	2	2	1.5	1.5	180
8 MARKING	PIECE	0.100	1642	1	1	1.0	1.0	164
9 HANDLING								
STORAGE	PIECE	0.100	1642	2	2	1.5	1.5	164
TRANSPORTING	ASSY	5.000	24	3	3	2.0	2.0	120
LIFTING	ASSY	5.000	24	4	4	3.0	3.0	120
10 REWORK	JOINT	1.000	663	5	2	4.5	1.5	1990
TOTAL TRADE LABORHOURS								23266
TRADE SUPPORT LABORHOURS (28% OF TRADE LABORHOURS)								6453
TOTAL PRODUCTION LABORHOURS								29719

NSRP PANEL SP-4
 FILE: STRCTMS Revised

LABOR HOUR ESTIMATING FORM FOR STRUCTURAL WORK
 40KDWT BASE ALTERNATIVE

PROJECT: Entire Tank Section MATERIAL: MS-STS
 FILE: 4030 THICKNESS 0.58 INCHES

WORK PROCESS	WORK UNITS	PROCESS FACTOR (MNHRS/ WORK UNIT)	UNIT AMOUNT	ACTUAL STAGE	STANDARD STAGE	ACTUAL FACTOR	STANDARD FACTOR	MNHRS REQ'D
1 OBTAIN MATERIAL RECEIPT & PREP	SQ FT	0.010	78112	1	1	1.0	1.0	781
2 FLAME CUTTING								
AUTOMATIC	LN FT	0.040	47682	1	1	1.0	1.0	1889
MANUAL	LN FT	0.071	2510	2	2	1.5	1.5	179
3 EDGE PREP-GRINDING								
FLAT	LN FT	0.032	2016	1	2	1.0	1.5	64
VERTICAL	LN FT	0.048	404	2	2	1.5	1.5	19
OVERHEAD	LN FT	0.063	90	2	2	1.5	1.5	6
4 SHAPING								
BREAK	BEND	0.380	0	1	1	1.0	1.0	0
ROLLING	PIECE	0.951	4	1	1	1.0	1.0	4
LINE HEATING	PIECE	10.000	0	1	1	1.0	1.0	0
FURNACE	PIECE	15.000	0	1	1	1.0	1.0	0
PRESS	PIECE	0.019	0	1	1	1.0	1.0	0
MACHINING	CU IN	0.020	0	1	1	1.0	1.0	0
5 FIT UP & ASSEMBLY	JOINT	0.444	6584	2	2	1.5	1.5	2922
6 WELDING, AUTO/MACHINE								
FILLET	LN FT	0.052	50150	2	2	1.5	1.5	2583
BUTT	LN FT	0.3804	3555	2	2	1.5	1.5	1352
7 WELDING, MANUAL								
FILLET								
DOWNHAND	LN FT	0.269	22544	2	2	1.5	1.5	6075
VERTICAL	LN FT	0.404	4512	2	2	1.5	1.5	1824
OVERHEAD	LN FT	0.539	1002	2	2	1.5	1.5	540
BUTT								
DOWNHAND	LN FT	1.030	1598	2	2	1.5	1.5	1646
VERTICAL	LN FT	1.545	320	2	2	1.5	1.5	494
OVERHEAD	LN FT	2.061	71	2	2	1.5	1.5	146
8 MARKING	PIECE	0.100	1646	1	1	1.0	1.0	165
9 HANDLING								
STORAGE	PIECE	0.100	1646	2	2	1.5	1.5	165
TRANSPORTING	ASSY	5.000	24	3	3	2.0	2.0	120
LIFTING	ASSY	5.000	24	4	4	3.0	3.0	120
10 REWORK	JOINT	1.000	658	5	2	4.5	1.5	1974
TOTAL TRADE LABORHOURS								23068
TRADE SUPPORT LABORHOURS (28% OF TRADE LABORHOURS)								6398
TOTAL PRODUCTION LABORHOURS								29466

NSRP PANEL SP-4
 FILE: STRCTMS Revised

COST ESTIMATING FORM FOR STRUCTURAL WORK
 40KDWT BASE ALTERNATIVE
 Entire Tank Section MATERIAL: MS-ST5
 4040 THICKNESS 0.57 INCHES

WORK PROCESS	WORK UNITS	PROCESS FACTOR (MNHRS/WORK UNIT)	UNIT AMOUNT	ACTUAL STAGE	STANDARD STAGE	ACTUAL FACTOR	STANDARD FACTOR	MNHR5 REQ'D
1 OBTAIN MATERIAL RECEIPT & PREP	SQ FT	0.010	78681	1	1	1.0	1.0	787
2 FLAME CUTTING								
AUTOMATIC	LN FT	0.040	45332	1	1	1.0	1.0	1796
MANUAL	LN FT	0.071	2386	2	2	1.5	1.5	170
3 EDGE PREP-GRINDING								
FLAT	LN FT	0.032	1781	1	2	1.0	1.5	56
VERTICAL	LN FT	0.048	497	2	2	1.5	1.5	24
OVERHEAD	LN FT	0.063	108	2	2	1.5	1.5	7
4 SHAPING								
BREAK	BEND	0.380	0	1	1	1.0	1.0	0
ROLLING	PIECE	0.951	4	1	1	1.0	1.0	4
LINE HEATING	PIECE	10.000	0	1	1	1.0	1.0	0
FURNACE	PIECE	15.000	0	1	1	1.0	1.0	0
PRESS	PIECE	0.019	0	1	1	1.0	1.0	0
MACHINING	CU IN	0.020	0	1	1	1.0	1.0	0
5 FIT UP & ASSEMBLY	JOINT	0.444	6264	2	2	1.5	1.5	2780
6 WELDING, AUTO/MACHINE								
FILLET	LN FT	0.052	44281	2	2	1.5	1.5	2281
BUTT	LN FT	0.3804	3157	2	2	1.5	1.5	1201
7 WELDING, MANUAL								
FILLET								
DOWNHAND	LN FT	0.269	22378	2	2	1.5	1.5	6030
VERTICAL	LN FT	0.404	6245	2	2	1.5	1.5	2524
OVERHEAD	LN FT	0.539	1356	2	2	1.5	1.5	731
BUTT								
DOWNHAND	LN FT	1.030	1595	2	2	1.5	1.5	1643
VERTICAL	LN FT	1.545	445	2	2	1.5	1.5	688
OVERHEAD	LN FT	2.061	97	2	2	1.5	1.5	199
8 MARKING	PIECE	0.100	1566	1	1	1.0	1.0	157
9 HANDLING								
STORAGE	PIECE	0.100	1566	2	2	1.5	1.5	157
TRANSPORTING	ASSY	5.000	24	3	3	2.0	2.0	120
LIFTING	ASSY	5.000	24	4	4	3.0	3.0	120
10 REWORK	JOINT	1.000	671	5	2	4.5	1.5	2013
TOTAL TRADE MANHOURS								23487
TRADE SUPPORT MANHOURS (28% OF TRADE MANHOURS)								6515
TOTAL PRODUCTION MANHOURS								30002

NSRP PANEL SP-4
 FILE: STRCTMS Revised

LABOR HOUR ESTIMATING FORM FOR STRUCTURAL WORK

40KDWT BASE ALTERNATIVE
 Entire Tank Section MATERIAL: MS-ST5
 4050 THICKNESS 0.57 INCHES

PROJECT:
 FILE :

WORK PROCESS	WORK UNITS	PROCESS FACTOR (MNHRS/ WORK UNIT)	UNIT AMOUNT	ACTUAL STAGE	STANDARD STAGE	ACTUAL FACTOR	STANDARD FACTOR	MNHRS REQ'D
1 OBTAIN MATERIAL RECEIPT & PREP	SQ FT	0.010	78445	1	1	1.0	1.0	784
2 FLAME CUTTING								
AUTOMATIC	LN FT	0.040	48307	1	1	1.0	1.0	1914
MANUAL	LN FT	0.071	2542	2	2	1.5	1.5	181
3 EDGE PREP-GRINDING								
FLAT	LN FT	0.032	2024	1	2	1.0	1.5	64
VERTICAL	LN FT	0.048	407	2	2	1.5	1.5	19
OVERHEAD	LN FT	0.063	111	2	2	1.5	1.5	7
4 SHAPING								
BREAK	BEND	0.380	0	1	1	1.0	1.0	0
ROLLING	PIECE	0.951	4	1	1	1.0	1.0	4
LINE HEATING	PIECE	10.000	0	1	1	1.0	1.0	0
FURNACE	PIECE	15.000	0	1	1	1.0	1.0	0
PRESS	PIECE	0.019	0	1	1	1.0	1.0	0
MACHINING	CU IN	0.020	0	1	1	1.0	1.0	0
5 FIT UP & ASSEMBLY	JOINT	0.444	6600	2	2	1.5	1.5	2929
6 WELDING, AUTO/MACHINE								
FILLET	LN FT	0.052	50128	2	2	1.5	1.5	2582
BUTT	LN FT	0.3804	3689	2	2	1.5	1.5	1403
7 WELDING, MANUAL								
FILLET								
DOWNHAND	LN FT	0.269	22644	2	2	1.5	1.5	6101
VERTICAL	LN FT	0.404	4557	2	2	1.5	1.5	1842
OVERHEAD	LN FT	0.539	1241	2	2	1.5	1.5	669
BUTT								
DOWNHAND	LN FT	1.030	1666	2	2	1.5	1.5	1717
VERTICAL	LN FT	1.545	335	2	2	1.5	1.5	518
OVERHEAD	LN FT	2.061	91	2	2	1.5	1.5	188
8 MARKING	PIECE	0.100	1650	1	1	1.0	1.0	165
9 HANDLING								
STORAGE	PIECE	0.100	1650	2	2	1.5	1.5	165
TRANSPORTING	ASSY	5.000	24	3	3	2.0	2.0	120
LIFTING	ASSY	5.000	24	4	4	3.0	3.0	120
10 REWORK	JOINT	1.000	671	5	2	4.5	1.5	2014

TOTAL TRADE LABORHOURS 23508
 TRADE SUPPORT LABORHOURS (28% OF TRADE LABORHOURS) 6520
 TOTAL PRODUCTION LABORHOURS 30028

NSRP PANEL SP-4
 FILE: STRCTMS Revised

LABOR HOUR ESTIMATING FORM FOR STRUCTURAL WORK
 40KDWT BASE ALTERNATIVE
 Entire Tank Section MATERIAL: MS-ST5
 4060 THICKNESS 0.58 INCHES

PROJECT:
 FILE :

WORK PROCESS	WORK UNITS	PROCESS FACTOR (MNHRS/WORK UNIT)	UNIT AMOUNT	ACTUAL STAGE	STANDARD STAGE	ACTUAL FACTOR	STANDARD FACTOR	MNHRS REQ'D
1 OBTAIN MATERIAL RECEIPT & PREP	SQ FT	0.010	77342	1	1	1.0	1.0	773
2 FLAME CUTTING								
AUTOMATIC	LN FT	0.040	48757	1	1	1.0	1.0	1932
MANUAL	LN FT	0.071	2566	2	2	1.5	1.5	183
3 EDGE PREP-GRINDING								
FLAT	LN FT	0.032	2048	1	2	1.0	1.5	65
VERTICAL	LN FT	0.048	427	2	2	1.5	1.5	20
4 OVERHEAD	LN FT	0.063	91	2	2	1.5	1.5	6
4 SHAPING								
BREAK	BEND	0.380	0	1	1	1.0	1.0	0
ROLLING	PIECE	0.951	4	1	1	1.0	1.0	4
LINE HEATING	PIECE	10.000	0	1	1	1.0	1.0	0
FURNACE	PIECE	15.000	0	1	1	1.0	1.0	0
PRESS	PIECE	0.019	0	1	1	1.0	1.0	0
MACHINING	CU IN	0.020	0	1	1	1.0	1.0	0
5 FIT UP & ASSEMBLY	JOINT	0.444	7240	2	2	1.5	1.5	3213
6 WELDING, AUTO/MACHINE								
FILLET	LN FT	0.052	49506	2	2	1.5	1.5	2550
BUTT	LN FT	0.3804	3335	2	2	1.5	1.5	1269
7 WELDING, MANUAL								
FILLET								
DOWNHAND	LN FT	0.269	25017	2	2	1.5	1.5	6741
VERTICAL	LN FT	0.404	5222	2	2	1.5	1.5	2111
OVERHEAD	LN FT	0.539	1112	2	2	1.5	1.5	599
BUTT								
DOWNHAND	LN FT	1.030	1685	2	2	1.5	1.5	1736
VERTICAL	LN FT	1.545	352	2	2	1.5	1.5	544
OVERHEAD	LN FT	2.061	75	2	2	1.5	1.5	154
8 MARKING	PIECE	0.100	1810	1	1	1.0	1.0	181
9 HANDLING								
STORAGE	PIECE	0.100	1810	2	2	1.5	1.5	181
TRANSPORTING	ASSY	5.000	24	3	3	2.0	2.0	120
LIFTING	ASSY	5.000	24	4	4	3.0	3.0	120
10 REWORK	JOINT	1.000	704	5	2	4.5	1.5	2112
TOTAL TRADE LABORHOURS								24615
TRADE SUPPORT LABORHOURS (28% OF TRADE LABORHOURS)								6828
TOTAL PRODUCTION LABORHOURS								31442

LABOR HOUR ESTIMATING FORM FOR STRUCTURAL WORK
 40KDWT BASE ALTERNATIVE
 Entire Tank Section MATERIAL: MS-ST5
 4070 THICKNESS 0.62 INCHES

PROJECT:
 FILE :

WORK PROCESS	WORK UNITS	PROCESS FACTOR (MNHRS/ WORK UNIT)	UNIT AMOUNT	ACTUAL STAGE	STANDARD STAGE	ACTUAL FACTOR	STANDARD FACTOR	MNHRS REQ'D
1 OBTAIN MATERIAL RECEIPT & PREP	SQ FT	0.010	73232	1	1	1.0	1.0	732
2 FLAME CUTTING								
AUTOMATIC	LN FT	0.040	36878	1	1	1.0	1.0	1461
MANUAL	LN FT	0.071	1941	2	2	1.5	1.5	138
3 EDGE PREP-GRINDING								
FLAT	LN FT	0.032	1458	1	2	1.0	1.5	46
VERTICAL	LN FT	0.048	389	2	2	1.5	1.5	18
OVERHEAD	LN FT	0.063	94	2	2	1.5	1.5	6
4 SHAPING								
BREAK	BEND	0.380	0	1	1	1.0	1.0	0
ROLLING	PIECE	0.951	4	1	1	1.0	1.0	4
LINE HEATING	PIECE	10.000	0	1	1	1.0	1.0	0
FURNACE	PIECE	15.000	0	1	1	1.0	1.0	0
PRESS	PIECE	0.019	0	1	1	1.0	1.0	0
MACHINING	CU IN	0.020	0	1	1	1.0	1.0	0
5 FIT UP & ASSEMBLY	JOINT	0.444	6568	2	2	1.5	1.5	2915
6 WELDING, AUTO/MACHINE								
FILLET	LN FT	0.052	30339	2	2	1.5	1.5	1563
BUTT	LN FT	0.3804	3046	2	2	1.5	1.5	1159
7 WELDING, MANUAL								
FILLET								
DOWNHAND	LN FT	0.269	18826	2	2	1.5	1.5	5073
VERTICAL	LN FT	0.404	5018	2	2	1.5	1.5	2028
OVERHEAD	LN FT	0.539	1212	2	2	1.5	1.5	653
BUTT								
DOWNHAND	LN FT	1.030	1890	2	2	1.5	1.5	1947
VERTICAL	LN FT	1.545	504	2	2	1.5	1.5	779
OVERHEAD	LN FT	2.061	122	2	2	1.5	1.5	251
8 MARKING	PIECE	0.100	1642	1	1	1.0	1.0	164
9 HANDLING								
STORAGE	PIECE	0.100	1642	2	2	1.5	1.5	164
TRANSPORTING	ASSY	5.000	24	3	3	2.0	2.0	120
LIFTING	ASSY	5.000	24	4	4	3.0	3.0	120
10 REWORK	JOINT	1.000	601	5	2	4.5	1.5	1804
TOTAL TRADE LABORHOURS								21145
TRADE SUPPORT LABORHOURS (28% OF TRADE LABORHOURS)								5865
TOTAL PRODUCTION LABORHOURS								27010

NSRP PANEL SP-4
 FILE: STRCTMS Revised

LABOR HOUR ESTIMATING FORM FOR STRUCTURAL WORK
 40KDWT BASE ALTERNATIVE
 Entire Tank Section MATERIAL: MS-ST5
 4080 THICKNESS 0.58 INCHES

WORK PROCESS	WORK UNITS	PROCESS FACTOR (MNHRS/WORK UNIT)	UNIT AMOUNT	ACTUAL STAGE	STANDARD STAGE	ACTUAL FACTOR	STANDARD FACTOR	MNHRS REQ'D
1 OBTAIN MATERIAL RECEIPT & PREP	SQ FT	0.010	78445	1	1	1.0	1.0	784
2 FLAME CUTTING								
AUTOMATIC	LN FT	0.040	30774	1	1	1.0	1.0	1219
MANUAL	LN FT	0.071	1620	2	2	1.5	1.5	116
3 EDGE PREP-GRINDING								
FLAT	LN FT	0.032	1123	1	2	1.0	1.5	36
VERTICAL	LN FT	0.048	401	2	2	1.5	1.5	19
OVERHEAD	LN FT	0.063	95	2	2	1.5	1.5	6
4 SHAPING								
BREAK	BEND	0.380	7657	1	1	1.0	1.0	2913
ROLLING	PIECE	0.951	4	1	1	1.0	1.0	4
LINE HEATING	PIECE	10.000	0	1	1	1.0	1.0	0
FURNACE	PIECE	15.000	0	1	1	1.0	1.0	0
PRESS	PIECE	0.019	0	1	1	1.0	1.0	0
MACHINING	CU IN	0.020	0	1	1	1.0	1.0	0
5 FIT UP & ASSEMBLY	JOINT	0.444	6120	2	2	1.5	1.5	2716
6 WELDING, AUTO/MACHINE								
FILLET	LN FT	0.052	14720	2	2	1.5	1.5	758
BUTT	LN FT	0.3804	4200	2	2	1.5	1.5	1598
7 WELDING, MANUAL								
FILLET								
DOWNHAND	LN FT	0.269	10819	2	2	1.5	1.5	2915
VERTICAL	LN FT	0.404	3865	2	2	1.5	1.5	1562
OVERHEAD	LN FT	0.539	918	2	2	1.5	1.5	495
BUTT								
DOWNHAND	LN FT	1.030	3087	2	2	1.5	1.5	3180
VERTICAL	LN FT	1.545	1103	2	2	1.5	1.5	1704
OVERHEAD	LN FT	2.061	262	2	2	1.5	1.5	540
8 MARKING	PIECE	0.100	1530	1	1	1.0	1.0	153
9 HANDLING								
STORAGE	PIECE	0.100	1530	2	2	1.5	1.5	153
TRANSPORTING	ASSY	5.000	24	3	3	2.0	2.0	120
LIFTING	ASSY	5.000	24	4	4	3.0	3.0	120
10 REWORK	JOINT	1.000	562	5	2	4.5	1.5	1686
TOTAL TRADE LABORHOURS								22796
TRADE SUPPORT LABORHOURS (28% OF TRADE LABORHOURS)								6323
TOTAL PRODUCTION LABORHOURS								29120

NSRP PANEL SP-4
 FILE: STRCTMS Revised

LABOR HOUR ESTIMATING FORM FOR STRUCTURAL WORK

40KDWT BASE ALTERNATIVE

PROJECT:
 FILE :

Entire Tank Section MATERIAL: MS-ST5
 4090 THICKNESS 0.57 INCHES

WORK PROCESS	WORK UNITS	PROCESS FACTOR (MNHRS/ WORK UNIT)	UNIT AMOUNT	ACTUAL STAGE	STANDARD STAGE	ACTUAL FACTOR	STANDARD FACTOR	MNHRS REQ'D
1 OBTAIN MATERIAL RECEIPT & PREP	SQ FT	0.010	79149	1	1	1.0	1.0	791
2 FLAME CUTTING								
AUTOMATIC	LN FT	0.040	47582	1	1	1.0	1.0	1885
MANUAL	LN FT	0.071	2504	2	2	1.5	1.5	179
3 EDGE PREP-GRINDING								
FLAT	LN FT	0.032	1990	1	2	1.0	1.5	63
VERTICAL	LN FT	0.048	407	2	2	1.5	1.5	19
OVERHEAD	LN FT	0.063	108	2	2	1.5	1.5	7
4 SHAPING								
BREAK	BEND	0.380	0	1	1	1.0	1.0	0
ROLLING	PIECE	0.951	4	1	1	1.0	1.0	4
LINE HEATING	PIECE	10.000	0	1	1	1.0	1.0	0
FURNACE	PIECE	15.000	0	1	1	1.0	1.0	0
PRESS	PIECE	0.019	0	1	1	1.0	1.0	0
MACHINING	CU IN	0.020	0	1	1	1.0	1.0	0
5 FIT UP & ASSEMBLY	JOINT	0.444	6568	2	2	1.5	1.5	2915
6 WELDING, AUTO/MACHINE								
FILLET	LN FT	0.052	58054	2	2	1.5	1.5	2991
BUTT	LN FT	0.3804	4143	2	2	1.5	1.5	1576
7 WELDING, MANUAL								
FILLET								
DOWNHAND	LN FT	0.269	15788	2	2	1.5	1.5	4254
VERTICAL	LN FT	0.404	3228	2	2	1.5	1.5	1305
OVERHEAD	LN FT	0.539	856	2	2	1.5	1.5	462
BUTT								
DOWNHAND	LN FT	1.030	1127	2	2	1.5	1.5	1161
VERTICAL	LN FT	1.545	230	2	2	1.5	1.5	356
OVERHEAD	LN FT	2.061	61	2	2	1.5	1.5	126
8 MARKING	PIECE	0.100	1642	1	1	1.0	1.0	164
9 HANDLING								
STORAGE	PIECE	0.100	1642	2	2	1.5	1.5	164
TRANSPORTING	ASSY	5.000	24	3	3	2.0	2.0	120
LIFTING	ASSY	5.000	24	4	4	3.0	3.0	120
10 REWORK	JOINT	1.000	577	5	2	4.5	1.5	1730
TOTAL TRADE LABORHOURS								20392
TRADE SUPPORT LABORHOURS (28% OF TRADE LABORHOURS)								5656
TOTAL PRODUCTION LABORHOURS								26048

NSRP PANEL SP-4
 FILE: STRCTMS Revised

LABOR HOUR ESTIMATING FORM FOR STRUCTURAL WORK
 40KDWT BASE ALTERNATIVE
 Entire Tank Section MATERIAL: MS-ST5
 40100 THICKNESS 0.81 INCHES

WORK PROCESS	WORK UNITS	PROCESS FACTOR (MNHRS/WORK UNIT)	UNIT AMOUNT	ACTUAL STAGE	STANDARD STAGE	ACTUAL FACTOR	STANDARD FACTOR	MNHRS REQ'D
1 OBTAIN MATERIAL RECEIPT & PREP	SQ FT	0.010	96568	1	1	1.0	1.0	966
2 FLAME CUTTING								
AUTOMATIC	LN FT	0.055	29504	1	1	1.0	1.0	1637
MANUAL	LN FT	0.095	1553	2	2	1.5	1.5	148
3 EDGE PREP-GRINDING								
FLAT	LN FT	0.048	1028	1	2	1.0	1.5	49
VERTICAL	LN FT	0.095	377	2	2	1.5	1.5	36
OVERHEAD	LN FT	0.135	148	2	2	1.5	1.5	20
4 SHAPING								
BREAK	BEND	0.380	0	1	1	1.0	1.0	0
ROLLING	PIECE	0.951	4	1	1	1.0	1.0	4
LINE HEATING	PIECE	10.000	0	1	1	1.0	1.0	0
FURNACE	PIECE	15.000	0	1	1	1.0	1.0	0
PRESS	PIECE	0.019	0	1	1	1.0	1.0	0
MACHINING	CU IN	0.020	0	1	1	1.0	1.0	0
5 FIT UP & ASSEMBLY	JOINT	0.444	5440	2	2	1.5	1.5	2414
6 WELDING, AUTO/MACHINE								
FILLET	LN FT	0.062	16183	2	2	1.5	1.5	1000
BUTT	LN FT	0.45965	2810	2	2	1.5	1.5	1292
WELDING, MANUAL								
FILLET								
DOWNHAND	LN FT	0.476	13556	2	2	1.5	1.5	6446
VERTICAL	LN FT	0.951	4968	2	2	1.5	1.5	4724
OVERHEAD	LN FT	1.347	1949	2	2	1.5	1.5	2625
BUTT								
DOWNHAND	LN FT	1.427	2354	2	2	1.5	1.5	3358
VERTICAL	LN FT	2.853	863	2	2	1.5	1.5	2461
OVERHEAD	LN FT	4.042	338	2	2	1.5	1.5	1367
8 MARKING	PIECE	0.100	1360	1	1	1.0	1.0	136
9 HANDLING								
STORAGE	PIECE	0.100	1360	2	2	1.5	1.5	136
TRANSPORTING	ASSY	5.000	24	3	3	2.0	2.0	120
LIFTING	ASSY	5.000	24	4	4	3.0	3.0	120
10 REWORK	JOINT	1.000	919	5	2	4.5	1.5	2758
TOTAL TRADE LABORHOURS								31816
TRADE SUPPORT LABORHOURS (28% OF TRADE LABORHOURS)								8825
TOTAL PRODUCTION LABORHOURS								40641

NSRP PANEL SP-4
 FILE: STRCTMS Revised

LABOR HOUR ESTIMATING FORM FOR STRUCTURAL WORK
 40KDWT BASE ALTERNATIVE
 Entire Tank Section MATERIAL: MS-ST5
 40110 THICKNESS 0.7 INCHES

WORK PROCESS	WORK UNITS	PROCESS FACTOR (MNHRS/WORK UNIT)	UNIT AMOUNT	ACTUAL STAGE	STANDARD STAGE	ACTUAL FACTOR	STANDARD FACTOR	MNHR5 REQ'D
1 OBTAIN MATERIAL RECEIPT & PREP	SQ FT	0.010	89244	1	1	1.0	1.0	892
2 FLAME CUTTING								
AUTOMATIC	LN FT	0.040	30637	1	1	1.0	1.0	1214
MANUAL	LN FT	0.071	1612	2	2	1.5	1.5	115
3 EDGE PREP-GRINDING								
FLAT	LN FT	0.032	1085	1	2	1.0	1.5	34
VERTICAL	LN FT	0.048	369	2	2	1.5	1.5	18
OVERHEAD	LN FT	0.063	158	2	2	1.5	1.5	10
4 SHAPING								
BREAK	BEND	0.380	0	1	1	1.0	1.0	0
ROLLING	PIECE	0.951	4	1	1	1.0	1.0	4
LINE HEATING	PIECE	10.000	0	1	1	1.0	1.0	0
FURNACE	PIECE	15.000	0	1	1	1.0	1.0	0
PRESS	PIECE	0.019	0	1	1	1.0	1.0	0
MACHINING	CU IN	0.020	0	1	1	1.0	1.0	0
5 FIT UP & ASSEMBLY	JOINT	0.444	3968	2	2	1.5	1.5	1761
6 WELDING, AUTO/MACHINE								
FILLET	LN FT	0.052	16995	2	2	1.5	1.5	875
BUTT	LN FT	0.3804	3165	2	2	1.5	1.5	1204
7 WELDING, MANUAL								
FILLET								
DOWNHAND	LN FT	0.269	13440	2	2	1.5	1.5	3621
VERTICAL	LN FT	0.404	4567	2	2	1.5	1.5	1846
OVERHEAD	LN FT	0.539	1960	2	2	1.5	1.5	1056
BUTT								
DOWNHAND	LN FT	1.030	2503	2	2	1.5	1.5	2579
VERTICAL	LN FT	1.545	851	2	2	1.5	1.5	1314
OVERHEAD	LN FT	2.061	365	2	2	1.5	1.5	752
8 MARKING	PIECE	0.100	992	1	1	1.0	1.0	99
9 HANDLING								
STORAGE	PIECE	0.100	992	2	2	1.5	1.5	99
TRANSPORTING	ASSY	5.000	24	3	3	2.0	2.0	120
LIFTING	ASSY	5.000	24	4	4	3.0	3.0	120
10 REWORK	JOINT	1.000	547	5	2	4.5	1.5	1640
TOTAL TRADE LABORHOURS								19375
TRADE SUPPORT LABORHOURS (28% OF TRADE LABORHOURS)								5374
TOTAL PRODUCTION LABORHOURS								24750

NSRP PANEL SP-4
 FILE: STRCTMS Revised

LABOR HOUR ESTIMATING FORM FOR STRUCTURAL WORK
 40KDWT BASE ALTERNATIVE

PROJECT: Entire Tank Section MATERIAL: MS-STs
 FILE: 40111 THICKNESS 0.7 INCHES

WORK PROCESS	WORK UNITS	PROCESS FACTOR (MNHRS/WORK UNIT)	UNIT AMOUNT	ACTUAL STAGE	STANDARD STAGE	ACTUAL FACTOR	STANDARD FACTOR	MNHRs REQ'D
1 OBTAIN MATERIAL RECEIPT & PREP	SQ FT	0.010	92543	1	1	1.0	1.0	925
2 FLAME CUTTING								
AUTOMATIC	LN FT	0.040	32005	1	1	1.0	1.0	1268
MANUAL	LN FT	0.071	1684	2	2	1.5	1.5	120
3 EDGE PREP-GRINDING								
FLAT	LN FT	0.032	1146	1	2	1.0	1.5	36
VERTICAL	LN FT	0.048	381	2	2	1.5	1.5	18
OVERHEAD	LN FT	0.063	158	2	2	1.5	1.5	10
4 SHAPING								
BREAK	BEND	0.380	0	1	1	1.0	1.0	0
ROLLING	PIECE	0.951	4	1	1	1.0	1.0	4
LINE HEATING	PIECE	10.000	0	1	1	1.0	1.0	0
FURNACE	PIECE	15.000	0	1	1	1.0	1.0	0
PRESS	PIECE	0.019	0	1	1	1.0	1.0	0
MACHINING	CU IN	0.020	0	1	1	1.0	1.0	0
5 FIT UP & ASSEMBLY	JOINT	0.444	3992	2	2	1.5	1.5	1772
6 WELDING, AUTO/MACHINE								
FILLET	LN FT	0.052	17837	2	2	1.5	1.5	919
BUTT	LN FT	0.3804	3400	2	2	1.5	1.5	1293
7 WELDING, MANUAL								
FILLET								
DOWNHAND	LN FT	0.269	13869	2	2	1.5	1.5	3737
VERTICAL	LN FT	0.404	4608	2	2	1.5	1.5	1863
OVERHEAD	LN FT	0.539	1917	2	2	1.5	1.5	1033
BUTT								
DOWNHAND	LN FT	1.030	2644	2	2	1.5	1.5	2723
VERTICAL	LN FT	1.545	878	2	2	1.5	1.5	1357
OVERHEAD	LN FT	2.061	365	2	2	1.5	1.5	753
8 MARKING	PIECE	0.100	998	1	1	1.0	1.0	100
9 HANDLING								
STORAGE	PIECE	0.100	998	2	2	1.5	1.5	100
TRANSPORTING	ASSY	5.000	24	3	3	2.0	2.0	120
LIFTING	ASSY	5.000	24	4	4	3.0	3.0	120
10 REWORK	JOINT	1.000	563	5	2	4.5	1.5	1690
TOTAL TRADE LABORHOURS								19961
TRADE SUPPORT LABORHOURS (28% OF TRADE LABORHOURS)								5537
TOTAL PRODUCTION LABORHOURS								25498

NSRP PANEL SP-4
 FILE: STRCTMS Revised

LABOR HOUR ESTIMATING FORM FOR STRUCTURAL WORK
 40KDWT BASE ALTERNATIVE

PROJECT: Entire Tank Section MATERIAL: MS-ST5
 FILE : 40112 THICKNESS 0.69 INCHES

WORK PROCESS	WORK UNITS	PROCESS FACTOR (MNHRS/ WORK UNIT)	UNIT AMOUNT	ACTUAL STAGE	STANDARD STAGE	ACTUAL FACTOR	STANDARD FACTOR	MNHRS REQ'D
1 OBTAIN MATERIAL RECEIPT & PREP	SQ FT	0.010	76283	1	1	1.0	1.0	763
2 FLAME CUTTING								
AUTOMATIC	LN FT	0.040	26705	1	1	1.0	1.0	1058
MANUAL	LN FT	0.071	1406	2	2	1.5	1.5	100
3 EDGE PREP-GRINDING								
FLAT	LN FT	0.032	931	1	2	1.0	1.5	30
VERTICAL	LN FT	0.048	317	2	2	1.5	1.5	15
OVERHEAD	LN FT	0.063	158	2	2	1.5	1.5	10
4 SHAPING								
BREAK	BEND	0.380	0	1	1	1.0	1.0	0
ROLLING	PIECE	0.951	4	1	1	1.0	1.0	4
LINE HEATING	PIECE	10.000	0	1	1	1.0	1.0	0
FURNACE	PIECE	15.000	0	1	1	1.0	1.0	0
PRESS	PIECE	0.019	0	1	1	1.0	1.0	0
MACHINING	CU IN	0.020	0	1	1	1.0	1.0	0
5 FIT UP & ASSEMBLY	JOINT	0.444	3416	2	2	1.5	1.5	1516
6 WELDING, AUTO/MACHINE								
FILLET	LN FT	0.052	12888	2	2	1.5	1.5	664
BUTT	LN FT	0.3804	2971	2	2	1.5	1.5	1130
7 WELDING, MANUAL								
FILLET								
DOWNHAND	LN FT	0.269	10835	2	2	1.5	1.5	2919
VERTICAL	LN FT	0.404	3686	2	2	1.5	1.5	1490
OVERHEAD	LN FT	0.539	1843	2	2	1.5	1.5	993
BUTT								
DOWNHAND	LN FT	1.030	2497	2	2	1.5	1.5	2573
VERTICAL	LN FT	1.545	850	2	2	1.5	1.5	1313
OVERHEAD	LN FT	2.061	425	2	2	1.5	1.5	875
8 MARKING	PIECE	0.100	854	1	1	1.0	1.0	85
9 HANDLING								
STORAGE	PIECE	0.100	854	2	2	1.5	1.5	85
TRANSPORTING	ASSY	5.000	24	3	3	2.0	2.0	120
LIFTING	ASSY	5.000	24	4	4	3.0	3.0	120
10 REWORK	JOINT	1.000	490	5	2	4.5	1.5	1469
TOTAL TRADE LABORHOURS								17332
TRADE SUPPORT LABORHOURS (28% OF TRADE LABORHOURS)								4808
TOTAL PRODUCTION LABORHOURS								22140

NSRP PANEL SP-4
 FILE: STRCTMS Revised

LABOR HOUR ESTIMATING FORM FOR STRUCTURAL WORK

40KDWT BASE ALTERNATIVE

PROJECT: Entire Tank Section MATERIAL: MS-ST5
 FILE: 40120 THICKNESS 0.84 INCHES

WORK PROCESS	WORK UNITS	PROCESS FACTOR (MNHRS/WORK UNIT)	UNIT AMOUNT	ACTUAL STAGE	STANDARD STAGE	ACTUAL FACTOR	STANDARD FACTOR	MNHRS REQ'D
1 OBTAIN MATERIAL RECEIPT & PREP	SQ FT	0.010	87781	1	1	1.0	1.0	878
2 FLAME CUTTING								
AUTOMATIC	LN FT	0.055	43028	1	1	1.0	1.0	2387
MANUAL	LN FT	0.095	2265	2	2	1.5	1.5	215
3 EDGE PREP-GRINDING								
FLAT	LN FT	0.048	1198	1	2	1.0	1.5	57
VERTICAL	LN FT	0.095	981	2	2	1.5	1.5	93
OVERHEAD	LN FT	0.135	85	2	2	1.5	1.5	11
4 SHAPING								
BREAK	BEND	0.380	0	1	1	1.0	1.0	0
ROLLING	PIECE	0.951	4	1	1	1.0	1.0	4
LINE HEATING	PIECE	10.000	0	1	1	1.0	1.0	0
FURNACE	PIECE	15.000	0	1	1	1.0	1.0	0
PRESS	PIECE	0.019	0	1	1	1.0	1.0	0
MACHINING	CU IN	0.020	0	1	1	1.0	1.0	0
5 FIT UP & ASSEMBLY	JOINT	0.444	8464	2	2	1.5	1.5	3756
6 WELDING, AUTO/MACHINE								
FILLET	LN FT	0.062	27667	2	2	1.5	1.5	1710
BUTT	LN FT	0.45965	3632	2	2	1.5	1.5	1669
7 WELDING, MANUAL								
FILLET								
DOWNHAND	LN FT	0.476	12174	2	2	1.5	1.5	5789
VERTICAL	LN FT	0.951	9971	2	2	1.5	1.5	9483
OVERHEAD	LN FT	1.347	862	2	2	1.5	1.5	1161
BUTT								
DOWNHAND	LN FT	1.427	1598	2	2	1.5	1.5	2280
VERTICAL	LN FT	2.853	1309	2	2	1.5	1.5	3734
OVERHEAD	LN FT	4.042	113	2	2	1.5	1.5	457
8 MARKING	PIECE	0.100	2116	1	1	1.0	1.0	212
9 HANDLING								
STORAGE	PIECE	0.100	2116	2	2	1.5	1.5	212
TRANSPORTING	ASSY	5.000	24	3	3	2.0	2.0	120
LIFTING	ASSY	5.000	24	4	4	3.0	3.0	120
10 REWORK	JOINT	1.000	1093	5	2	4.5	1.5	3280
TOTAL TRADE LABORHOURS								37629
TRADE SUPPORT LABORHOURS (28% OF TRADE LABORHOURS)								10437
TOTAL PRODUCTION LABORHOURS								48067

NSRP PANEL SP-4
 FILE: STRCTMS Revised

LABOR HOUR ESTIMATING FORM FOR STRUCTURAL WORK
 40KDWT BASE ALTERNATIVE
 PROJECT: Entire Tank Section MATERIAL: MS-ST5
 FILE: 40121 THICKNESS 0.84 INCHES

WORK PROCESS	WORK UNITS	PROCESS FACTOR (MNHRS/WORK UNIT)	UNIT AMOUNT	ACTUAL STAGE	STANDARD STAGE	ACTUAL FACTOR	STANDARD FACTOR	MNHRS REQ'D
1 OBTAIN MATERIAL RECEIPT & PREP	SQ FT	0.010	87781	1	1	1.0	1.0	878
2 FLAME CUTTING								
AUTOMATIC	LN FT	0.055	42117	1	1	1.0	1.0	2336
MANUAL	LN FT	0.095	2217	2	2	1.5	1.5	211
3 EDGE PREP-GRINDING								
FLAT	LN FT	0.048	1872	1	2	1.0	1.5	89
VERTICAL	LN FT	0.095	260	2	2	1.5	1.5	25
OVERHEAD	LN FT	0.135	85	2	2	1.5	1.5	11
4 SHAPING								
BREAK	BEND	0.380	0	1	1	1.0	1.0	0
ROLLING	PIECE	0.951	4	1	1	1.0	1.0	4
LINE HEATING	PIECE	10.000	0	1	1	1.0	1.0	0
FURNACE	PIECE	15.000	0	1	1	1.0	1.0	0
PRESS	PIECE	0.019	0	1	1	1.0	1.0	0
MACHINING	CU IN	0.020	0	1	1	1.0	1.0	0
5 FIT UP & ASSEMBLY	JOINT	0.444	8464	2	2	1.5	1.5	3756
6 WELDING, AUTO/MACHINE								
FILLET	LN FT	0.062	38398	2	2	1.5	1.5	2374
BUTT	LN FT	0.45965	5239	2	2	1.5	1.5	2408
7 WELDING, MANUAL								
FILLET								
DOWNHAND	LN FT	0.476	8747	2	2	1.5	1.5	4159
VERTICAL	LN FT	0.951	1215	2	2	1.5	1.5	1156
OVERHEAD	LN FT	1.347	397	2	2	1.5	1.5	534
BUTT								
DOWNHAND	LN FT	1.427	1193	2	2	1.5	1.5	1702
VERTICAL	LN FT	2.853	166	2	2	1.5	1.5	473
OVERHEAD	LN FT	4.042	54	2	2	1.5	1.5	219
8 MARKING	PIECE	0.100	2116	1	1	1.0	1.0	212
9 HANDLING								
STORAGE	PIECE	0.100	2116	2	2	1.5	1.5	212
TRANSPORTING	ASSY	5.000	24	3	3	2.0	2.0	120
LIFTING	ASSY	5.000	24	4	4	3.0	3.0	120
10 REWORK	JOINT	1.000	648	5	2	4.5	1.5	1945
TOTAL TRADE LABORHOURS								22943
TRADE SUPPORT LABORHOURS (28% OF TRADE LABORHOURS)								6364
TOTAL PRODUCTION LABORHOURS								29307

NSRP PANEL SP-4
 FILE: STRCTMS Revised

LABOR HOUR ESTIMATING FORM FOR STRUCTURAL WORK
 40KDWT BASE ALTERNATIVE
 PROJECT: Entire Tank Section MATERIAL: MS-ST5
 FILE: 40130 THICKNESS 0.57 INCHES

WORK PROCESS	WORK UNITS	PROCESS FACTOR (MNHRS/WORK UNIT)	UNIT AMOUNT	ACTUAL STAGE	STANDARD STAGE	ACTUAL FACTOR	STANDARD FACTOR	MNHR5 REQ'D
1 OBTAIN MATERIAL RECEIPT & PREP	SQ FT	0.010	79149	1	1	1.0	1.0	791
2 FLAME CUTTING								
AUTOMATIC	LN FT	0.040	47582	1	1	1.0	1.0	1885
MANUAL	LN FT	0.071	2504	2	2	1.5	1.5	179
3 EDGE PREP-GRINDING								
FLAT	LN FT	0.032	1990	1	2	1.0	1.5	63
VERTICAL	LN FT	0.048	407	2	2	1.5	1.5	19
OVERHEAD	LN FT	0.063	108	2	2	1.5	1.5	7
4 SHAPING								
BREAK	BEND	0.380	0	1	1	1.0	1.0	0
ROLLING	PIECE	0.951	4	1	1	1.0	1.0	4
LINE HEATING	PIECE	10.000	0	1	1	1.0	1.0	0
FURNACE	PIECE	15.000	0	1	1	1.0	1.0	0
PRESS	PIECE	0.019	0	1	1	1.0	1.0	0
MACHINING	CU IN	0.020	0	1	1	1.0	1.0	0
5 FIT UP & ASSEMBLY	JOINT	0.444	6568	2	2	1.5	1.5	2915
6 WELDING, AUTO/MACHINE								
FILLET	LN FT	0.052	49968	2	2	1.5	1.5	2574
BUTT	LN FT	0.3804	3530	2	2	1.5	1.5	1343
7 WELDING, MANUAL								
FILLET								
DOWNHAND	LN FT	0.269	22352	2	2	1.5	1.5	6023
VERTICAL	LN FT	0.404	4571	2	2	1.5	1.5	1847
OVERHEAD	LN FT	0.539	1213	2	2	1.5	1.5	653
BUTT								
DOWNHAND	LN FT	1.030	1579	2	2	1.5	1.5	1627
VERTICAL	LN FT	1.545	323	2	2	1.5	1.5	499
OVERHEAD	LN FT	2.061	86	2	2	1.5	1.5	177
8 MARKING	PIECE	0.100	1642	1	1	1.0	1.0	164
9 HANDLING								
STORAGE	PIECE	0.100	1642	2	2	1.5	1.5	164
TRANSPORTING	ASSY	5.000	24	3	3	2.0	2.0	120
LIFTING	ASSY	5.000	24	4	4	3.0	3.0	120
10 REWORK	JOINT	1.000	660	5	2	4.5	1.5	1981
TOTAL TRADE LABORHOURS								23156
TRADE SUPPORT LABORHOURS (28% OF TRADE LABORHOURS)								6423
TOTAL PRODUCTION LABORHOURS								29578

NSRP PANEL SP-4
 FILE: STRCTMS Revised

LABOR HOUR ESTIMATING FORM FOR STRUCTURAL WORK
 40KDWT BASE ALTERNATIVE

PROJECT: Entire Tank Section MATERIAL: MS-ST5
 FILE: 40140 THICKNESS 0.57 INCHES

WORK PROCESS	WORK UNITS	PROCESS FACTOR (MNHRS/ WORK UNIT)	UNIT AMOUNT	ACTUAL STAGE	STANDARD STAGE	ACTUAL FACTOR	STANDARD FACTOR	MNHRS REQ'D X 0.5
1 OBTAIN MATERIAL RECEIPT & PREP	SQ FT	0.010	79149	1	1	1.0	1.0	396
2 FLAME CUTTING								
AUTOMATIC	LN FT	0.040	47582	1	1	1.0	1.0	943
MANUAL	LN FT	0.071	2504	2	2	1.5	1.5	89
3 EDGE PREP-GRINDING								
FLAT	LN FT	0.032	1990	1	2	1.0	1.5	32
VERTICAL	LN FT	0.048	407	2	2	1.5	1.5	10
OVERHEAD	LN FT	0.063	108	2	2	1.5	1.5	3
4 SHAPING								
BREAK	BEND	0.380	0	1	1	1.0	1.0	0
ROLLING	PIECE	0.951	4	1	1	1.0	1.0	2
LINE HEATING	PIECE	10.000	0	1	1	1.0	1.0	0
FURNACE	PIECE	15.000	0	1	1	1.0	1.0	0
PRESS	PIECE	0.019	0	1	1	1.0	1.0	0
MACHINING	CU IN	0.020	0	1	1	1.0	1.0	0
5 FIT UP & ASSEMBLY	JOINT	0.444	6568	2	2	1.5	1.5	1457
6 WELDING, AUTO/MACHINE								
FILLET	LN FT	0.052	49968	2	2	1.5	1.5	1287
BUTT	LN FT	0.3804	3530	2	2	1.5	1.5	671
7 WELDING, MANUAL								
FILLET								
DOWNHAND	LN FT	0.269	22352	2	2	1.5	1.5	3011
VERTICAL	LN FT	0.404	4571	2	2	1.5	1.5	924
OVERHEAD	LN FT	0.539	1213	2	2	1.5	1.5	327
BUTT								
DOWNHAND	LN FT	1.030	1579	2	2	1.5	1.5	813
VERTICAL	LN FT	1.545	323	2	2	1.5	1.5	250
OVERHEAD	LN FT	2.061	86	2	2	1.5	1.5	88
8 MARKING	PIECE	0.100	1642	1	1	1.0	1.0	82
9 HANDLING								
STORAGE	PIECE	0.100	1642	2	2	1.5	1.5	82
TRANSPORTING	ASSY	5.000	24	3	3	2.0	2.0	60
LIFTING	ASSY	5.000	24	4	4	3.0	3.0	60
10 REWORK	JOINT	1.000	165	5	2	4.5	1.5	495
TOTAL TRADE LABORHOURS								11083
TRADE SUPPORT LABORHOURS (28% OF TRADE LABORHOURS)								1537
TOTAL PRODUCTION LABORHOURS								12620

NSRP !
 FILE: STRCTMS Revised

LABOR HOUR ESTIMATING FORM FOR STRUCTURAL WORK
 40KDWT BASE ALTERNATIVE
 Entire Tank MATERIAL: MS-STC
 40150 THICKNESS 0.57 INCHES

WORK PROCESS	WORK UNITS	PROCESS FACTOR (MNHRS/WORK UNIT)	UNIT AMOUNT	ACTUAL STAGE	STANDARD STAGE	ACTUAL FACTOR	STANDARD FACTOR	MNHR'S REQ'D
1 OBTAIN MATERIAL RECEIPT & PREP	SQ FT	0.010	79149	1	1	1.0	1.0	791
2 FLAME CUTTING								
AUTOMATIC	LN FT	0.040	47582	1	1	1.0	1.0	1885
MANUAL	LN FT	0.071	2504	2	2	1.5	1.5	179
3 EDGE PREP - GRINDING								
FLAT	LN FT	0.032	1990	1	2	1.0	1.5	63
VERTICAL	LN FT	0.048	407	2	2	1.5	1.5	19
OVERHEAD	LN FT	0.063	108	2	2	1.5	1.5	7
4 SHAPING								
BREAK	BEND	0.380		1	1	1.0	1.0	
ROLLING	PIECE	0.951	4	1	1	1.0	1.0	4
LINE HEATING	PIECE	10.000		1	1	1.0	1.0	
FURNACE	PIECE	15.000		1	1	1.0	1.0	
PRESS	PIECE	0.019		1	1	1.0	1.0	
MACHINING	CU IN	0.020		1	1	1.0	1.0	
5 FIT UP & ASSEMBLY	JOINT	0.444	6568	2	2	1.5	1.5	2915
6 WELDING, AUTO/MACHIN								
FILLET	LN FT	0.052	49968	2	2	1.5	1.5	2574
BUTT	LN FT	0.3804	3530	2	2	1.5	1.5	1343
7 WELDING, MANUAL								
FILLET								
DOWNHAND	LN FT	0.269	22352	2	2	1.5	1.5	6023
VERTICAL	LN FT	0.404	4571	2	2	1.5	1.5	1847
OVERHEAD	LN FT	0.539	1213	2	2	1.5	1.5	653
BUTT								
DOWNHAND	LN FT	1.030	1579	2	2	1.5	1.5	1627
VERTICAL	LN FT	1.545	323	2	2	1.5	1.5	499
OVERHEAD	LN FT	2.061	86	2	2	1.5	1.5	177
8 MARKING	PIECE	0.100	1642	1	1	1.0	1.0	164
9 HANDLING								
STORAGE	PIECE	0.100	1642	2	2	1.5	1.5	164
TRANSPORTING	ASSY	5.000	24	3	3	2.0	2.0	120
LIFTING	ASSY	5.000	24	4	4	3.0	3.0	120
10 REWORK	JOINT	1.000	660	5	2	4.5	1.5	1981
TOTAL TRADE LABORHOURS								23156
TRADE SUPPORT LABORHOURS (28% OF TRADE LABORHOURS)								6423
TOTAL PRODUCTION LAB								29578

**95KDWT Alternative Vessels
Estimation of Labor Hours Calculations for One Tank**

LABOR HOUR ESTIMATING FORM FOR STRUCTURAL WORK
 95KDWT BASE ALTERNATIVE
 Entire Tank Section MATERIAL: MS-ST5
 9510 THICKNESS 0.6 INCHES

WORK PROCESS	WORK UNITS	PROCESS FACTOR (MNHRS/WORK UNIT)	UNIT AMOUNT	ACTUAL STAGE	STANDARD STAGE	ACTUAL FACTOR	STANDARD FACTOR	MNHRS REQ'D
1 OBTAIN MATERIAL RECEIPT & PREP	SQ FT	0.010	132358	1	1	1.0	1.0	1324
2 FLAME CUTTING	AUTOMATIC LN FT	0.040	75044	1	1	1.0	1.0	2974
	MANUAL LN FT	0.071	3950	2	2	1.5	1.5	282
3 EDGE PREP-GRINDING	FLAT LN FT	0.032	3157	1	2	1.0	1.5	100
	VERTICAL LN FT	0.048	674	2	2	1.5	1.5	32
	OVERHEAD LN FT	0.063	119	2	2	1.5	1.5	8
4 SHAPING	BREAK BEND	0.380	0	1	1	1.0	1.0	0
	ROLLING PIECE	0.951	4	1	1	1.0	1.0	4
	LINE HEATING PIECE	10.000	0	1	1	1.0	1.0	0
	FURNACE PIECE	15.000	0	1	1	1.0	1.0	0
	PRESS PIECE	0.019	0	1	1	1.0	1.0	0
	MACHINING CU IN	0.020	0	1	1	1.0	1.0	0
5 FIT UP & ASSEMBLY	JOINT	0.444	9828	2	2	1.5	1.5	4362
6 WELDING, AUTO/MACHINE	FILLET LN FT	0.052	82561	2	2	1.5	1.5	4253
	BUTT LN FT	0.3804	6294	2	2	1.5	1.5	2394
7 WELDING, MANUAL	FILLET DOWNHAND LN FT	0.269	30775	2	2	1.5	1.5	8292
	VERTICAL LN FT	0.404	6568	2	2	1.5	1.5	2654
	OVERHEAD LN FT	0.539	1164	2	2	1.5	1.5	627
	BUTT DOWNHAND LN FT	1.030	2346	2	2	1.5	1.5	2417
	VERTICAL LN FT	1.545	501	2	2	1.5	1.5	774
	OVERHEAD LN FT	2.061	89	2	2	1.5	1.5	183
8 MARKING	PIECE	0.100	2457	1	1	1.0	1.0	246
9 HANDLING	STORAGE PIECE	0.100	2457	2	2	1.5	1.5	246
	TRANSPORTING ASSY	5.000	24	3	3	2.0	2.0	120
	LIFTING ASSY	5.000	24	4	4	3.0	3.0	120
10 REWORK	JOINT	1.000	978	5	2	4.5	1.5	2935
TOTAL TRADE LABORHOURS								34346
TRADE SUPPORT LABORHOURS (28% OF TRADE LABORHOURS)								9527
TOTAL PRODUCTION LABORHOURS								43872

LABOR HOUR ESTIMATING FORM FOR STRUCTURAL WORK

95KDWT BASE ALTERNATIVE

PROJECT: Entire Tank Section MATERIAL: MS-ST5
 FILE: 9520 THICKNESS 0.63 INCHES

WORK PROCESS	WORK UNITS	PROCESS FACTOR (MNHRS/WORK UNIT)	UNIT AMOUNT	ACTUAL STAGE	STANDARD STAGE	ACTUAL FACTOR	STANDARD FACTOR	MNHRS REQ'D
1 OBTAIN MATERIAL RECEIPT & PREP	SQ FT	0.010	134524	1	1	1.0	1.0	1345
2 FLAME CUTTING								
AUTOMATIC	LN FT	0.040	75087	1	1	1.0	1.0	2975
MANUAL	LN FT	0.071	3952	2	2	1.5	1.5	282
3 EDGE PREP-GRINDING								
FLAT	LN FT	0.032	3157	1	2	1.0	1.5	100
VERTICAL	LN FT	0.048	676	2	2	1.5	1.5	32
OVERHEAD	LN FT	0.063	119	2	2	1.5	1.5	8
4 SHAPING								
BREAK	BEND	0.380	0	1	1	1.0	1.0	0
ROLLING	PIECE	0.951	4	1	1	1.0	1.0	4
LINE HEATING	PIECE	10.000	0	1	1	1.0	1.0	0
FURNACE	PIECE	15.000	0	1	1	1.0	1.0	0
PRESS	PIECE	0.019	0	1	1	1.0	1.0	0
MACHINING	CU IN	0.020	0	1	1	1.0	1.0	0
5 FIT UP & ASSEMBLY	JOINT	0.444	9828	2	2	1.5	1.5	4362
6 WELDING, AUTO/MACHINE								
FILLET	LN FT	0.052	82262	2	2	1.5	1.5	4238
BUTT	LN FT	0.3804	6287	2	2	1.5	1.5	2392
7 WELDING, MANUAL								
FILLET								
DOWNHAND	LN FT	0.269	30996	2	2	1.5	1.5	8352
VERTICAL	LN FT	0.404	6639	2	2	1.5	1.5	2683
OVERHEAD	LN FT	0.539	1170	2	2	1.5	1.5	630
BUTT								
DOWNHAND	LN FT	1.030	2369	2	2	1.5	1.5	2441
VERTICAL	LN FT	1.545	507	2	2	1.5	1.5	784
OVERHEAD	LN FT	2.061	89	2	2	1.5	1.5	184
8 MARKING	PIECE	0.100	2457	1	1	1.0	1.0	246
9 HANDLING								
STORAGE	PIECE	0.100	2457	2	2	1.5	1.5	246
TRANSPORTING	ASSY	5.000	24	3	3	2.0	2.0	120
LIFTING	ASSY	5.000	24	4	4	3.0	3.0	120
10 REWORK	JOINT	1.000	982	5	2	4.5	1.5	2946
TOTAL TRADE LABORHOURS								34489
TRADE SUPPORT LABORHOURS (28% OF TRADE LABORHOURS)								9566
TOTAL PRODUCTION LABORHOURS								44055

LABOR HOUR ESTIMATING FORM FOR STRUCTURAL WORK
 95KDWT BASE ALTERNATIVE
 Entire Tank Section MATERIAL: MS-ST5
 9530 THICKNESS 0.65 INCHES

WORK PROCESS	WORK UNITS	PROCESS FACTOR (MNHRS/WORK UNIT)	UNIT AMOUNT	ACTUAL STAGE	STANDARD STAGE	ACTUAL FACTOR	STANDARD FACTOR	MNHRS REQ'D
1 OBTAIN MATERIAL RECEIPT & PREP	SQ FT	0.010	131254	1	1	1.0	1.0	1313
2 FLAME CUTTING								
AUTOMATIC	LN FT	0.040	75405	1	1	1.0	1.0	2988
MANUAL	LN FT	0.071	3969	2	2	1.5	1.5	283
3 EDGE PREP-GRINDING								
FLAT	LN FT	0.032	3176	1	2	1.0	1.5	101
VERTICAL	LN FT	0.048	681	2	2	1.5	1.5	32
OVERHEAD	LN FT	0.063	112	2	2	1.5	1.5	7
4 SHAPING								
BREAK	BEND	0.380	0	1	1	1.0	1.0	0
ROLLING	PIECE	0.951	4	1	1	1.0	1.0	4
LINE HEATING	PIECE	10.000	0	1	1	1.0	1.0	0
FURNACE	PIECE	15.000	0	1	1	1.0	1.0	0
PRESS	PIECE	0.019	0	1	1	1.0	1.0	0
MACHINING	CU IN	0.020	0	1	1	1.0	1.0	0
5 FIT UP & ASSEMBLY	JOINT	0.444	9828	2	2	1.5	1.5	4362
6 WELDING, AUTO/MACHINE								
FILLET	LN FT	0.052	83957	2	2	1.5	1.5	4325
BUTT	LN FT	0.3804	6351	2	2	1.5	1.5	2416
7 WELDING, MANUAL								
FILLET								
DOWNHAND	LN FT	0.269	30336	2	2	1.5	1.5	8174
VERTICAL	LN FT	0.404	6502	2	2	1.5	1.5	2628
OVERHEAD	LN FT	0.539	1075	2	2	1.5	1.5	579
BUTT								
DOWNHAND	LN FT	1.030	2295	2	2	1.5	1.5	2364
VERTICAL	LN FT	1.545	492	2	2	1.5	1.5	760
OVERHEAD	LN FT	2.061	81	2	2	1.5	1.5	168
8 MARKING	PIECE	0.100	2457	1	1	1.0	1.0	246
9 HANDLING								
STORAGE	PIECE	0.100	2457	2	2	1.5	1.5	246
TRANSPORTING	ASSY	5.000	24	3	3	2.0	2.0	120
LIFTING	ASSY	5.000	24	4	4	3.0	3.0	120
10 REWORK	JOINT	1.000	973	5	2	4.5	1.5	2919
TOTAL TRADE LABORHOURS								34153
TRADE SUPPORT LABORHOURS (28% OF TRADE LABORHOURS)								9473
TOTAL PRODUCTION LABORHOURS								43627

LABOR HOUR ESTIMATING FORM FOR STRUCTURAL WORK
 95KDWT BASE ALTERNATIVE

PROJECT: Entire Tank Section MATERIAL: MS-ST5
 FILE: 9540 THICKNESS 0.6 INCHES

WORK PROCESS	WORK UNITS	PROCESS FACTOR (MNHRS/ WORK UNIT)	UNIT AMOUNT	ACTUAL STAGE	STANDARD STAGE	ACTUAL FACTOR	STANDARD FACTOR	MNHRS REQ'D
1 OBTAIN MATERIAL RECEIPT & PREP	SQ FT	0.010	133089	1	1	1.0	1.0	1331
2 FLAME CUTTING								
AUTOMATIC	LN FT	0.040	76319	1	1	1.0	1.0	3024
MANUAL	LN FT	0.071	4017	2	2	1.5	1.5	286
3 EDGE PREP-GRINDING								
FLAT	LN FT	0.032	3278	1	2	1.0	1.5	104
VERTICAL	LN FT	0.048	620	2	2	1.5	1.5	29
OVERHEAD	LN FT	0.063	119	2	2	1.5	1.5	8
4 SHAPING								
BREAK	BEND	0.380	0	1	1	1.0	1.0	0
ROLLING	PIECE	0.951	4	1	1	1.0	1.0	4
LINE HEATING	PIECE	10.000	0	1	1	1.0	1.0	0
FURNACE	PIECE	15.000	0	1	1	1.0	1.0	0
PRESS	PIECE	0.019	0	1	1	1.0	1.0	0
MACHINING	CU IN	0.020	0	1	1	1.0	1.0	0
5 FIT UP & ASSEMBLY	JOINT	0.444	9760	2	2	1.5	1.5	4331
6 WELDING, AUTO/MACHINE								
FILLET	LN FT	0.052	84524	2	2	1.5	1.5	4354
BUTT	LN FT	0.3804	7042	2	2	1.5	1.5	2679
7 WELDING, MANUAL								
FILLET								
DOWNHAND	LN FT	0.269	29367	2	2	1.5	1.5	7913
VERTICAL	LN FT	0.404	5551	2	2	1.5	1.5	2244
OVERHEAD	LN FT	0.539	1069	2	2	1.5	1.5	576
BUTT								
DOWNHAND	LN FT	1.030	2447	2	2	1.5	1.5	2521
VERTICAL	LN FT	1.545	462	2	2	1.5	1.5	715
OVERHEAD	LN FT	2.061	89	2	2	1.5	1.5	184
8 MARKING	PIECE	0.100	2440	1	1	1.0	1.0	244
9 HANDLING								
STORAGE	PIECE	0.100	2440	2	2	1.5	1.5	244
TRANSPORTING	ASSY	5.000	24	3	3	2.0	2.0	120
LIFTING	ASSY	5.000	24	4	4	3.0	3.0	120
10 REWORK	JOINT	1.000	966	5	2	4.5	1.5	2897
TOTAL TRADE LABORHOURS								33927
TRADE SUPPORT LABORHOURS (28% OF TRADE LABORHOURS)								9411
TOTAL PRODUCTION LABORHOURS								43338

LABOR HOUR ESTIMATING FORM FOR STRUCTURAL WORK

95KDWT BASE ALTERNATIVE

PROJECT: Entire Tank Section MATERIAL: MS-STs
 FILE: 9550 THICKNESS 0.6 INCHES

WORK PROCESS	WORK UNITS	PROCESS FACTOR (MNHRS/WORK UNIT)	UNIT AMOUNT	ACTUAL STAGE	STANDARD STAGE	ACTUAL FACTOR	STANDARD FACTOR	MNHRS REQ'D
1 OBTAIN MATERIAL RECEIPT & PREP	SQ FT	0.010	132358	1	1	1.0	1.0	1324
2 FLAME CUTTING								
AUTOMATIC	LN FT	0.040	75580	1	1	1.0	1.0	2995
MANUAL	LN FT	0.071	3978	2	2	1.5	1.5	284
3 EDGE PREP - GRINDING								
FLAT	LN FT	0.032	3181	1	2	1.0	1.5	101
VERTICAL	LN FT	0.048	674	2	2	1.5	1.5	32
OVERHEAD	LN FT	0.063	123	2	2	1.5	1.5	8
4 SHAPING								
BREAK	BEND	0.380	0	1	1	1.0	1.0	0
ROLLING	PIECE	0.951	4	1	1	1.0	1.0	4
LINE HEATING	PIECE	10.000	0	1	1	1.0	1.0	0
FURNACE	PIECE	15.000	0	1	1	1.0	1.0	0
PRESS	PIECE	0.019	0	1	1	1.0	1.0	0
MACHINING	CU IN	0.020	0	1	1	1.0	1.0	0
5 FIT UP & ASSEMBLY	JOINT	0.444	9860	2	2	1.5	1.5	4376
6 WELDING, AUTO/MACHINE								
FILLET	LN FT	0.052	83053	2	2	1.5	1.5	4278
BUTT	LN FT	0.3804	6771	2	2	1.5	1.5	2576
7 WELDING, MANUAL								
FILLET								
DOWNHAND	LN FT	0.269	29538	2	2	1.5	1.5	7959
VERTICAL	LN FT	0.404	6255	2	2	1.5	1.5	2528
OVERHEAD	LN FT	0.539	1141	2	2	1.5	1.5	615
BUTT								
DOWNHAND	LN FT	1.030	2408	2	2	1.5	1.5	2481
VERTICAL	LN FT	1.545	510	2	2	1.5	1.5	788
OVERHEAD	LN FT	2.061	93	2	2	1.5	1.5	192
8 MARKING	PIECE	0.100	2465	1	1	1.0	1.0	247
9 HANDLING								
STORAGE	PIECE	0.100	2465	2	2	1.5	1.5	247
TRANSPORTING	ASSY	5.000	24	3	3	2.0	2.0	120
LIFTING	ASSY	5.000	24	4	4	3.0	3.0	120
10 REWORK	JOINT	1.000	974	5	2	4.5	1.5	2921
TOTAL TRADE LABORHOURS								34193
TRADE SUPPORT LABORHOURS (28% OF TRADE LABORHOURS)								9484
TOTAL PRODUCTION LABORHOURS								43677

LABOR HOUR ESTIMATING FORM FOR STRUCTURAL WORK

95KDWT BASE ALTERNATIVE

PROJECT: Entire Tank Section MATERIAL: MS-ST5
 FILE: 9560 THICKNESS 0.6 INCHES

WORK PROCESS	WORK UNITS	PROCESS FACTOR (MNHRS/ WORK UNIT)	UNIT AMOUNT	ACTUAL STAGE	STANDARD STAGE	ACTUAL FACTOR	STANDARD FACTOR	MNHRS REQ'D
1 OBTAIN MATERIAL RECEIPT & PREP	SQ FT	0.010	133734	1	1	1.0	1.0	1337
2 FLAME CUTTING								
AUTOMATIC	LN FT	0.040	74774	1	1	1.0	1.0	2963
MANUAL	LN FT	0.071	3935	2	2	1.5	1.5	281
3 EDGE PREP-GRINDING								
FLAT	LN FT	0.032	3184	1	2	1.0	1.5	101
VERTICAL	LN FT	0.048	629	2	2	1.5	1.5	30
OVERHEAD	LN FT	0.063	122	2	2	1.5	1.5	8
4 SHAPING								
BREAK	BEND	0.380	0	1	1	1.0	1.0	0
ROLLING	PIECE	0.951	4	1	1	1.0	1.0	4
LINE HEATING	PIECE	10.000	0	1	1	1.0	1.0	0
FURNACE	PIECE	15.000	0	1	1	1.0	1.0	0
PRESS	PIECE	0.019	0	1	1	1.0	1.0	0
MACHINING	CU IN	0.020	0	1	1	1.0	1.0	0
5 FIT UP & ASSEMBLY	JOINT	0.444	9116	2	2	1.5	1.5	4046
6 WELDING, AUTO/MACHINE								
FILLET	LN FT	0.052	83759	2	2	1.5	1.5	4315
BUTT	LN FT	0.3804	6526	2	2	1.5	1.5	2483
7 WELDING, MANUAL								
FILLET								
DOWNHAND	LN FT	0.269	29337	2	2	1.5	1.5	7905
VERTICAL	LN FT	0.404	5795	2	2	1.5	1.5	2342
OVERHEAD	LN FT	0.539	1124	2	2	1.5	1.5	606
BUTT								
DOWNHAND	LN FT	1.030	2286	2	2	1.5	1.5	2355
VERTICAL	LN FT	1.545	452	2	2	1.5	1.5	698
OVERHEAD	LN FT	2.061	88	2	2	1.5	1.5	180
8 MARKING	PIECE	0.100	2279	1	1	1.0	1.0	228
9 HANDLING								
STORAGE	PIECE	0.100	2279	2	2	1.5	1.5	228
TRANSPORTING	ASSY	5.000	24	3	3	2.0	2.0	120
LIFTING	ASSY	5.000	24	4	4	3.0	3.0	120
10 REWORK	JOINT	1.000	944	5	2	4.5	1.5	2831
TOTAL TRADE LABORHOURS								33179
TRADE SUPPORT LABORHOURS (28% OF TRADE LABORHOURS)								9203
TOTAL PRODUCTION LABORHOURS								42382

LABOR HOUR ESTIMATING FORM FOR STRUCTURAL WORK
 95KDWT BASE ALTERNATIVE

PROJECT: Entire Tank Section MATERIAL: MS--STS
 FILE : 9570 THICKNESS 0.6 INCHES

WORK PROCESS	WORK UNITS	PROCESS FACTOR (MNHRS/ WORK UNIT)	UNIT AMOUNT	ACTUAL STAGE	STANDARD STAGE	ACTUAL FACTOR	STANDARD FACTOR	MNHRS REQ'D
1 OBTAIN MATERIAL RECEIPT & PREP	SQ FT	0.010	124262	1	1	1.0	1.0	1243
2 FLAME CUTTING								
AUTOMATIC	LN FT	0.040	56902	1	1	1.0	1.0	2255
MANUAL	LN FT	0.071	2995	2	2	1.5	1.5	214
3 EDGE PREP-GRINDING								
FLAT	LN FT	0.032	2279	1	2	1.0	1.5	72
VERTICAL	LN FT	0.048	610	2	2	1.5	1.5	29
OVERHEAD	LN FT	0.063	106	2	2	1.5	1.5	7
4 SHAPING								
BREAK	BEND	0.380	0	1	1	1.0	1.0	0
ROLLING	PIECE	0.951	4	1	1	1.0	1.0	4
LINE HEATING	PIECE	10.000	0	1	1	1.0	1.0	0
FURNACE	PIECE	15.000	0	1	1	1.0	1.0	0
PRESS	PIECE	0.019	0	1	1	1.0	1.0	0
MACHINING	CU IN	0.020	0	1	1	1.0	1.0	0
5 FIT UP & ASSEMBLY	JOINT	0.444	9828	2	2	1.5	1.5	4362
6 WELDING, AUTO/MACHINE								
FILLET	LN FT	0.052	49901	2	2	1.5	1.5	2571
BUTT	LN FT	0.3804	5531	2	2	1.5	1.5	2104
7 WELDING, MANUAL								
FILLET								
DOWNHAND	LN FT	0.269	24699	2	2	1.5	1.5	6655
VERTICAL	LN FT	0.404	6607	2	2	1.5	1.5	2670
OVERHEAD	LN FT	0.539	1152	2	2	1.5	1.5	621
BUTT								
DOWNHAND	LN FT	1.030	2738	2	2	1.5	1.5	2821
VERTICAL	LN FT	1.545	732	2	2	1.5	1.5	1132
OVERHEAD	LN FT	2.061	128	2	2	1.5	1.5	263
8 MARKING	PIECE	0.100	2457	1	1	1.0	1.0	246
9 HANDLING								
STORAGE	PIECE	0.100	2457	2	2	1.5	1.5	246
TRANSPORTING	ASSY	5.000	24	3	3	2.0	2.0	120
LIFTING	ASSY	5.000	24	4	4	3.0	3.0	120
10 REWORK	JOINT	1.000	859	5	2	4.5	1.5	2577
TOTAL TRADE LABORHOURS								30330
TRADE SUPPORT LABORHOURS (28% OF TRADE LABORHOURS)								8413
TOTAL PRODUCTION LABORHOURS								38742

LABOR HOUR ESTIMATING FORM FOR STRUCTURAL WORK

95KDWT BASE ALTERNATIVE

PROJECT: Entire Tank Section MATERIAL: MS-ST5
 FILE: 9580 THICKNESS 0.61 INCHES

WORK PROCESS	WORK UNITS	PROCESS FACTOR (MNHRS/ WORK UNIT)	UNIT AMOUNT	ACTUAL STAGE	STANDARD STAGE	ACTUAL FACTOR	STANDARD FACTOR	MNHRS REQ'D
1 OBTAIN MATERIAL RECEIPT & PREP	SQ FT	0.010	132009	1	1	1.0	1.0	1320
2 FLAME CUTTING								
AUTOMATIC	LN FT	0.040	45338	1	1	1.0	1.0	1797
MANUAL	LN FT	0.071	2386	2	2	1.5	1.5	170
3 EDGE PREP-GRINDING								
FLAT	LN FT	0.032	1583	1	2	1.0	1.5	50
VERTICAL	LN FT	0.048	652	2	2	1.5	1.5	31
OVERHEAD	LN FT	0.063	151	2	2	1.5	1.5	10
4 SHAPING								
BREAK	BEND	0.380	13283	1	1	1.0	1.0	5053
ROLLING	PIECE	0.951	4	1	1	1.0	1.0	4
LINE HEATING	PIECE	10.000	0	1	1	1.0	1.0	0
FURNACE	PIECE	15.000	0	1	1	1.0	1.0	0
PRESS	PIECE	0.019	0	1	1	1.0	1.0	0
MACHINING	CU IN	0.020	0	1	1	1.0	1.0	0
5 FIT UP & ASSEMBLY	JOINT	0.444	8532	2	2	1.5	1.5	3787
6 WELDING, AUTO/MACHINE								
FILLET	LN FT	0.052	21011	2	2	1.5	1.5	1082
BUTT	LN FT	0.3804	7499	2	2	1.5	1.5	2853
7 WELDING, MANUAL								
FILLET								
DOWNHAND	LN FT	0.269	12566	2	2	1.5	1.5	3386
VERTICAL	LN FT	0.404	5173	2	2	1.5	1.5	2091
OVERHEAD	LN FT	0.539	1199	2	2	1.5	1.5	646
BUTT								
DOWNHAND	LN FT	1.030	4485	2	2	1.5	1.5	4620
VERTICAL	LN FT	1.545	1846	2	2	1.5	1.5	2853
OVERHEAD	LN FT	2.061	428	2	2	1.5	1.5	882
8 MARKING	PIECE	0.100	2133	1	1	1.0	1.0	213
9 HANDLING								
STORAGE	PIECE	0.100	2133	2	2	1.5	1.5	213
TRANSPORTING	ASSY	5.000	24	3	3	2.0	2.0	120
LIFTING	ASSY	5.000	24	4	4	3.0	3.0	120
10 REWORK	JOINT	1.000	809	5	2	4.5	1.5	2426
TOTAL TRADE LABORHOURS								33726
TRADE SUPPORT LABORHOURS (28% OF TRADE LABORHOURS)								9355
TOTAL PRODUCTION LABORHOURS								43080

LABOR HOUR ESTIMATING FORM FOR STRUCTURAL WORK

95KDWT BASE ALTERNATIVE

PROJECT:
 FILE :

Entire Tank Section
 95120

MATERIAL: MS-ST5
 THICKNESS 0.86 INCHES

WORK PROCESS	WORK UNITS	PROCESS FACTOR (MNHRS/WORK UNIT)	UNIT AMOUNT	ACTUAL STAGE	STANDARD STAGE	ACTUAL FACTOR	STANDARD FACTOR	MNHRS REQ'D
1 OBTAIN MATERIAL RECEIPT & PREP	SQ FT	0.010	121237	1	1	1.0	1.0	1212
2 FLAME CUTTING								
AUTOMATIC	LN FT	0.055	53768	1	1	1.0	1.0	2983
MANUAL	LN FT	0.095	2830	2	2	1.5	1.5	269
3 EDGE PREP-GRINDING								
FLAT	LN FT	0.048	1359	1	2	1.0	1.5	65
VERTICAL	LN FT	0.095	1372	2	2	1.5	1.5	131
OVERHEAD	LN FT	0.135	99	2	2	1.5	1.5	13
4 SHAPING								
BREAK	BEND	0.380	0	1	1	1.0	1.0	0
ROLLING	PIECE	0.951	4	1	1	1.0	1.0	4
LINE HEATING	PIECE	10.000	0	1	1	1.0	1.0	0
FURNACE	PIECE	15.000	0	1	1	1.0	1.0	0
PRESS	PIECE	0.019	0	1	1	1.0	1.0	0
MACHINING	CU IN	0.020	0	1	1	1.0	1.0	0
5 FIT UP & ASSEMBLY	JOINT	0.444	9500	2	2	1.5	1.5	4216
6 WELDING, AUTO/MACHINE								
FILLET	LN FT	0.062	33721	2	2	1.5	1.5	2084
BUTT	LN FT	0.45965	5684	2	2	1.5	1.5	2613
WELDING, MANUAL								
7 FILLET								
DOWNHAND	LN FT	0.476	10829	2	2	1.5	1.5	5149
VERTICAL	LN FT	0.951	10938	2	2	1.5	1.5	10402
OVERHEAD	LN FT	1.347	789	2	2	1.5	1.5	1063
BUTT								
DOWNHAND	LN FT	1.427	1825	2	2	1.5	1.5	2604
VERTICAL	LN FT	2.853	1844	2	2	1.5	1.5	5260
OVERHEAD	LN FT	4.042	133	2	2	1.5	1.5	538
8 MARKING	PIECE	0.100	2375	1	1	1.0	1.0	238
9 HANDLING								
STORAGE	PIECE	0.100	2375	2	2	1.5	1.5	238
TRANSPORTING	ASSY	5.000	24	3	3	2.0	2.0	120
LIFTING	ASSY	5.000	24	4	4	3.0	3.0	120
10 REWORK	JOINT	1.000	1246	5	2	4.5	1.5	3739
TOTAL TRADE LABORHOURS								43061
TRADE SUPPORT LABORHOURS (28% OF TRADE LABORHOURS)								11944
TOTAL PRODUCTION LABORHOURS								55005

LABOR HOUR ESTIMATING FORM FOR STRUCTURAL WORK

95KDWT BASE ALTERNATIVE

PROJECT: Entire Tank Section MATERIAL: MS-ST5
 FILE : 95121 THICKNESS 0.86 INCHES

WORK PROCESS	WORK UNITS	PROCESS FACTOR (MNHRS/ WORK UNIT)	UNIT AMOUNT	ACTUAL STAGE	STANDARD STAGE	ACTUAL FACTOR	STANDARD FACTOR	MNHRS REQ'D
1 OBTAIN MATERIAL RECEIPT & PREP	SQ FT	0.010	121237	1	1	1.0	1.0	1212
2 FLAME CUTTING								
AUTOMATIC	LN FT	0.055	52763	1	1	1.0	1.0	2927
MANUAL	LN FT	0.095	2777	2	2	1.5	1.5	264
3 EDGE PREP - GRINDING								
FLAT	LN FT	0.048	2467	1	2	1.0	1.5	117
VERTICAL	LN FT	0.095	211	2	2	1.5	1.5	20
OVERHEAD	LN FT	0.135	99	2	2	1.5	1.5	13
4 SHAPING								
BREAK	BEND	0.380	0	1	1	1.0	1.0	0
ROLLING	PIECE	0.951	4	1	1	1.0	1.0	4
LINE HEATING	PIECE	10.000	0	1	1	1.0	1.0	0
FURNACE	PIECE	15.000	0	1	1	1.0	1.0	0
PRESS	PIECE	0.019	0	1	1	1.0	1.0	0
MACHINING	CU IN	0.020	0	1	1	1.0	1.0	0
5 FIT UP & ASSEMBLY	JOINT	0.444	9500	2	2	1.5	1.5	4216
6 WELDING, AUTO/MACHINE								
FILLET	LN FT	0.062	44034	2	2	1.5	1.5	2722
BUTT	LN FT	0.45965	7713	2	2	1.5	1.5	3545
7 WELDING, MANUAL								
FILLET								
DOWNHAND	LN FT	0.476	8998	2	2	1.5	1.5	4278
VERTICAL	LN FT	0.951	768	2	2	1.5	1.5	731
OVERHEAD	LN FT	1.347	361	2	2	1.5	1.5	487
BUTT								
DOWNHAND	LN FT	1.427	1576	2	2	1.5	1.5	2248
VERTICAL	LN FT	2.853	135	2	2	1.5	1.5	384
OVERHEAD	LN FT	4.042	63	2	2	1.5	1.5	256
8 MARKING	PIECE	0.100	2375	1	1	1.0	1.0	238
9 HANDLING								
STORAGE	PIECE	0.100	2375	2	2	1.5	1.5	238
TRANSPORTING	ASSY	5.000	24	3	3	2.0	2.0	120
LIFTING	ASSY	5.000	24	4	4	3.0	3.0	120
10 REWORK	JOINT	1.000	740	5	2	4.5	1.5	2221

TOTAL TRADE LABORHOURS 26360
 TRADE SUPPORT LABORHOURS (28% OF TRADE LABORHOURS) 7312

TOTAL PRODUCTION LABORHOURS 33672

-A115-

Plots for 40KDWT and 95KDWT Alternatives

**Comparison of Tank Steel Area
(One Side of Plate, One Tank)**

Comparison of Tank Steel Weight

Comparison of Tank Weld Lengths

**Comparison of Weld Volumes
Includes Factors for Weld Position and Technique**

**Average Steel Plate Thickness
for One Tank Length**

Comparison of Tank Steel Areas (One Side of Plate, One Tank)

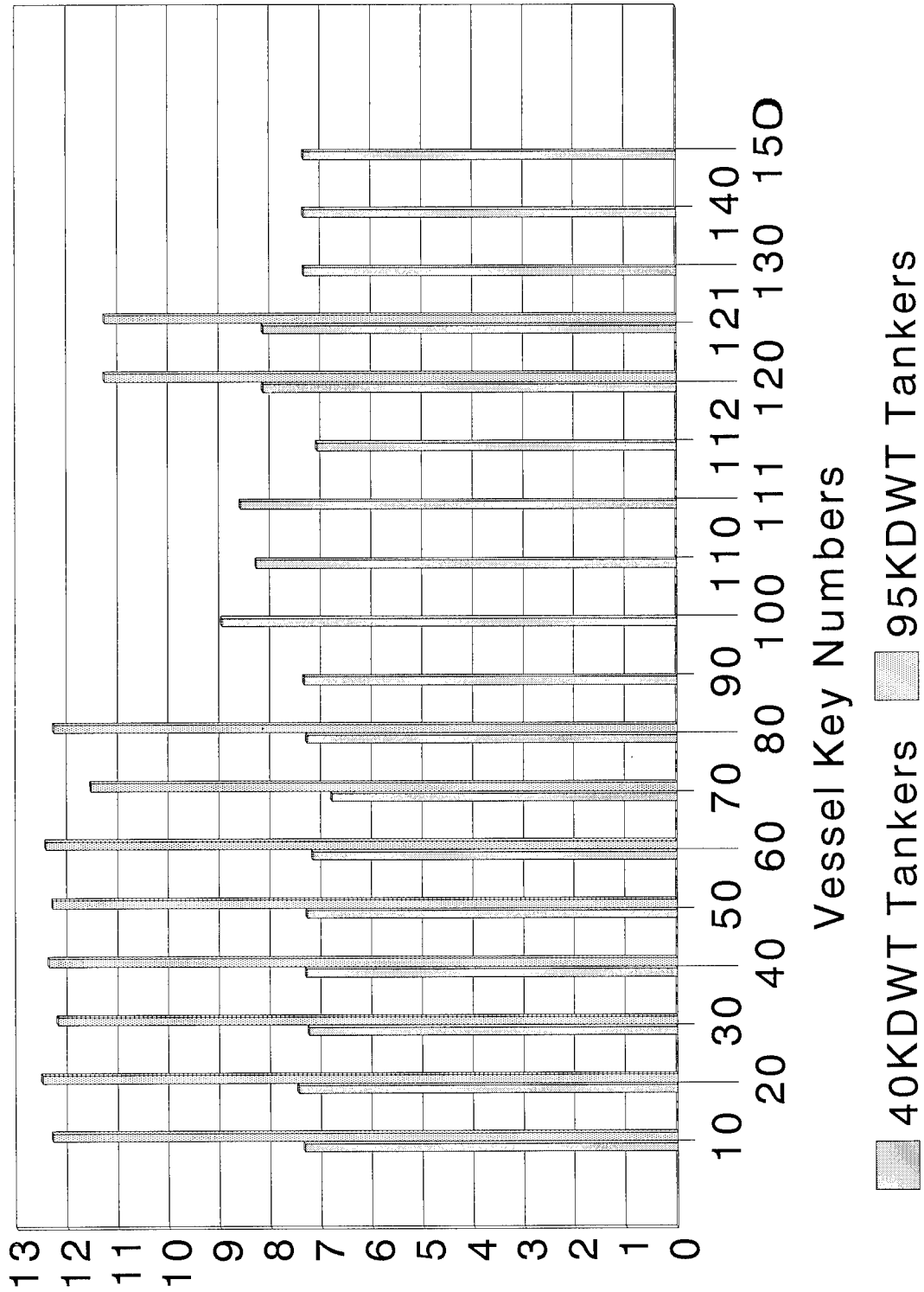

Square Meters
(Thousands)

Vessel Key Numbers

Comparison of Tank Steel Weight

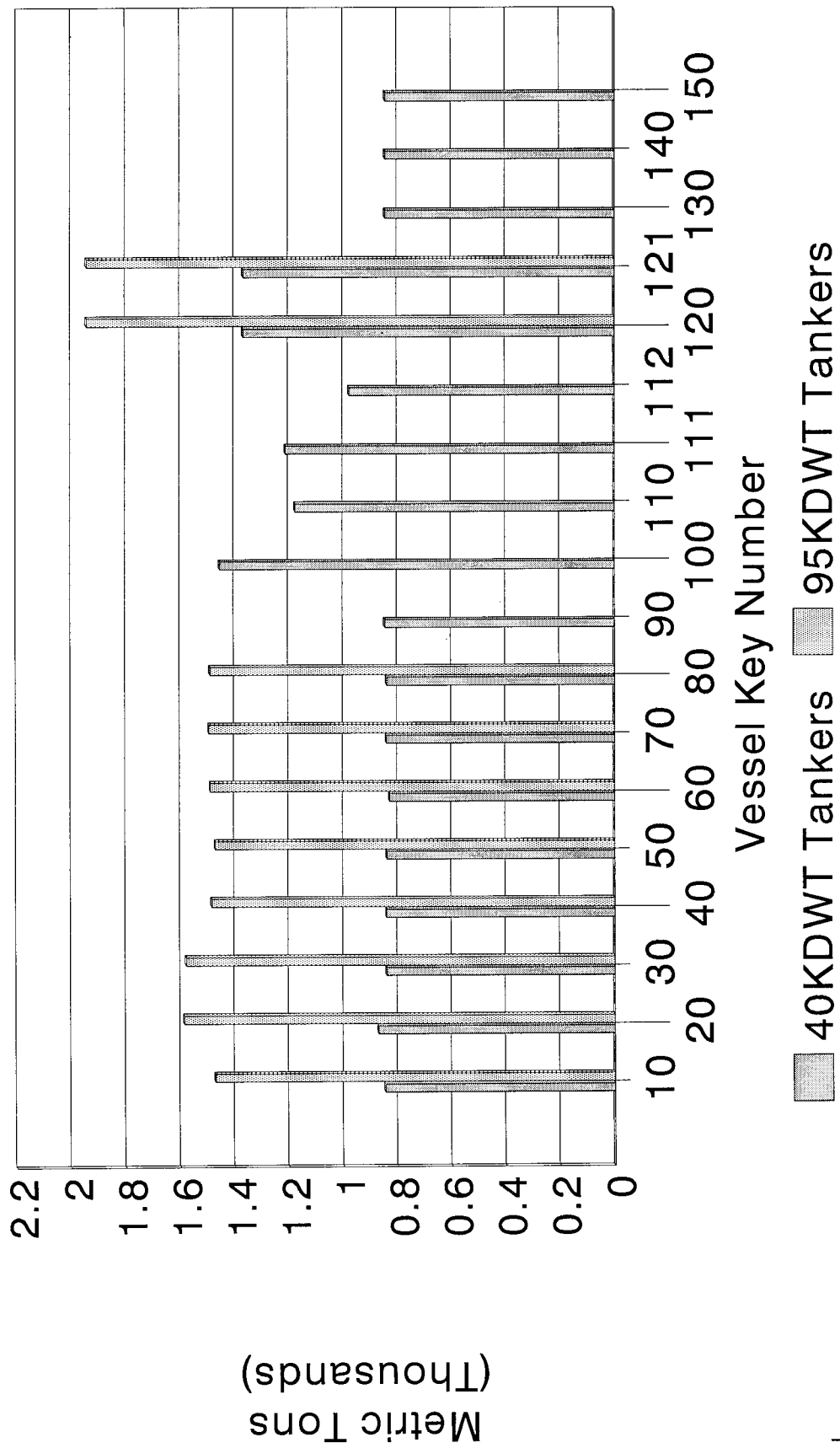

Comparison of Tank Weld Lengths

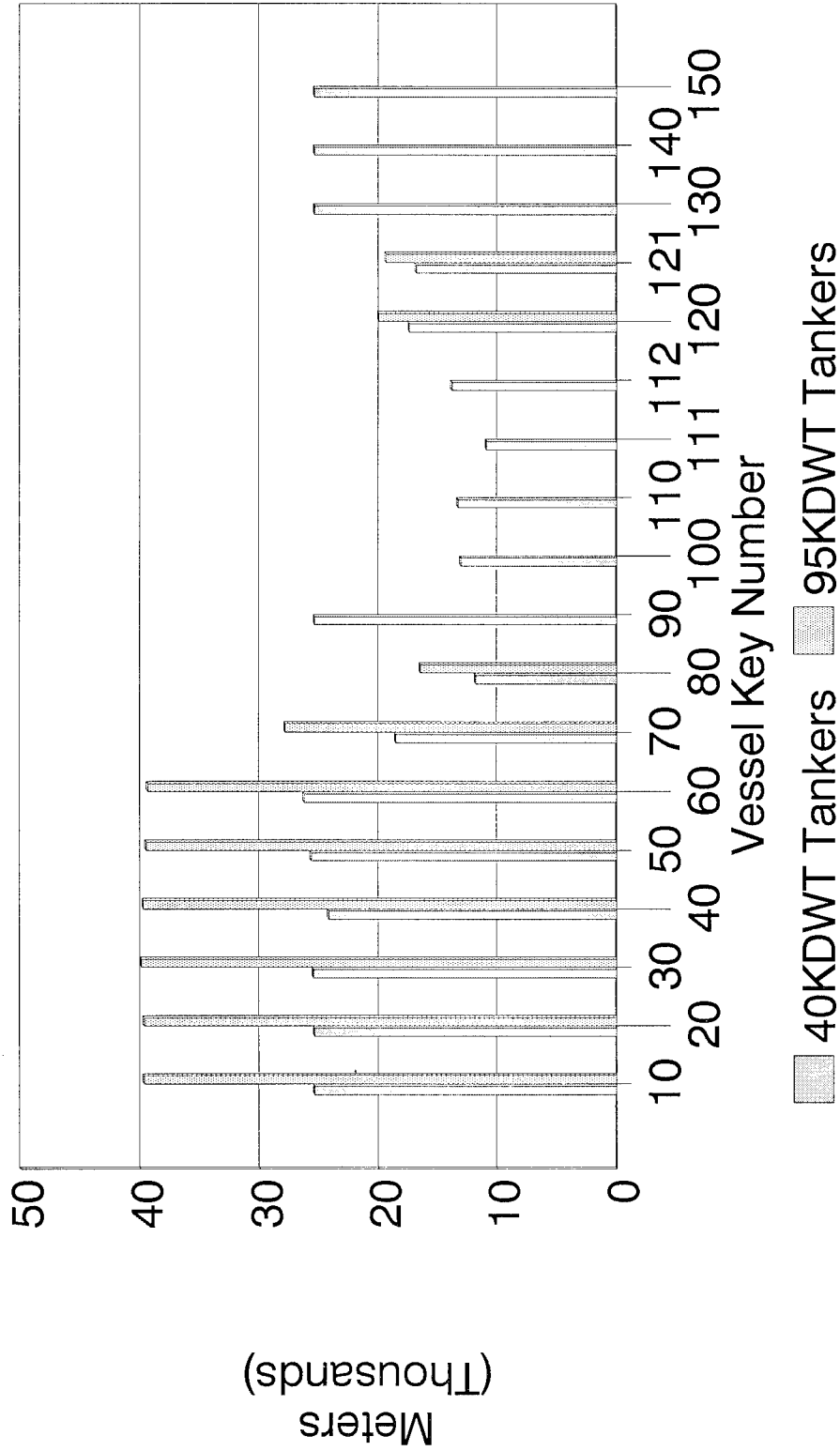

Comparison of Weld Volumes – Includes
Factors for Weld Position & Technique

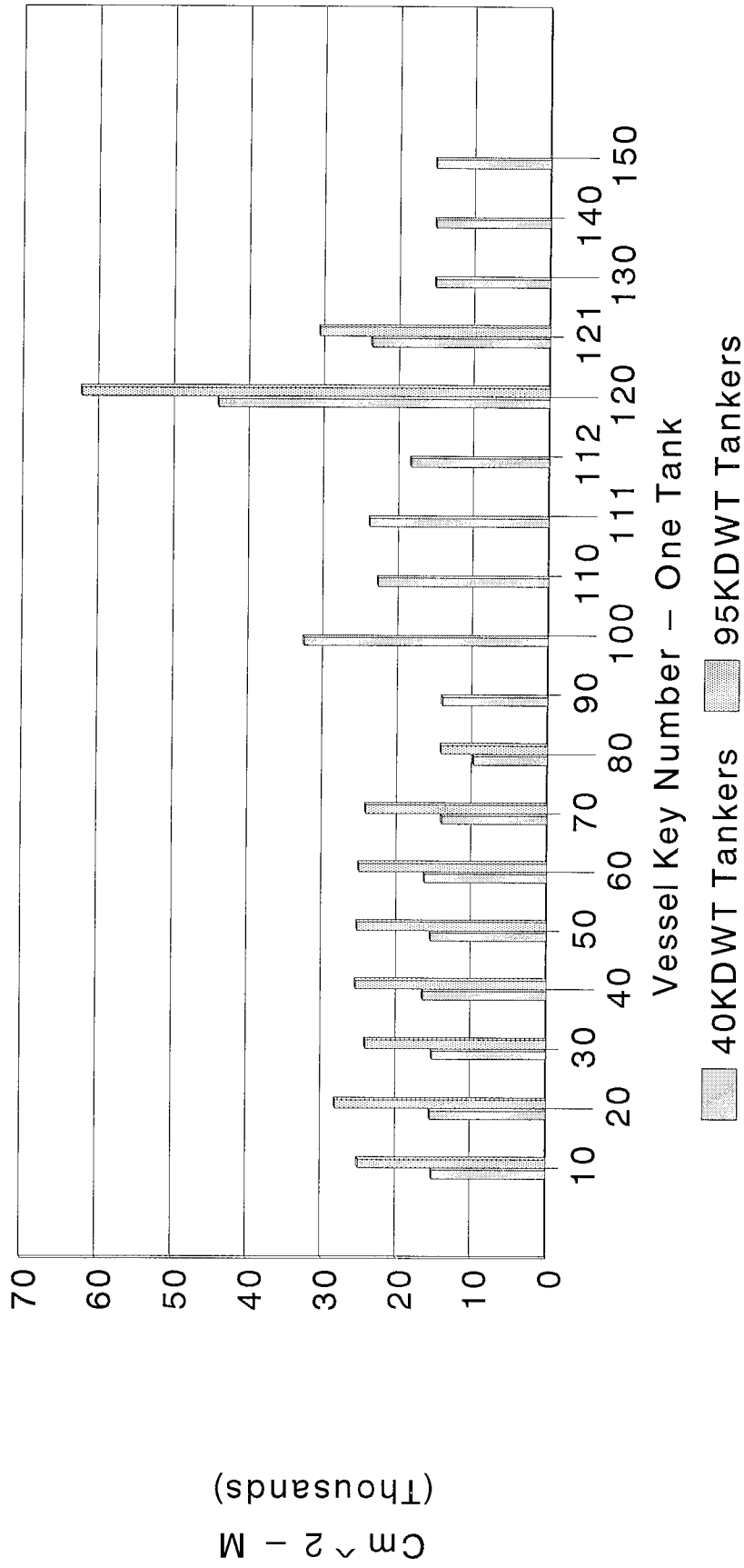

Cm² - M
(Thousands)

Average Steel Plate Thickness For One Tank Length

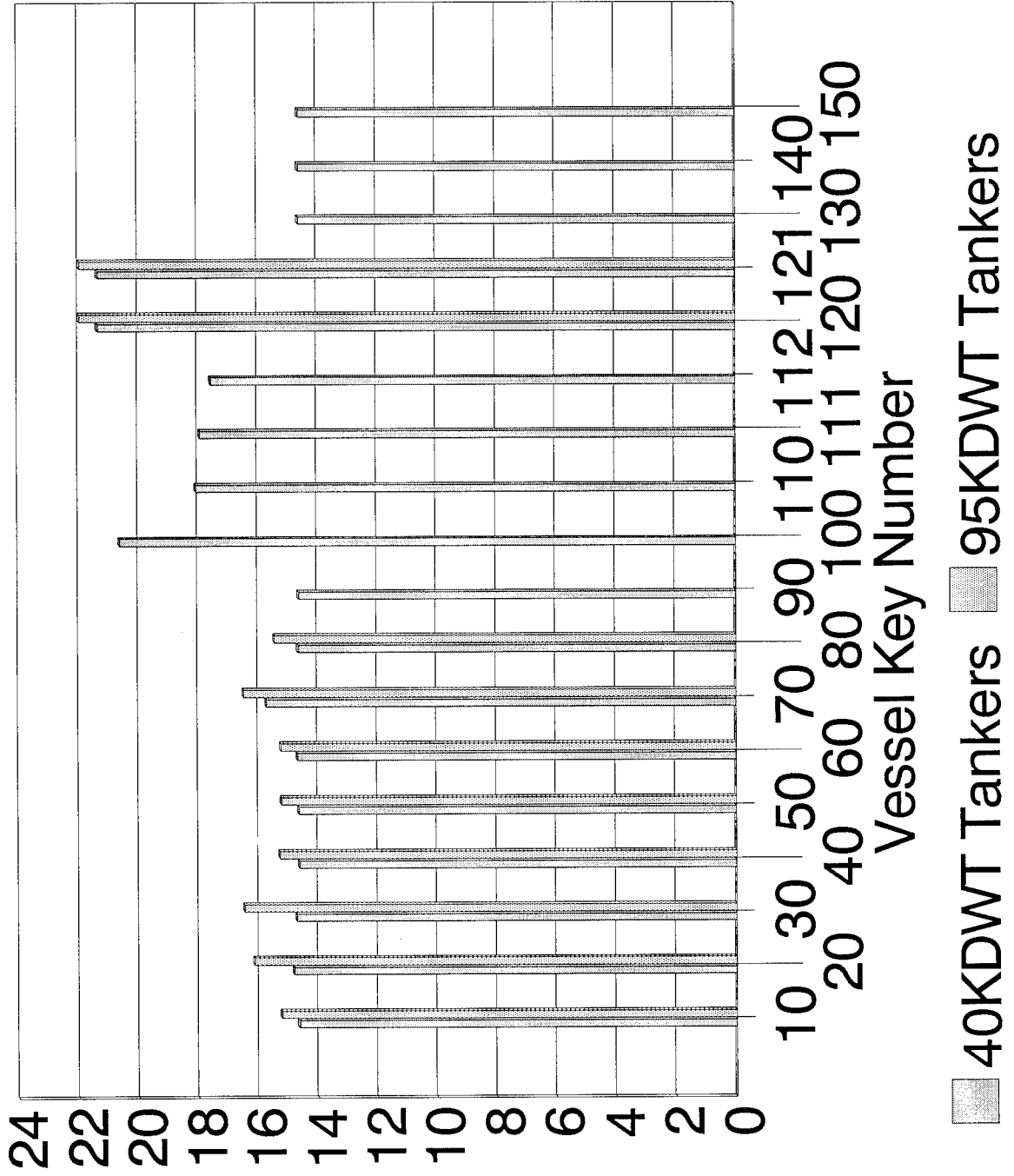

Thickness in MM

Plots for 40KDWT and 95KDWT Alternatives

**Comparison of Estimated Labor Hours - Steel
for One Tank Length**

**Estimated Ship Labor Hours
U.S. 1994 Design and Construction**

**Break Down of Cutting, Preparation and Weld Lengths
40KDWT Alternatives U.S. - One Tank**

**Break Down of Cutting, Preparation and Weld Lengths
95KDWT Alternatives U.S. - One Tank**

Comparison of Labor Hours – Steel – for One Tank Length

Labor Hours (modified Wilkins approach)
(Thousands)

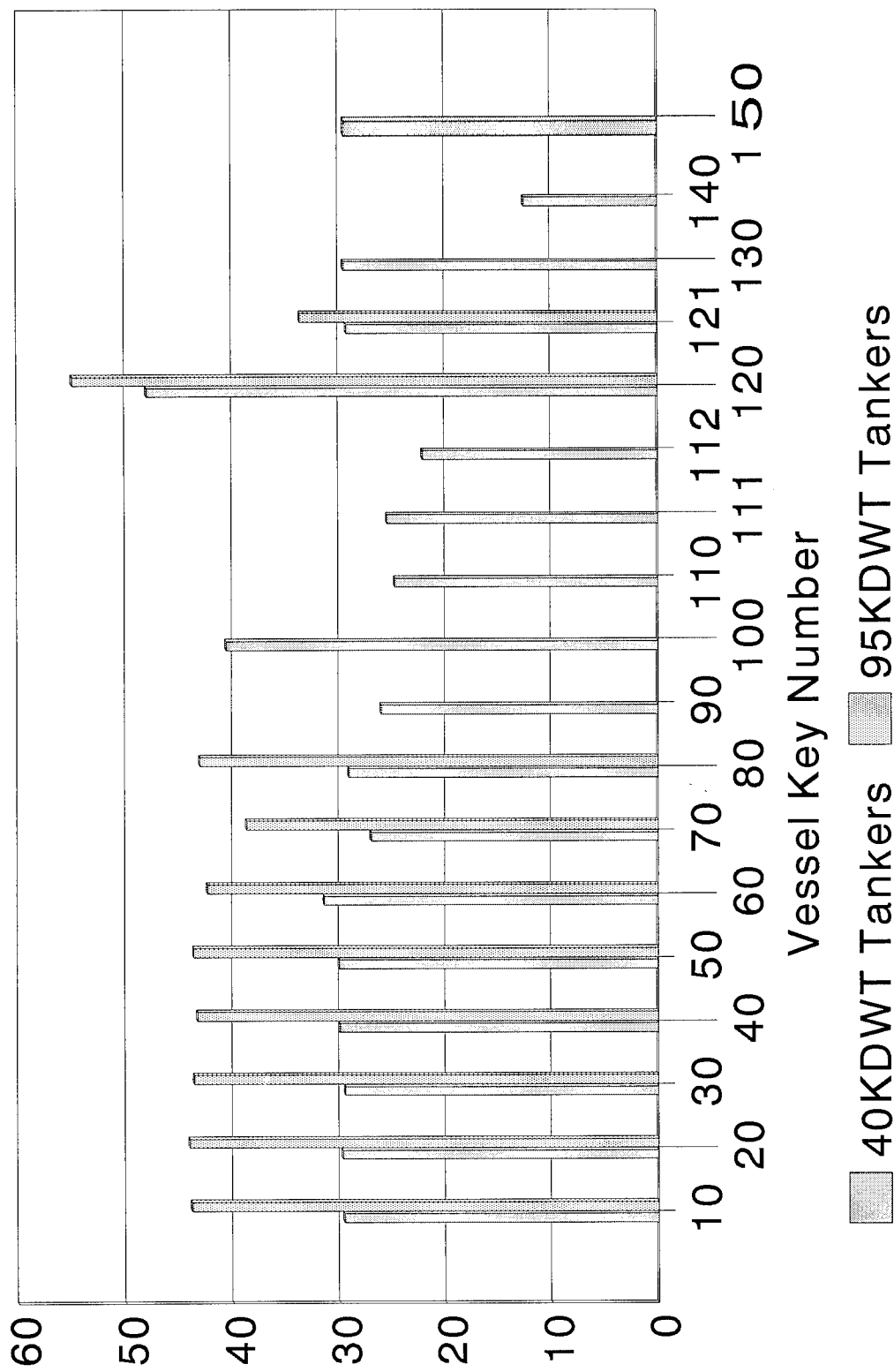

Estimated Ship Labor Hours – U.S. 1994 Design and Construction

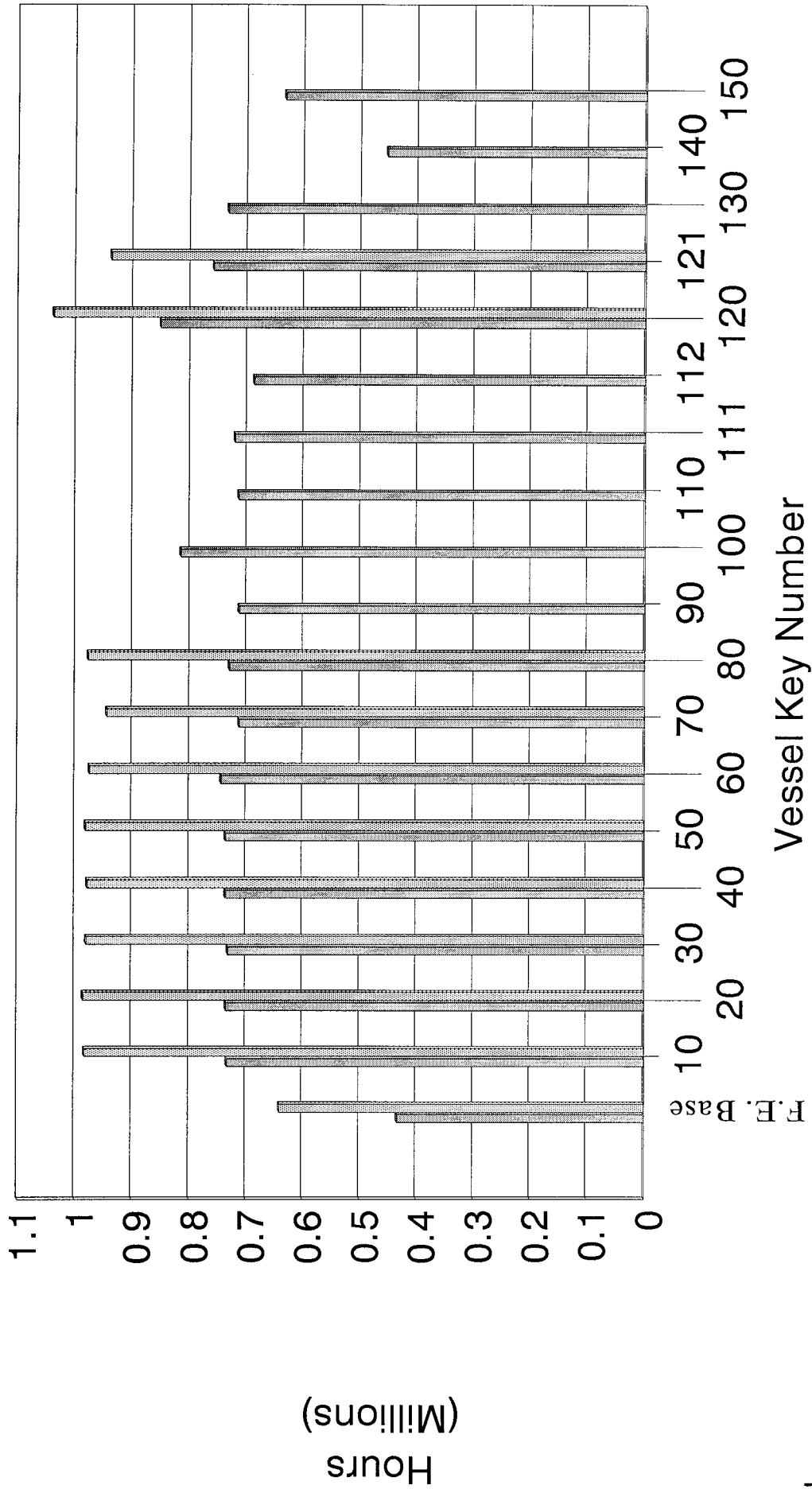

Break Down of Cutting, Prep. and Welds
 40KDWT Alternatives U.S. – One Tank

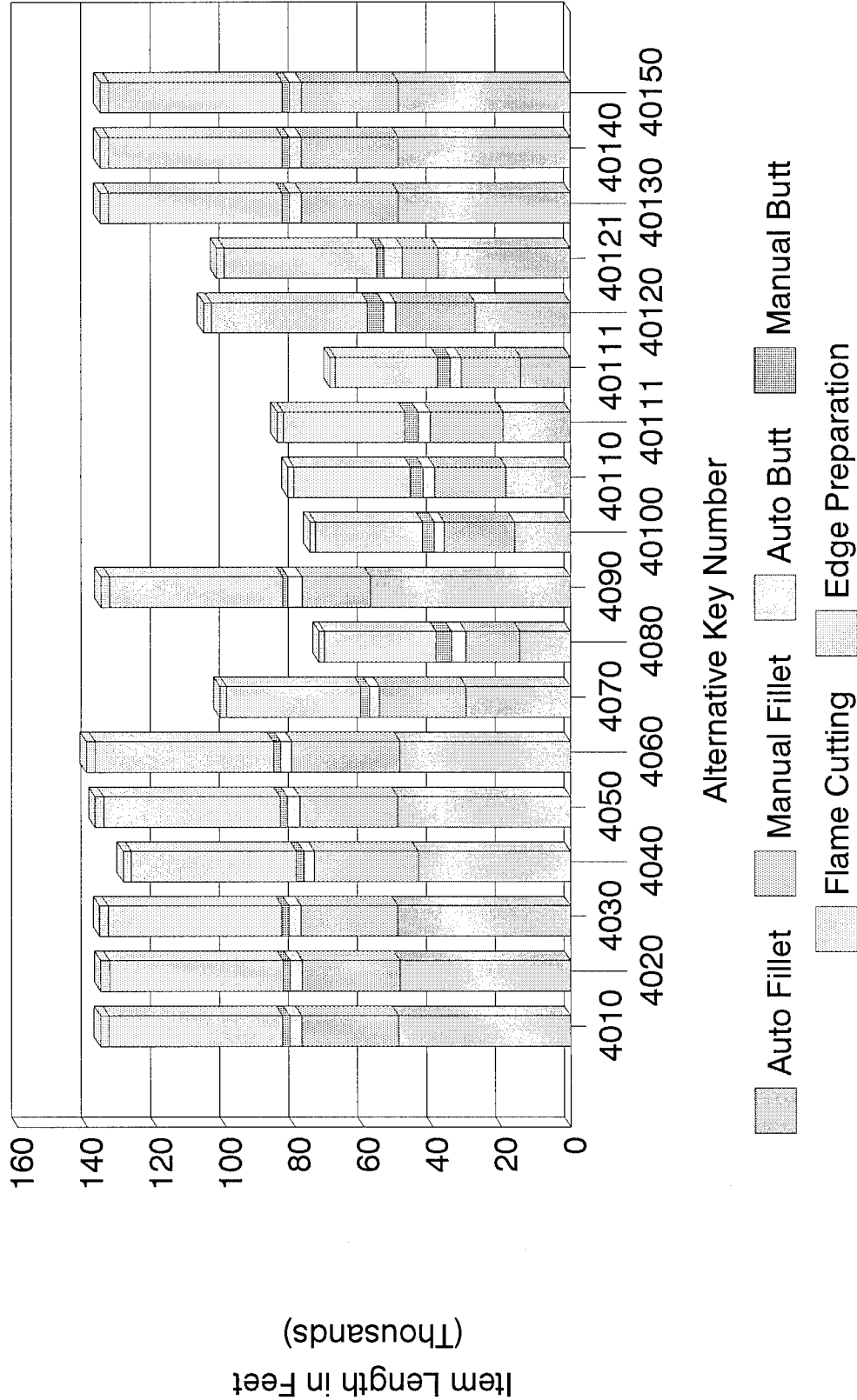

Break Down of Cutting, Prep. and Welds
 95KDWT Alternatives U.S. – One Tank

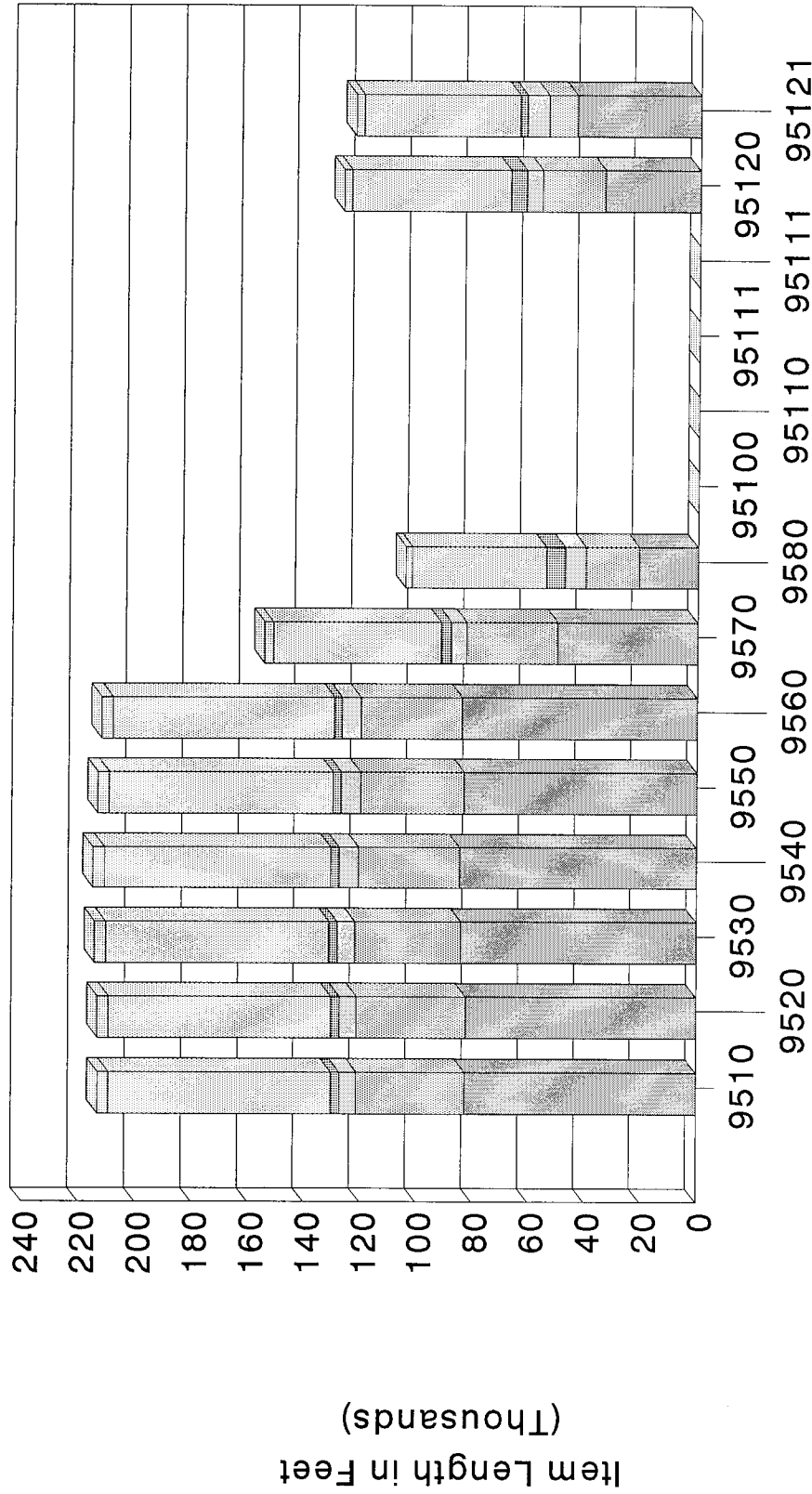

Alternative Key Number

- Auto Fillet
- Manual Fillet
- Flame Cutting
- Auto Butt
- Manual Butt
- Edge Preparation

Project Technical Committee Members

The following persons were members of the committee that represented the Ship Structure Committee to the Contractor as resident subject matter experts. As such they performed technical review of the initial proposals to select the contractor, advised the contractor in cognizant matters pertaining to the contract of which the agencies were aware, and performed technical review of the work in progress and edited the final report.

Mr. Norman Hammer	Maritime Administration
Mr. Fred Siebold	Maritime Administration
Mr. Paul Gilmour	Maritime Administration
Mr. Marty Hecker	U.S. Coast Guard
Mr. Jack Waldman	Naval Sea Systems Command
Mr. James Wilkins	Wilkins Enterprise, Inc.
Mr. William Siekierka	Naval Sea Systems Command, Contracting Officer's Technical Representative
Dr. Robert Sielski Mr. Alex Stavovy	National Academy of Science, Marine Board Liaison
CDR Steve Sharpe	U.S. Coast Guard, Executive Director Ship Structure Committee

COMMITTEE ON MARINE STRUCTURES

Commission on Engineering and Technical Systems

National Academy of Sciences – National Research Council

The COMMITTEE ON MARINE STRUCTURES has technical cognizance over the interagency Ship Structure Committee's research program.

Peter M. Palermo Chairman, Alexandria, VA

Subrata K. Chakrabarti, Chicago Bridge and Iron, Plainfield, IL

John Landes, University of Tennessee, Knoxville, TN

Bruce G. Collipp, Marine Engineering Consultant, Houston, TX

Robert G. Kline, Marine Engineering Consultant, Winona, MN

Robert G. Loewy, NAE, Rensselaer Polytechnic Institute, Troy, NY

Robert Sielski, National Research Council, Washington, DC

Stephen E. Sharpe, Ship Structure Committee, Washington, DC

LOADS WORK GROUP

Subrata K. Chakrabarti Chairman, Chicago Bridge and Iron Company, Plainfield, IL

Howard M. Bunch, University of Michigan, Ann Arbor, MI

Peter A. Gale, John J. McMullen Associates, Arlington, VA

Hsien Yun Jan, Martech Incorporated, Neshanic Station, NJ

John Niedzwecki, Texas A&M University, College Station, TX

Solomon C. S. Yim, Oregon State University, Corvallis, OR

Maria Celia Ximenes, Chevron Shipping Co., San Francisco, CA

MATERIALS WORK GROUP

John Landes, Chairman, University of Tennessee, Knoxville, TN

William H Hartt, Florida Atlantic University, Boca Raton, FL

Horold S. Reemsnyder, Bethlehem Steel Corp., Bethlehem, PA

Barbara A. Shaw, Pennsylvania State University, University Park, PA

James M. Sawhill, Jr., Newport News Shipbuilding, Newport News, VA

Bruce R. Somers, Lehigh University, Bethlehem, PA

Jerry G. Williams, Conoco, Inc., Ponca City, OK

SHIP STRUCTURE COMMITTEE PUBLICATIONS

- SSC-356 Fatigue Performance Under Multiaxial Load by Karl A. Stambaugh, Paul R. Van Mater, Jr., and William H. Munse 1990
- SSC-357 Carbon Equivalence and Weldability of Microalloyed Steels by C. D. Lundin, T. P. S. Gill, C. Y. P. Qiao, Y. Wang, and K. K. Kang 1990
- SSC-358 Structural Behavior After Fatigue by Brian N. Leis 1987
- SSC-359 Hydrodynamic Hull Damping (Phase I) by V. Ankudinov 1987
- SSC-360 Use of Fiber Reinforced Plastic in Marine Structures by Eric Greene 1990
- SSC-361 Hull Strapping of Ships by Nedret S. Basar and Roderick B. Hulla 1990
- SSC-362 Shipboard Wave Height Sensor by R. Atwater 1990
- SSC-363 Uncertainties in Stress Analysis on Marine Structures by E. Nikolaidis and P. Kaplan 1991
- SSC-364 Inelastic Deformation of Plate Panels by Eric Jennings, Kim Grubbs, Charles Zanis, and Louis Raymond 1991
- SSC-365 Marine Structural Integrity Programs (MSIP) by Robert G. Bea 1992
- SSC-366 Threshold Corrosion Fatigue of Welded Shipbuilding Steels by G. H. Reynolds and J. A. Todd 1992
- SSC-367 Fatigue Technology Assessment and Strategies for Fatigue Avoidance in Marine Structures by C. C. Capanoglu 1993
- SSC-368 Probability Based Ship Design Procedures: A Demonstration by A. Mansour, M. Lin, L. Hovem, A. Thayamballi 1993
- SSC-369 Reduction of S-N Curves for Ship Structural Details by K. Stambaugh, D. Lesson, F. Lawrence, C-Y. Hou, and G. Banas 1993
- SSC-370 Underwater Repair Procedures for Ship Hulls (Fatigue and Ductility of Underwater Wet Welds) by K. Grubbs and C. Zanis 1993
- SSC-371 Establishment of a Uniform Format for Data Reporting of Structural Material Properties for Reliability Analysis by N. Pussegoda, L. Malik, and A. Dinovitzer 1993
- SSC-372 Maintenance of Marine Structures: A State of the Art Summary by S. Hutchinson and R. Bea 1993
- SSC-373 Loads and Load Combinations by A. Mansour and A. Thayamballi 1994
- SSC-374 Effect of High Strength Steels on Strength Considerations of Design and Construction Details of Ships by R. Heyburn and D. Riker 1994
- None Ship Structure Committee Publications - A Special Bibliography