

95-1

CRREL REPORT

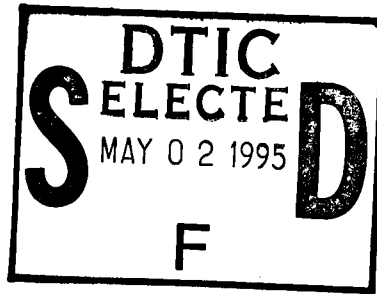

This document has been approved for public release and sale; its distribution is unlimited.

## Cold Regions Mobility Models

Paul W. Richmond, Sally A. Shoop and  
George L. Blaisdell

February 1995

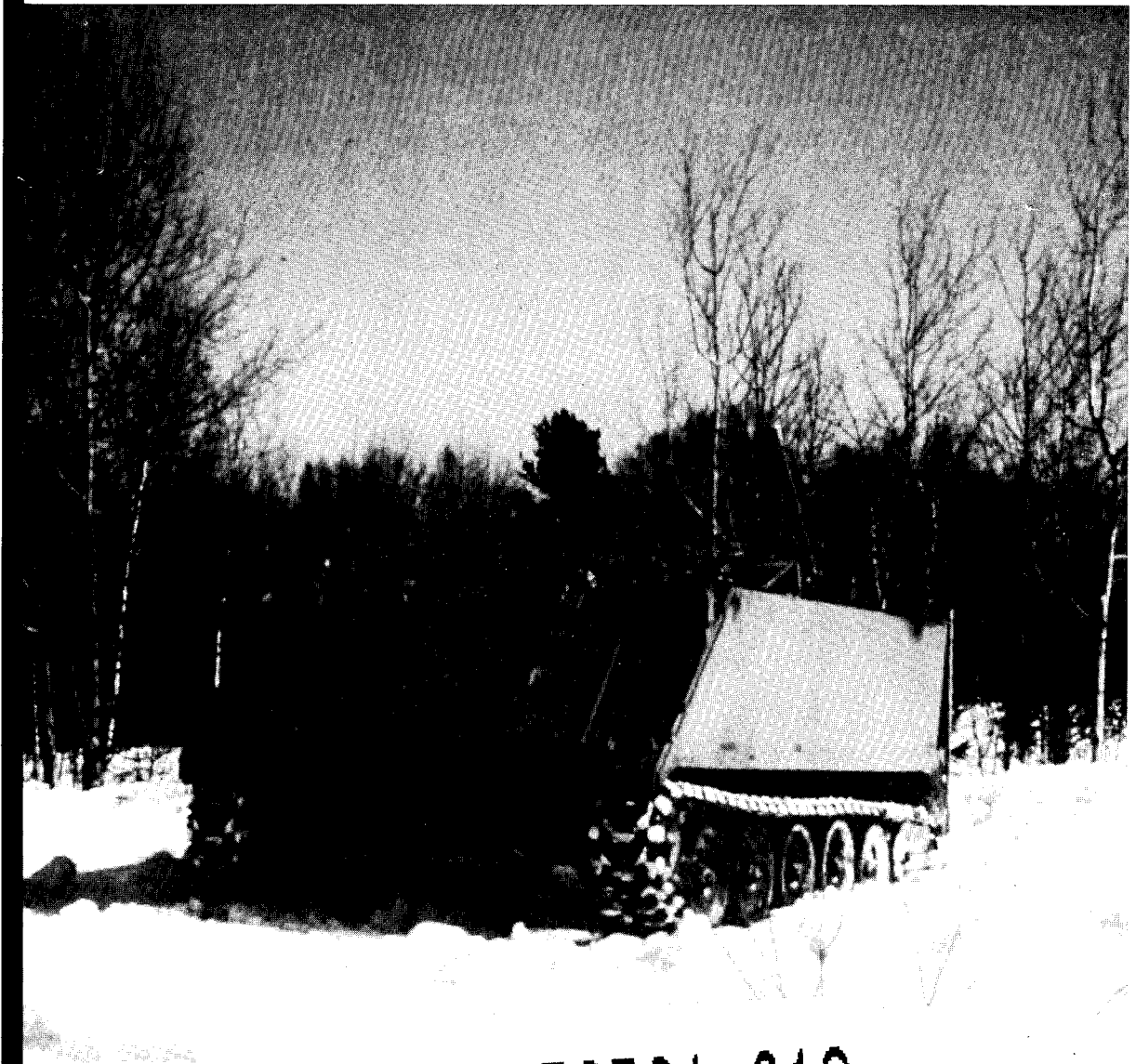

19950501 012

***Abstract***

This report annotates the cold regions mobility prediction routines included in the CAMMS/ALBE mobility models. It further explains the development of the algorithms that are used in these models to describe the interaction of a vehicle with terrain that has been affected by cold weather. The following terrain conditions are discussed: undisturbed snow (shallow and deep); disturbed snow (moderately trafficked and hard packed); ice; and thawing soils. Several combinations of substrates are also considered. A stand-alone computer model is included.

For conversion of SI metric units to U.S./British customary units of measurement consult ASTM Standard E380-89a, *Standard Practice for Use of the International System of Units*, published by the American Society for Testing and Materials, 1916 Race St., Philadelphia, Pa. 19103.



**US Army Corps  
of Engineers**

Cold Regions Research &  
Engineering Laboratory

## Cold Regions Mobility Models

Paul W. Richmond, Sally A. Shoop and  
George L. Blaisdell

February 1995

Accession For	
NTIS CRA&I	<input checked="" type="checkbox"/>
DTIC TAB	<input type="checkbox"/>
Unannounced	<input type="checkbox"/>
Justification .....	
By .....	
Distribution /	
Availability Codes	
Dist	Avail and/or Special
A-1	

DTIC QUALITY INSPECTED 3

Prepared for  
OFFICE OF THE CHIEF OF ENGINEERS

Approved for public release; distribution is unlimited.

## PREFACE

This report was prepared by Paul W. Richmond, Mechanical Engineer; Sally A. Shoop, Research Civil Engineer; and George L. Blaisdell, Research Civil Engineer, all of the Applied Research Branch, Experimental Engineering Division, U.S. Army Cold Regions Research and Engineering Laboratory. Funding for this effort was provided by DA Project 4A762784AT42, Cold Regions Engineering Technology; Work Units M03, *Vehicle Snow Mechanics (Deep Snow)*, M04, *Vehicle Snow Mechanics (Shallow Snow)* and M08, *Mobility Models for Thawing Soils*.

This report was technically reviewed by Karen Faran and Richard Ahlvin.

The contents of this report are not to be used for advertising or promotional purposes. Citation of brand names does not constitute an official endorsement or approval of the use of such commercial products.

## CONTENTS

	Page
Preface .....	ii
Nomenclature .....	v
Introduction .....	1
Background .....	1
Shallow snow .....	2
Undisturbed snow on a firm substrate .....	2
Undisturbed snow on a soft substrate .....	5
Undisturbed snow over ice .....	6
Disturbed, processed and packed snow .....	6
Deep snow .....	7
Ice .....	9
Freezing or thawing ground conditions .....	9
Bearing capacity of freezing ground .....	10
Effect of thawing conditions on vehicle performance .....	11
Speed made good .....	14
Internal motion resistance .....	15
Slopes .....	16
Summary and recommendations .....	16
Literature cited .....	16
Appendix A: Cold Regions Mobility Model CRM-1.F .....	19
Appendix B: FORTRAN code using NRMM/CAMMS variables and format .....	39
Appendix C: Traction coefficients on packed snow .....	53
Appendix D: NRMM checkout data .....	55
Abstract .....	73

## ILLUSTRATIONS

Figure	
1. Shallow vs. deep snow .....	2
2. Vehicle traction on snow .....	3
3. Snow and vehicle characteristics .....	3
4. Vehicle motion resistance in shallow snow .....	4
5. Prediction of vehicle sinkage in shallow snow .....	4
6. Vehicle sinkage analysis .....	4
7. Vehicle traction for snow over ice .....	6
8. Vehicle traction for packed snow .....	7
9. Vehicle traction on ice .....	8
10. Vehicle traction on snow and ice .....	8
11. Critical conditions for trafficability of freezing or thawing ground .....	9
12. Vehicle bearing capacity of frozen ground .....	10
13. Bearing failure modes for a shallow frozen layer over soft ground .....	10
14. Traction coefficient and resistance coefficient vs. water content .....	12
15. Effect of soil thaw depth on net traction and motion resistance coefficients as a function of soil moisture content .....	13
16. Characteristics of Lebanon sand .....	14
17. Idealized traction-slip curve in snow .....	15
18. Generalized traction-slip curves for different surface materials .....	15

**TABLES**

Page

Table

1. Bearing strength of frozen peatland .....	11
2. Soil wetness descriptions .....	12
3. Internal motion resistance coefficients .....	16

## NOMENCLATURE

### Symbols

$a$	Length of tire or track in contact with undisturbed snow (m)
$A_i$	Hard surface contact area for element $i$ ( $m^2$ )
$b$	Width of tire or track (m or in.)
$b_i$	Undeformed tire width or track width (in.)
$f$	Traction multiplier for thawing soil
$g$	Resistance multiplier for thawing soil
$h$	Initial snow depth (cm)
$h_i$	Tire unloaded section height (in.)
$L_i$	Track length (in.)
$n$	Number of wheels on the axle
$N_i$	Normal stress under a wheel or track element $i$ (kPa)
$P$	Maximum load for a given frost depth (MN)
$p$	Contact pressure (same as normal stress) (kPa)
$P_{fg}$	Fine-grain-soil pressure factor (psi)
$r$	Tire (wheel) radius (cm or in.)
$r^2$	Correlation coefficient
RCI	Rating Cone Index
$r_i$	Tire radius (in.)
$R_{\text{internal}}$	Motion resistance due to resistance internal to the vehicle (also called hard surface resistance) (N)
$R_{\text{terrain}}$	Motion resistance due to terrain (snow, soil, ice, etc.) (N)
$R_{\text{thaw}}$	Motion resistance of thawing soil (N or lb)
$S$	Thaw depth in soil (cm)
$s$	Slip in decimal form
$t$	Frost depth in soil (m)
$T_{\text{gross}}$	Total gross traction available on a specified terrain (N)
$T_{\text{net}}$	Total net traction (N)
$T_{\text{thaw}}$	Gross traction available on thawing soil (N or lb)
$V_s$	Vehicle speed (mph or kph)
$w$	Weight on axle (lb)
$W_i$	Wheel or track load (lb)
$W_s$	Driven wheel speed (mph or kph)
$z$	Depth that a vehicle sinks into the terrain (sinkage) (cm)
$z_{\text{max}}$	Maximum vehicle sinkage (snow) (cm)
$z_{\text{soil}}$	Vehicle sinkage into soil (cm)
$\delta_i$	Tire loaded deflection (in.)
$\mu_{\text{ice}}$	Traction coefficient for ice (ratio of tractive force to normal load)
$\theta$	Angle between leading edge of a track and the ground surface
$\rho_0$	Initial snow density ( $Mg/m^3$ )
$\rho_f$	Theoretical critical density ( $Mg/m^3$ )

### Abbreviations

ALBE	Air Land Battlefield Environment
CAMMS	Condensed Army Mobility Model System
CIV	CRREL Instrumented Vehicle
HEMTT	Heavy Expanded Mobility Tactical Truck
HML	Hard Mobile Launcher
HMMWV	High Mobility Multipurpose Wheeled Vehicle
LAV	Light Armored Vehicle
NRMM	NATO Reference Mobility Model
SUSV	Small Unit Support Vehicle
USCS	Unified Soil Classification System
WES	U.S. Army Waterways Experiment Station

# Cold Regions Mobility Models

PAUL W. RICHMOND, SALLY A. SHOOP AND GEORGE L. BLAISDELL

## INTRODUCTION

Over the past several years several empirical and theoretical studies have aimed to predict the mobility of vehicles over winter terrain and the trafficability of that terrain. Most of these efforts were primarily geared toward supporting the U.S. Army Corps of Engineer's AirLand Battlefield Environment (ALBE) demonstration program. Many of these models, or portions thereof, have also been proposed for incorporation into the NATO Reference Mobility Model-II (NRMM-II) (Ahlvén and Haley 1992) and the Condensed Army Mobility Model System (CAMMS) (Falls et al. 1989). These general mobility models can be used to estimate the absolute and relative mobility of vehicles traveling over a variety of terrain types. In addition to being used as military planning and operational tools, the models can also be used to compare specific vehicles or to determine specific vehicle-terrain interactions.

In this report the interaction between winter terrain surface conditions and wheels (driven or undriven) or tracks is discussed for snow, ice, freezing/thawing ground and layered combinations of these conditions. This report brings together supporting documentation, data and theory for individual segments of the cold regions models. A stand-alone program and the FORTRAN code for CAMMS/NRMM implementation of the cold regions models are included as appendices.

## BACKGROUND

The term "mobility" is defined as the efficiency with which a vehicle travels from one point to another. Trafficability refers to the ability of the terrain to support mobility. An effective mobility model must be able to predict

- If a vehicle can propel itself between two points (go/no-go);

- If the vehicle can maneuver or tow a trailer (tractive reserve); and
- How fast the vehicle can get where it's going (speed made good).

The first two issues can be determined at the same time, since a positive value for tractive reserve is required for a "go" condition.

In its simplest form, mobility can be described by a single equation expressing the balance between traction  $T$  and resistance  $R$ . Tractive reserve or net traction  $T_{\text{net}}$  can be calculated from

$$T_{\text{net}} = T_{\text{gross}} - R_{\text{terrain}} - R_{\text{internal}} \quad (1)$$

In eq 1,  $T_{\text{gross}}$  is the maximum tractive force that a specific vehicle is able to generate on a particular terrain. Gross traction is generally a function of

- The tire/track contact pressure;
- The ability of the running gear to engage with the terrain (e.g. the effect of tire tread and traction aids, or track grousers and cleats);
- The shear strength of the top layers of the terrain; and
- The power available to the tire or track.

Motion resistance can be divided into two parts: that produced by external forces and that produced by internal forces. The external resistance  $R_{\text{terrain}}$  is the resistance attributable to the surface and is a function of the strength of the terrain and the vehicle's running gear characteristics. To obtain  $R_{\text{terrain}}$  it is usually necessary to determine the level to which a vehicle sinks below the terrain surface (sinkage,  $z$ ).  $R_{\text{internal}}$  is the resistance caused by friction within the vehicle (tire deformation or track roller resistance, friction in driveline components, etc.).

Speed made good, besides depending on terrain and vehicle characteristics (slip and transmission power curves), is also strongly dependent on operator skill, visibility, terrain roughness and other parameters. Although important, speed made

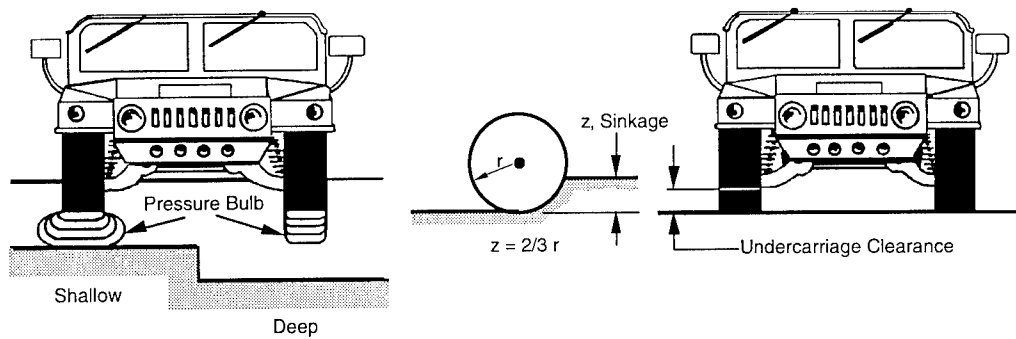

Figure 1. Determining whether a snowpack is considered shallow or deep.

good has not been fully investigated under winter conditions. Except for an approximation of speed reduction caused by vehicle slip in snow (discussed below), it is not addressed by any specific cold regions models. Effects on speed determined for temperate climatic conditions should apply to winter as a first approximation.

Vehicle mobility in snow depends on snow depth, snow density, crystal structure of the snow grains, liquid water content, stratification in the snowpack and virtually anything that affects the mechanical characteristics of the snow cover. An overview of snow characterization measurements used for vehicle mobility and snow pavements is given in Shoop (1993b), Shoop and Alger (1993) and Abele (1990). Snow strength characterization is reviewed in Shapiro et al. (in prep.). To fully describe a snowpack in terms of its physical and mechanical properties is time consuming and requires sophisticated equipment and specialized techniques. Since the models described in this report were designed for tactical use, it was unrealistic for the models to require as input many of the traditional scientific measurements. The algorithms we describe here rely solely on the most basic snow parameters: depth and density.

## SHALLOW SNOW

For mobility purposes, snow depth can be categorized as either shallow or deep, the difference being based on the response of the snowpack to the load applied by the vehicle. If the region of disturbed snow under the vehicle's running gear, called the pressure bulb, extends to the ground or pavement under the snow cover, then the snow is considered shallow. If the pressure bulb is suspended in the snowpack, a deep snow condition exists. An additional constraint for the shallow snow case for our models is that the sinkage of the vehicle

be less than the vehicle ground clearance. Interestingly, whether a given snowpack thickness is deep or shallow depends on the strength of the snow and the characteristics of the vehicle to be operated.

Since an assessment of whether a given snow condition is shallow or deep requires detailed knowledge of the applied load and snowpack response, we suggest two guidelines for making this determination. These guidelines are based on the amount of sinkage calculated in relation to either the tire radius or the undercarriage clearance as illustrated in Figure 1.

## Undisturbed snow on a firm substrate

We describe undisturbed snow as snow that has been driven over by less than four vehicles. We chose this value based on a limited number of measurements of pressure bulb density, where we noted that it takes several wheel passes over the same track to approach the critical density of snow. (Critical density is generally accepted to be  $0.55 \text{ Mg/m}^3$ , which represents the maximum density that can be attained by snow grain rearrangement. An increase in density beyond this requires deformation of individual ice grains.) Further, to be called undisturbed snow it must have a pre-vehicle-passage density of less than  $0.55 \text{ Mg/m}^3$ . This is almost always the case for snow, even in polar regions.

If the terrain underlying the snow has a rating cone index (RCI) (Shoop 1993a) value high enough to fully support the vehicle of interest with no sinkage, mobility is assumed to be unaffected by the substrate. We consider an RCI value of 100 or greater to be adequate to resist sinkage. Nearly all paved surfaces and frozen soils have an RCI greater than 100. For undisturbed snow on a firm substrate, sinkage will only occur in the snow, and calculation of traction and resistance is straightforward.

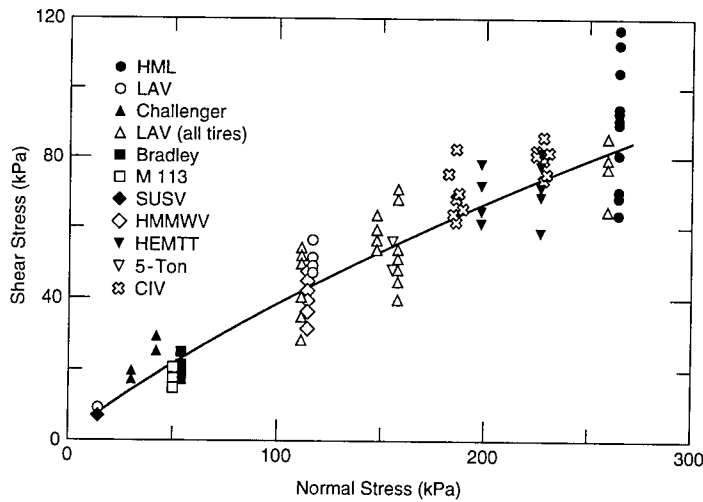

Figure 2. Vehicle traction on snow.

For shallow, undisturbed snow lying on top of a strong substrate, we calculate gross traction (kN) for one driven wheel or track element  $i$  (Blaisdell et al. 1990) as

$$T_{\text{gross},i} = 0.851 N_i^{0.823} A_i \quad (2)$$

where  $N_i$  is the normal stress (kPa) on driving element  $i$  and  $A_i$  is that element's contact area ( $\text{m}^2$ ). The total gross traction for a vehicle is the sum of the traction obtained for each driven wheel or track. This equation is based on data generated from a wide range of vehicle types and sizes (both wheeled and tracked, with contact pressures ranging from 10 to 250 kPa) (Fig. 2). The correlation coefficient for this equation ( $r^2$ ) is 0.97, with data from the standard military vehicles falling within  $-9$  to  $16\%$  of the predicted value.

The equation for motion resistance ( $N$ ) in undisturbed snow is

$$R_{\text{terrain}} = 68.083 (\rho_0 b a)^{0.9135} \quad (3)$$

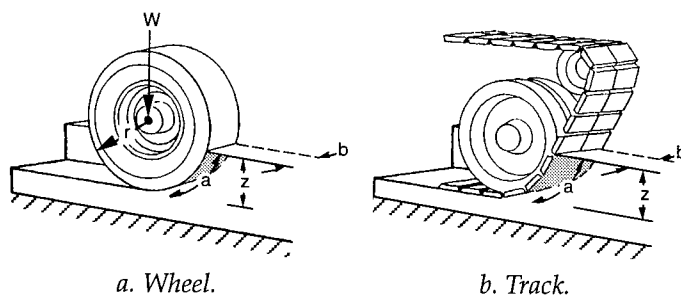

a. Wheel.

b. Track.

Figure 3. Snow and vehicle characteristics.

where  $\rho_0$  = density of the snow immediately in front of the vehicle's running gear ( $\text{Mg}/\text{m}^3$ )  
 $a$  = length of the tire or track in contact with the snow (m)  
 $b$  = maximum width of the tire or track (m) (Fig. 3).

This resistance value is applied to up to four axles or one track set on the vehicles of interest (including any towed units). For unknown reasons, predictions of resistance for the Small Unit Support Vehicle (SUSV) are most reliable when only the leading track set is considered (Richmond et al. 1990). Recent analysis by Richmond (in prep.) indicates that only the first three axles passing through undisturbed snow are important; we apply this equation to the first four axles since the HEMTT with four axles was included in development of eq 3. The data forming the basis of eq 3 are displayed in Figure 4. Although the trend is strong, the  $r^2$  value is low (0.39), and research refining our understanding of vehicle motion resistance in snow is continuing.\*

The length  $a$  of a tire or track contact with snow in eq 3 requires the calculation of vehicle sinkage  $z$  (Fig. 3). This is accomplished by the following equation for sinkage in undisturbed shallow snow:

$$z_{\text{max}} = h \left( 1 - \frac{\rho_0}{\rho_f} \right) \quad (4)$$

where  $z_{\text{max}}$  = maximum predicted sinkage (cm) in snow occurring under the tire or track with maximum contact pressure  $p_{\text{max}}$

$h$  = initial snow depth (cm)

$\rho_0$  and  $\rho_f$  = initial and theoretical final densities ( $\text{Mg}/\text{m}^3$ ), respectively (Fig. 5).

The final density  $\rho_f$  is a function of the applied load. In temperate regions with seasonal snow, the following  $\rho_f$  values are used as estimates; they are based on analysis of field sinkage measurement, as illustrated in Figure 6:

\*A new resistance algorithm presented by Richmond (in prep.) for wheeled vehicles in snow will be incorporated in an NRMM version newer than 2.5.0.

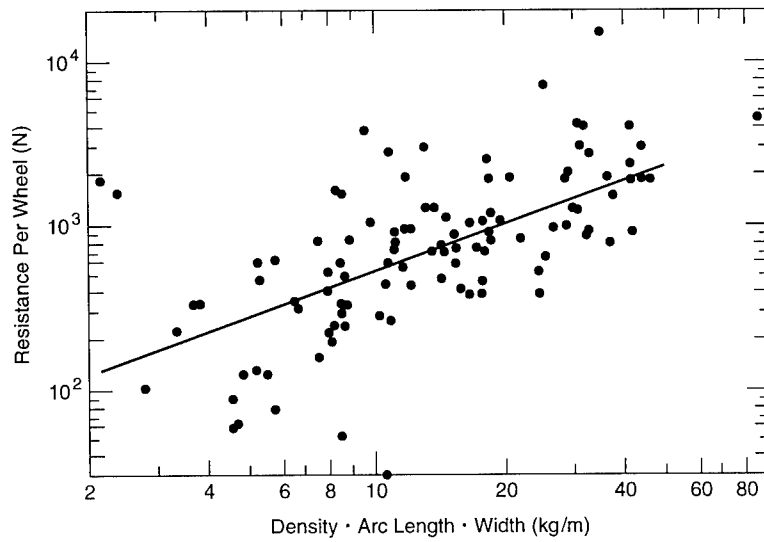

Figure 4. Vehicle motion resistance in shallow snow.

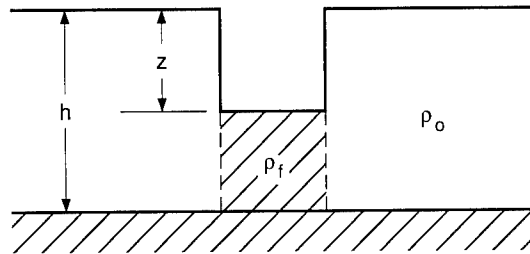

Figure 5. Prediction of vehicle sinkage in shallow snow.

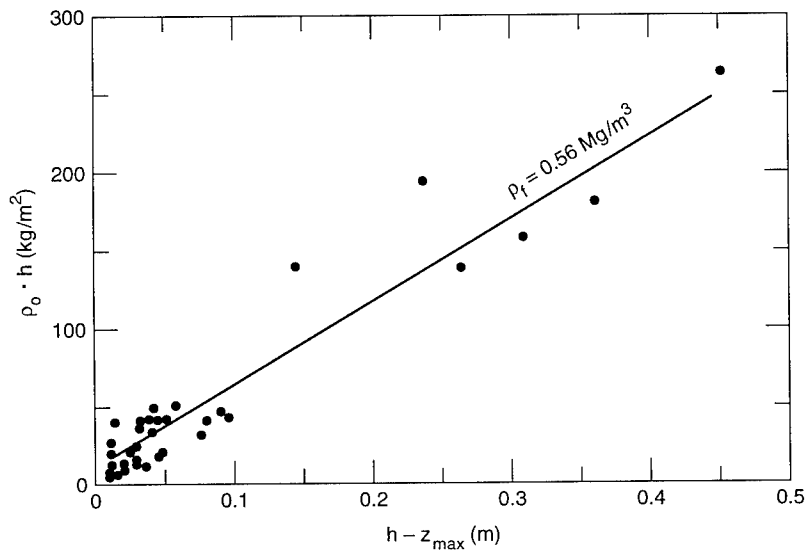

Figure 6. Vehicle sinkage analysis. (From Richmond et al. 1990.)

$$\begin{array}{ll}
p_{\max} \leq 210 \text{ kPa} & \rho_f = 0.50 \text{ Mg/m}^3 \\
p_{\max} > 210 \text{ kPa} & \rho_f = 0.55 \text{ Mg/m}^3 \\
p_{\max} > 350 \text{ kPa} & \rho_f = 0.6 \text{ Mg/m}^3 \\
p_{\max} > 700 \text{ kPa} & \rho_f = 0.65 \text{ Mg/m}^3.
\end{array}$$

The sinkage calculation is also used to estimate whether the snow is deep or shallow.

Once sinkage  $z$  is determined, the value of  $a$  (contact length) for wheeled vehicles is

$$a = r \arccos [(r-z)/r] \quad (5)$$

where  $r$  is the tire radius (cm or in.). For tracked vehicles the equation is

$$a = z/\sin(\theta) \quad (6)$$

where  $\theta$  is the angle between the leading edge of the track and the ground surface (Fig. 3b). Since the vehicle database defined for CAMMS and NRMM does not contain this value, we assume an average value of  $26^\circ$  for  $\theta$  for all tracked vehicles.

#### Undisturbed snow on a soft substrate

For undisturbed snow over a soft soil, additional sinkage occurs as a soil rut is formed. This increases motion resistance as the wheel or track sinks deeper in the snow and possibly below the soil surface.

In this case the total sinkage is estimated to be the sum of the sinkage of the two materials independently. Soil sinkage is calculated ignoring the snow cover and is added to the sinkage determined for the snow from eq 4. The arc length  $a$ , and hence the motion resistance  $R_{\text{terrain}}$ , is calculated based on the combined sinkage:

$$z = z_{\text{soil}} + z_{\text{max}} \quad (7)$$

This approach may be naive in its assumption that the snow and soil can each be treated as separate entities and that their effects can be added to determine the combined effect on a vehicle. However, this assumption is probably adequate for snow depths greater than about 15 cm and soil strengths great enough to suffer less than about 10 cm of sinkage. We also recognize that we have not accounted for the ability of snow to spread and attenuate the vehicle's load. In calculating soil sinkage using this approach, we have placed the entire running gear load and contact pressure on the soil. Although this is clearly incorrect, an accurate determination of the actual load and pressure would involve a sophisticated

analysis that is beyond the scope of our initial models. Further research may show that these shortcomings can be accounted for by lowering the RCI value used to separate firm from soft substrates. We have also ignored the possibility that shear zones could form between the snow and the soil (most likely in shallow snow), which would affect both traction and resistance calculations.

Soil sinkage is calculated separately for wheeled and tracked vehicles using the sinkage equations of Willoughby.\* The equations for wheeled and tracked vehicles, respectively, are

$$z_{\text{soil}} = \frac{10 r_i}{\left[ \frac{\text{RCI } 2 r_i b_i}{W_i (1 - \delta_i / h_i)^{3/2} s^{1/5}} \right]^{5/3}} \quad (\text{Wheeled})$$

$$z_{\text{soil}} = 0.00443 L_i e^{(5.889 W_i / \text{RCI } b_i L_i)} \quad (\text{Tracked}) \quad (9)$$

$$z_{\text{soil}} = 0 \quad (\text{If RCI} \geq 100) \quad (10)$$

where RCI = rating cone index

$L_i$  = track length (in.)

$b_i$  = undeflected tire width or track width (in.)

$r_i$  = tire radius (in.)

$W_i$  = wheel or track load (lb)

$\delta_i$  = tire loaded deflection (in.)

$h_i$  = tire unloaded section height (in.)

$s$  = slip in decimal form (chosen to be 0.05 for Cold Regions Models) for the running gear element  $i$ .

*Combined sinkage less than or equal to the snow depth*

For the situation where sinkage occurs in the soil (RCI < 100) but  $z$  is still less than the snow depth  $h$ , we assume that the motion resistance is only that due to snow. While the combined  $z$  from eq 7 is larger than  $z_{\text{max}}$  from the snow, the tire or track is still contained completely in the snow-pack and thus its resistance to motion is caused primarily by snow deformation. Equations 2 and 3 are used to calculate traction and resistance.

\* Personal communication with W. Willoughby, U.S. Army Waterways Experiment Station, 1992.

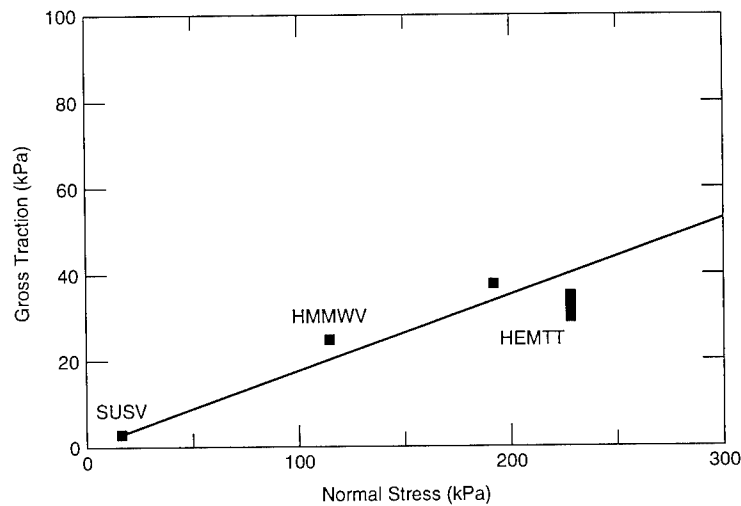

Figure 7. Vehicle traction for snow over ice. (From Richmond et al. 1990.)

#### Combined sinkage greater than the snow depth

For some situations it is possible that the combined sinkage  $z$  is greater than the snow depth. In this case the motion resistance due to the sinkage into the soil must be added to that from the snow to determine the total resistance. Unfortunately calculating the resistance for a sinkage greater than the snow depth involves knowing the interaction of the snow and the substrate during deformation and shearing and is far beyond the scope of current understanding. Thus, we have no provisions for calculating the additional resistance or the effect on traction when  $z$  is greater than  $h$ . The model calculates the resistance based on the total sinkage considered to be in snow, and traction is based on the condition specified as if this case did not occur.

#### Undisturbed snow over ice

The algorithms above have all assumed that shear displacement in the terrain as a result of the tractive demand of the running gear occurs within the snowpack. In this assumption we are claiming that the internal shear strength of the snow below a tractive element is less than or equal to the shear strength of the substrate or the interface between the substrate and the snow. This is most likely true for all situations except when the snow overlies ice. This could occur on a frozen river or lake or on a road surface where precipitation started as freezing rain prior to becoming snow. In this case the interfacial shear strength between the snow and ice is almost guaranteed to be less than the shear strength within

the snow. Thus, for shallow snow where the pressure bulb is in contact with the ice, we assume that traction will be governed by the interfacial properties.

For undisturbed shallow snow deeper than 1 cm lying on top of ice, we use the following traction equation:

$$T_{\text{gross}_i} = 0.127 N_i^{1.06} A_i \quad (11)$$

which was presented by Richmond et al. (1990) (Fig. 7). The value of 1 cm was chosen to reflect the point at which the snow/ice interface would have effectively no strength, and the traction generated would be the same as that on a clear ice surface.  $R_{\text{terrain}}$  for this case is calculated using eq 3.

#### Disturbed, processed and packed snow

The physical and mechanical properties of a snowpack change significantly when it is driven over repeatedly. After a large volume of traffic, the snow's characteristics cease to change dramatically as the result of tire loads, and the snow is then considered to be packed.

Vehicle operators tend to follow in the tracks of preceding vehicles. We assume that after four passes in the same track, the snow has reached its critical density, and succeeding vehicles will be traveling on packed snow. Usually, packed and disturbed snow conditions can only be formed over a firm substrate.

In some cases an area of snow is mechanically processed to produce a snow road that is capable of supporting wheeled vehicle traffic (Abele 1990).

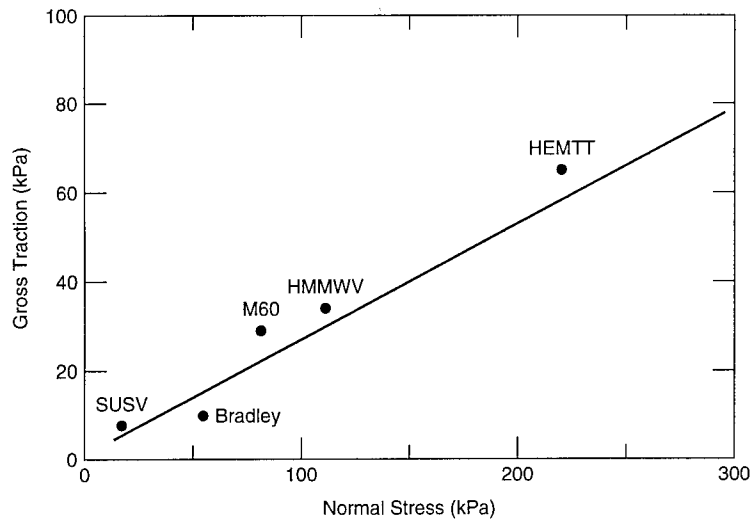

Figure 8. Vehicle traction for packed snow. (From Richmond et al. 1990.)

We assume that disturbed, packed or processed snow attains a density of at least  $0.55 \text{ Mg/m}^3$ . Since only vehicles that have a very high ground pressure are expected to cause any sinkage on these surfaces,  $R_{\text{terrain}}$  for this case becomes zero for all vehicles.

The equation we use to predict traction on packed snow is

$$T_{\text{gross}_i} = 0.321N_i^{0.97}A_i \quad (12)$$

and is shown in Figure 8.

A comparison of measured and predicted traction on shallow, groomed snow is discussed in Appendix C.

For disturbed snow deeper than 1 cm over an ice surface, we assume that a bond has developed between the packed snow and ice; we use eq 12 for traction in this case and again assume that the  $R_{\text{snow}}$  is zero.

## DEEP SNOW

Deep snow occurs when the deformation bulb under a wheel or track does not extend down through the snowpack to an underlying surface (Fig. 1). Since vehicle sinkage depends on ground pressure, it is apparent that the presence of a deep snow condition is a function of the snow depth, bearing capacity (generally reported in the form of a pressure–sinkage relationship) and vehicle characteristics. Additionally we include as deep snow the cases where sinkage is greater than  $2/3$

of the wheel radius and where sinkage is greater than the ground clearance for wheeled or tracked vehicles. This added set of criteria for defining a deep snow condition recognizes that when a vehicle sinks to the point where the majority of its running gear is below the snow surface, added sources of resistance arise beyond simple compaction of the snow in front of the tire or track.

Both traction and resistance are different for deep snow than for shallow snow. However, there are few published results for deep snow mobility with wheeled and tracked vehicles, making it difficult to write accurate prediction equations. Thus, we used the shallow snow results as a starting point for the deep snow models. We began by assuming that the deep snow condition only alters traction to a small degree, since the majority of the tractive force is generated in the fully compacted portion of the pressure bulb. The tractive force developed in deep snow is most likely somewhat less than for shallow snow, because the pressure bulb will have a slightly lower density. The degree of reduction in density and tractive force is unknown, so we chose to use the shallow snow traction expression (eq 2) for deep snow.

Motion resistance generated as the result of sinkage into the snow exists in deep snow just as it did for shallow snow. In the vast majority of cases, sinkage is greater in deep snow, so resistance is higher, since a greater portion of the wheel or track is involved in compacting and displacing snow. However, several additional sources of resistance may arise in deep snow. For example, por-

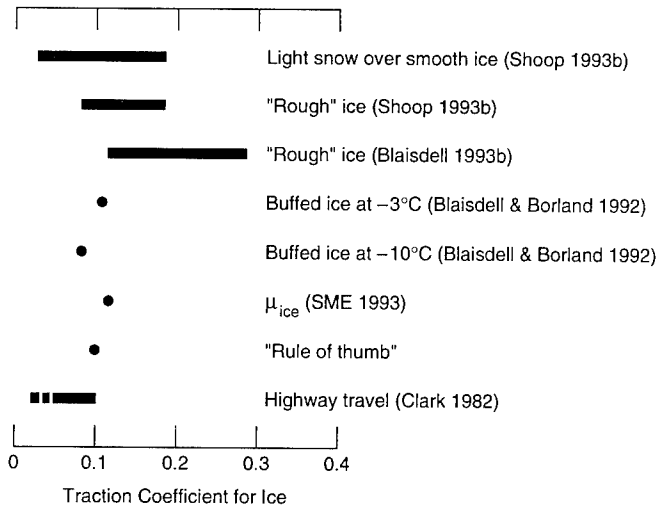

Figure 9. Vehicle traction on ice.

tions of the undercarriage may drag in the snow as the result of greater sinkage. In very deep snow, even the front face of a vehicle may be "plowing" snow.

Lacking quantitative data for motion resistance in deep snow, we based our initial model of resistance in deep snow on a combination of analytical considerations and our collective observations of the behavior of vehicles operating in deep snow conditions. Our model of resistance in deep snow uses "multipliers" applied to the shallow snow resistance expression (eq 3). These multipliers were chosen to represent the significant increase in resistance experienced when snow is being pushed forward by the near-vertical face of the tire when sinkage is large. For tracked vehicles the concern is primarily interference with the undercarriage. The multipliers are as follows:

For wheeled vehicles:

$$\rho_0 < 0.15 \text{ Mg/m}^3$$

- 1) If sinkage  $\geq$  wheel radius, multiply resistance by 1.5.
- 2) If sinkage  $\geq$  ground clearance, add 1.5 to multiplier above.

$$\rho_0 \geq 0.15 \text{ Mg/m}^3$$

- 1) If sinkage  $\geq$  (0.666  $\times$  wheel radius) but less than wheel radius, multiply resistance by 1.5.
- 2) If sinkage  $\geq$  wheel radius, multiply resistance by 2.5.
- 3) If sinkage  $\geq$  ground clearance, add 1.5 to multipliers above.

For tracked vehicles:

$$\rho_0 < 0.15 \text{ Mg/m}^3$$

- 1) If sinkage  $\geq$  ground clearance, multiply resistance by 2.5.

$$\rho_0 \geq 0.15 \text{ Mg/m}^3$$

- 1) If sinkage  $\geq$  ground clearance, multiply resistance by 4.0.

In formulating these guidelines, we took ground clearance to be the height above ground of the lowest major component of the undercarriage of a vehicle, measured while it is parked on a firm surface. Our experience suggests that small, or a low number of, protuberances generate little additional resistance (Richmond, in prep.). However, the NRMM/CAMMS database lists ground clearance as the distance from the lowest component to the ground. Therefore, our model will yield conservative output (it will err on the side of overprediction for  $R_{\text{terrain}}$ ).

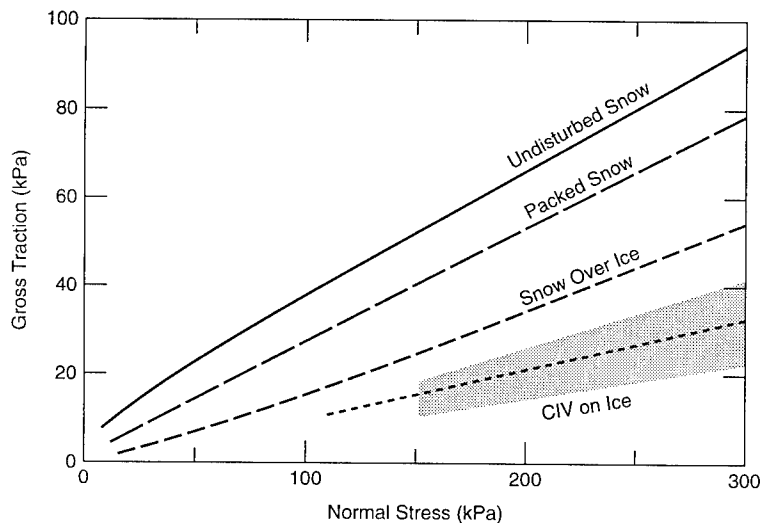

Figure 10. Vehicle traction on snow and ice.

## ICE

Ice traction is a function of surface roughness, temperature, tire compound and vehicle speed (Blaisdell and Borland 1992). While it may be possible to easily incorporate ice temperature into the NRMM/CAMMS database, it is unlikely that either tread compound or surface roughness could be included with any degree of accuracy in the near term. So, to treat the case of traction on ice, we have reviewed published data (Fig. 9) (Shoop 1993b) and taken a conservative value of 0.1. Therefore, we calculate traction on ice as

$$T_{\text{gross}_i} = 0.1 N_i A_i. \quad (13)$$

The traction equations for ice and snow are compared in Figure 10. A model of ice traction utilizing traction aids exists (Blaisdell 1984), but it requires as input geometric features of the devices, which are not available in the current Army mobility database.

Because of the essentially undeformable nature of ice under a vehicle's running gear, motion resistance  $R_{\text{terrain}}$  is assumed to be zero.

## FREEZING OR THAWING GROUND CONDITIONS

Freezing ground can often increase vehicle mobility, while thawing ground nearly always reduces mobility. An additional issue of importance is the possibility of severe terrain damage when vehicles operate in areas with thawing conditions. Three critical conditions for vehicle mobility on freezing and thawing soils are illustrated in Figure 11.

When a wet, weak soil begins to freeze (Fig. 11a), the strong frozen layer on top will increase the bearing capacity of the ground. The bearing capacity—the ability of the soil to support a vehicle—can be expressed as a function of the frost depth  $t$  and the relative wetness of the frozen ground surface.

During spring and intermittent thaws, a thawed layer of soil develops over the frozen soil (Fig. 11b). In the top layer the soil moisture is higher than normal due to snowmelt, rain and the increased water drawn to the soil layer during the freezing process. This moisture is trapped in the shallow thawed layer, creating a wet and weak layer of soil over the stronger frozen layer. The reduction in vehicle mobility will be a function of the strength of the composite soil, which can be expressed in terms of thaw depth  $S$  and the soil moisture in the thawed layer. As the thaw progresses deeper (Fig. 11c), the frozen layer becomes too distant to add support to the vehicle or strength to the effective soil system, but it often continues to restrict the soil drainage.

Our current state of development of mobility modeling for freezing ground is limited to go/no-go predictions based on whether the ground can support the vehicle. For thawing ground we can make more quantitative predictions of the effect on traction and motion resistance. Our models assume a baseline traction and motion resistance for the soil of interest in its fully thawed state. The effects of freezing and thawing are expressed as modifications (multipliers) to the baseline values for traction and motion resistance. The effects of other factors (e.g. vegetation and slope) on mobility during freezing

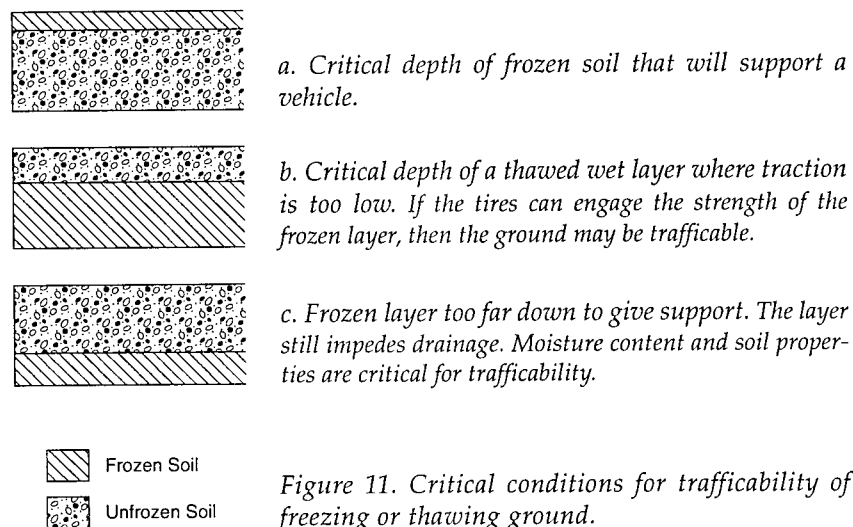

Figure 11. Critical conditions for trafficability of freezing or thawing ground.

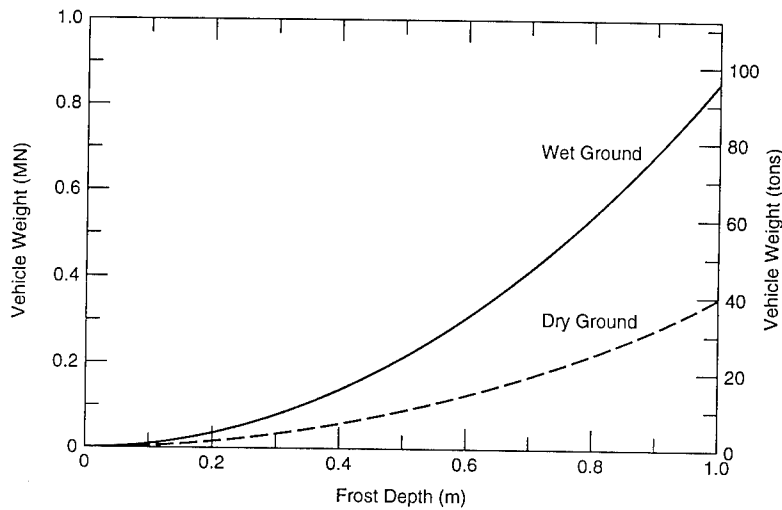

Figure 12. Vehicle bearing capacity of frozen ground.

or thawing are assumed to be the same as for unfrozen conditions.

### Bearing capacity of freezing ground

Vehicle operation on freezing ground is characterized by the ability of the ground to fully support the vehicle. For unfrozen soils that are not extremely difficult to traverse, the presence of 5 cm of frost at the surface will usually allow unlimited cross country operation (Richmond 1991). Terrain that is normally untrafficable may require a substantial frost layer before vehicle operations are possible.

Certainly "soft" terrain stands to gain considerable strength upon freezing. For example, the compressive strength of frozen peat can be 350–400 times its unfrozen strength (MacFarlane 1968), making it possible to operate vehicles in peat areas as long as they are frozen. We use a definition of soft terrain based on the Cone Index, where values of 50 or less constitute very weak soils. Although cone penetration is not particularly applicable to measuring the strength of heavily vegetated terrain, it can serve as a gross assessment of the bearing capacity of the ground, disregarding the strength of root systems. Niemi and Bayer (1970) have documented Cone Index values of 50 or less for peat or muskeg.

To arrive at predictions of bearing capacity for frozen ground over a soft substrate, we utilize published guidelines for forestry operations on peatlands (Rummukainen 1984) (Table 1). The equivalent loads are estimates of the gross vehicle weight. From these guidelines the following equations were generated to represent the limits for a break-

through failure of a frozen layer that is less than 0.5 m thick:

$$P = 0.35 t^2 \quad \text{for dry conditions} \quad (14)$$

$$P = 0.86 t^2 \quad \text{for wet conditions} \quad (15)$$

where  $P$  is the maximum recommended load in MN and  $t$  is the frost depth in meters. The wet condition represents saturated peat. In the dry con-

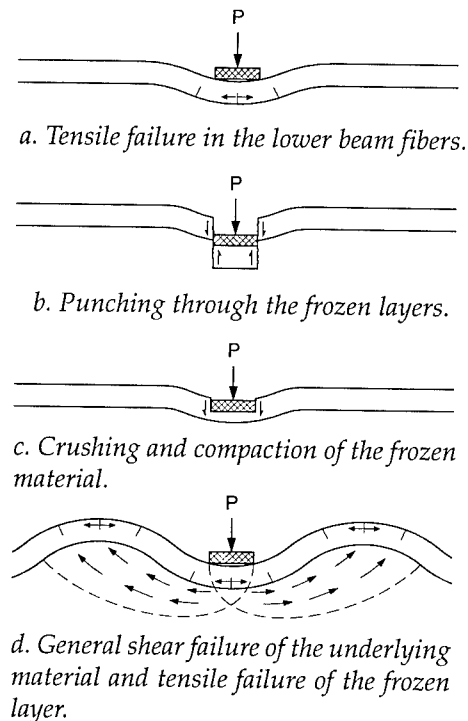

Figure 13. Bearing failure modes for a shallow frozen layer over soft ground.

Table 1. Bearing strength of frozen peatland. (After Rummakainen 1984.)

Thickness of frozen peat layer (m)		Bearing capacity	Approx. equiv. load	
Dry top peat layer	Wet top peat layer		(MN)	(lbf)
0.10	0.05	Will bear a horse	0.00445–0.008	1000–1800
0.15–0.20	0.10	Will bear 6-ton horse-drawn sled traffic	0.05	12,000
0.20–0.35	0.15–0.25	Will bear empty 4-ton truck	0.036	8000
0.35–0.50	0.25–0.40	Will bear 10-ton truck traffic	0.09	20,000

dition the peat is less than saturated and has usually been drained. (A frost depth of 0.5 m will prevent breakthrough failure of most vehicles.) Equations 14 and 15 are shown schematically in Figure 12 in terms of the frost thickness necessary to support different vehicle classes (vehicle class is approximately the vehicle weight in tons).

Mobility of heavy equipment may be limited by localized crushing failure of the surface material, particularly for the dry conditions (Fig. 13) (Shoop, in prep.). Therefore, the prediction equation for dry conditions, where surface crushing is likely, is not applicable for vehicles with high ground pressure. We recommend that the dry equation be used for all tracked vehicles and wheeled vehicles weighing less than 12 tons.

The predictive formulas are based on a best-fit equation for the wheeled vehicles, and they overestimate the frost thickness necessary for the sled (Table 1). Thus, our load support predictions will be conservative for vehicles with running gear that distributes load uniformly (e.g. tensioned tracks, numerous road wheels, skis).

These equations can also be applied to frozen ground other than peat. Once frozen, the strength of ground depends primarily on its ice content, its density and its temperature. The time-dependent compressive strength of frozen peat is similar to that of frozen mineral soils (MacFarlane 1968) and falls within the range of frozen silt or clay (Shoop, in prep.).

Very few data exist for vehicle traction on frozen ground. In general, frozen ground enhances mobility and traction. Exceptions are if the ground has a very high ice content or if the temperature is near melting. In these cases traction may be reduced because of the slipperiness of the surface and may be closer to the level of traction experienced on ice

rather than that for the soil alone. However, since we have no data to confirm this, no algorithm is implemented to account for this effect.

#### Effect of thawing conditions on vehicle performance

Thawing ground causes problems for vehicle mobility when it is associated with thaw weakening of the soil. During thaw, otherwise freely draining soils can become saturated because drainage is reduced by the underlying, nearly impermeable frozen layer. Vehicle travel is then restricted or impossible, and traffic can cause environmental damage (torn vegetation, mass soil flow and rutting, and subsequent erosion of sediments).

To predict traction and resistance in thawing soils, we start from either measured or predicted vehicle performance for the same soil at a temperate state. Adjustments are made to compensate for the significant loss of shear strength in a wet, thawing soil (resulting in a loss of traction) and the greater vehicle sinkage in the thaw-weakened soil (causing an increase in motion resistance). Using established methods for predicting traction and motion resistance for unfrozen soil (in this case, models developed by WES), we apply multipliers to reduce traction and increase motion resistance as the result of the thawing condition:

$$T_{\text{thaw}} = f T_{\text{gross}} \quad (16)$$

$$R_{\text{thaw}} = g R_{\text{terrain}} \quad (17)$$

where  $T_{\text{thaw}}$  = gross traction in the thawing soil  
 $R_{\text{thaw}}$  = terrain motion resistance in the thawing soil

$f$  = traction reduction multiplier  
 $g$  = motion resistance multiplier

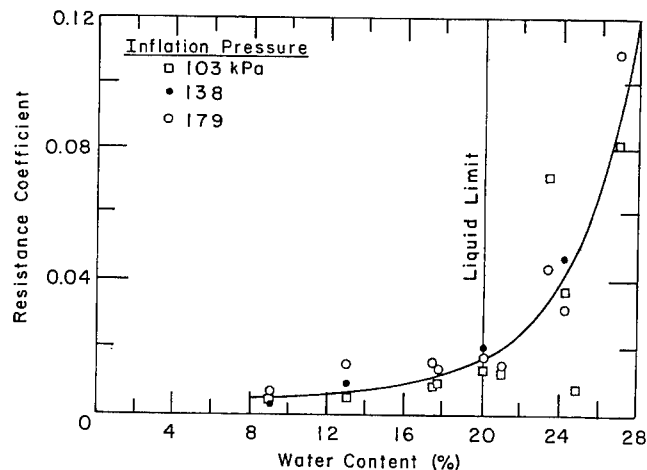
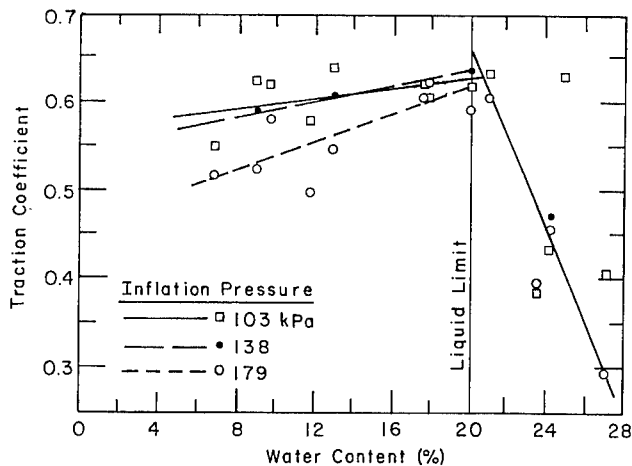

Figure 14. Traction coefficient and resistance coefficient vs. water content. Below the liquid limit, traction is a function of applied stress as reflected in tire inflation pressure. The net tractive coefficient decreases and the motion resistance coefficient increases for soil water contents above the liquid limit.

$R_{\text{terrain}}$  = terrain resistance for the unfrozen soil.

The multipliers are defined based on the measurements of vehicle performance on thawing soil reported in Shoop (1990, 1993c). The experiments were performed using an instrumented vehicle to measure traction and motion resistance on a wide variety of thawing conditions for a fine-grained sand. The experimental variables were soil thaw depth, moisture content, density and applied stress (tire inflation pressure).

The multipliers  $f$  and  $g$  vary with soil type, wetness, contact stress and thaw depth. Traction and motion resistance vary with the wetness of the thawed soil layer as shown in Figure 14. At lower water contents the traction coefficient depends on the tire contact stress. At high soil moisture (above the liquid limit), traction drops rapidly, and the contact stress has no noticeable effect. Motion resistance increases considerably at soil moistures above the liquid limit, and the effect of tire inflation pressure was negligible for the conditions tested.

The effect of the depth of thaw can be seen clearly when the data are grouped according to the wetness of the thawed layer (Fig. 15). The degree of wetness in the thawed layer is defined in Table 2. For both traction and motion resistance, the "wet" conditions are the most critical. When the soil is "moist," the soil strength is near optimum, and much of its strength is retained during the thaw cycle. Thus, for moist soils the thawing layer is strong enough that traction and motion

Table 2. Soil wetness descriptions.

Soil wetness	Water content (%)	Saturation (%)
wet*	23-27	83-100
moist	17-21	77-82
dry†	6-13	23-59

\* Nearly saturated and above the liquid limit.

† Below the specific retention of the soil.

resistance are nearly constant for all thaw depths  $S$ . For "dry" soils the thawing has a small effect on the overall soil strength, and traction is a function of both thaw depth and applied stress. Since this function has not yet been defined, we currently use an interim value of 1. For "dry" soils the effect of thawing on motion resistance is negligible.

The following expressions define the multipliers  $f$  and  $g$  in eq 16 and 17:

Traction:

Wet soils

$$f = 1.0 \quad S \leq 2.5 \text{ cm} \quad (18)$$

$$f = 2.379 (1/S^2) + 0.619 \quad 2.5 < S < 15 \quad (19)$$

$$f = 0.63 \quad 15 \leq S \quad (20)$$

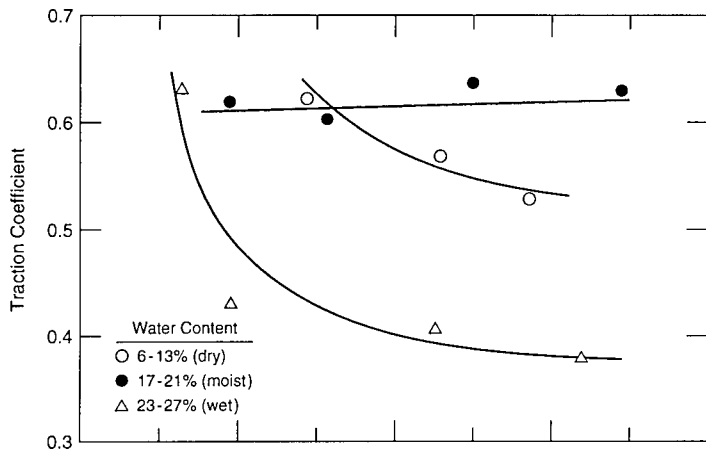

a. Traction coefficient vs. thaw depth.

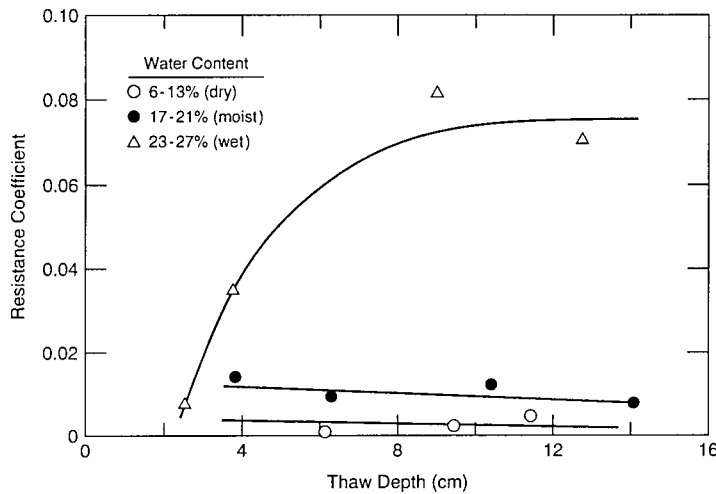

b. Resistance coefficient vs. thaw depth.

Figure 15. Effect of soil thaw depth on net traction and motion resistance coefficients as a function of soil moisture content.

Moist soils  
 $f = 1.0$  (21)

Dry soils  
 $f = 1.0$ . (22)

Motion resistance:

Wet soils  
 $g = 1.0$   $S \leq 2.5$  cm (23)

$g = 2.883 S - 6.056$   $2.5 < S < 4$  (24)

$g = -0.22 S^2 + 3.54 S - 5.24$   $4 \leq S \leq 8$  (25)

$g = 0.225 S + 7.2167$   $8 < S < 12$  (26)

$g = 10.00$   $12 \leq S$  (27)

Moist or dry soils  
 $g = 1.0$ . (28)

These equations are based on data obtained using an instrumented Jeep Cherokee (gross vehicle weight of 5600 lb.) equipped with light-truck, all-season, radial tires at a variety of tire inflation pressures (Shoop et al. 1993). For very heavy vehicles and for tracked vehicles, the critical thaw depth will change because of the larger and deeper volume affected by the applied stress. Because of the lack of effect of tire inflation pressure (contact pressure) for the most critical conditions (wet), the proposed relationships can be applied to a wide variety of vehicles with the understanding that there are no experimental data to validate the results. This aspect will be addressed in future studies.

The traction relationships are based on the optimum available traction, obtained by taking an average of the top 20% of the traction curve. The relative slip values and traction curve shapes were not evaluated.

Because these relationships were derived from tests on a non-plastic fine sand (unified soil classification SM) (Fig. 16), and limited tests on other sandy soils indicate the same general trends, we feel confident applying them to the following soil types:

SW: Well-graded sands, gravelly sands, little or no fines

SP: Poorly graded sands, gravelly sands, little or no fines

SM: Silty sands, sand and silt mixtures.

It is also reasonable to extrapolate beyond the range of test soils to other soils of similar mechanical behavior, such as other sands (SC), gravels (GW, GP, GM, GC) and silts (ML). We don't advise that they be applied to clayey soils or highly plastic soils since the behavior of the soil, and therefore its influence on traction and motion resistance, is likely to be quite different. When thaw-

ing conditions are encountered in clays and medium- or high-plasticity soils, we recommend that algorithms designed to treat surface slipperiness (Willoughby et al. 1991) be implemented in future versions of NRMM/CAMMS. Continuing research is aimed at completing the definition of  $f$  and  $g$  for more soil types and wetness conditions.

### SPEED MADE GOOD

The time to get from one point to another, or speed made good, is a function of many vehicle/operator and terrain/environment variables. Some reduction in speed occurs as a wheel or track slips. Making the assumptions that

- For a vehicle moving at a constant velocity on level terrain the traction generated must equal the total motion resistance,

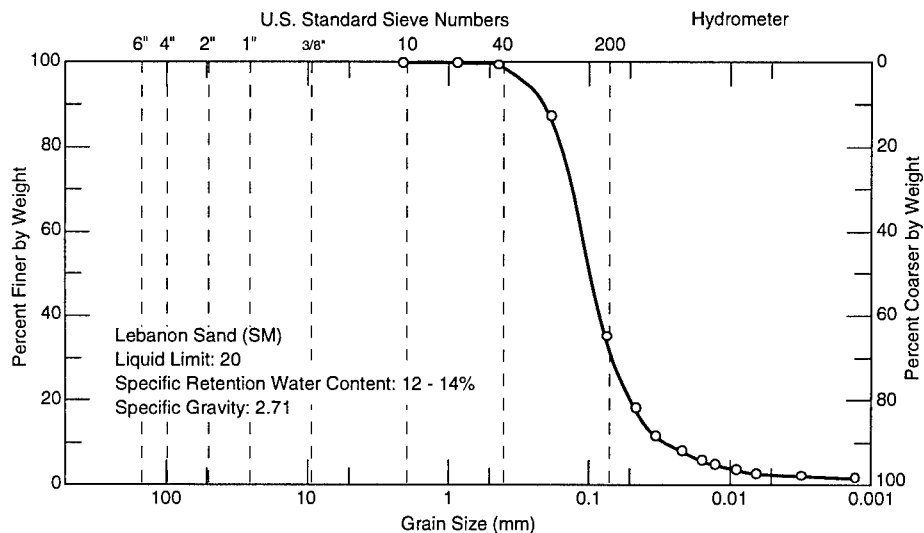

Cobbles	Gravel		Sand			Silt or Clay
	Coarse	Fine	Coarse	Medium	Fine	

a. Grain size distribution.

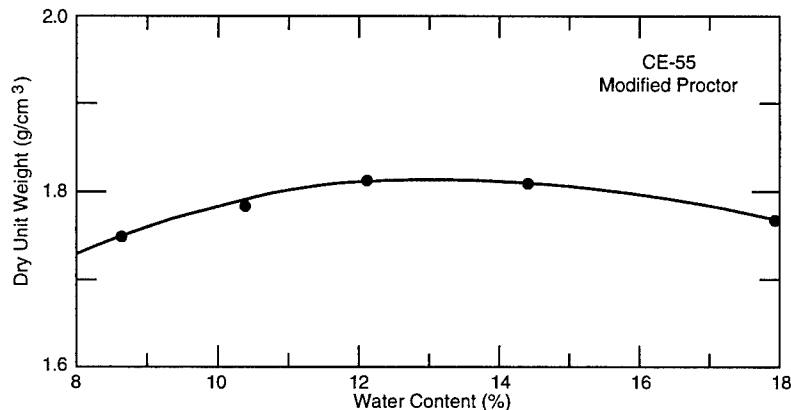

b. Soil compaction curve.

Figure 16. Characteristics of Lebanon sand.

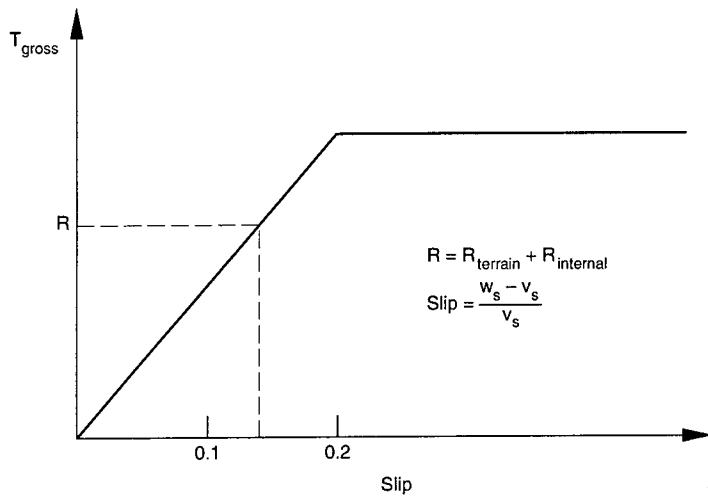

Figure 17. Idealized traction-slip curve in snow.

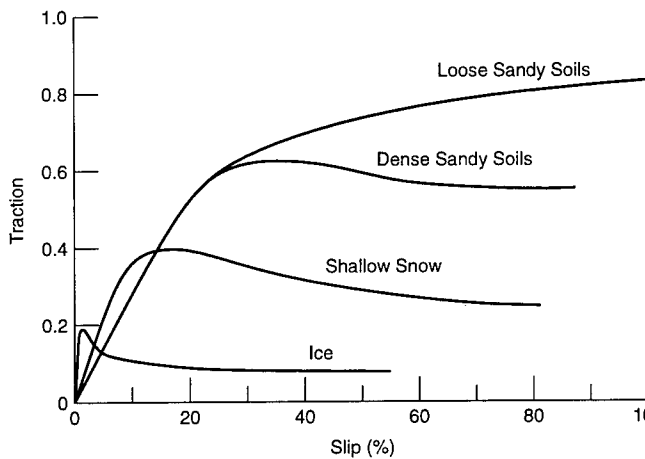

Figure 18. Generalized traction-slip curves for different surface materials.

- The maximum traction in snow occurs at about 20% slip, and
  - The traction-slip curve is nearly linear between 0 and 20% slip (Fig. 17),
- we claim that the slip when operating in snow can be calculated from the following equation:

$$Slip_{snow} = \frac{0.2(R_{terrain} + R_{internal})}{T_{gross}} \quad (29)$$

for  $T_{gross} \geq R_{terrain} + R_{internal}$ .

Once the slip has been calculated, the estimated vehicle velocity can be calculated using the definition for slip:

$$V_s = W_s \frac{1}{Slip_{snow} + 1} \quad (30)$$

where  $V_s$  and  $W_s$  are the vehicle and wheel speeds,

respectively. We recommend that this velocity correction be applied before other effects are taken into account. Generalized traction-slip curves for different materials are shown in Figure 18. These variations will need to be considered when or if the full traction curves are incorporated into future mobility models.

#### INTERNAL MOTION RESISTANCE

Internal motion resistance, as mentioned earlier, is the force caused by friction within the vehicle (tire deformation, friction in driveline components, etc.). We use the values for  $R_{internal}$  of wheeled and tracked vehicles as tabulated by Ahlvin and Haley (1992). These values (Table 3) are in coefficient form (the ratio of resistance force to wheel or track weight).

**Table 3. Internal motion resistance coefficients.**

$R_{internal}$		Surface
Wheeled	Tracked	
0.0150	0.0375	Superhighways and primary roads and ice
0.0250	0.0450	Secondary roads
0.0175	0.0525	Trails and cross country ( $P_{fg}^* \geq 4.0$ )
0.0150	0.0525	Trails and cross country ( $P_{fg} < 4.0$ )

\*  $P_{fg} = w / (nbr)$ , in psi, where,  $w$  is the weight on an axle,  $n$  is the number of wheels on an axle,  $b$  is the wheel width and  $r$  is the wheel radius.

## SLOPES

The main effect of slopes is the redistribution of the force of gravity on the vehicle body forces (Yong et al. 1984). This redistribution is seen as an additional resistance term due to gravity and a reduction of the normal load on each wheel or track assembly. Richmond (1993) examined this approach using the traction and resistance equations for snow presented earlier and obtained good results when compared with go/no-go tests on slopes. The effect of slopes on traction is implemented by multiplying the normal load on a wheel or track by the cosine of the slope angle. The effect on resistance is implemented by adding a resistance term due to gravity, which is equal to the gross vehicle weight times the sine of the slope angle, to  $R_{terrain}$ .

## SUMMARY AND RECOMMENDATIONS

The algorithms, rationale and data sources for what we call the Cold Regions Mobility Model have been presented. These algorithms are primarily empirical in nature and rely on relatively simple terrain measurements. Appendix A contains a stand-alone FORTRAN code of the Cold Regions Mobility Model (CRM-1.F); sample data files and output are presented.

We did not address the accuracy of the algorithms in this report; the reports in which these algorithms were initially developed discuss this issue somewhat. Future work will examine improvements in the algorithms and the overall accuracy with regard to speed made good and go/no-go predictions.

Because this is an empirically based model, and because mobility is a continuing area of interest to the U.S. Army, improvements and expansion of the model are to be expected. In the process of preparing this report a number of areas needing improvement were identified. For mobility/trafficability analysis over snow-covered areas, the following need further research: motion resistance in shallow snow, deep snow trafficability, and snow over a soft soil with large sinkage values. For operations on ice the effects of temperature and traction aids needs further study. In freezing/thawing soils further tests with heavy vehicles are required, the types of soils investigated need to be expanded, and tracked vehicles need to be evaluated.

## LITERATURE CITED

- Abele, G.** (1990) Snow roads and runways. USA Cold Regions Research and Engineering Laboratory, Monograph 90-3.
- Ahlvin, R. and P. Haley** (1992) NATO reference mobility model edition II, User's guide, Volume I (NRMM II). USA Waterways Experiment Station, Technical Report GL-92-19.
- Blaisdell, G.L.** (1984) Winter traction aids for wheeled vehicles. In *Proceedings of the 1984 Army Science Conference, 19-21 June 1984, West Point, New York*.
- Blaisdell, G.L. and S. Borland** (1992) Braking traction on sanded ice at low slip rates. Report prepared for Federal Aviation Administration, Washington D.C., by USA Cold Regions Research and Engineering Laboratory.
- Blaisdell, G.L., P.W. Richmond, S.A. Shoop, C. Green and R.G. Alger** (1990) Wheels and tracks in snow: Validation study of the CRREL shallow snow mobility model. USA Cold Regions Research and Engineering Laboratory, CRREL Report 90-9.
- Clark, S.K.** (1982) Mechanics of pneumatic tires. U.S. Department of Transportation. Washington, D.C.: U.S. Government Printing Office.
- Falls, T.C., C.D. Butler, B.T. Webb, J.L. Williamson and A. Chase** (1989) *A User's Guide for CAMMS Version 2.0*.
- MacFarlane, I.C.** (1968) Strength and deformation tests on frozen peat. In *Proceedings of the Third International Peat Congress, Quebec, Canada, August 18-23, 1968*, p. 143-149.
- Niemi, E.W. and R. Bayer** (1970) Analytical prediction of vehicle mobility on muskeg. U.S. Army Tank Automotive Command, Warren, Michigan,

TACOM Technical Report No. 11108 (LL 140) (AD 730792).

**Richmond, P.W.** (1991) Notes for cold weather military operations. USA Cold Regions Research and Engineering Laboratory, Special Report 19-30 (with excerpts from US Army Field Manual FM 90-13/FM 7-26, *Ice Bridging*, p. B-20).

**Richmond, P.W.** (1993) Predicting vehicle mobility on snow covered slopes. In *Proceedings of the First International Conference on Winter Vehicle Mobility, June 1991, Santa Barbara, California* (G.L. Blaisdell, Ed.). USA Cold Regions Research and Engineering Laboratory, Special Report 93-17.

**Richmond, P.W.** (in prep.) The motion resistance of wheeled vehicles in snow. USA Cold Regions Research and Engineering Laboratory, CRREL Report.

**Richmond, P.W., G.L. Blaisdell and C.E. Green** (1990) Wheels and tracks in snow: Second validation study of the CRREL shallow snow mobility model. USA Cold Regions Research and Engineering Laboratory, CRREL Report 90-13.

**Rummukainen, A.** (1984) Peatland properties and their evaluation for wood harvesting. Final Report for "Harvesting on Peatlands," a research project of the Nordic Research Council on Forest Operations (NSR), 1977-1983, University of Helsinki, Department of Logging and Utilization of Forest Products, Research Notes No. 45.

**Shapiro, L.H., J.B. Johnson, M. Sturm and G.L. Blaisdell** (in prep.) Snow mechanics: Review of the state of knowledge and applications. USA Cold Regions Research and Engineering Laboratory, CRREL Report.

**Shoop, S.A.** (1990) Mechanisms controlling vehicle mobility on a thawing soil. In *Proceedings of the 10th International Conference of the International Society of Terrain Vehicle Systems, August 1990, Kobe, Japan*, vol. I, p. 301-312.

**Shoop, S.A.** (1993a) Three approaches to winter traction testing. USA Cold Regions Research and Engineering Laboratory, CRREL Report 93-9.

**Shoop, S.A.** (1993b) Terrain characterization for trafficability. USA Cold Regions Research and Engineering Laboratory, CRREL Report 93-6.

**Shoop, S.A.** (1993c) Effect of soil thawing on off-road vehicle traction. In *Proceedings, 6th International Permafrost Conference, July 1993, Beijing, China.*, vol. 1, p. 559-563. Submitted to *Journal of Terramechanics*.

**Shoop, S.A.** (in press) Vehicle bearing capacity of frozen ground. *Canadian Geotechnical Journal*, accepted for publication in June 1995.

**Shoop, S.A. and R. Alger** (1993) Snow characterization for traction testing: A survey of techniques used. In *Proceedings of the First International Conference on Winter Vehicle Mobility, June 1991, Santa Barbara, California* (G.L. Blaisdell, Ed.). USA Cold Regions Research and Engineering Laboratory, Special Report 93-17.

**Shoop, S.A., E. Berliner and S. Decato** (1993) An experimental method for vehicle mobility testing on freezing/thawing soil. In *Proceedings of the First International Conference on Winter Vehicle Mobility, June 1991, Santa Barbara, California* (G.L. Blaisdell, Ed.). USA Cold Regions Research and Engineering Laboratory, Special Report 93-17.

**Society of Mining Engineers** (1973) *SME Mining Engineering Handbook*. New York: Society of Mining Engineering of the American Institute of Mining, Metallurgical, and Petroleum Engineers, Inc.

**Yong, R.N., E.A. Fattahand and N. Skiadas** (1984) *Vehicle Traction Mechanics*. New York: Elsevier.

**Willoughby, W.E., R.A. Jones, C.D. Cothren, D.W. Moore, D.M. Rogillio, R.F. Unger and T.L. Prickett** (1991) Mobility in slippery soils and across gaps, Volume 1: Program summary. USA Waterways Experiment Station, Technical Report GL-91-2.

## APPENDIX A: COLD REGIONS MOBILITY MODEL CRM-1.F

### GENERAL

The program CRM-1.F is a FORTRAN code that calculates mobility parameters and factors that can be used to determine go/no-go conditions, drawbar pull, drawbar coefficient, gross traction, total resistance and slip due to traction on snow. For calculations on snow the required data are snow depth and density, slope, RCI if there is a soft soil underlying the snow, and vehicle data (described below). If the analysis involves only thawing or freezing soils, the model requires soil type, soil wetness (Table 2) and the frost or thaw depth. To calculate the frost depth needed to support a vehicle, the vehicle weight or class is needed.

The code consists of a main program and the following subroutines:

For snow calculations:

- vehdata – reads the vehicle data files for snow modeling
- snow – reads the snow and terrain data (interactively)
- pressure – calculates vehicle contact pressures
- density – calculates  $\rho_f$  and the vehicle sinkage
- rterrain – calculates the resistance due to the terrain
- hard – determines the internal resistance coefficient
- traction – calculates the gross traction
- totalsnow – calculates the ratio of vehicle to wheel speed, net traction and drawbar coefficients.

For thawing and freezing soil:

- soil – reads USCS soil type and soil wetness (interactively)
- trmult – calculates traction multipliers for thawing soils
- mrmult – calculates resistance multipliers for thawing soils
- thaw – writes traction and resistance multipliers to the screen
- freeze – models frozen soil bearing capacities for wet or dry soils.

### VEHICLE DATA FILES

CRM-1.F reads vehicle data files developed specifically for the Cold Regions Mobility Model to determine the mobility parameters of a specified vehicle operating in snow. No vehicle data file is required for the freezing-thawing soils subroutines. The program reads two types of data files: wheeled and tracked vehicle files. The data below are for the HMMWV, a wheeled vehicle.

The second line represents the type of vehicle. Wheeled vehicles are labeled as type 0, and tracked vehicles are type 1. Line 3 lists the number of axles. The number of wheels per axle is in line 5; as indicated, the HMMWV has two wheels for each axle. The axles are powered if the value for the axle power is 1; if the value is 0, the axle is not powered. Line 7 is the radius of each wheel. Line 8 is the maximum

<i>Line</i>	<i>Value</i>	<i>Data</i>	<i>FORTTRAN format code</i>	
1	Vehicle name	HMMWV	2a4	
2	Vehicle type	0	10i2	
3	No. of axles	2	i2	
4	Ground clearance, inches	15.75	f8.2	
5	No. wheels per axle	2	2	10i2
6	Axle power	1	1	10i2
7	Radius of each wheel (in.)	16.90	16.90	10f7.2
8	Width of each wheel (in.)	12.60	13.00	10f7.2
9	Load on each axle divided by the number of wheels (lb)	1625.00	2135.00	10f7.2
10	Tire contact area (in. <sup>2</sup> )	115.00	115.00	10f7.2
11	Unloaded section height and loaded tire deflection (in.)	9.0	1.2	*

deflected tire width. The contact area, line 10, is the hard surface contact area for a single tire on each axle. The unloaded section height is determined by the height of the tire without any load placed on it to cause a deflection. The loaded tire deflection is determined by calculating the deflection of the tire when a load is placed on it. Note that lines 8, 10 and 11 are functions of the tire inflation pressure.

For the tracked vehicles the data files are set up a little differently. The example below is for the M113.

<i>Line</i>	<i>Value</i>	<i>Data</i>	<i>FORTRAN format code</i>
1	Vehicle name	M113	2a4
2	Vehicle type	1	10i2
3	No. of track sets	1	i2
4	Width of the track (in.)	15.00	10f7.2
5	Length of the track (in.)	105.00	10f7.2
6	Gross vehicle weight (lb)	23401.00	f8.2
7	Ground clearance (in.)	16.93	f8.2
8	Entry angle (degrees)	21.00	10f7.2

The third line gives the number of track sets for the vehicle (the SUSV, a two-unit articulated vehicle has two track sets). The number of tracks per set is set to 2 in the program. The entry angle, although required, is not used; an average value of 26° for all tracked vehicles is specified in CRM-1.

## TERRAIN INPUT

Terrain data are input interactively through a series of menus. For a soils analysis the codes in Table A1 and Table 2 (wetness definitions) are used. Table A2 contains the input data and associated output for a freezing-thawing soils analysis. Sample input data and the resulting output are shown in Table A3 and A4 for thawing and freezing soils, respectively. For snow analysis the input data and corresponding output are in Table A5. Table A6 is a set of results for an analysis of oversnow mobility of the M113 and HMMWV (using the vehicle parameters stated in describing the vehicle data files), comparing each of the underlying surfaces and snow types.

**Table A2. Input and output of CRM-1 (Soils).**

**Table A1. Codes for different soil and terrain surface types used in CRM-1. These are the same surface codes used in CAMMS and NRMM.**

1	SW	11	OL
2	SP	12	OH
3	SM	13	WATER
4	SC	14	PAVEMENT
5	SMSC	15	ROCK
6	CL	16	GW
7	ML	17	GP
8	CLML	18	GM
9	CH	19	GC
10	MH	20	PT (peat)

<i>Input</i>	<i>Output</i>
<i>Thawing Soils</i>	
Soil type (Table A1)	<i>yields</i> [ Traction multiplier Resistance multiplier
Wetness (dry, moist, or wet)	
Wheeled or tracked vehicle	
Thaw depth (cm)	
<i>Freezing Soils</i>	
Wet or dry ground, plus	<i>yields</i> Max. vehicle weight and class supported <i>yields</i> Min. frost depth required <i>yields</i> Min. frost depth required <i>yields</i> Go/no-go
Frost depth (cm)	
Vehicle class	
Vehicle weight (lb)	
Frost depth and vehicle	

**Table A3. Traction and motion resistance multipliers for wheeled vehicles on thawing sandy soils.\***

Soil Type: SW	Wetness: Wet	Vehicle: Wheeled
Thaw depth (cm)	Traction multiplier	Resistance multiplier
1	1.0	1.0
2	1.0	1.0
3	0.88	2.6
4	0.77	5.4
5	0.73	6.96
6	0.68	8.1
8	0.66	9.0
10	0.64	9.5
12	0.636	9.9
15	0.63	10.0
20	0.63	10.0

\*The same multipliers are obtained (with warnings) for clayey soils and tracked vehicles. A multiplier of 1.0 is specified for rock, water and pavement and for all dry (with warning) or moist soils.

**Table A4. Vehicle weights supported by various frost depths.**

Frost depth (cm)	Weight on wet ground		Weight on dry ground	
	(MN)	(lb)	(MN)	(lb)
2	0.0003	77	0.0001	31
5	0.0022	483	0.0008	197
10	0.0086	1933	0.0035	787
15	0.0194	4350	0.0079	1770
20	0.0344	7734	0.0140	3147
30	0.0774	17401	0.0315	7082
40	0.1376	30935	0.0560	12590
50	0.2150	48336	0.0875	19672

**Table A5. Sample input and output of CRM-1 (snow).**

	Example				
	1	2	3	4	5
<i>Input</i>					
Modeling option*	1	1	1	3	4
Vehicle†	M113	M113	M113	M113	M113
Snow Base Code**	1	1	1	3	4
Snow depth (cm)	15	15	15	15	12
Snow type††	7	7	6	6	7
RCI	—***	—	—	—	—
Snow density (g/cm <sup>3</sup> )	0.2	0.2	—	—	0.2
Slope (degrees)	0.0	30.0	0.0	0.0	0.0
<i>Output</i>					
Vehicle speed/wheel speed	0.975	0	0.974	0.964	0.941
Rut depth††† (cm)	9.0	9.0	0.0	0.0	7.2
Gross traction (N)	44134.3	39207.1	29692.1	29692.1	16741.3
Total resistance (N)	5585.4	57631.6	3903.5	5464.8	5275.1
Drawbar (N)	38548.9	-18424.5	25788.6	24227.2	11466.2
Drawbar coefficient	0.370	-0.177	0.248	0.233	0.110

Notes

\*Modeling option 1 is snow analysis, 2 is freezing/thawing soils.

†Requires a vehicle data file name.

\*\*Snow base codes (the material underlying the snow):

- 1—superhighways/primary roads.
- 2—secondary roads.
- 3—off-road terrain/trails/strong frozen ground.
- 4—ice (if snow depth is <1.0 cm, then ice only).
- 5—unfrozen soil (requires RCI).

††Snow type:

- 6—disturbed (more than four vehicle passes or a prepared snow road).
- 7—undisturbed snow.

\*\*\*Input not required with the previous specified input.

†††Total vehicle sinkage.

Table A6. Terrain/vehicle data sets from CRM-1.

Vehicle: M113

IBASE	$V_s/W_s$	Rut depth (cm)	Gross traction (N)	Total resistance (N)	Drawbar (N)	Drawbar coefficient
<b>Snow Type: Undisturbed</b>						
<b>Snow Depth: 15 cm</b>						
		<b>Density:</b>	<b>0.2 Mg/m<sup>3</sup></b>	<b>Slope:</b>	<b>0.0°</b>	
1	0.975	9.0	44134.3	5585.5	38548.9	0.370
2	0.972	9.0	44134.3	6366.1	37768.2	0.362
3	0.968	9.0	44134.3	7146.8	36987.5	0.355
4	0.937	9.0	16741.3	5585.5	11155.9	0.107
5 (RCI=30)	0.965	14.1	44134.3	7996.6	36137.7	0.347
<b>Snow Depth: 20 cm</b>						
		<b>Density:</b>	<b>0.15 Mg/m<sup>3</sup></b>	<b>Slope:</b>	<b>10.0°</b>	
1	0.901	14.0	43581.8	23915.4	19666.4	0.188
<b>Snow Depth: 0.0</b>						
		<b>Density:</b>	<b>—</b>	<b>Slope:</b>	<b>0.0°</b>	
4	0.930	0.0	10409.2	3903.5	6505.8	0.063
<b>Snow Type: Disturbed</b>						
<b>Snow Depth: 15 cm</b>						
		<b>Density:</b>	<b>—</b>	<b>Slope:</b>	<b>0.0°</b>	
1	0.974	0.0	29692.1	3903.5	25788.6	0.248
2	0.969	0.0	29692.1	4684.2	25007.9	0.240
3	0.964	0.0	29692.1	5464.8	24227.2	0.234
4	0.974	0.0	29692.1	3903.5	25788.6	0.248
5 (RCI=20)	0.935	10.5	29692.1	10359.0	19333.0	0.186
<b>Snow Depth: 15 cm</b>						
		<b>Density:</b>	<b>—</b>	<b>Slope:</b>	<b>15.0°</b>	
1	0.0	0.0	28710.2	30844.5	-2134.4	-0.021
<b>Snow type: Undisturbed</b>						
<b>Snow depth: 15 cm</b>						
		<b>Density:</b>	<b>0.2 Mg/m<sup>3</sup></b>	<b>Slope:</b>	<b>0.0°</b>	
1	0.934	9.0	12318.2	4348.9	7969.3	0.238
2	0.929	9.0	12318.2	4683.4	7634.8	0.228
3	0.933	9.0	12318.2	4432.5	7885.7	0.236
4	0.866	9.0	5643.9	4348.9	1295.0	0.039
5 (RCI=30)	0.924	12.6	12318.2	5096.3	7221.9	0.216
<b>Snow Depth: 20 cm</b>						
		<b>Density:</b>	<b>0.15 Mg/m<sup>3</sup></b>	<b>Slope:</b>	<b>10.0°</b>	
1	0.859	14.0	12163.9	9965.6	2198.4	0.068
<b>Snow Depth: 0.0</b>						
		<b>Density:</b>	<b>—</b>	<b>Slope:</b>	<b>0.0°</b>	
4	0.971	0.0	3345.0	501.8	2843.3	0.085
<b>Snow Type: Disturbed</b>						
<b>Snow Depth: 15 cm</b>						
		<b>Density:</b>	<b>—</b>	<b>Slope:</b>	<b>0.0°</b>	
1	0.989	0.0	9316.0	501.8	8814.3	0.264
2	0.982	0.0	9316.0	836.3	8479.8	0.254
3	0.986	0.0	9316.0	858.4	8730.7	0.261
4	0.989	0.0	9316.0	501.8	8814.3	0.264
5 (RCI=20)	0.835	7.0	9316.0	9193.4	122.6	0.004
<b>Snow Depth: 15 cm</b>						
		<b>Density:</b>	<b>—</b>	<b>Slope:</b>	<b>15.0°</b>	
1	0.0	0.0	9008.0	9159.4	-151.4	-0.005

C CRM-1.f  
C 7 MARCH 1994

C THIS PROGRAM CALCULATES THE TRACTION AND MOTION RESISTANCE  
C OF WHEELED AND TRACKED VEHICLES OPERATING ON ICE, OR IN DEEP OR  
C SHALLOW SNOW OVER VARIOUS BASE MATERIALS AND THAWING SOILS

C PROGRAM BY:

C HEATHER BANKER  
C GEORGE BLAISDELL  
C PAUL RICHMOND  
C SALLY SHOOP  
C KAREN FARAN

```
common/m1/nwhls(10),rads(10),width(10),pload(10),area(10),aa(10)
common/m2/ip(10),pres1(10),tlength(10)
common/m5/iveh,nunits,pmax,gclear,gvw
common/m6/def,sec
common/m7/ibase,rci,idist,slope
```

```
1000 write(*,*)'choose an option:'
      write(*,*)'1 = snow modeling (snow or ice covered)'
      write(*,*)'2 = soils modeling (frozen or thawing soils)'
      read(*,*)input
```

C INITIALIZE VARIABLES

```
sumz=0.
zmax=0.
gvw=0.
rsnow=0.0
trsnow=0.
totalr=0.
totaldb=0.
```

```
if(input.eq.1)then
call vehdata
call snow(hsnow,sigma0)
call pressure
call density(hsnow,sigma0,sigmaf,zmax)
call rterrain(hsnow,sigma0,sigmaf,zmax,sumz,rsnow)
call hard(reshard)
call traction(hsnow,trsnow)
call totalsnow(rsnow,trsnow,reshard,hsnow,sigma0,sumz)
```

```
else
write(*,*)'what type of soil problem is this'
write(*,*)'1 = thawing soil'
write(*,*)'2 = frozen soil'
read(*,*)input
  if(input.eq.1)then
call soil(isoil,iwet)
call trmult(isoil,iwet,trmlt,zthaw,ivehs)
call mrtmult(zthaw,svalid,isoil,iwet,rmult,ivehs)
```

```

call thaw(trmlt,rmult,zsnow)
  else
call freeze(isoil)
  end if
end if

write(*,*)'enter y to run another condition'
read(*,300)ans
300 format (a1)

if ((ans.eq."Y") .or. (ans.eq."y")) then
goto 1000
end if

c call exit(0)
end

C #####

subroutine vehdata

C THIS SUBROUTINE READS DATA FROM THE VEHICLE DATA FILE

common/m1/nwhls(10),rads(10),width(10),pload(10),area(10),aa(10)
common/m2/ip(10),pres1(10),tlength(10)
common/m5/iveh,nunits,pmax,gclear,gvw
common/m6/def,sec

character*12 mfile

write(*,*)'enter the vehicle data file name'
read(*,10) mfile

open(21,status='old',file=mfile,form='formatted')

C READ IN VEHICLE DATA
read(21,100)title
read(21,110)iveh !WHEELED=0, TRACKED=1

if(iveh.eq.0) then

C READ WHEEL VEHICLE DATA - ENGLISH UNITS
read(21,115)nunits !NO. AXLES,
read(21,220)gclear !GROUND CLEARANCE
read(21,110)(nwhls(i),i=1,nunits) !NUMBER OF WHEELS PER AXLE
read(21,110)(ip(i),i=1,nunits) !AXLE, 0=NO POWER ,1=POWERED
read(21,120)(rads(i),i=1,nunits) !RADIUS OF EACH WHEEL, IN.
read(21,120)(width(i),i=1,nunits) !WIDTH OF EACH WHEEL, IN.
read(21,120)(pload(i),i=1,nunits) !LOAD ON EACH WHEEL, LBS.
read(21,120)(area(i),i=1,nunits) !TIRE CONTACT AREA, SQ. IN.
read(21,*)sec,def !UNLOADED SECTION HEIGHT, LOADED
TIRE DEFLECTION

```

C CALCULATE GVW FOR WHEELED VEHICLES

```
do i=1,nunits
  gvw=gvw+(pload(i)*nwhls(i))
end do
```

```
write(*,115)nunits
write(*,220)gclear
write(*,110)(nwhls(i),i=1,nunits)
write(*,110)(ip(i),i=1,nunits)
write(*,120)(rads(i),i=1,nunits)
write(*,120)(width(i),i=1,nunits)
write(*,120)(pload(i),i=1,nunits)
write(*,120)(area(i),i=1,nunits)
write(*,*)sec,def
write(*,*)gvw
```

else

C READ TRACK VEHICLE DATA - ENGLISH UNITS

```
read(21,215)nunits
read(21,120)(width(i),i=1,nunits)    !TRACK WIDTH
read(21,120)(tlength(i),i=1,nunits) !TRACK LENGTH
read(21,220)gvw                      !GROSS VEHICLE WEIGHT
read(21,220)gclear                   !GROUND CLEARANCE
read(21,120)(aa(i),i=1,nunits)      !ENTRY ANGLE
```

```
write(*,215)nunits
write(*,120)(width(i),i=1,nunits)
write(*,120)(tlength(i),i=1,nunits)
write(*,220)gvw
write(*,220)gclear
write(*,120)(aa(i),i=1,nunits)
```

end if

```
10  format(a12)
100 format(2a4)
110 format(10i2)
115 format(i2)
120 format(10f7.2)
130 format(f6.2,f6.3)
215 format(i2)
220 format(f10.2)
```

close(21)

```
return
end
```

```
C *****
subroutine snow(hsnow,sigma0)
```

C THIS SUBROUTINE READS IN SNOW AND TERRAIN DATA

common/m7/ibase,rci,idist,slope

C ENTER TERRAIN DATA

```
write(*,*)'enter snow base code:'
write(*,*)'1 = super highways/primary roads'
write(*,*)'2 = secondary roads'
write(*,*)'3 = off-road terrain/trails/strong frozen soil'
write(*,*)'4 = ice (if snow depth is < 1.0cm then ice only)'
write(*,*)'5 = unfrozen soil'
read(*,*) ibase

write(*,*)'input the snow depth (cm)'
read(*,*)hsnow

if ((ibase.ne.4).or.(hsnow .ge. 1.0)) then

write(*,*)'enter the type of snow'
write(*,*)'6 = disturbed snow (more than 4 vehicle passes)'
write(*,*)'7 = undisturbed snow'
read(*,*)idist

end if

if (ibase.eq.5) then
write(*,*)'input rating cone index of the soil'
write(*,*)'20 < RCI < 100'
read(*,*) rci
end if

if (idist.eq.6) then
if (sigma0.le.0.55) then
sigma0 = 0.55
end if
else
if ((ibase.ne. 4).or.(hsnow .ge. 1.0)) then
write(*,*)'input the snow density (g/cm**3)'
read(*,*)sigma0
end if
end if

write(*,*)'enter the angle of the slope (degrees)'
read(*,*)slope

return
end
```

C \*\*\*\*\*

subroutine pressure

C THIS SUBROUTINE CALCULATES THE CONTACT PRESSURE

```
common/m1/nwhls(10),rads(10),width(10),pload(10),area(10),aa(10)
common/m2/ip(10),pres1(10),tlength(10)
```

```

common/m5/iveh,nunits,pmax,gclear,gvw

if (iveh.eq.1) then

C CALCULATE VALUES FOR TRACKED VEHICLES
do i=1,nunits
nwhls(i)=2    !ALL TRACKED VEHICLES HAVE 2 TRACKS PER AXLE
ip(i)=1      !ALL TRACKS ARE DRIVEN
area(i)=width(i)*tlength(i)
pload(i)=gvw/nunits/nwhls(i)
pres1(i)=pload(i)/area(i)
c   write(*,*)'pressure',pres1(i)
end do

else

C CALCULATE GROUND CONTACT PRESSURES FOR WHEELED VEHICLES
do i=1,nunits
pres1(i)=pload(i)/area(i)
c   write(*,*)'pressure1',pres1(i)
end do
end if

C   CALCULATE THE MAXIMUM PRESSURE
pmax=pres1(1)
do i=1,nunits
if (pres1(i).gt.pmax) pmax=pres1(i)
end do

return
end

C *****
subroutine density(hsnow,sigma0,sigmaf,zmax)

C THIS SUBROUTINE CALCULATES THE FINAL DENSITY AND SINKAGE

common/m5/iveh,nunits,pmax,gclear,gvw

C COMPUTE FINAL DENSITY DATA
sigmaf=.5
if(pmax.gt.30.5) sigmaf=.55
if(pmax.gt.50.8) sigmaf=.60
if(pmax.gt.101.5) sigmaf=.65

C COMPUTE SINKAGE
zmax= hsnow * (1. - (sigma0/sigmaf))
if(zmax.lt.0.)zmax=0.

return
end

C *****
subroutine rterrain(hsnow,sigma0,sigmaf,zmax,sumz,rsnow)

```

C THIS SUBROUTINE CALCULATES TERRAIN RESISTANCE OF THE VEHICLE

```
common/m1/nwhls(10),rads(10),width(10),pload(10),area(10),aa(10)
common/m2/ip(10),pres1(10),tlength(10)
common/m5/iveh,nunits,pmax,gclear,gvw
common/m6/def,sec
common/m7/ibase,rci,idist,slope
```

```
dimension xl2(10),rres1(10)
```

C START LOOP FOR RESISTANCE

```
flag = 1.0
rsnow = 0.0
soilz = 0.0
```

```
do i=1,10
xl2(i)=0.0
rres1(i)=0.0
end do
```

```
i=1      !ALL RESISTANCE CALCULATIONS ARE BASED ON FIRST !
         !UNIT CHARACTERISTICS AND PMAX
```

C WHEELED VEHICLES

```
if (iveh.eq.0) then
```

C ACCT FOR WEAK SOIL BASE

```
if (ibase.eq.5) then
```

```
pn = 1.      !IS THE NUMBER OF PASSES THE VEHICLE MAKES
s = 0.05     !SLIP ASSUMMED CONSTANT FOR THIS CALC
```

C def IS THE LOADED TIRE DEFLECTION

C sec IS THE UNLOADED TIRE SECTION HEIGHT

```
soilz=(10.*rads(i)*pn**.5)/((rci*2.*rads(i)*width(i))/
&(pload(i)*(1.-def/sec)**(3./2.)*s**.2))**.5/3.)
if (soilz.lt.0.0) soilz=0.0
```

```
soilz = soilz*2.54
```

```
end if
```

```
sumz=zmax+soilz      !sumz IS IN cm
```

C RESISTANCE PARAMETER, WHEELED VEHICLES IN SNOW

```
xl2(i)=rads(i)*acos((rads(i)-(sumz/2.54))/rads(i)) !INCHES
```

```
xl2(i)=xl2(i)*2.54      !cm
```

```
c      write(*,*)'xl2',xl2,'rads',rads(i)
```

C ACCOUNT FOR TIRE CURVATURE/DEEP SNOW FLAG

```
radscm = rads(i)*2.54
```

```

if((sigma0.lt.0.15).and.(sumz.ge.radscm))flag = 1.5
if((sigma0.ge.0.15).and.(sumz.ge.(radscm*2./3.)))flag = 1.5
if((sigma0.ge.0.15).and.(sumz.ge.(radscm)))flag = 2.5

```

C GROUND CLEARANCE FLAG

```

if (sumz.ge. (gclear*2.54)) flag = flag+1.5

else

```

C TRACKED VEHICLE RESISTANCE  
C ACCOUNT FOR WEAK SOIL BASE

```

if(ibase.eq.5) then
pn = 1.      !IS THE NUMBER OF PASSES THE VEHICLE MAKES

soilz=tlength(i)*pn**.5*0.00443*
&exp((5.889*pload(i))/(rci*width(i)*tlength(i)))
soilz = soilz*2.54
end if
sumz=zmax+soilz  !cm

```

C RESISTANCE PARAMETER, TRACKED VEHICLES IN SNOW

```

aa(i)=26.0    !AN AVERAGE VALUE FOR NRMM
xl2(i)=(sumz/sin(aa(i)*3.14159265/180.))  !cm

```

C GROUND CLEARANCE, LOW (FLAG=2.0) OR HIGH (FLAG=4.0) DENSITY SNOW

```

if((sigma0.lt.0.15).and.(sumz.ge.(gclear*2.54))) flag = 2.5
if((sigma0.ge.0.15).and.(sumz.ge.(gclear*2.54))) flag = 4.0

end if

```

```

if (flag.gt.1.0) then

```

C DEEP SNOW WARNING

```

write(*,*)'*****'
write(*,*)
write(*,*)'A DEEP SNOW FLAG HAS BEEN SET,'
write(*,*)'CALCULATIONS ARE NOT VALIDATED.'
write(*,*)'FLAG = ', flag
write(*,*)
write(*,*)'*****'
end if

```

```

c   print *, rads(i)
    print *, xl2(i),sumz
    xl=xl2(i)
    w=width(i)*2.54      !CONVERT TO cm

```

```

rres1(i)=(68.1*(0.10*sigma0*xl*w)**0.914)*flag    !KG/M IN PARATHESISSES

```

```

c   write(*,*)'flag',flag,'rres1',rres1,'sigma0',sigma0
c   write(*,*)(0.10*sigma0*xl*w),xl,w,sigma0

```

```
rres1(i)=rres1(i)/4.4482 !CONVERT TO lbs
```

```
C ADD SLOPE TO RESISTANCE AND SUM RESISTANCE FOR WHOLE VEHICLE  
C UP TO 4 UNITS ONLY FOR WHEELED VEHICLE SNOW RESISTANCE,  
C 1 UNIT LIMIT FOR TRACKS
```

```
sloper=slope*3.14159265/180. !SLOPE IN RADIANS
```

```
if(iveh.eq.0)then  
do j=1,nunits  
rres1(j)=rres1(1)
```

```
if (j.gt.4) then  
rres1(j)=0.0  
end if
```

```
rsnow= rsnow+((rres1(j)+pload(j)*sin(sloper))*nwhls(j))
```

```
end do
```

```
else  
rsnow=rres1(1)*nwhls(1)+gvw*sin(sloper)  
end if
```

```
return  
end
```

```
C *****
```

```
subroutine hard(reshard)
```

```
common/m1/nwhls(10),rads(10),width(10),pload(10),area(10),aa(10)  
common/m2/ip(10),pres1(10),tlength(10)  
common/m5/iveh,nunits,pmax,gclear,gvw  
common/m6/def,sec  
common/m7/ibase,rci,idist,slope
```

```
dimension cpffg(10)
```

```
C CPFFG = F-G CONTACT PRESSURE FACTOR FOR EACH ELEMENT  
C W = WEIGHT BENEATH SUSPENSION ASSEMBLY (TRACK PAIR OR AXLE) IN LBS  
C RHARD = HARD SURFACE RESISTANCE COEFFICIENT
```

```
reshard = 0.0
```

```
C WHEELED VEHICLES
```

```
if(iveh.eq.0)then
```

```
do i = 1,nunits  
w = pload(i)*nwhls(i)  
cpffg(i) = w/(nwhls(i)*width(i)*rads(i))
```

```
if((ibase.eq.3).or.(ibase.eq.5))then  
if(cpffg(i).ge.4.0)then
```

```

    rhard = 0.0175
    else
    rhard = 0.015
    end if
    else if((ibase.eq.1).or.(ibase.eq.4))then
    rhard = 0.015
    else
    rhard = 0.025
    end if
    reshared = reshared +rhard*w
end do

```

C TRACKED VEHICLES

```

    else
    if((ibase.eq.3).or.(ibase.eq.5))then
    rhard = 0.0525
    else if((ibase.eq.1).or.(ibase.eq.4))then
    rhard = 0.0375
    else
    rhard = 0.045
    end if
    reshared = rhard*gvw !TOTAL HARD SURFACE RESISTANCE FOR TRACK
end if

    return
end

```

C \*\*\*\*\*

```

    subroutine traction(hsnow,trsnow)

```

C THIS ROUTINE CALCULATES THE TRACTION OF THE VEHICLE

```

    common/m1/nwhls(10),rads(10),width(10),pload(10),area(10),aa(10)
    common/m2/ip(10),pres1(10),tlength(10)
    common/m5/iveh,nunits,pmax,gclear,gvw
    common/m6/def,sec
    common/m7/ibase,rci,idist,slope

```

```

    dimension trcn1(10)

```

C TRACTION CALCULATION

```

    trsnow = 0.0
    do i = 1,nunits
    pr=pres1(i)*6.8948 ! KPA
    pr=pr*cos(slope*3.14159265/180.) ! ACCOUNT FOR SLOPE

```

C UNDISTURBED SNOW

```

    if(((ibase.eq.1).or.(ibase.eq.2).or.(ibase.eq.3).or.(ibase.eq.5))
    &.and.(idist.eq.7))then

    trcn1(i)=0.851*((pr)**0.823)
c    write(*,*)'area',area(i),'load',pload(i)
c    write(*,*)'pressure',pres1(i)

```

```

c      write(*,*)'pressure in kPa',pr
c      write (*,*)trcn1(i)
      end if

```

C HARD PACKED SNOW

```

      if (idist.eq.6) then

          if((ibase.eq.1).or.(ibase.eq.2).or.(ibase.eq.3))then
              trcn1(i)=0.321*(pr)**0.97
          end if

          if(ibase.eq.5)then
              trcn1(i)=0.321*(pr)**0.97
          end if
      end if

```

C SNOW ON ICE BASE

```

      if((ibase.eq.4).and.(idist.eq.7))then
          trcn1(i)=0.127*(pr)**1.06
      else if((ibase.eq.4).and.(idist.eq.6))then
          trcn1(i)=0.321*(pr)**0.97
      end if

```

C ICE SURFACE

```

      if ((ibase.eq.4).and.(hsnow.le.1.0))then
          trcn1(i)=0.1*pr
      end if

      trcn1(i)=(trcn1(i)/6.8948)*area(i)  !CONVERT TO lbs

```

C NON-DRIVEN WHEEL

```

      if(ip(i).eq.0) trcn1(i)=0.0

```

C SUM TRACTION FOR EACH ELEMENT

```

      trsnow = trsnow + trcn1(i)*nwhls(i)

```

```

      end do

```

```

      return
      end

```

C \*\*\*\*\*

```

      subroutine totalsnow(rsnow,trsnow,reshard,hsnow,sigma0,sumz)

```

```

      common/m1/nwhls(10),rads(10),width(10),pload(10),area(10),aa(10)
      common/m2/ip(10),pres1(10),tlength(10)
      common/m3/xl2(10),cpffg(10)
      common/m5/iveh,nunits,pmax,gclear,gvw
      common/m6/def,sec
      common/m7/ibase,rci,idist,slope

```

C TOTAL VEHICLE TRACTION AND RESISTANCE

```

      totalr = reshard + rsnow
      totaldb = trsnow - totalr

```

C SLIP DUE TO TRACTION

```
if (totalr.le.trsnow) then
  slipt = .2*totalr / trsnow
  slipw = 1./(slipt + 1.) !RATIO OF VEHICLE SPEED TO WHEEL SPEED
else
  slipw=0.0
end if
```

C WRITE TOTAL VEHICLE TRACTION AND RESISTANCE

```
write(*,210)hsnow,sigma0,slope
write(*,*)'ratio of vehicle speed to wheel speed: ',slipw
write(*,*)'  units are lbs:'
write(*,260)sumz,trsnow,totalr,totaldb
write(*,*)'  units are N:'
write(*,260)sumz,trsnow*4.4482,totalr*4.4482,totaldb*4.4482
write (*,*)'drawbar coefficient = ,(totaldb/gvw)
```

```
200 format(1x,a12)
210 format(/ 1x,"snow depth, cm.= ",f5.2,2x,"density, g/cc= ",f5.4,
& " slope= ",f6.2)
260 format(1x,"rut,cm.= ",f4.1,2x,"tr =",f8.1,2x,"rr= ",f8.1,
& 2x,"db= ",f8.1)

return
end
```

C \*\*\*\*\*

```
subroutine thaw(trmlt,rmult,zsnow)
```

```
C if(layer.eq.1.and.zsnow.lt.1.0/xcm2in)then
do i = 1, nunits
c   trmltn = (dowpb(i) + rtowpb(i))*trmlt
c   rtowpb(i) = rtowpb(i)*rmult
c   rtowt(i) = rtowt(i)*rmult
c   dowpb(i) = trmltn - rtowpb(i)
end do
C else
C write(*,*)'routine thaw is not implemented for:'
C if(layer.ne.1.)then
C   write(*,*)'critical depth > 6 in.'
C else
C   write(*,*)'snow cover > 1 cm'
C end if
C end if
write(*,*)'traction multiplier',trmlt
write(*,*)'motion resistance multiplier',rmult

C
return
end
```

C \*\*\*\*\*

```
subroutine trmult(isoil,iwet,trmlt,zthaw,ivehs)
c this subroutine calculates the traction multiplier
```

```
write(*,*)'are you using wheeled (0) or a tracked vehicle (1)'  
read(*,*)ivehs
```

```
write(*,*)'input the thaw depth (cm)'  
read(*,*)zthaw
```

```
trmlt = 1.  
if((iwet.eq.3).and.((isoil.lt.13).or.(isoil.gt.15)))then  
  if(zthaw.le.2.5)then  
    trmlt = trmlt  
    else if((zthaw.gt.2.5).and.(zthaw.lt.15.))then  
      trmlt = trmlt*(2.379*(1/zthaw**2.))+0.619  
    else if(zthaw.ge.15.)then  
      trmlt = 0.63*trmlt  
    end if  
  else if(iwet.eq.2) then  
    trmlt = 1.  
  else if(iwet.eq.1)then  
    write(*,*)'*****'  
    write(*,*)'for dry soils, the effect of thawing on traction is a '  
    write(*,*)'function of applied stress; these functions have not  
    write(*,*)'yet been developed so a multiplier of 1.0 is used'  
    write(*,*)'*****'  
    end if  
  if((isoil.ge.13).and.(isoil.le.15))then  
    trmlt = 1.  
    write(*,*)'*****'  
    write(*,*)'A multiplier of 1.0 is used for water, rock, or pavement'  
    write(*,*)'*****'  
    end if  
  if(((isoil.ge.6).and.(isoil.le.12)).or.(isoil.eq.20))then  
    write(*,*)'*****'  
    write(*,*)'calculations are based on sandy soils'  
    write(*,*)'*****'  
    end if  
  if(ivehs.eq.1)then  
    write(*,*)'*****'  
    write(*,*)'calculations are based on wheeled vehicles '  
    write(*,*)'*****'  
    end if  
  
  return  
end
```

```
C *****  
      subroutine mrtmult(zthaw,svalid,isoil,iwet,rmult,ivehs)  
c this subroutine calculates the motion resistance multiplier  
  rmult = 1.  
c  if(iwet.eq.3)then  
  if((iwet.eq.3).and.((isoil.lt.13).or.(isoil.gt.15)))then  
    if(zthaw.le.2.5)then  
      rmult = 1.  
    else if((zthaw.gt.2.5).and.(zthaw.lt.4.))then
```

```

    rmult = rmult*(2.883*zthaw - 6.056)
else if((zthaw.ge.4.)and.(zthaw.le.8.))then
    rmult = rmult*(-0.22*zthaw**2. + 3.54*zthaw - 5.24)
else if((zthaw.gt.8.)and.(zthaw.lt.12.))then
    rmult = rmult*(0.225*zthaw + 7.2167)
else if(zthaw.ge.12)then
    rmult = rmult*10.0
end if
end if

return
end

```

C \*\*\*\*\*

```

    subroutine soil(isoil,iwet)
c this subroutine asks the USCS soil type and wetness
    write(*,*)'choose an USCS soil type code:'
    write(*,*)' 1 = SW'
    write(*,*)' 2 = SP'
    write(*,*)' 3 = SM'
    write(*,*)' 4 = SC'
    write(*,*)' 5 = SMSC'
    write(*,*)' 6 = CL'
    write(*,*)' 7 = ML'
    write(*,*)' 8 = CLML'
    write(*,*)' 9 = CH'
    write(*,*)'10 = MH'
    write(*,*)'11 = OL'
    write(*,*)'12 = OH'
    write(*,*)'13 = WATER'
    write(*,*)'14 = PAVEMENT'
    write(*,*)'15 = ROCK'
    write(*,*)'16 = GW'
    write(*,*)'17 = GP'
    write(*,*)'18 = GM'
    write(*,*)'19 = GC'
    write(*,*)'20 = PT'
    read(*,*)isoil

    write(*,*)'input the soil wetness'
    write(*,*)' 1 = dry'
    write(*,*)' 2 = moist'
    write(*,*)' 3 = wet (water content is above liquid limit)'
    read(*,*)iwet

    return
end

```

C \*\*\*\*\*

```

    subroutine freeze

    write(*,*)'FROZEN GROUND MENU'
    write(*,*)'1 = input the frost depth'
    write(*,*)'2 = input the vehicle class'

```

```

write(*,*)'3 = input the vehicle weight (lb.)'
write(*,*)'4 = input frost depth and vehicle class or weight'
read(*,*)nput

```

```

write(*,*)'choose a soil condition'
write(*,*)'1 = wet'
write(*,*)'2 = dry'
read(*,*)cond

```

```

if(nput.eq.1)then
write(*,*)'input the frost depth (cm)'
read(*,*)fdepth
fdepth = fdepth/100.      !CONVERT TO METERS

```

C CALCULATE THE MAXIMUM LOAD THAT A SPECIFIED FROST DEPTH WILL HOLD

```

if(cond.eq.1)then
p = 0.86*fdepth**2.
else if(cond.eq.2)then
p = 0.35*fdepth**2.
end if
write(*,*)'maximum load that can travel on',fdepth,'m =',p,'MN'

```

c convert dimensions of p from MN to pounds

```

p=p/(4.448222e-6)
write(*,*)'maximum load that can travel on',fdepth,'m =',p,'pounds'
else if(nput.eq.2)then
write(*,*)'input the vehicle class'
read(*,*)vclass

```

C CALCULATE THE MINIMUM FROST DEPTH THAT WILL HOLD A SPECIFIED VEHICLE

```

if(cond.eq.1)then
fdepth = 10*(vclass)**.5
else if(cond.eq.2)then
fdepth = 16*(vclass)**.5
end if
fdepth = fdepth/100      !convert from cm to m
write(*,*)'minimum frost depth that can hold class',vclass,'= ',
& fdepth,'m'

```

```

else if(nput.eq.3)then
c write(*,*)'input the vehicle weight (MN)'
write(*,*)'input the vehicle weight (pounds)'
read(*,*)vwght
vwght=vwght*4.448222e-6      !convert to MN

```

C CALCULATE THE MINIMUM FROST DEPTH THAT WILL HOLD A SPECIFIED LOAD

```

if(cond.eq.1)then
c fdepth = (0.86/p)**.5
fdepth = (vwght/0.86)**.5
else if(cond.eq.2)then
c fdepth = (0.35/p)**.5
fdepth = (vwght/0.35)**.5
end if
write(*,*)'minimum frost depth that can hold',vwght,'MN =',fdepth,'m'

```

```

vwght=vwght/4.448222e-6      !convert to pounds
write(*,*)'minimum frost depth that can hold',vwght,'pounds =',
& fdepth,'m'

```

C CALCULATE THE GO/NO GO SITUATION OF BOTH VALUES INPUTTED  
C EITHER THE WEIGHT OR THE CLASS WILL BE READ

```

else if(nput.eq.4)then
  write(*,*)'input the frost depth (cm)'
  read(*,*)fdepth
  fdepth = fdepth/100.      !CONVERT TO METERS
  write(*,*)'are you using vehicle weight (1) or class (2)'
  read(*,*)ans
  if(ans.eq.1)then
c   write(*,*)'input the vehicle weight (MN)'
    write(*,*)'input the vehicle weight in pounds'
    read(*,*)vwght
    vwght=vwght*4.448222e-6
  if(cond.eq.1)then
  if(vwght.le.0.86*fdepth**2.)then
    write(*,*)'*****'
    write(*,*)'the ground can support this vehicle!'
    write(*,*)'*****'
  else
    write(*,*)'*****'
    write(*,*)'the ground can not support this vehicle!'
    write(*,*)'*****'
  end if
  else if(cond.eq.2)then
  if(vwght.le.0.35*fdepth**2.)then
    write(*,*)'*****'
    write(*,*)'the ground can support this vehicle!'
    write(*,*)'*****'
  else
    write(*,*)'*****'
    write(*,*)'the ground can not support this vehicle!'
    write(*,*)'*****'
  end if
  end if
  else if(ans.eq.2)then
    write(*,*)'input the vehicle class (tons)'
    read(*,*)vclass
  if(cond.eq.1)then
  if(fdepth.ge.10.*(vclass)**.5)then
    write(*,*)'*****'
    write(*,*)'the ground can support this vehicle!'
    write(*,*)'*****'
  else
    write(*,*)'*****'
    write(*,*)'the ground can not support this vehicle!'
    write(*,*)'*****'
  end if
  else if(cond.eq.2)then
  if(fdepth.ge.16.*(vclass)**.5)then

```

```

write(*,*)'*****'
write(*,*)'the ground can support this vehicle!'
write(*,*)'*****'
else
write(*,*)'*****'
write(*,*)'the ground can not support this vehicle!'
write(*,*)'*****'
end if
end if
end if
end if
if(fdepth.ge.0.5)then
write(*,*)'*****'
write(*,*)'0.5m frost will prevent breakthrough of most heavy'
write(*,*)'equipment but mobility may be limited by crushing'
write(*,*)'failure of the surface material.'
write(*,*)'*****'
end if

return
end

```

# APPENDIX B. FORTRAN CODE USING NRMM/CAMMS VARIABLES AND FORMAT

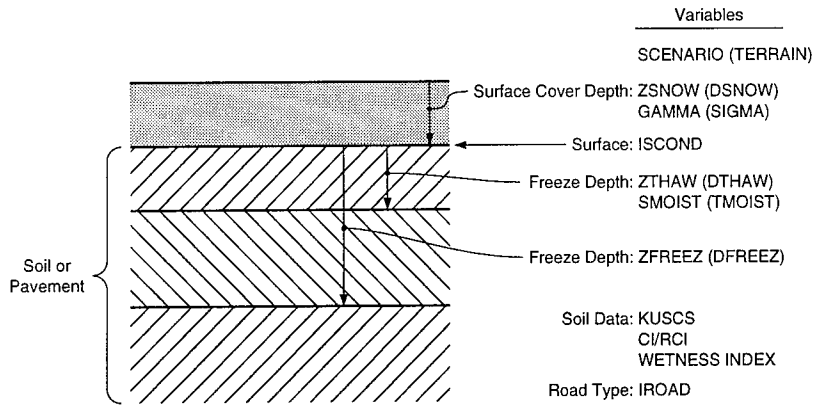

Figure B1. Cold regions variable description for NRMM II ver. 2.5.0.

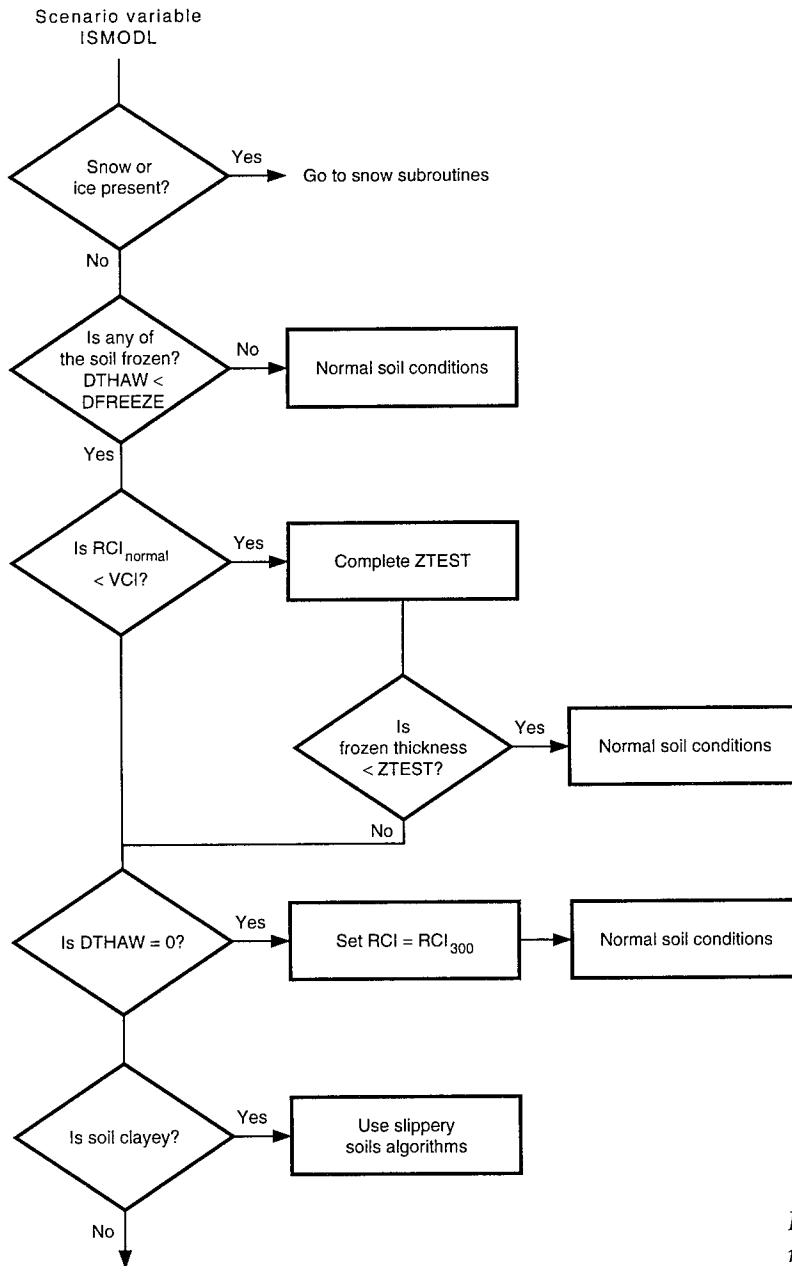

Figure B2. Logic in the cold regions module of NRMM II ver. 2.5.0.

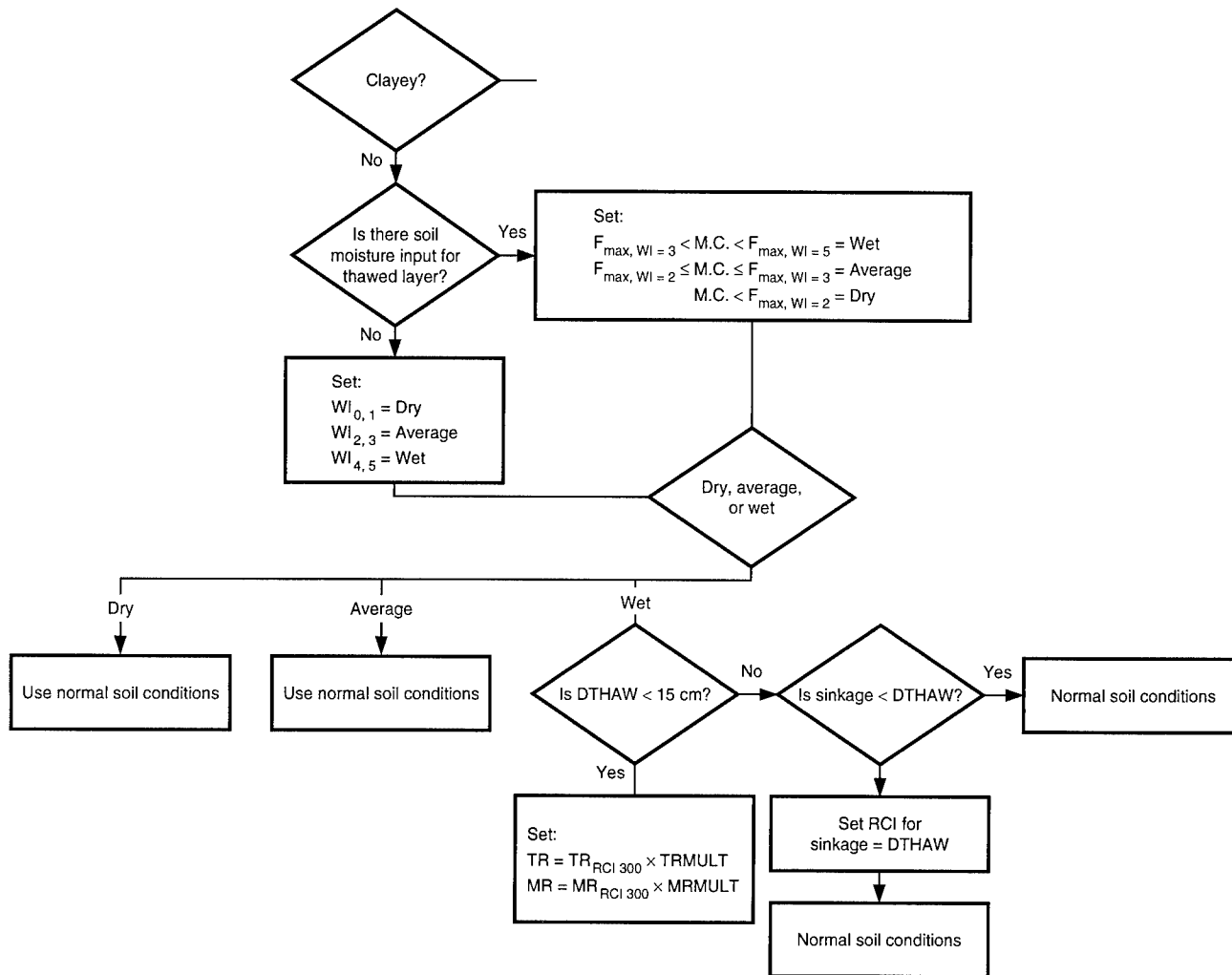

Figure B2 (cont'd). Logic in the cold regions module of NRMM II ver. 2.5.0.

```

C CRLSNOW COLD REGIONS MODEL 28 March 94
C*****
C      *
C C R L S N O W *
C      *
C*****
C LOGICAL FUNCTION CRLSNOW()
C
C 18 Jun 92   Implemented in CAMMS/NRMM by R.B.Ahlvin
C 15 Mar 94   Paul Richmond
C 28 Mar 94   Karen Faran
C
C Inputs:
C Common /DERIVE/
C JPSI          Current deflection scenario index
C Common /PREP/
C GCA(NAMBLY,NJPSI)  Ground contact area for each traction element
C Common /TERRAN/
  
```

C DSNOW            Depth of snow cover (0=no snow) [in]  
 C DTHAW            Depth of thawing [in]  
 C ITSURF            Hard surface condition: [1]=dry, 2=wet, 3=ice-covered  
 C SIGMA            Density of snow [gm/cm<sup>3</sup>]  
 C Common /VEHICL/  
 C CL                Minimum ground clearance [in]  
 C DIAW(NAMBLY)    Undelected tire diameter, each assembly [in]  
 C NAMBLY            #traction element assemblies (axles and tracks)  
 C NVEH(NAMBLY)    Vehicle traction assembly type: 0=tracked, 1=wheeled  
 C NWHL(NAMBLY)    #tires on each wheeled assembly  
 C SECTW(NAMBLY)    Tire nominal section width [in]  
 C TRAKLN(NAMBLY)    Length of track on ground [in]  
 C TRAKWD(NAMBLY)    Track width (one side) for each tracked assembly [in]  
 C WGHT(NAMBLY)    Weight on each vehicle assembly [lbs]  
 C WT(NAMBLY)        Tread widths, each assembly (center to center) [in]  
 C WTE(NAMBLY)     Min. width between traction elements [in]  
 C  
 C Outputs:  
 C Common /DERIVE/  
 C DOWPB(NAMBLY)    Drawbar coefficient for each assembly  
 C RTOWPB(NAMBLY)    Motion res. coef., powered or braked, each element  
 C RTOWT(NAMBLY)    Motion res. coef., towed, each element  
 C Common /TPREP/  
 C IBASE            CRREL model base code:  
 C                    0 = unassigned  
 C                    1 = super-highway, primary road  
 C                    2 = secondary road  
 C                    3 = off-road & trail  
 C                    4 = Ice  
 C                    5 = soft soil  
 C  
 C External:  
 C RHARD            Function to return hard surface resistance for snow  
 C  
 C Internal:  
 C AA                Track approach angle (rad)  
 C AREA1            Contact area single traction element (in<sup>2</sup>)  
 C DEFSEC            1 minus-the deflected radius divided by the section width (in)  
 C FACT            Conversion factor for N/cm<sup>2</sup> to psi  
 C FLAG            Deep snow multiplier  
 C I                 Traction assembly index  
 C IBASE            Terrain type flag as follows:  
 C                    1 = road  
 C                    2 = frozen or strong soil  
 C                    3 = unfrozen soil (RCI<100)  
 C                    4 = ice  
 C PMAX            Maximum suspension element contact pressure (psi)  
 C PN                Number of vehicle passes  
 C PR1KPA            Contact pressure of single traction element Kilo-Pascals  
 C PRES1            Contact pressure of single traction element (psi)  
 C RADSI            Radius of current wheeled traction element (in)  
 C RRES1            Motion resistance from snow (lb)  
 C RTOW            Temporary resistance coefficient

C SIGMA0 Input snow specific gravity  
 C SIGMAF Final snow specific gravity  
 C SLIP Vehicle wheel slip  
 C SOILZ Sinkage in soil of current traction element (in)  
 C SUMZ Total vehicle sinkage  
 C TFOW Temporary traction coefficient  
 C TRCN1 Maximum traction for i-th tire (lb)  
 C XL2 Snow contact length for i-th suspension element (in)  
 C XNWORT Number of wheels or tracks on suspension assembly  
 C XWID1 Width of one traction element (in)  
 C WGHT1 Weight on single traction element (wheel or track) (lb)  
 C X2KPA Conversion factor from psi to KPA  
 C ZMAX Maximum sinkage in snow (in)  
 C

IMPLICIT NONE

INCLUDE 'nrmmdefs.inc'

INCLUDE 'nrmmdrv.c.inc'

INCLUDE 'nrmmcntc.inc'

INCLUDE 'nrmmvehc.inc'

INCLUDE 'nrmmvppc.inc'

INCLUDE 'nrmmscnc.inc'

INCLUDE 'nrmmterc.inc'

INCLUDE 'nrmmtppc.inc'

C

INTEGER I

REAL ACOS

REAL AA, AREA1, DEFSEC, FLAG

REAL PMAX, PN, PRES1, RADSI, RRES1, RTOW

REAL SIGMA0, SIGMAF, SLIP, SOILZ, SUMZ

REAL TFOW, TRCN1, WGHT1, X2KPA, XL2

REAL XNWORT, XWID1, ZMAX

C

REAL RHARD

EXTERNAL RHARD

C

C Conversion factor for psi to KPA

PARAMETER ( X2KPA = XM2IN \* XM2IN / 1000.0 / XN2LB )

C

C Diagnostic printout of input data:

IF( KIV(3) .GT. YES )THEN

CALL DIAGIN('!0\*\*\*Routine CRLSNOW(IV3) '// 'CRREL snow model')

CALL DIAG( 'CL DIAW DSNOW DTHAW GCA' )

CALL DIAG( 'ITSURF ITUT NAMBLV NVEH NWHL' )

CALL DIAG( 'SECTW SIGMA TRAKLN TRAKWD WGHT' )

CALL DIAG( 'WT WTE' )

END IF

C

CRLSNOW = .TRUE.

C

C ... Set Snow model flag, IBASE

IF( ITSURF.EQ.3 )THEN

C

Ice

IBASE = 4

ELSE IF( ITUT.GE.11.AND.ITUT.LE.13 )THEN

```

C   Hard surface
      IBASE = 1
C   ELSE IF( DTHAW .LE. 0.0 )THEN
      ELSE IF( DFREEZ .GT. 0.0 .AND. DTHAW .LE. 0.0 )THEN
C   Frozen soil surface
      IBASE = 2
      ELSE
C   Unfrozen soil
      IBASE = 3
      END IF
C
      SIGMA0 = SIGMA
C
C ... Find maximum contact pressure
      PMAX = 0.0
      DO 10 I=1, NAMBLY
        IF( NVEH(I) .EQ. WHEEL )THEN
          AREA1 = GCA(I,JPSI)
          XNWORT = NWHL(I)
        ELSE
          AREA1 = GCA(I,JPSI) / 2.0
          XNWORT = 2.0
        END IF
C      Weight on single traction element
          WGHT1 = WGHT(I) / XNWORT
C      Maximum contact pressure of all traction elements
          PMAX = AMAX1( PMAX, WGHT1/AREA1 )
C
      10 CONTINUE
C
C ... Compute final density sigmaf
      IF( PMAX .GT. 101.5 ) THEN
        SIGMAF = 0.65
      ELSE IF( PMAX .GT. 50.8 ) THEN
        SIGMAF = 0.60
      ELSE IF( PMAX .GT. 30.5 ) THEN
        SIGMAF = 0.55
      ELSE
        SIGMAF = 0.5
      END IF
C
      FLAG = 1.0
      SUMZ = 0.0
C
C   Initial density and final density information
      ZMAX = AMAX1( 0.0, DSNOW * (1. - (SIGMA0/SIGMAF)) )

      IF(KIV(3).GT.YES)WRITE(LUN1,601)PMAX,SIGMA0,SIGMAF,ZMAX
601 FORMAT(' Max elmnt cntct pres   PMAX   =',F8.4/
&   ' Inp snow density   SIGMA0   =',F8.4/
&   ' Final snow density SIGMAF   =',F8.4/
&   ' Max avail sinkage   ZMAX    =',F8.4)
C
      DO 20 I = 1, NAMBLY

```

```

C
C   Compute terrain rolling resistance
C   (based on first assembly characteristics)
C
IF( NVEH(1) .EQ. WHEEL )THEN
  RADSI = DIAW(1)/2.0
  XWID1 = SECTW(1)
  DEFSEC = (1.0-(DFLCT(1,NJPSI)/SECTW(1)))
ELSE
  XWID1 = TRAKWD(1)
END IF
C   Weight on a single traction element
WGHT1 = WGHT(1) / XNWORT
PRES1 = WGHT1/AREA1
C
C   Account for weak soil base
C   number of passes and slip assumed constant for following eqns.
C   Number of vehicle passes made
  PN = 1.0
C   Wheel slip
  SLIP = 0.05
C
IF( NVEH(I) .EQ. WHEEL ) THEN
C
  IF (IBASE .EQ. 3) THEN
C   Unfrozen soil
    SOILZ = (10.* RADSI*pn**0.5)/((CIRCI*XWID1*RADSI*2.0)/
&      (WGHT1 * DEFSEC**(3./2.) *
&      SLIP**(1./5.))**(5.0/3.0)
C
    IF (SOILZ .LT. 0.0) SOILZ = 0.0
    ELSE
      SOILZ = 0.0
    END IF
C
    SUMZ = ZMAX + SOILZ
    XL2 = RADSI * ACOS((RADSI-SUMZ)/RADSI)
C
C   Account for tire curvature/deep snow flag
    IF( (SIGMA0.LT.0.15) .AND. (SUMZ.GE.RADSI) ) FLAG=1.5
    IF( SIGMA0 .GE. 0.15 ) THEN
      IF( SUMZ .GE. (RADSI*2.0/3.0) ) FLAG = 1.5
      IF( SUMZ .GE. RADSI ) FLAG = 2.5
    END IF
C   Belly Drag
    IF( SUMZ .GE. CL) FLAG = FLAG + 1.5
  ELSE
C
C   Tracked
C
    IF (IBASE .EQ. 3) THEN
      SOILZ = TRAKLN(1) * pn**0.5 * 0.00443 *
&      EXP((5.889 * WGHT1) / (CIRCI * XWID1 * TRAKLN(1)))
    ELSE

```

```

        SOILZ = 0.0
    END IF
C
    SUMZ = ZMAX + SOILZ

    IF(KIV(3).GT.YES)WRITE(LUN1,602)SOILZ
602 FORMAT(' Sinkage in soil      SOILZ =',F8.4)
C
C   Since NRMM does not have the approach angle of a track available
C   in the input data, is assumed to be about 26 deg. for
C   all tracked vehicles.
    AA = 26.0 * DEGRAD
    XL2 = ( SUMZ ) / SIN( AA )
C
C   Belly drag , low (flag=2.0) or high (flag=4.0) density
C
    IF( SUMZ .GE. CL ) THEN
        IF( SIGMA0 .LT. 0.15) THEN
            FLAG = 2.5
        ELSE
            FLAG = 4.0
        END IF
    END IF
END IF
C
C   Warning for deep snow
CALL ERROR( 'CRLSNO(IV3)',
& '***Warning*** Vehicle belly dragging in deep snow')
C
C..... Calculate terrain resistance for up to 4 units for wheeled vehicles
C
    IF (NVEH(I).EQ. WHEEL) THEN
        IF (I.LE.4) THEN
            RRES1 = ( ( 68.1 * ( 0.10* SIGMA0 * (XL2/XCM2IN) *
& (XWID1/XCM2IN) )**0.914 ) * FLAG ) * XN2LB
        ELSE
            RRES1 = 0.0
        END IF
    END IF
C
C   1-unit limit for tracks
C
    IF (NVEH(I).EQ. TRACK) THEN
        IF (I.LT.2) THEN
            RRES1 = ( ( 157.54 * ( 0.10* SIGMA0 * (XL2/XCM2IN) *
& (XWID1/XCM2IN) )**0.833 ) * FLAG ) * XN2LB
        ELSE
            RRES1 = 0.0
        END IF
    END IF
C
C   Terrain resistance on packed snow is zero
    IF (SIGMA0 .GE. 0.55) RRES1 = 0.0
C
C   Terrain resistance on ice is zero

```

```

      IF ((IBASE.EQ.4) .AND. ( DSNOW .LE. (1.0/XCM2IN))) RRES1 = 0.0
C
C ..... Traction calculation
C
      IF( NVEH(I) .EQ. WHEEL )THEN
      AREA1 = GCA(I,JPSI)
      XNWORT = NWHL(I)
      XWID1 = SECTW(I)
      ELSE
      AREA1 = GCA(I,JPSI) / 2.0
      XNWORT = 2.0
      XWID1 = TRAKWD(I)
      END IF
C   Weight on a single traction element
      WGHT1 = WGHT(I) / XNWORT
      PRES1 = WGHT1/AREA1
C
      IF( IBASE .NE. 4 )THEN
C       Snow on road (IBASE=1)
C       Snow on frozen or strong (RCI>100) soil (IBASE=2)
C       Snow on unfrozen soil (RCI<=100) (IBASE=3)
      IF (SIGMA0.GE.0.55) THEN
C       hard packed snow
      TRCN1 = 0.321 * (PRES1*X2KPA)**0.97
      ELSE
      TRCN1 = 0.851 * (PRES1*X2KPA)**0.823
      END IF
      ELSE
C       Snow on ice base (IBASE=4)
      IF ( DSNOW .LE. (1.0/XCM2IN)) THEN
      TRCN1 = 0.1 * (PRES1*X2KPA)
      ELSE
      IF (SIGMA0.GE.0.55) THEN
C       Disturbed snow
      TRCN1 = 0.321 * (PRES1*X2KPA)**0.97
      ELSE
C       Undisturbed snow
      TRCN1 = 0.127 * (PRES1*X2KPA)**1.06
      END IF
      END IF
      END IF
C
C   TRCN1 is a stress at this point
      TRCN1 = (TRCN1/X2KPA) * AREA1
C
      TFOW(I) = TRCN1 * XNWORT / WGHT(I)
      RTOW = RRES1 * XNWORT / WGHT(I) + RHARD(I)
C
      RTOWPB(I)= RTOW
      RTOWT(I) = RTOW
      DOWPB(I) = TFOW(I) - RTOW
C
      20 CONTINUE
C

```

```

99 RETURN
END
C RHARD Hard surface resistance for snow 19 Jun 92
C*****
C      *
C R H A R D *
C      *
C*****
      REAL FUNCTION RHARD(I)
C
C This routine computes the motion resistance for the hard surfaces
C to be added to the resistance computed for snow.
C
C 19 Jun 92 Original edit (taken from part of original NRMM snow model)
C
C Inputs:
C  I              Suspension assembly index
C  Common /PREP/
C  CPFFG(NAMBLY) F-G contact pressure factor for each element
C  Common /TPREP/
C  ITUT          Terrain type code:
C                1 = off-road (areal)terrain
C                2 = water-covered terrain
C                11 = on-road super-highway
C                12 = on-road primary road
C                13 = on-road secondary road
C                14 = on-road trail
C  Common /VEHICL/
C  NVEH(NAMBLY)  Vehicle traction assembly type: 0=tracked, 1=wheeled
C
C Outputs:
C  RHARD         Hard surface resistance coefficient
C
      IMPLICIT NONE
      INCLUDE 'nrmmdefs.inc'
      INCLUDE 'nrmmcntc.inc'
      INCLUDE 'nrmmvehc.inc'
      INCLUDE 'nrmmvppc.inc'
      INCLUDE 'nrmmtpc.inc'
C
      INTEGER I
C
      IF( NVEH(I) .EQ. WHEEL )THEN
C      Hard surface resistance coefficients (wheeled)
      IF( ITUT.EQ.1 .OR. ITUT.EQ.14 )THEN
C      Off-road and trails (no ice)
      IF( CPFFG(I).GE.4.0 )THEN
          RHARD = 0.0175
      ELSE
          RHARD = 0.015
      END IF
      ELSE IF (ITUT.EQ.11 .OR. ITUT.EQ.12 )THEN
C      Super-highways & primry roads or ice
          RHARD = 0.015

```

```

ELSE
C   Secondary roads & all others
    RHARD = 0.025
END IF
ELSE
C   Hard surface resistance coefficients (tracked)
    IF( ITUT.EQ.1 .OR. ITUT.EQ.14 )THEN
C       Off-road and trails
        RHARD = 0.0525
    ELSE IF (ITUT.EQ.11 .OR. ITUT.EQ.12 )THEN
C       Super-highways & primry roads
        RHARD = 0.0375
    ELSE
C       Secondary roads & all others
        RHARD = 0.045
    END IF
END IF
C
    IF(KIV(3).GT.YES)WRITE(LUN1,601)RHARD
    601 FORMAT(' Hard Sfc Resist. Coef. RHARD =',F8.4)
C
    RETURN
END
C THAW CRREL Thawing ground traction model 6 Jan 94
C*****
C   *
C T H A W *
C   *
C*****
    LOGICAL FUNCTION THAW()
C
C 6 May 94 Implemented in NRMM II
C
C Inputs:
C Common /DERIVE/
C DOWPB(NAMBLY) Drawbar coefficient for each assembly
C LAYER Soil layer index (Critical layer): 1=0"-6", 2=6"-12"
C RTOWPB(NAMBLY) Motion res. coef., powered or braked, each element
C RTOWT(NAMBLY) Motion res. coef., towed, each element
C Common /TERRAN/
C DTHAW Ground thawing depth [in]
C DSNOW Snow depTH [in]
C Common /VEHICL/
C NAMBLY #traction element assemblies (axles and tracks)
C
C Outputs:
C THAW Return status .TRUE. = O-K
C Common /DERIVE/
C DOWPB(NAMBLY) Drawbar coefficient for each assembly
C MRMUL(NAMBLY) Winter model soil resistance multiplier, each element
C RTOWPB(NAMBLY) Motion res. coef., powered or braked, each element
C RTOWT(NAMBLY) Motion res. coef., towed, each element
C TFMUL(NAMBLY) Winter model traction multiplier, each element
C TFOW(NAMBLY) Traction coefficient from soil, each element

```

```

C
C External:
C  MRMULT  Soil motion coefficient multiplier for thawing soils
C  TRMULT  Soil traction coefficient multiplier for thawing soils
C
C Internal:
C  I      Suspension assembly index
C  STATOK  Temporary status flag
C
C  IMPLICIT NONE
C  INCLUDE 'nrmmdefs.inc'
C  INCLUDE 'nrmmdrv.c.inc'
C  INCLUDE 'nrmmcntc.inc'
C  INCLUDE 'nrmmvehc.inc'
C  INCLUDE 'nrmmvppc.inc'
C  INCLUDE 'nrmmterc.inc'
C  INCLUDE 'nrmmtppc.inc'
C
C  LOGICAL STATOK
C  INTEGER I
C  REAL  MRMULT, TRMULT
C  EXTERNAL MRMULT, TRMULT
C
C  Diagnostic printout of input data:
C  IF( KIV(3) .GT. YES )THEN
C    CALL DIAGIN('!0***Routine THAW(IV3) '//
C  & 'CRREL Thawing soil traction model')
C    CALL DIAG( 'DOWPB DTHAW DSNOW LAYER NAMBLY' )
C    CALL DIAG( 'RTOWPB RTOWT' )
C  END IF
C
C  STATOK=.TRUE.
C  DO 10 I=1, NAMBLY
C    TFMUL(I) = TRMULT()
C    IF(STATOK)STATOK = TFMUL(I).GT.0
C    TFOW(I) = (DOWPB(I)+RTOWPB(I))*TFMUL(I)
C    MRMUL(I) = MRMULT(I)
C    IF(STATOK)STATOK = MRMUL(I).LT.999.
C    RTOWPB(I) = RTOWPB(I)*MRMUL(I)
C    RTOWT(I) = RTOWT(I)*MRMUL(I)
C    DOWPB(I) = TFOW(I) - RTOWPB(I)
C  10 CONTINUE
C    THAW = STATOK
C
C
C  Check for validity
C  IF( LAYER .EQ. 2 )
C    & CALL ERROR( 'THAW','Critical depth > 6" )
C  IF( DSNOW .GT. 1./XCM2IN)
C    & CALL ERROR( 'THAW','Snow cover > 1 cm.' )
C
C  RETURN
C  END
C  TRMULT Traction multiplier for thawing soils 6 Jan 94
C*****

```

```

C      *
C TRMULT*
C      *
C*****
C      REAL FUNCTION TRMULT()
C
C      May 92  Model based on US ARMY CRREL research done by Sally Shoop
C              Coded by Jim Slota, OptiMetrics for CRREL. (SSM 6.2)
C      23 Jun 92  Implemented in CAMMS by R. B. Ahlvin, WES
C      6 Jan 94  Implemented in NRMM II by R.B.Ahlvin
C
C      This function returns a multiplier value to modify drawbar-pull
C      in lbs. Traction is reduced for travel over a thawing soil layer
C      that overlays a frozen soil layer. Calculations are applicable
C      only for sandy soils with little or no snow cover, and for
C      vehicles with a critical depth of less than 6 inches. The wetness
C      index, as calculated by the SMSP model, is also required.
C
C Inputs:
C Common /TERRAN/
C DTHAW      Depth of thawing is soil [in]
C KUSCS      USCS soil type code: 1=SW, 2=SP, 3=SM, 4=SC, 5=SMSC,
C            6=CL, 7=ML, 8=CLML, 9=CH, 10=MH, 11=OL, 12=OH, 13=WATER,
C            14=PAVEMENT, 15=ROCK, 16=GW, 17=GP, 18=GM, 19=GC, 20=Pt
C KWI        SMSP wetness index: 0=arid, 1=dry, 2=average, 3=wet,
C            4=saturated, 5=waterlogged
C Output:
C TRMULT    Tractio multiplier
C
C IMPLICIT NONE
C INCLUDE 'nrmmdefs.inc'
C INCLUDE 'nrmmntc.inc'
C INCLUDE 'nrmmterc.inc'
C INCLUDE 'nrmmvehc.inc'
C
C INTEGER I,J, LENSTR
C REAL MRMULT, THAWCM
C LOGICAL SVALID(20)
C CHARACTER *4 ZUSCS(20)
C CHARACTER *5 ZVTYPE
C EXTERNAL LENSTR
C DATA ZUSCS/'SW','SP','SM ','SC ','SMSC',
C &      'CL','ML','CLML','CH ','MH ',
C &      'OL','OH','WATR','PVMT','ROCK',
C &      'GW','GP','GM ','GC ','Pt '/
C
C DATA (SVALID(J),J= 1, 5)
C & /.TRUE.,.TRUE.,.TRUE.,.TRUE.,.TRUE./
C SW SP SM SC SMSC
C DATA (SVALID(J),J= 6,10)
C & /.TRUE.,.FALSE.,.FALSE.,.FALSE.,.FALSE./
C CL ML CLML CH MH
C DATA (SVALID(J),J=11,15)
C & /.FALSE.,.FALSE.,.FALSE.,.FALSE.,.FALSE./

```

```

C   OL  OH  WATR  PVMT  ROCK
      DATA (SVALID(J),J)=16,20)
      & /.TRUE. ,.TRUE. ,.TRUE. ,.TRUE. ,.TRUE./
C   GW  GP  GM  GC  Pt
C
      THAWCM = DTHAW / XCM2IN
      IF( (THAWCM .GT. 2.5) .AND. (THAWCM .LT. 15.0)) THEN
          TRMULT = 2.379 * (1.0/(THAWCM*THAWCM)) + 0.619
      ELSE IF (THAWCM .GE. 15.0) THEN
          TRMULT = 0.63
      ELSE
          TRMULT = 1.0
      END IF
      IF( .NOT.SVALID(KUSCS) ) THEN
          WRITE(ERRMSG,9901)KUSCS,ZUSCS(KUSCS)(1:LENSTR(ZUSCS(KUSCS)))
9901  FORMAT('Relations not implemented for ',
      &      'soil type KUSCS=',I2,' (' ,A,')':
      &      'NVEH(I)=' ,I1,' (' ,A,')')
          CALL ERROR( 'TRMULT', ERRMSG )
      END IF
C
      RETURN
C
C MRMULT Motion resistance multiplier for thawing soils 23 Jun 92
C *****
C      *
C M R M U L T *
C      *
C *****
      ENTRY MRMULT(I)
C
C   May 92   Model based on US ARMY CRREL research done by Sally Shoop
C           Coded by Jim Slota, OptiMetrics for CRREL. (SSM 6.2)
C   6 May 94   Implemented in NRMM II by R.B.Ahlvin
C
C   This function returns a multiplier value to motion resistance
C   values. This applies to travel over a thawing soil layer
C   overlaying a frozen layer. Calculations are applicable only for
C   wheeled vehicles on sandy soils with little or no sno cover,
C   and for vehicles with a critical depth of less than 6 inches. The
C   wetness index, as calculated by the SMSP model, is also required.
C
C Inputs:
C   I           Suspension assembly index
C   Common /TERRAN/
C   DTHAW       Depth of thawing is soil [in]
C   KUSCS       USCS soil type code: 1=SW, 2=SP, 3=SM, 4=SC, 5=SMSC,
C               6=CL, 7=ML, 8=CLML, 9=CH, 10=MH, 11=OL, 12=OH, 13=WATER,
C               14=PAVEMENT, 15=ROCK, 16=GW, 17=GP, 18=GM, 19=GC, 20=Pt
C   KWI         SMSP wetness index: 0=arid, 1=dry, 2=average, 3=wet,
C               4=saturated, 5=waterlogged
C   Common /VEHICL/
C   NVEH(NAMBLY) Vehicle traction assembly type: 0=tracked, 1=wheeled
C

```

```

C Output:
C   MRMULT      Motion resistance multiplier
C
C       MRMULT = 1.0
C
C       THAWCM = DTHAW / XCM2IN
C   The following 3 lines handle cases for which THAWCM < 2.5 cm
      IF( THAWCM .LE. 2.5 )THEN
          MRMULT = 1.0
      ELSE IF( (THAWCM .GT. 2.5) .AND. (THAWCM .LT. 4.0)) THEN
          MRMULT = 2.883 * THAWCM - 6.056
      ELSE IF( (THAWCM .GE. 4.0) .AND. (THAWCM .LT. 8.0)) THEN
          MRMULT = -0.22*THAWCM*THAWCM + 3.54*THAWCM - 5.24
      ELSE IF( (THAWCM .GE. 8.) .AND. (THAWCM .LT. 12.0)) THEN
          MRMULT = 0.225*THAWCM + 7.2167
      ELSE
          MRMULT = 10.0
      END IF
      IF( NVEH(I).EQ. TRACK )
&   CALL ERROR( 'MRMULT',
&   'Multiplier may not be valid for TRACKED elements' )
      IF( .NOT.SVALID(KUSCS) ) THEN
          WRITE(ERRMSG,9901)KUSCS,ZUSCS(KUSCS)(1:LENSTR(ZUSCS(KUSCS))),
&   NVEH(I),ZVTYPE
&   CALL ERROR( 'MRMULT', ERRMSG )
      END IF
C
C   RETURN
C   END

```

## APPENDIX C. TRACTION COEFFICIENTS ON PACKED SNOW

Traction on groomed, shallow snow was measured with three different vehicles—the CRREL Instrumented Vehicle (CIV), the Saab Friction Tester and the Uniroyal-Goodrich Traction Tester (U-G)—in Shoop (1993a). Several methods of reporting the traction coefficient ( $\mu$ ) were used:

- The maximum value ( $\mu_{\max}$ );
- An average peak value ( $\mu_{\text{peak}}$ );
- The value at 12% slip ( $\mu_{12\% \text{slip}}$ ); and
- The SAE-specified  $\mu$  ( $\mu_{\text{SAE}}$ ).

These measurements are compared to other published traction coefficients on groomed snow in Figure C1. The predicted traction values, using CRREL's Cold Regions Mobility Models, is expressed in coefficient form and is shown by the open circles at the bottom of the figure.

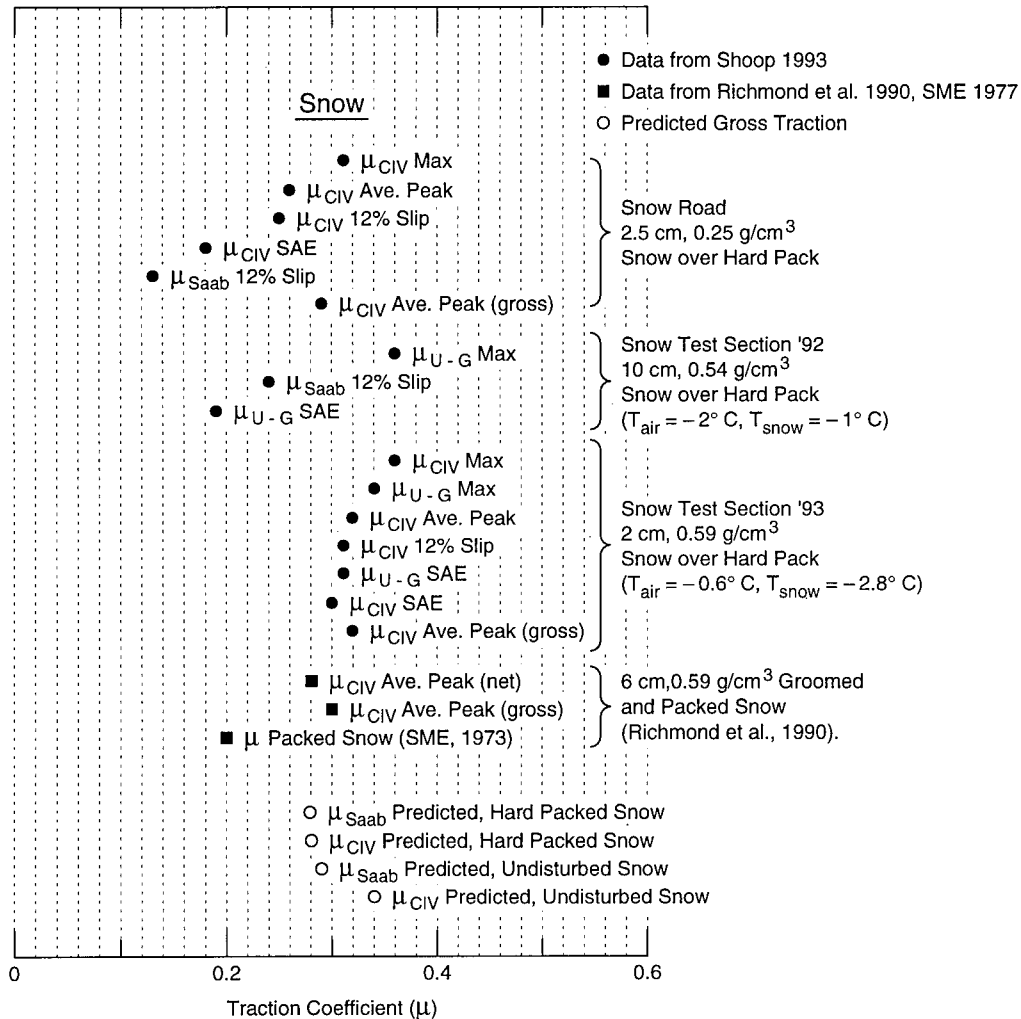

Figure C1. Comparison of measured, published and predicted values of traction on shallow groomed snow.

## APPENDIX D: NRMM CHECKOUT DATA

### TERRAIN UNIT INPUT

```

38 8 Checkout terrain for CRREL winter effects model 6 May 94
!
! 1) Best possible on-road terrain
! NTU TUID AREA IROAD ISCOND GRADE ACTRMS RDA EANG RADC
! 1 'BstON' 1.00 1 1 0 0.0999 0 5000
!
! 2) Best possible off-road terrain
! NTU TUID AREA IROAD ISCOND GRADE ACTRMS RDA USCS KWI RCI1 RCI2 DBROCK
! 2 'BstCC' 1.00 0 1 0 0.0999 SM 1 300 300 99
!
! 3) Soft soil effects, Soil strength = 100
! NTU TUID AREA IROAD ISCOND GRADE ACTRMS RDA USCS KWI RCI1 RCI2 DBROCK
! 3 'CI100' 1.00 0 1 0 0.0999 SM 2 100 100 99
!
! 4) Soft soil effects, Soil strength = 50
! NTU TUID AREA IROAD ISCOND GRADE ACTRMS RDA USCS KWI RCI1 RCI2 DBROCK
! 4 'CI50' 1.00 0 1 0 0.0999 SM 3 50 50 99
!
! 5) Soft soil effects, Soil strength = 20
! NTU TUID AREA IROAD ISCOND GRADE ACTRMS RDA USCS KWI RCI1 RCI2 DBROCK
! 5 'CI20' 1.00 0 1 0 0.0999 SM 4 20 20 99
!
! 6) Frozen ground, w/Ice base
! NTU TUID AREA IROAD ISCOND GRADE ACTRMS RDA USCS KWI RCI1 RCI2 DBROCK
! 6 'Ice' 1.00 0 1 0 0.0999 SM 1 300 300 99
! DSNOW SIGMA DFREEZ DTHAW TMOIST ICE
WIN 0.0 0.2 99.9 0.0 0.0 1
!
! 7) 1-in snow on frozen ground, w/Ice base
! NTU TUID AREA IROAD ISCOND GRADE ACTRMS RDA USCS KWI RCI1 RCI2 DBROCK
! 7 '1in/I' 1.00 0 1 0 0.0999 SM 1 300 300 99
! DSNOW SIGMA DFREEZ DTHAW TMOIST ICE
WIN 1.0 0.2 99.9 0.0 0.0 1
!
! 8) 10-in snow on frozen ground, w/Ice base
! NTU TUID AREA IROAD ISCOND GRADE ACTRMS RDA USCS KWI RCI1 RCI2 DBROCK
! 8 '10inI' 1.00 0 1 0 0.0999 SM 1 300 300 99
! DSNOW SIGMA DFREEZ DTHAW TMOIST ICE
WIN 10.0 0.2 99.9 0.0 0.0 1
!
! 9) 1-in snow on frozen ground
! NTU TUID AREA IROAD ISCOND GRADE ACTRMS RDA USCS KWI RCI1 RCI2 DBROCK
! 9 '1in' 1.00 0 1 0 0.0999 SM 1 300 300 99
! DSNOW SIGMA DFREEZ DTHAW TMOIST ICE
WIN 1.0 0.2 99.9 0.0 0.0 0
!
! 10) 10-in snow on frozen ground
! NTU TUID AREA IROAD ISCOND GRADE ACTRMS RDA USCS KWI RCI1 RCI2 DBROCK
! 10 '10in' 1.00 0 1 0 0.0999 SM 1 300 300 99
! DSNOW SIGMA DFREEZ DTHAW TMOIST ICE
WIN 10.0 0.2 99.9 0.0 0.0 0
!
! 11) 20-in snow on frozen ground
! NTU TUID AREA IROAD ISCOND GRADE ACTRMS RDA USCS KWI RCI1 RCI2 DBROCK
! 11 '20in' 1.00 0 1 0 0.0999 SM 1 300 300 99
! DSNOW SIGMA DFREEZ DTHAW TMOIST ICE
WIN 20.0 0.2 99.9 0.0 0.0 0
!
! 12) 10-in snow on frozen ground, density= 0.1
! NTU TUID AREA IROAD ISCOND GRADE ACTRMS RDA USCS KWI RCI1 RCI2 DBROCK
! 12 '10".1' 1.00 0 1 0 0.0999 SM 1 300 300 99
! DSNOW SIGMA DFREEZ DTHAW TMOIST ICE
WIN 10.0 0.1 99.9 0.0 0.0 0
!

```

! 13) 10-in snow on frozen ground, density= 0.3  
! NTU TUID AREA IROAD ISCOND GRADE ACTRMS RDA USCS KWI RCI1 RCI2 DBROCK  
13 '10".3' 1.00 0 1 0 0.0 999 SM 1 300 300 99  
! DSNOW SIGMA DFREEZ DTHAW TMOIST ICE  
WIN 10.0 0.3 99.9 0.0 0.0 0

! 14) 10-in snow on frozen ground, density= 0.4  
! NTU TUID AREA IROAD ISCOND GRADE ACTRMS RDA USCS KWI RCI1 RCI2 DBROCK  
14 '10".4' 1.00 0 1 0 0.0 999 SM 1 300 300 99  
! DSNOW SIGMA DFREEZ DTHAW TMOIST ICE  
WIN 10.0 0.4 99.9 0.0 0.0 0

! 15) 10-in snow on road  
! NTU TUID AREA IROAD ISCOND GRADE ACTRMS RDA EANG RADC  
15 '10"ON' 1.00 1 5 0 0.0 999 0 5000  
! DSNOW SIGMA DFREEZ DTHAW TMOIST ICE  
WIN 10.0 0.2 0.0 0.0 0.0 0

! 16) 10-in snow on unfrozen ground, CI=150  
! NTU TUID AREA IROAD ISCOND GRADE ACTRMS RDA USCS KWI RCI1 RCI2 DBROCK  
16 '10CI150' 1.00 0 1 0 0.0 999 SM 1 150 150 99  
! DSNOW SIGMA DFREEZ DTHAW TMOIST ICE  
WIN 10.0 0.2 0.0 0.0 0.0 0

! 17) 10-in snow on unfrozen ground, CI=50  
! NTU TUID AREA IROAD ISCOND GRADE ACTRMS RDA USCS KWI RCI1 RCI2 DBROCK  
17 '10CI50' 1.00 0 1 0 0.0 999 SM 2 50 50 99  
! DSNOW SIGMA DFREEZ DTHAW TMOIST ICE  
WIN 10.0 0.2 0.0 0.0 0.0 0

! 18) 10-in snow on unfrozen ground, CI=20  
! NTU TUID AREA IROAD ISCOND GRADE ACTRMS RDA USCS KWI RCI1 RCI2 DBROCK  
18 '10CI20' 1.00 0 1 0 0.0 999 SM 3 20 20 99  
! DSNOW SIGMA DFREEZ DTHAW TMOIST ICE  
WIN 10.0 0.2 0.0 0.0 0.0 0

! 19) 10-in snow on 2-in frozen ground  
! NTU TUID AREA IROAD ISCOND GRADE ACTRMS RDA USCS KWI RCI1 RCI2 DBROCK  
19 '2frez' 1.00 0 1 0 0.0 999 SM 1 300 300 99  
! DSNOW SIGMA DFREEZ DTHAW TMOIST ICE  
WIN 10.0 0.2 2.0 0.0 0.0 0

! 20) 10-in snow on 4-in frozen ground  
! NTU TUID AREA IROAD ISCOND GRADE ACTRMS RDA USCS KWI RCI1 RCI2 DBROCK  
20 '4frez' 1.00 0 1 0 0.0 999 SM 1 300 300 99  
! DSNOW SIGMA DFREEZ DTHAW TMOIST ICE  
WIN 10.0 0.2 4.0 0.0 0.0 0

! 21) 10-in snow on 6-in frozen ground  
! NTU TUID AREA IROAD ISCOND GRADE ACTRMS RDA USCS KWI RCI1 RCI2 DBROCK  
21 '6frez' 1.00 0 1 0 0.0 999 SM 1 300 300 99  
! DSNOW SIGMA DFREEZ DTHAW TMOIST ICE  
WIN 10.0 0.2 6.0 0.0 0.0 0

! 22) 10-in snow on 12-in frozen ground  
! NTU TUID AREA IROAD ISCOND GRADE ACTRMS RDA USCS KWI RCI1 RCI2 DBROCK  
22 '12frez' 1.00 0 1 0 0.0 999 SM 1 300 300 99  
! DSNOW SIGMA DFREEZ DTHAW TMOIST ICE  
WIN 10.0 0.2 12.0 0.0 0.0 0

! 23) 10-in snow on 2-in thawing ground (using WI)  
! NTU TUID AREA IROAD ISCOND GRADE ACTRMS RDA USCS KWI RCI1 RCI2 DBROCK  
23 '2thaw' 1.00 0 1 0 0.0 999 SM 3 50 50 99  
! DSNOW SIGMA DFREEZ DTHAW TMOIST ICE  
WIN 10.0 0.2 12.0 2.0 0.0 0

! 24) 10-in snow on 4-in thawing ground (using WI)  
! NTU TUID AREA IROAD ISCOND GRADE ACTRMS RDA USCS KWI RCI1 RCI2 DBROCK  
24 '4thaw' 1.00 0 1 0 0.0999 SM 4 20 20 99  
! DSNOW SIGMA DFREEZ DTHAW TMOIST ICE  
WIN 10.0 0.2 12.0 4.0 0.0 0  
!  
! 25) 10-in snow on 8-in thawing ground (using WI)  
! NTU TUID AREA IROAD ISCOND GRADE ACTRMS RDA USCS KWI RCI1 RCI2 DBROCK  
25 '8thaw' 1.00 0 1 0 0.0999 SM 3 50 50 99  
! DSNOW SIGMA DFREEZ DTHAW TMOIST ICE  
WIN 10.0 0.2 12.0 8.0 0.0 0  
!! 26) 10-in snow on 8-in thawing ground, 10% moisture content  
! NTU TUID AREA IROAD ISCOND GRADE ACTRMS RDA USCS KWI RCI1 RCI2 DBROCK  
26 '8thM10' 1.00 0 1 0 0.0999 SM 3 50 50 99  
! DSNOW SIGMA DFREEZ DTHAW TMOIST ICE  
WIN 10.0 0.2 12.0 8.0 10.0 0  
!  
! 27) 10-in snow on 8-in thawing ground, 30% moisture content  
! NTU TUID AREA IROAD ISCOND GRADE ACTRMS RDA USCS KWI RCI1 RCI2 DBROCK  
27 '8thM30' 1.00 0 1 0 0.0999 SM 3 50 50 99  
! DSNOW SIGMA DFREEZ DTHAW TMOIST ICE  
WIN 10.0 0.2 12.0 8.0 30.0 0  
!  
! 28) 10-in snow on 8-in thawing ground, 50% moisture content  
! NTU TUID AREA IROAD ISCOND GRADE ACTRMS RDA USCS KWI RCI1 RCI2 DBROCK  
28 '8thM30' 1.00 0 1 0 0.0999 SM 4 50 50 99  
! DSNOW SIGMA DFREEZ DTHAW TMOIST ICE  
WIN 10.0 0.2 12.0 8.0 50.0 0  
!  
! 29) 0-in snow on 2-in frozen ground  
! NTU TUID AREA IROAD ISCOND GRADE ACTRMS RDA USCS KWI RCI1 RCI2 DBROCK  
29 '2frez' 1.00 0 1 0 0.0999 SM 1 300 300 99  
! DSNOW SIGMA DFREEZ DTHAW TMOIST ICE  
WIN 0.0 0.2 2.0 0.0 0.0 0  
!  
! 30) 0-in snow on 4-in frozen ground  
! NTU TUID AREA IROAD ISCOND GRADE ACTRMS RDA USCS KWI RCI1 RCI2 DBROCK  
30 '4frez' 1.00 0 1 0 0.0999 SM 1 300 300 99  
! DSNOW SIGMA DFREEZ DTHAW TMOIST ICE  
WIN 0.0 0.2 4.0 0.0 0.0 0  
!  
! 31) 0-in snow on 6-in frozen ground  
! NTU TUID AREA IROAD ISCOND GRADE ACTRMS RDA USCS KWI RCI1 RCI2 DBROCK  
31 '6frez' 1.00 0 1 0 0.0999 SM 1 300 300 99  
! DSNOW SIGMA DFREEZ DTHAW TMOIST ICE  
WIN 0.0 0.2 6.0 0.0 0.0 0  
!  
! 32) 0-in snow on 12-in frozen ground  
! NTU TUID AREA IROAD ISCOND GRADE ACTRMS RDA USCS KWI RCI1 RCI2 DBROCK  
32 '12frez' 1.00 0 1 0 0.0999 SM 1 300 300 99  
! DSNOW SIGMA DFREEZ DTHAW TMOIST ICE  
WIN 0.0 0.2 12.0 0.0 0.0 0  
!  
! 33) 0-in snow on 2-in thawing ground (using WI)  
! NTU TUID AREA IROAD ISCOND GRADE ACTRMS RDA USCS KWI RCI1 RCI2 DBROCK  
33 '2thaw' 1.00 0 1 0 0.0999 SM 3 50 50 99  
! DSNOW SIGMA DFREEZ DTHAW TMOIST ICE  
WIN 0.0 0.2 12.0 2.0 0.0 0  
!  
! 34) 0-in snow on 4-in thawing ground (using WI)  
! NTU TUID AREA IROAD ISCOND GRADE ACTRMS RDA USCS KWI RCI1 RCI2 DBROCK  
34 '4thaw' 1.00 0 1 0 0.0999 SM 4 20 20 99  
! DSNOW SIGMA DFREEZ DTHAW TMOIST ICE  
WIN 0.0 0.2 12.0 4.0 0.0 0  
!

! 35) 0-in snow on 8-in thawing ground (using WI)  
! NTU TUID AREA IROAD ISCOND GRADE ACTRMS RDA USCS KWI RCI1 RCI2 DBROCK  
35 '8thaw' 1.00 0 1 0 0.0999 SM 3 50 50 99  
! DSNOW SIGMA DFREEZ DTHAW TMOIST ICE  
WIN 0.0 0.2 12.0 8.0 0.0 0  
!  
! 36) 0-in snow on 8-in thawing ground, 5% moisture content  
! NTU TUID AREA IROAD ISCOND GRADE ACTRMS RDA USCS KWI RCI1 RCI2 DBROCK  
36 '8thM10' 1.00 0 1 0 0.0999 SM 3 50 50 99  
! DSNOW SIGMA DFREEZ DTHAW TMOIST ICE  
WIN 0.0 0.2 12.0 8.0 5.0 0  
!  
! 37) 0-in snow on 8-in thawing ground, 10% moisture content  
! NTU TUID AREA IROAD ISCOND GRADE ACTRMS RDA USCS KWI RCI1 RCI2 DBROCK  
37 '8thM30' 1.00 0 1 0 0.0999 SM 3 50 50 99  
! DSNOW SIGMA DFREEZ DTHAW TMOIST ICE  
WIN 0.0 0.2 12.0 8.0 10.0 0  
!  
! 38) 0-in snow on 8-in thawing ground, 30% moisture content  
! NTU TUID AREA IROAD ISCOND GRADE ACTRMS RDA USCS KWI RCI1 RCI2 DBROCK  
38 '8thM30' 1.00 0 1 0 0.0999 SM 4 50 50 99  
! DSNOW SIGMA DFREEZ DTHAW TMOIST ICE  
WIN 0.0 0.2 12.0 8.0 30.0 0  
54 8 Checkout terrain for CRREL winter effects model 6 May 94  
!  
! 39) ZTEST #1:2" frozen ground,RCI1,2=5,5;KWI=1  
! NTU TUID AREA IROAD ISCOND GRADE ACTRMS RDA USCS KWI RCI1 RCI2 DBROCK  
39 'zt-1' 1.00 0 1 0 0.0999 SM 1 5 5 99  
! DSNOW SIGMA DFREEZ DTHAW TMOIST ICE  
WIN 0.0 0.2 2.0 0.0 0.0 0  
!  
! 40) ZTEST #2:2" frozen ground,RCI1,2=20,20;KWI=1  
! NTU TUID AREA IROAD ISCOND GRADE ACTRMS RDA USCS KWI RCI1 RCI2 DBROCK  
40 'zt-2' 1.00 0 1 0 0.0999 SM 1 20 20 99  
! DSNOW SIGMA DFREEZ DTHAW TMOIST ICE  
WIN 0.0 0.2 2.0 0.0 0.0 0  
!  
! 41) ZTEST #3:2" frozen ground,RCI1,2=100,100;KWI=1  
! NTU TUID AREA IROAD ISCOND GRADE ACTRMS RDA USCS KWI RCI1 RCI2 DBROCK  
41 'zt-3' 1.00 0 1 0 0.0999 SM 1 100 100 99  
! DSNOW SIGMA DFREEZ DTHAW TMOIST ICE  
WIN 0.0 0.2 2.0 0.0 0.0 0  
!  
! 42) ZTEST #4:2" frozen ground,RCI1,2=5,5; KWI=5  
! NTU TUID AREA IROAD ISCOND GRADE ACTRMS RDA USCS KWI RCI1 RCI2 DBROCK  
42 'zt-4' 1.00 0 1 0 0.0999 SM 5 5 5 99  
! DSNOW SIGMA DFREEZ DTHAW TMOIST ICE  
WIN 0.0 0.2 2.0 0.0 0.0 0  
!  
! 43) ZTEST #5:2" frozen ground,RCI1,2=20,20;KWI=5  
! NTU TUID AREA IROAD ISCOND GRADE ACTRMS RDA USCS KWI RCI1 RCI2 DBROCK  
43 'zt-5' 1.00 0 1 0 0.0999 SM 5 20 20 99  
! DSNOW SIGMA DFREEZ DTHAW TMOIST ICE  
WIN 0.0 0.2 2.0 0.0 0.0 0  
!  
! 44) ZTEST #6:2" frozen ground,RCI1,2=100,100;KWI=5  
! NTU TUID AREA IROAD ISCOND GRADE ACTRMS RDA USCS KWI RCI1 RCI2 DBROCK  
44 'zt-6' 1.00 0 1 0 0.0999 SM 5 100 100 99  
! DSNOW SIGMA DFREEZ DTHAW TMOIST ICE  
WIN 0.0 0.2 2.0 0.0 0.0 0  
!  
! 45) 0-in snow on 2-in thawing ground (using WI), wet conditions  
! NTU TUID AREA IROAD ISCOND GRADE ACTRMS RDA USCS KWI RCI1 RCI2 DBROCK  
45 '2thaw' 1.00 0 1 0 0.0999 SM 5 50 50 99  
! DSNOW SIGMA DFREEZ DTHAW TMOIST ICE  
WIN 0.0 0.2 12.0 2.0 0.0 0  
!

! 46) SOIL TEST#1: KWI=5, RCI1,2=150, DFREEZE=12in;DTHAW=2in; SW  
! NTU TUID AREA IROAD ISCOND GRADE ACTRMS RDA USCS KWI RCI1 RCI2 DBROCK  
46 'st-1' 1.00 0 1 0 0.0999 SW 5 150 150 99  
! DSNOW SIGMA DFREEZ DTHAW TMOIST ICE  
WIN 0.0 0.2 12.0 2.0 0.0 0  
!  
! 47) SOIL TEST#2: KWI=5, RCI1,2=150, DFREEZE=12in;DTHAW=2in; SP  
! NTU TUID AREA IROAD ISCOND GRADE ACTRMS RDA USCS KWI RCI1 RCI2 DBROCK  
47 'st-2' 1.00 0 1 0 0.0999 SP 5 150 150 99  
! DSNOW SIGMA DFREEZ DTHAW TMOIST ICE  
WIN 0.0 0.2 12.0 2.0 0.0 0  
!  
! 48) SOIL TEST#3: KWI=5, RCI1,2=150, DFREEZE=12in;DTHAW=2in; SM  
! NTU TUID AREA IROAD ISCOND GRADE ACTRMS RDA USCS KWI RCI1 RCI2 DBROCK  
48 'st-3' 1.00 0 1 0 0.0999 SW 5 150 150 99  
! DSNOW SIGMA DFREEZ DTHAW TMOIST ICE  
WIN 0.0 0.2 12.0 2.0 0.0 0  
!  
! 49) SOIL TEST#4: KWI=5, RCI1,2=150, DFREEZE=12in;DTHAW=2in; SC  
! NTU TUID AREA IROAD ISCOND GRADE ACTRMS RDA USCS KWI RCI1 RCI2 DBROCK  
49 'st-4' 1.00 0 1 0 0.0999 SC 5 150 150 99  
! DSNOW SIGMA DFREEZ DTHAW TMOIST ICE  
WIN 0.0 0.2 12.0 2.0 0.0 0  
!  
! 50) SOIL TEST#5: KWI=5, RCI1,2=150, DFREEZE=12in;DTHAW=2in; SMSC  
! NTU TUID AREA IROAD ISCOND GRADE ACTRMS RDA USCS KWI RCI1 RCI2 DBROCK  
50 'st-5' 1.00 0 1 0 0.0999 SMSC 5 150 150 99  
! DSNOW SIGMA DFREEZ DTHAW TMOIST ICE  
WIN 0.0 0.2 12.0 2.0 0.0 0  
!  
! 51) SOIL TEST#6: KWI=5, RCI1,2=150, DFREEZE=12in;DTHAW=2in; CL  
! NTU TUID AREA IROAD ISCOND GRADE ACTRMS RDA USCS KWI RCI1 RCI2 DBROCK  
51 'st-6' 1.00 0 1 0 0.0999 CL 5 150 150 99  
! DSNOW SIGMA DFREEZ DTHAW TMOIST ICE  
WIN 0.0 0.2 12.0 2.0 0.0 0  
!  
! 52) SOIL TEST#7: KWI=5, RCI1,2=150, DFREEZE=12in;DTHAW=2in; ML  
! NTU TUID AREA IROAD ISCOND GRADE ACTRMS RDA USCS KWI RCI1 RCI2 DBROCK  
52 'st-7' 1.00 0 1 0 0.0999 ML 5 150 150 99  
! DSNOW SIGMA DFREEZ DTHAW TMOIST ICE  
WIN 0.0 0.2 12.0 2.0 0.0 0  
!  
! 53) SOIL TEST#8: KWI=5, RCI1,2=150, DFREEZE=12in;DTHAW=2in; CLML  
! NTU TUID AREA IROAD ISCOND GRADE ACTRMS RDA USCS KWI RCI1 RCI2 DBROCK  
53 'st-8' 1.00 0 1 0 0.0999 CLML 5 150 150 99  
! DSNOW SIGMA DFREEZ DTHAW TMOIST ICE  
WIN 0.0 0.2 12.0 2.0 0.0 0  
!  
! 54) SOIL TEST#9: KWI=5, RCI1,2=150, DFREEZE=12in;DTHAW=2in; CH  
! NTU TUID AREA IROAD ISCOND GRADE ACTRMS RDA USCS KWI RCI1 RCI2 DBROCK  
54 'st-9' 1.00 0 1 0 0.0999 CH 5 150 150 99  
! DSNOW SIGMA DFREEZ DTHAW TMOIST ICE  
WIN 0.0 0.2 12.0 2.0 0.0 0  
!  
! 55) SOIL TEST#10: KWI=5, RCI1,2=150, DFREEZE=12in;DTHAW=2in; MH  
! NTU TUID AREA IROAD ISCOND GRADE ACTRMS RDA USCS KWI RCI1 RCI2 DBROCK  
55 'st-10' 1.00 0 1 0 0.0999 MH 5 150 150 99  
! DSNOW SIGMA DFREEZ DTHAW TMOIST ICE  
WIN 0.0 0.2 12.0 2.0 0.0 0  
!  
! 56) SOIL TEST#11: KWI=5, RCI1,2=150, DFREEZE=12in;DTHAW=2in; OL  
! NTU TUID AREA IROAD ISCOND GRADE ACTRMS RDA USCS KWI RCI1 RCI2 DBROCK  
56 'st-3' 1.00 0 1 0 0.0999 OL 5 150 150 99  
! DSNOW SIGMA DFREEZ DTHAW TMOIST ICE  
WIN 0.0 0.2 12.0 2.0 0.0 0  
!

! 57) SOIL TEST#12: KWI=5, RCI1,2=150, DFREEZE=12in;DTHAW=2in; OH  
! NTU TUID AREA IROAD ISCOND GRADE ACTRMS RDA USCS KWI RCI1 RCI2 DBROCK  
57 'st-12' 1.00 0 1 0 0.0 999 OH 5 150 150 99  
! DSNOW SIGMA DFREEZ DTHAW TMOIST ICE  
WIN 0.0 0.2 12.0 2.0 0.0 0  
!  
! 58) SOIL TEST#13: KWI=5, RCI1,2=150, DFREEZE=12in;DTHAW=2in; WATR  
! NTU TUID AREA IROAD ISCOND GRADE ACTRMS RDA USCS KWI RCI1 RCI2 DBROCK  
58 'st-13' 1.00 0 1 0 0.0 999 WATR 5 150 150 99  
! DSNOW SIGMA DFREEZ DTHAW TMOIST ICE  
WIN 0.0 0.2 12.0 2.0 0.0 0  
!  
! 59) SOIL TEST#14: KWI=5, RCI1,2=150, DFREEZE=12in;DTHAW=2in; PAVE  
! NTU TUID AREA IROAD ISCOND GRADE ACTRMS RDA USCS KWI RCI1 RCI2 DBROCK  
59 'st-14' 1.00 0 1 0 0.0 999 PAVE 5 150 150 99  
! DSNOW SIGMA DFREEZ DTHAW TMOIST ICE  
WIN 0.0 0.2 12.0 2.0 0.0 0  
!  
! 60) SOIL TEST#15: KWI=5, RCI1,2=150, DFREEZE=12in;DTHAW=2in; ROCK  
! NTU TUID AREA IROAD ISCOND GRADE ACTRMS RDA USCS KWI RCI1 RCI2 DBROCK  
60 'st-15' 1.00 0 1 0 0.0 999 ROCK 5 150 150 99  
! DSNOW SIGMA DFREEZ DTHAW TMOIST ICE  
WIN 0.0 0.2 12.0 2.0 0.0 0  
!! 61) SOIL TEST#16: KWI=5, RCI1,2=150, DFREEZE=12in;DTHAW=2in; GW  
! NTU TUID AREA IROAD ISCOND GRADE ACTRMS RDA USCS KWI RCI1 RCI2 DBROCK  
61 'st-16' 1.00 0 1 0 0.0 999 GW 5 150 150 99  
! DSNOW SIGMA DFREEZ DTHAW TMOIST ICE  
WIN 0.0 0.2 12.0 2.0 0.0 0  
!  
! 62) SOIL TEST#17: KWI=5, RCI1,2=150, DFREEZE=12in;DTHAW=2in; GP  
! NTU TUID AREA IROAD ISCOND GRADE ACTRMS RDA USCS KWI RCI1 RCI2 DBROCK  
62 'st-17' 1.00 0 1 0 0.0 999 GP 5 150 150 99  
! DSNOW SIGMA DFREEZ DTHAW TMOIST ICE  
WIN 0.0 0.2 12.0 2.0 0.0 0  
!  
! 63) SOIL TEST#18: KWI=5, RCI1,2=150, DFREEZE=12in;DTHAW=2in; GM  
! NTU TUID AREA IROAD ISCOND GRADE ACTRMS RDA USCS KWI RCI1 RCI2 DBROCK  
63 'st-18' 1.00 0 1 0 0.0 999 GM 5 150 150 99  
! DSNOW SIGMA DFREEZ DTHAW TMOIST ICE  
WIN 0.0 0.2 12.0 2.0 0.0 0  
!  
! 64) SOIL TEST#19: KWI=5, RCI1,2=150, DFREEZE=12in;DTHAW=2in; GC  
! NTU TUID AREA IROAD ISCOND GRADE ACTRMS RDA USCS KWI RCI1 RCI2 DBROCK  
64 'st-19' 1.00 0 1 0 0.0 999 GC 5 150 150 99  
! DSNOW SIGMA DFREEZ DTHAW TMOIST ICE  
WIN 0.0 0.2 12.0 2.0 0.0 0  
!  
! 65) SOIL TEST#20: KWI=5, RCI1,2=150, DFREEZE=12in;DTHAW=2in; Pt  
! NTU TUID AREA IROAD ISCOND GRADE ACTRMS RDA USCS KWI RCI1 RCI2 DBROCK  
65 'st-20' 1.00 0 1 0 0.0 999 Pt 5 150 150 99  
! DSNOW SIGMA DFREEZ DTHAW TMOIST ICE  
WIN 0.0 0.2 12.0 2.0 0.0 0  
!  
! 66) #2SOIL TEST#1: KWI=0, RCI1,2=150, DFREEZE=12in;DTHAW=2in; SW  
! NTU TUID AREA IROAD ISCOND GRADE ACTRMS RDA USCS KWI RCI1 RCI2 DBROCK  
66 '2st-1' 1.00 0 1 0 0.0 999 SW 0 150 150 99  
! DSNOW SIGMA DFREEZ DTHAW TMOIST ICE  
WIN 0.0 0.2 12.0 2.0 40.0 0  
!  
! 67) #2SOIL TEST#2: KWI=0, RCI1,2=150, DFREEZE=12in;DTHAW=2in; SP  
! NTU TUID AREA IROAD ISCOND GRADE ACTRMS RDA USCS KWI RCI1 RCI2 DBROCK  
67 '2st-2' 1.00 0 1 0 0.0 999 SP 0 150 150 99  
! DSNOW SIGMA DFREEZ DTHAW TMOIST ICE  
WIN 0.0 0.2 12.0 2.0 40.0 0  
!

! 68) #2SOIL TEST#3: KWI=0, RCI1,2=150, DFREEZE=12in;DTHAW=2in; SM  
! NTU TUID AREA IROAD ISCOND GRADE ACTRMS RDA USCS KWI RCI1 RCI2 DBROCK  
68 '2st-3' 1.00 0 1 0 0.0999 SW 0 150 150 99  
! DSNOW SIGMA DFREEZ DTHAW TMOIST ICE  
WIN 0.0 0.2 12.0 2.0 40.0 0  
!  
! 69) #2SOIL TEST#4: KWI=0, RCI1,2=150, DFREEZE=12in;DTHAW=2in; SC  
! NTU TUID AREA IROAD ISCOND GRADE ACTRMS RDA USCS KWI RCI1 RCI2 DBROCK  
69 '2st-4' 1.00 0 1 0 0.0999 SC 0 150 150 99  
! DSNOW SIGMA DFREEZ DTHAW TMOIST ICE  
WIN 0.0 0.2 12.0 2.0 40.0 0  
!  
! 70) #2SOIL TEST#5: KWI=0, RCI1,2=150, DFREEZE=12in;DTHAW=2in; SMSC  
! NTU TUID AREA IROAD ISCOND GRADE ACTRMS RDA USCS KWI RCI1 RCI2 DBROCK  
70 '2st-5' 1.00 0 1 0 0.0999 SMSC 0 150 150 99  
! DSNOW SIGMA DFREEZ DTHAW TMOIST ICE  
WIN 0.0 0.2 12.0 2.0 40.0 0  
!  
! 71) #2SOIL TEST#6: KWI=0, RCI1,2=150, DFREEZE=12in;DTHAW=2in; CL  
! NTU TUID AREA IROAD ISCOND GRADE ACTRMS RDA USCS KWI RCI1 RCI2 DBROCK  
71 '2st-6' 1.00 0 1 0 0.0999 CL 0 150 150 99  
! DSNOW SIGMA DFREEZ DTHAW TMOIST ICE  
WIN 0.0 0.2 12.0 2.0 40.0 0  
!  
! 72) #2SOIL TEST#7: KWI=0, RCI1,2=150, DFREEZE=12in;DTHAW=2in; ML  
! NTU TUID AREA IROAD ISCOND GRADE ACTRMS RDA USCS KWI RCI1 RCI2 DBROCK  
72 '2st-7' 1.00 0 1 0 0.0999 ML 0 150 150 99  
! DSNOW SIGMA DFREEZ DTHAW TMOIST ICE  
WIN 0.0 0.2 12.0 2.0 40.0 0  
!! 73) #2SOIL TEST#8: KWI=0, RCI1,2=150, DFREEZE=12in;DTHAW=2in; CLML  
! NTU TUID AREA IROAD ISCOND GRADE ACTRMS RDA USCS KWI RCI1 RCI2 DBROCK  
73 '2st-8' 1.00 0 1 0 0.0999 CLML 0 150 150 99  
! DSNOW SIGMA DFREEZ DTHAW TMOIST ICE  
WIN 0.0 0.2 12.0 2.0 40.0 0  
!  
! 74) #2SOIL TEST#9: KWI=0, RCI1,2=150, DFREEZE=12in;DTHAW=2in; CH  
! NTU TUID AREA IROAD ISCOND GRADE ACTRMS RDA USCS KWI RCI1 RCI2 DBROCK  
74 '2st-9' 1.00 0 1 0 0.0999 CH 0 150 150 99  
! DSNOW SIGMA DFREEZ DTHAW TMOIST ICE  
WIN 0.0 0.2 12.0 2.0 40.0 0  
!  
! 75) #2SOIL TEST#10: KWI=0, RCI1,2=150, DFREEZE=12in;DTHAW=2in; MH  
! NTU TUID AREA IROAD ISCOND GRADE ACTRMS RDA USCS KWI RCI1 RCI2 DBROCK  
75 '2st-10' 1.00 0 1 0 0.0999 MH 0 150 150 99  
! DSNOW SIGMA DFREEZ DTHAW TMOIST ICE  
WIN 0.0 0.2 12.0 2.0 40.0 0  
!  
! 76) #2SOIL TEST#11: KWI=0, RCI1,2=150, DFREEZE=12in;DTHAW=2in; OL  
! NTU TUID AREA IROAD ISCOND GRADE ACTRMS RDA USCS KWI RCI1 RCI2 DBROCK  
76 '2st-3' 1.00 0 1 0 0.0999 OL 0 150 150 99  
! DSNOW SIGMA DFREEZ DTHAW TMOIST ICE  
WIN 0.0 0.2 12.0 2.0 40.0 0  
!  
! 77) #2SOIL TEST#12: KWI=0, RCI1,2=150, DFREEZE=12in;DTHAW=2in; OH  
! NTU TUID AREA IROAD ISCOND GRADE ACTRMS RDA USCS KWI RCI1 RCI2 DBROCK  
77 '2st-12' 1.00 0 1 0 0.0999 OH 0 150 150 99  
! DSNOW SIGMA DFREEZ DTHAW TMOIST ICE  
WIN 0.0 0.2 12.0 2.0 40.0 0  
!  
! 78) #2SOIL TEST#13: KWI=0, RCI1,2=150, DFREEZE=12in;DTHAW=2in; WATR  
! NTU TUID AREA IROAD ISCOND GRADE ACTRMS RDA USCS KWI RCI1 RCI2 DBROCK  
78 '2st-13' 1.00 0 1 0 0.0999 WATR 0 150 150 99  
! DSNOW SIGMA DFREEZ DTHAW TMOIST ICE  
WIN 0.0 0.2 12.0 2.0 40.0 0  
!

! 79) #2SOIL TEST#14: KWI=0, RCI1,2=150, DFREEZE=12in;DTHAW=2in; PAVE  
! NTU TUID AREA IROAD ISCOND GRADE ACTRMS RDA USCS KWI RCI1 RCI2 DBROCK  
79 '2st-14' 1.00 0 1 0 0.0999 PAVE 0 150 150 99  
! DSNOW SIGMA DFREEZ DTHAW TMOIST ICE  
WIN 0.0 0.2 12.0 2.0 40.0 0  
!  
! 80) #2SOIL TEST#15: KWI=0, RCI1,2=150, DFREEZE=12in;DTHAW=2in; ROCK  
! NTU TUID AREA IROAD ISCOND GRADE ACTRMS RDA USCS KWI RCI1 RCI2 DBROCK  
80 '2st-15' 1.00 0 1 0 0.0999 ROCK 0 150 150 99  
! DSNOW SIGMA DFREEZ DTHAW TMOIST ICE  
WIN 0.0 0.2 12.0 2.0 40.0 0  
!  
! 81) #2SOIL TEST#16: KWI=0, RCI1,2=150, DFREEZE=12in;DTHAW=2in; GW  
! NTU TUID AREA IROAD ISCOND GRADE ACTRMS RDA USCS KWI RCI1 RCI2 DBROCK  
81 '2st-16' 1.00 0 1 0 0.0999 GW 0 150 150 99  
! DSNOW SIGMA DFREEZ DTHAW TMOIST ICE  
WIN 0.0 0.2 12.0 2.0 40.0 0  
!  
! 82) #2SOIL TEST#17: KWI=0, RCI1,2=150, DFREEZE=12in;DTHAW=2in; GP  
! NTU TUID AREA IROAD ISCOND GRADE ACTRMS RDA USCS KWI RCI1 RCI2 DBROCK  
82 '2st-17' 1.00 0 1 0 0.0999 GP 0 150 150 99  
! DSNOW SIGMA DFREEZ DTHAW TMOIST ICE  
WIN 0.0 0.2 12.0 2.0 40.0 0  
!  
! 83) #2SOIL TEST#18: KWI=0, RCI1,2=150, DFREEZE=12in;DTHAW=2in; GM  
! NTU TUID AREA IROAD ISCOND GRADE ACTRMS RDA USCS KWI RCI1 RCI2 DBROCK  
83 '2st-18' 1.00 0 1 0 0.0999 GM 0 150 150 99  
! DSNOW SIGMA DFREEZ DTHAW TMOIST ICE  
WIN 0.0 0.2 12.0 2.0 40.0 0  
!  
! 84) #2SOIL TEST#19: KWI=0, RCI1,2=150, DFREEZE=12in;DTHAW=2in; GC  
! NTU TUID AREA IROAD ISCOND GRADE ACTRMS RDA USCS KWI RCI1 RCI2 DBROCK  
84 '2st-19' 1.00 0 1 0 0.0999 GC 0 150 150 99  
! DSNOW SIGMA DFREEZ DTHAW TMOIST ICE  
WIN 0.0 0.2 12.0 2.0 40.0 0  
!! 85) #2SOIL TEST#20: KWI=0, RCI1,2=150, DFREEZE=12in;DTHAW=2in; Pt  
! NTU TUID AREA IROAD ISCOND GRADE ACTRMS RDA USCS KWI RCI1 RCI2 DBROCK  
85 '2st-20' 1.00 0 1 0 0.0999 Pt 0 150 150 99  
! DSNOW SIGMA DFREEZ DTHAW TMOIST ICE  
WIN 0.0 0.2 12.0 2.0 40.0 0  
!  
! 86) 0-in snow on 4-in thawing ground, 5% moisture content  
! NTU TUID AREA IROAD ISCOND GRADE ACTRMS RDA USCS KWI RCI1 RCI2 DBROCK  
86 '4thM5' 1.00 0 1 0 0.0999 SM 3 50 50 99  
! DSNOW SIGMA DFREEZ DTHAW TMOIST ICE  
WIN 0.0 0.2 12.0 4.0 5.0 0  
!  
! 87) 0-in snow on 4-in thawing ground, 10% moisture content  
! NTU TUID AREA IROAD ISCOND GRADE ACTRMS RDA USCS KWI RCI1 RCI2 DBROCK  
87 '4thM10' 1.00 0 1 0 0.0999 SM 3 50 50 99  
! DSNOW SIGMA DFREEZ DTHAW TMOIST ICE  
WIN 0.0 0.2 12.0 4.0 10.0 0  
!  
! 88) 0-in snow on 4-in thawing ground, 30% moisture content  
! NTU TUID AREA IROAD ISCOND GRADE ACTRMS RDA USCS KWI RCI1 RCI2 DBROCK  
88 '4thM30' 1.00 0 1 0 0.0999 SM 3 50 50 99  
! DSNOW SIGMA DFREEZ DTHAW TMOIST ICE  
WIN 0.0 0.2 12.0 4.0 30.0 0  
!  
! 89) 0-in snow on 4-in thawing ground, 50% moisture content  
! NTU TUID AREA IROAD ISCOND GRADE ACTRMS RDA USCS KWI RCI1 RCI2 DBROCK  
89 '4thM10' 1.00 0 1 0 0.0999 SM 3 50 50 99  
! DSNOW SIGMA DFREEZ DTHAW TMOIST ICE  
WIN 0.0 0.2 12.0 4.0 50.0 0  
!

! 90) 0-in snow on 2-in thawing ground, RCI1,2=5  
! NTU TUID AREA IROAD ISCOND GRADE ACTRMS RDA USCS KWI RCI1 RCI2 DBROCK  
90 '2thR5' 1.00 0 1 0 0.0999 SM 3 5 5 99  
! DSNOW SIGMA DFREEZ DTHAW TMOIST ICE  
WIN 0.0 0.2 12.0 2.0 0.0 0  
!  
! 91) 0-in snow on 2-in thawing ground, RCI1,2=20  
! NTU TUID AREA IROAD ISCOND GRADE ACTRMS RDA USCS KWI RCI1 RCI2 DBROCK  
91 '2thR20' 1.00 0 1 0 0.0999 SM 3 20 20 99  
! DSNOW SIGMA DFREEZ DTHAW TMOIST ICE  
WIN 0.0 0.2 12.0 2.0 0.0 0  
!  
! 92) 0-in snow on 2-in thawing ground, RCI1,2=150  
! NTU TUID AREA IROAD ISCOND GRADE ACTRMS RDA USCS KWI RCI1 RCI2 DBROCK  
92 '2thR150' 1.00 0 1 0 0.0999 SM 3 150 10 99  
! DSNOW SIGMA DFREEZ DTHAW TMOIST ICE  
WIN 0.0 0.2 12.0 2.0 0.0 0  
!  
20 8 Checkout terrain for CRREL winter effects model 22 July 94  
!  
! 93) SOIL TEST#1: KWI=5, RCI1,2=150, DFREEZE=12in;DTHAW=2in; SW  
! NTU TUID AREA IROAD ISCOND GRADE ACTRMS RDA USCS KWI RCI1 RCI2 DBROCK  
93 'st-1' 1.00 0 1 0 0.0999 SW 5 150 150 99  
! DSNOW SIGMA DFREEZ DTHAW TMOIST ICE  
WIN 0.0 0.2 0.0 0.0 0.0 0  
!  
! 94) SOIL TEST#2: KWI=5, RCI1,2=150, DFREEZE=12in;DTHAW=2in; SP  
! NTU TUID AREA IROAD ISCOND GRADE ACTRMS RDA USCS KWI RCI1 RCI2 DBROCK  
94 'st-2' 1.00 0 1 0 0.0999 SP 5 150 150 99  
! DSNOW SIGMA DFREEZ DTHAW TMOIST ICE  
WIN 0.0 0.2 0.0 0.0 0.0 0  
!  
! 95) SOIL TEST#3: KWI=5, RCI1,2=150, DFREEZE=12in;DTHAW=2in; SM  
! NTU TUID AREA IROAD ISCOND GRADE ACTRMS RDA USCS KWI RCI1 RCI2 DBROCK  
95 'st-3' 1.00 0 1 0 0.0999 SW 5 150 150 99  
! DSNOW SIGMA DFREEZ DTHAW TMOIST ICE  
WIN 0.0 0.2 0.0 0.0 0.0 0  
!  
! 96) SOIL TEST#4: KWI=5, RCI1,2=150, DFREEZE=12in;DTHAW=2in; SC  
! NTU TUID AREA IROAD ISCOND GRADE ACTRMS RDA USCS KWI RCI1 RCI2 DBROCK  
96 'st-4' 1.00 0 1 0 0.0999 SC 5 150 150 99  
! DSNOW SIGMA DFREEZ DTHAW TMOIST ICE  
WIN 0.0 0.2 0.0 0.0 0.0 0  
!  
! 97) SOIL TEST#5: KWI=5, RCI1,2=150, DFREEZE=12in;DTHAW=2in; SMSC  
! NTU TUID AREA IROAD ISCOND GRADE ACTRMS RDA USCS KWI RCI1 RCI2 DBROCK  
97 'st-5' 1.00 0 1 0 0.0999 SMSC 5 150 150 99  
! DSNOW SIGMA DFREEZ DTHAW TMOIST ICE  
WIN 0.0 0.2 0.0 0.0 0.0 0  
!  
! 98) SOIL TEST#6: KWI=5, RCI1,2=150, DFREEZE=12in;DTHAW=2in; CL  
! NTU TUID AREA IROAD ISCOND GRADE ACTRMS RDA USCS KWI RCI1 RCI2 DBROCK  
98 'st-6' 1.00 0 1 0 0.0999 CL 5 150 150 99  
! DSNOW SIGMA DFREEZ DTHAW TMOIST ICE  
WIN 0.0 0.2 0.0 0.0 0.0 0  
!  
! 99) SOIL TEST#7: KWI=5, RCI1,2=150, DFREEZE=12in;DTHAW=2in; ML  
! NTU TUID AREA IROAD ISCOND GRADE ACTRMS RDA USCS KWI RCI1 RCI2 DBROCK  
99 'st-7' 1.00 0 1 0 0.0999 ML 5 150 150 99  
! DSNOW SIGMA DFREEZ DTHAW TMOIST ICE  
WIN 0.0 0.2 0.0 0.0 0.0 0  
!

!100) SOIL TEST#8: KWI=5, RCI1,2=150, DFREEZE=12in;DTHAW=2in; CLML  
! NTU TUID AREA IROAD ISCOND GRADE ACTRMS RDA USCS KWI RCI1 RCI2 DBROCK  
100 'st-8' 1.00 0 1 0 0.0999 CLML 5 150 150 99  
! DSNOW SIGMA DFREEZ DTHAW TMOIST ICE  
WIN 0.0 0.2 0.0 0.0 0.0 0  
!  
!101) SOIL TEST#9: KWI=5, RCI1,2=150, DFREEZE=12in;DTHAW=2in; CH  
! NTU TUID AREA IROAD ISCOND GRADE ACTRMS RDA USCS KWI RCI1 RCI2 DBROCK  
101 'st-9' 1.00 0 1 0 0.0999 CH 5 150 150 99  
! DSNOW SIGMA DFREEZ DTHAW TMOIST ICE  
WIN 0.0 0.2 0.0 0.0 0.0 0  
!  
!102) SOIL TEST#10: KWI=5, RCI1,2=150, DFREEZE=12in;DTHAW=2in; MH  
! NTU TUID AREA IROAD ISCOND GRADE ACTRMS RDA USCS KWI RCI1 RCI2 DBROCK  
102 'st-10' 1.00 0 1 0 0.0999 MH 5 150 150 99  
! DSNOW SIGMA DFREEZ DTHAW TMOIST ICE  
WIN 0.0 0.2 0.0 0.0 0.0 0  
!  
!103) SOIL TEST#11: KWI=5, RCI1,2=150, DFREEZE=12in;DTHAW=2in; OL  
! NTU TUID AREA IROAD ISCOND GRADE ACTRMS RDA USCS KWI RCI1 RCI2 DBROCK  
103 'st-3' 1.00 0 1 0 0.0999 OL 5 150 150 99  
! DSNOW SIGMA DFREEZ DTHAW TMOIST ICE  
WIN 0.0 0.2 0.0 0.0 0.0 0  
!  
!104) SOIL TEST#12: KWI=5, RCI1,2=150, DFREEZE=12in;DTHAW=2in; OH  
! NTU TUID AREA IROAD ISCOND GRADE ACTRMS RDA USCS KWI RCI1 RCI2 DBROCK  
104 'st-12' 1.00 0 1 0 0.0999 OH 5 150 150 99  
! DSNOW SIGMA DFREEZ DTHAW TMOIST ICE  
WIN 0.0 0.2 0.0 0.0 0.0 0  
!  
!105) SOIL TEST#13: KWI=5, RCI1,2=150, DFREEZE=12in;DTHAW=2in; WATR  
! NTU TUID AREA IROAD ISCOND GRADE ACTRMS RDA USCS KWI RCI1 RCI2 DBROCK  
105 'st-13' 1.00 0 1 0 0.0999 WATR 5 150 150 99  
! DSNOW SIGMA DFREEZ DTHAW TMOIST ICE  
WIN 0.0 0.2 0.0 0.0 0.0 0  
!  
!106) SOIL TEST#14: KWI=5, RCI1,2=150, DFREEZE=12in;DTHAW=2in; PAVE  
! NTU TUID AREA IROAD ISCOND GRADE ACTRMS RDA USCS KWI RCI1 RCI2 DBROCK  
106 'st-14' 1.00 0 1 0 0.0999 PAVE 5 150 150 99  
! DSNOW SIGMA DFREEZ DTHAW TMOIST ICE  
WIN 0.0 0.2 0.0 0.0 0.0 0  
!  
!107) SOIL TEST#15: KWI=5, RCI1,2=150, DFREEZE=12in;DTHAW=2in; ROCK  
! NTU TUID AREA IROAD ISCOND GRADE ACTRMS RDA USCS KWI RCI1 RCI2 DBROCK  
107 'st-15' 1.00 0 1 0 0.0999 ROCK 5 150 150 99  
! DSNOW SIGMA DFREEZ DTHAW TMOIST ICE  
WIN 0.0 0.2 0.0 0.0 0.0 0  
!  
!108) SOIL TEST#16: KWI=5, RCI1,2=150, DFREEZE=12in;DTHAW=2in; GW  
! NTU TUID AREA IROAD ISCOND GRADE ACTRMS RDA USCS KWI RCI1 RCI2 DBROCK  
108 'st-16' 1.00 0 1 0 0.0999 GW 5 150 150 99  
! DSNOW SIGMA DFREEZ DTHAW TMOIST ICE  
WIN 0.0 0.2 0.0 0.0 0.0 0  
!  
!109) SOIL TEST#17: KWI=5, RCI1,2=150, DFREEZE=12in;DTHAW=2in; GP  
! NTU TUID AREA IROAD ISCOND GRADE ACTRMS RDA USCS KWI RCI1 RCI2 DBROCK  
109 'st-17' 1.00 0 1 0 0.0999 GP 5 150 150 99  
! DSNOW SIGMA DFREEZ DTHAW TMOIST ICE  
WIN 0.0 0.2 0.0 0.0 0.0 0  
!  
!110) SOIL TEST#18: KWI=5, RCI1,2=150, DFREEZE=12in;DTHAW=2in; GM  
! NTU TUID AREA IROAD ISCOND GRADE ACTRMS RDA USCS KWI RCI1 RCI2 DBROCK  
110 'st-18' 1.00 0 1 0 0.0999 GM 5 150 150 99  
! DSNOW SIGMA DFREEZ DTHAW TMOIST ICE  
WIN 0.0 0.2 0.0 0.0 0.0 0  
!

!111) SOIL TEST#19: KWI=5, RCI1,2=150, DFREEZE=12in;DTHAW=2in; GC  
! NTU TUID AREA IROAD ISCOND GRADE ACTRMS RDA USCS KWI RCI1 RCI2 DBROCK  
111 'st-19' 1.00 0 1 0 0.0 999 GC 5 150 150 99  
! DSNOW SIGMA DFREEZ DTHAW TMOIST ICE  
WIN 0.0 0.2 0.0 0.0 0.0 0  
!  
!112) SOIL TEST#20: KWI=5, RCI1,2=150, DFREEZE=12in;DTHAW=2in; Pt  
! NTU TUID AREA IROAD ISCOND GRADE ACTRMS RDA USCS KWI RCI1 RCI2 DBROCK  
112 'st-20' 1.00 0 1 0 0.0 999 Pt 5 150 150 99  
! DSNOW SIGMA DFREEZ DTHAW TMOIST ICE  
WIN 0.0 0.2 0.0 0.0 0.0 0

TERRAIN UNIT OUTPUT

29-JUL-94 11:17:54 NRRMII version 2.5.0 last changed 12 May, 1994

TERRAIN 1 FILE=crrelcko.ter  
 38 UNITS, ID=Checkout terrain for CRREL winter effects model 6 Ma  
 SCENARIO 1 FILE=scenario.dat  
 "CRRELSNOW " ID=Dry,Snow,January (CRREL model)  
 VEHICLE 1 FILE=vehicles/ml13.crl  
 ID= M113 FOR CRREL MODEL CHECKOUT 3 MAY 94

Snow model:CRREL

Weight [Lb]: 2@ 11700 = 23401

NTU/	-----Gross-(soil only)-[Lb]-----				----Total-[Lb]-		Speed		
IBASE	Traction	Resist.	drawbar	DB-Coeff.	Tractn.	Resist.	[MPH]	TFmul1	MRmul1
Snow depth= 10.0	in	Density= 0.1	g/cm <sup>3</sup>	Slope= 0.0	deg				
1 0	9360.1	9360.9	-0.8	0.0000	2340	877	29.8		
2 0	18397.1	1636.4	16760.7	0.7162	17950	1636	34.3		
3 0	17905.0	2043.8	15861.2	0.6778	17904	2043	20.9		
4 0	17049.3	2765.5	14283.8	0.6104	17049	2765	19.7		
5 0	13118.3	6326.7	6791.6	0.2902	13118	6326	8.2		
Snow depth= 0.0	in	Density= 0.2	g/cm <sup>3</sup>	Slope= 0.0	deg				
6 4	2340.1	1228.6	1111.5	0.0475	2340	1228	37.4		
Snow depth= 1.0	in	Density= 0.2	g/cm <sup>3</sup>	Slope= 0.0	deg				
7 4	2340.1	1228.6	1111.5	0.0475	2340	1228	37.4		
Snow depth= 10.0	in	Density= 0.2	g/cm <sup>3</sup>	Slope= 0.0	deg				
8 4	3763.6	2314.2	1449.4	0.0619	3763	2314	18.7		
Snow depth= 1.0	in	Density= 0.2	g/cm <sup>3</sup>	Slope= 0.0	deg				
9 2	9921.9	1388.0	8533.8	0.3647	9921	1388	39.0		
Snow depth= 10.0	in	Density= 0.2	g/cm <sup>3</sup>	Slope= 0.0	deg				
10 2	9921.9	2314.2	7607.7	0.3251	9921	2314	20.3		
Snow depth= 20.0	in	Density= 0.2	g/cm <sup>3</sup>	Slope= 0.0	deg				
11 2	9921.9	3162.4	6759.4	0.2889	9921	3162	16.9		
Snow depth= 10.0	in	Density= 0.1	g/cm <sup>3</sup>	Slope= 0.0	deg				
12 2	9921.9	2003.0	7918.9	0.3384	9921	2002	20.5		
Snow depth= 10.0	in	Density= 0.3	g/cm <sup>3</sup>	Slope= 0.0	deg				
13 2	9921.9	2314.2	7607.7	0.3251	9921	2314	20.3		
Snow depth= 10.0	in	Density= 0.4	g/cm <sup>3</sup>	Slope= 0.0	deg				
14 2	9921.9	2003.0	7918.9	0.3384	9921	2002	20.5		
Snow depth= 10.0	in	Density= 0.2	g/cm <sup>3</sup>	Slope= 0.0	deg				
15 1	9921.9	1963.2	7958.7	0.3401	2340	1963	16.5		
16 3	9921.9	2407.2	7514.6	0.3211	9921	2407	20.3		
17 3	9921.9	2479.9	7442.0	0.3180	9921	2479	20.2		
18 3	9921.9	2910.1	7011.8	0.2996	9921	2910	18.5		
19 2	9921.9	2314.2	7607.7	0.3251	9921	2314	20.3		
20 2	9921.9	2314.2	7607.7	0.3251	9921	2314	20.3		
21 2	9921.9	2314.2	7607.7	0.3251	9921	2314	20.3		
22 2	9921.9	2314.2	7607.7	0.3251	9921	2314	20.3		
23 3	9921.9	2479.9	7442.0	0.3180	9921	2479	20.2		
24 3	9921.9	2910.1	7011.8	0.2996	9921	2910	18.5		
25 3	9921.9	2479.9	7442.0	0.3180	9921	2479	20.2		
26 3	9921.9	2479.9	7442.0	0.3180	9921	2479	20.2		
27 3	9921.9	2479.9	7442.0	0.3180	9921	2479	20.2		
28 3	9921.9	2479.9	7442.0	0.3180	9921	2479	20.2		
Snow depth= 0.0	in	Density= 0.2	g/cm <sup>3</sup>	Slope= 0.0	deg				
29 0	18397.1	1636.4	16760.7	0.7162	17950	1636	34.3		
30 0	18397.1	1636.4	16760.7	0.7162	17950	1636	34.3		
31 0	18397.1	1636.4	16760.7	0.7162	17950	1636	34.3		
32 0	18397.1	1636.4	16760.7	0.7162	17950	1636	34.3		
33 0	17049.3	2765.5	14283.8	0.6104	17049	2765	19.7		
34 0	8422.5	60120.7	-51698.2	-2.2092	8422	60120	0.0	0.642	9.503
35 0	17049.3	2765.5	14283.8	0.6104	17049	2765	19.7		
36 0	17049.3	2765.5	14283.8	0.6104	17049	2765	19.7		
37 0	17049.3	2765.5	14283.8	0.6104	17049	2765	19.7		
38 0	17049.3	2765.5	14283.8	0.6104	17049	2765	19.7		

29-JUL-94 11:18:02 NRMII version 2.5.0 last changed 12 May, 1994

TERRAIN 1 FILE=crrelcko.ter

38 UNITS, ID=Checkout terrain for CRREL winter effects model 6 Ma

SCENARIO 1 FILE=scenario.dat

"CRRELSNOW " ID=Dry,Snow,January (CRREL model)

VEHICLE 2 FILE=vehicles/hmmwv.crl

ID= HMMWV, M998, 4X4 FOR CRREL SNOW MODEL CHECKOUT 3 MAY 94

Snow model:CRREL

Weight [Lb]: 2@ 1625 + 2@ 2135 = 7520

NTU/	-----Gross-(soil only)-[Lb]-----	-----Total-[Lb]-	Speed							
IBASE	Traction	Resist.	drawbar	DB-Coeff.	Tractn.	Resist.	[MPH]	TFmul1	MRmul1	T
Snow depth= 10.0	in	Density= 0.1	g/cm <sup>3</sup>	Slope= 0.0	deg					
1 0	2924.6	2924.5	0.1	0.0000	752	86	29.8			
2 0	4554.9	481.7	4073.3	0.5417	4554	481	40.0			
3 0	4462.7	659.4	3803.4	0.5058	4462	659	40.0			
4 0	4237.4	944.1	3293.3	0.4379	4237	944	35.6			
5 0	3142.0	3189.6	-47.6	-0.0063	3142	3189	0.0			
Snow depth= 0.0	in	Density= 0.2	g/cm <sup>3</sup>	Slope= 0.0	deg					
6 4	752.0	131.6	620.4	0.0825	752	131	40.0			
Snow depth= 1.0	in	Density= 0.2	g/cm <sup>3</sup>	Slope= 0.0	deg					
7 4	752.0	131.6	620.4	0.0825	752	131	40.0			
Snow depth= 10.0	in	Density= 0.2	g/cm <sup>3</sup>	Slope= 0.0	deg					
8 4	1243.7	1245.5	-1.8	-0.0002	1243	1245	0.0			
Snow depth= 1.0	in	Density= 0.2	g/cm <sup>3</sup>	Slope= 0.0	deg					
9 2	2937.2	510.4	2426.8	0.3227	2937	510	40.0			
Snow depth= 10.0	in	Density= 0.2	g/cm <sup>3</sup>	Slope= 0.0	deg					
10 2	2937.2	1245.5	1691.7	0.2250	2937	1245	27.5			
Snow depth= 20.0	in	Density= 0.2	g/cm <sup>3</sup>	Slope= 0.0	deg					
11 2	2937.2	2504.4	432.8	0.0576	2937	2504	10.3			
Snow depth= 10.0	in	Density= 0.1	g/cm <sup>3</sup>	Slope= 0.0	deg					
12 2	2937.2	813.1	2124.1	0.2825	2937	813	40.0			
Snow depth= 10.0	in	Density= 0.3	g/cm <sup>3</sup>	Slope= 0.0	deg					
13 2	2937.2	1458.8	1478.4	0.1966	2937	1458	26.4			
Snow depth= 10.0	in	Density= 0.4	g/cm <sup>3</sup>	Slope= 0.0	deg					
14 2	2937.2	1377.2	1560.0	0.2074	2937	1377	26.9			
Snow depth= 10.0	in	Density= 0.2	g/cm <sup>3</sup>	Slope= 0.0	deg					
15 1	2937.2	1226.7	1710.5	0.2275	752	1226	0.0			
16 3	2937.2	1255.2	1682.0	0.2237	2937	1255	27.5			
17 3	2937.2	1304.5	1632.7	0.2171	2937	1304	27.2			
18 3	2937.2	1499.2	1437.9	0.1912	2937	1499	26.2			
19 2	2937.2	1245.5	1691.7	0.2250	2937	1245	27.5			
20 2	2937.2	1245.5	1691.7	0.2250	2937	1245	27.5			
21 2	2937.2	1245.5	1691.7	0.2250	2937	1245	27.5			
22 2	2937.2	1245.5	1691.7	0.2250	2937	1245	27.5			
23 3	2937.2	1304.5	1632.7	0.2171	2937	1304	27.2			
24 3	2937.2	1499.2	1437.9	0.1912	2937	1499	26.2			
25 3	2937.2	1304.5	1632.7	0.2171	2937	1304	27.2			
26 3	2937.2	1304.5	1632.7	0.2171	2937	1304	27.2			
27 3	2937.2	1304.5	1632.7	0.2171	2937	1304	27.2			
28 3	2937.2	1304.5	1632.7	0.2171	2937	1304	27.2			
Snow depth= 0.0	in	Density= 0.2	g/cm <sup>3</sup>	Slope= 0.0	deg					
29 0	4554.9	481.7	4073.3	0.5417	4554	481	40.0			
30 0	4554.9	481.7	4073.3	0.5417	4554	481	40.0			
31 0	4554.9	481.7	4073.3	0.5417	4554	481	40.0			
32 0	4554.9	481.7	4073.3	0.5417	4554	481	40.0			
33 0	4237.4	944.1	3293.3	0.4379	4237	944	35.6			
34 0	4237.4	944.1	3293.3	0.4379	4237	944	35.6			
35 0	4237.4	944.1	3293.3	0.4379	4237	944	35.6			
36 0	4237.4	944.1	3293.3	0.4379	4237	944	35.6			
37 0	4237.4	944.1	3293.3	0.4379	4237	944	35.6			
38 0	4237.4	944.1	3293.3	0.4379	4237	944	35.6			

TERRAIN 1 FILE=crrelcko2.ter

54 UNITS, ID=Checkout terrain for CRREL winter effects model 6 Ma

SCENARIO 1 FILE=scenario.dat

"CRRELSNOW " ID=Dry,Snow,January (CRREL model)

VEHICLE 1 FILE=vehicles/m113.crl

ID= M113 FOR CRREL MODEL CHECKOUT 3 MAY 94

Snow model:CRREL

Weight [Lb]: 2@ 11700 = 23401

NTU/	-----Gross-(soil only)-[Lb]-----				----Total-[Lb]-		Speed		
IBASE	Traction	Resist.	drawbar	DB-Coeff.	Tractn.	Resist.	[MPH]	TFmull	MRmull
Snow depth=	0.0	in	Density=	0.2	g/cm <sup>3</sup>	Slope=	0.0	deg	
39 0	9360.1	9360.9	-0.8	0.0000	9360	9360	0.0		
40 0	18397.1	1636.4	16760.7	0.7162	17950	1636	34.3		
41 0	18397.1	1636.4	16760.7	0.7162	17950	1636	34.3		
42 0	-2521.7	23082.5	-25604.1	-1.0941	-2521	23082	0.0		
43 0	18397.1	1636.4	16760.7	0.7162	17950	1636	34.3		
44 0	18397.1	1636.4	16760.7	0.7162	17950	1636	34.3		
45 0	12125.3	19540.4	-7415.1	-0.3169	12125	19540	0.0	0.711	7.066
46 0	8947.0	23975.3	-15028.3	-0.6422	9910	23975	0.0	0.711	7.066
47 0	8947.0	23975.3	-15028.3	-0.6422	9910	23975	0.0	0.711	7.066
48 0	8947.0	23975.3	-15028.3	-0.6422	9910	23975	0.0	0.711	7.066
49 0	12747.3	11302.5	1444.8	0.0617	12747	11302	1.7	0.711	7.066
50 0	12913.7	12956.0	-42.3	-0.0018	12913	12955	0.0	0.711	7.066
51 0	18158.0	1833.6	16324.4	0.6976	12045	1833	23.0		
52 0	12747.3	11302.5	1444.8	0.0617	12747	11302	1.7	0.711	7.066
53 0	18158.0	1833.6	16324.4	0.6976	12045	1833	23.0		
54 0	18158.0	1833.6	16324.4	0.6976	9217	1833	22.9		
55 0	18158.0	1833.6	16324.4	0.6976	9217	1833	22.9		
56 0	18158.0	1833.6	16324.4	0.6976	12045	1833	23.0		
57 0	18158.0	1833.6	16324.4	0.6976	9217	1833	22.9		
58 0	0.02316699.0	*****	-99.0000		2340	2316699	0.0		
59 0	0.02316699.0	*****	-99.0000		2340	2316699	0.0		
60 0	12747.3	11302.5	1444.8	0.0617	12747	11302	1.7	0.711	7.066
61 0	8947.0	23975.3	-15028.3	-0.6422	9910	23975	0.0	0.711	7.066
62 0	8947.0	23975.3	-15028.3	-0.6422	9910	23975	0.0	0.711	7.066
63 0	12913.7	12956.0	-42.3	-0.0018	12913	12955	0.0	0.711	7.066
64 0	12747.3	11302.5	1444.8	0.0617	12747	11302	1.7	0.711	7.066
65 0	12296.6	10346.2	1950.4	0.0833	13817	10346	2.5	0.711	7.066
66 0	8947.0	23975.3	-15028.3	-0.6422	9910	23975	0.0	0.711	7.066
67 0	8947.0	23975.3	-15028.3	-0.6422	9910	23975	0.0	0.711	7.066
68 0	8947.0	23975.3	-15028.3	-0.6422	9910	23975	0.0	0.711	7.066
69 0	12747.3	11302.5	1444.8	0.0617	12747	11302	1.7	0.711	7.066
70 0	12913.7	12956.0	-42.3	-0.0018	12913	12955	0.0	0.711	7.066
71 0	18158.0	1833.6	16324.4	0.6976	12045	1833	23.0		
72 0	12747.3	11302.5	1444.8	0.0617	12747	11302	1.7	0.711	7.066
73 0	18158.0	1833.6	16324.4	0.6976	12045	1833	23.0		
74 0	18158.0	1833.6	16324.4	0.6976	9217	1833	22.9		
75 0	18158.0	1833.6	16324.4	0.6976	9217	1833	22.9		
76 0	18158.0	1833.6	16324.4	0.6976	12045	1833	23.0		
77 0	18158.0	1833.6	16324.4	0.6976	9217	1833	22.9		
78 0	0.02316699.0	*****	-99.0000		2340	2316699	0.0		
79 0	0.02316699.0	*****	-99.0000		2340	2316699	0.0		
80 0	12747.3	11302.5	1444.8	0.0617	12747	11302	1.7	0.711	7.066
81 0	8947.0	23975.3	-15028.3	-0.6422	9910	23975	0.0	0.711	7.066
82 0	8947.0	23975.3	-15028.3	-0.6422	9910	23975	0.0	0.711	7.066
83 0	12913.7	12956.0	-42.3	-0.0018	12913	12955	0.0	0.711	7.066
84 0	12747.3	11302.5	1444.8	0.0617	12747	11302	1.7	0.711	7.066
85 0	17290.2	1464.3	15826.0	0.6763	17950	1464	38.2		
86 0	17049.3	2765.5	14283.8	0.6104	17049	2765	19.7		
87 0	17049.3	2765.5	14283.8	0.6104	17049	2765	19.7		
88 0	10946.5	26279.6	-15333.2	-0.6552	10946	26279	0.0	0.642	9.503
89 0	10946.5	26279.6	-15333.2	-0.6552	10946	26279	0.0	0.642	9.503
90 0	-2521.7	23082.5	-25604.1	-1.0941	-2521	23082	0.0		
91 0	13118.3	6326.7	6791.6	0.2902	13118	6326	8.2		
92 0	18158.0	1833.6	16324.4	0.6976	17950	1833	22.8		

-----  
 29-JUL-94 11:18:57 NRMMII version 2.5.0 last changed 12 May, 1994  
 TERRAIN 1 FILE=crrelcko2.ter  
 54 UNITS, ID=Checkout terrain for CRREL winter effects model 6 Ma  
 SCENARIO 1 FILE=scenario.dat  
 "CRRELSNOW " ID=Dry,Snow,January (CRREL model)  
 VEHICLE 2 FILE=vehicles/hmmwv.crl  
 ID= HMMWV, M998, 4X4 FOR CRREL SNOW MODEL CHECKOUT 3 MAY 94

Snow model:CRREL

Weight [Lb]: 2@ 1625 + 2@ 2135 = 7520

NTU/	-----Gross-(soil only)-[Lb]-----				----Total-[Lb]-		Speed			
IBASE	Traction	Resist.	drawbar	DB-Coef.	Tractn.	Resist.	[MPH]	TFmull	MRmull	T
Snow depth=	0.0 in	Density=	0.2 g/cm <sup>3</sup>	Slope=	0.0 deg					
39 0	2924.6	2924.5	0.1	0.0000	2924	2924	0.0			
40 0	2924.6	2924.5	0.1	0.0000	2924	2924	0.0			
41 0	4554.9	481.7	4073.3	0.5417	4554	481	40.0			
42 0	1616.7	9306.3	-7689.6	-1.0226	1616	9306	0.0			
43 0	3142.0	3189.6	-47.6	-0.0063	3142	3189	0.0			
44 0	4554.9	481.7	4073.3	0.5417	4554	481	40.0			
45 0	3013.6	6670.6	-3657.0	-0.4863	3013	6670	0.0	0.711	7.066	
46 0	1458.7	2021.2	-562.5	-0.0748	1458	2021	0.0	0.711	7.066	
47 0	1458.7	2021.2	-562.5	-0.0748	1458	2021	0.0	0.711	7.066	
48 0	1458.7	2021.2	-562.5	-0.0748	1458	2021	0.0	0.711	7.066	
49 0	3648.0	3116.7	531.3	0.0707	3647	3116	5.1	0.711	7.066	
50 0	3215.0	4073.1	-858.1	-0.1141	3214	4073	0.0	0.711	7.066	
51 0	5091.8	403.5	4688.3	0.6234	3554	403	40.0			
52 0	3610.5	2744.7	865.8	0.1151	3610	2744	8.6	0.711	7.066	
53 0	5091.8	403.5	4688.3	0.6234	3554	403	40.0			
54 0	5189.6	501.3	4688.3	0.6234	2832	501	40.0			
55 0	5189.6	501.3	4688.3	0.6234	2832	501	40.0			
56 0	5091.8	403.5	4688.3	0.6234	3554	403	40.0			
57 0	5189.6	501.3	4688.3	0.6234	2832	501	40.0			
58 0	0.0	744480.0	-744480.0	-99.0000	752	744480	0.0			
59 0	0.0	744480.0	-744480.0	-99.0000	752	744480	0.0			
60 0	3081.3	2744.7	336.5	0.0448	3081	2744	5.9	0.711	7.066	
61 0	1458.7	2021.2	-562.5	-0.0748	1458	2021	0.0	0.711	7.066	
62 0	1458.7	2021.2	-562.5	-0.0748	1458	2021	0.0	0.711	7.066	
63 0	3215.0	4073.1	-858.1	-0.1141	3214	4073	0.0	0.711	7.066	
64 0	3648.0	3116.7	531.3	0.0707	3647	3116	5.1	0.711	7.066	
65 0	3957.2	3400.4	556.8	0.0740	4446	3400	10.0	0.711	7.066	
66 0	1458.7	2021.2	-562.5	-0.0748	1458	2021	0.0	0.711	7.066	
67 0	1458.7	2021.2	-562.5	-0.0748	1458	2021	0.0	0.711	7.066	
68 0	1458.7	2021.2	-562.5	-0.0748	1458	2021	0.0	0.711	7.066	
69 0	3648.0	3116.7	531.3	0.0707	3647	3116	5.1	0.711	7.066	
70 0	3215.0	4073.1	-858.1	-0.1141	3214	4073	0.0	0.711	7.066	
71 0	5091.8	403.5	4688.3	0.6234	3554	403	40.0			
72 0	3610.5	2744.7	865.8	0.1151	3610	2744	8.6	0.711	7.066	
73 0	5091.8	403.5	4688.3	0.6234	3554	403	40.0			
74 0	5189.6	501.3	4688.3	0.6234	2832	501	40.0			
75 0	5189.6	501.3	4688.3	0.6234	2832	501	40.0			
76 0	5091.8	403.5	4688.3	0.6234	3554	403	40.0			
77 0	5189.6	501.3	4688.3	0.6234	2832	501	40.0			
78 0	0.0	744480.0	-744480.0	-99.0000	752	744480	0.0			
79 0	0.0	744480.0	-744480.0	-99.0000	752	744480	0.0			
80 0	3081.3	2744.7	336.5	0.0448	3081	2744	5.9	0.711	7.066	
81 0	1458.7	2021.2	-562.5	-0.0748	1458	2021	0.0	0.711	7.066	
82 0	1458.7	2021.2	-562.5	-0.0748	1458	2021	0.0	0.711	7.066	
83 0	3215.0	4073.1	-858.1	-0.1141	3214	4073	0.0	0.711	7.066	
84 0	3648.0	3116.7	531.3	0.0707	3647	3116	5.1	0.711	7.066	
85 0	5564.2	481.2	5083.0	0.6759	6053	481	40.0			
86 0	4237.4	944.1	3293.3	0.4379	4237	944	35.6			
87 0	4237.4	944.1	3293.3	0.4379	4237	944	35.6			
88 0	2720.6	8971.3	-6250.6	-0.8312	2720	8971	0.0	0.642	9.503	
89 0	2720.6	8971.3	-6250.6	-0.8312	2720	8971	0.0	0.642	9.503	
90 0	1616.7	9306.3	-7689.6	-1.0226	1616	9306	0.0			
91 0	3142.0	3189.6	-47.6	-0.0063	3142	3189	0.0			
92 0	4520.6	576.5	3944.1	0.5245	4520	576	40.0			

29-JUL-94 11:18:12 NRMII version 2.5.0 last changed 12 May, 1994

TERRAIN 1 FILE=crrelcko3.ter

20 UNITS, ID=Checkout terrain for CRREL winter effects model 22 J

SCENARIO 1 FILE=scenario.dat

"CRRELSNOW " ID=Dry,Snow,January (CRREL model)

VEHICLE 1 FILE=vehicles/m113.crl

ID= M113 FOR CRREL MODEL CHECKOUT 3 MAY 94

Snow model:CRREL

Weight [Lb]: 2@ 11700 = 23401

NTU/	-----Gross-(soil only)-[Lb]-----	-----Total-[Lb]-	Speed
IBASE	Traction Resist. drawbar DB-Coeff. Tractn. Resist. [MPH]	TFmul1 MRmul1	
Snow depth=	0.0 in Density= 0.2 g/cm <sup>3</sup> Slope= 0.0 deg		
93 0	12580.4 3393.1 9187.2 0.3926 13544 3393	15.3	
94 0	12580.4 3393.1 9187.2 0.3926 13544 3393	15.3	
95 0	12580.4 3393.1 9187.2 0.3926 13544 3393	15.3	
96 0	17924.0 1599.6 16324.4 0.6976 17923 1599	35.1	
97 0	18158.0 1833.6 16324.4 0.6976 17950 1833	22.8	
98 0	17924.0 1599.6 16324.4 0.6976 17923 1599	35.2	
99 0	17924.0 1599.6 16324.4 0.6976 17923 1599	35.2	
100 0	17924.0 1599.6 16324.4 0.6976 17923 1599	35.2	
101 0	17924.0 1599.6 16324.4 0.6976 17923 1599	35.1	
102 0	17924.0 1599.6 16324.4 0.6976 17923 1599	35.1	
103 0	17924.0 1599.6 16324.4 0.6976 17923 1599	35.2	
104 0	17924.0 1599.6 16324.4 0.6976 17923 1599	35.1	
105 0	0.02316699.0***** -99.0000 2340 2316699	0.0	
106 0	0.02316699.0***** -99.0000 2340 2316699	0.0	
107 0	17924.0 1599.6 16324.4 0.6976 17923 1599	35.2	
108 0	12580.4 3393.1 9187.2 0.3926 13544 3393	15.3	
109 0	12580.4 3393.1 9187.2 0.3926 13544 3393	15.3	
110 0	18158.0 1833.6 16324.4 0.6976 17950 1833	22.8	
111 0	17924.0 1599.6 16324.4 0.6976 17923 1599	35.1	
112 0	17290.2 1464.3 15826.0 0.6763 17950 1464	38.2	

-----  
29-JUL-94 11:18:39 NRMII version 2.5.0 last changed 12 May, 1994

TERRAIN 1 FILE=crrelcko3.ter

20 UNITS, ID=Checkout terrain for CRREL winter effects model 22 J

SCENARIO 1 FILE=scenario.dat

"CRRELSNOW " ID=Dry,Snow,January (CRREL model)

VEHICLE 2 FILE=vehicles/hmmwv.crl

ID= HMMWV, M998, 4X4 FOR CRREL SNOW MODEL CHECKOUT 3 MAY 94

Snow model:CRREL

Weight [Lb]: 2@ 1625 + 2@ 2135 = 7520

NTU/	-----Gross-(soil only)-[Lb]-----	-----Total-[Lb]-	Speed
IBASE	Traction Resist. drawbar DB-Coeff. Tractn. Resist. [MPH]	TFmul1 MRmul1 T	
Snow depth=	0.0 in Density= 0.2 g/cm <sup>3</sup> Slope= 0.0 deg		
93 0	2051.1 286.1 1765.1 0.2347 2051 286	40.0	
94 0	2051.1 286.1 1765.1 0.2347 2051 286	40.0	
95 0	2051.1 286.1 1765.1 0.2347 2051 286	40.0	
96 0	5129.4 441.1 4688.3 0.6234 5129 441	40.0	
97 0	4520.6 576.5 3944.1 0.5245 4520 576	40.0	
98 0	5076.8 388.5 4688.3 0.6234 5076 388	40.0	
99 0	5076.8 388.5 4688.3 0.6234 5076 388	40.0	
100 0	5076.8 388.5 4688.3 0.6234 5076 388	40.0	
101 0	5129.4 441.1 4688.3 0.6234 5129 441	40.0	
102 0	5129.4 441.1 4688.3 0.6234 5129 441	40.0	
103 0	5076.8 388.5 4688.3 0.6234 5076 388	40.0	
104 0	5129.4 441.1 4688.3 0.6234 5129 441	40.0	
105 0	0.0 744480.0-744480.0 -99.0000 752 744480	0.0	
106 0	0.0 744480.0-744480.0 -99.0000 752 744480	0.0	
107 0	4332.6 388.5 3944.1 0.5245 4332 388	40.0	
108 0	2051.1 286.1 1765.1 0.2347 2051 286	40.0	
109 0	2051.1 286.1 1765.1 0.2347 2051 286	40.0	
110 0	4520.6 576.5 3944.1 0.5245 4520 576	40.0	
111 0	5129.4 441.1 4688.3 0.6234 5129 441	40.0	
112 0	5564.2 481.2 5083.0 0.6759 6053 481	40.0	

HMMWV  
Resistance

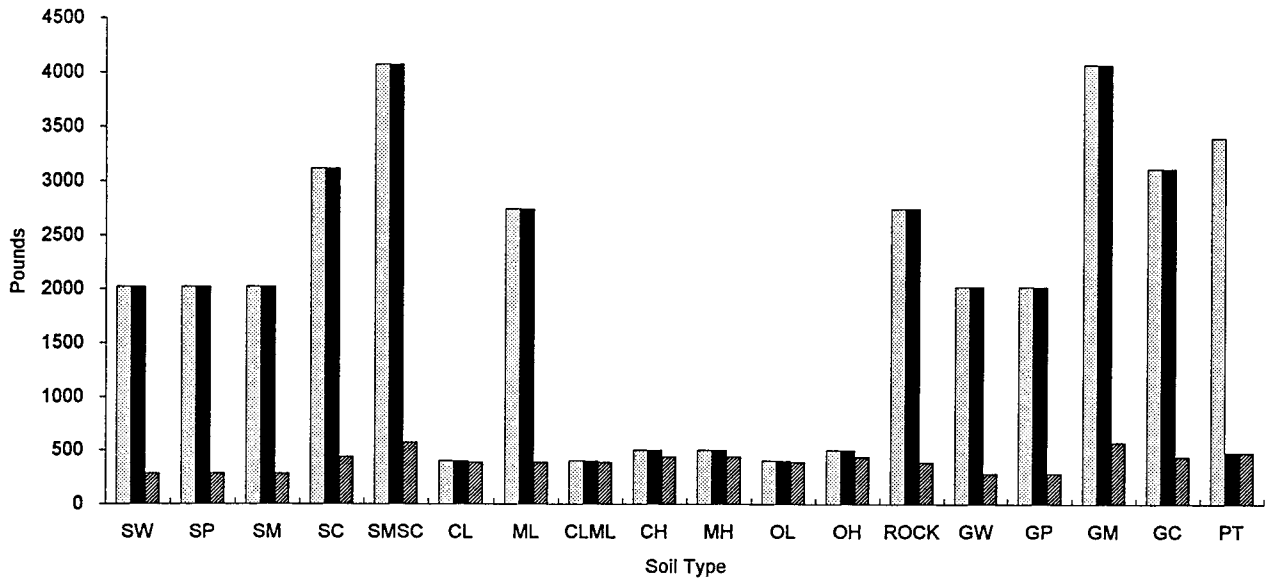

□ KWI=5; TMOIST=0% ■ KWI=0; TMOIST=40% ▨ normal

M113  
Resistance

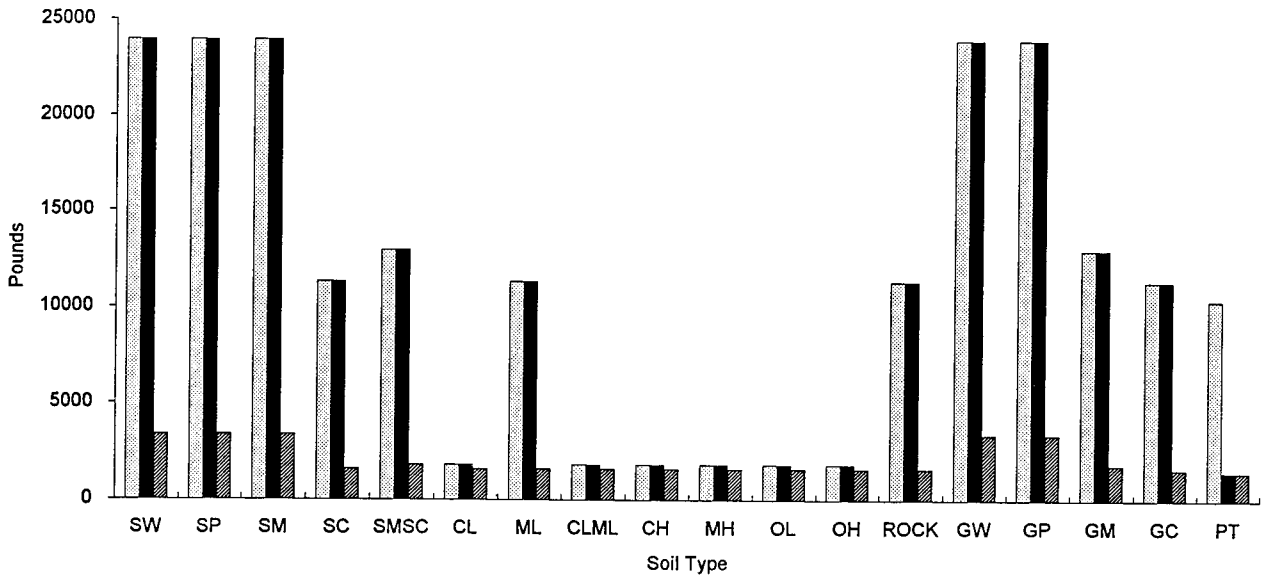

□ KWI=5; TMOIST=0% ■ KWI=0; TMOIST=40% ▨ Normal

HMMWV  
Traction

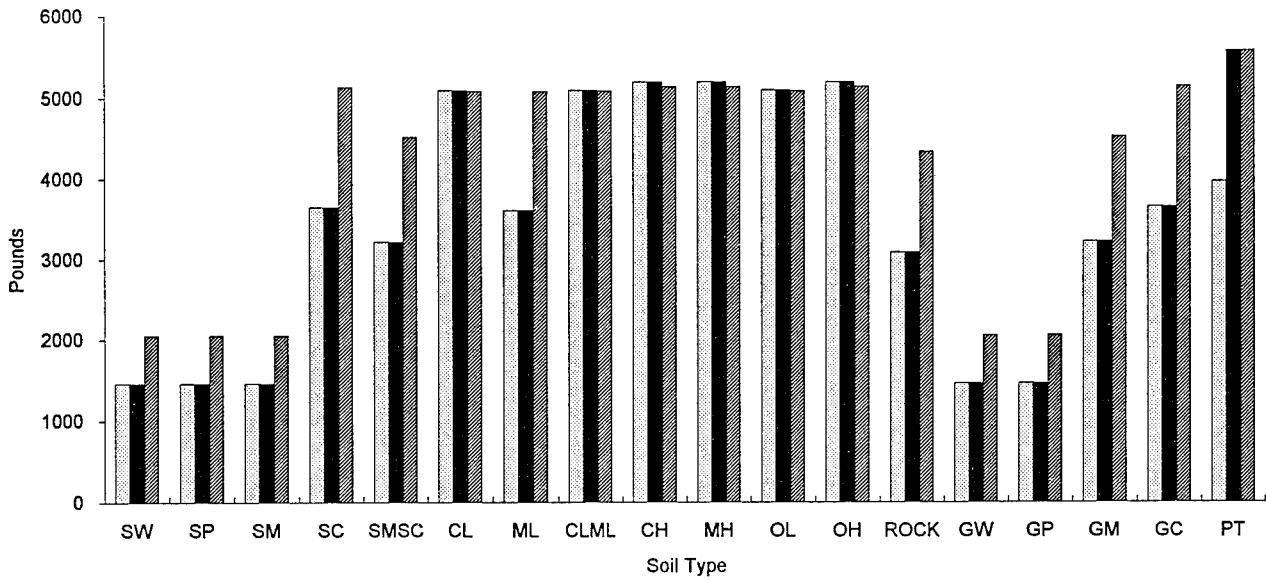

□ KWI=5; TMOIST=0% ■ KWI=0; TMOIST=40% ▨ Normal

M113  
Traction

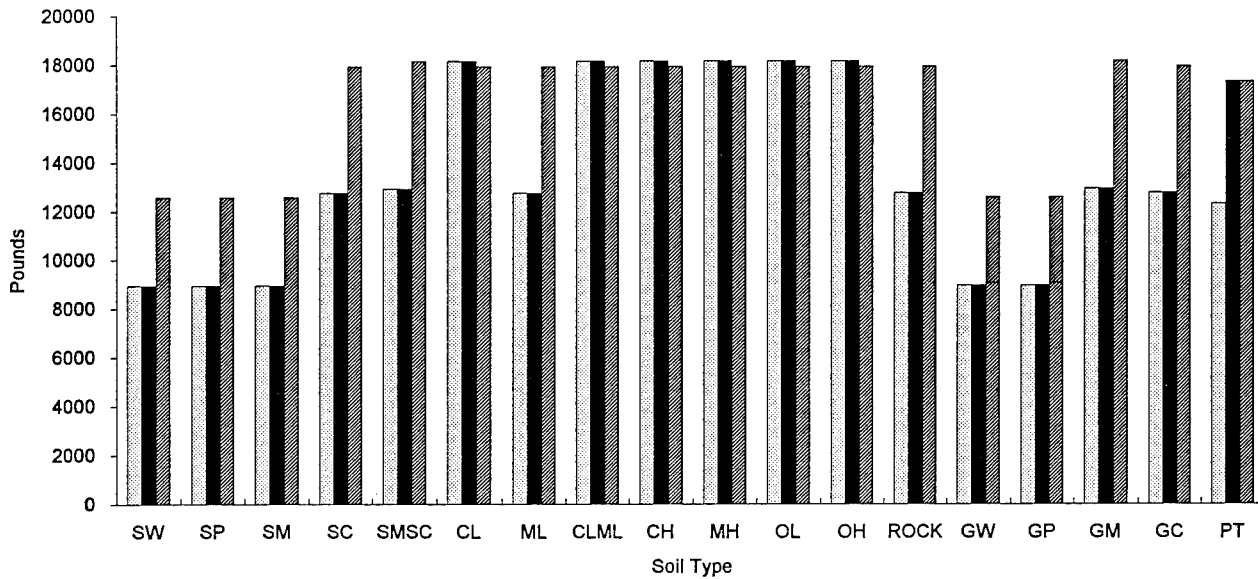

□ KWI=5; TMOIST=0%, TU46-65 ■ KWI=0; TMOIST=40%, TU66-85 ▨ Normal, TU93-112

