

PL-TR-94-2215

SPACE SYSTEMS ENVIRONMENTAL INTERACTION STUDIES

M. Alvin Morgan
Alan C. Huber
John O. McGarity
David J. Sperry
Scott J. Moran
John A. Pantazis

AMPTEK, INC.
6 De Angelo Drive
Bedford, Massachusetts 01730

30 August 1994

Scientific Report No. 3

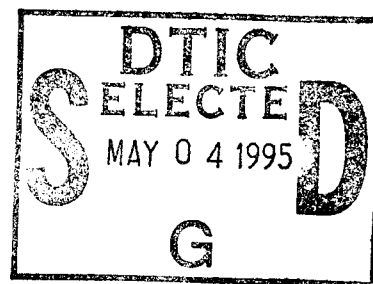

APPROVED FOR PUBLIC RELEASE; DISTRIBUTION UNLIMITED





PHILLIPS LABORATORY
Directorate of Geophysics
AIR FORCE MATERIEL COMMAND
HANSCOM AIR FORCE BASE, MA 01731-3010

19950503 145

ALL RIGHTS RESERVED

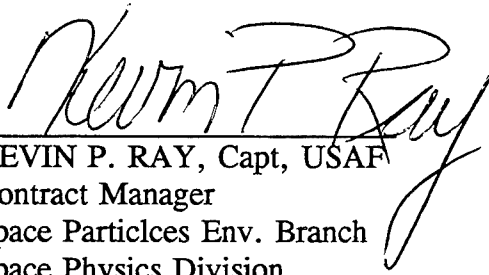
"This technical report has been reviewed and is approved for publication"

KEVIN P. RAY, Capt, USAF
Contract Manager
Space Particles Env. Branch
Space Physics Division

EDWARD G. MULLEN, Chief
Space Particles Env. Branch
Space Physics Division

WILLIAM SWIDER
Deputy Director
Space Physics Division

This report has been reviewed by the ESC Public Affairs Office (PA) and is releasable to the National Technical Information Service (NTIS).

Qualified requestors may obtain additional copies from the Defense Technical Information Center. All others should apply to the National Technical Information Service.

If your address has changed, or if you wish to be removed from the mailing list, or if the addressee is no longer employed by your organization, please notify PL/TSI, 29 Randolph Road, Hanscom AFB, MA 01731-3010. This will assist us in maintaining a current mailing list.

Do not return copies of this report unless contractual obligations or notices on a specific document requires that it be returned.

REPORT DOCUMENTATION PAGE

Form Approved
OMB No. 0704-0188

Public reporting burden for this collection of information is estimated to average 1 hour per response, including the time for reviewing instructions, searching existing data sources, gathering and maintaining the data needed, and completing and reviewing the collection of information. Send comments regarding this burden estimate or any other aspect of this collection of information, including suggestions for reducing this burden, to Washington Headquarters Services, Directorate for Information Operations and Reports, 1215 Jefferson Davis Highway, Suite 1204, Arlington, VA 22202-4302, and to the Office of Management and Budget, Paperwork Reduction Project (0704-0188), Washington, DC 20503.

1. AGENCY USE ONLY (Leave blank)	2. REPORT DATE 30 August 1994	3. REPORT TYPE AND DATES COVERED Scientific No. 3	
4. TITLE AND SUBTITLE Space Systems Environmental Interaction Studies		5. FUNDING NUMBERS PE: 63410F PR 2822 TA 01 WU AM Contract F19628-91-C-0112	
6. AUTHOR(S) M. Alvin Morgan David J. Sperry Alan C. Huber Scott J. Moran John O. McGarity John A. Pantazis			
7. PERFORMING ORGANIZATION NAME(S) AND ADDRESS(ES) AMPTEK, Inc. 6 De Angelo Drive Bedford, MA 01730		8. PERFORMING ORGANIZATION REPORT NUMBER	
9. SPONSORING / MONITORING AGENCY NAME(S) AND ADDRESS(ES) Phillips Laboratory 29 Randolph Road Hanscom AFB, MA 01731-3010 Contract Manager: Capt Kevin Ray /GPSG		10. SPONSORING / MONITORING AGENCY REPORT NUMBER PL-TR-94-2215	
11. SUPPLEMENTARY NOTES			
12a. DISTRIBUTION / AVAILABILITY STATEMENT Approved for public release; distribution unlimited.		12b. DISTRIBUTION CODE	
13. ABSTRACT (Maximum 200 words) The preparation of Ground Support Equipment (GSE) hardware and software, as well as, attending to launch support concerns prior to and after APEX launch, constitutes the extent of the effort expended on Task 1 (the Photovoltaic Array Space Power Plus Diagnostics [PASP Plus] experiment). Previously written test software was refined and new code generated, in order to accommodate real-time instrument performance monitoring during ground contact periods, and to facilitate the display of historical instrument performance data after a downlink opportunity. Under Task 2, the Charging Hazards and Wake Studies [CHAWS] program, Amptek, Inc. acted largely in a consultative and support role to PL/GPSG during this report period. Under Task 3 (the Space Wave Interactions with Plasmas Experiment [SWIPE]) GSE hardware was completed, and software was written and tested, for the electronics module of the EPI instrument on the OEDIPUS-C program. Two flight boxes are now in-house, fully assembled. Flight software for the constituent elements within the instrument was completed, and instrument functionality was fully exercised and checked. No additional change is envisaged to either hardware or software at this time.			
14. SUBJECT TERMS Photovoltaic Array Space Power Plus Diagnostics, PASP Plus, Charge Hazards and Wake Studies, CHAWS, Space Wave Interactions with Plasmas Experiment SWIPE			15. NUMBER OF PAGES 32
17. SECURITY CLASSIFICATION OF REPORT Unclassified			16. PRICE CODE
17. SECURITY CLASSIFICATION OF THIS PAGE Unclassified	18. SECURITY CLASSIFICATION OF THIS PAGE Unclassified	19. SECURITY CLASSIFICATION OF ABSTRACT Unclassified	20. LIMITATION OF ABSTRACT SAR

Table of Contents

Section	Page
1. Introduction	1
2. TASK #1 - PASP Plus Efforts	1
2.1 Summary of Activities	1
3. Ground Support Equipment (GSE) Hardware Description	3
3.1 SpiderBox Operation	3
3.2 Local Area Network Setup	3
4. GSE Real-Time Data Displays	4
4.1 SpiderBox Real-Time Display	4
4.2 Other Instrument Data Displays	5
4.2.1 I-V Curves <F1>	6
4.2.2 Housekeeping <F2>	7
4.2.3 Array Parameters <F3>	7
4.2.4 Langmuir Probe <F4>	9
4.2.5 ESA <F5>	9
4.2.6 TPM <F6>	10
4.2.7 Emitter <F7>	10
4.2.8 Array Temperatures <F8>	10
4.2.9 Raw Data <F10>	11
5. GSE Historical Data Displays	12
5.1 SpiderBox Data Display Screen	12
5.2 Instrument Displays	12
5.2.1 ESA/LP Screen <F4> Displays	12
5.2.2 ESA Screen <F5> Displays	13
5.2.3 Bias/TPM Screen <F6> Displays	14
5.2.4 Bias/LP/Leakage Current Screen <F7> Displays	16
6. TASK #2 - CHAWS Efforts	16
6.1 Summary of Activities	16
7. TASK #3 - OEDIPUS-C Efforts	17
7.1 Summary of Activities	17
7.2 EPI Measurements: Particle Spectra; Correlation & High Time Resolution	17
7.2.1 Background of OEDIPUS-C Instrument	17
7.2.2 EPI Electronics Module Functions	17
7.2.3 EPI Electronics Module CPU Interface	19
7.2.4 Data Format	20
7.2.4.1 Four Byte Label	20
7.2.4.2 Spectra Data	20

Table of Contents (Cont'd)

Section	Page
7.2.4.3 MMU Data	20
7.2.4.4 HFU Data	21
7.2.4.5 Overall Data Rate	21
7.3 EPI Software: Functionality & Code Overview	22
7.3.1 Software Program Overview for MMU	22
7.3.1.1 Interfaces	22
7.3.1.2 Reset & Power-up Initialization	22
7.3.1.3 INT1: o/p request from CPU	22
7.3.1.4 INT0: next PRF	23
7.3.1.5 OUTPUT	23
7.3.2 Software Pseudo-Program for CPU	24
7.3.2.1 Interfaces	24
7.3.2.2 Reset & Power-up	24
7.3.2.3 Interupts	25

List of Figures

Number	Page
1: PASP Plus GSE Data Display Network	2
2: Spiderbox Real-Time GSE Display	4
3: Real-Time I-V Curve Display	5
4: Real-Time Housekeeping Display	6
5: Real-Time Array Parameters Display	7
6: Real-Time Langmuir Probe (LP) & ElectroStatic Analyzer (ESA) Display	8
7: Real-Time Transient Pulse Monitor (TPM) Display	8
8: Real-Time Emitter & ESA Monitor Voltage Display	9
9: Real-Time Array Temperatures Display	10
10: Real-Time GSE Raw Data Display	11
11: Spiderbox Database Display Screen	11
12: Historical ESA/LP Data Display	12
13: Historical ESA/LP Zoomed-out Data Display	13
14: Historical ESA Electron-Ion Data Display	14
15: Historical Array Bias/LP/TPM Data Display	15
16: Historical Array Bias/LP/Leakage Current Data Display	15
17: Interface Board Schematic.....	18
18: High Frequency Buncher Board Schematic	19
19: Micro Controller Board Schematic	20
20: Central Processor Board Schematic	21

Accession For	
NTIS CRA&I	<input checked="" type="checkbox"/>
DTIC TAB	<input type="checkbox"/>
Unannounced	<input type="checkbox"/>
Justification	
By	
Distribution /	
Availability Codes	
Dist	Avail and/or Special
A-1	

1.0 INTRODUCTION

This is the third interim scientific report for Contract #F19628-91-C-0112, whose objective is to investigate spacecraft-environment interaction and space-plasma dynamics issues, especially as they relate to differential charging, discharge mechanisms, coupling between plasmas and space power systems, wake formation mechanisms, EM wave-particle interactions, and long-term radiation effects on operating systems in space.

The work is to be accomplished in three distinct *in-situ* investigatory programs (identified as Task #'s (1), (2) and (3) and the completion of a data analysis and presentation period. Significant efforts were expended on Task #1 and Task #3 during the report period, with somewhat less being carried out on Task #2. Those efforts are detailed here. The material is presented in serial order, with issues relating to Task #1 discussed first in Section 2.

2.0 TASK #1—PASP Plus EFFORTS

2.1 Summary of Activities

The preparation of Ground Support Equipment (GSE) hardware and software, as well as, attending to launch support concerns prior to and after APEX launch, constitutes the extent of PASP Plus efforts during the report period.

A Local Area Network (LAN) of four IBM type PCs—one of which (referred to as the *spiderbox*) acts as a server for the others—was assembled to strip out the PASP Plus data from the APEX downlink and distribute it for viewing on the LAN PCs. Amptek, Inc. designed and built the hardware that does the actual data extraction. It is in the form of a printed circuit board card, which fits into a slot inside the spiderbox. The spiderbox PC, the LAN software, as well as the hardware necessary to implement the LAN, were all procured by Amptek, Inc. The other PCs were supplied as Government Furnished Equipment (GFE), by PL/GPSG. Additional details on the spiderbox hardware and on the LAN setup are presented in the following Sections 3.1 and 3.2.

Much effort was spent on refining previously written software and generating new code, in order to accommodate instrument data displays on the GSE. Software was written for two purposes. The initial task was to support instrument and system integration testing of the component elements within the PASP Plus payload. The initial version of the code therefore facilitated real-time commanding of the various instruments and provided an immediate indication of a unit's status and output. After making some changes to this software, it is now possible to view the same information on the LAN, during the real-time ground contact periods for APEX. An abridged description of the functionality of this code and its principal diagnostic display screen were reported on earlier in Scientific Report No. 1. A full description will now be provided in Section 4, in which the GSE Real time Data Displays will be discussed and a view of each of the instrument display screens presented. In the case of the overall payload housekeeping data display, for which the version appearing on the spiderbox is somewhat more comprehensive in its parameter list than that shown on the other LAN PC displays, the differences between the two will be explained.

The other set of software was written to facilitate the display of historical instrument performance data. i.e the data which was acquired when the spacecraft was not in contact with the ground. As there are nominally only four to five real-time contacts per day, the GSE's historical data displays allows for an over-all look at the recorded data, which, since the real-time acquisitions are also recorded in the

historical data file, is the entire PASP Plus data set. Details on the various display screens generated in this software version follows in Section 5.

Immediately following the successful insertion of APEX into orbit (which occurred near the end of this report period), PASP Plus instruments—starting with the Controller—were turned ON, as soon as the spacecraft had acquired the sun and was stabilized. To date, all indicators point to near nominal functionality for the entire payload. It has been necessary however, to make some minor corrections to the GSE software, in order either to improve some data displays, or to add additional functionality to others. Indeed this task is somewhat open ended, for PASP Plus is as an active experiment as far as its Solar Array biasing and Emitter operations segments are concerned. New Array bias levels and Emitter ON times are set in response to the data acquired from previous settings and further requests from PL/GPSG to additionally enhance particular features of an existing display, or to generate new ones, are therefore anticipated, as instrument performance data comes in from interactions over the entire range of environmental conditions.

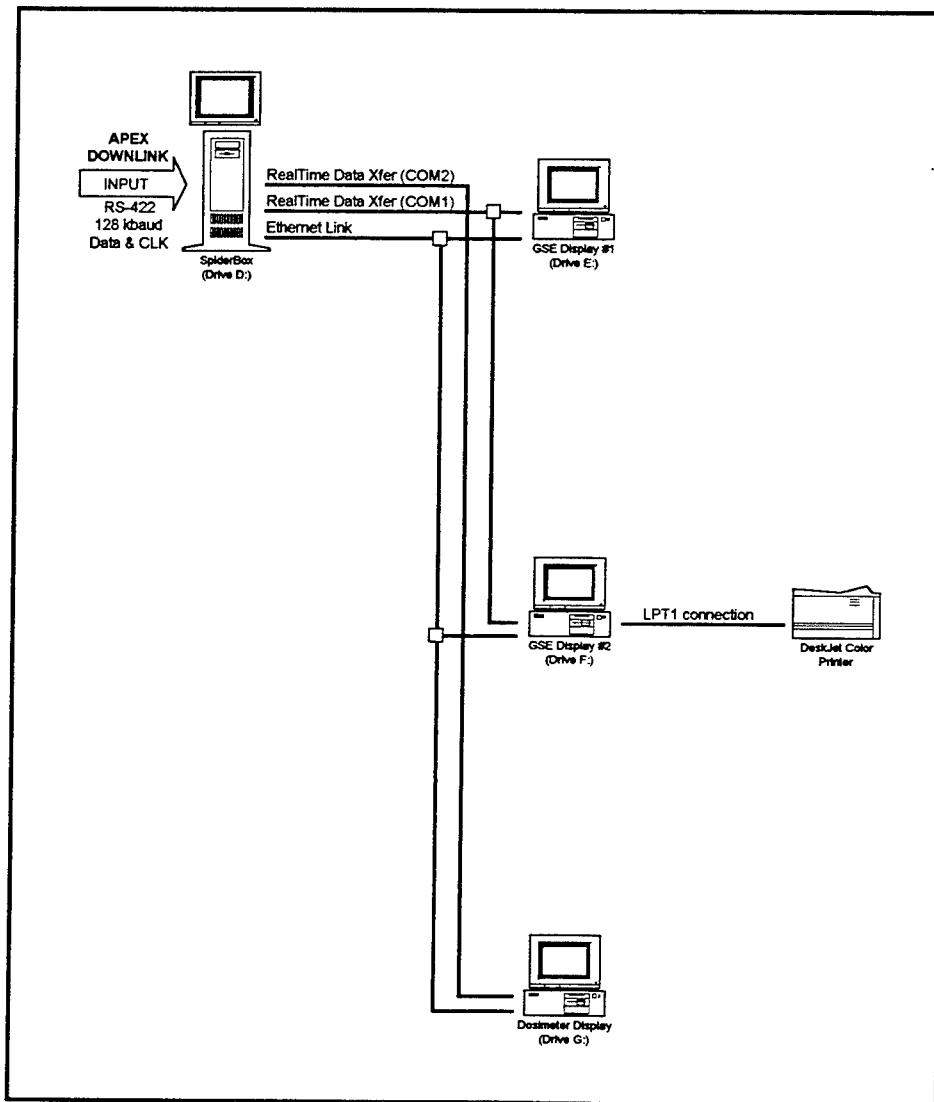

FIGURE 1: PASP PLUS GSE DATA DISPLAY NETWORK

3.0 GROUND SUPPORT EQUIPMENT (GSE) HARDWARE DESCRIPTION

3.1 SpiderBox Operation

APEX Telemetry and a clock signal are serially fed into the spiderbox via a RS-422 synchronous link. Immediately after the clock signal is detected, on-going activities on the spiderbox are interrupted and the hardware goes into an acceptance mode for telemetered data. The nominal 128 kbaud input or the contingency mode's 64 kbaud feed (the Spiderbox software will automatically handle either one) is examined for an identifying 4-byte synch word at the beginning of each telemetry minor frame. When this has been accomplished the contents in the frames containing PASP Plus data is retrieved and essential housekeeping information is displayed on the SpiderBox display screen. Additional material is made available to a PASP Plus GSE display which shows radiation dosage information only, and to two other GSE displays on which various other instrument parameters might be observed. At the end of a downlink period, all of the telemetered data is saved in a *pass file* on the spiderbox.

3.2 Local Area Network Setup

The GSE hardware setup is shown in Figure 1. As can be seen, it is comprised of four Personal Computers (PCs)—which are Government Furnished Equipment (GFE)—interfaced together via an Ethernet link, in a Local Area Network (LAN). This arrangement facilitates the speedy transfer of large files, from one machine to any other, for as is indicated in Figure 1, each PC appears as a unique disk drive to another. In fact, a data file resident on one machine could be accessed and utilized by another, without having to transfer a copy of the file over to the executing PC. This flexibility allows for a minimum of file copies to be resident on the network, yet accommodates independent functionality of each PC when necessary.

Printing from each PC is also facilitated to a color DeskJet printer, which is connected to GSE Display #2. The *PRINT SCREEN* keyboard feature is enabled in the GSE software, so that screen displays may be captured on hardcopy when desired. One PC—the spiderbox—acts as the server to the other units, and as previously mentioned, it is a 486/66 IBM type machine within which the custom built telemetry interface PCB resides. The other three machines are 386/25 IBM type PCs.

In addition to the Ethernet link, there are two serial connections from the SpiderBox to the other PCs on the LAN. One of these—COM2—is connected to the serial port on the Dosimeter GSE PC and it is the pathway for real-time Dosimeter data transfer, after it is stripped out of the APEX downlink. COM1 on the other hand, is connected in parallel to the serial ports of both GSE #1 and GSE #2. The real-time PASP Plus data is transferred on this link to those two PCs, which can in turn, display that information if it is so desired.

At the end of an APEX downlink opportunity, historical data is extracted from both the relevant PASP Plus and Dosimeter data frames in the telemetry and a historical data file is generated for each. The material is then automatically copied to the respective hard disks on the LAN from which it may be scrutinized with the aid of the historical display screens.

4.0 GSE REAL-TIME DATA DISPLAYS

4.1 SpiderBox Real-Time Display

The GSE display software ended up as a fairly complex and comprehensive package, which allows a great deal of ease and flexibility in viewing both real-time and historical downlinked data. The real-time housekeeping display which appears by default on the spiderbox, is shown in Figure 2. It is an enhanced version of the basic housekeeping display, which has been in place on the test GSE for some time now, and which is seen on GSE #1 and GSE #2.

During those portions of it's orbit when APEX is in contact with the ground, essential PASP Plus instrument performance information is displayed on the spiderbox monitor in real-time. Voltage monitors for the +28V bus to the Controller and for each of the internally derived voltages are displayed in section (A). Also appearing here is the temperature of each payload unit, and of each Solar Array module which has a built-in temperature sensor. Some additional Controller calibration information (RTD Reference, A/D offset and 0° RTD Temp) are also shown here, as are the two QCM output frequencies, the PASP Plus Sun Sensor angles, the payload related temperatures which are monitored by the spacecraft, and the spacecraft's Sun Sensor output. The last two items appear among the lighter shaded entries in Figure 2 as a consequence of the fact that these parameters appear in a different color from the other entries on a color monitor, in order to easily identify them as originating from APEX and not PASP Plus system monitors. The information is stripped out of the APEX housekeeping telemetry block in the satellite downlink, and displayed with the PASP Plus derived data. The temperatures shown are those for the Deployed Panel, the Payload Shelf, the external box temperatures of the Controller, the Dosimeter and two E-Field Sensors, as well as, the APEX Sun Sensor angles.

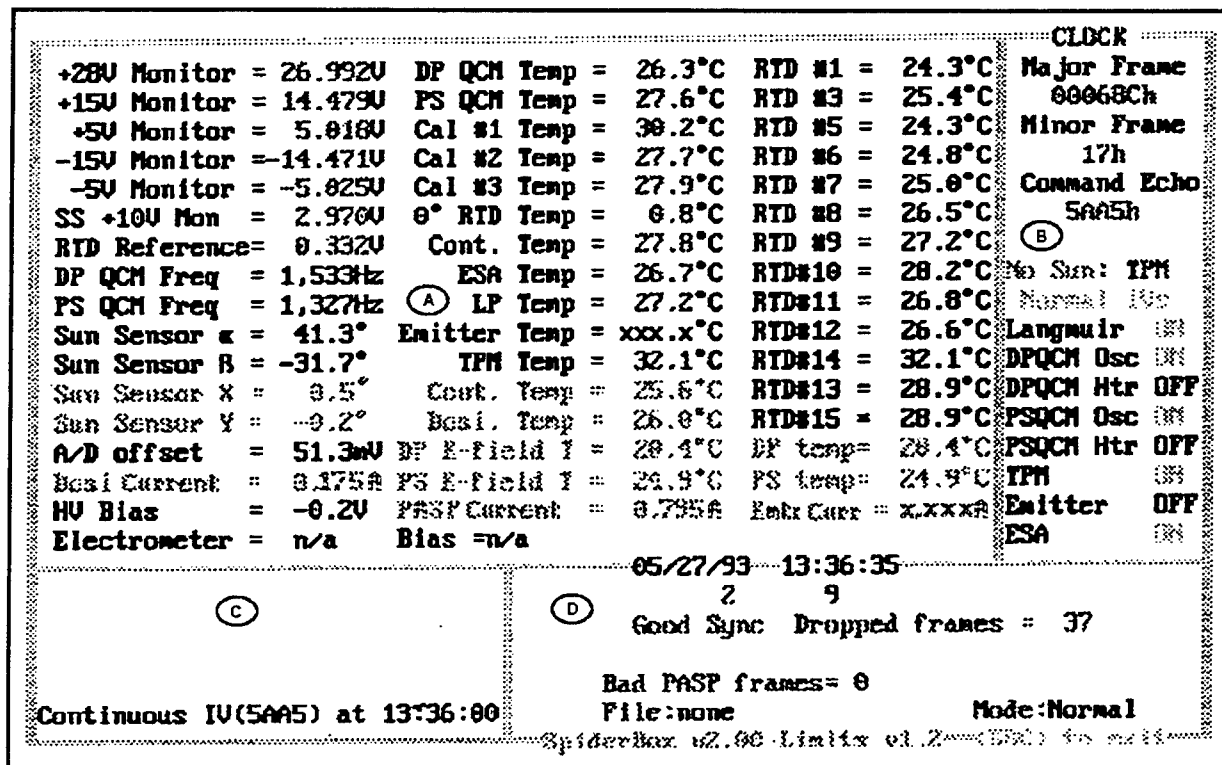

FIGURE 2: SPIDERBOX REAL-TIME GSE DISPLAY

A final inclusion in this display block are the +28V bus current for the three separate feeds to the PASP Plus payloads, i.e to the Dosimeter, the Controller and the Emitter, which are also APEX housekeeping originated data that is extracted from the downlinked telemetry for display here. This display of APEX housekeeping information is the only difference between the real-time display screen on the spiderbox and that appearing on GSE #1 and GSE #2. APEX acquired data is only shown on the former.

The information displayed in section (B) and in section (C) is identical for all GSE displays. As can be seen, ON/OFF status indicators for each of the instruments in the PASP Plus payload are displayed in section (B). An indication of whether or not the sun is in view of the PASP Plus Sun Sensor, the TPM is powered and the type of the IV sampling being carried out on the array modules are also located here. At the top of the block is an indication of whether or not the telemetry clock input is running and the major and minor PASP Plus telemetry frame counters. section (C) is a Command Echo block. All commands received at the Controller are displayed here, in the order received. Information which is relevant to the state of the telemetry feed is displayed in section (D). This block is unique to the Spiderbox and included in it are indications of the state of the received telemetry frames, the telemetry mode and the file to which data is being written.

4.2 Other Instrument Data Displays

Of the four display blocks shown in Figure 2, the particular parameters which appear in sections (B) and (C) remains unchanged. Different information may be displayed in section (A) and in section (D) however, by depressing any one of eleven function keys on the GSE #1 or GSE #2 keyboards. The specific data screen which might be so obtained, its corresponding function key and a description of the display follows.

4.2.1 I-V Curves <F1> Display

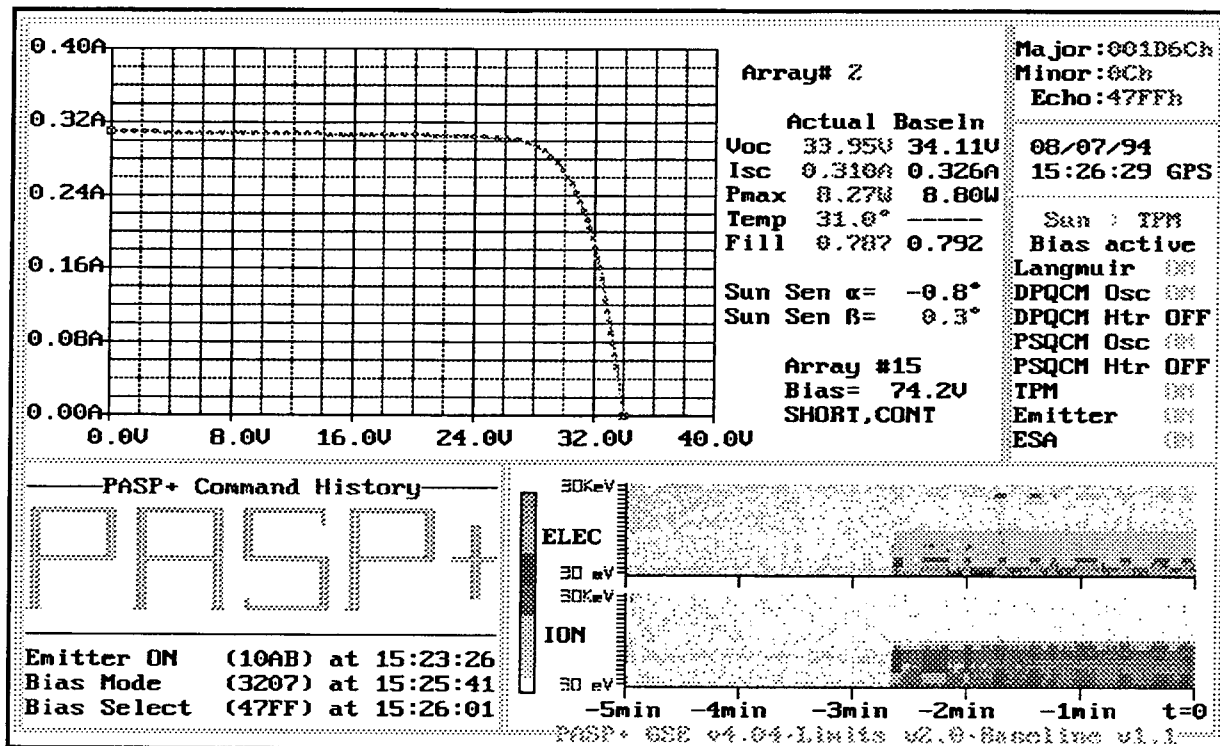

FIGURE 3: REAL-TIME I-V CURVE DISPLAY

The real-time GSE I-V curve display is shown in section (A) of Figure 3. It is obtained by selecting the F1 key on the keyboard. The I-V characteristic of each array module is sequentially sampled every two minutes by the PASP Plus Controller and the latest such curve is the default display (it is denoted by the word *(Auto)* next to the array number at the top of the screen) for this block. Any of the sixteen array module I-V curves may be selected for viewing however, by depressing either the plus (+) or minus (-) keys on the keyboard. This action allows the viewer to scroll through all sixteen I-V's in an incrementing or decrementing fashion.

In addition to the I-V curve, key parameters of the characteristic are also shown. These are: the open circuit voltage (Voc); short circuit current (Isc); maximum power (Pmax); array temperature and fill factor. A set of baseline numbers obtained from ground testing under simulated full sun conditions, are shown in the adjacent column for comparison purposes. It is noted too, that the payload's Sun Sensor angles appear here in this display block, as is, when biasing is being carried out an array, the biased array number, the immediate bias step voltage and the biasing conditions.

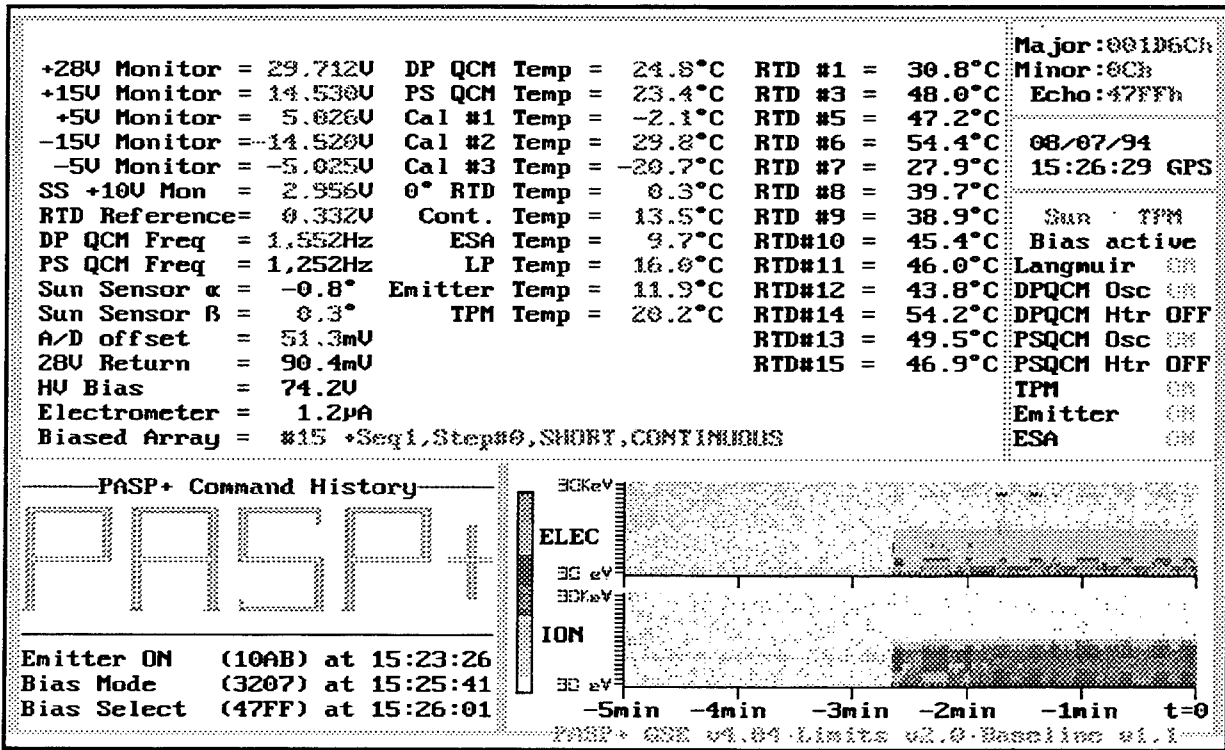

FIGURE 4: REAL-TIME HOUSEKEEPING DISPLAY

4.2.2 Housekeeping <F2> Display

The real-time GSE housekeeping display is shown in section (A) of Figure 4. It is obtained by selecting the F2 key on the keyboard. The information displayed here is almost identical to that shown in Figure 2, for the spiderbox display. The key difference is that the APEX acquired data which is stripped out of the APEX housekeeping telemetry and displayed on the spider-box, does not appear here.

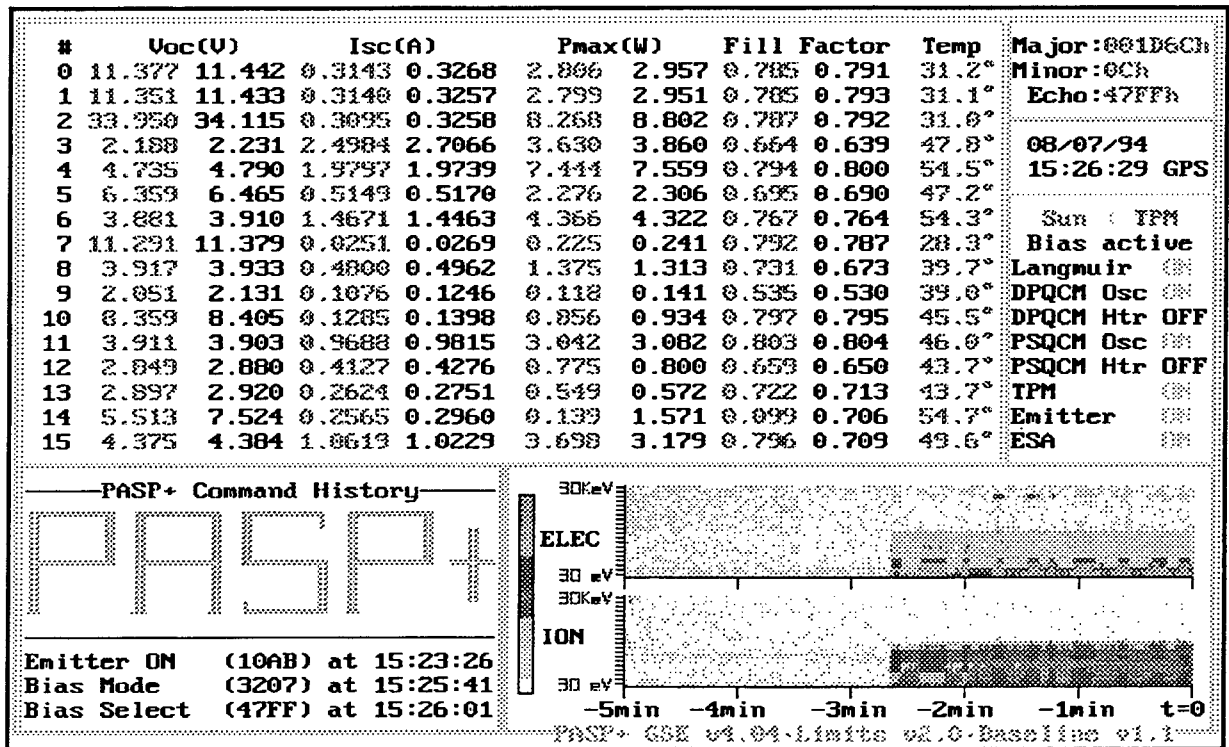

FIGURE 5: REAL-TIME ARRAY PARAMETERS DISPLAY

4.2.3 Array Parameters <F3> Display

The real-time GSE Array Parameters display is shown in section (A) of Figure 5. It is obtained by selecting the F3 key on the keyboard. Displayed here are the key array I-V curve parameters which appear in Figure 3, for all of the Array modules. Two sets of numbers appear in the entries under each column heading. The number on the left is the measured value and it is color coded to reflect whether or not it is nominal (green), marginal (yellow) or outside the expected limits (red). The number on the right is a reference value, which was obtained from ground testing under simulated full sun conditions.

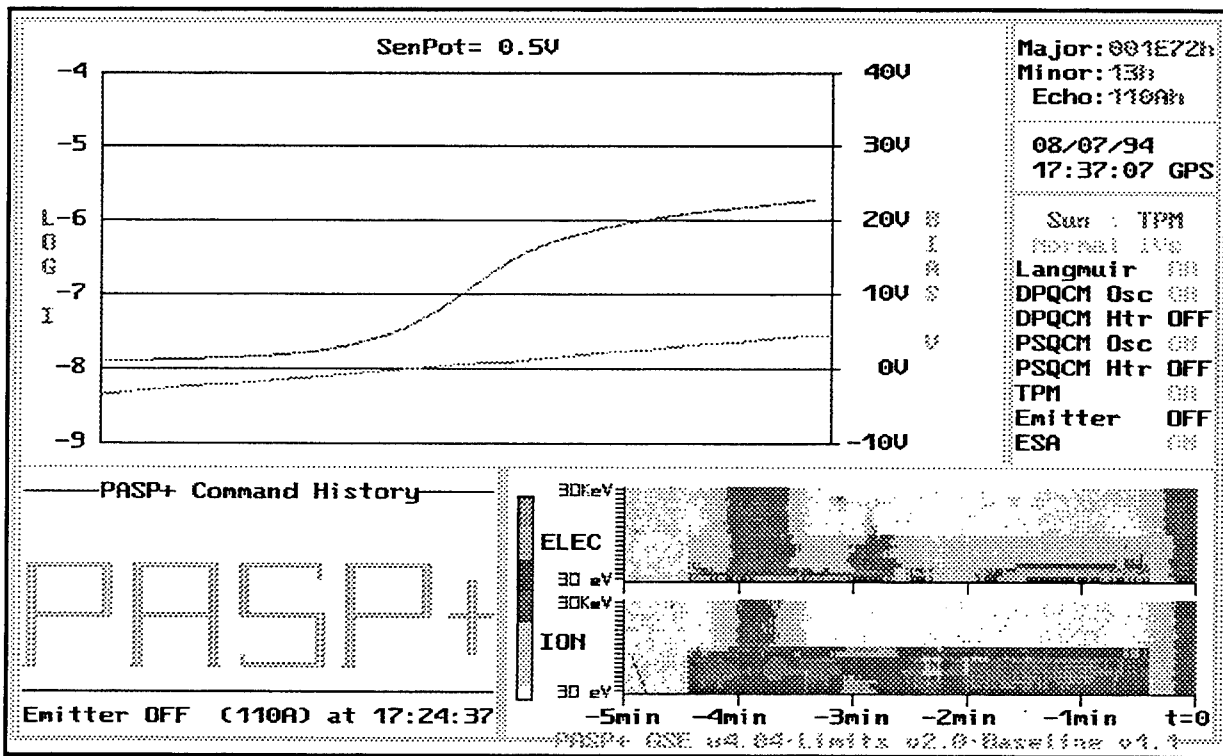

FIGURE 6: REAL-TIME LANGMUIR PROBE (LP) & ELECTROSTATIC ANALYZER (ESA) DISPLAYS

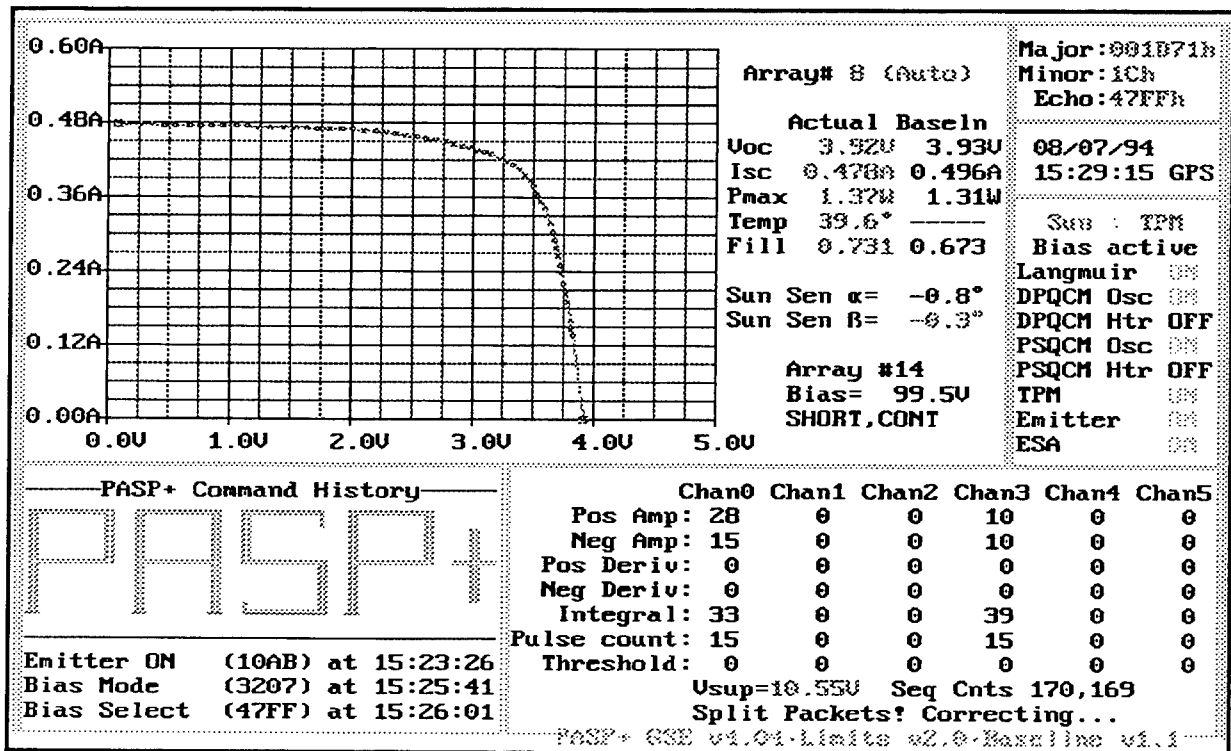

FIGURE 7: REAL-TIME TRANSIENT PULSE MONITOR (TPM) DISPLAY

4.2.4 Langmuir Probe <F4> Display

The real-time GSE Langmuir Probe display is shown in section (A) of Figure 6. It is obtained by selecting the F4 key on the keyboard. The information displayed here are: (i) the instrument's Ne current output plotted with the logarithmic y-axis scale on the left, and (ii) the BIASMON voltage output which is plotted with the linear y-axis scale on the right. The x-axis spans a period of one second. The instrument has within it some electronic circuitry which senses the spacecraft's potential and compensates for it, in its operation. This sensing potential (Senpot) value is shown in the middle top of the display.

4.2.5 ESA <F5> Display

The real-time GSE ElectroStatic Analyzer (ESA) display is shown in section (C) of Figure 6. It is obtained by selecting the F5 key on the keyboard. Shown here is a color coded display of the output of each of the twenty energy channels, for both ions and electrons, in the instrument. The last five minutes worth of data may be observed, after which the display scrolls over. A color legend for this display block is not shown, but it is identical to that for the historical ESA data display which is forthcoming. Additional instrument diagnostic information for the ESA can be obtained with the F7 key. As will be seen shortly, voltage monitor data for both the high voltage applied to deflection plates and the low voltage used to power electronic components, are displayed here.

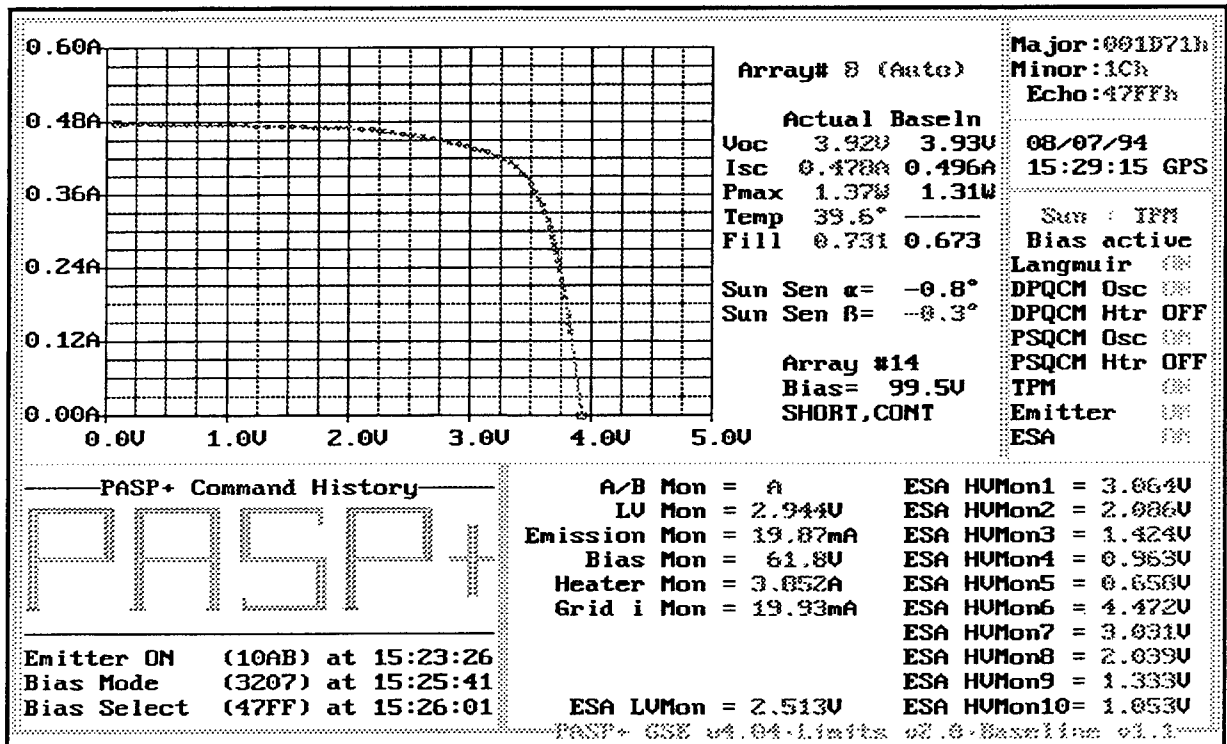

FIGURE 8: REAL-TIME EMITTER & ESA MONITOR VOLTAGE DISPLAYS

4.2.6 TPM <F6> Display

The real-time GSE Transient Pulse Monitor (TPM) display is shown in section ① of Figure 7. It is obtained by selecting the F6 key on the keyboard. This is the principal diagnostic instrument for arcing on the array modules, in response to an applied bias voltage, and its digital output is decoded and the arc characterizing data for each of its six channels is displayed here.

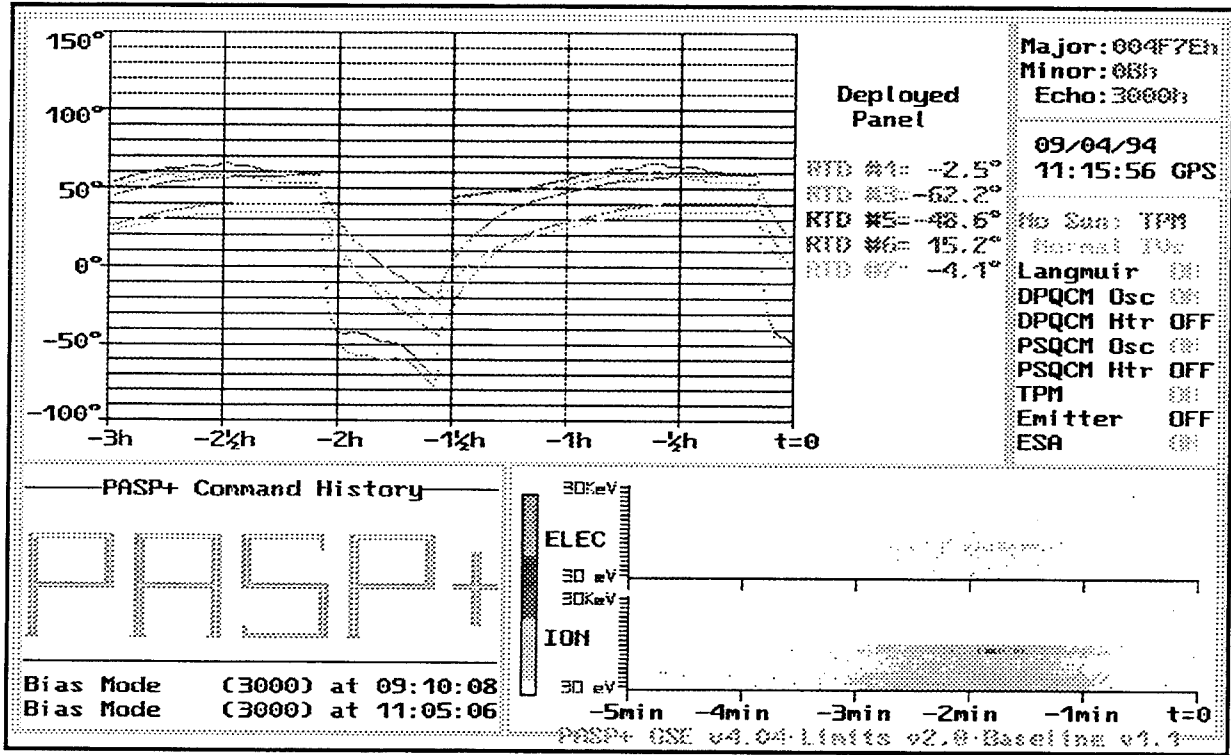

FIGURE 9: REAL-TIME ARRAY TEMPERATURES DISPLAY

4.2.7 Emitter <F7> Display

The real-time GSE Emitter display is shown in section ② of Figure 8. It is obtained by selecting the F7 key on the keyboard. The first six entries in this display block provide diagnostic information about the state of the instrument and its performance. The other entries are performance data for the ESA.

4.2.8 Array Temperatures <F8> Display

The real-time GSE array temperature display is shown in section ③ of Figure 9. It is obtained by selecting the F8 key on the keyboard. The temperature of each array module with a built-in temperature sensor or RTD on the Deployed Panel, is shown in a distinguishing color on this screen for a time period of up to three hours. This function key toggles, so that by pressing it a second time the temperature for the modules on the Payload Shelf can be observed.

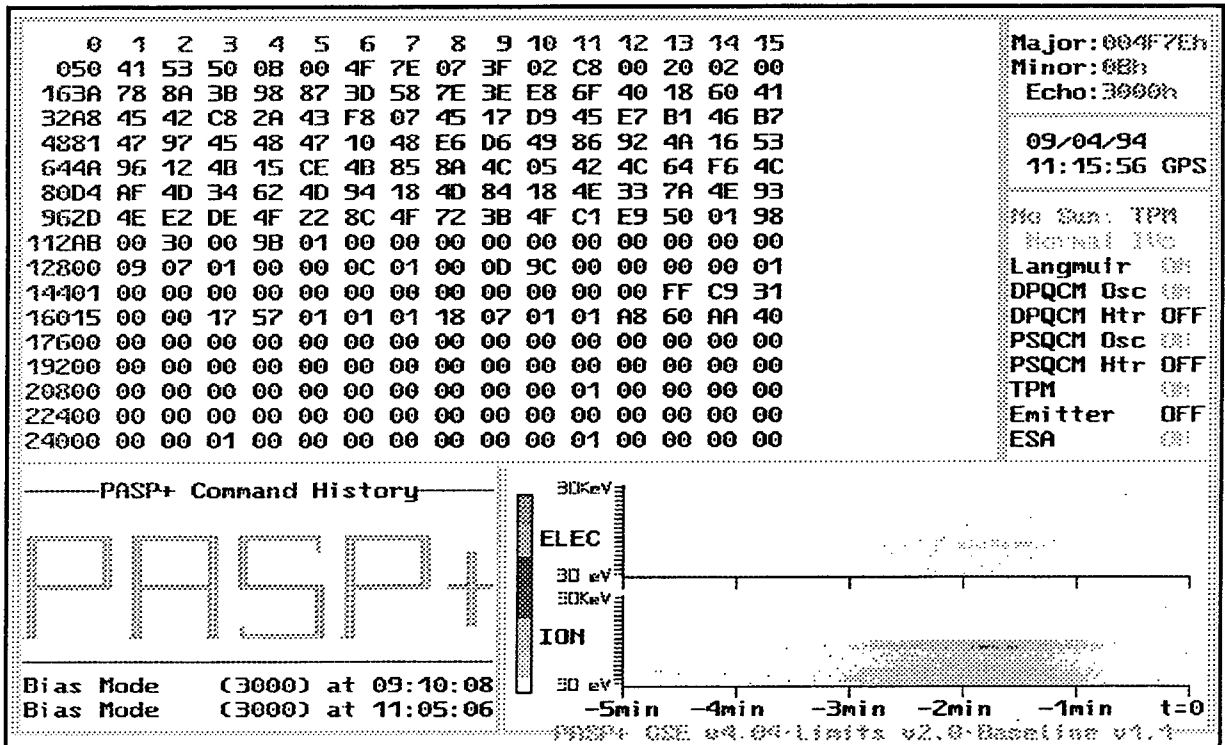

FIGURE 10: REAL-TIME RAW DATA DISPLAY

4.2.9 Raw Data <F10> Display

The real-time raw data display is shown in section (A) of Figure 10. It is obtained by selecting the F10 key on the keyboard. The 256 bytes returned by the Controller each second can be seen in this display, in hexadecimal format. It is this data that is decommed and shown in all of the other displays and it is sometimes useful, to revert back to this comprehensive source to observe particular aspects of the data, to compare changes in specific byte blocks that are not otherwise observable, or even to double-check the authenticity of the data elsewhere.

PASP+ Data Files				-Power-		B					
Filename	----START----		----END----		L	E	T	I	H	C.	# of
	Date	Time	Date	Time	P	M	A	S	R	V	
24hr.dat	05/27/93	00:00:00	05/27/93	11:59:59	X	X	X	X			24
test2.dat	01/06/93	00:00:00	01/06/93	02:36:14	X	X	X	X	X		157
pasp10.dat	05/28/93	00:00:00	05/28/93	11:59:59	X	X	X	X		X	29

↑ ↓ Enter/ESC

FIGURE 11: SPIDERBOX DATABASE DISPLAY SCREEN

5.0 GSE HISTORICAL DATA DISPLAYS

5.1 Spiderbox Database Display Screen

Figure 11 shows the default Spiderbox screen at the end of a satellite contact period. It is essentially a file allocation table with PASP Plus data file entries which were created from each contact download. The data filename, as well as, the beginning and end period over which the data was acquired on-orbit are the first items displayed. An indication of whether or not any of the five payload units which can be turned ON/OFF by ground command—i.e. the Langmuir Probe (LP), Emitter (EM) Transient Pulse Monitor (TPM) and the ElectroStatic Analyzer (ESA)—was turned ON within a file, is also shown, in addition to whether or not array biasing (BIAS), arcing (HVR), or continuous I-V (CIV) sampling, occurred. The final entry shows the number of commands executed by the Controller during the duration of the file.

Immediately after the Spiderbox screen display reverts to the default shown in Figure 11, it transfers a copy of the latest data file to the root directory of each PC connected to the LAN. The GSE program *PASPOF.EXE* which is installed on the network, can then be used to look at specific features of the data in this or any other file in the spiderbox database.

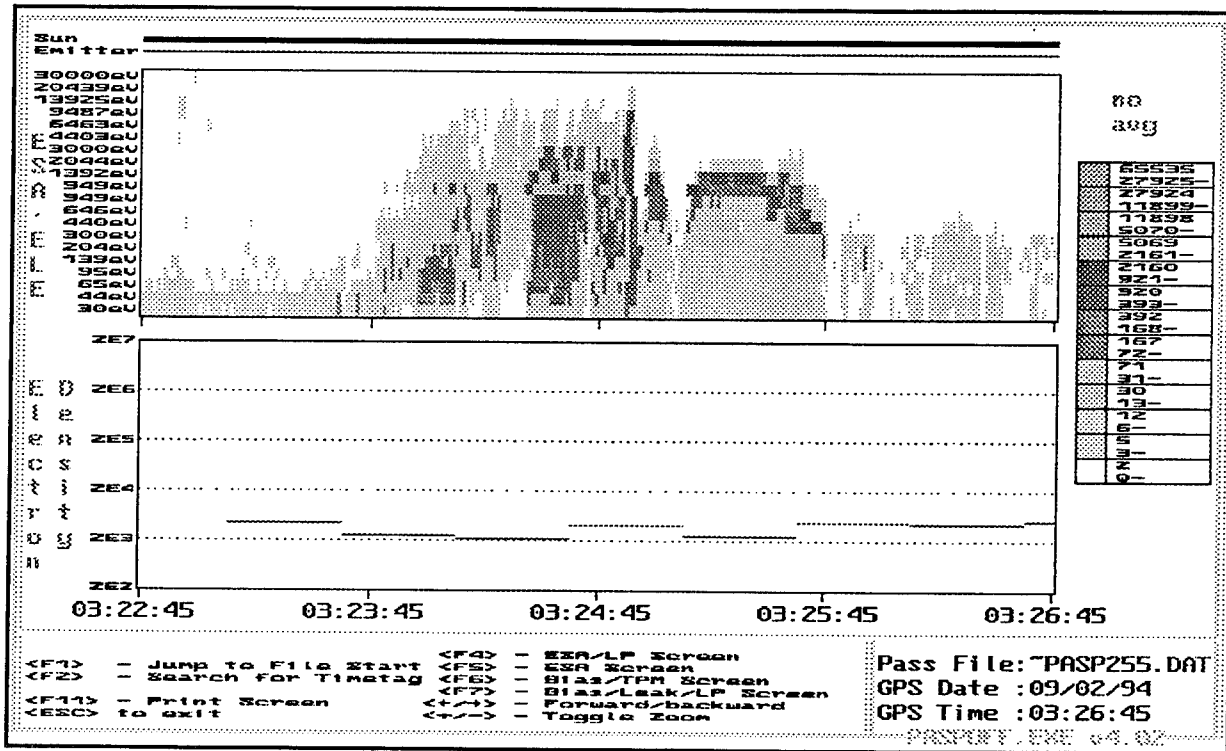

FIGURE 12: HISTORICAL ESA/LP DEFAULT DATA DISPLAY

5.2 Instrument Data Displays

5.2.1 ESA/LP Screen <F4> Display

An illustration of the ESA Electrons/LP Electron Density display screen showing on-orbit data is presented in Figure 12. On selecting the ESA/LP Screen <F4> for display, the program automatically looks through the file for the first occurrence of ESA and LP data and displays the initial four minutes

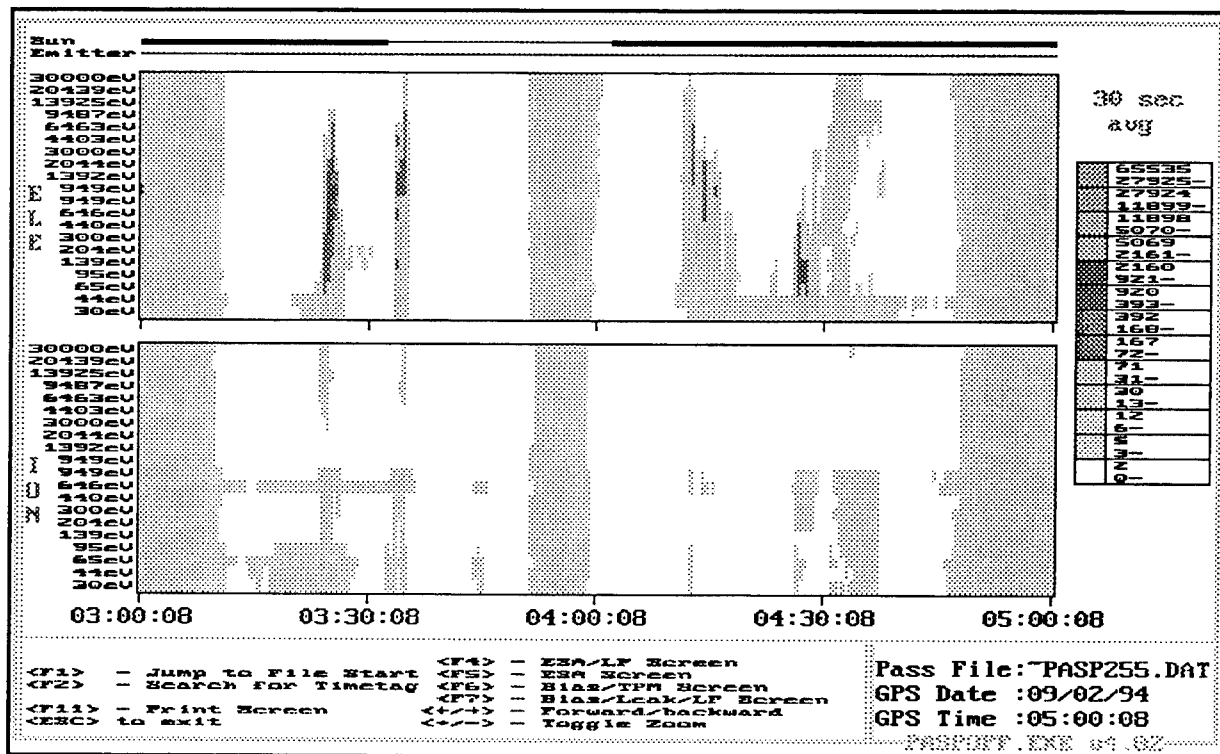

FIGURE 14: HISTORICAL ESA ELECTRON-ION DATA DISPLAY

5.2.3 Bias/TPM Screen <F6> Display

The Array Bias/LP/TPM display is shown in Figure 15. It shows at a glance the biasing particulars on the solar array modules, and the TPM's response to that activity. The module number to which bias voltage is applied, as well as the magnitude and duration of the bias, are shown in the display panel at the top of the screen. Both positive and negative voltage steps are accommodated for values between -500V to +500V. Any discontinuity in the biasing profile will be displayed, including those resulting from high voltage resets due to arcing, or APEX late polling timeouts. It is possible to distinguish on a color monitor, which of these events occurred and when it happened. Although it is difficult to see in Figure 15, the electron density—as determined from the Langmuir Probe's Ne output—is also overlaid on this display. The y-axis scale on the left hand side of the screen gives is used to determine the actual number density.

Data on a specific array module can be called up for display by selecting <F3> on the keyboard. In this instance, only data for the chosen array will be shown. The default display—as is seen in Figure 15—is to display the first available modules that fit within the x-axis timeframe.

The TPM output appears in the panel immediately below that for the array Bias and Langmuir Probe, in the bottom half of the screen. It is a compact display which shows the three principal TPM output parameters at a glance. A count of the number of events recorded for each of the five E field sensor channel (CNT 0..5) is shown in the top half of the panel, and the peak amplitude for both positive and negative discharges (AMP 0..5) in each channel, is shown in the lower half. A color legend for both counts and amplitude is shown to the right of the panel and although it is not apparent in Figure 15, negative and positive amplitudes of the same magnitude are differentiated in color, by a specific fill pattern.

5.2.4 Bias/LP/Leakage Current Screen <F7> Display

The final historical data display screen is the array Bias/LP/Leakage/Emitter Grid Current display shown in Figure 16. It is obtained by selecting the F7 function key. The display reflects the need to see at a glance, all of the key parameters necessary to make bias step determination decisions, when real-time array biasing is underway. Hence, the Bias Step information superimposed with the LP electron density data from Figure 15, is replicated in the top panel of the display panel. In the bottom panel, leakage current is superimposed on emitter grid current for the display. Leakage Current is most meaningful when an array module is being positively biased, and the Emitter Grid Current is necessarily only present when the Emitter is powered ON.

6.0 TASK #2—CHAWS EFFORTS

6.1 Summary of Activities

Amptek, Inc. acted largely in a consultative and support role to PL/GPSG during this report period. In particular, our input was sought on the potential causes of anomalous behavior observed on orbit, during operation of the CHAWS instrument. The most significant item of concern was oscillatory behavior on the high voltage output above a certain threshold voltage, suggestive of arcing or plasma discharge type activity occurring somewhere within the instrument. In addition, a low voltage output went into what appears to be current limited mode, in a manner correlated to the appearance of this high voltage anomaly. During the course of several discussions sessions held during the report interval, the possible origins of the problem were winnowed and it now rather clear that indeed something was short circuiting somewhere within the instrument. However, the event site appears to be removed from the power supply board itself, for both visual inspection and instrument performance provided no evidence that this location is the origin of the problem.

The redesigned *wedge and strip* anode was received in-house during the report period, and after an initial and quite rudimentary inspection, it appears to have been fabricated in the desired fashion. However, a more rigorous performance test is necessary before a final determination can be made. This has not yet been carried out. A meeting with PL/GPSP personnel was held to discuss a flight opportunity for an instrument incorporating the anode. It was concluded though, that much work remains to be done to bring the rest of the instrument (an Ion Drift Meter) to a state where it could begin to make use of the greatly enhanced spatial resolution of the *wedge and strip* anode.

7.0 TASK #3—OEDIPUS-C EFFORTS

7.1 Summary of Activities

The task of designing and building the electronics module for the EPI instrument on OEDIPUS-C was accomplished during the report period. Two flight boxes and a spare, are now fully assembled and in-house. Test software was written to exercise the functionality of the constituent elements (Interface Board, CPU Board, High Frequency Board, MMU Board) within the instrument, and all indications are that the hardware design is functioning as it was intended. Final flight software was also written, although to date full functionality has only been verified for the CPU and MMU boards. No additional modification is envisaged to either hardware or software, for both these modules at this stage. Software for the High Frequency and Interface boards has been functionally verified in simulation, but proper functionality with the actual flight hardware has not yet been done. Some modifications to the software for these modules may be necessary before final flight configuration is attained.

The following is a detailed account of the measurements to be made by, and functionality of, the EPI sensor and its Electronics Module on the OEDIPUS-C mission.

7.2 EPI Measurements: Particle Spectra; Correlation; & High-Time Resolution

7.2.1. Background of OEDIPUS-C EPI Instrument

OEDIPUS-C is a tethered payload pair with a high frequency transmitter located in one, a synchronised receiver in the other, and with plasma diagnostic experiments in both payload sections. The tether will be aligned parallel to the earth's magnetic field and will be cut around apogee. Each 3 s period (major frame) the transmitter does 5 complete frequency sweeps of a total of 160 frequency steps over 0.5 s (minor frame), either 0.025–7.975 MHz (SH3) or 0.5–2.12 MHz (SH4). Each frequency step duration of 3.03 ms corresponds to an electron analyser energy step and the transmitter will be operated in a single pulse of 300 μ s or 600 μ s near the beginning of the 3.03 ms step period. During the last 0.5 s minor frame of the basic 3.0 s period the transmitter is held at fixed frequency, probably at 4.525 MHz.

Identical electron spectrometers will be mounted on both payload sections. Each spectrometer has an entrance fan split into 8 look directions with 8 CEM detectors. The full electron energy range is covered in 32 energy steps. An energy step offset is applied each major frame to ensure complete energy-frequency coverage over a minimum number of major frames. Identical particle correlation processing is applied in both payloads.

The 32 step energy sweep does not give an integral number of sweeps per minor or major frame. The major frame is 31 full sweeps plus 30 steps long. With the increased telemetry allocation all processing is now done on an energy sweep basis throughout the major frame.

7.2.2. EPI Electronics Module Functions

The EPI CPU is used to process electron pulse arrivals from the eight detection zones of the EPI spectrometer instrument, and to synchronise the spectrometer energy stepping with the major frames. Electron processing includes normal electron energy spectrogrammes, high frequency (0-8 MHz) electron auto-correlations, and high time resolution (90 μ s) histogrammes of the electron response to transmitter pulses. The following hardware are incorporated into the Electronics Module:

(A) Normal Electron Spectra (Counters)

Electron pulses are counted by eight 16 bit counters directly accessible by the CPU bus. The counters are read at the end of each energy step to generate a normal electron spectrogramme. These counts will be log scaled down to 8 bits.

(up to) 32 sweeps x 32 energies x 9 bytes \Rightarrow 9,216 bytes / major frame \Rightarrow 24,576 bits/s

The nine byte values are the energy step number plus the 8 individual log scaled counts at that energy.

(B) High Frequency Units (HFU)

Particle correlation is used to look for modulations caused in the particles when the transmitter frequency corresponds to a plasma resonance. High frequency correlation in the range 0 to 8 Mhz (transmitter frequency range) will use the 'buncher technique' used on SPREE. In order to minimise the data and hardware requirements the eight CEM pulse outputs are 'OR'ed into 4 pulse stream pairs. Energy analysis is done in pairs of adjacent energies since the frequency difference is also small between adjacent frequency steps. Each of four HFUs will generate 2 dimensional histogrammes - 16 energies x 32 lags. As each histogramme is now read out once per energy sweep the values are small enough to transmit only byte wide values.

4 hfu x (up to) 32 sweeps x 16 energy pairs x 32 lags (byte) \Rightarrow 65,536 bytes / major frame
 \Rightarrow 174,762 bits/s

As the total data from HFU within a major frame can be up to 65,536 bytes a whole segment of the 80C286 memory is devoted to this data.

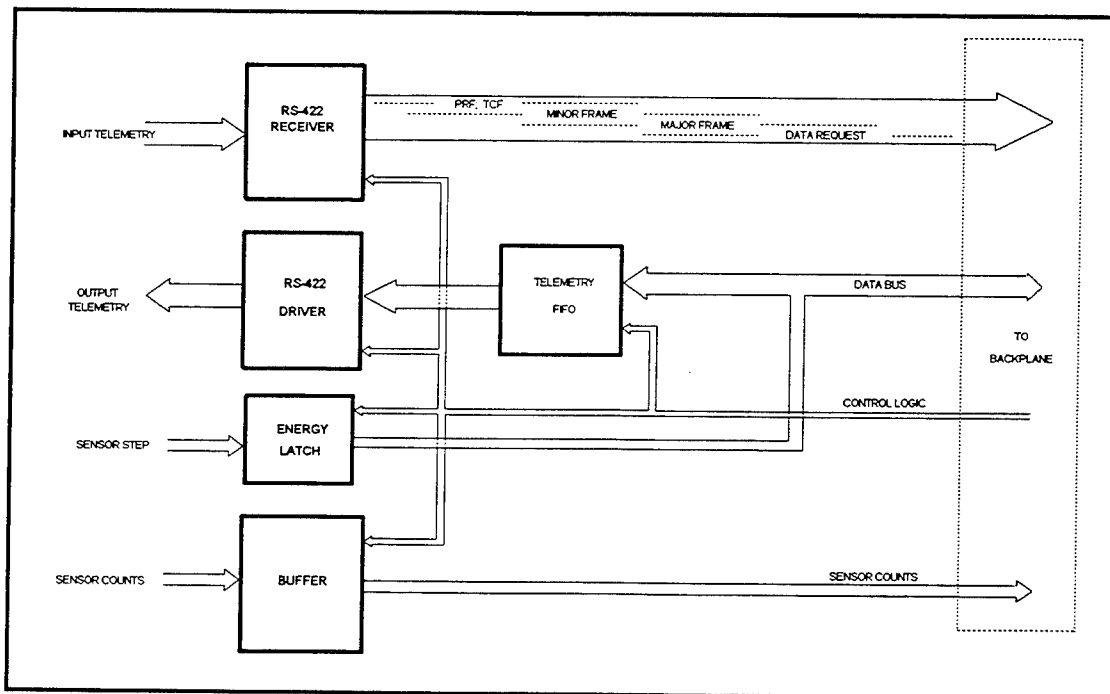

FIGURE 17: INTERFACE BOARD SCHEMATIC

(C). Time Response, MMU

The time response envelope of any flux change caused by the transmitter pulse is measured by sampling during each energy step in 32 equal time bins of 90us with the results again summed over adjacent energy level pairs. Again histogramme values are small enough to use 8 bits. The input streams used are the same 4 OR'd channels as used by the HFUs.

4 mmu x (up to) 32 sweeps x 16 energy pairs x 32 lags (byte) \Rightarrow 65,536 bytes / major frame
 \Rightarrow 174,762 bits/s

As the total data from MMU within a major frame can be up to 65,536 bytes a whole segment of the 80C286 memory is devoted to this data.

(D) Central Processing Unit, CPU

All inputs into the EPI Electronics Module are accessible to the CPU. In addition; the CPU has direct interface with the MMU and HFU. It outputs telemetry via a FIFO buffer.

7.2.3. EPI Electronics Module CPU Interface

The following inputs are accessible to the CPU from the Electronics Module interface:

- (a) 8 electron pulse streams
- (b) PRF pulses
- (c) Major frame toggle
- (d) pre-cut/post-cut flag
- (e) telemetry data request
- (f) Energy level

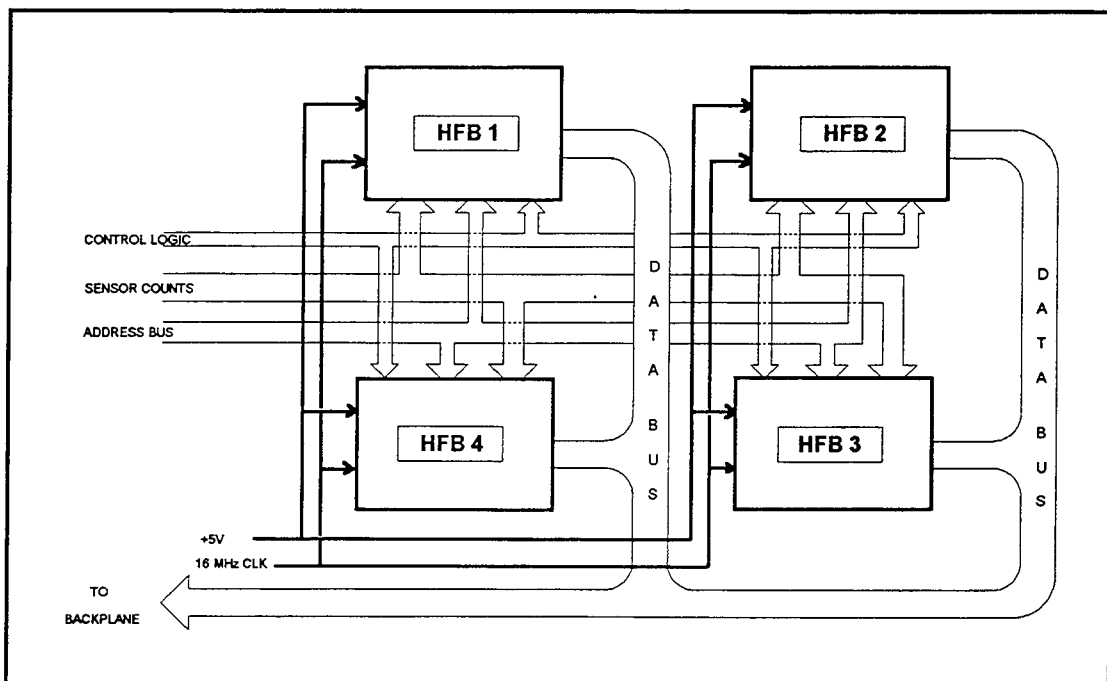

FIGURE 18: HIGH FREQUENCY BUNCHER BOARD SCHEMATIC

7.2.4 Data Format

The EPI Electronics Module outputs data from the CPU in one combined stream. The data in the CPU is double buffered, with one buffer corresponding to the previous major frame's measurements being read out to the telemetry, while the other is being prepared with the current major frame's measurements. The sequence of the data is as follows:

7.2.4.1. Four Byte Label:

- (i) & (ii) 5AH , A5H two synch bytes for start of major frame
- (iii) Status byte
 - Bit 0 - Tether Cut Flag
 - Bit 7 - Processor Error
- (iv) Frame Counter 8 bit free running internal frame counter

7.2.4.2 Spectra Data

The next 9,216 bytes are in time sequence of actual energy steps throughout the frame. Each 9 bytes output per energy level are that next energy level value followed by the 8 log counts of the 8 input streams summed over the previous energy level.

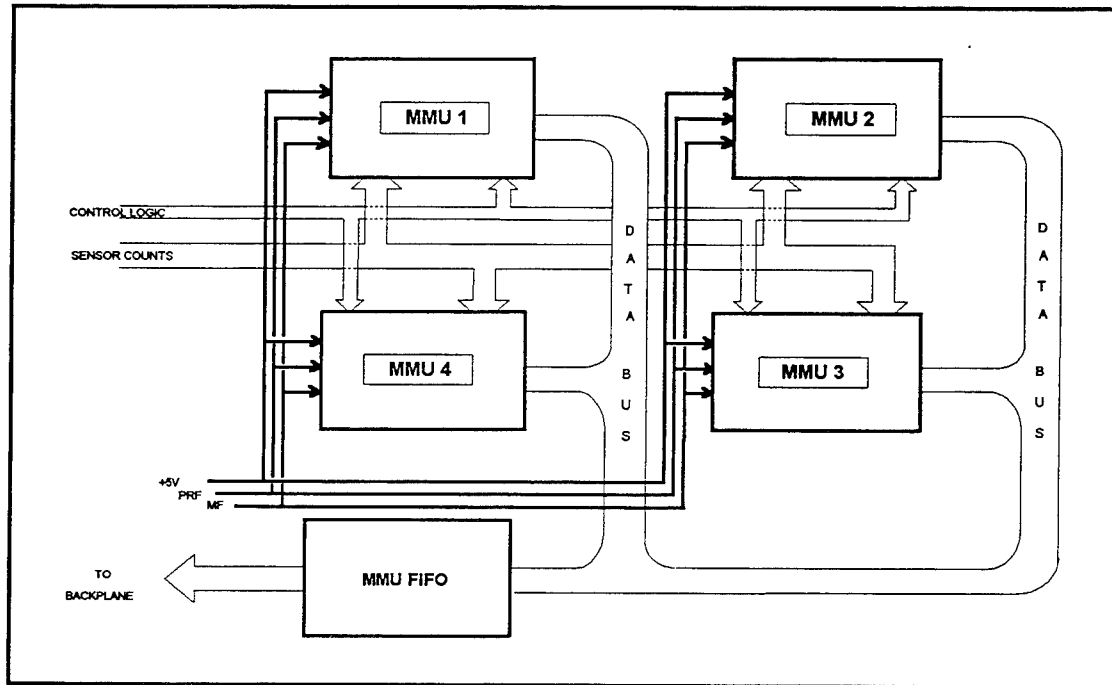

FIGURE 19: MICROCONTROLLER BOARD SCHEMATIC

7.2.4.3 MMU Data

The first two bytes of this block of 65,536 bytes are the synch values: 5AH, 55H

The data following the synch bytes is then ordered in time with a block of 2,048 bytes MMU data for each block of 32 actual energy levels through the major frame starting from the first in the frame. Each block of 2,048 bytes is 512 bytes from MMU unit 1,..512 bytes MMU 2,..512 bytes MMU 4. Each MMU being data from a pair of the 8 electron input streams. Each block of 512 bytes are lags 1 to 32 energy pair 1, lags 1 to 32 energy pair 2, etc to energy pair 16.

7.2.4.4 HFU Data

The first two bytes of this block of 65,536 bytes are the synch values: 5AH, AAH

The data following the synch bytes is then ordered in time with a block of 2,048 bytes HFU data for each block of 32 actual energy levels through the major frame starting from the first in the frame. Each block of 2,048 bytes is 512 bytes from HFU unit 1,..512 bytes HFU 2,..512 bytes HFU 4. Each HFU unit being data from a pair of the 8 electron input streams. Each block of 512 bytes are lags 1 to 32 energy pair 1, lags 1 to 32 energy pair 2 etc. to energy pair 16.

7.2.5 Overall Data Rate

A breakdown of the constituent elements within the telemetry stream which are outputted by the CPU is as follows:

	Total bytes/major frame	Bits per second
HFU	65,536	174,762
Time	65,536	174,762
Spectrum	9,216	24,576
Major Frame Label	4	11
<hr/>		
Total	140,292	374,111

For a 800s flight, the overall rocket flight data will amount to some 38 Megabytes per payload and could easily be stored on the hard disc of the PC used to analyse the data post-flight.

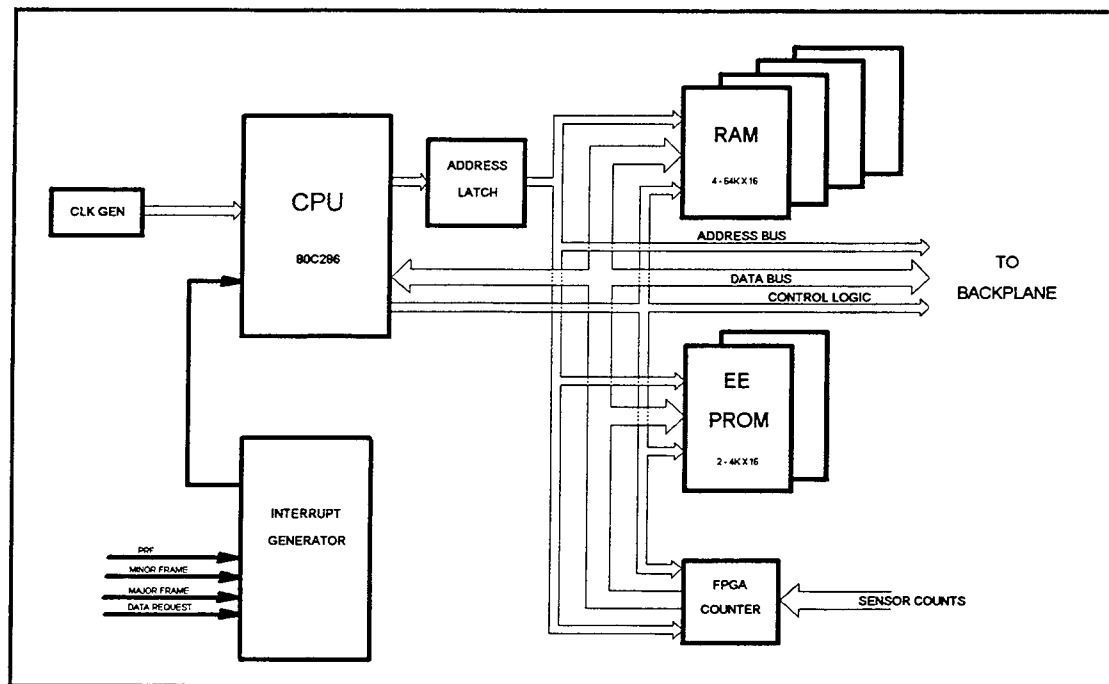

FIGURE 20: CENTRAL PROCESSOR BOARD SCHEMATIC

7.3 EPI Software: Functionality and Code Outline

There are two main software modules which control the operation of the EPI Electronics Module. They are: (i) the MMU module and (ii) the CPU module. The former acquires data from the particle counters and processes it in a correlated fashion along with the changes in transmitter frequency. The output from this module is fed into the CPU module, which packages the data in the requisite output telemetry format. Communication with the rocket's payload interface unit and instrument initialization tasks are also functions handled by the CPU software module. The interfaces for each module and the functionality of the modules themselves are outlined below.

7.3.1. Software Pseudo-Program for MMU:

7.3.1.1. Interfaces:

T0: Particle Counter
INT0: PRF input from CPU
INT1: Request for output from CPU
P1.0-P1.7: Tristate O/P to FIFO buffer for data to CPU
TXD: Output to OR'd FIFO clock input
RXD: Input hardware toggled at major frame

Note: Energy sweep data is double buffered within MMUs. Data from last sweep is read out from the output buffer while this sweeps data is accumulating in the active buffer. Note that the MMU does not know about real sweeps, only energy level changes. So the MMU processes data in groups of 32 PRF energy levels starting with the first in the major frame.

7.3.1.2. RESET & POWERUP INITIALISATION:

send FFH to P1 since tristate and shared by other units
enable inputs and set FIFO clock high as shared by other units
initialise Altera chip
energy_level=0
reset o/p_request_flag
fill o/p buffers with initial dummy test data ramps (1st time only)
active_data_uffer = low
op_data_buffer = high
set mode of T0 counter for electron pulse counting
enable INT0 and INT1 interrupts (PRF and o/p request)

WAIT:

endless wait loop
goto wait
(All processing done by interrupts away from here)

7.3.1.3. INT1: o/p request from CPU

Set output_request_flag
Return to wait loop

7.3.1.4. INT0: next prf

IF RXD toggled (new major frame) THEN GOTO NEW_ENERGY_SWEEP

Energy_level = Energy_level + 1

IF Energy level < 32 THEN GOTO OP_TEST

NEW_ENERGY_SWEEP:

energy_level = 0;

swap over active_data_buffer and output_data_buffer pointers

OP_TEST:

IF output_request_flag set THEN GOTO OUTPUT

This section is data take for this energy level

Generate base pointer for data using active_data_buffer and Energy_level / 2

last_sample = read of T0; (presample)

90 μ s software delay

FOR time = 1 to 32

this_sample = read of T0;

count = this_sample - last_sample;

last_sample = this_sample

IF Energy_level is first of pair OR first of pair was zapped by o/p request THEN

data_buffer(base_pointer +time) = count

ELSE (second of pair of data sets being summed)

data_buffer(base_pointer +time) = data_buffer(base_pointer+time)

+ count

ENDIF

90us software delay

NEXT time

RETURN FROM INTERRUPT

(return to main WAIT loop)

7.3.1.5. OUTPUT: (this prf energy level is zapped by o/p request- only one set of data goes into this energy pair)

set energy zapped flag

reset output_request_flag

FOR i = 1 to 512

P1 = output_data_buffer (i) ; Output to FIFO

Toggle TXD ; Clock FIFO

NEXT i

P1 = FFH Shared lines

OP FIFO Clock high Shared line

RETURN FROM INTERRUPT

(return to main WAIT loop)

7.3.2. Software Pseudo-Program for CPU:

7.3.2.1. Interfaces:

INTERRUPTS:

PRF Interrupt from HEX

Telemetry Request Interrupt

OUTPUTS:

Data to Telemetry FIFO

Port -Energy level to HFU

Port -Request MMU data units 1 - 4

Port -Clear MMU FIFO

INPUTS:

Address mapped HFU

MMU FIFO

Address mapped 16bit counters

Port -Major Frame Toggle

Port -Tether Cut Flag

Port -Energy Level Log. 8 bits

Note data inside CPU is double buffered. Data is output this major frame from last major frame

7.3.2.2. RESET & POWERUP:

Setup Stack

fill both buffers with ramping numbers

clear/ reset o/p fifo

setup all pointers

prepare labels

setup interrupt controller

enable interrupts

MAINLOOP:

(In background continously loops through three sections: MMU_IP, TELEM_OP, HFU_IP)

MMU_IP:

IF MMU_Ready SET THEN

Copy 2048 bytes (4units x 16 energy pairs x 32 lags) from MMU FIFO to MMU segment of active_buffer

Update LF pointer copy

Reset MMU FIFO

Reset MMU_Ready

ENDIF

TELEM_OP:

IF OP_REQ SET THEN

Copy 8 kbytes from op_buffer to TELEM FIFO

Update pointers, segment pointers etc

Reset OP_REQ

Clear Telem_INT

ENDIF

```

HFU_IP:
IF HFU_Ready SET THEN
  Copy 2048 bytes from HFU_Temp_Buffer to HFU segment of active_buffer
    (converting word boundaries to bytes)
  Update HF pointer copy
  Reset HFU_Ready
ENDIF
GOTO MAINLOOP

```

7.3.2.3. Interrupts:

PRF INTERRUPT: (Main Time Critical Processes)

IF major_frame toggled THEN (Start of New Major frame)

Increment frame counter

Copy Tether cut bit to status byte

Swap all active buffer and output buffer pointers etc

energy_level= -1

Prepare 1st four label bytes and MMU and HFU labels

ENDIF

Copy 8-bit Energy Value from port to Strectra data buffer

Read all 8 counters and copy to spectra data buffer

Reset counters

restart counters

increment energy_level

If energy_level >31 then energy_level=0 (32 values 0-31 continuous thru frame)

Copy energy_level / 2 to HFU energy port (16 values 0-15 for pairs of levels)

IF energy_level=0 THEN (Just finished another 32 energy steps)

disable all HFU

For hfuno=1 to 4

Copy HFU data to HFU_Temp_Buffer (16energy pairs x 32 lags)

Next hfuno

enable all HFU

set HFU_Ready Flag

ENDIF

IF energy_level=10H THEN send data request to MMU 1

IF energy_level=12H THEN send data request to MMU 2

IF energy_level=14H THEN send data request to MMU 3

IF energy_level=16H THEN send data request to MMU 4

If energy_level=18H THEN set MMU_Ready Flag

RETURN (TO MAINLOOP)

TELEMETRY REQUEST INTERRUPT:

Set OP_REQ Flag

RETURN

PROCESSOR ERROR INTERRUPT:

Set Status bit 7

RETURN