

O

AR-009-205

DSTO-TN-0004

T

Preparation of S-70A-9 Black Hawk Helicopter for Flight Tests to Investigate Cause of Cracking of Inner Fuselage Panel

D.C. Lombardo, A.K. Patterson, P. Ferrarotto, S.A. Dutton, I.G. Powlesland and K.F. Fraser

S

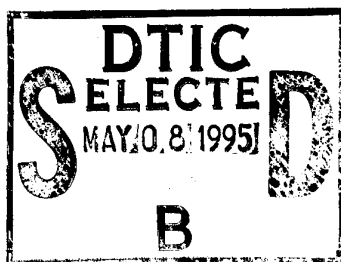

APPROVED FOR PUBLIC RELEASE

D

19950504 110

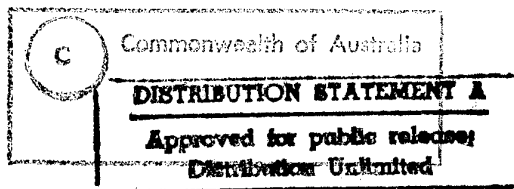

T

DTIC QUALITY INSPECTED

THE UNITED STATES NATIONAL  
TECHNICAL INFORMATION SERVICE  
IS AUTHORISED TO  
REPRODUCE AND SELL THIS REPORT

# Preparation of S-70A-9 Black Hawk Helicopter for Flight Tests to Investigate Cause of Cracking of Inner Fuselage Panel

*D.C. Lombardo, A.K. Patterson, P. Ferrarotto, S.A. Dutton,  
I.G. Powlesland and K.F. Fraser*

**Airframes and Engines Division  
Aeronautical and Maritime Research Laboratory**

DSTO-TN-0004

## ABSTRACT

An Australian Army Black Hawk helicopter has been fitted with suitable flight test instrumentation at the Aeronautical and Maritime Research Laboratory to enable an investigation of the cause of cracking in an internal fuselage skin panel. Nine accelerometer channels and 46 strain gauge channels have been provided. Reasons for the choice of measurement type and location are provided together with details of the measuring system installed. Plans for the conduct of suitable flight tests and for the evaluation of the collected data are provided.

*Approved for public release*

DEPARTMENT OF DEFENCE

---

DEFENCE SCIENCE AND TECHNOLOGY ORGANISATION

DSTO Aeronautical and Maritime Research Laboratory  
PO Box 4331  
Melbourne Victoria 3001 Australia

Telephone: (03) 626 7000  
Fax: (03) 626 7999  
© Commonwealth of Australia 1995  
AR No. 009-205  
February 1995

<b>Accession For</b>	
RTIS GRA&I	<input checked="" type="checkbox"/>
DTIC TAB	<input type="checkbox"/>
Unannounced	<input type="checkbox"/>
Justification _____	
By _____	
Distribution/ _____	
<b>Availability Codes</b>	
<b>Dist</b>	<b>Avail and/or Special</b>
A-1	

APPROVED FOR PUBLIC RELEASE

# Preparation of S-70A-9 Black Hawk Helicopter for Flight Tests to Investigate Cause of Cracking of Inner Fuselage Panel

## EXECUTIVE SUMMARY

1. Many S-70A-9 Black Hawks in the Australian Army fleet are experiencing cracking in the right-side internal fuselage skin panel that lies between fuselage frames FS295 and FS308.
2. Since the Australian Army suspects that the carriage of fuel tanks via the External Stores Support System (ESSS) is responsible for the cracking, they have suspended all ESSS operations pending an investigation of the cause of the cracking.
3. In view of the severe constraints being imposed on Black Hawk operations, an urgent request was placed on the Aeronautical and Maritime Research Laboratory (AMRL) to participate in the preparation for and the conduct of a flight test investigation.
4. Helicopter A25-206, which is assigned to the Aircraft Research and Development Unit (ARDU), was flown to AMRL on 30 November 1994 for the fitting of appropriate sensors and recording equipment.
5. Strain gauges have been fitted to both left and right panels. The positioning of some of the panel gauges conforms with advice which has been received from Sikorsky. Strain gauges and accelerometers have been fitted to each ESSS "wing" and strain gauges have been fitted to their associated struts.
6. Signal conditioning units, recording equipment etc. have been mounted in a rack used previously in ARDU flight tests on Black Hawk. The rack attaches to the floor of the aircraft, between the loadmaster's windows after removal of the fore/aft seating.
7. The flight test installation was checked during a ground run of the test aircraft with rotors turning on the AMRL helipad on 18 January 1995. Correct operation of the system was verified after examination of the recorded data.
8. The various aircraft configurations requiring separate flight tests, and the flight conditions for which data are to be recorded, have been defined.
9. The methods which will be used for ground system analysis of the collected data have been defined.
10. Flight testing is scheduled to commence on 7 February 1995 and terminate by 24 February 1995.

# Contents

1. INTRODUCTION .....	1
2. POSSIBLE CAUSES OF CRACKING .....	1
3. AIM OF FLIGHT MEASUREMENTS PROGRAM .....	3
4. REQUIRED MEASUREMENTS.....	3
5. AIRCRAFT FLIGHT TEST CONFIGURATIONS.....	4
6. FLIGHT TEST CONDITIONS .....	5
7. FLIGHT TEST INSTRUMENTATION .....	6
7.1 Measurand Sensing System .....	6
7.2 Rack-Mounted Instrumentation .....	7
7.2.1 General .....	7
7.2.2 Signal Conditioning .....	7
7.2.3 Three-axis Aircraft Accelerometer Pack .....	7
7.2.4 Recording System.....	8
7.2.5 Power Supplies.....	8
7.2.6 Instrumentation Rack.....	9
8. SENSOR CALIBRATION .....	9
9. MEASUREMENT SYSTEM VERIFICATION.....	9
10. DATA RECORDING AND IDENTIFICATION.....	10
11. DATA STORAGE.....	11
12. GROUND STATION DATA PROCESSING.....	11
12.1 Data Format Conversion .....	11
12.2 Data Analysis.....	12
13. PROGRESS AND FUTURE ACTIONS.....	13
14. CONCLUDING REMARKS.....	14
ACKNOWLEDGMENTS.....	14
REFERENCES.....	15
TABLE 1 Summary of Cracked Panels for 5 Aviation Regiment (Townsville) Aircraft (as at 5/8/94).....	16
APPENDIX A: Data Acquisition Control Program for DARTH.....	17
APPENDIX B: Instructions for Ground Station Data Processing .....	21
FIGURES 1-15.....	23-39

## Abbreviations

AMAFTU	Aircraft Maintenance and Flight Trials Unit
AMRL	Aeronautical and Maritime Research Laboratory (DSTO Laboratory in Melbourne)
ARA	Australian Regular Army
ARDU	Aircraft Research and Development Unit (RAAF unit at Salisbury)
Army LM Sqn	<i>Army Aircraft Logistics Management Squadron</i> (Army Base Oakey)
DARTH	Data Acquisition and Real Time Hardware
DSTO	Defence Science and Technology Organisation
DT&E	Development Test and Evaluation
ESSS	External Stores Support System
MR	Main Rotor
NDI	Non-Destructive Inspection
NSM	Non-Standard Modification
PC	Personal Computer
RAAF	Royal Australian Air Force
RAM	Random Access Memory
RAN	Royal Australian Navy
VAC	Volts Alternating <i>Current</i>
VDC	Volts Direct <i>Current</i>

## 1. Introduction

Many S-70A-9 Black Hawks in the ARA fleet are experiencing cracking in the internal skin panel that lies between fuselage frames FS295 and FS308 (Figs 1 and 2). Cracking has been confined to the right-hand panel and Fig. 3 shows the location of the cracks in the panel in the worst-affected aircraft (A25-104). Table 1 provides a summary of the cracks found in 5 Aviation Regiment (Townsville) Black Hawks.

Since the ARA suspects that the carriage of fuel tanks via the External Stores Support System (ESSS) is responsible for the cracking, they have suspended all ESSS operations. This is causing severe operational hardship for the ARA because, without the ESSS tanks, the Black Hawk has insufficient range and/or endurance to adequately perform its role.

In view of the severe constraints being imposed on Black Hawk operations, Army LM Sqn raised an urgent DT&E (Development, Test and Evaluation) request<sup>1</sup> for ARDU and AMRL to investigate the panel cracking problem. The DT&E requested ARDU and AMRL to conduct an appropriate flight measurements program in the shortest possible time to determine the sources and characteristics of the loading on the panel.

AMRL drafted a proposal<sup>2</sup> for meeting the DT&E requirement. Agreement-in-principle was received and the ARDU's Black Hawk test aircraft A25-206 was flown to the AMRL helipad (Figs 4 and 5) on 30 November 1994 to be prepared by AMRL staff for flight testing. After the cable routing requirements had been determined, the main rotor blades and the ESSS were removed, and the aircraft parked in the hangar for the fitting of sensors, cables etc.

This report details AMRL's flight investigation plan including the aircraft modification. A further report on the flight tests and the evaluation of the data collected will be issued after the tests have been completed.

## 2. Possible Causes of Cracking

The External Stores Support System (ESSS) (Fig. 6) is suspected of aiding, and possibly causing, the panel cracking. There are several reasons why this might be the case:

- (a) ESSS loads are reacted by the two frames FS295 and FS308. A NASTRAN analysis of the ESSS loads performed by Sikorsky<sup>3</sup> (pp A.8.13 and A.9.7) shows that the ESSS loads are not equally distributed between the two frames. Consequently, torsional loading, which will induce shear stresses, will be experienced by the panel. The geometry

of the crack growth in the panels (Fig. 3) is consistent with the panel undergoing shear loading.

- (b) The ESSS loads are significant. The ESSS, without tanks, weighs<sup>4</sup> 300 lb per side. Each tank, weighs 150 lb without fuel, and the fuel weight is approximately 1500 lb/tank. Therefore, the complete ESSS with four full fuel tanks adds about 7200 lb to the aircraft gross weight.
- (c) In addition there is anecdotal evidence from the operators. One aircraft, after having its panel repaired according to a standard Sikorsky repair scheme, flew approximately 50 hours without the ESSS and without any observable crack growth in the panel. The ESSS was then installed and the aircraft flew a further 15 hours during which the formation and growth of new cracks were observed. This would indicate that the ESSS was a contributing factor to the growth of the panel cracks provided that the type of flying done by this aircraft with the ESSS was similar to the type of flying done without the ESSS.

Another source of loading on the FS295/FS308 frames is the forward fuselage. The entire weight of the forward fuselage is supported in a cantilevered fashion from the main landing gear which is located between FS295 and FS308.

Possible sources of dynamic loading on the panel are:

- (a) Aerodynamic interaction between the Main Rotor (MR) wake and the ESSS causing the ESSS to vibrate excessively during flight.
- (b) Flapping of the ESSS during landing due to the inertial loads of the ESSS and fuel tanks.
- (c) Inertial loading from the forward fuselage during landing.

Both (a) and (b) above definitely produce non-symmetrical loading on the left and right hand sides of the aircraft. The MR rotates anti-clockwise when viewed from above and so its effects on the overall airflow over the fuselage differ from one side of the aircraft to the other. As for landing loads, the Black Hawk left main wheel touches down before the right main wheel. In such a situation, the aircraft will rotate about the left main wheel until the right main wheel touches down. This adds rotational motion to the vertical translational motion of the right main wheel which increases the velocity with which it hits the ground.

One item that may have a bearing on the crack growth is the method for rigging (installing) the fuel tank racks onto the ESSS. In August 1992, a Special Technical Instruction (STI-BLACKHAWK-62) was issued which altered the rigging procedure. The original procedure was to tighten rack bolts by hand and then to use a spanner until the nuts rotated sufficiently to allow split-pins to be inserted. The STI banned the use of the spanner and, instead, specified that once the nuts were hand-tightened, they were to be *undone* until the split-pin could be inserted.

### 3. Aim of Flight Measurements Program

The aim<sup>1</sup> of the flight trial measurements program is *"to determine the most likely cause of the panel cracking"*. This will require determining the loads applied to the panel under selected flight conditions and aircraft configurations. Both the amplitude and frequencies of the applied loads are required.

The program is predicated around the assumption that the ESSS is a significant contributor to the cracking problem. However, if the ESSS were found not to produce significant loads in the panel then the operational restriction on the ESSS could be removed as it would be seen to serve no purpose.

### 4. Required Measurements

Both strain and acceleration are to be measured.

Three accelerometers are placed on each ESSS "wing" as shown in Fig. 7, making a total of six accelerometers. Such a configuration allows the vertical bending, fore/aft bending and pitching motions of the "wing" to be determined. Figure 7 also defines identification codes for each accelerometer.

Three accelerometers inside the aircraft enable body accelerations to be measured (the identification codes for these three channels are CGX, CGY, and CGZ for the x, y, and z accelerations respectively).

Figure 8 shows the number of strain gauges, their type and locations, and their identification codes. The required number of strain gauge channels is 46. The strain gauge locations on the ESSS have been set to allow determination of the stresses in the internal wing spars and the bracing struts as the loads are transmitted from the ESSS to frames FS295 and FS308 via these spars. The locations of strain gauges SRP2 – SRP5 on the right hand internal panel have been set to coincide with the areas of maximum stress as evidenced by the occurrence of cracking. The locations of SRP1, SRP6, and SRP7, are based on advice from Sikorsky. The gauges on the left hand panel are used for the purposes of comparison (left panel strains versus right panel strains).

Since aerodynamic interaction may be a problem, the measurements should be made at frequencies up to four times the MR blade passing frequency. Since this is 17.2 Hz, then frequencies up to 70 Hz per channel need to be identified. In addition, the recording of steady state strains is required.

## Summary of transducers:

Transducer	No. on left side of aircraft	No. on right side of aircraft	Total on aircraft	Channels per transducer	Total Channels	Digital or Analogue
ESSS accelerometers*	3	3	6	1	6	A
Aircraft accelerometers*	-	-	3	1	3	A
ESSS strain gauges	6	6	12	1	12	A
Panel strain gauges	5 Rosette 2 Uniaxial	5 Rosette 2 Uniaxial	10 4	3 1	30 4	A A
Left/Right indicator*	-	-	1	1	1	D
					56	

The capacity of the chosen recording system (Section 7.2.4) is insufficient to allow all the required signals to be recorded simultaneously (32 analogue and 8 digital channels available versus 55 analogue and 1 digital required). Therefore, it will be necessary to switch some of the left and right-hand strain gauges in and out. Those channels that are to be read all the time are marked with an asterisk in the table above. This reduces the number of analogue channels to be read at any one time to 32. To provide a recorded identification of which gauges (i.e. left or right side) were connected, a left/right indicator signal will be recorded.

## 5. Aircraft Flight Test Configurations

It is proposed that tests be carried out for the following seven flight test configurations:

- (a) Non-ESSS configuration, Gross weight = 16000 lb.
- (b) Non-ESSS configuration, Gross weight = 20000 lb.

Configurations (a) and (b) will set a baseline for panel strains. The gross weight values were chosen as being representative of ARA Black Hawk operations without the ESSS.

- (c) ESSS installed, but without fuel tanks, Gross weight = 20000 lb.

This is the first of the ESSS configurations. The gross weight figure of 20000 lb was chosen as being representative of ARA Black Hawk operations with the ESSS. The other ESSS configurations listed below are to be all at 20000 lb as well.

- (d) ESSS installed with two empty 230 U.S. gallon tanks attached – one to each of the outboard pylons.
- (e) As for (d), but the tanks are now half full.
- (f) As for (d), but the tanks are now full.
- (g) ESSS installed with four tanks attached (all of 230 U.S. gallon capacity). All tanks are full of fuel.

The effects of the rigging change (Section 2) will need to be determined. Therefore, it will be necessary to duplicate some or all of the ESSS configuration test flights with the old rigging procedure. The most likely configurations to be duplicated are (e) and (f).

The flight test configurations defined above are subject to review. Configurations may be changed and/or new configurations added during the conduct of the flight investigation if the data analysis indicates that such action is necessary.

## 6. Flight Test Conditions

The following flight conditions should be flown during each test flight for each configuration *provided that they are within the allowable flight envelope and that they are typical flight conditions for the configuration*:

- (a) Level flight from hover to  $0.9V_H$  ( $V_H$  = maximum level flight speed). Recordings are to be taken at hover,  $0.3V_H$ ,  $0.5V_H$ ,  $0.7V_H$ , and  $0.9V_H$  (i.e. five separate flight conditions).
- (b) Left and right hand turns at  $30^\circ$  and  $45^\circ$  angles-of-bank at two speeds:  $0.5V_H$  and the maximum allowable speed. (i.e. four separate flight conditions).
- (c) Moderate pull-outs (1.8g) at the maximum allowable speed.
- (d) "Normal" landings – the type that are done when Black Hawks land on their prepared airfields at Townsville and Oakey.
- (e) "Operational" landings – the type that are done when Black Hawks land in dusty areas. That is, rapid rates of descent with a high nose-up attitude.

The above flight conditions (12 in all) were chosen with the aim of ensuring that both ESSS aerodynamic interaction loads and inertial loads will be induced. As for the aircraft configurations, the above flight conditions are not necessarily fixed. Flight conditions may be deleted and/or new ones added during the conduct of the flight trial if the data analysis indicates that such action is necessary.

## 7. Flight Test Instrumentation

### 7.1 Measurand Sensing System

Measurand sensing is achieved via a Non-Standard Modification (NSM) which comprises the attachment of strain gauges and accelerometers to aircraft surfaces, and the incorporation of electrical wiring and connectors to interface the sensor circuits to associated signal conditioning units in the equipment rack.

For the purposes of incorporating the modification, the ESSS wings were removed from the aircraft for the fitting of sensors and wiring. The two struts on each wing were detached from the wings for strain gauge attachment and calibration, and wiring.

Single element strain gauges in full four active arm bridge configurations have been installed for the ESSS and strut gauge stations. Five planar rectangular rosettes (three-element) and two uniaxial gauges have been installed on each of the right and left side panels for the panel strain measurements, using quarter bridge configurations, with bridge completion networks assembled from single element gauges on dummy plates located close to the active gauges.

All gauges have been fully waterproofed with a non-corrosive RTV silicone (Dow Corning 3145). All materials have been tested for compatibility with aircraft materials.

The strain gauges are arranged in two groups, one for gauges on the left side of the aircraft and one for gauges on the right side of the aircraft. Only one group can be recorded at a time. Switching between groups is effected at the input to the amplifier modules, by connecting the loom from the selected group to the input connectors on the instrumentation rack. The looms include wiring which automatically identifies the group selected for recording. To allow switching in this way it was necessary to ensure that each strain gauge bridge has a similar initial offset to the corresponding strain gauge bridge on the opposite side.. This has been achieved by trimming the bridge offsets on the left side. For the panel gauges this has been done on the bridge completion dummy plate assemblies. For the remaining gauges, which do not require dummy plates, trimming resistors have been installed on the gauge station terminal strip.

PCB1459 accelerometers with a range of  $\pm 50g$  and response from 1 to 100 Hz are installed near the outer edges of the ESSS wings to measure vibration characteristics. These accelerometers are 0.23 inch in diameter, 0.3 inch high, and have a mass of 0.5 grams. They have been glued to the test structure with a cyanoacrylate adhesive and waterproofed with a non-corrosive RTV silicone (Dow Corning 3145).

Wiring from the strain gauge stations and accelerometers to the instrumentation rack has been done with screened and jacketed twisted quad cables (Raychem type 44). Cables from the external gauge stations have been provided with disconnects near the point of entry to the fuselage.

Transducer wiring is defined in the AED Instrumentation drawings 801, 803, 805, 807, 809, 811, 813, 815, 917, 920, 922, 924, 926, 928, 930, 955 and 957. All strain gauge and ESSS accelerometer installations have been photographed. Strain gauge connections to the inner fuselage panel are illustrated in Fig. 9. Accelerometer and strain gauge connections to the ESSS are illustrated in Figs. 10, 11 and 12.

## 7.2 Rack-Mounted Instrumentation

### 7.2.1 General

The instrumentation items outlined in Secs 7.2.2 to 7.2.5 are housed in a special rack (Sec. 7.2.6). The rack and the equipment it contains are also treated as a NSM. A block schema of the instrumentation system showing sub-system interconnections is provided in Fig. 13. A photograph of the equipment rack is provided in Fig. 14.

### 7.2.2 Signal Conditioning

Two strain gauge signal conditioning units are installed in the equipment rack. Each accommodates six dual-amplifier plug-in modules, giving 12-channel capacity for each unit. Each amplifier module has self contained constant-current bridge supplies and shunt verification facilities. Amplifier gains are presettable and offsets are adjustable. The frequency response of the amplifiers is DC to 500 Hz (-3 dB) approximately. Input and output connectors for the strain gauge signal conditioning units are D-style. This equipment has been extensively used in AMRL/ARDU flight trials in the past. AED Instrumentation drawings 801, 803 and 815, and AMRL drawing 55585A1 define this signal conditioning equipment.

The vibration accelerometers on the ESSS require a constant current source and isolating capacitor. The required current for the accelerometers is supplied via a commercial power unit which also provides power for the associated signal conditioners. This power unit, a PCB, 6-channel, rack-mounted power unit F483B08, was used in the Black Hawk gearbox vibration monitoring trials conducted in 1993. In consultation with the equipment supplier the unit has been converted to run from the aircraft 110 VAC 400 Hz supply.

### 7.2.3 Three-axis Aircraft Accelerometer Pack

A three axis servo accelerometer pack has been installed in the instrument rack to measure aircraft accelerations. This pack is located close to the aircraft centre of gravity. Power is provided from the instrumentation rack. The aircraft motion accelerometers are high level, low impedance, voltage output devices. No signal

conditioning other than that in the recording system (7.2.4) is needed. Interconnection details are provided in AED Instrumentation drawings 922 and 813.

#### 7.2.4 Recording System

A data acquisition system developed at AMRL and referred to as DARTH (Data Acquisition and Real Time Hardware) is to be used to record the flight test data. DARTH is based on a Dolch IBM-PC compatible computer with an Intel 80486 processor. An extra input signal conditioning assembly is attached to the rear of the computer. It provides amplification and filtering for 32 differential input channels. Gains, which are selectable, range from 1 to 160 (i.e. 1, 2, 4, 8 and 16 with a further gain of 10 on the analogue-to-digital converter board). Low pass filter cutoff frequencies are user-selectable, the highest being 100 Hz. The filters are eighth order elliptical types implemented as a single-chip switched-capacitor filter. Nominal filter parameters are: passband 0 to 100 Hz; passband ripple 0.15 dB; stopband edge 150 Hz; stopband attenuation 72 dB. With the chosen sampling rate of 250 per second this filter will effectively prevent aliasing into the 0 to 100 Hz passband. As DARTH acquires data, it stores the data on a RAM disk. At the end of an acquisition run, the data are written to a hard disk and the RAM is then available for the next run.

The Dolch computer, but not the signal conditioning attachment, has previously flown on a Black Hawk helicopter with ARDU during the Gearbox Vibration Monitoring Trial in July 93. Two DARTH units were produced. One is currently installed in a RAN Seahawk helicopter based at the Aircraft Maintenance and Flight Trials Unit (AMAFTU) at Nowra. The other is to be used for this application.

A photograph of the DARTH computer (removed from the equipment rack) is provided in Fig. 15.

Details of the menu-based program used to control data acquisition by DARTH is provided in Appendix A.

#### 7.2.5 Power Supplies

Both the DARTH and accelerometer signal conditioning circuits operate wholly from 115 VAC 400 Hz. The instrumentation rack is fitted with a 5A circuit breaker at the 115 VAC input.

The signal conditioning and transducer power supplies require 28 VDC (< 1A) at the instrumentation rack. The instrumentation rack is fitted with a 5A circuit breaker at the 28 VDC input point.

### 7.2.6 Instrumentation Rack

DARTH, the signal conditioners and associated power supplies, and the three-axis accelerometer pack are installed in the mounting rack that had previously been utilised for the ARDU/AMRL Gearbox Vibration Monitoring Trial. This rack has been structurally tested and can withstand a 20g load.

The rack attaches to the floor of the aircraft, between the loadmaster's windows, after removal of the fore/aft seating. Rack restraint is provided by bolting the foot of the rack to the cabin floor and by straps at the top of the rack which also bolt to the floor.

## 8. Sensor Calibration

Accuracy of strain measurements is primarily dependent on the manufacturer's gauge factor data. Shunt verification facilities are provided on the strain gauge amplifiers for verification of the bridge and signal conditioner gain.

Where possible, strain gauges on a component should also be calibrated in terms of load by applying static known loads to either the component or the aircraft. For the ESSS struts, strain gauge calibration has been achieved by placing the gauged struts in an MTS testing machine, applying tension and compression loads, and thereby obtaining strain versus load calibration curves. Due to uncertainty as to the maximum loads that can be carried by the struts, only low calibration loads were used ( $\leq 12$  kN). If strains recorded during the flight trial indicate that loads well above 12 kN are carried by the struts, then the struts may have to be brought back to AMRL for further loading to extend the calibration curves.

Other strain gauges on the aircraft cannot be calibrated against load as the direction of the applied loading is unknown. However, vertical and drag loads can be applied to the ESSS and these can be used to provide an indication of the strain gauge responses to ESSS loads.

## 9. Measurement System Verification

Verification of the data acquisition system has been completed in stages.

Initially the system was powered from 240 VAC whilst installed in the helicopter to ensure all signals were at expected levels. A static inverter was then used to produce 115 VAC 400 Hz power, as will be supplied by the aircraft in flight. Signals were

measured to check the susceptibility of the system to 400 Hz noise and ensure correct operation from "aircraft power".

Prior to the aircraft leaving AMRL a ground run of the system was conducted. Initially the instrumentation package was powered from the aircraft auxiliary power unit (APU), to confirm the results obtained from the use of the static inverter running on normal mains power. Finally data were collected with the main engines running and rotors turning. During analysis of these data, strain and vibration signals, at very low levels, were found at the fundamental frequency, and associated harmonics, for both the main and tail rotors. Genuine strain and vibration signals at these frequencies were expected.

A final check of the system will involve a "shakedown flight", prior to the actual trial commencing to ensure all gains are appropriately set and that expected signals are present.

## 10. Data Recording and Identification

During the flight tests the operator of DARTH will be in voice communication with the pilot via the aircraft intercom. Both the operator and the pilot will have a copy of the flight test plan.

During the flight test, the operator will indicate the next flight condition to be flown and the pilot will confirm that what the operator asks for, tallies with what he is expecting. Once the next flight condition to be flown has been established, the procedure will differ depending on the flight condition.

For the level flight conditions the pilot will achieve the correct flight speed and then notify the operator to begin recording. The operator will then tell the pilot when enough data have been obtained and recording has stopped. Thirty seconds of flight data will be recorded at each level flight speed.

For all the other flight conditions the pilot will indicate to the operator to begin recording just before achieving the desired flight condition and to stop recording after the condition has been exited. This will enable the loads and accelerations at both entry to, and exit from, the flight condition to be obtained as well as those during the flight condition. For these flight conditions, the amount of data recorded will depend on how long each flight condition takes from entry to exit.

DARTH automatically saves the acquired data to a file, the name of which will be supplied by the operator. Each file name will be chosen to uniquely identify the flight condition, aircraft configuration, and whether left or right-hand side transducers are being read.

## 11. Data Storage

Signal variations of up to 68.8 Hz need to be measured (to accommodate up to four times the blade passing frequency). To do this will require DARTH to operate at its maximum sampling rate of 250 samples/second. A sampling rate of 250 per second across all 32 channels yields a data storage requirement of 12 kb per flying second. The available RAM in DARTH, 4 Mb (with 3 Mb available for the RAM disk), therefore limits a flight condition to about 4 minutes. The hard disk capacity, 80 Mb, limits the number of flight conditions which can be achieved in one session without having to download the data to floppy disk. Total flying time which could be maintained on the hard disk is approximately 1.9 hours.

## 12. Ground Station Data Processing

### 12.1 Data Format Conversion

Currently available DARTH reproduction software allows the binary file, saved during data acquisition, to be output in a text file format. The user can select the required data channels to be output with each channel forming a column in the output file.

The output from the DARTH system consists of a large (approximately 500 kb) binary format file with the extension .DAT. This file is used as an input file to a purpose written program. This program (SPLTALLE.EXE) calls the existing DARTH reproduction software and breaks the input file into its 32 channels of information with the output saved in a text file with extension .0xx where xx is the channel number 1-32.

The program then searches each of these files and finds the maximum and minimum and the time at which these values occurred. This information is then output to a table in a text file with extension .RES.

The program continues by performing a Fast Fourier Transform (FFT) on each of the 32 channels. The text files with the exception of .030, .031, .032 and .098 are then deleted to save file space. These four files contain the accelerations in the three primary directions and timing information and are retained to allow the user to reconstruct the flight path at a later stage.

The user can then view the FFT of each of the channels immediately or quit the program. The FFT of each channel can be viewed at a later stage without having to run the analysis program again. The FFT information for each channel is contained in

a file with the extension .Rxx where xx is the channel information. These files are in binary format.

Within the viewing program the user can elect to see harmonics, sidebands, tag various points of interest or change the scale of the output to give more detail. Full instructions on each of these capabilities can be found in Appendix B.

After each manoeuvre is analysed the files remaining are as follows:

- .DAT - The original manoeuvre input file (binary);
- .030, .031, .032, .098 - The acceleration and timing files (text);
- .RES - The table of maximum and minimum values of each channel (text);
- .Rxx - The files containing the FFT information for each channel (binary).

Each of these files is resident in the same directory.

## 12.2 Data Analysis

Analysis will involve determining the frequencies and magnitudes of the applied stresses in the panels and the ESSS structure. To accomplish this, a Fast-Fourier-Transform (FFT) program and a turning-point analysis program, which are compatible with the DARTH output, have been written. These programs will allow:

- (a) determination of structural response frequencies;
- (b) correlation of panel strains with ESSS accelerations (in both the time and frequency domains);
- (c) correlation of panel strains with rotor frequencies (both main and tail rotors);
- (d) correlation of panel strains with flight conditions - i.e. which flight conditions generate the maximum strains.

Verification and some analysis of the data collected during the most recent flight will be performed before proceeding with the next flight. Because of the need to provide a review of the findings from the flight tests as soon as possible, detailed data analysis will be performed, to the maximum extent possible, as the flight tests proceed.

### 13. Progress and Future Actions

Flight tests are scheduled to commence during the week starting 6 February 1995. The flight tests will be conducted from the RAAF Edinburgh Base in Salisbury, South Australia.

There is a requirement for three AMRL staff to be on-board the aircraft, at least during the initial flight tests. These staff will consist of one to operate DARTH, one to check the transducers for correct operation (calibration, noise level etc.), and one structural specialist to observe the conduct of the flight tests and, if necessary, recommend changes to the flight conditions required for future flight tests. Fewer AMRL staff will be required on-board after system operation has been validated. A fourth member of AMRL staff will be located at the Edinburgh Base and will perform detailed ground station analysis of the recorded data.

"Shake-down" flights will be conducted before the actual test flights to check the instrumentation system. According to Sec. 5 there will be between eight and twelve aircraft configurations to test fly. Allowing one day for each aircraft configuration test (i.e. actual flight time plus subsequent data analysis) means that eight to twelve flying days will be required for the conduct of the data acquisition phase of the flight test program. With allowance for initial "shake-down" flights it is expected that the flight test program will run for about three weeks.

The flight tests should provide:

- (a) Strains in the FS295/FS308 inner panel and the ESSS.
- (b) Correlation of these strains with flight conditions.
- (c) Accelerations experienced by the ESSS.
- (d) Correlation of these accelerations with flight conditions.
- (e) Enough information to determine if the ESSS is responsible for driving the crack growth.
- (f) The flight conditions that are most fatigue damaging for the panel.
- (g) Enough data to allow the ARA to better manage the Black Hawk fleet in respect of the panel cracking problem.
- (h) Data which will be invaluable in future work on the Black Hawk.

Initial results will be available within one month of the completion of the flight tests. If nothing untoward is discovered in the flight test data, then final results can be expected three months after completion of the flight tests.

## 14. Concluding Remarks

- (a) To reduce the timescale for AMRL to prepare the Black Hawk for flight tests, it has been necessary to bring together a team of many skilled staff from various fields.
- (b) Problems were experienced with strain gauge placement on the ESSS struts. The best position for the gauges would have been midway along each strut. However, an aerodynamic fairing around each strut prevented access to almost all the strut. Various gauge positions were tried (on the strut end lugs and on the parts of the strut that were not covered by the fairing), but the results were not satisfactory. Eventually, part of the fairing assembly was removed and a gauge placed as far up the strut as possible. This position provided satisfactory results.
- (c) A delay in obtaining a set of serviceable struts resulted in an associated delay in completing the flight test instrumentation. However all the instrumentation and calibration for a suitable set of four struts was completed on 2 February 1995.
- (d) The installation (minus the ESSS) was successfully checked and recordings made during a ground run with the rotors turning on the AMRL helipad on 17 January. The aircraft returned to ARDU (without the ESSS) on 18 January 1995. The ESSS including the struts was returned to ARDU on 8 February 1995. Flight testing will commence at the RAAF Base Edinburgh on 7 February 1995 (initially without the ESSS installed) and is scheduled to last until about the 24 February 1995.

## Acknowledgments

The authors wish to thank the many AMRL staff who contributed to the preparation of the Black Hawk helicopter for flight tests. In particular the following contributions are gratefully acknowledged:

- Messrs Barry Ashcroft, Noel Hall, Rob Sebire, and Dave Smith for installing and wiring the strain gauges and accelerometers.
- Ms Sylvia Gonzalez for producing electrical circuit diagrams for the installation.
- Messrs Peter Smith and Steve Van Der Velden for preparation of the instrumentation system.

- Mr Michael Konak for analysing and rectifying problems with the DARTH amplifiers and filters.
- Messrs Chris Knight and Gareth Coco for producing the FFT analysis program.
- Messrs Carlos Rey, Chris Niessen, and Fred Harris for running the test machine and providing advice during the strut calibration procedures.
- Messrs Khan Sharp, Stephen Lamb, Noel Goldsmith and Howard Morton for undertaking detailed NDI of the ESSS struts and the fuselage panels.
- Mr Bob Jackson for coordinating the site arrangements for landing and parking of the Black Hawk helicopter, for coordinating visits of AMRL and other staff to the helicopter so as to ensure that the work program proceeded without interference, and for other liaison activities.
- Messrs Peter Mathews, Jonsun Shumoail, Michael Borg and Geoff Peterson for moving the Black Hawk to and from the helipad and for assisting the RAAF personnel during removal and installation of the main rotor blades.
- Dr Tom Ryall, Mr Dave Rowlands, and Ms Petra Cox for providing their FAST thermal strain imaging system to identify reasonable positions for strain gauges on the ESSS support struts and, as well, Mr Rowlands for providing photographic assistance.

## References

1. Army LM Squadron Minute to AMRL, Army LMS/4080/A25/109 Pt 1 (10), **Development Test and Evaluation Task Request**, 11 November 1994.
2. **AMRL Proposal for Meeting DT&E Requirement for S-70A-9 Black Hawk Inner Fuselage Panel Cracking Investigation**, distributed under cover of AMRL M2/998 Minute of 21 November 1994.
3. Sikorsky Engineering Report, SER 70742, **Structural Analysis of UH-60A Mid-Fuselage**, 15 June 1983.
4. AMRL M2/998 Minute of 17 June 1993.

Table 1: Summary of Cracked Panels for 5 Aviation Regiment (Townsville) Aircraft (as at 5/8/94)

Crack locations are indicated by an 'x' in the 'Panel Schema' column

A '.' in the aircraft tail number columns indicates that the aircraft has a crack at that point

Bead	Panel Schema	Aircraft Tail Number													Total	
		102	104	106	107	109	110	112	202	203	204	210	212	221		
1	[REDACTED]															
2	[REDACTED] x		.	.					.							3
3	[REDACTED] x	.	.	.						.	.					5
4	[REDACTED] x	.	.	.				.		.						5
5	[REDACTED] x	.	.	.	.	.	.	.	.	.	.	.	.	.	.	12
6	[REDACTED] x		.	.												2
7	[REDACTED] x	.	.	.	.		.	.	.	.	.			.		10
8	[REDACTED] x	.	.	.	.		.	.	.	.	.					9
9	[REDACTED] x		.	.	.				.		.					4
10	[REDACTED] x		.	.	.				.		.					3
11	[REDACTED]		.	.					.							3
12	[REDACTED]		.	.					.							3
13	[REDACTED]		.	.					.							3
14	[REDACTED]		.	.					.							3
15	[REDACTED]		.	.					.							3
	Total	6	13	12	4	1	3	4	7	4	6	1	1	2	64	

## Appendix A

### Data Acquisition Control Program for DARTH

#### 1. Data Acquisition Program

DARTH has a single menu-based program DARTHACQ that controls data acquisition. It is used in conjunction with DARTHSET, which allows the user to modify the gains, cutoff frequencies and DC offsets of DARTH's associated analog signal conditioners.

The DARTHACQ control program provides facilities to configure channels, save and load set-up configurations to and from disk files, examine current channel readings and, most importantly, record acquired channel data in a disk file until stopped by the user or available memory size.

The keyboard and screen interface provide the user with access to all the DARTHACQ commands. All available commands (Table 1) are displayed in a menu line on the screen and are selected by typing the first letter of the command name. DARTHACQ will then prompt the user for any information required, such as channel identification, and then complete the command. Context-sensitive help messages are provided when the function key F1 is pressed. The screen operates in 640 by 200 dot graphics mode. Two character font sizes and reverse video are used to compensate for the lack of colour on the display.

*Table 1: DARTHACQ commands*

Command	Brief Explanation
Analogue	Display the Analogue input channel configuration screen
Calibrate	Display the continuously updated tabulated list of current channel readings
Digital	Display the Digital and Synchro channel configuration screen
Exit	Exit from DARTHACQ to the DOS prompt
Load	Load a set-up file to configure all the data acquisition channels
Modify	Modify the configuration of a single channel or group of channels
Plot	Display a continuously updated plot of a specific input channel
Run	Start recording data according to the current channel set-up. Note that this will continue until CTRL and E are pressed on the keyboard.
Save	Save a set-up file that records the current configuration of channels

## 1.1 Set-up Files

DARTHACQ is normally configured by loading a set-up file. All set-up files reside in the SET sub-directory on the same drive as the data files. The set-up file, which may be created using the DARTHACQ SAVE command, consists of many lines of ASCII characters with each line being allocated specific information. Analogue input channels are detailed first as channels 1 to 32. Then follow digital input and output channels, analogue output channels and finally the synchro channels.

The sequence of the lines of information common to all channels is:

- three character identification
- description of the function or transducer assigned to the channel
- sample rate selected for that channel
- calibration offset
- calibration coefficient
- calibration squared coefficient

The set-up file for a particular trial can be automatically loaded when DARTHACQ is run.

## 1.2 Data Files

Data files, produced by DARTHACQ, are placed in the DATA sub-directory on the hard disk of the PC following automatic transfer from the RAM disk at completion of every data recording run. At the commencement of a run DARTHACQ interrogates and writes the DARTH hardware and software settings to a header file on the RAM disk. The initial part of the header file is almost a direct copy of the set-up file format, except that the first line is used to identify which version of DARTHACQ wrote the file. Then it sequentially appends binary data from the selected channels to that file. When the run is complete DARTHACQ copies the header plus data to a data file on the hard disk.

Typically the data files are transferred from the hard disk to a floppy disk and taken to another computer for post-processing and analysis.

## 1.3 Automatic Data File Naming

The data file may be given a computer-generated default file name when the keyboard is used to control DARTH. This default file name is in the form of day / month / hour / minute with a '.dat' extension. The file name then represents the time that the run started; not the time that the data were automatically transferred from RAM disk to the hard disk at completion of the run. Users can allocate a different file name at the time of recording to fit in with their particular naming convention.

An example of a default file name is 23101632.dat. This corresponds to the 23<sup>rd</sup> day of the 10<sup>th</sup> month (October) at 1632 hours (32 minutes past 4 PM). The time and date are derived by the Disk Operating System (DOS) from the PC clock.

#### 1.4 Real Time Display of Selected Channels

DARTHACQ can plot single channel data on the DARTH PC screen when a data file is not being recorded. It also can display a continuously updated list of channel readings. This list may be a display of raw signal values in hexadecimal units, signed decimal readings or preassigned engineering units.

#### 1.5 Scaling and Linearising Coefficients

The 'Modify' menu command allows the user to enter scaling coefficients for each channel to convert the raw data count from the ADC to a corresponding direct reading of voltage applied to the input of the ADC or, alternatively, by taking account of the channel gain, a direct reading of the analogue input signal in appropriate engineering units.

Data used for the quick-look display may be linearised through the use of a quadratic equation of the form:

$$Ad^2 + Bd + C$$

Where:

A, B and C are coefficients derived from channel calibration  
(entered by user in scientific notation)

d is the raw count value produced by the ADC within the range of  $\pm 2048$  units

The default coefficient values for the analogue channels, to convert the raw count data to signed decimal values which are then optionally displayed within a range of  $\pm 5$  volts, are:

$$A = 0 \quad B = 0.002441406 \quad (2.441406 \times 10^{-3}) \quad C = 0$$

Alternatively, with correctly chosen coefficients, any channel can be scaled for display in appropriate engineering units. For example, use of the 'calibrate' menu command provides:

- The first press of the 'C' key produces a display, scaled in hexadecimal code, of the channel signal voltage at the input of the ADC.
- The second press of the 'C' key produces a display, scaled in signed decimal volts, of the channel signal voltage at the input of the ADC.
- The third press of the 'C' key produces a display, scaled in appropriate engineering units, of the channel signal voltage at the input stage and allows for the channel sensitivity.

## 2.0 Operating Tutorial

During preparations for a trial the various set-up files will be created which can then be automatically loaded at run time. The two set-up files created are from DARTHSET, which holds all the gain, filter cutoff frequency, sampling rate and DC offset information for each of the analog channels. This is usually run either from a batch file previously created or automatically when power is first applied to the PC. The second set-up file, created by DARTHACQ, contains all the channel description information and factors to convert from raw binary data to engineering units. This file is normally loaded automatically when the DARTHACQ program is executed.

When the PC is powered up a batch file is used to enable DARTHSET to initialise its hardware, via the appropriate DARTHSET file, followed by execution of the DARTHACQ program, together with the automatic loading of its set-up file.

Once DARTHACQ is running the user is able to issue commands to the program, as indicated in Table 1 above (Sec. 1.0).

1. To acquire and record data the user simply presses the R (Run) key, then enters the name of the file the data are to be saved in (or ENTER to accept the default date-time-stamp name).
2. After a second has elapsed the computer will start to acquire data, storing the binary data on RAM disk. To complete the acquisition the user presses the **CTRL and E keys simultaneously**, after which the data file will be moved from the RAM disk to the hard disk. Steps 1 and 2 can be repeated indefinitely, until the hard disk is filled.

## Appendix B

### Instructions for Ground Station Data Processing

1. Copy contents of the 3.5 inch disk to a directory on the hard drive of the parent machine.
2. Copy data file (FNAME.DAT) of particular manoeuvre to the same directory.
3. At the command line type SPLTALL and press return.
4. The program will prompt for the name of the manoeuvre file. Type FNAME.DAT including any paths.
5. The program will proceed to split the data file into the 32 channels. This is quite a long process and may take a minute or so.
6. This process will create 32 additional binary files with the extension .Rxx where xx is the channel number ( eg channel 1 is .R01 and channel 23 is .R23).
7. The process will also create .RES file which is a text file containing the maximum and minimum of each channel and the time at which it occurs.
8. Four additional text files are retained by the program. These contain centre of gravity acceleration information and timing information.
9. At this stage the user should check that the program is processing port or starboard information or that an error has not occurred (according to the printout on the screen).
10. The program will prompt for a channel number to view. To view channel 10 (say) type 10 and press return.
11. The FFT for channel 10 will be displayed. The cursor keys move a prompt across the plot and below the plot are the corresponding frequency and amplitude.
12. CTRL-cursor keys moves the prompt across the screen more quickly.
13. Pressing H whilst on this screen will cause harmonics to appear and these also can be moved by the cursor.
14. Pressing S will cause sidebands to be generated from that point when the cursor is subsequently moved.
15. Pressing N will remove sidebands and harmonics from the plot.
16. Pressing T whilst on this screen will cause the particular point to be tagged with its corresponding frequency and amplitude.
17. To change the scale of the y axis press + or - to double or halve the scale respectively or A to autoscale the plot. Autoscale will optimise the screen display. F will return the scale to original.
18. To view another channel press the up or down arrows to view the next or previous channel. Pressing Q at this stage will end the program.

19. Once the file has been broken into its components it is possible to view a channel without splitting the original file. To do this type FFT-VIEW. This program will then prompt for a channel to view. Type FNAME.Rxx (where xx is the channel name as before). The familiar graphic output with the same commands will then be seen.
20. The commands within the graphic screen are the same as previously quoted.
21. Pressing ESC on this screen will exit from the program.

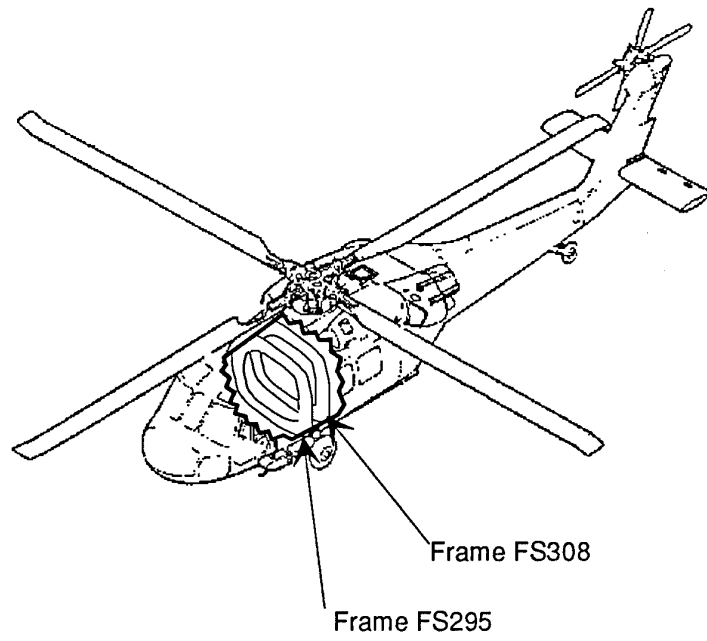

Figure 1: Location of Frames FS295 and FS308

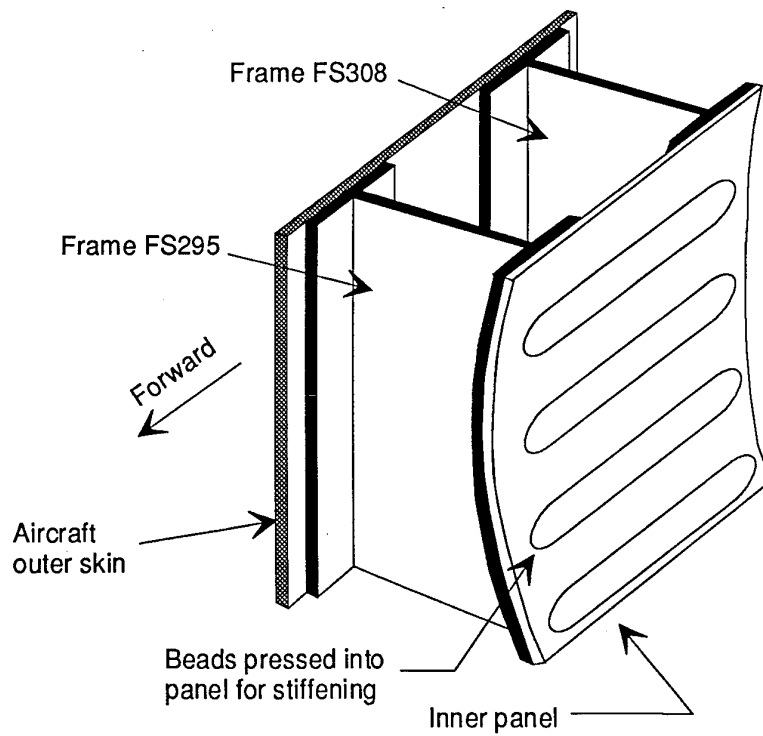

Figure 2: Close-up view of the panel

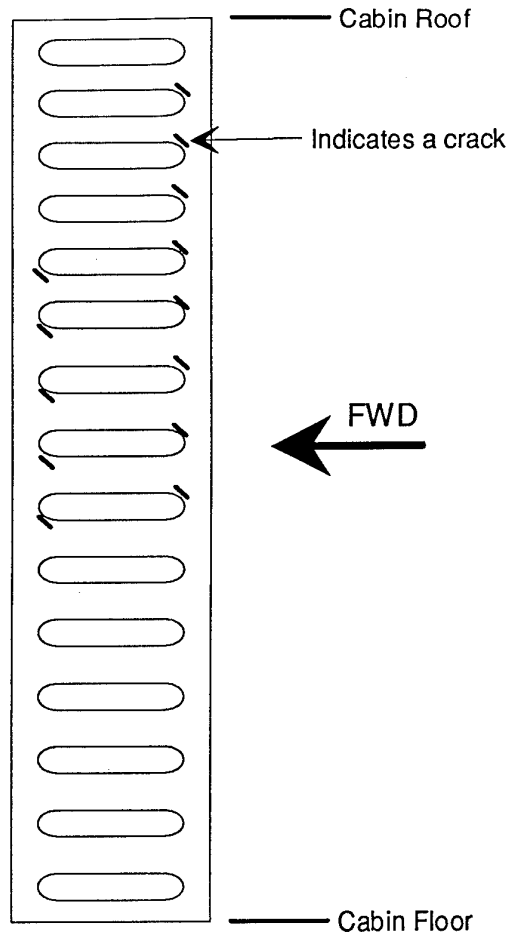

Figure 3: Cracks in aircraft A25-104



*(a) Just before landing on helipad*



*(b) Sitting on helipad*

*Figure 4: Black Hawk helicopter landing on AMRL helipad on 30 November 1994*

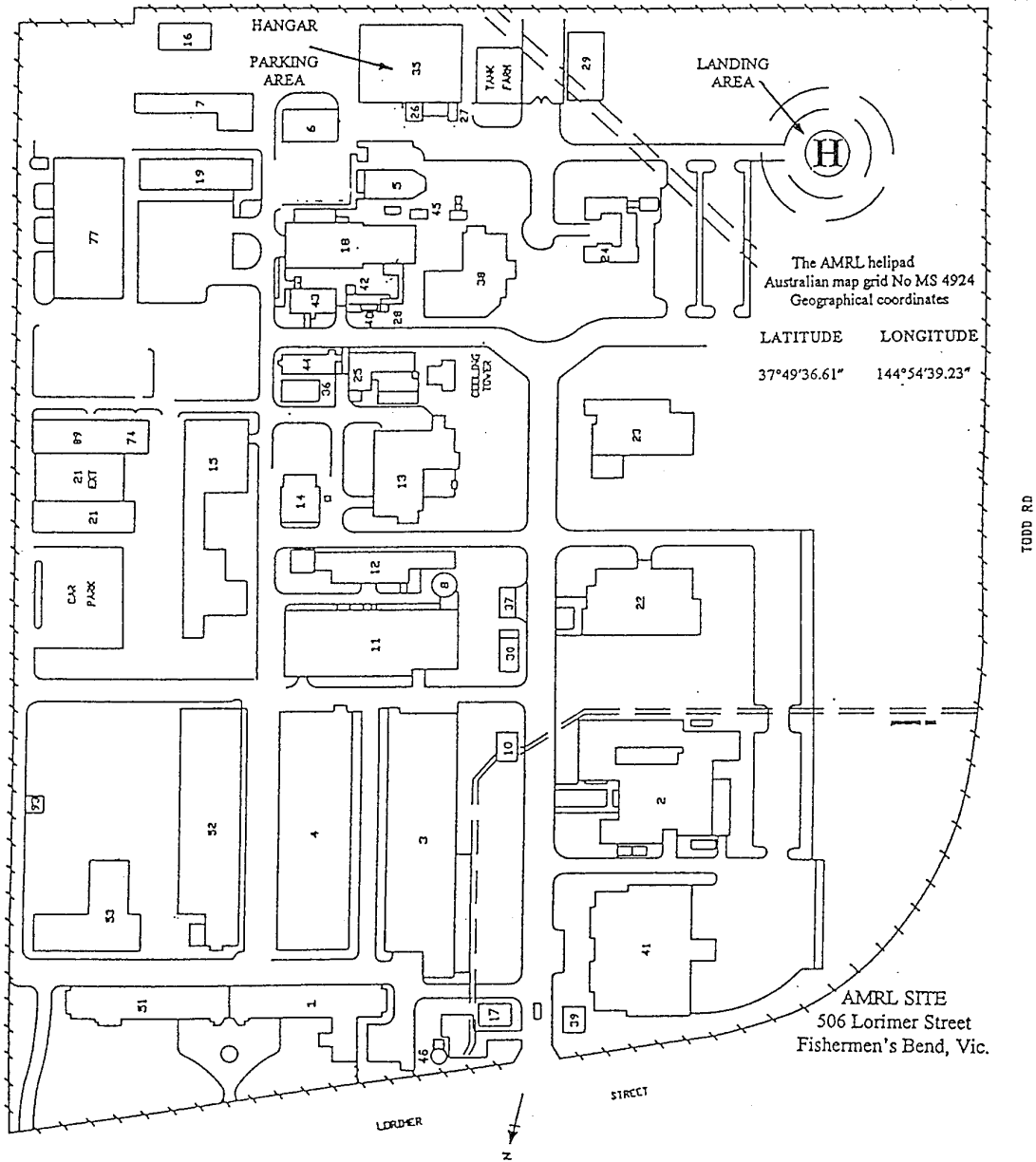

Figure 5: AMRL Site Plan showing aircraft landing and parking locations

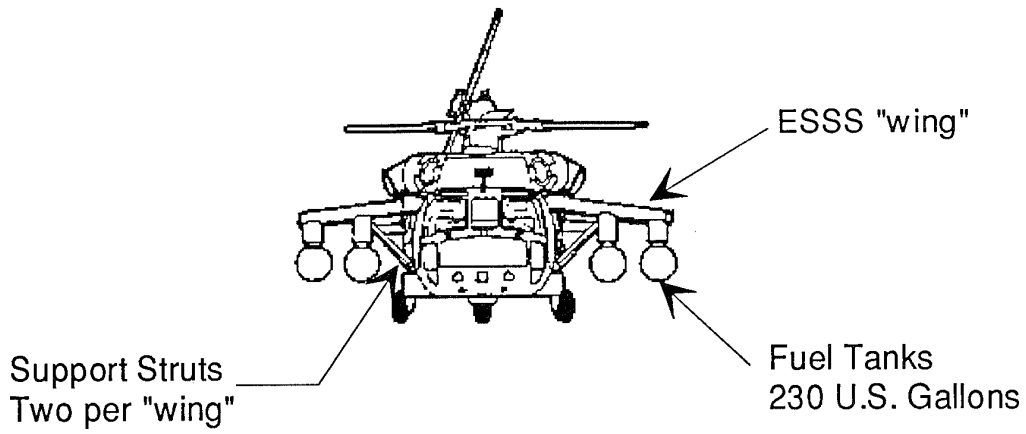

Figure 6: Front view of a Black Hawk showing the ESSS

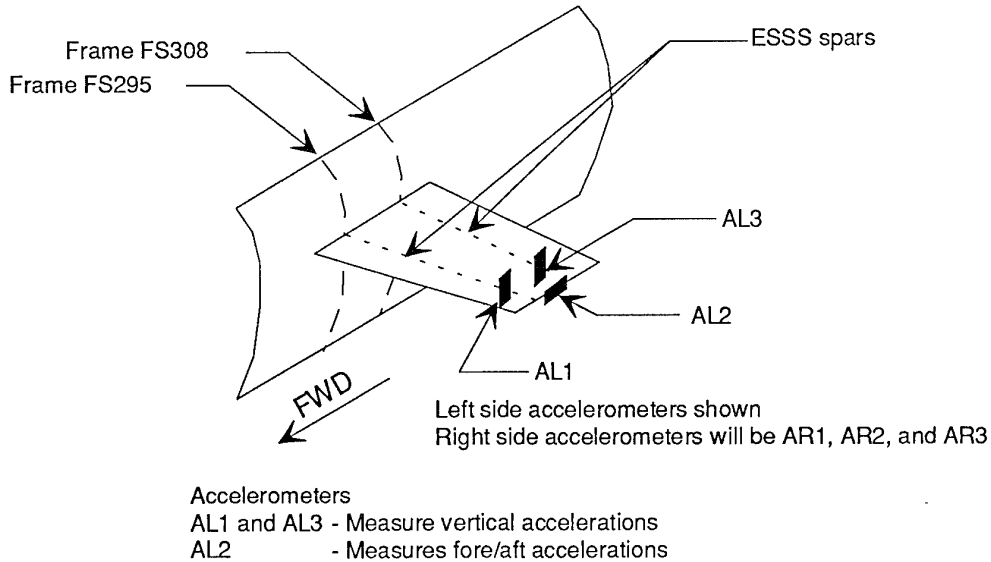
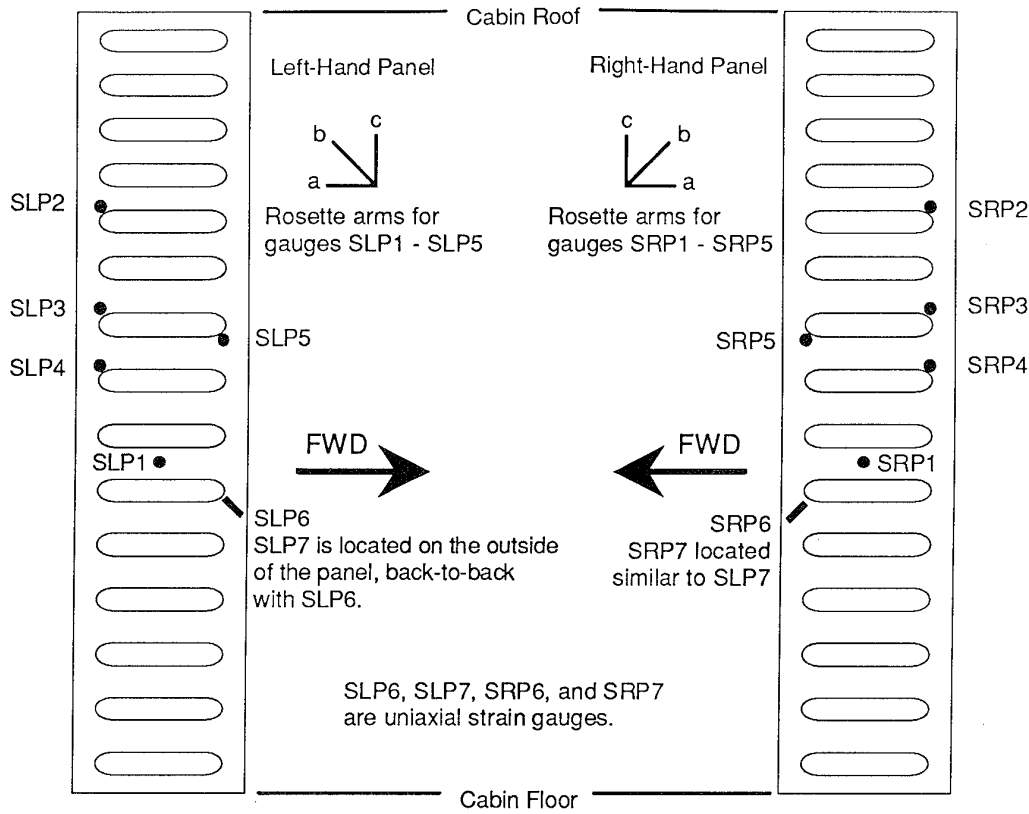
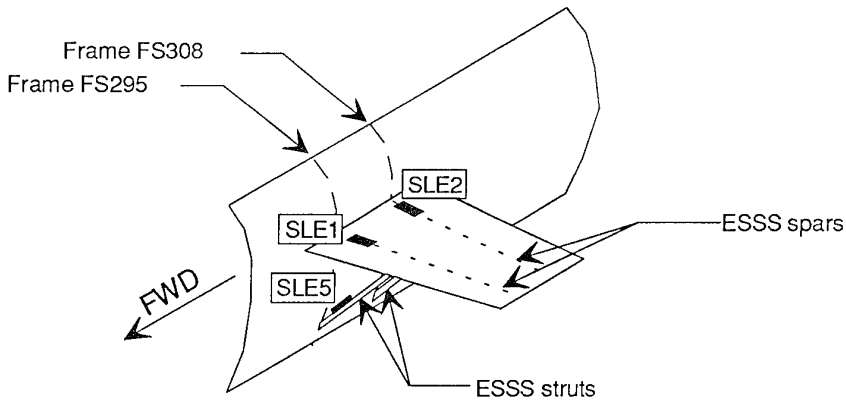

Figure 7: Accelerometer locations



INTERNAL PANEL STRAIN GAUGES



- SLE1 and SLE2 - Located above the ESSS spars on the upper surface of the "wing"
- SLE3 - Located on the lower surface of the "wing", under SLE1
- SLE4 - Located on the lower surface of the "wing", under SLE2
- SLE5 - Located on the forward strut tube, 110 mm from lower end of composite tube
- SLE6 - Located on the rear strut as per SLE5, but 140 mm from lower end

Left-hand side strain gauges shown. Right-hand side strain gauges be located in equivalent positions and are known as SRE1, SRE2, ..., SRE6.

ESSS STRAIN GAUGES

Figure 8: Strain gauge locations

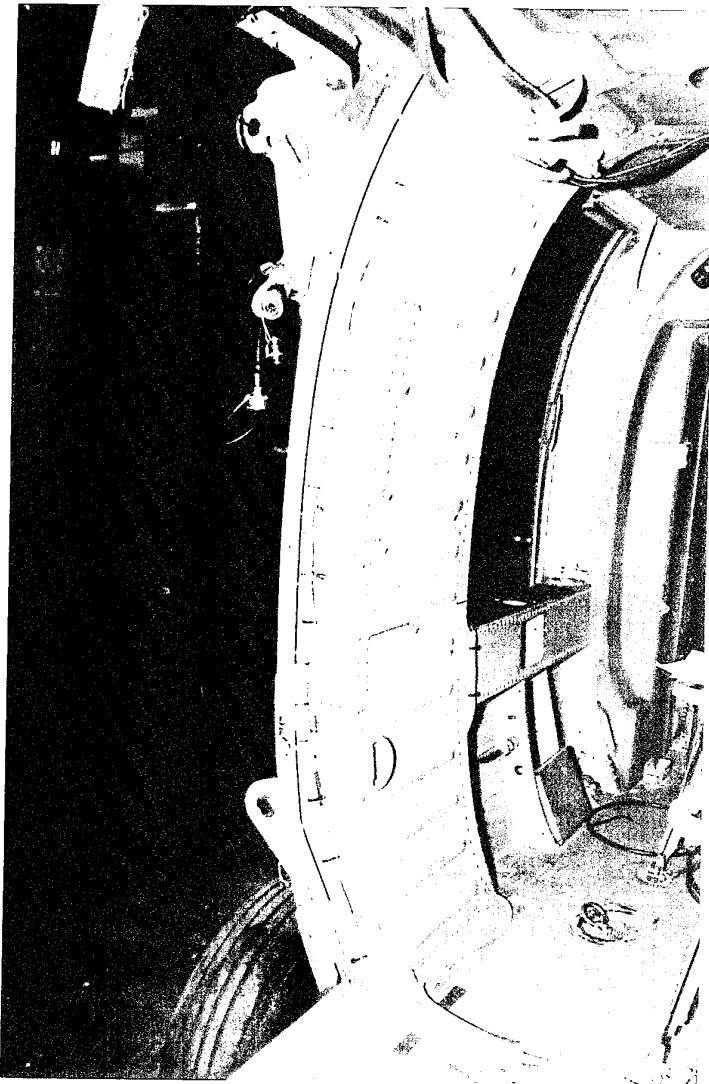

*Figure 9: Left side fuselage panel showing strain gauge connections*

*This page intentionally left blank*

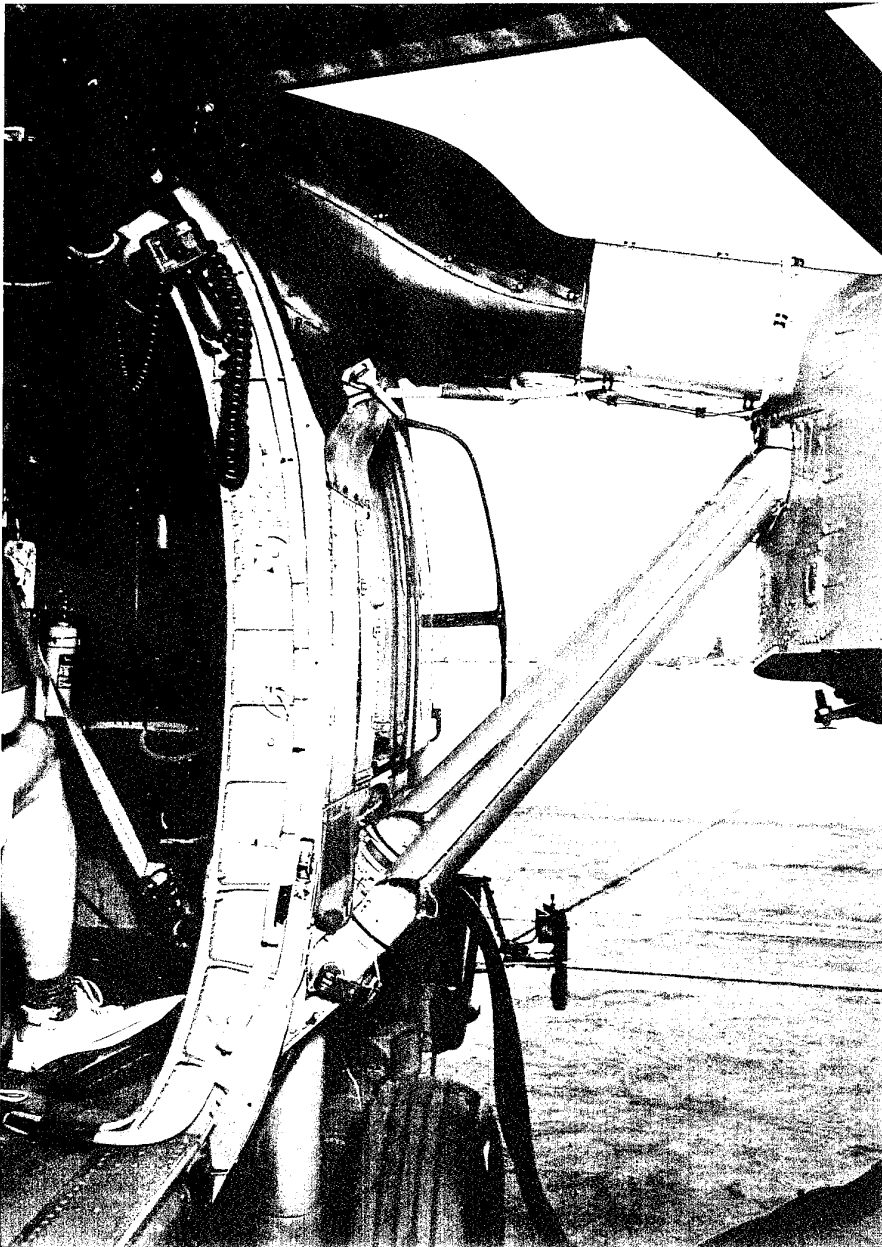

*Figure 10: ESSS on aircraft showing some of the strain gauge and accelerometer looms*

*This page intentionally left blank*

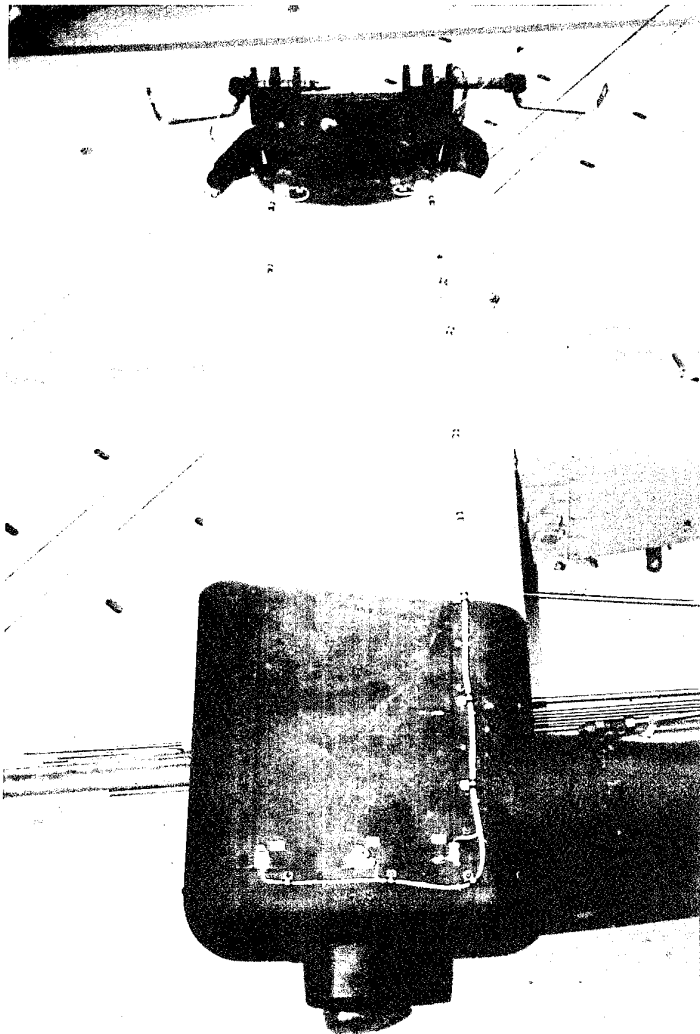

*Figure 11: LH ESSS wing showing accelerometer connections (outboard) and strain gauge connections (inboard)*

*This page intentionally left blank*

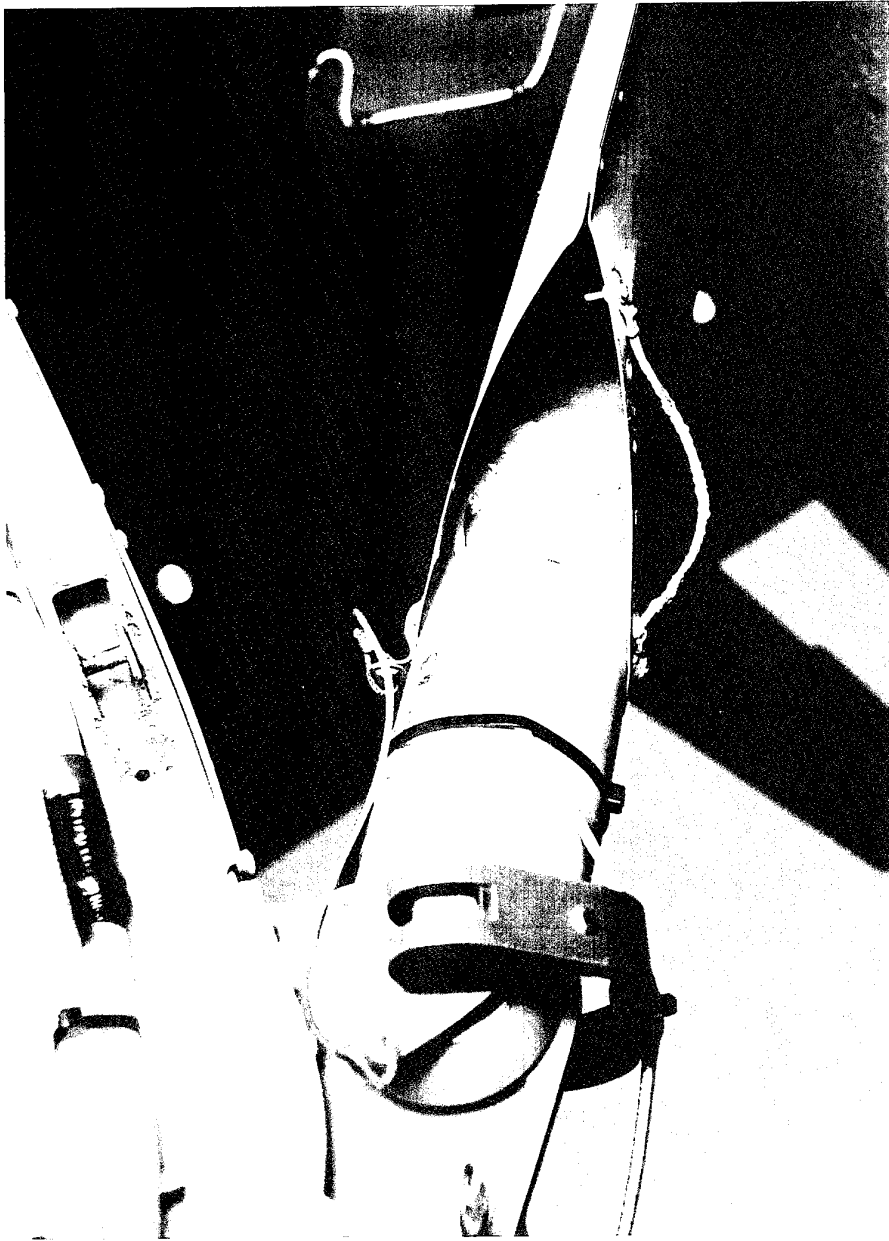

*Figure 12: ESSS strut with end fairing removed and showing strain gauge connections*

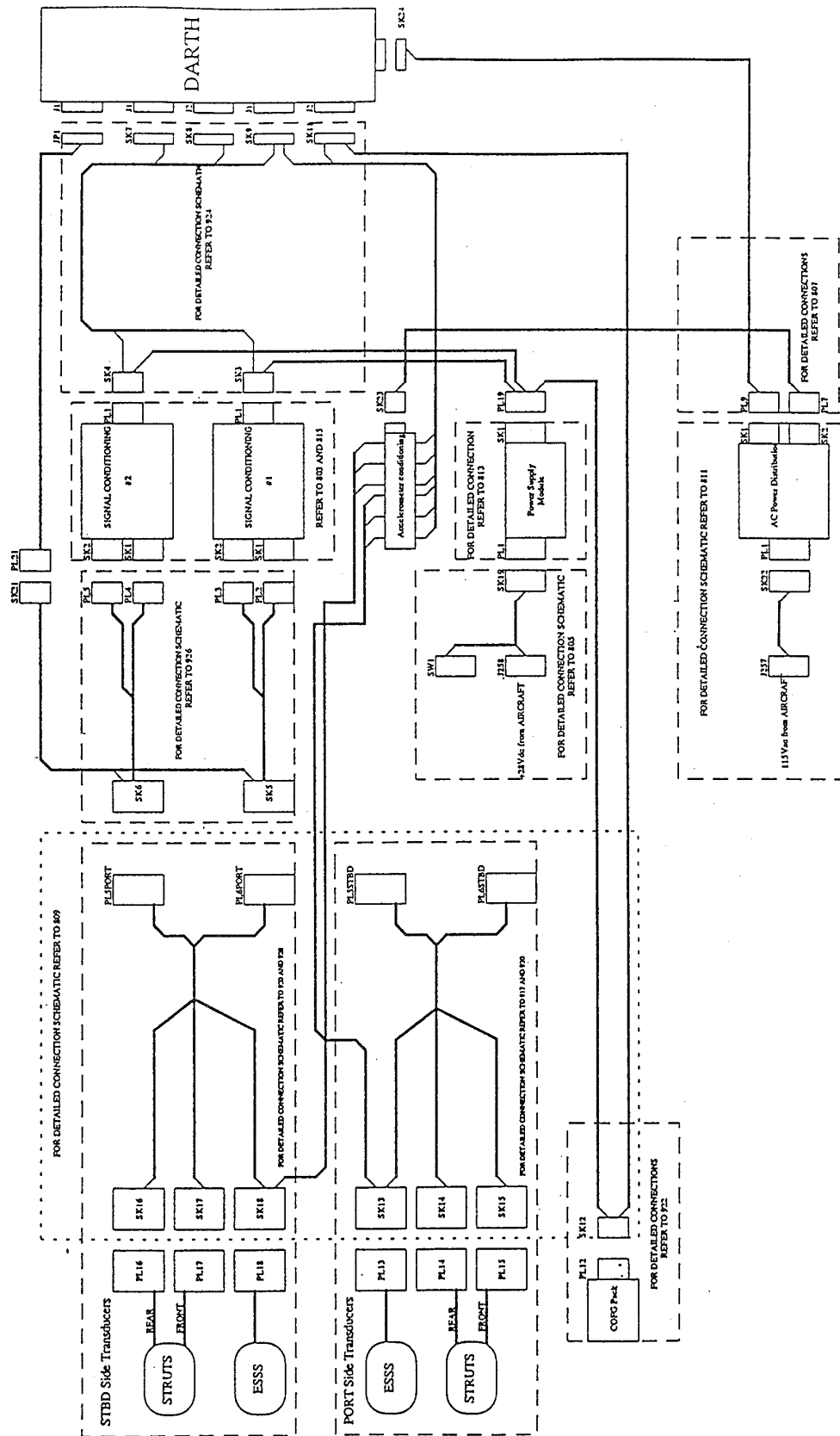
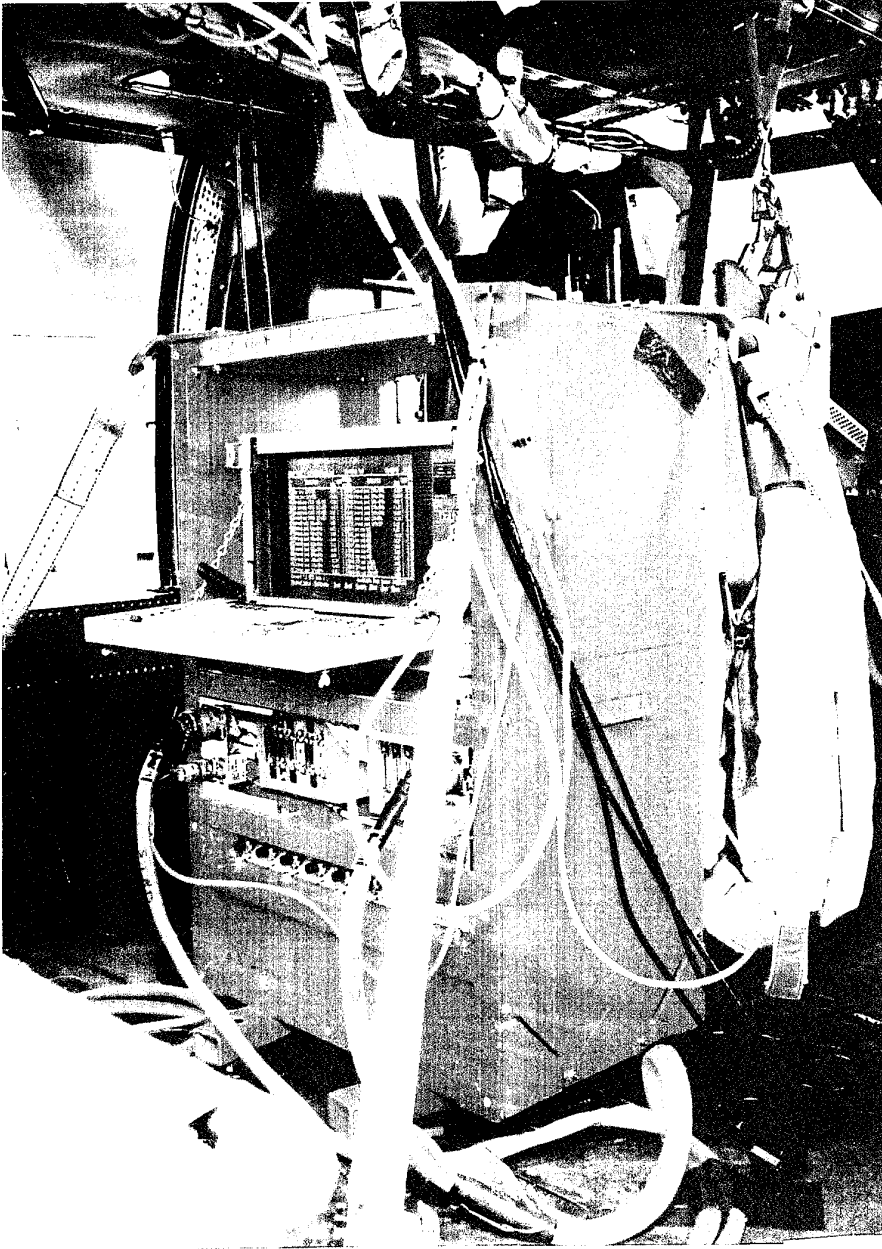
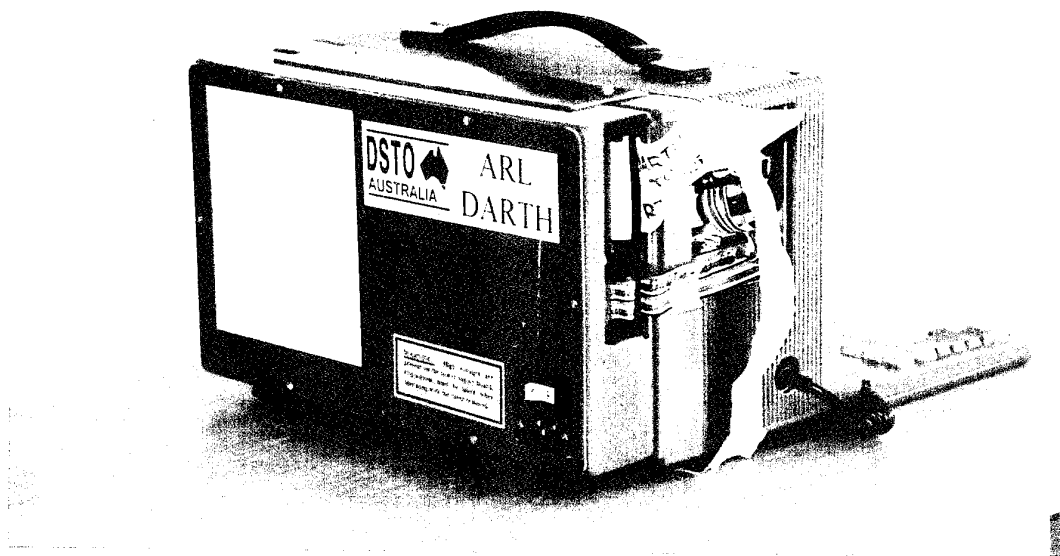

Figure 13: Block schema of instrumentation system showing sub-system interconnections



*Figure 14: Instrumentation mounted on floor near centre of gravity*

*This page intentionally left blank*



*Figure 15: DARTH computer removed from rack*

DSTO-TN-0004

Preparation of S-70A-9 Black Hawk Helicopter for Flight Tests to Investigate Cause of  
Cracking of Inner Fuselage Panel

D.C. Lombardo, A.K. Patterson, P. Ferrarotto, S.A. Dutton, I.G. Powlesland  
and K.F. Fraser

**DISTRIBUTION**

**AUSTRALIA**

Defence Organisation

Defence Central

Chief Defence Scientist  
FAS, Science Policy  
Counsellor Defence Science, London (Doc Data Sheet only)  
Counsellor Defence Science, Washington (Doc Data Sheet only)  
Senior Defence Scientific Adviser (Doc Data Sheet only)  
Scientific Advisor Policy and Command (Doc Data Sheet only)

DSTO

OIC TRS, Defence Central Library  
Document Exchange Centre, DSTIC (8 copies)  
Defence Intelligence Organisation  
Library, Defence Signals Directorate (Doc Data Sheet Only)

Science Policy Division

Air Force Scientific Adviser  
Scientific Adviser - Army  
Staff Officer Science: Army HQ1 Divn.  
Staff Officer Science: RAAF Base Townsville  
Navy Scientific Adviser (3 copies Doc Data Sheet only)

Aeronautical and Maritime Research Laboratory

Library, Fishermens Bend  
Library, Maribyrnong  
Director  
Chief of Airframes and Engines Division  
Research Leader Structural Dynamics  
TTCP HTP-8 Australian National Leader  
R.C. Adams  
J.M. Grandage  
C.N. King  
C.G. Knight  
L. Krake  
L. Molent  
Authors: D.C. Lombardo  
A.K. Patterson  
P. Ferrarotto  
S.A. Dutton  
I.G. Powlesland  
K.F. Fraser

Electronics and Surveillance Research Laboratory

Director  
Library

Air Force

Army Aircraft Logistics Management Squadron:

Chief Engineer  
Utility Helicopter Flight Commander  
Black Hawk Logistics Manager

Aircraft Research and Development Unit:

WGCDR P. Campbell (CO Engineering Squadron)

Mr K. McCleod

SQNLDR D. Boorman

MAJ D. Fawcett

Director Technical Airworthiness

CAPT N. Skuja, ASI2B, Army Aircraft Structural Integrity

Director Army Aircraft Projects

Technical Liaison Officer U.S. Army ATCOM (St Louis)

Technical Liaison Officer Warner Robbins Air Force Base (Georgia)

Army

Director of Aviation (Army)

Commanding Officer Maintenance Engineering Agency

Navy

Director Aircraft Engineering

Superintendent Aircraft Logistics

**OTHER**

United Technologies Sikorsky Aircraft

T.J. Armond, S-70 ILS manager Worldwide Customer Services

U.S. Army

F.H. Immen, Head Engineering Structures and Materials Divn, U.S.  
Army ATCOM (St Louis, Missouri)

W.Elber, Director Vehicle Structures Directorate, NASA Langley  
Research Center (Hampton, Virginia)

D.E. Good, Chief Air Vehicles Structures Division, Aviation Applied  
Technology Directorate (Ft Eustis, Virginia)

U.S. Navy

G.Barndt, Structures Branch, Naval Air Systems Command (Washington DC)

Chadwick Helmuth Company Inc.

L.L. Dobrin, Director of Business Development, On-Board Systems

VMS Industries Pty Ltd

R. Mulder, Manager

SPARES (10 copies)

TOTAL (69 copies)

## DOCUMENT CONTROL DATA

1a. AR NUMBER AR-009-205	1b. ESTABLISHMENT NUMBER DSTO-TN-0004	2. DOCUMENT DATE FEBRUARY 1995	3. TASK NUMBER AIR 94/371				
4. TITLE  PREPARATION OF S-70A-9 BLACK HAWK HELICOPTER FOR FLIGHT TESTS TO INVESTIGATE CAUSE OF CRACKING OF INNER FUSELAGE PANEL		5. SECURITY CLASSIFICATION (PLACE APPROPRIATE CLASSIFICATION IN BOX(S) I.E. SECRET (S), CONF. (C) RESTRICTED (R), LIMITED (L), UNCLASSIFIED (U)).					
		<table border="1"> <tr> <td>U</td> <td>U</td> <td>U</td> </tr> <tr> <td>DOCUMENT</td> <td>TITLE</td> <td>ABSTRACT</td> </tr> </table>		U	U	U	DOCUMENT
U	U	U					
DOCUMENT	TITLE	ABSTRACT					
8. AUTHOR(S) D.C. LOMBARDO, A.K. PATTERSON P. FERRAROTTO, S.A. DUTTON, I.G. POWLESLAND AND K.F. FRASER		9. DOWNGRADING/DELIMITING INSTRUCTIONS  Not applicable.					
10. CORPORATE AUTHOR AND ADDRESS  AERONAUTICAL AND MARITIME RESEARCH LABORATORY AIRFRAMES AND ENGINES DIVISION PO BOX 4331 MELBOURNE VIC 3001 AUSTRALIA		11. OFFICE/POSITION RESPONSIBLE FOR:  RAAF-LC  SPONSOR _____ SECURITY _____ DOWNGRADING _____ APPROVAL _____ CAED					
12. SECONDARY DISTRIBUTION (OF THIS DOCUMENT)  Approved for public release.  OVERSEAS ENQUIRIES OUTSIDE STATED LIMITATIONS SHOULD BE REFERRED THROUGH DSTIC, ADMINISTRATIVE SERVICES BRANCH, DEPARTMENT OF DEFENCE, ANZAC PARK WEST OFFICES, ACT 2601							
13a. THIS DOCUMENT MAY BE ANNOUNCED IN CATALOGUES AND AWARENESS SERVICES AVAILABLE TO . . .  No limitations.							
14. DESCRIPTORS UH-60A helicopters Fuselages Aircraft panels		15. DISCAT SUBJECT CATEGORIES 010301					
16. ABSTRACT <i>An Australian Army Black Hawk helicopter has been fitted with suitable flight test instrumentation at the Aeronautical and Maritime Research Laboratory to enable an investigation of the cause of cracking in an internal fuselage skin panel. Nine accelerometer channels and 46 strain gauge channels have been provided. Reasons for the choice of measurement type and location are provided together with details of the measuring system installed. Plans for the conduct of suitable flight tests and for the valuation of the collected data are provided.</i>							

PAGE CLASSIFICATION  
UNCLASSIFIED

PRIVACY MARKING

THIS PAGE IS TO BE USED TO RECORD INFORMATION WHICH IS REQUIRED BY THE ESTABLISHMENT FOR ITS OWN USE BUT WHICH WILL NOT BE ADDED TO THE DISIS DATA UNLESS SPECIFICALLY REQUESTED.

16. ABSTRACT (CONT).

17. IMPRINT

**AERONAUTICAL AND MARITIME RESEARCH LABORATORY, MELBOURNE**

18. DOCUMENT SERIES AND NUMBER

DSTO-TECHNICAL NOTE-0004

19. WA NUMBER

A 20050

20. TYPE OF REPORT AND PERIOD COVERED

21. COMPUTER PROGRAMS USED

22. ESTABLISHMENT FILE REF.(S)

M1/9/67

23. ADDITIONAL INFORMATION (AS REQUIRED)