

ARMY RESEARCH LABORATORY



# Flamespreading Processes in Ball Powder Propellants

Andrew L. Brant  
Joseph W. Colburn  
Carl R. Ruth  
U.S. ARMY RESEARCH LABORATORY

Dennis W. Worthington  
OLIN ORDNANCE

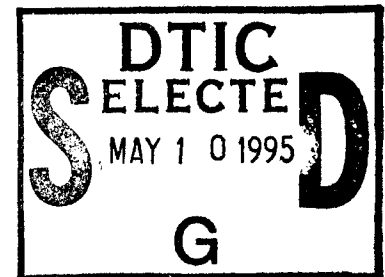

ARL-TR-731

April 1995

19950508 078

APPROVED FOR PUBLIC RELEASE; DISTRIBUTION IS UNLIMITED.

## **NOTICES**

**Destroy this report when it is no longer needed. DO NOT return it to the originator.**

**Additional copies of this report may be obtained from the National Technical Information Service, U.S. Department of Commerce, 5285 Port Royal Road, Springfield, VA 22161.**

**The findings of this report are not to be construed as an official Department of the Army position, unless so designated by other authorized documents.**

**The use of trade names or manufacturers' names in this report does not constitute endorsement of any commercial product.**

# REPORT DOCUMENTATION PAGE

Form Approved  
OMB No. 0704-0188

Public reporting burden for this collection of information is estimated to average 1 hour per response, including the time for reviewing instructions, searching existing data sources, gathering and maintaining the data needed, and completing and reviewing the collection of information. Send comments regarding this burden estimate or any other aspect of this collection of information, including suggestions for reducing this burden, to Washington Headquarters Services, Directorate for Information Operations and Reports, 1215 Jefferson Davis Highway, Suite 1204, Arlington, VA 22202-4302, and to the Office of Management and Budget, Paperwork Reduction Project (0704-0188), Washington, DC 20503.

1. AGENCY USE ONLY (Leave blank)	2. REPORT DATE <b>April 1995</b>	3. REPORT TYPE AND DATES COVERED <b>Final, January 1990–November 1990</b>
----------------------------------	-------------------------------------	--

4. TITLE AND SUBTITLE <b>Flamespreading Processes in Ball Powder Propellants</b>	5. FUNDING NUMBERS <b>PR: 1L162618AH80</b>
---	---

6. AUTHOR(S) <b>Andrew L. Brant, Joseph W. Colburn, Carl R. Ruth, and Dennis W. Worthington*</b>
---

7. PERFORMING ORGANIZATION NAME(S) AND ADDRESS(ES) <b>U.S. Army Research Laboratory ATTN: AMSRL-WT-PA Aberdeen Proving Ground, MD 21005-5066</b>	8. PERFORMING ORGANIZATION REPORT NUMBER <b>ARL-TR-731</b>
---	---

9. SPONSORING / MONITORING AGENCY NAME(S) AND ADDRESS(ES)	10. SPONSORING / MONITORING AGENCY REPORT NUMBER
---	--

11. SUPPLEMENTARY NOTES <b>*Olin Ordnance</b>
--

12a. DISTRIBUTION / AVAILABILITY STATEMENT <b>Approved for public release; distribution is unlimited.</b>	12b. DISTRIBUTION CODE
--	------------------------

13. ABSTRACT (Maximum 200 words)  <p><b>Ball powder propellants, loose and compacted, have been considered for use in recent years in tank and artillery applications. They are of interest due to the potential for high loading density, reduced temperature sensitivity, and improved performance through chemical/geometric progressivity control. However, there are several areas of concern, among them an uncontrolled deconsolidation process of compacted ball powder and a reduction in performance if the deterrent location is varied from the optimum.</b></p> <p><b>In order to address these concerns, a study was conducted by the U.S. Army Ballistic Research Laboratory and Olin Corporation to investigate the initial phase of the ballistic cycle with a 120-mm simulator. The simulator, employing a disposable plexiglass chamber, allowed direct viewing of the events occurring during the ignition and flamespreading portion of the interior ballistic cycle via high-speed cinematography. Pressures were measured at the ends and interior of the chamber with gages mounted in the case base, projectile fins, and projectile base. Shots were conducted with loose and compacted ball powder charges at several temperatures.</b></p>
--

14. SUBJECT TERMS <b>ball powder propellants, ignition studies, flamespreading, gun simulator, compacted charges, consolidation charges, dewatered propellants, propellant control</b>	15. NUMBER OF PAGES <b>24</b>
	16. PRICE CODE

17. SECURITY CLASSIFICATION OF REPORT <b>UNCLASSIFIED</b>	18. SECURITY CLASSIFICATION OF THIS PAGE <b>UNCLASSIFIED</b>	19. SECURITY CLASSIFICATION OF ABSTRACT <b>UNCLASSIFIED</b>	20. LIMITATION OF ABSTRACT <b>UL</b>
--	---	--	---

INTENTIONALLY LEFT BLANK.

TABLE OF CONTENTS

	<u>Page</u>
LIST OF FIGURES .....	v
ACKNOWLEDGMENTS .....	vi
1. INTRODUCTION .....	1
2. EXPERIMENTAL .....	1
3. EXPERIMENTAL DATA .....	4
3.1 Loose BALL POWDER Charge, 21°C .....	4
3.2 Compacted BALL POWDER Charge, 21°C .....	6
3.3 Compacted BALL POWDER Charge, -32°C .....	8
3.4 Compacted BALL POWDER Charge, 54°C .....	10
4. CONCLUDING REMARKS .....	11
5. REFERENCES .....	15
DISTRIBUTION LIST .....	17

Accession For	
NTIS CRA&I	<input checked="" type="checkbox"/>
DTIC TAB	<input type="checkbox"/>
Unannounced	<input type="checkbox"/>
Justification .....	
By .....	
Distribution /	
Availability Codes	
Dist	Avail and/or Special
A-1	

INTENTIONALLY LEFT BLANK.

LIST OF FIGURES

<u>Figure</u>	<u>Page</u>
1. Diagram of Interior Ballistic Simulator .....	2
2. Experimental Test Setup .....	2
3. BALL POWDER Propellant Base Grain .....	3
4. Loose BALL POWDER Propellant Charge .....	3
5. Compacted BALL POWDER Propellant Charge .....	4
6. Pressures and Radar Data, Loose BALL POWDER , 21°C .....	5
7. Schematic of Flamespread in Loose BALL POWDER , 21°C .....	6
8. Pressures and Radar Data, Compacted BALL POWDER , 21°C ...	7
9. Schematic of Flamespread in Compacted BALL POWDER , 21°C .	8
10. Pressures and Radar Data, Compacted BALL POWDER , -32°C ..	9
11. Schematic of Flamespread in Compacted BALL POWDER , -32°C.	10
12. Pressures and Radar Data, Compacted BALL POWDER , 54°C ...	11
13. Schematic of Flamespread in Compacted BALL POWDER , 54°C .	12

INTENTIONALLY LEFT BLANK.

## ACKNOWLEDGMENTS

The authors would like to thank James Bowen, John Hewitt, James Tuerk, and Dennis Meier for their assistance with the simulator setup and firings.

INTENTIONALLY LEFT BLANK.

## 1. INTRODUCTION

For some time, the Olin Corporation's research and development facility at St. Marks, Florida, and the Ballistic Research Laboratory (BRL), Aberdeen Proving Ground, MD,\* have been involved in an unfunded study investigating the potential of compacted BALL POWDER® propellants as a means of reducing propulsion system temperature sensitivity. Generally, as a propellant's temperature increases, chamber pressures and muzzle velocities increase, resulting in maximum performance only when firing at the hot temperature limit. Therefore, a desirable propellant should exhibit little change in burning characteristics over a wide temperature range (-45 to +65°C).

Olin has developed compacted BALL POWDER® charges in systems ranging from small caliber up to the 120-mm smooth bore tank gun that may partially meet this criterion. Their data, obtained using 20-mm and 30-mm compacted charges, indicated a substantial decrease in temperature sensitivity (Kruczynski 1991). As part of the unfunded research agreement with Olin and because of a lack of the necessary facilities at Olin to fire 120-mm compacted charges, the BRL undertook the investigation of the behavior of these charges in gun firings.

In the past, the BRL has extensively used large-caliber simulators to study the ignition and combustion processes of propellant charges (Chang and Rocchio 1988). Consequently, prior to the actual gun firings, a series of low-pressure simulator firings were undertaken to study the ignition and flamespread phenomena of both loose and compacted Olin charges. This report presents the results of these experiments.

## 2. EXPERIMENTAL APPARATUS AND CHARGE DESIGN

The apparatus designed to simulate a 120-mm round consisted of the case base of a real cartridge, a transparent acrylic tube containing propellant and an inert projectile, and the forcing cone section of a shortened gun barrel in which the front of the projectile was inserted. A cross-sectional view of the simulator is shown in Figure 1. The fixture was held together by a series of bolts and was mounted on a steel platform.

\*On 30 September 1992, the U.S. Army Ballistic Research Laboratory (BRL) was deactivated and subsequently became part of the U.S. Army Research Laboratory (ARL) on 1 October 1992.

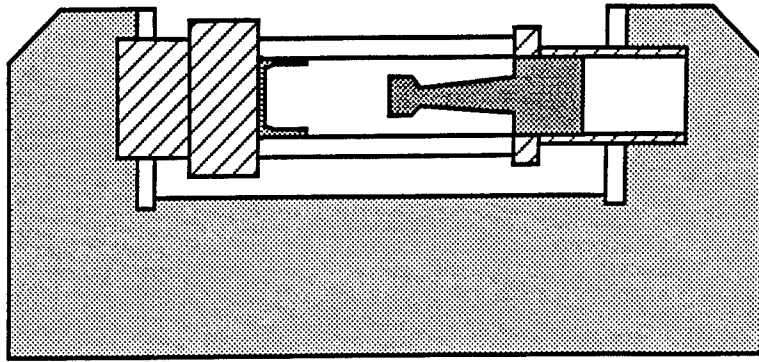

Figure 1. Diagram of Interior Ballistic Simulator

The simulator was generally capable of withstanding dynamic pressures up to approximately 15 MPa before rupturing. Pressure measurements were obtained using four PCB Model 113A23 gages. Two gages (P1,P2) were mounted in the breech, one gage (P3) was mounted in the rear of the fins, and one gage (P4) was mounted in the projectile afterbody near the front of the chamber. Photographic data was obtained at a framing rate of approximately 5,000 pictures per second using a 16-mm Hycam camera. A 35-GHz microwave interferometer was placed about 25 feet in front of the simulator to record projectile motion. The interferometer was protected from blast debris by a 1-inch-thick plexiglass shield and a steel trap designed to catch the projectile if it left the simulator. A schematic of the entire arrangement is shown in Figure 2.

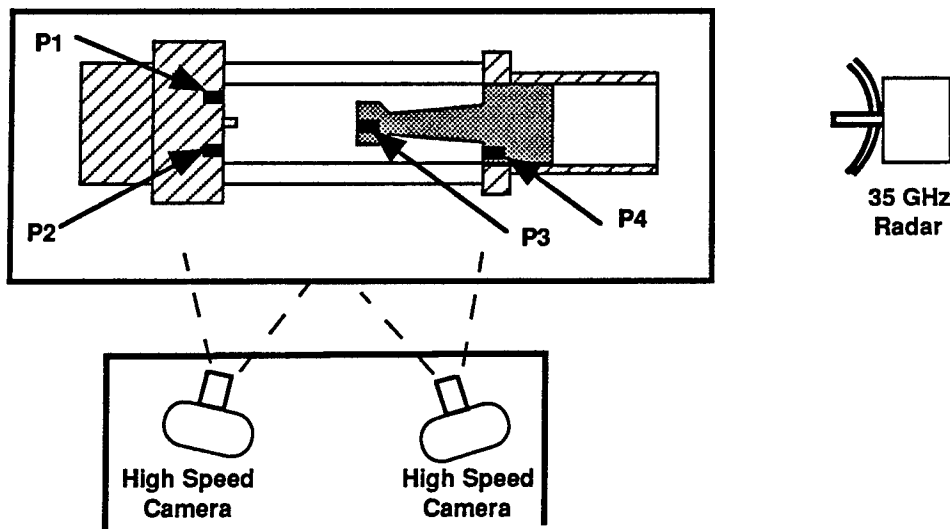

Figure 2. Experimental Test Setup

The propellant base grain for all the charges used was a deterred rolled BALL POWDER® propellant. Figure 3 shows a cross-sectional view of a sample grain along with plot of a typical deterrent gradient.

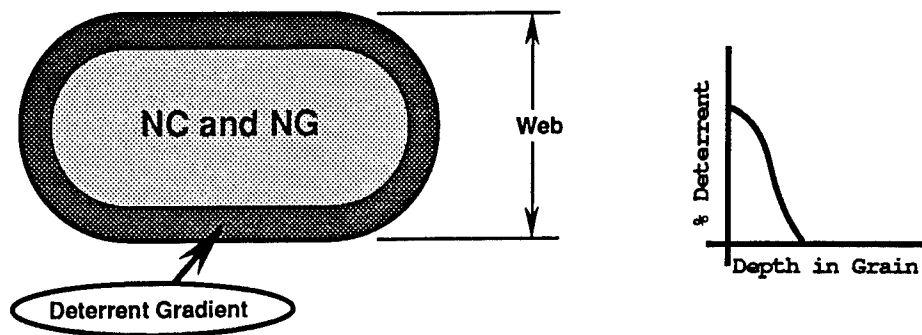

Figure 3. BALL POWDER® Propellant Base Grain.

A test was conducted with a loose BALL POWDER® propellant charge conditioned at 21°C. The charge consisted of 9.5 kg of loose BALL POWDER® propellant. The loading density was 0.97 g/cm<sup>3</sup>. The charge was ignited with a M129 primer. A cross-sectional view of the charge is shown in Figure 4.

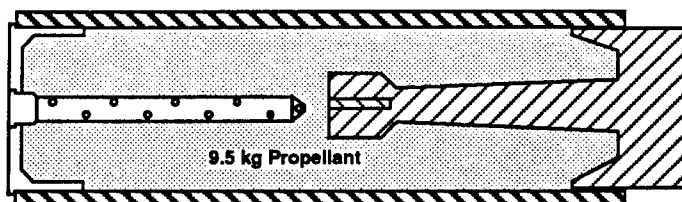

Figure 4. Loose BALL POWDER® Propellant Charge.

The compacted BALL POWDER® propelling charges were made up of several propellant segments. The compacted propellant segments were made by pressing the solvent-wetted propellant grains into shapes which would fit into a 120-mm cartridge case and provide adequate flamespreading throughout the charge. The compacted charge consisted of 9.3 kg of propellant arranged in an inner and outer cylinder with an annular space between them. There was also a small vertical gap between each of the propellant segments. The loading density was 0.95 g/cm<sup>3</sup>. The charge was ignited with a XM123 primer and a 100-g black powder basepad igniter. A cross-sectional view of the charge and propellant segments is shown in Figure 5. Compacted propellant charges were tested at -32°C, 21°C, and 49°C.

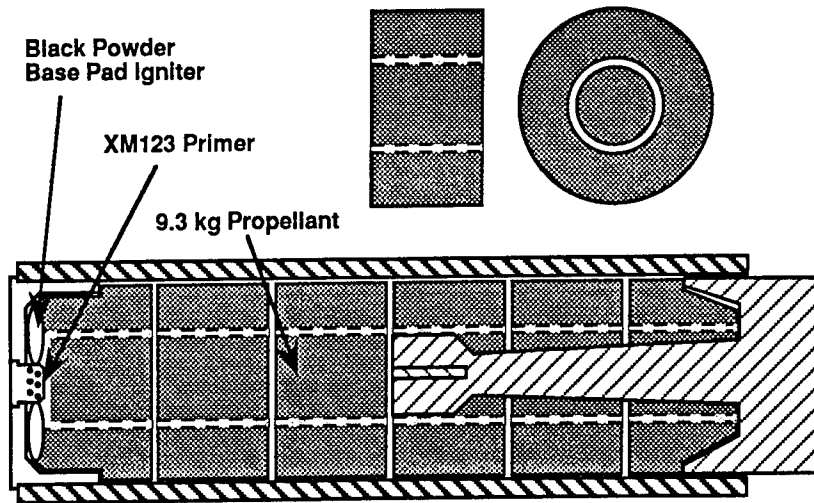

Figure 5. Compacted BALL POWDER® Propellant Charge.

### 3. EXPERIMENTAL RESULTS

3.1 Loose BALL POWDER® Charge, 21°C. The pressure-time and displacement-time histories for the loose BALL POWDER® charge are presented in Figure 6. This charge showed a peak pressure of 10.9 MPa at gage locations P1 and P2, 4.9 MPa at P3, and 0.51 MPa at P4. The oscillations on the pressure-time traces are believed to be caused by various modes of 60 cycle noise. The radar showed projectile motion between 8 and 10 ms, then the projectile stopped and remained stationary until 42 ms. A schematic of the events taking place during the flamespread is shown in Figure 7. At approximately 8 ms, the propellant bed is seen moving forward and impacting the projectile. At 15 ms, the formation of dark areas in the rear quarter of the charge was noted. These areas appeared in a pattern corresponding to that of the vent holes in the primer. These dark areas, which are believed to be combustion products, continued to enlarge. At 32 ms, the first area of flame was seen near the center of one of the dark areas, which is shown in black on the schematic diagram. Other small areas of flames appeared in the other dark areas as time progressed. At 50 ms, there were three areas of flame in the rear of the charge just before the chamber burst.

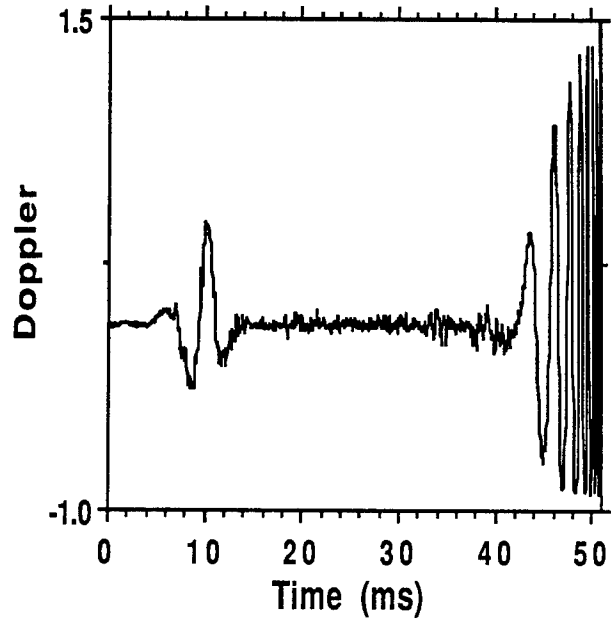
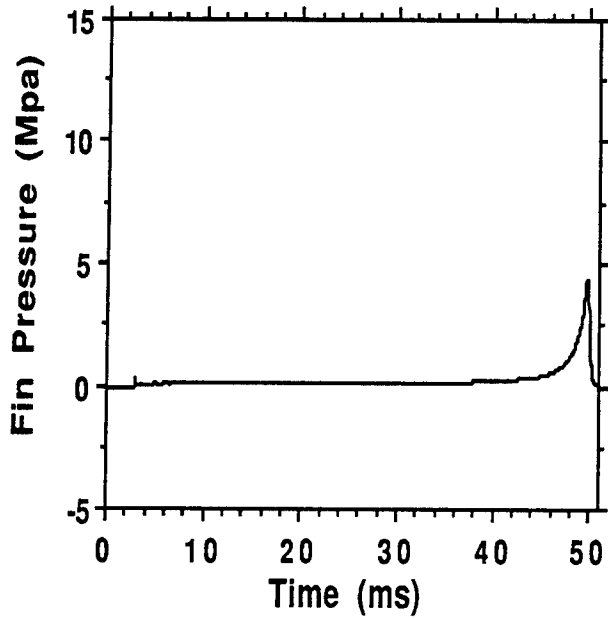
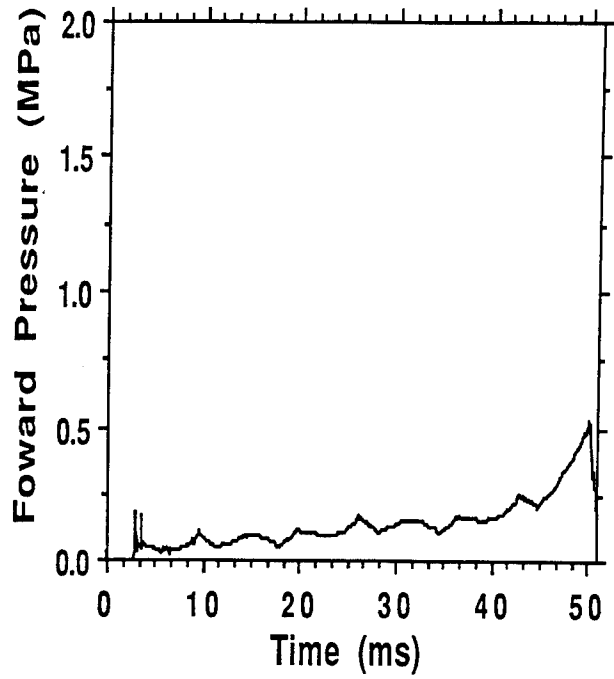
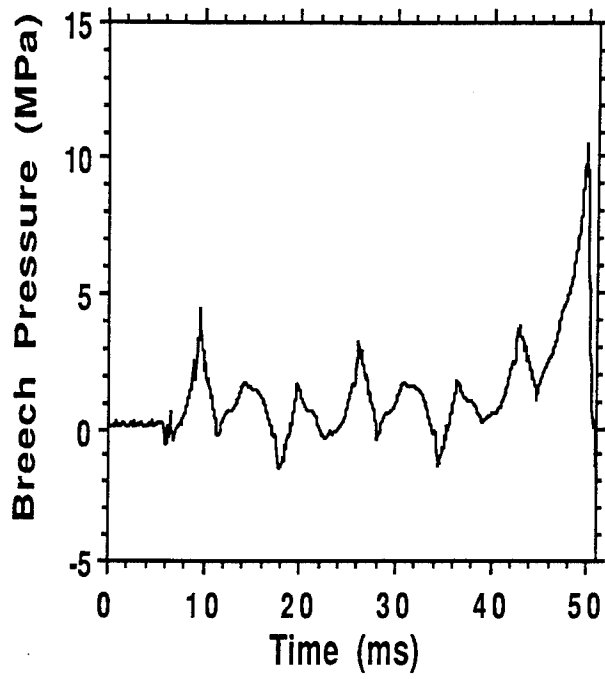

Figure 6. Pressures and Radar Data, Loose BALL POWDER , 21°C.

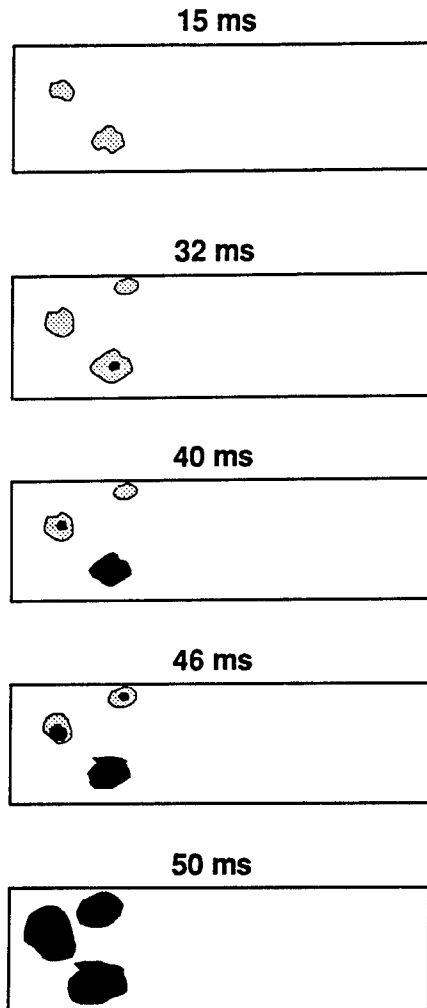

Figure 7. Schematic of Flamespread in Loose BALL POWDER®, 21°C.

3.2 Compacted BALL POWDER® Charge, 21°C. A compacted BALL POWDER® charge was conditioned at 21°C. The pressure-time and displacement-time plots are shown in Figure 8. The round obtained a peak pressure of 11.9 MPa at the breech (P1 and P2), 11.0 MPa at the fins (P3), and 9.2 MPa at the forward end of the chamber (P4). The projectile started to move at approximately 8 ms and accelerated smoothly until the chamber burst. A schematic of the events taking place is shown in Figure 9. At 1 ms, the XM123 primer had ignited the basepad and luminous gases could be seen near the rear of the charge. At 1.5 ms, the luminous gases advanced around the rear two segments and also through the inside of the charge to the forward end of the chamber. The luminous gases continued to spread throughout the charge.

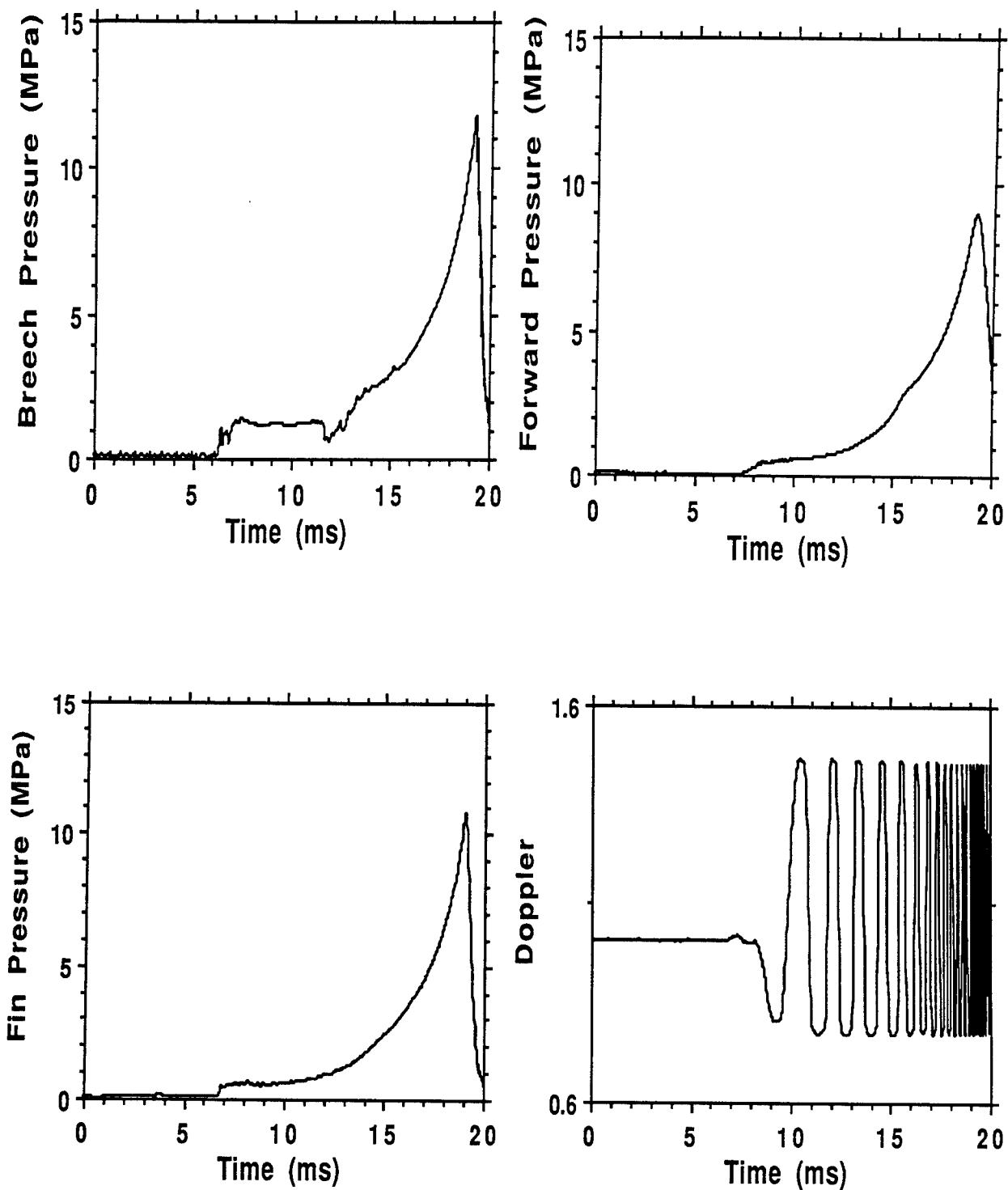

Figure 8. Pressures and Radar Data, Compacted BALL POWDER, 21°C.

At 13.5 ms, the rear of the charge became bright orange, indicating propellant ignition. At 19 ms, the propellant in the center of the charge, as seen through the vertical gaps, became bright orange which indicated propellant ignition at that location.

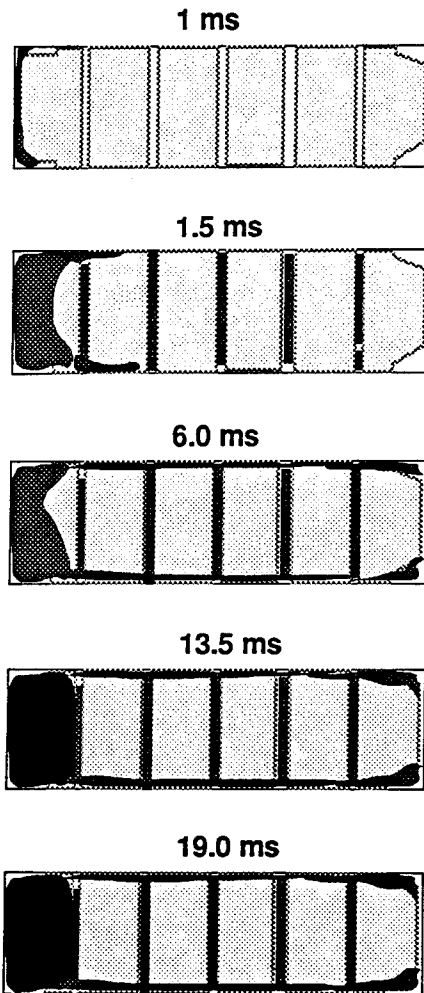

Figure 9. Schematic of Flamespread in Compacted BALL POWDER<sup>®</sup>, 21°C.

3.3 Compacted BALL POWDER<sup>®</sup> Charge, -32°C. A compacted BALL POWDER<sup>®</sup> charge was conditioned at -32°C for use in the ballistic simulator. The pressure-time and displacement-time plots are shown in Figure 10. The round reached a peak pressure of 22.5 MPa at the breech (P1 and P2), 22.0 MPa at the fins (P3), and 21.5 MPa at the forward end of the chamber (P4). Projectile motion started at 1 ms and accelerated smoothly until the chamber burst. A schematic of the events

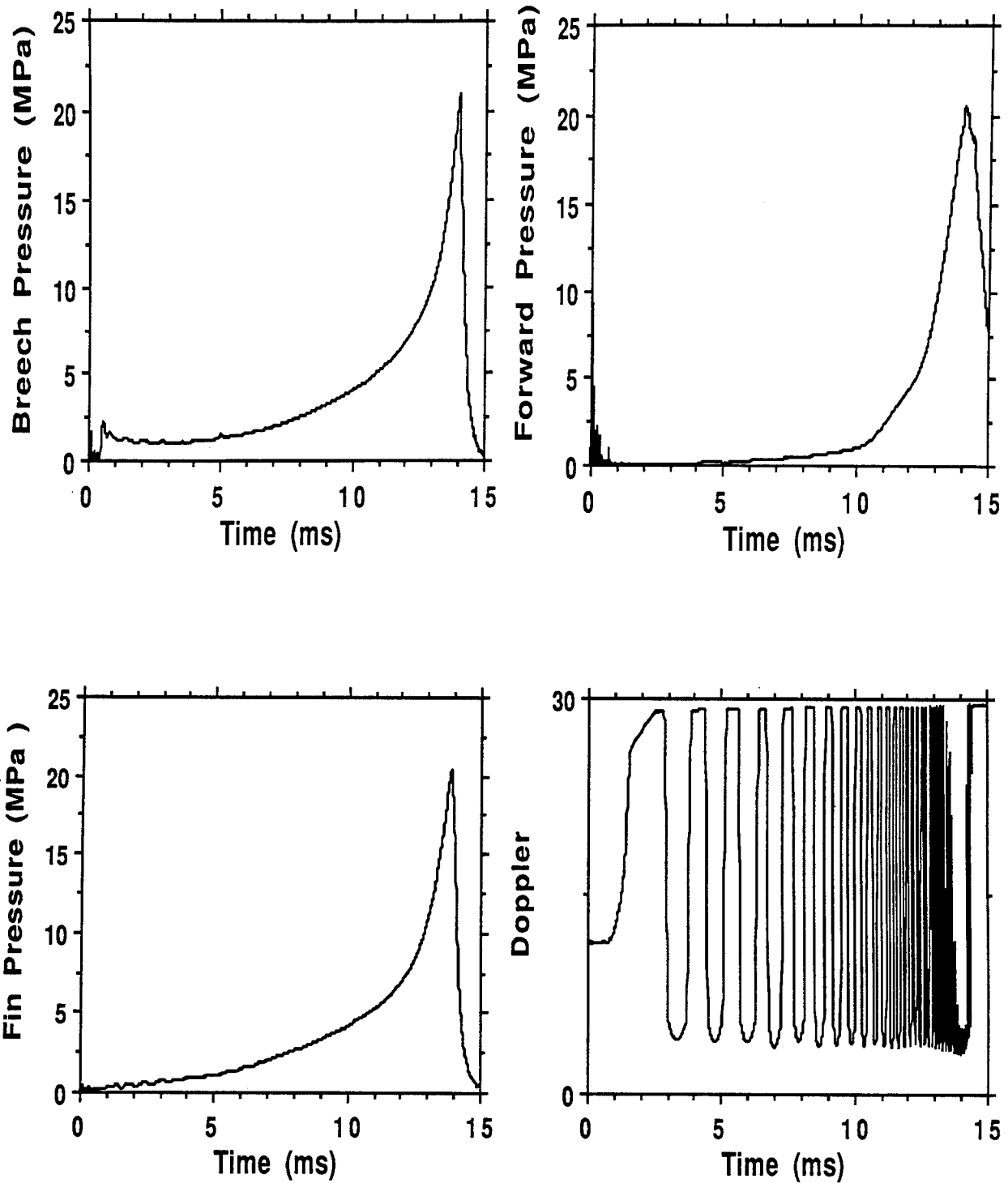

Figure 10. Pressures and Radar Data, Compacted BALL POWDER, -32°C.

taking place is shown in Figure 11. Between 12 and 14 ms the rear half of the charge showed bright, erratic flames, which indicated the propellant was deconsolidating. At 14 ms the chamber burst.

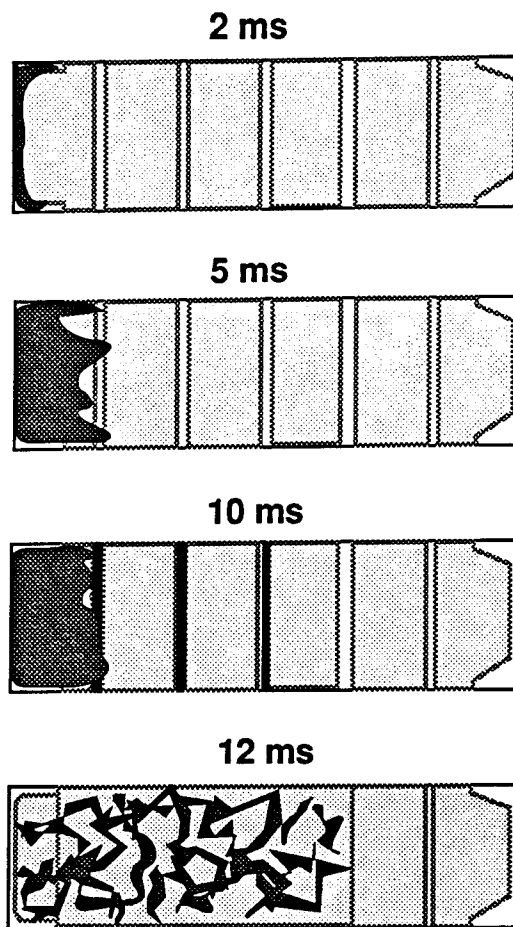

Figure 11. Schematic of Flamespread in Compacted BALL POWDER®, -32°C.

3.4 Compacted BALL POWDER® Charge, 54°C. A compacted BALL POWDER® charge was conditioned at 54°C. The pressure-time and displacement-time plots are shown in Figure 12. The round reached a peak pressure of 13.1 MPa at the breech (P1 and P2), 15.6 MPa at the fins (P3), and 16.4 MPa at the forward end of the chamber (P4). Projectile motion started at approximately 2 ms and accelerated smoothly until the chamber burst. A schematic of the events taking place is shown in Figure 13. At 1 ms, the XM123 primer had ignited the blackpowder basepad and luminous gases could be seen around the rear of the charge. By 3 ms, luminous gases could be seen in the vertical gaps between the segments in the rear half of the charge as well as

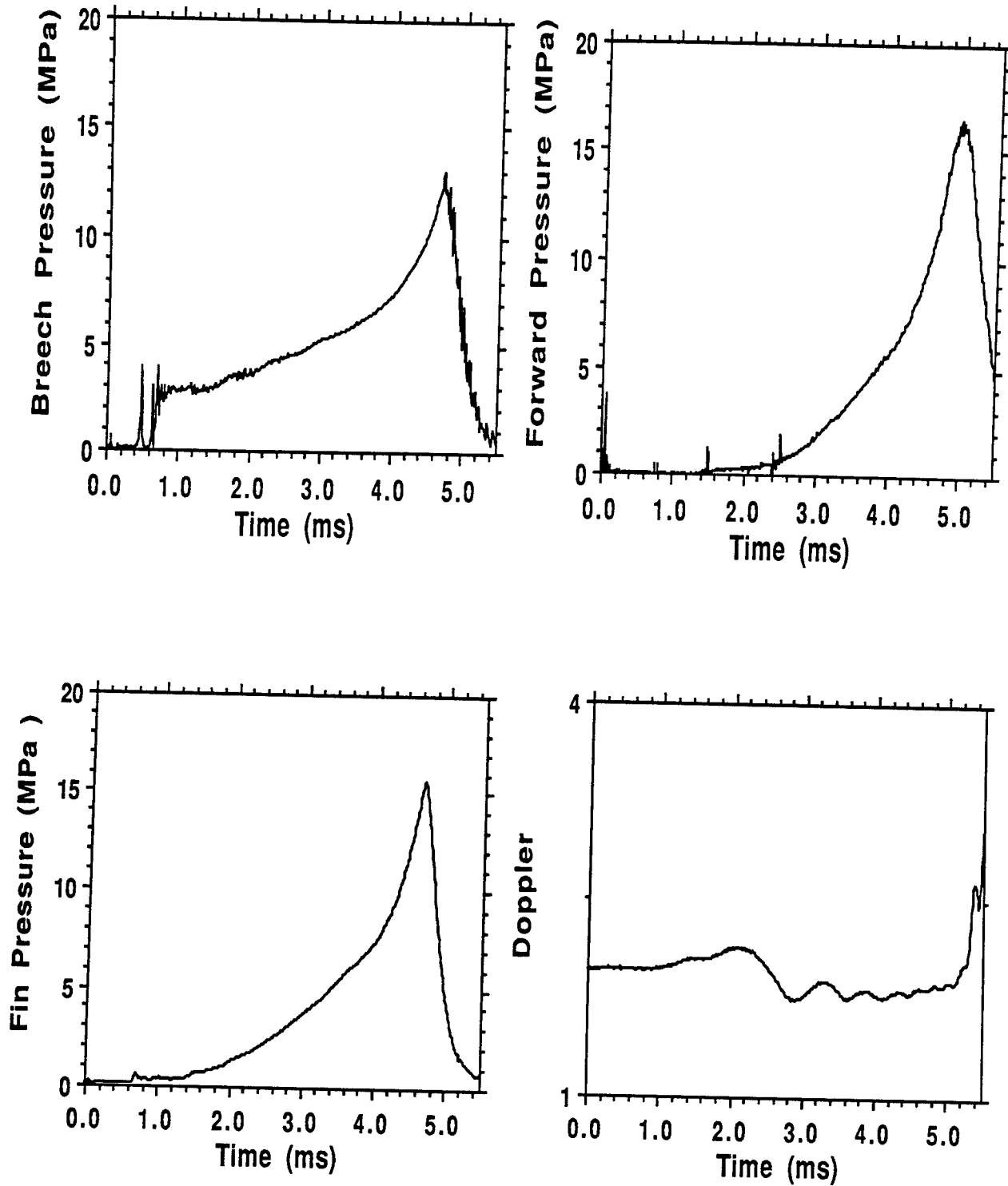

Figure 12. Pressures and Radar Data, Compacted BALL POWDER , 54°C.

in the forward end of the chamber. At 4 ms, the rear section of the charge became bright orange which indicated the propellant had started to ignite. The chamber burst at 4.5 ms.

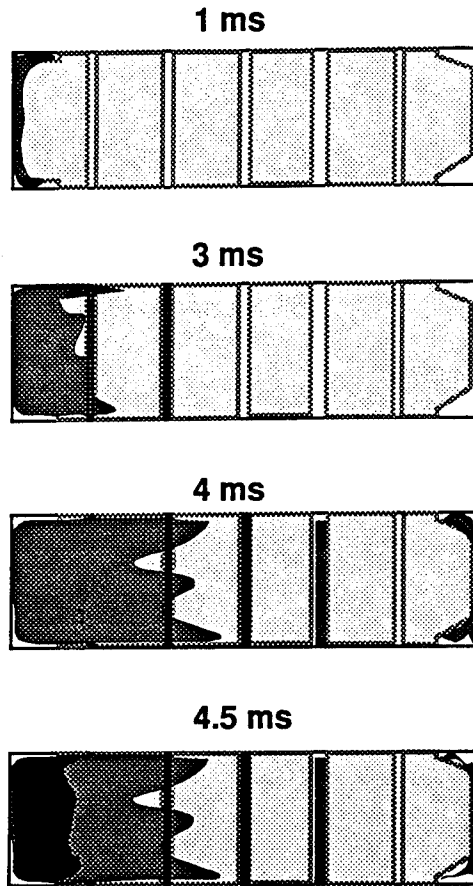

Figure 13. Schematic of Flamespread in Compacted BALL POWDER®, 54°C.

#### 4. CONCLUDING REMARKS

The testing conducted with loose BALL POWDER® propellants showed a very high resistance to the flow of igniter products. This high resistance led to poor flamespread and localized ignition in the base of the charge.

Due to the axial ports, the compacted propellants showed rapid propagation of igniter products to all areas of the chamber, which led to uniform ignition of the charge. The flow could be further enhanced by altering the shapes and sizes of the propellant segments.

Deconsolidation of the compacted propellant was seen only with the charge conditioned at  $-32^{\circ}\text{C}$ . The key to temperature sensitivity reduction is progressively more deconsolidation as the temperature of the charge is reduced. Such deconsolidation took place at  $-32^{\circ}\text{C}$ ; we may not have observed it at  $21^{\circ}\text{C}$  due to earlier simulator chamber failure.

Based on the results obtained during the simulator tests, a series of gun firings is planned in the 120-mm gun with compacted BALL POWDER® propellants conditioned to temperatures spanning the required operational spectrum. The goal is to demonstrate a significantly reduced temperature sensitivity across this range compared to conventional charges.

INTENTIONALLY LEFT BLANK.

## 5. REFERENCES

Chang, L.M., and J.J. Rocchio "Simulator Diagnostics of the Early Phase Ignition Phenomena in a 105-MM Tank Gun Chamber." BRL-TR-2890, U.S. Army Ballistic Research Laboratory, Aberdeen Proving Ground, MD, March 1988.

Kruczynski, D. L. "Temperature Compensation Techniques And Technologies- An Overview." BRL-TR-3283, U.S. Army Ballistic Research Laboratory, Aberdeen Proving Ground, MD, October 1991.

INTENTIONALLY LEFT BLANK

NO. OF COPIES      ORGANIZATION

2      ADMINISTRATOR  
ATTN DTIC DDA  
DEFENSE TECHNICAL INFO CTR  
CAMERON STATION  
ALEXANDRIA VA 22304-6145

1      DIRECTOR  
ATTN AMSRL OP SD TA  
US ARMY RESEARCH LAB  
2800 POWDER MILL RD  
ADELPHI MD 20783-1145

3      DIRECTOR  
ATTN AMSRL OP SD TL  
US ARMY RESEARCH LAB  
2800 POWDER MILL RD  
ADELPHI MD 20783-1145

1      DIRECTOR  
ATTN AMSRL OP SD TP  
US ARMY RESEARCH LAB  
2800 POWDER MILL RD  
ADELPHI MD 20783-1145

ABERDEEN PROVING GROUND

5      DIR USARL  
ATTN AMSRL OP AP L (305)

<u>NO. OF</u> <u>COPIES</u>	<u>ORGANIZATION</u>	<u>NO. OF</u> <u>COPIES</u>	<u>ORGANIZATION</u>
1	HQDA ATTN SARD TT DR F MILTON PENTAGON WASHINGTON DC 20310-0103	11	CDR US ARMY ARDEC ATTN SMCAR AEE B A BEARDELL D DOWNS S EINSTEIN S WESTLEY S BERNSTEIN J RUTKOWSKI B BRODMAN P OREILLY R CIRINCIONE P HUI J OREILLY PCTNY ARSNL NJ 07806-5000
1	HQDA ATTN SARD TT MR J APPEL PENTAGON WASHINGTON DC 20310-0103		
1	CHAIRMAN DOD EXPLOSIVES SAFETY BD HOFFMAN BLDG 1 RM 856 C 2461 EISENHOWER AVE ALEXANDRIA VA 22331-0600		
1	CDR USAMC ATTN AMCICP AD M FISETTE 5001 EISENHOWER AVE ALEXANDRIA VA 22333-0001	5	CDR US ARMY ARDEC ATTN SMCAR AEE WW M MEZGER J PINTO D WIEGAND P LU C HU PCTNY ARSNL NJ 07806-5000
1	USA BMD SYSTEMS COMMAND ADVANCED TECHNOLOGY CTR PO BOX 1500 HUNTSVILLE AL 35807-3801		
2	CDR US ARMY ARDEC ATTN SMCAR CCH V C MANDALA E FENNELL PCTNY ARSNL NJ 07806-5000	1	CDR US ARMY ARDEC ATTN SMCAR HFM E BARRIERES PCTNY ARSNL NJ 07806-5000
1	CDR US ARMY ARDEC ATTN SMCAR CCH T L ROSENDORF PCTNY ARSNL NJ 07806-5000	1	CDR US ARMY ARDEC ATTN SMCAR FSA F LTC R RIDDLE PCTNY ARSNL NJ 07806-5000
1	CDR US ARMY ARDEC ATTN SMCAR CCS PCTNY ARSNL NJ 07806-5000	1	CDR US ARMY ARDEC ATTN SMCAR FSC G FERDINAND PCTNY ARSNL NJ 07806-5000
1	CDR US ARMY ARDEC ATTN SMCAR AEE J LANNON PCTNY ARSNL NJ 07806-5000	1	CDR US ARMY ARDEC ATTN SMCAR FS T GORA PCTNY ARSNL NJ 07806-5000
1	CDR US ARMY ARDEC ATTN SMCAR AES S KAPLOWITZ PCTNY ARSNL NJ 07806-5000	1	CDR US ARMY ARDEC ATTN SMCAR FS DH J FENECK PCTNY ARSNL NJ 07806-5000

<u>NO. OF COPIES</u>	<u>ORGANIZATION</u>
2	CDR US ARMY ARDEC ATTN SMCAR FSS A R KOPMANN B MACHEK PCTNY ARSNL NJ 07806-5000
1	CDR US ARMY ARDEC ATTN SMCAR FSS A L PINDER PCTNY ARSNL NJ 07806-5000
1	CDR US ARMY ARDEC ATTN SMCAR FSN N K CHUNG PCTNY ARSNL NJ 07806-5000
2	DIR BENET LABS ATTN SMCAR CCB RA G P O'HARA G A PFLEGL WATERVLIET NY 12189-4050
1	DIR BENET LABS ATTN SMCAR CCB S S F HEISER WATERVLIET NY 12189-4050
1	DIR BENET LABS ATTN SMCAR CCB RT S SOPOK WATERVLIET NY 12189-4050
2	CDR USARO ATTN TECH LIB D MANN PO BOX 12211 RSCH TRI PK NC 27709-2211
1	CDR USACECOM R&D TECHNICAL LIBRARY ATTN ASQNC ELC IS L R MYER CTR FT MONMOUTH NJ 07703-5301
1	CDR USABRDC ATTN STRBE WC FT BELVOIR VA 22060-5006
1	CDR US ARMY NGIC ATTN AMXST MC 3 220 SEVENTH ST NE CHARLOTTESVILLE VA 22901-5396

<u>NO. OF COPIES</u>	<u>ORGANIZATION</u>
1	US ARMY RD&S GROUP (UK) PSC 802 BOX 15 DR ROY E RICHENBACH FPO AE 09499-1500
1	CDR NSSC ATTN SEA 62R WASH DC 20362-5101
1	CDR NSSC ATTN SEA 64 WASH DC 20362-5101
1	CDR NASC ATTN AIR 954 TECH LIB WASH DC 20360
1	CDR NAVAL RESEARCH LAB ATTN TECH LIB WASH DC 20375-5000
3	CDR NAVAL RESEARCH LAB ATTN CODE 4410 J BORIS K KAILASANATH E ORAN WASH DC 20375-5000
1	OFFICE OF NAVAL RESEARCH ATTN CODE 473 R S MILLER 800 N QUINCY ST ARLINGTON VA 22217-9999
1	OFFICE OF NAVAL TECHNOLOGY ATTN ONT 213 D SIEGEL 800 N QUINCY ST ARLINGTON VA 22217-5000
1	CDR NSWC ATTN CODE 730 SLVR SPRNG MD 20903-5000
1	CDR NSWC ATTN CODE R 13 R BERNECKER SLVR SPRNG MD 20903-5000

<u>NO. OF COPIES</u>	<u>ORGANIZATION</u>	<u>NO. OF COPIES</u>	<u>ORGANIZATION</u>
7	CDR NSWC ATTN TC SMITH K RICE S MITCHELL S PETERS J CONSAGA C GOTZMER TECHNICAL LIBRARY INDIAN HEAD MD 20640-5000	1	AFOSR NA ATTN J TISHKOFF BOLLING AFB DC 20332-6448
1	CDR NSWC ATTN CODE G30 GUNS & MUNITIONS DIVISION DAHLGREN VA 22448-5000	1	OLAC PL TSTL ATTN D SHIPLETT EDWARDS AFB CA 93523-5000
1	CDR NSWC ATTN CODE G32 GUNS SYSTEMS DIVISION DAHLGREN VA 22448-5000	3	OLAC PL RK ATTN J LEVINE L QUINN T EDWARDS 5 POLLUX DRIVE EDWARDS AFB CA 93524-7048
1	CDR NSWC ATTN CODE G33 T DORAN DAHLGREN VA 22448-5000	1	WL MNA ATTN B SIMPSON EGLIN AFB FL 32542-5434
1	CDR NSWC ATTN CODE E23 TECHNICAL LIBRARY DAHLGREN VA 22448-5000	1	WL MNME ENERGETIC MATERIALS BR 2306 PERIMETER RD STE 9 EGLIN AFB FL 32542-5910
2	CDR NAWC ATTN CODE 388 CF PRICE T BOGGS CHINA LAKE CA 93555-6001	1	WL MNSH ATTN R DRABCZUK EGLIN AFB FL 32542-5434
2	CDR NAWC ATTN CODE 3895 T PARR R DERR CHINA LAKE CA 93555-6001	2	NASA LANGLEY RESEARCH CTR ATTN MS 408 W SCALLION D WITCOFSKI HAMPTON VA 23605
1	CDR NAWC ATTN INFORMATION SCIENCE DIVISION CHINA LAKE CA 93555-6001	1	CIA OFC OF INFO RESOURCES ROOM GA 07 HQS WASH DC 20505
1	CDR NUSC ATTN CODE 5B331 TECHNICAL LIBRARY NEWPORT RI 02840	1	CIA ATTN J BACKOFEN NHB ROOM 5N01 WASH DC 20505
		1	SDIO TNI ATTN LH CAVENY PENTAGON WASH DC 21301-7100

<u>NO. OF COPIES</u>	<u>ORGANIZATION</u>
1	SDIO DA ATTN E GERRY PENTAGON WASH DC 21301-7100
2	HQ DNA ATTN D LEWIS A FAHEY 6801 TELEGRAPH RD ALEXANDRIA VA 22310-3398
1	DIR SNL ENRGTC MATLS & FLUID MECH DEPARTMENT 1512 ATTN M BAER PO BOX 5800 ALBUQUERQUE NM 87185
1	DIR SNL COMBUSTION RSCH FACILITY ATTN R CARLING LIVERMORE CA 94551-0469
1	DIR SNL ATTN 8741 GA BENEDETTI PO BOX 969 LIVERMORE CA 94551-0969
2	DIR LLNL ATTN L 355 A BUCKINGHAM M FINGER PO BOX 808 LIVERMORE CA 94550-0622
1	DIR LANL ATTN T3 D BUTLER PO BOX 1663 LOS ALAMOS NM 87544
1	DIR LANL ATTN M DIV B CRAIG PO BOX 1663 LOS ALAMOS NM 87544
2	BATTELLE ATTN TWSTIAC V LEVIN 505 KING AVE COLUMBUS OH 43201-2693

<u>NO. OF COPIES</u>	<u>ORGANIZATION</u>
1	BATTELLE PNL ATTN MCC BAMPTON PO BOX 999 RICHLAND WA 99352
1	INSTITUTE OF GAS TECH ATTN D GIDASPOW 3424 S STATE ST CHICAGO IL 60616-3896
1	INST FOR ADV TECHNOLOGY ATTN T M KIEHNE 4030 2 W BRAKER LANE AUSTIN TX 78759-5329
2	CPIA JHU ATTN H J HOFFMAN T CHRISTIAN 10630 LTLE PATUXENT PKWY SUITE 202 COLUMBIA MD 21044-3200
1	BRIGHAM YOUNG UNIVERSITY DEPT OF CHEMICAL ENGNRNG ATTN M BECKSTEAD PROVO UT 84601
1	JET PROPULSION LAB CA INSTITUTE OF TECH ATTN L STRAND MS 125 224 4800 OAK GROVE DRIVE PASADENA CA 91109
1	CA INSTITUTE OF TECH 204 KARMAN LABORATORY MAIL STOP 301 46 ATTN F E C CULICK 1201 E CALIFORNIA ST PASADENA CA 91109
3	GEORGIA INST OF TECH SCH OF AEROSPACE ENGRNG ATTN B T ZIM E PRICE WC STRAHLE ATLANTA GA 30332

<u>NO. OF COPIES</u>	<u>ORGANIZATION</u>	<u>NO. OF COPIES</u>	<u>ORGANIZATION</u>
2	UNIV OF ILLINOIS DEPT OF MECH INDUS ENGR ATTN H KRIER R BEDDINI 144 MEB 1206 N GREEN ST URBANA IL 61801-2978	1	AFELM THE RAND CORP ATTN LIBRARY D 1700 MAIN ST SANTA MONICA CA 90401-3297
1	UNIV OF MASSACHUSETTS DEPT OF MECH ENGR ATTN K JAKUS AMHERST MA 01002-0014	1	ARROW TECH ASSOC INC ATTN W HATHAWAY PO BOX 4218 S BURLINGTON VT 05401-0042
1	UNIV OF MINNESOTA DEPT OF MECH ENGR ATTN E FLETCHER MINNEAPOLIS MN 55414-3368	2	AAI CORPORATION ATTN J FRANKLE D CLEVELAND PO BOX 126 HUNT VALLEY MD 21030-0126
3	PENN STATE UNIV DEPT OF MECH ENGR ATTN V YANG K KUO C MERKLE UNIV PARK PA 16802-7501	2	ALLIANT TECHSYSTEMS INC ATTN RE TOMPKINS J KENNEDY 7225 NORTHLAND DR BRKLYN PARK MN 55428
1	RENSSELAER POLYTECH INST DEPT OF MATHEMATICS TROY NY 12181	1	GENERAL APPLIED SCI LAB ATTN J ERDOS 77 RAYNOR AVE RONKONKOMA NY 11779-6649
1	STEVENS INST OF TECH DAVIDSON LABORATORY ATTN R MCALEVY III CASTLE POINT STATION HOBOKEN NJ 07030-5907	1	GENERAL ELECTRIC COMPANY TACTICAL SYSTEM DEPT ATTN J MANDZY 100 PLASTICS AVE PITTSFIELD MA 01201-3698
1	RUTGERS UNIVERSITY DEPT OF MECHANICAL AND AEROSPACE ENGINEERING ATTN S TEMKIN UNIVERSITY HEIGHTS CAMPUS NEW BRUNSWICK NJ 08903	1	IITRI ATTN MJ KLEIN 10 W 35TH ST CHICAGO IL 60616-3799
1	UNIVERSITY OF UTAH DEPT OF CHEM ENGRG ATTN A BAER SALT LK CTY UT 84112-1194	4	HERCULES INC RADFORD ARMY AMMUNITION PLANT ATTN L GIZZI D A WORRELL W J WORRELL C CHANDLER RADFORD VA 24141-0299
1	WASHINGTON STATE UNIV DEPT OF MECH ENGRG ATTN CT CROWE PULLMAN WA 99163-5201	2	HERCULES INC ALLEGHENY BALLISTICS LAB ATTN WILLIAM B WALKUP THOMAS F FARABAUGH PO BOX 210 ROCKET CTR WV 26726

<u>NO. OF COPIES</u>	<u>ORGANIZATION</u>
1	HERCULES INC AEROSPACE ATTN R CARTWRIGHT 100 HOWARD BLVD KENVILLE NJ 07847
1	HERCULES INC HERCULES PLAZA ATTN BM RIGGLEMAN WILMINGTON DE 19894
1	MBR RESEARCH INC ATTN MOSHE BEN REUVEN 601 EWING ST SUITE C 22 PRINCETON NJ 08540
3	OLIN ORDNANCE ATTN EJ KIRSCHKE A F-GONZALEZ D W WORTHINGTON PO BOX 222 ST MARKS FL 32355-0222
1	OLIN ORDNANCE ATTN H A MCELROY 10101 9TH ST NORTH ST PETERSBURG FL 33716
1	PAUL GOUGH ASSOC INC ATTN PS GOUGH 1048 SOUTH ST PORTSMOUTH NH 03801-5423
1	PHYSICS INTL LIBRARY ATTN H WAYNE WAMPLER PO BOX 5010 SAN LEANDRO CA 94577-0599
1	PRINCETON CMBSTN RSCH LABS ATTN N A MESSINA PRINCETON CORPORATE PLAZA 11 DEERPARK DR BLDG IV SUITE 119 MONMOUTH JUNCTION NJ 08852
2	ROCKWELL INTERNATIONAL ROCKETDYNE DIVISION ATTN BA05 J FLANAGAN J GRAY 6633 CANOGA AVE CANOGA PARK CA 91303-2703

<u>NO. OF COPIES</u>	<u>ORGANIZATION</u>
1	ROCKWELL INTERNATIONAL ROCKETDYNE DIVISION ATTN WC79 R EDELMAN 6633 CANOGA AVE CANOGA PARK CA 91303-2703
2	ROCKWELL INTL SCIENCE CTR ATTN DR S CHAKRAVARTHY DR S PALANISWAMY 1049 CAMINO DOS RIOS THOUSAND OAKS CA 91360
1	SAIC ATTN M PALMER 2109 AIR PARK RD ALBUQUERQUE NM 87106
1	SOUTHWEST RSCH INST ATTN J P RIEGEL 6220 CULEBRA ROAD SAN ANTONIO TX 78228-0510
1	SVERDRUP TECHNOLOGY INC ATTN DR JOHN DEUR 2001 AEROSPACE PARKWAY BROOK PARK OH 44142
3	THIOKOL CORPORATION ELKTON DIVISION ATTN R WILLER R BIDDLE TECH LIBRARY PO BOX 241 ELKTON MD 21921-0241
1	VERITAY TECHNOLOGY INC ATTN E FISHER 4845 MILLERSPORT HWY EAST AMHRST NY 14501-0305
1	UNIVERSAL PROPULSION CO ATTN HJ MCSPADDEN 25401 NORTH CENTRAL AVE PHOENIX AZ 85027-7837
1	SRI INTERNATIONAL PROPULSION SCI DIV ATTN TECH LIBRARY 333 RAVENWOOD AVE MENLO PARK CA 94025-3493

<u>NO. OF COPIES</u>	<u>ORGANIZATION</u>	<u>NO. OF COPIES</u>	<u>ORGANIZATION</u>
1	DEPARTMENT OF THE ARMY ATTN SFAE AR HIP IP R DE KLEINE OFFICE OF THE PRODUCT MANAGER 155 MM HOWITZER M109A6 PALADIN PCTNY ARSNL NJ 07806-5000	1	PEO ARMAMENTS ATTN AMCPM TMA AS H YUEN PROJECT MANAGER TMAS PCTNY ARSNL NJ 07806-5000
3	PROJECT MANAGER ATTN SFAE ASM AF E LTC A ELLIS T KURIATA J SHIELDS ADVANCED FIELD ARTILLERY SYSTEM PCTNY ARSNL NJ 07801-5000	1	CDR ATTN SMCAR FSA T M SALSBUURY US ARMY ARDEC PCTNY ARSNL NJ 07806-5000
1	PROJECT MANAGER ATTN SFAE ASM AF Q W WARREN US ARMY AFAS PCTNY ARSNL NJ 07801-5000	1	COMMANDANT ATTN AVIATION AGENCY US ARMY AVIATION SCHOOL FT RUCKER AL 36360
1	CDR ATTN AMSMC PBM A SIKLOSI PROD BASE MODRNZTIN AGCY US ARMY ARDEC PCTNY ARSNL NJ 07806-5000	1	PROGRAM MANAGER ATTN AMCPM ABMS T DEAN US ARMY TACOM WARREN MI 48092-2498
1	CDR ATTN AMSMC PBM E L LAIBSON PROD BASE MODRNZTIN AGCY US ARMY ARDEC PCTNY ARSNL NJ 07806-5000	1	PROJECT MANAGER ATTN SFAE ASM BV US ARMY TACOM FIGHTING VEHICLE SYSTEMS WARREN MI 48397-5000
1	PEO ARMAMENTS ATTN AMCPM TMA PROJECT MANAGER TMAS PCTNY ARSNL NJ 07806-5000	1	PROJECT MANAGER ATTN SFAE ASM AB ABRAMS TANK SYSTEM WARREN MI 48397-5000
1	PEO ARMAMENTS ATTN AMCPM TMA 105 PROJECT MANAGER TMAS PCTNY ARSNL NJ 07806-5000	1	DIRECTOR ATTN ATCD MA HQ TRAC RPD FT MONROE VA 23651-5143
1	PEO ARMAMENTS ATTN AMCPM TMA 120 PROJECT MANAGER TMAS PCTNY ARSNL NJ 07806-5000	1	DIRECTOR ATTN ATRC L MR CAMERON US ARMY TRAC FT LEE FT LEE VA 23801-6140
1	PEO ARMAMENTS ATTN AMCPM TMA 120 PROJECT MANAGER TMAS PCTNY ARSNL NJ 07806-5000	1	COMMANDANT US ARMY CMND AND GEN STAFF COLLEGE FT LEAVENWORTH KS 66027
1	PEO ARMAMENTS ATTN AMCPM TMA 120 PROJECT MANAGER TMAS PCTNY ARSNL NJ 07806-5000	1	COMMANDANT ATTN REV AND TRNG LIT DIV US ARMY SPECIAL WARFARE SCHOOL FT BRAGG NC 28307

<u>NO. OF COPIES</u>	<u>ORGANIZATION</u>
1	CDR ATTN SMCAR QA HI LIB RADFORD ARMY AMMUNITION PLANT RADFORD VA 24141-0298
2	COMMANDANT ATTN ATSF CD COL T STRICKLIN ATSF CN P GROSS US ARMY FLD ARTLY CTR AND SCHL FT SILL OK 73503-5600
1	COMMANDANT ATTN ATZK CD MS M FALKOVITCH US ARMY ARMOR SCHOOL ARMOR AGENCY FT KNOX KY 40121-5215
1	MARTIN MARIETTA ARMAMENT SYSTEMS ATTN JIM TALLEY ROOM 1309 LAKESIDE AVE BURLINGTON VT 05401
1	OLIN CORPORATION ATTN F E WOLF BADGER ARMY AMMUNITION PLANT BARABOO WI 53913
	<u>ABERDEEN PROVING GROUND</u>
1	CDR USACSTA ATTN STECS LI R HENDRICKSON
110	DIR USARL ATTN AMSRL WT I MAY D ECCLESHALL AMSRL CI C MERMEGAN AMSRL CI C W STUREK AMSRL CI S A MARK AMSRL SL B P DIETZ AMSRL SL I D HASKILL AMSRL WT P A HORST J DANTE AMSRL WT PA T MINOR C LEVERITT D KOOKER R ANDERSON A BIRK

<u>NO. OF COPIES</u>	<u>ORGANIZATION</u>
	A BRANT C BULLOCK L CHANG T COFFEE J COLBURN P CONROY M DEL GUERCIO J DE SPIRITO S FORTIER G GAZONAS J HEWITT S HOWARD A JOHNSON A JUHASZ G KATULKA G KELLER M KIWAN J KNAPTON A KOSZORU D KRUCZYNSKI F LIBERATORE M MCQUAID M NUSCA W OBERLE P REEVES M RIDGLEY F ROBBINS T ROSENBERGER C RUTH I STOBIE P TRAN J TUERK K WHITE A WILLIAMS G WREN AMSRL WT PB E SCHMIDT P PLOSTINS M BUNDY W THOMSPON AMSRL WT PC R FIFER G ADAMS W ANDERSON R BEYER S BUNTE A COHEN B FORCH A KOTLAR J HEIMERL M MILLER A MIZIOLEK

NO. OF  
COPIES ORGANIZATION

R PESCE RODRIGUEZ  
M SCHROEDER  
J VANDERHOFF  
AMSRL WT PD  
B BURNS  
A ABRAHAMIAN  
W DRYSDALE  
K BANNISTER  
J BENDER  
L BURTON  
T ERLINE  
A FRYDMAN  
D HOPKINS  
R KASTE  
M LEADORE  
R LIEB  
S WILKERSON  
AMSRL WT T W MORRISON  
AMSRL WT TA  
W GILLICH  
M BURKINS  
AMSRL WT TB  
R FREY  
L VANDE KIEFT  
AMSRL WT TC  
W DE ROSSET  
B SORENSEN  
G SILSBY  
AMSRL WT TD A DIETRICH  
AMSRL WT NC J POLK  
AMSRL WT W C MURPHY  
AMSRL WT WA  
H ROGERS  
B MOORE  
A BARAN  
AMSRL WT WB  
F BRANDON  
W D'AMICO  
AMSRL WT WC  
J ROCCHIO  
T BROSSAU  
B HAUG  
AMSRL WT WD A NIILER  
AMSRL WT WE  
J TEMPERLEY  
J THOMAS  
AMSRL CI A  
H BREAUX  
A CELMINS  
AMSRL CI AC J GROSH  
AMSRL SL I M STARKS  
AMSRL SL BG D KIRK

NO. OF  
COPIES ORGANIZATION

AMSRL SL BL G BOWERS  
AMSRL SL BS J JACOBSON  
AMSRL SL BV A YOUNG

NO. OF  
COPIES ORGANIZATION

- 1 DEFNS RSRCH AGCY MLTRY DIV  
ATTN C WOODLEY  
RARDE FT HALSTEAD  
SEVENOAKS KENT TN14 7BP  
ENGLAND
- 1 SCHL OF MECHL MTRLS AND CIVIL ENGRG  
ATTN DR BRYAN LAWTON  
ROYAL MILITARY COLLEGE OF SCIENCE  
SHRIVANHAM SWINDON WILTSHIRE SN6  
8LA  
ENGLAND
- 2 INSTITUT SAINT LOUIS  
ATTN DR MARC GIRAUD  
DR GUNTHER SMEETS  
POSTFACH 1260  
7858 WEIL AM RHEIN 1  
GERMANY
- 1 EXPLOSIVE ORDNANCE DIVISION  
ATTN A WILDEGGER-GAISSMAIER  
DEFNS SCIENCE AND TECHLGY ORGNZTN  
PO BOX 1750  
SALISBURY SOUTH AUSTRALIA 5108
- 1 ARMAMENTS DIVISION  
ATTN DR J LAVIGNE  
DEFNS RSRCH ESTLSHMNT VALCARTIER  
2459 PIE XI BLVD NORTH  
PO BOX 8800  
COURCELETTE QUEBEC G0A 1R0  
CANADA
- 1 ERNST MACH INSTITUT  
ATTN DR R HEISER  
HAUPSTRASSE 18  
WEIL AM RHEIM  
GERMANY

**INTENTIONALLY LEFT BLANK.**

USER EVALUATION SHEET/CHANGE OF ADDRESS

This Laboratory undertakes a continuing effort to improve the quality of the reports it publishes. Your comments/answers to the items/questions below will aid us in our efforts.

1. ARL Report Number ARL-TR-731 Date of Report April 1995

2. Date Report Received \_\_\_\_\_

3. Does this report satisfy a need? (Comment on purpose, related project, or other area of interest for which the report will be used.) \_\_\_\_\_  
\_\_\_\_\_  
\_\_\_\_\_

4. Specifically, how is the report being used? (Information source, design data, procedure, source of ideas, etc.) \_\_\_\_\_  
\_\_\_\_\_  
\_\_\_\_\_

5. Has the information in this report led to any quantitative savings as far as man-hours or dollars saved, operating costs avoided, or efficiencies achieved, etc? If so, please elaborate. \_\_\_\_\_  
\_\_\_\_\_  
\_\_\_\_\_

6. General Comments. What do you think should be changed to improve future reports? (Indicate changes to organization, technical content, format, etc.) \_\_\_\_\_  
\_\_\_\_\_  
\_\_\_\_\_

CURRENT ADDRESS

\_\_\_\_\_  
Organization  
\_\_\_\_\_  
Name  
\_\_\_\_\_  
Street or P.O. Box No.  
\_\_\_\_\_  
City, State, Zip Code

7. If indicating a Change of Address or Address Correction, please provide the Current or Correct address above and the Old or Incorrect address below.

OLD ADDRESS

\_\_\_\_\_  
Organization  
\_\_\_\_\_  
Name  
\_\_\_\_\_  
Street or P.O. Box No.  
\_\_\_\_\_  
City, State, Zip Code

(Remove this sheet, fold as indicated, tape closed, and mail.)  
(DO NOT STAPLE)

---

DEPARTMENT OF THE ARMY

OFFICIAL BUSINESS

**BUSINESS REPLY MAIL**  
FIRST CLASS PERMIT NO 0001,APG,MD

POSTAGE WILL BE PAID BY ADDRESSEE

DIRECTOR  
U.S. ARMY RESEARCH LABORATORY  
ATTN: AMSRL-WT-PA  
ABERDEEN PROVING GROUND, MD 21005-5066



NO POSTAGE  
NECESSARY  
IF MAILED  
IN THE  
UNITED STATES

