

A Hierarchical Fuzzy Controller for Beam Rider Guidance With a Forbidden Zone

A. F. Bessacini
R. F. Pinkos
Combat Systems Department

12

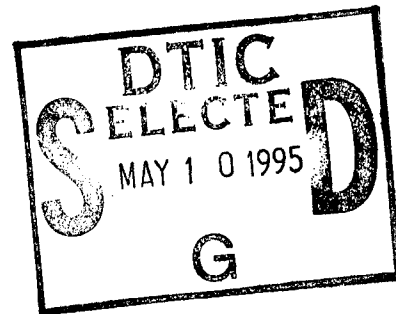

19950509 054

Naval Undersea Warfare Center Division
Newport, Rhode Island

PREFACE

This report was prepared under the NUWC Bid and Proposal (B&P) Program. The B&P Program provides funding for preliminary, conceptual, and technical work necessary for the generation of complete and comprehensive proposals for direct-funded work.

The technical reviewer for this report was W. G. Ravo (Code 2211).

Reviewed and Approved: 7 March 1995

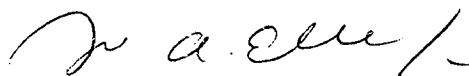
A handwritten signature in cursive script, appearing to read "P. A. La Brecque".

P. A. La Brecque
Head, Combat Systems Department

REPORT DOCUMENTATION PAGE

Form Approved
OMB No. 0704-0188

Public reporting for this collection of information is estimated to average 1 hour per response, including the time for reviewing instructions, searching existing data sources, gathering and maintaining the data needed, and completing and reviewing the collection of information. Send comments regarding this burden estimate or any other aspect of this collection of information, including suggestions for reducing this burden, to Washington Headquarters Services, Directorate for Information Operations and Reports, 1215 Jefferson Davis Highway, Suite 1204, Arlington, VA 22202-4302, and to the Office of Management and Budget, Paperwork Reduction Project (0704-0188), Washington, DC 20503.

1. AGENCY USE ONLY (Leave blank)	2. REPORT DATE 7 March 1995	3. REPORT TYPE AND DATES COVERED Final	
4. TITLE AND SUBTITLE A Hierarchical Fuzzy Controller for Beam Rider Guidance With a Forbidden Zone		5. FUNDING NUMBERS	
6. AUTHOR(S) A. F. Bessacini R. F. Pinkos		8. PERFORMING ORGANIZATION REPORT NUMBER TR 10,392	
7. PERFORMING ORGANIZATION NAME(S) AND ADDRESS(ES) Naval Undersea Warfare Center Division 1176 Howell Street Newport, RI 02841-1708		10. SPONSORING/MONITORING AGENCY REPORT NUMBER	
9. SPONSORING/MONITORING AGENCY NAME(S) AND ADDRESS(ES)		11. SUPPLEMENTARY NOTES	
12a. DISTRIBUTION/AVAILABILITY STATEMENT Approved for public release; distribution is unlimited.		12b. DISTRIBUTION CODE	
13. ABSTRACT (Maximum 200 words) <p>Beam rider guidance is a well understood strategy wherein the goal is to maintain a vehicle on a trajectory such that its bearing and the bearing of the contact being pursued coincide. The problem of automatic, external control of an underwater vehicle such that it obeys a beam rider guidance law while remaining outside a region defined relative to a time-varying measurement is addressed herein. The approach uses fuzzy set theory to develop a hierarchical controller that deals with multiple competing goals and determines the necessary commands to be sent over a two-way communication link between the launching platform and the vehicle being guided. Control of the vehicle entails the use of a time-varying data input stream from the launching platform sensor. The controller is implemented in a simulation to demonstrate and analyze performance.</p>			
14. SUBJECT TERMS Combat Control Systems Beam Rider Guidance		15. NUMBER OF PAGES 34	
Hierarchical Controllers Fuzzy Logic and Control		16. PRICE CODE	
17. SECURITY CLASSIFICATION OF REPORT Unclassified	18. SECURITY CLASSIFICATION OF THIS PAGE Unclassified	19. SECURITY CLASSIFICATION OF ABSTRACT Unclassified	20. LIMITATION OF ABSTRACT SAR

TABLE OF CONTENTS

Section	Page
LIST OF ILLUSTRATIONS.....	ii
LIST OF TABLES.....	ii
1 INTRODUCTION.....	1
2 FORMULATION.....	3
2.1 System Overview.....	3
2.2 Hierarchical Beam Rider Fuzzy Control Subsystem.....	5
2.2.1 Forbidden Zone.....	5
2.2.2 Primary Goal Error Unit.....	6
2.2.3 Secondary Goal Error Unit.....	6
2.2.4 Multi-Goal Fuzzification Unit.....	6
2.2.5 Multi-Goal Rule-Base Unit.....	11
2.2.6 Defuzzification Unit.....	16
2.2.7 Command Conditioner Unit.....	16
2.3 System Operation.....	17
3 SIMULATION RESULTS.....	19
3.1 Hierarchical vs Non-Hierarchical Control.....	19
3.2 Stationary Bearing Input.....	25
3.3 Linear Motion.....	27
4 CONCLUSIONS.....	29
5 REFERENCES.....	31

Accession For	
NTIS CRA&I	<input checked="" type="checkbox"/>
DTIC TAB	<input type="checkbox"/>
Unannounced	<input type="checkbox"/>
Justification	
By	
Distribution /	
Availability Codes	
Dist	Avail and/or Special
A-1	

LIST OF ILLUSTRATIONS

Figure	Page
1	Beam Rider Trajectory Geometry 1
2	Block Diagram of Overall System 2
3	Geometry for Guidance Point Control With Forbidden Zone 3
4	Overall System Structure for Beam Rider Control 4
5	Hierarchical Beam Rider Fuzzy Control System 4
6	Graphical Representation of the Membership Functions for the Fuzzy Inputs for Primary Goal 8
7	Graphical Representation of the Membership Functions for the Fuzzy Inputs for the Secondary Goal and Output Control Set 10
8	Multi-Goal Rule-Base Unit 12
9	Matrices for Primary Goal in Rule-Base Unit 12
10	Matrices for Secondary Goal in Rule-Base Unit 13
11	Example of the Determination of the Composite Implication Function 15
12	Representation of the Command Conditioning Unit 17
13a	Example of Hierarchical Fuzzy Beam Rider Trajectory 20
13b	Separation Angle vs Vehicle Range 20
14a	Boundary Separation Error for Run Number 1 21
14b	Guidance Point Bearing for Run Number 1 21
14c	Hierarchical Beam Rider Trajectory for Run Number 1 22
15a	Boundary Separation Error for Run Number 2 23
15b	Guidance Point Bearing Error for Run Number 2 24
15c	Beam Rider Trajectory for Run Number 2 24
16a	Boundary Separation Error for Run Number 3 25
16b	Guidance Point Bearing Error for Run Number 3 26
16c	Hierarchical Beam Rider Trajectory for Run Number 3 26
17a	Boundary Separation Error for Run Number 4 27
17b	Guidance Point Bearing Error for Run Number 4 28
17c	Hierarchical Beam Rider Trajectory for Run Number 4 28

LIST OF TABLES

Table	Page
1	C and δ Constants for Primary Goal Membership Functions 11
2	C and δ Constants for Secondary Goal and Output Membership Functions 11

A HIERARCHICAL FUZZY CONTROLLER FOR BEAM RIDER GUIDANCE WITH A FORBIDDEN REGION

1. INTRODUCTION

Beam rider guidance is a well understood strategy wherein the goal is to maintain a vehicle on a trajectory such that its bearing and the bearing of the contact being pursued coincide (figure 1). This technique is employed in present submarine combat control systems (SCCS) for post-launch control of a torpedo. Although automatic vehicle control schemes that accomplish this objective have been formulated, SCCS have been reluctant to implement these approaches, retaining man-in-the-loop schemes as the "norm." However, operator loading in complex multisensor/multivehicle operational scenarios now provides the motivation to develop and employ robust, automatic, guidance schemes that allow a system operator to focus attention on tasks of a more supervisory, decision-making nature.

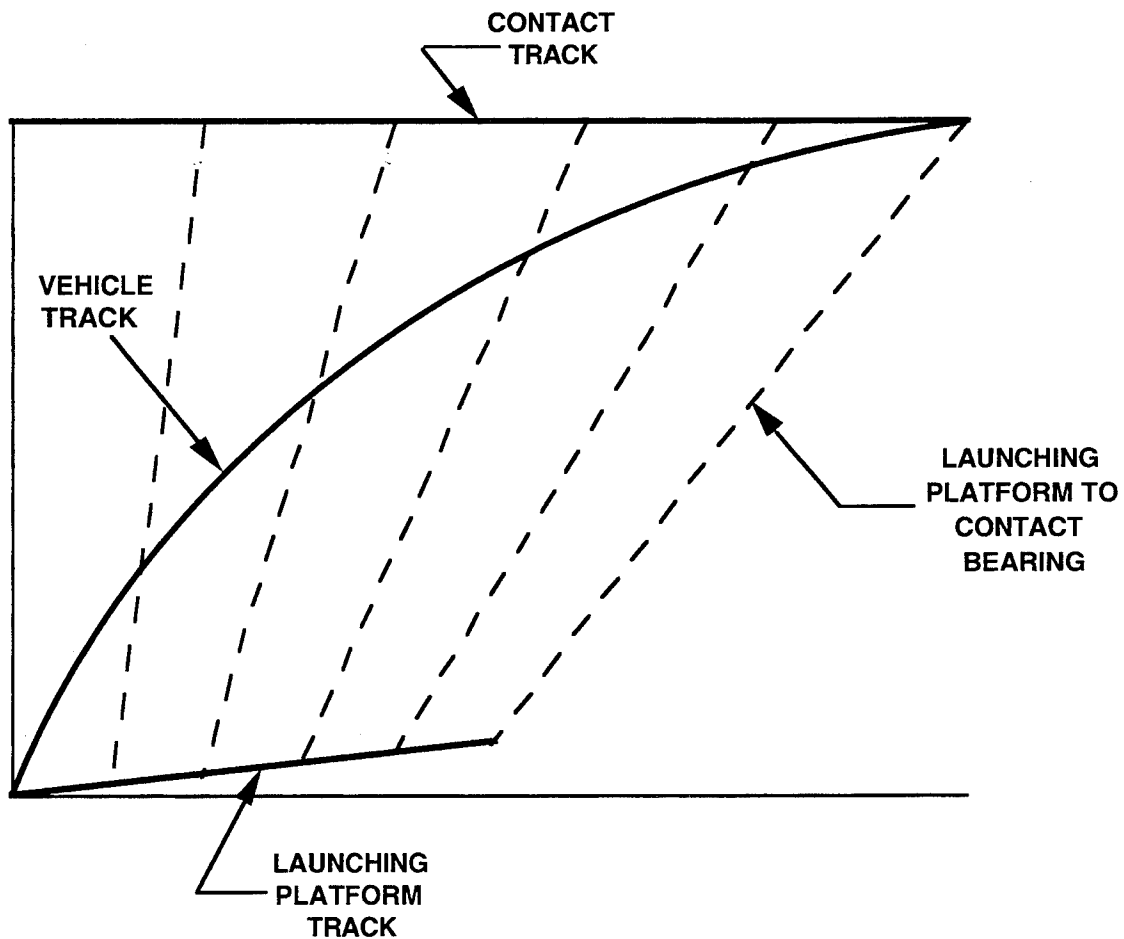

Figure 1. Beam Rider Trajectory Geometry

An overall block diagram of the system being addressed is depicted in figure 2. The problem can be described as one in which a vehicle is launched from a moving platform. Sensors aboard the platform obtain noisy, time-varying measurements of the bearing to the contact. A two-way communication link is available between the vehicle and launcher; this serves as the information channel that allows the launching platform to send the postlaunch commands to the vehicle and the vehicle to send back the feedback data necessary to determine its position and, thereby, bearing. The measured bearing to the contact, along with the position data on the vehicle, is used to determine the discrete commands that must be sent to the vehicle. Here, different than the classical beam rider depicted in figure 1, the objective is to provide control such that a point (which is a specified distance in front of the vehicle and along its longitudinal axis) is maintained on the bearing between launcher and contact (see figure 3). Previous work has resulted in the development of a simple, robust fuzzy logic controller,¹ which accomplishes this objective.

This report is an extension of that work and addresses the formulation of a hierarchical fuzzy controller to accommodate the situation where multiple, conflicting goals exist. The multi-goal problem (figure 3) addressed has

- A primary goal that requires the vehicle not enter a specified zone around the bearing line, and
- A secondary goal that requires a point in front of the vehicle be maintained on the bearing line.

No restrictions are placed on either launcher or contact motion. An example of a situation requiring this type of control is for a guided vehicle acoustically searching for a contact. For this situation, it is desired to guide a point that corresponds to good acoustic behavior while maintaining separation from the measured bearing line to prevent contaminating the signal.

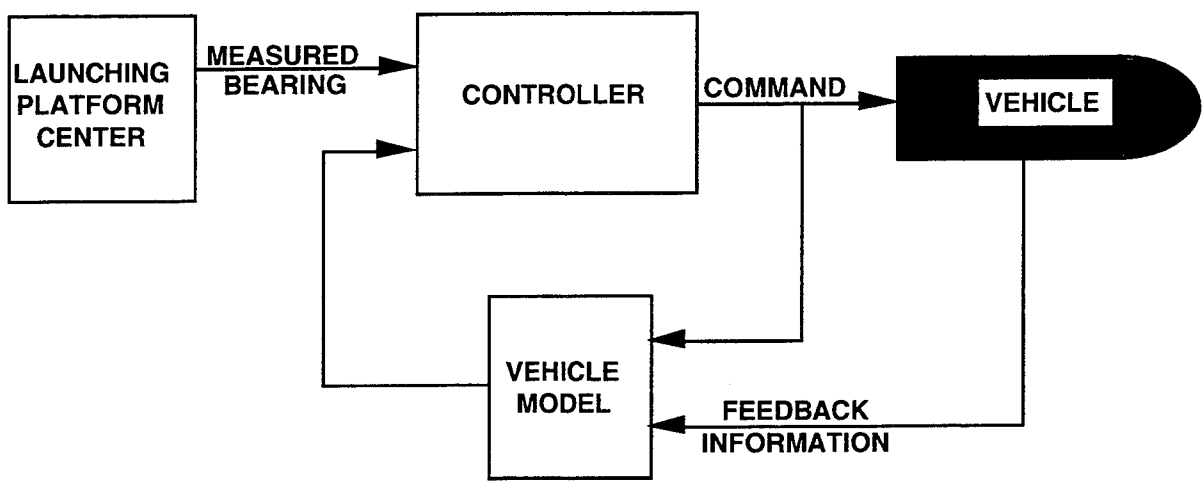

Figure 2. Block Diagram of Overall System

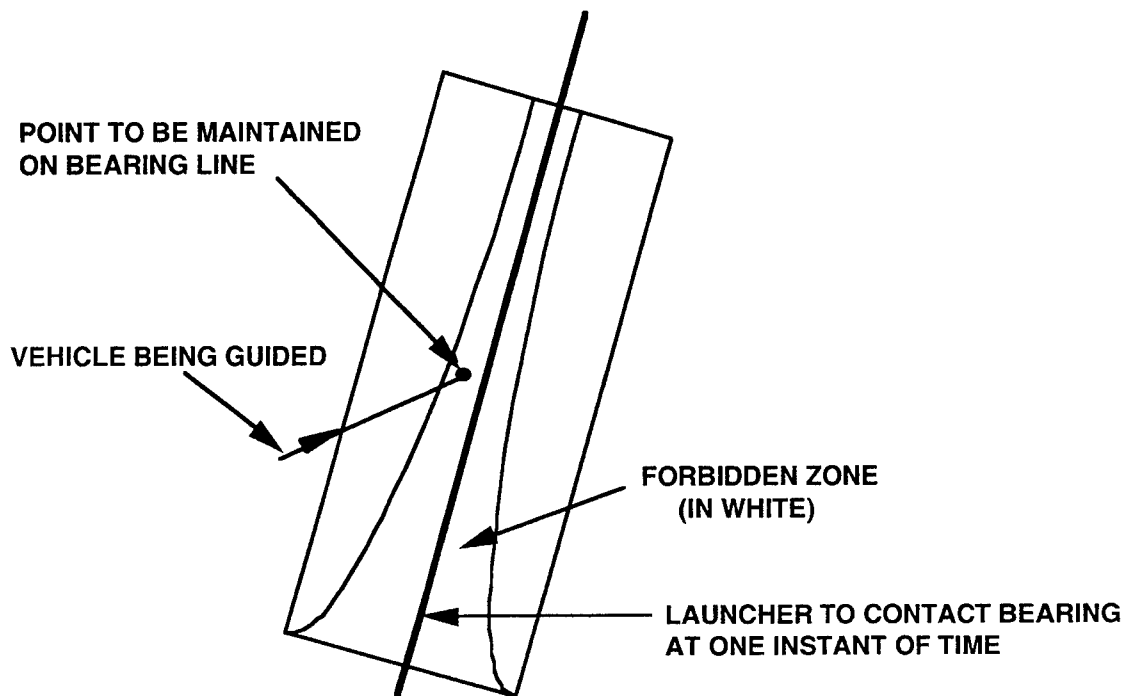

Figure 3. Geometry for Guidance Point Control With Forbidden Zone

2. FORMULATION

2.1 SYSTEM OVERVIEW

The overall system for beam rider control is shown in figures 4 and 5. The sensor subsystem provides the launcher platform position data from its navigational sensors and the contact bearing (B_c), a noisy data stream obtained from its contact sensors. The vehicle model subsystem provides the bearing to both the vehicle (B_v) and its guidance point (B_{gp}). The hierarchical beam rider fuzzy subsystem comprises units shown in figure 5. The forbidden zone unit contains the mathematical function that defines the zone in which vehicle operation is prohibited. The primary and secondary goal error units use both the measured and computed parameters to determine: an error that corresponds to whether or not the vehicle is inside the forbidden zone (e_s), a measure of the rate of change of this error (Δe_s), the error between the contact bearing and the vehicle guidance point bearing (e_{gp}), and the rate of change in error between the vehicle and contact bearing (Δe_v).

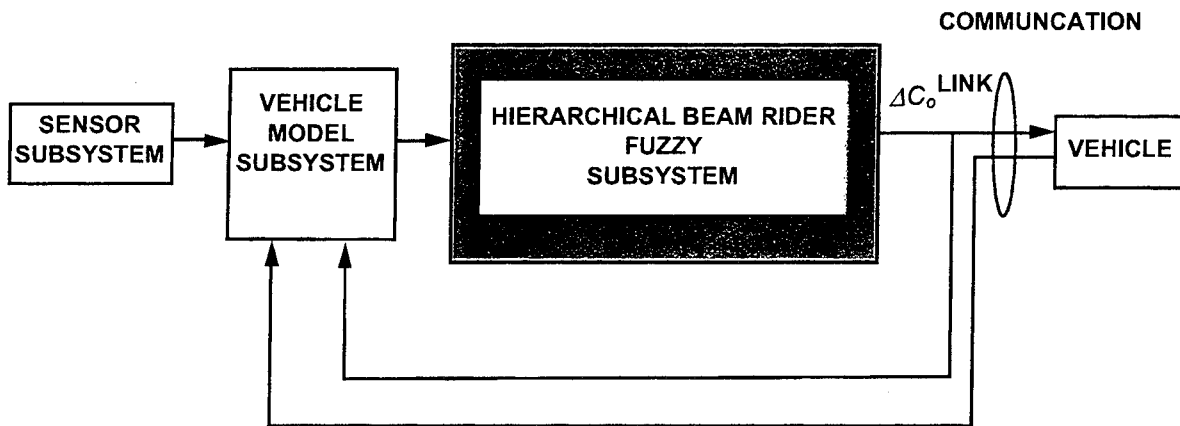

Figure 4. Overall System Structure For Beam Rider Control

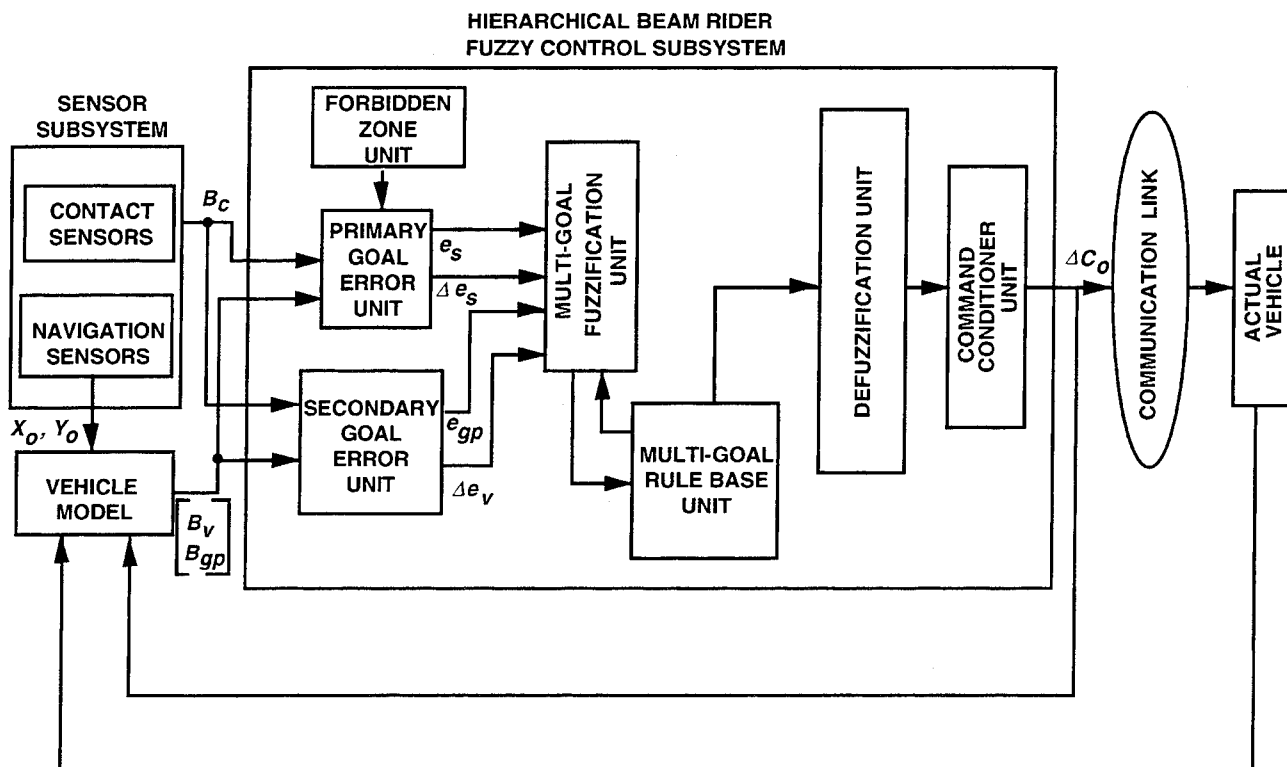

Figure 5. Hierarchical Beam Rider Fuzzy Control System

The multi-goal fuzzification unit uses these crisp variables (e_s , Δe_s , e_{gp} , and Δe_v), along with pre-defined membership functions, to determine fuzzy linguistic variables based on the competing primary and secondary goals. The rule-base unit contains the rule sets for both the primary and secondary goals; these rules use the goal-related linguistic inputs to determine linguistic or fuzzy output commands. The defuzzification unit provides the mechanism for converting fuzzy control output to the crisp control u necessary to achieve the appropriate goal. After defuzzification, the command conditioner unit applies a constraint to u to ensure that a command is never given that would result in a velocity component in the direction of the launching platform at any time during postlaunch control. It also conditions the command as a function of the guidance distance and the range from launcher to vehicle. The resultant command is sent to the vehicle via the wire and also to the vehicle model where together with the vehicle feedback data it is used to update the vehicle kinematic parameters.

2.2 HIERARCHICAL BEAM RIDER FUZZY CONTROL SUBSYSTEM

The functional elements comprising the hierarchical beam rider fuzzy control system are: the forbidden zone unit, primary goal error unit, secondary goal error unit, multi-goal fuzzification unit, multi-goal rule-base unit, defuzzification unit, and the command conditioner unit. A description of each of these units is as follows.

2.2.1 *Forbidden Zone Unit*

In the beam rider problem, it is undesirable to guide a vehicle so as to interfere with the contact information being sensed. In this embodiment, this common problem is addressed through the definition of what is referred to as a forbidden zone. Because the desirable/undesirable position of the vehicle changes as a function of both vehicle range and contact motion, the zone defined herein is an angular separation that is a function of vehicle range and is applied relative to the contact bearing. This can be written as

$$\theta_s = \theta_m e^{-r/c},$$

where

$$\begin{aligned} \theta_m &= \text{maximum angular separation,} \\ r &= \text{range from launcher to vehicle, and} \\ c &= \text{constant.} \end{aligned}$$

Although this is the forbidden zone model used in the simulation runs made herein, other models could also be used.

2.2.2 Primary Goal Error Unit

The primary goal established is the requirement that the vehicle not enter the predefined region. The variables associated with this goal are defined as

$$x1 = e_s = |B_v - B_c| - \theta_s,$$
$$x2 = \Delta e_s = |e_s|_k - |e_s|_{k-1},$$

where $x1$ represents the angular measure of the amount that the vehicle is inside or outside the forbidden zone and $x2$ is a measure of the rate of change of $x1$. Note, the following fuzzy control was derived for $-90 \leq B_v \leq 90$ and $-90 \leq B_c \leq 90$.

2.2.3 Secondary Goal Error Unit

The secondary goal consists of the requirement to maintain the guidance point on the contact bearing.¹ Characterization of this goal is accomplished using the variables

$$x3 = e_{gp} = B_{gp} - B_c,$$
$$x4 = \Delta e_v = |B_v - B_c|_k - |B_v - B_c|_{k-1},$$

where $x3$ is the error associated with maintaining the guidance point on the contact bearing line, and $x4$ is a measure of the change in angle between the vehicle bearing and the contact bearing.

2.2.4 Multi-Goal Fuzzification Unit

The multi-goal fuzzification unit takes crisp inputs and encodes them into fuzzy sets based on competing primary and secondary goals. Encoding of the system inputs requires mapping crisp numerical measurements into fuzzy set representations^{2,3} or linguistic variables. The universes of discourse for primary goal variables $x1$ and $x2$ comprise three linguistic variables (defined by the following term sets).

$$T(x1) = (T^1_{x1}, T^2_{x1}, T^3_{x1}) = (N, Z, P),$$
$$T(x2) = (T^1_{x2}, T^2_{x2}, T^3_{x2}) = (N, Z, P),$$

where N - Negative, Z - Zero, P - Positive .

The universes of discourse for secondary goal variables x_3 and x_4 comprise the seven and five linguistic variables, respectively, defined by the following term sets:

$$T(x_3) = (T^1_{x_3}, T^2_{x_3}, T^3_{x_3}, T^4_{x_3}, T^5_{x_3}, T^6_{x_3}, T^7_{x_3}) = (NL, NM, NS, ZE, PS, PM, PL),$$

$$T(x_4) = (T^1_{x_4}, T^2_{x_4}, T^3_{x_4}, T^4_{x_4}, T^5_{x_4}) = (NL, NS, ZE, PS, PL),$$

where NL - Negative Large, NM - Negative Medium, NS - Negative Small
 ZE - Zero, PS - Positive Small, PM - Positive Medium, and PL - Positive Large.

For the primary goal, the set of membership functions $\mu(x_1)$ corresponding to x_1 and the set of membership functions $\mu(x_2)$ corresponding to x_2 are

$$\mu(x_1) = (\mu^1_{x_1}, \mu^2_{x_1}, \mu^3_{x_1}),$$

$$\mu(x_2) = (\mu^1_{x_2}, \mu^2_{x_2}, \mu^3_{x_2}),$$

and are graphically depicted in figure 6 (a) and (b), respectively, and are given by the following equations:

for $j=1$ and $i=2$,

for $j=2$ and $i=2$,

$$\mu^i_{x_j} = 1 - (|x_j - C^i_{x_j}|) / \delta^i_{x_j}$$

$$\text{for } C^i_{x_j} - \delta^i_{x_j} \leq x_j \leq C^i_{x_j} + \delta^i_{x_j},$$

$$\mu^i_{x_j} = 0$$

$$\text{for } C^i_{x_j} - \delta^i_{x_j} > x_j > C^i_{x_j} + \delta^i_{x_j},$$

for $j=1$ and $i=1$,

for $j=2$ and $i=1,3$,

$$\mu^i_{x_j} = 1 - (|x_j - C^i_{x_j}|) / \delta^i_{x_j}$$

$$\text{for } a^i C^i_{x_j} \geq a^i x_j \geq a^i (C^i_{x_j} - a^i \delta^i_{x_j}),$$

$$\mu^i_{x_j} = 1$$

$$\text{for } a^i C^i_{x_j} < a^i x_j,$$

$$\mu^i_{x_j} = 0$$

$$\text{for } a^i (C^i_{x_j} - a^i \delta^i_{x_j}) > a^i x_j,$$

where $a^i = 1$, except for $i=1$ where $a^1 = -1$;

for $j=1$ and $i=3$,

$$\mu^i_{x_j} = 1$$

$$\text{for } C^i_{x_j} \leq x_j,$$

$$\mu^i_{x_j} = 0$$

$$\text{for } C^i_{x_j} > x_j.$$

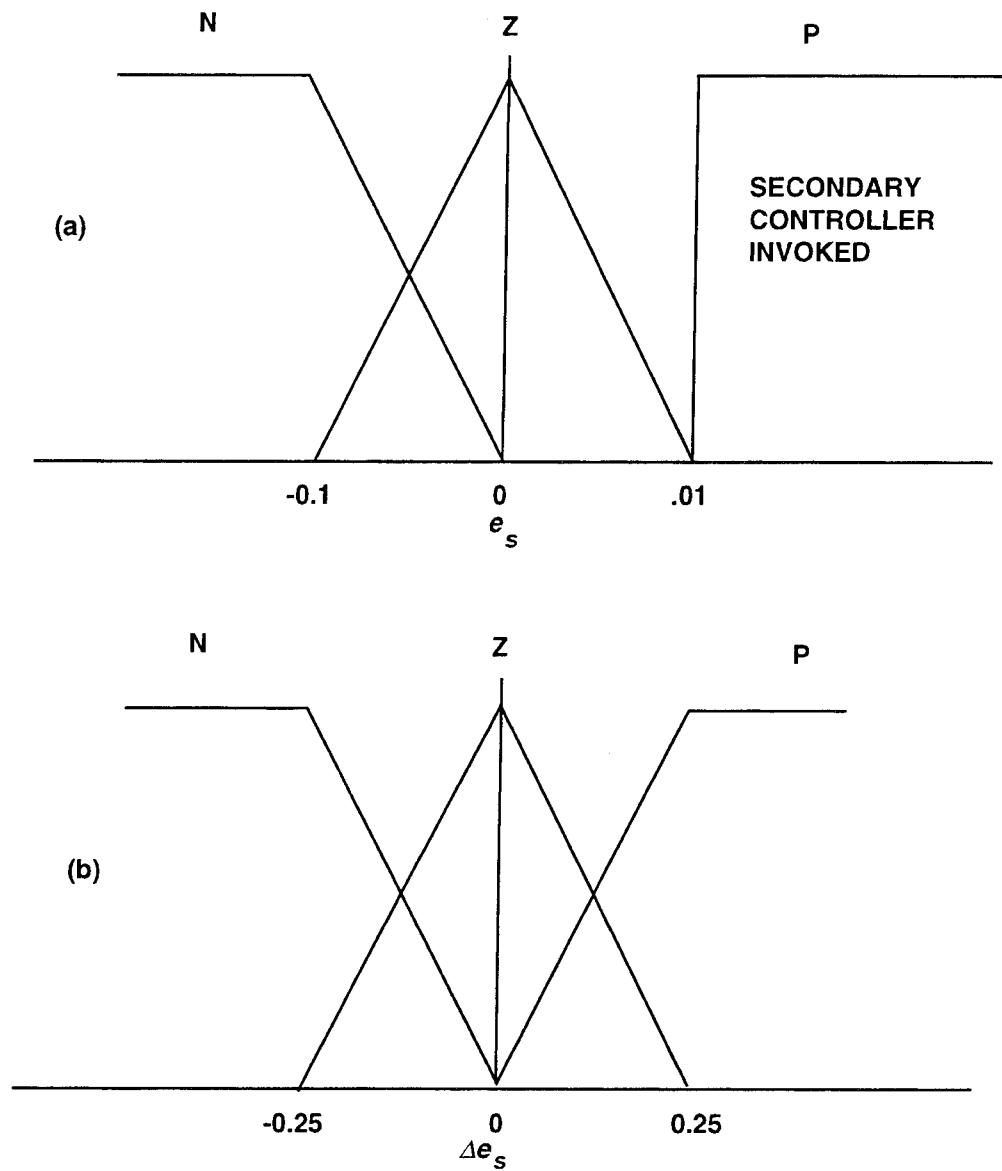

Figure 6. Graphical Representation of the Membership Functions for the Fuzzy Inputs for Primary Goal

The set of membership functions $\mu(x_3)$ corresponding to x_3 and the set of membership functions $\mu(x_4)$ corresponding to x_4 are

$$\mu(x_3) = (\mu^1_{x_3}, \mu^2_{x_3}, \mu^3_{x_3}, \mu^4_{x_3}, \mu^5_{x_3}, \mu^6_{x_3}, \mu^7_{x_3}),$$

$$\mu(x_4) = (\mu^1_{x_4}, \mu^2_{x_4}, \mu^3_{x_4}, \mu^4_{x_4}, \mu^5_{x_4}),$$

and are depicted in figure 7 (a) and (b), respectively, and are given by the following equations:

for $j = 3$ and $i = 2,3,4,5,6$,
for $j = 4$ and $i = 2,3,4$,

$$\begin{aligned} \mu_{xj}^i &= 1 - (|xj - C_{xj}^i|) / \delta_{xj}^i && \text{for } C_{xj}^i - \delta_{xj}^i \leq xj \leq C_{xj}^i + \delta_{xj}^i , \\ \mu_{xj}^i &= 0 && \text{for } C_{xj}^i - \delta_{xj}^i > xj > C_{xj}^i + \delta_{xj}^i , \end{aligned}$$

for $j = 3$ and $i = 1,7$,
for $j = 4$ and $i = 1,5$,

$$\begin{aligned} \mu_{xj}^i &= 1 - (|xj - C_{xj}^i|) / \delta_{xj}^i && \text{for } a^i C_{xj}^i \geq a^i xj \geq a^i (C_{xj}^i - a^i \delta_{xj}^i) , \\ \mu_{xj}^i &= 1 && \text{for } a^i C_{xj}^i < a^i xj , \\ \mu_{xj}^i &= 0 && \text{for } a^i (C_{xj}^i - a^i \delta_{xj}^i) > a^i xj , \end{aligned}$$

where $a^i = 1$, except for $i = 1$ where $a^i = -1$.

The system output variable or control variable is the vehicle course command (ΔC) and the universe of discourse for ΔC comprises the seven linguistic variables defined by the following term set:

$$T(\Delta C) = (T^1_{\Delta C}, T^2_{\Delta C}, T^3_{\Delta C}, T^4_{\Delta C}, T^5_{\Delta C}, T^6_{\Delta C}, T^7_{\Delta C}) = (NL, NM, NS, ZE, PS, PM, PL) .$$

The set of membership functions $\mu(\Delta C)$ corresponding to output ΔC ,

$$\mu(\Delta C) = (\mu^1_{\Delta C}, \mu^2_{\Delta C}, \mu^3_{\Delta C}, \mu^4_{\Delta C}, \mu^5_{\Delta C}, \mu^6_{\Delta C}, \mu^7_{\Delta C}) ,$$

is depicted in figure 7(c) and given by the following equations:

for $i = 1,2,3,4,5,6,7$,

$$\begin{aligned} \mu_{\Delta C}^i &= 1 - (|\Delta C - C_{\Delta C}^i|) / \delta_{\Delta C}^i && \text{for } C_{\Delta C}^i - \delta_{\Delta C}^i \leq \Delta C \leq C_{\Delta C}^i + \delta_{\Delta C}^i , \\ \mu_{\Delta C}^i &= 0 && \text{for } C_{\Delta C}^i - \delta_{\Delta C}^i > \Delta C > C_{\Delta C}^i + \delta_{\Delta C}^i . \end{aligned}$$

The values of the membership equation constants C and δ are given in tables 1 and 2.

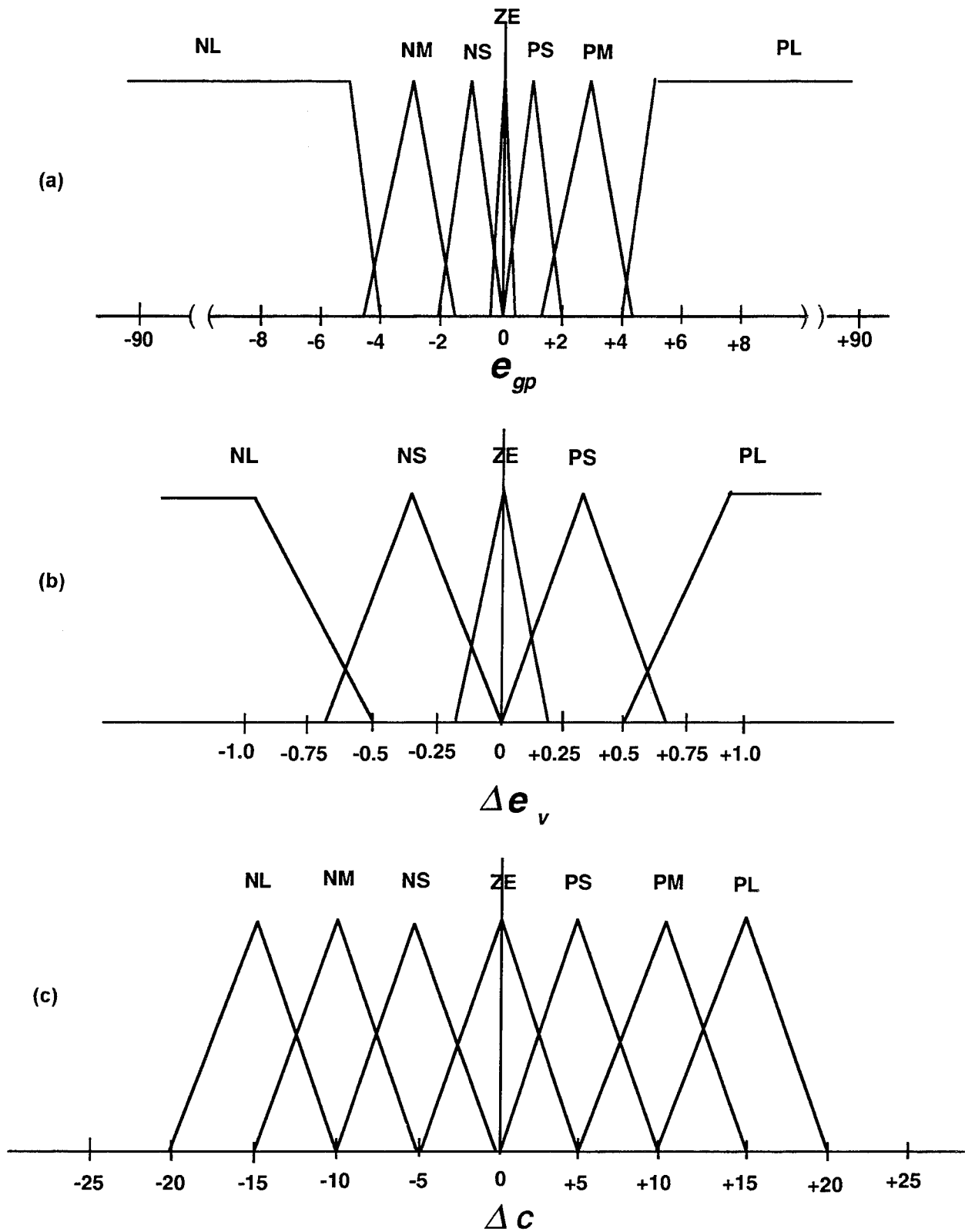

Figure 7. Graphical Representation of the Membership Functions for the Fuzzy Inputs for the Secondary Goal and Output Control Set

Table 1. C and δ Constants for Primary Goal Membership Functions

i	$\mu(x1)$		$\mu(x2)$	
	C^i_{x1}	δ^i_{x1}	C^i_{x2}	δ^i_{x2}
1	-0.1	.01	-0.25	0.25
2	0	.01	0	0.25
3	+0.1	--	0.25	0.25

Table 2. C and δ Constants for Secondary Goal and Output Membership Functions

i	$\mu(x3)$		$\mu(x4)$		$\mu(\Delta C)$	
	C^i_{x3}	δ^i_{x3}	C^i_{x4}	δ^i_{x4}	$C^i_{\Delta C}$	$\delta^i_{\Delta C}$
1	-5.0	1.0	-0.95	0.45	-15.0	5.0
2	-3.0	1.5	-0.3375	0.3375	-10.0	5.0
3	-1.0	1.0	0.0	0.1875	-5.0	5.0
4	0.0	0.4	0.3375	0.3375	0.0	5.0
5	1.0	1.0	0.95	0.45	5.0	5.0
6	3.0	1.5	--	--	10.0	5.0
7	5.0	1.0	--	--	15.0	5.0

2.2.5 Multi-Goal Rule-Base Unit

Figure 8 is a depiction of the multi-goal fuzzy rule-base unit that consists of the heuristic relationships (i.e., IF THEN rules) between the fuzzy inputs and outputs and fuzzy implication operations.

The rule section comprises two sections: one corresponding to the primary goal and the other corresponding to the secondary goal. This rule-base unit selects from either the primary goal rule set or secondary goal rule set, depending on whether the vehicle enters/approaches the forbidden zone or is reasonably displaced from this zone. The matrices of figure 9 define the heuristic relationships necessary to accomplish the primary goal. Each entry in these matrices

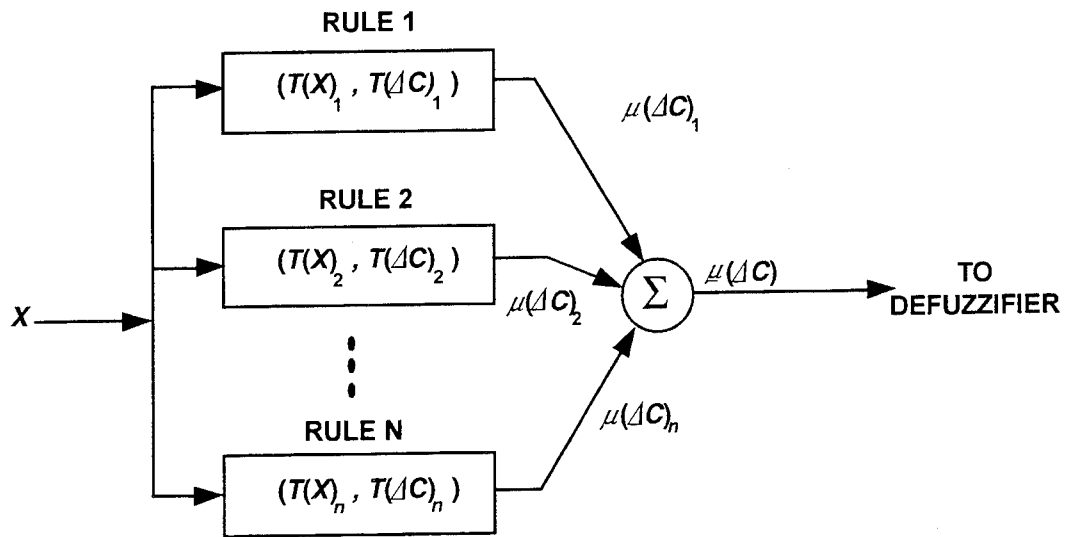

Figure 8. Multi-Goal Rule-Base Unit

		e_s		
		N	Z	P
Δe_s	N	PS	PS	-
	Z	PM	ZE	-
	P	PL	ZE	-

$B_V - B_C > 0$

		e_s		
		N	Z	P
Δe_s	N	NS	NS	-
	Z	NM	ZE	-
	P	NL	ZE	-

$B_V - B_C > 0$

Figure 9. Matrices for Primary Goal in Rule-Base Unit

corresponds to a rule and defines the input output relationships between the fuzzy variables; for example, the rule defined by the entry in the first row and first column of the first matrix is

IF e_s is *N* **AND** Δe_v is *N* **AND** $(B_v - B_c)$ is positive **THEN** ΔC is *PS*.

The matrices of figure 10 define those rules necessary to accomplish the second objective and are of a similar form:

IF e_s is *P* **AND** e_{gp} is *NL* **AND** Δe_v is *NL* **AND** $(B_v - B_c)$ is positive **THEN** ΔC is *PL* .

It is in this unit where the hierarchical structure of the controller is established. Here, it is observed that the rules pertaining to the secondary goal are all conditioned on the premise that the vehicle is reasonably displaced outside the forbidden zone, i.e., $e_s > 0.01$. The generation of these matrices did not require a mathematical description of system dynamics but rather intuitive knowledge of system behavior.

		e_{gp}						
		NL	NM	NS	ZE	PS	PM	PL
Δe_v	NL	PL	PL	PL	PS	ZE	NM	NL
	NS	PL	PM	PS	ZE	NS	NM	NL
	ZE	PL	PM	PS	ZE	NS	NM	NL
	PS	PL	PM	PS	NS	NM	NL	NL
	PL	PL	PS	ZE	NS	NL	NL	NL

* $B_v - B_c > 0$

		e_{gp}						
		NL	NM	NS	ZE	PS	PM	PL
Δe_v	NL	PL	PM	ZE	NS	NL	NL	NL
	NS	PL	PM	PS	ZE	NS	NM	NL
	ZE	PL	PM	PS	ZE	NS	NM	NL
	PS	PL	PL	PM	PS	NS	NM	NL
	PL	PL	PL	PL	PS	ZE	NS	NL

* $B_v - B_c < 0$

Figure 10. Matrices for Secondary Goal in Rule-Base Unit

For each fuzzy rule that is fired, there is a fuzzy implication and an associated fuzzy implication function. The determination of the fuzzy implication functions is explained through the use of an example. Assume the following rules in the second primary goal matrix are fired:

1. **IF** x_1 is $T^2_{x_1}$ **AND** x_2 is $T^2_{x_2}$ **THEN** ΔC is $T^4_{\Delta C}$,
2. **IF** x_1 is $T^2_{x_1}$ **AND** x_2 is $T^1_{x_2}$ **THEN** ΔC is $T^3_{\Delta C}$.
3. **IF** x_1 is $T^1_{x_1}$ **AND** x_2 is $T^2_{x_2}$ **THEN** ΔC is $T^2_{\Delta C}$,
4. **IF** x_1 is $T^1_{x_1}$ **AND** x_2 is $T^1_{x_2}$ **THEN** ΔC is $T^3_{\Delta C}$.

The numerical strength of the output of rules 1 and 2 can be expressed, respectively, as

$$\begin{aligned}\xi_{(1)} &= y^2_{x_1} \wedge y^2_{x_2} = \min(y^2_{x_1}, y^2_{x_2}), \\ \xi_{(2)} &= y^2_{x_1} \wedge y^1_{x_2} = \min(y^2_{x_1}, y^1_{x_2}), \\ \xi_{(3)} &= y^1_{x_1} \wedge y^2_{x_2} = \min(y^1_{x_1}, y^2_{x_2}), \\ \xi_{(4)} &= y^1_{x_1} \wedge y^1_{x_2} = \min(y^1_{x_1}, y^1_{x_2}),\end{aligned}$$

where

$y^i_{x_j}$ is $\mu^i_{x_j}$ evaluated at a specific value of $x_j(t)$ at time t , and \wedge denotes fuzzy 'and'.

The inferred output control function from the first rule is $\xi_{(1)}\mu^4_{\Delta C}$, the inferred function from the second rule is $\xi_{(2)}\mu^3_{\Delta C}$, the inferred function from the third rule is $\xi_{(3)}\mu^2_{\Delta C}$, and the inferred function from the fourth rule is $\xi_{(4)}\mu^3_{\Delta C}$,

where

$\xi_{(1)}\mu^4_{\Delta C} = \mu(\Delta C)_{(1)}$ = the output control function for rule 1 defined by $\mu^4_{\Delta C}$ multiplied by the value $\xi_{(1)}$;

$\xi_{(2)}\mu^3_{\Delta C} = \mu(\Delta C)_{(2)}$ = the output control function for rule 2 defined by $\mu^3_{\Delta C}$ multiplied by the value $\xi_{(2)}$;

$\xi_{(3)}\mu^2_{\Delta C} = \mu(\Delta C)_{(3)}$ = the output control function for rule 3, defined by $\mu^2_{\Delta C}$ multiplied by the value $\xi_{(3)}$; and

$\xi_{(4)}\mu^3_{\Delta C} = \mu(\Delta C)_{(4)}$ = the output control function for rule 4, defined by $\mu^3_{\Delta C}$ multiplied by the value $\xi_{(4)}$.

2.2.6 Defuzzification Unit

The defuzzification unit takes the fuzzy outputs from the multi-goal rule-base unit and decodes them into a crisp output that is acceptable for use in vehicle control. This unit employs a strategy that maps fuzzy control actions defined over an output universe of discourse (see figure 7c) into a space of crisp control actions (i.e., course commands). The method of defuzzification used in this application is the centroid method.⁴ The centroid of the composite function is used as the crisp control value and is computed as follows:

$$\Delta C = \sum_k \left\{ \left(\xi_{(k)} C_{\Delta C(k)} \right) I_{\Delta C(k)} \right\} / \sum_k \xi_{(k)} I_{\Delta C(k)},$$

where \sum_k indicates summation over all the rules fired.

$I_{\Delta C(k)}$ and $C_{\Delta C(k)}$ are defined as the respective area and centroid of the k th rule consequent set membership function.

2.2.7 Command Conditioner Unit

Command conditioning deals with two types of modifications that are made to the commands generated by the defuzzification process.

The first type is related to ensuring the safety of the launching platform and is applied during both primary and secondary control. The control commands coming from the defuzzification unit are interrogated to determine if these commands exceed limits that are governed by the tactical situation. Figure 12 is a graphical representation of this portion of the unit and the value of the vehicle course command limits (L_1 and L_2) are defined, assuming there is no initial vehicle velocity component toward the firing vessel, as follows:

$$L_1 = B_v + 90^\circ - (C_v)_{k-1},$$

$$L_2 = B_v - 90^\circ - (C_v)_{k-1},$$

where $(C_v)_{k-1}$ is the vehicle course from the last update cycle. These limits ensure that the trajectory of the vehicle that would result from the addition of the fuzzy control system commands does not have a velocity component in the direction of the firing vessel at any time during postlaunch guidance operation. When the computed command exceeds the limit, only the portion of the command that will result in the vehicle being on a trajectory that is perpendicular to the vehicle bearing line is sent to the weapon. Note, because the course command limits in the constraint unit are dependent on the tactical situation, these limits are determined every update cycle.

Further command conditioning is performed during secondary goal operation only. The modifications that are made to the command during this phase of operation are a function of both the vehicle guidance distance and the range from the launching platform to the vehicle. This empirically obtained gain is expressed as

$$K = f(GD, SV, R) = K_o(SV)R / GD.$$

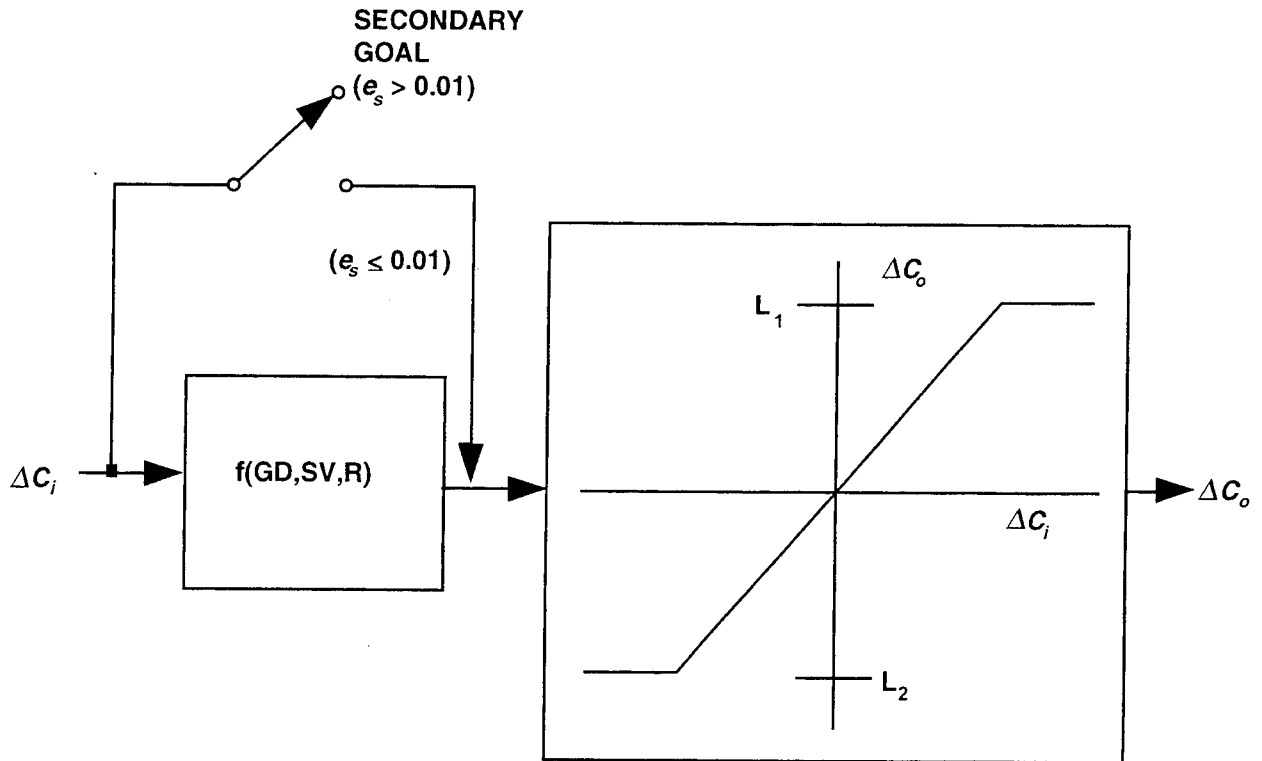

Figure 12. Representation of the Command Conditioning Unit

2.3 SYSTEM OPERATION

In the operation of the hierarchical fuzzy control beam rider system, the contact bearing, the forbidden zone angular separation, and the vehicle bearing are combined to form an error (e_s), which corresponds to whether or not the vehicle is inside the forbidden zone. The absolute value of this error from the previous update cycle is subtracted from the current angle's absolute value to form the change in angle between the vehicle and the forbidden zone (Δe_s). The contact bearing is combined with the vehicle guidance point bearing to form the guidance point bearing error (e_{gp}). The sign of the difference between the contact bearing and vehicle bearing is examined to determine what side of the contact bearing line the vehicle is on (affects rules to be exercised). The absolute value of the angle between the vehicle bearing and the contact bearing from the previous update cycle is subtracted from the current angle's absolute value to form the change in angle between the vehicle bearing and the contact bearing (Δe_v). Based on competing primary and secondary goals, the forbidden zone error and the change in this error are converted from crisp numerical values to fuzzy inputs (linguistic variables) by the multi-goal fuzzification unit, or the vehicle guidance point bearing error and the change in angle between the vehicle

bearing and the contact bearing are converted from crisp numerical values to fuzzy inputs (linguistic variables) by the multi-goal fuzzification unit. Based on the goal-selected inputs and the sign of the angle between the vehicle bearing and the contact bearing, the multigoal fuzzy rule-based unit invokes all the appropriate rules to determine the resultant fuzzy output actions necessary to achieve the appropriate goal. These actions are combined and sent to the defuzzification unit. The composite fuzzy output is converted to a crisp numerical course command and the conditioning unit further interrogates this command to determine what portion of the command, if any, should be issued to the vehicle based on tactical considerations. The conditioned course command output is automatically sent to the actual vehicle over the wire communication link and also provided to update the vehicle model in the SCCS. The process described herein is not a one-time postlaunch activity, but it goes on continually throughout the postlaunch encounter.

3. SIMULATION RESULTS

The hierarchical fuzzy controller is implemented in a computer simulation, which includes the contact model, launching platform model, forbidden zone model, and a model of the vehicle being guided to demonstrate and analyze performance. Transient and steady-state hierarchical control responses are obtained for the cases of stationary and linear contact motion and a comparison is made between hierarchical and non-hierarchical fuzzy control operation. A number of simulation runs were made to examine performance; and selected runs are included in this report to illustrate the salient aspects of the hierarchical controller.

An example trajectory for hierarchical fuzzy beam rider operation, where the vehicle is prohibited from entering an angular forbidden zone around the contact bearing line, is shown in figure 13a. For the runs in this report, the vehicle is launched on either a plus or minus course of 25° and remains on that course until control begins at 20 seconds into the run. In figure 13a, the launcher and contact are both on 90° courses and traveling at the same velocity. The vehicle is within the forbidden zone when control is initiated; the hierarchical controller activates primary control and steers the vehicle out of the forbidden zone (i.e., away from the bearing line). As soon as the vehicle exits the forbidden zone, secondary control is activated and the vehicle is turned toward the bearing line to place the vehicle guidance point within the proximity of the contact bearing line. In this example, when the vehicle guidance point is placed close to the contact bearing line, secondary control can maintain the guidance point close to the bearing line without the vehicle re-entering the forbidden zone. Figure 13b is an example plot of the magnitude of the boundary separation angle relative to the contact bearing line as a function of vehicle range. The particular relationship used in this report was for illustrative purposes. The actual forbidden zone would be derived from empirical data or other *a priori* information.

3.1 HIERARCHICAL VS NON-HIERARCHICAL CONTROL

The plots for run number 1 in figures 14a through 14c illustrate hierarchical fuzzy beam rider operation for linear target motion. In this case, the vehicle is launched to lag the bearing line ($c_w = -25^\circ$). When the vehicle control is activated at 20 seconds, the vehicle is outside the forbidden zone (positive separation error in figure 14a) and secondary control is activated. The bearing error between the vehicle guidance point and contact bearings (figure 14b) is negative and positive course commands are required to place the guidance point near the contact bearing line. Because the initial firing course places the vehicle in an opening situation, the separation error increases at first (for 5 seconds) until the vehicle is oriented to close on the boundary of the forbidden zone. At 45 seconds into the run, the guidance point is within the vicinity of the contact bearing line (near zero bearing error in figure 14b) and remains close (bearing error approximately zero) until the vehicle crosses the boundary of the forbidden zone (i.e., the slightly negative separation error at 56 seconds). At this point the fuzzy primary controller supersedes secondary control and commands the vehicle to stay outside the forbidden zone (i.e., keep the separation error positive).

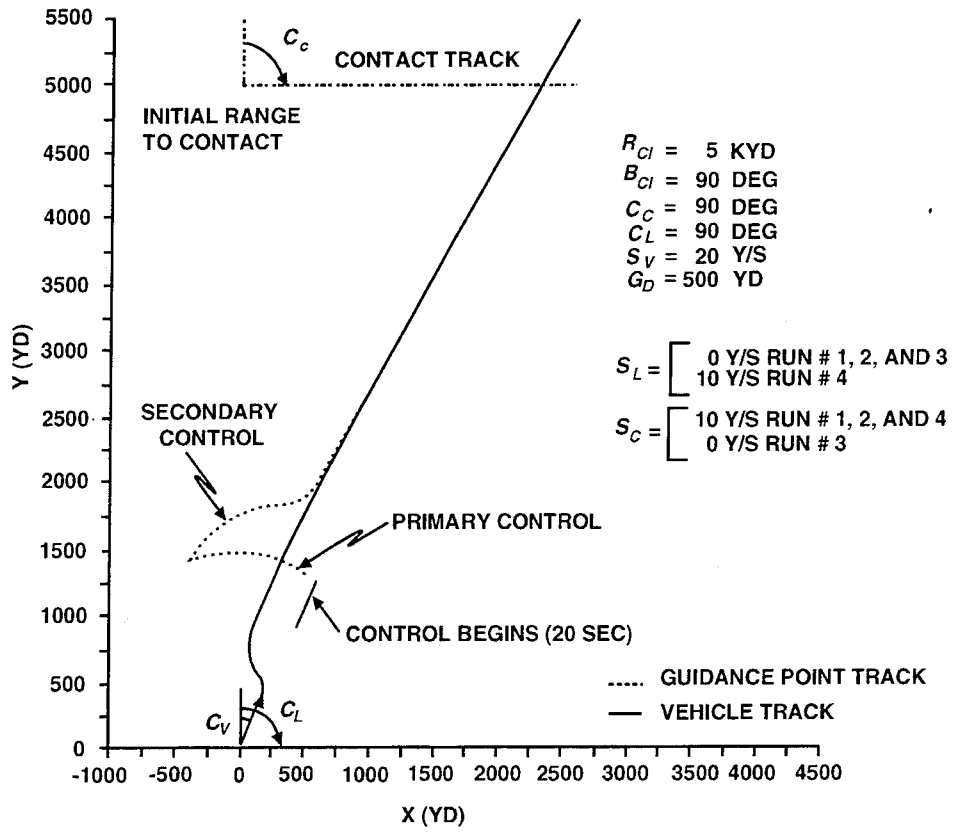

Figure 13a. Example of Hierarchical Fuzzy Beam Rider Trajectory

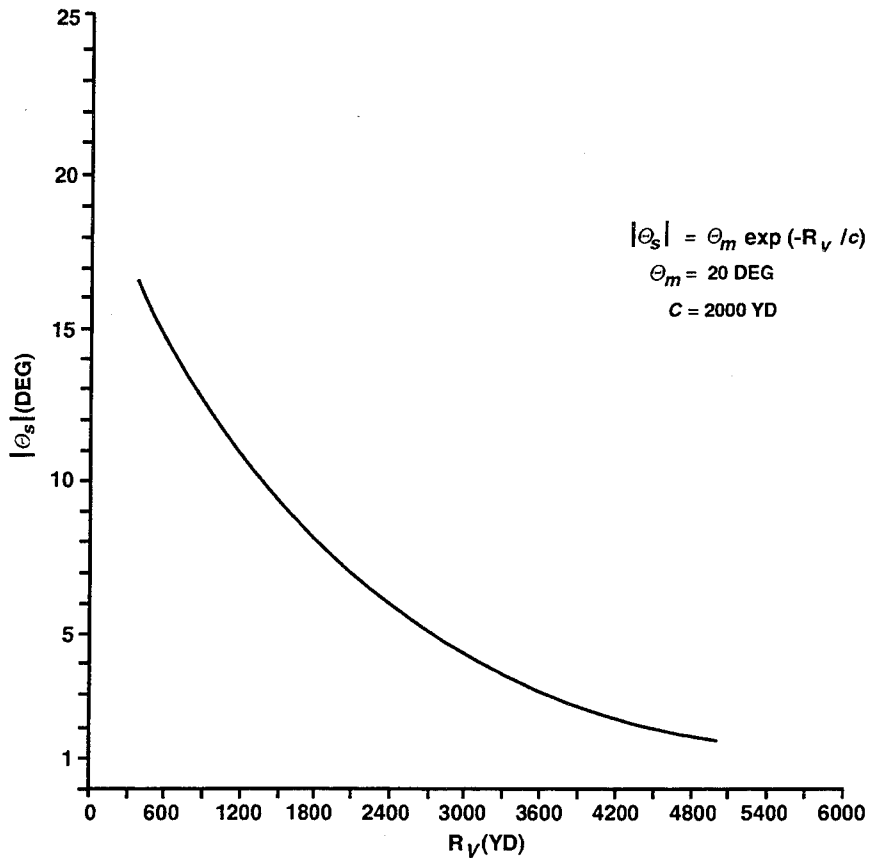

Figure 13b. Separation Angle vs Vehicle Range

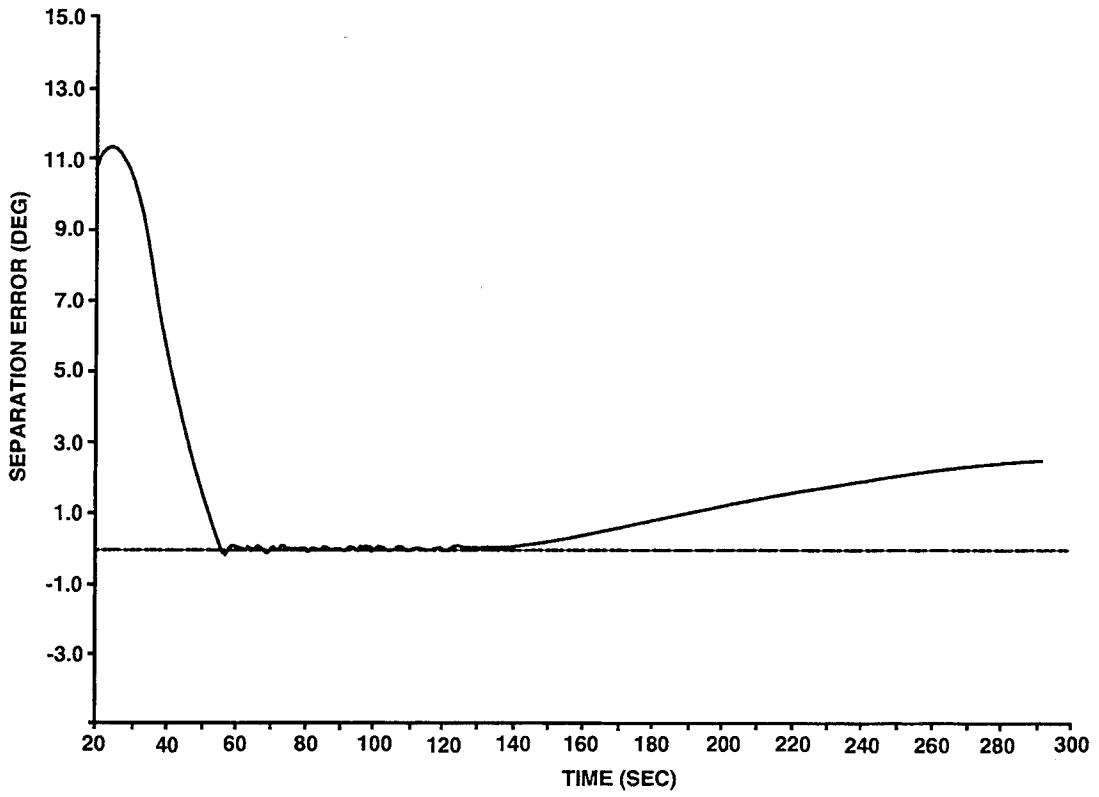

Figure 14a. Boundary Separation Error for Run Number 1

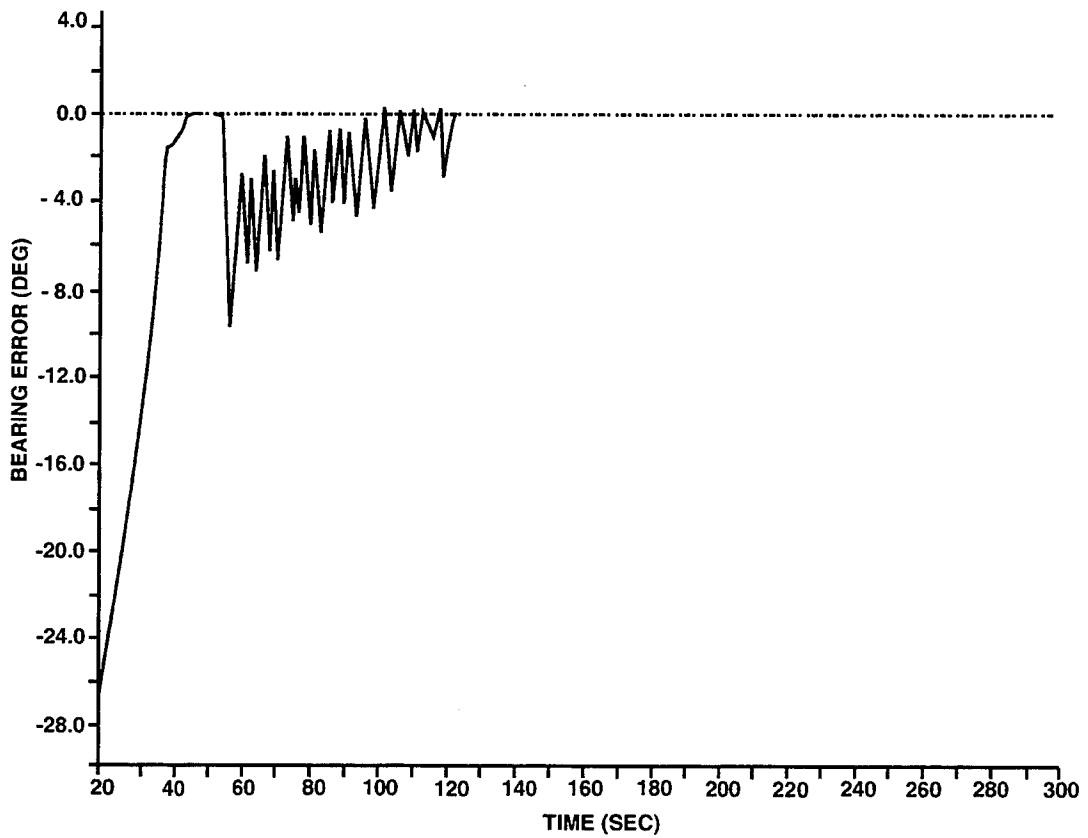

Figure 14b. Guidance Point Bearing Error for Run Number 1

Because the result of primary control is to take the vehicle outside the forbidden zone, the guidance point bearing error increases. Thus, for the next 65 seconds, the hierarchical controller switches between primary control and secondary control. This switching causes the boundary separation error to oscillate around zero and the guidance point bearing error to oscillate toward zero in an exponential decaying fashion. This decaying behavior in the guidance point bearing error is a result of the exponentially decreasing boundary separation angle with increasing vehicle range.

At 121 seconds, the magnitude of the forbidden zone angle, the orientation of the vehicle, and the guidance distance are such that the guidance point is maintained in the vicinity of the contact bearing line (i.e., bearing error near zero) while the vehicle remains outside the forbidden region (i.e., separation error is always positive). Because the magnitude of the boundary separation angle continues to decrease as the vehicle range increases with time, the separation error increases for the remainder of the run. Figure 14c shows the trajectories of the contact, vehicle, and vehicle guidance point. Note, the chattering behavior of the guidance point during the portion of the run where the hierarchical fuzzy controller switches between primary and secondary control to satisfy the conflicting guidance criteria.

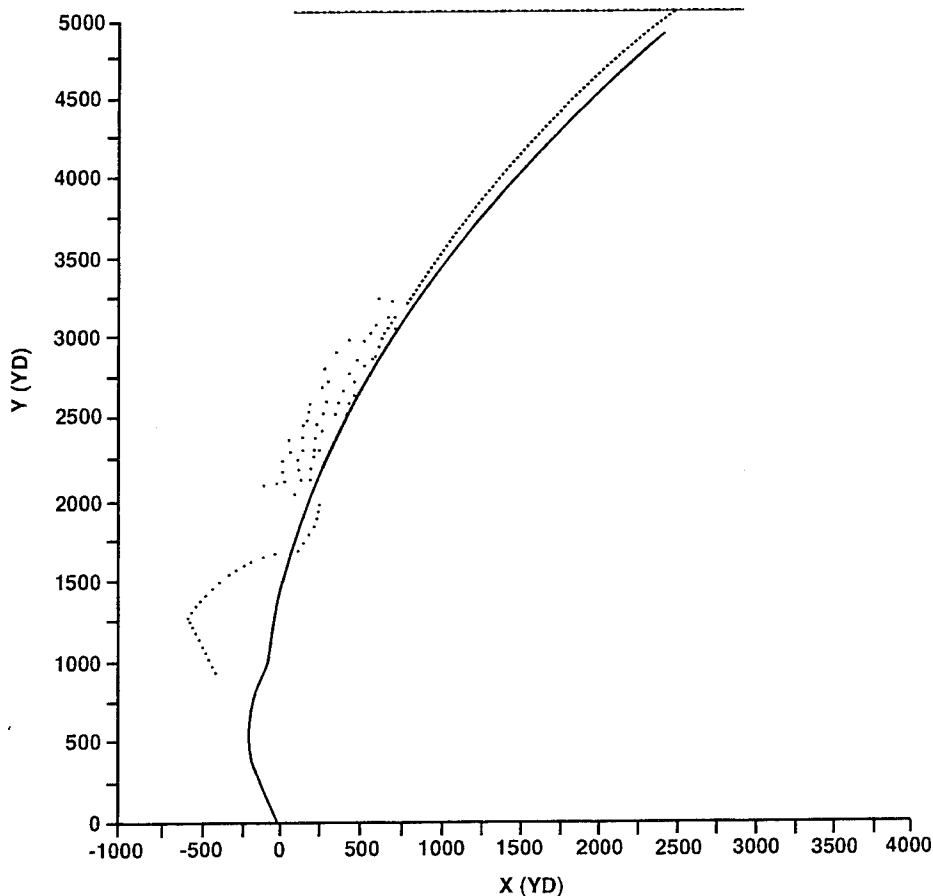

Figure 14c. Hierarchical Beam Rider Trajectory for Run Number 1

The plots for run number 2 in figures 15a through 15c show simple fuzzy controller operation (i.e., secondary control only). In figures 15a and 15b, the error behavior is exactly the same as figures 14a and 14b for the first 56 seconds because the vehicles in both cases are under secondary control. When the vehicle crosses into the forbidden zone at 56 seconds, the angular separation error becomes negative and remains negative until 165 seconds. In figure 15b, similar to figure 14b in run number 1, the bearing error for the vehicle guidance point has decreased to approximately zero at 45 seconds indicating the guidance point is placed within the vicinity of the contact bearing line. The fuzzy controller has no problem keeping the guidance point near the bearing line for the remainder of the run. The resultant plots in figures 15a through 15c show excellent transient and steady-state responses and a smooth trajectory behavior for the entire run. The negative separation error in figure 15a from 56 seconds to 165 seconds indicates the vehicle is operating inside the forbidden zone during this time interval. While the guidance response is excellent, the contact bearing measured by the launcher sensor could be contaminated due to forbidden zone vehicle operation.

Finally, after 165 seconds, the bearing separation error goes positive and remains positive for the remainder of the run. This is due to the magnitude of the forbidden zone angle, the orientation of the vehicle, and the guidance distance are such that the guidance point can be maintained in the vicinity of the contact bearing line and the vehicle can remain outside the forbidden region.

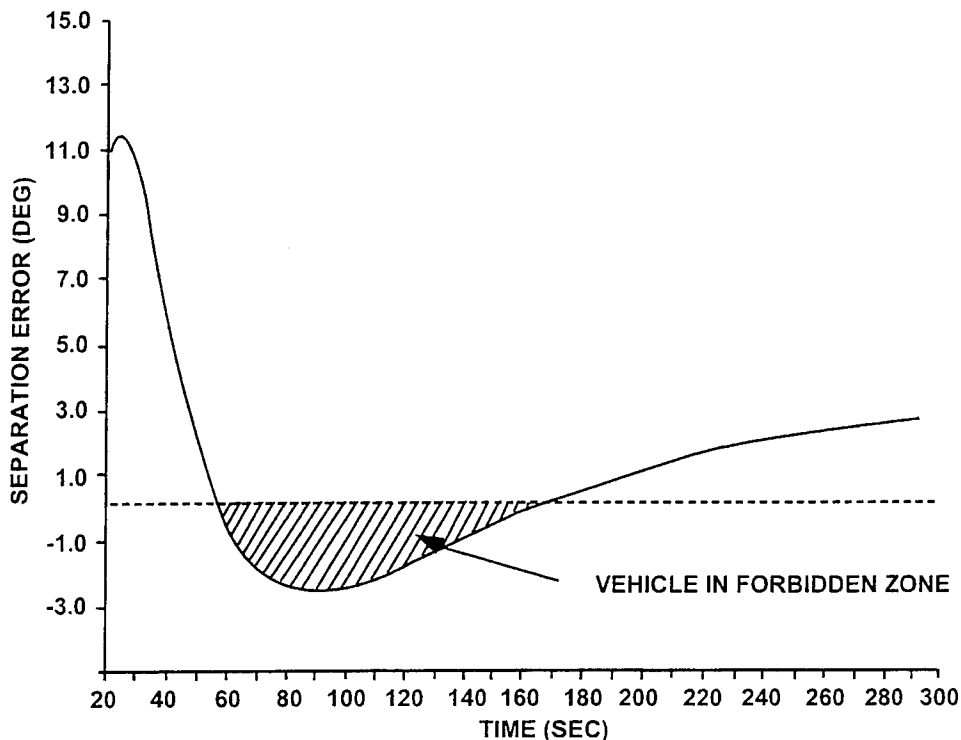

Figure 15a. Boundary Separation Error for Run Number 2

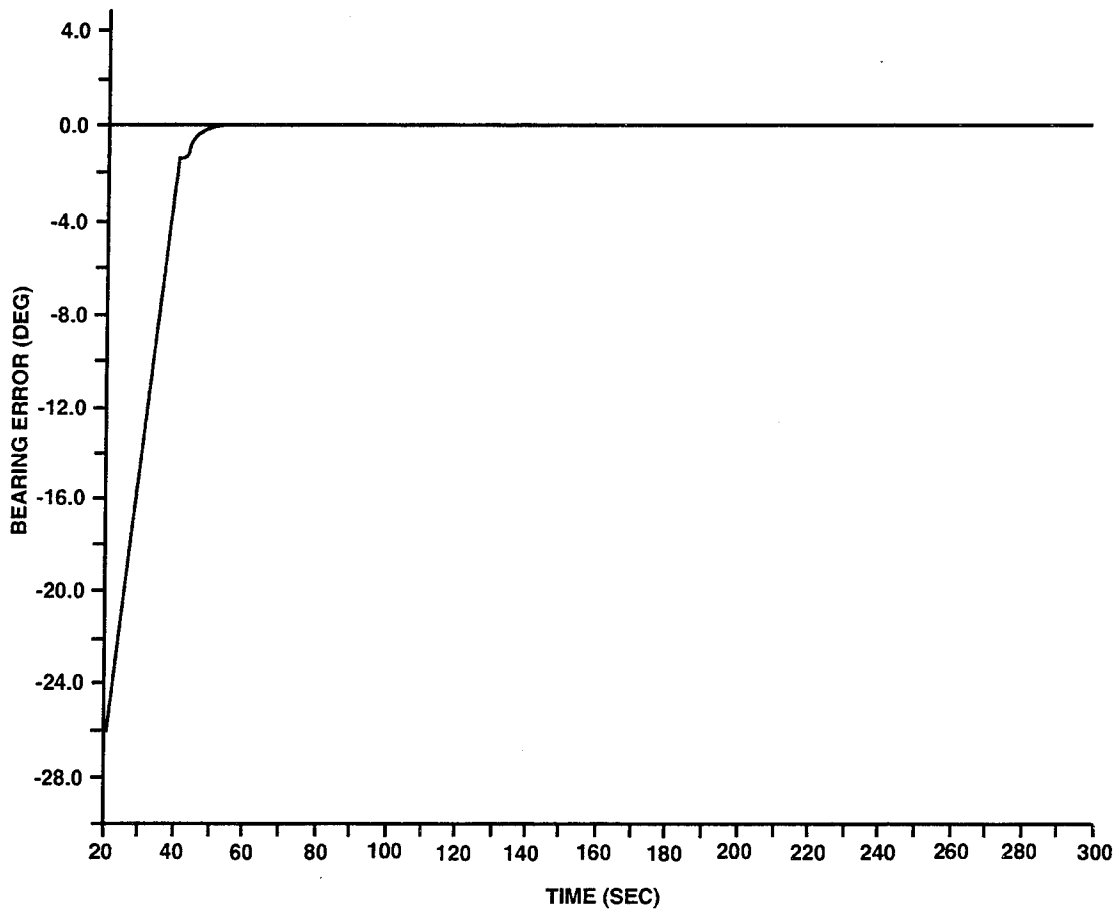

Figure 15b. Guidance Point Bearing Error for Run Number 2

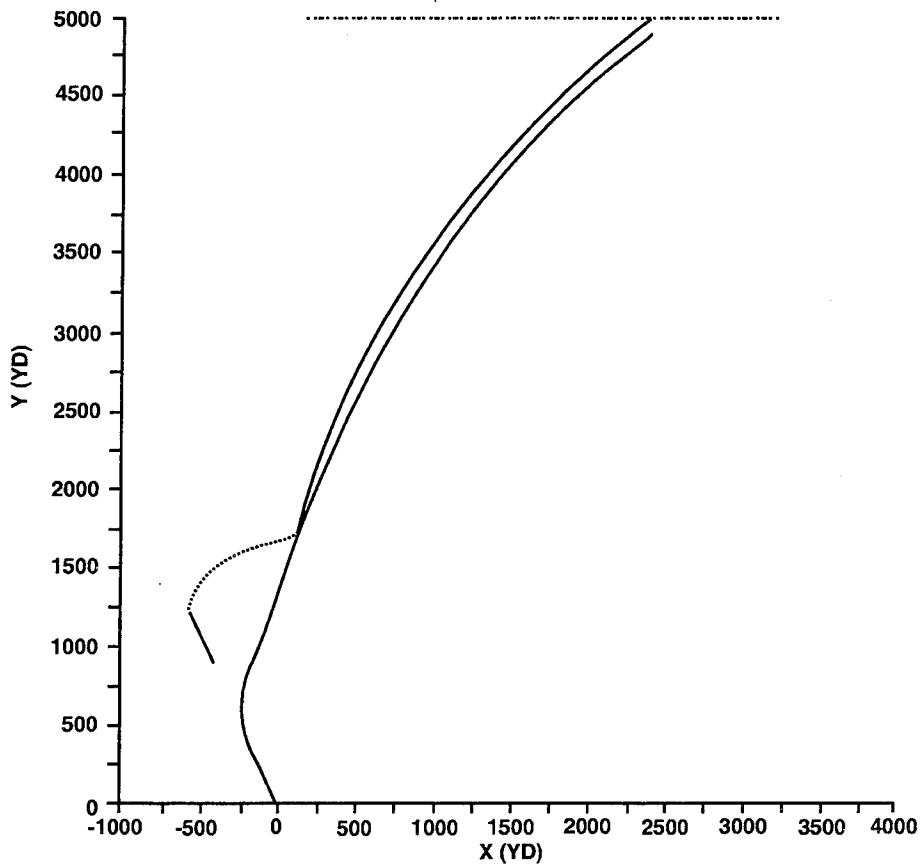

Figure 15c. Beam Rider Trajectory for Run Number 2

3.2 STATIONARY BEARING INPUT

In run number 3, the contact and launcher remain stationary throughout the run, and the vehicle is launched on a course of 25° . When control is initiated, the vehicle is outside the forbidden region as shown by the large positive separation error in figure 16a. The hierarchical fuzzy controller selects secondary control and negative course commands are issued (positive bearing error in figure 16b) to bring the guidance point to the bearing line. At 44 seconds, the vehicle crosses the forbidden zone boundary and the controller switches to primary control and issues the course commands to return the vehicle outside this zone. The initial launch trajectory and size of the boundary separation angle produce a vehicle closing geometry that causes the separation error to overshoot and penetrate the forbidden zone. At 48 seconds, the vehicle exits the forbidden region (positive separation error in figure 16a), and the hierarchical controller returns to secondary control to issue commands to reduce the guidance-point error to zero. The switching between primary and secondary control continues for the remainder of the run.

The initial separation caused by the firing course results in large error transients for both the separation and guidance point bearing errors between 20 and 75 seconds. After 75 seconds, a quasi steady-state behavior is exhibited as the vehicle trajectory oscillates around the forbidden zone boundary. Both of the separation and guidance point bearing mean errors are decaying exponentially because of the forbidden zone boundary separation angle decreasing as vehicle range increases. The vehicle track also moves closer to the contact bearing line (figure 16c) in response to the decreasing boundary separation angle.

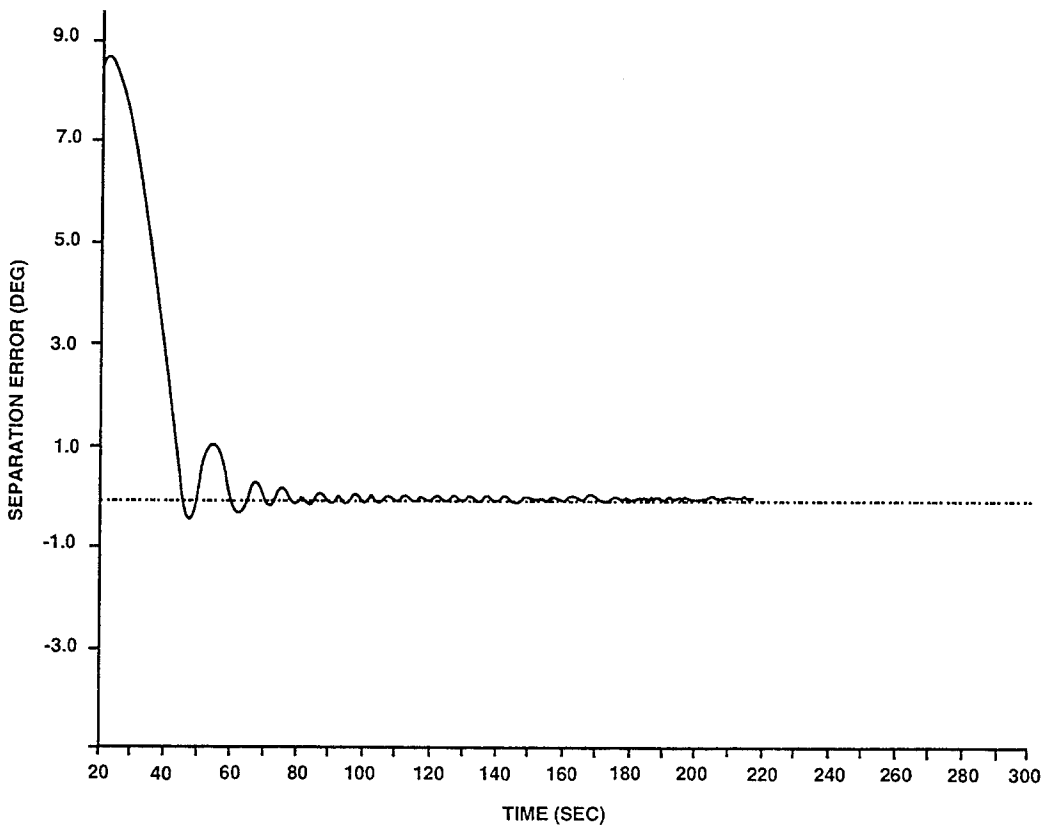

Figure 16a. Boundary Separation Error for Run Number 3

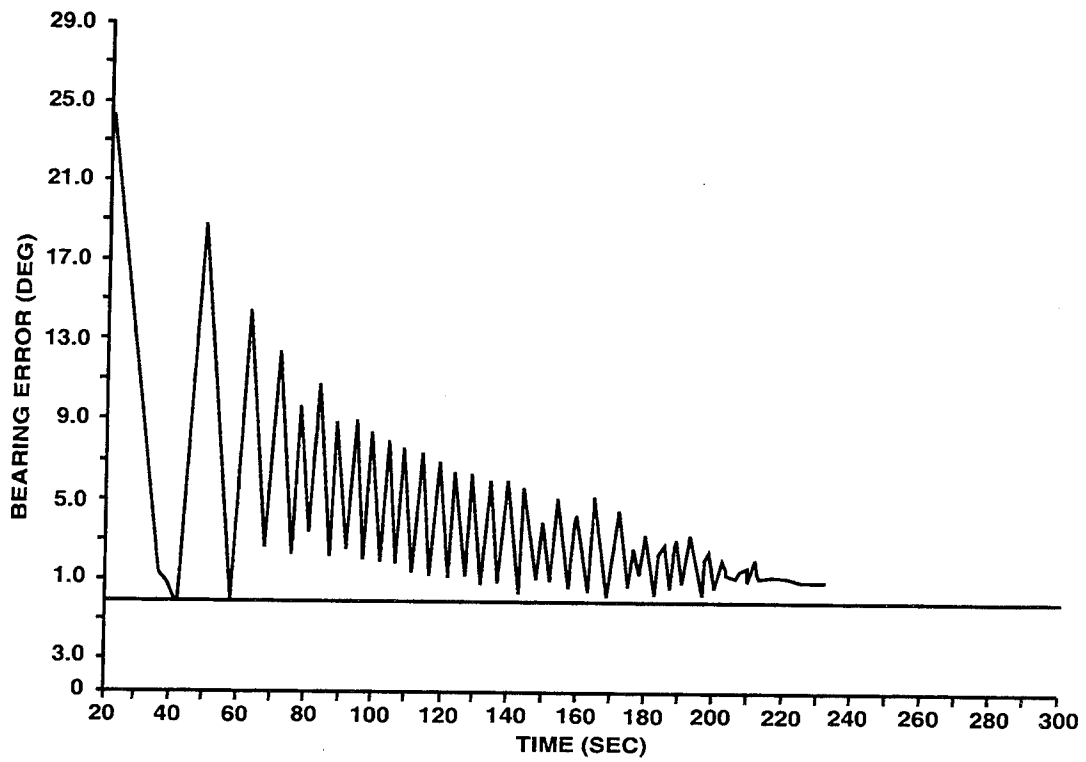

Figure 16b. Guidance Point Bearing Error for Run Number 3

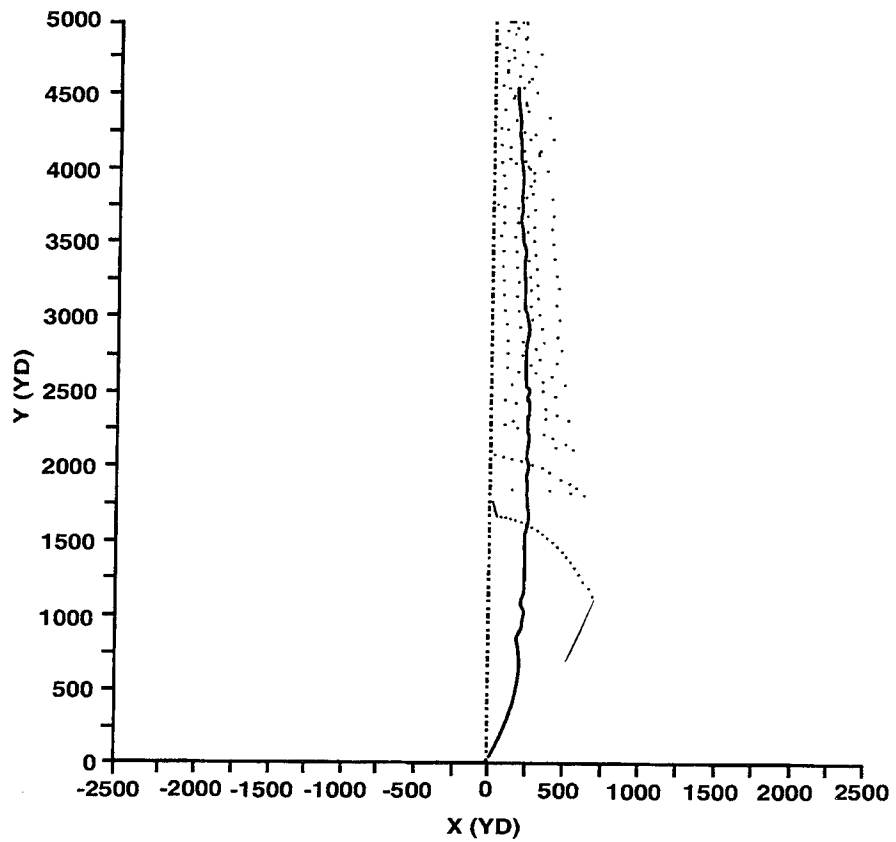

Figure 16c. Hierarchical Beam Rider Trajectory for Run Number 3

3.3 LINEAR MOTION

Run number 4 is for the situation in which the launcher and the contact are both traveling on the same fixed course of 90° and the same constant velocity throughout the run. The vehicle is launched on a course of 25° . When control is initiated, the vehicle is within the forbidden region as shown by the large negative separation error in figure 17a. The hierarchical controller selects primary control and negative course commands are issued to steer the vehicle to exit this zone. At initiation of control, the vehicle orientation is such that the guidance point bearing error is decreasing as the vehicle is steered away from the bearing line (initially the vehicle and vehicle guidance point are on opposite sides of the contact bearing line). As the vehicle separation angle is increased, the guidance point error goes to zero and then becomes more negative until the vehicle crosses the forbidden zone boundary at 31 seconds. At this point, the secondary controller is activated and the guidance point bearing error is reduced to approximately zero (figure 17b) returning the guidance point to within proximity of the contact bearing line at 50 seconds. The motion of the contact bearing line, the size of the guidance distance, the orientation of the vehicle, and the decreasing boundary separation angle with increasing vehicle range result in a geometry that allows the vehicle to maintain the guidance point close to the contact bearing line without re-penetrating the forbidden zone for the remainder of the run (figure 17c). Geometries in which the vehicle is pursuing the contact bearing line produce the best boundary separation and guidance point bearing error responses and minimize the switching between primary and secondary control.

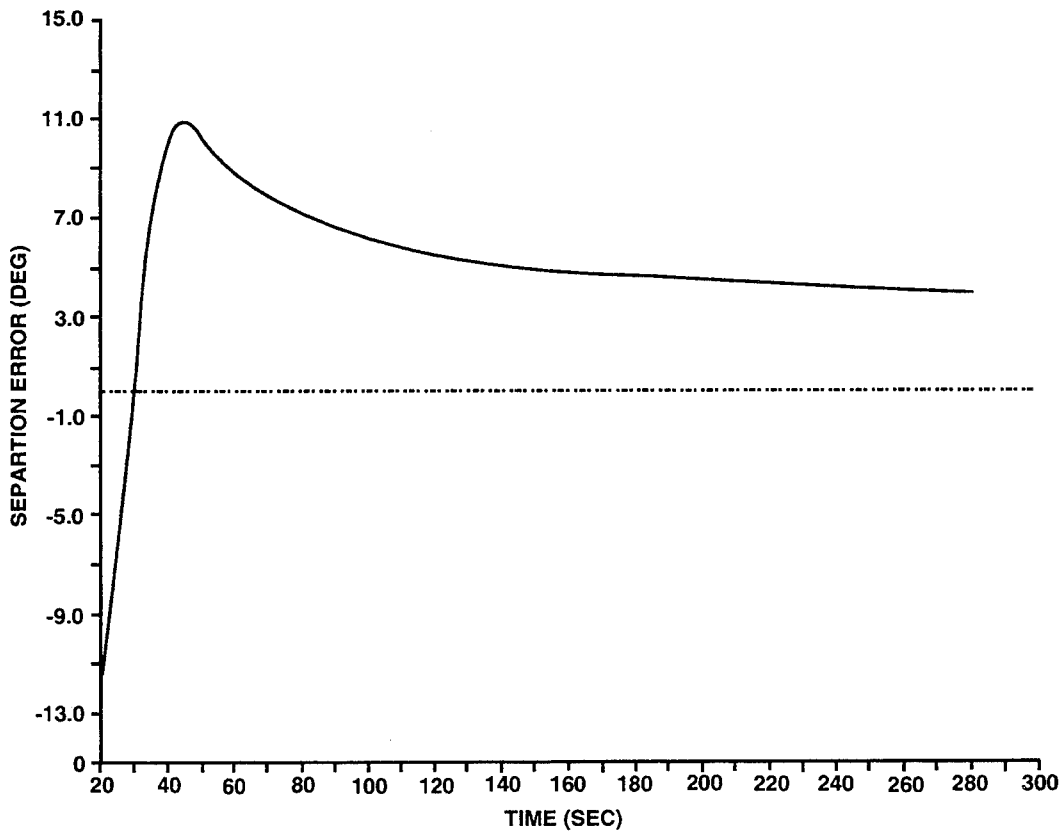

Figure 17a. Boundary Separation Error for Run Number 4

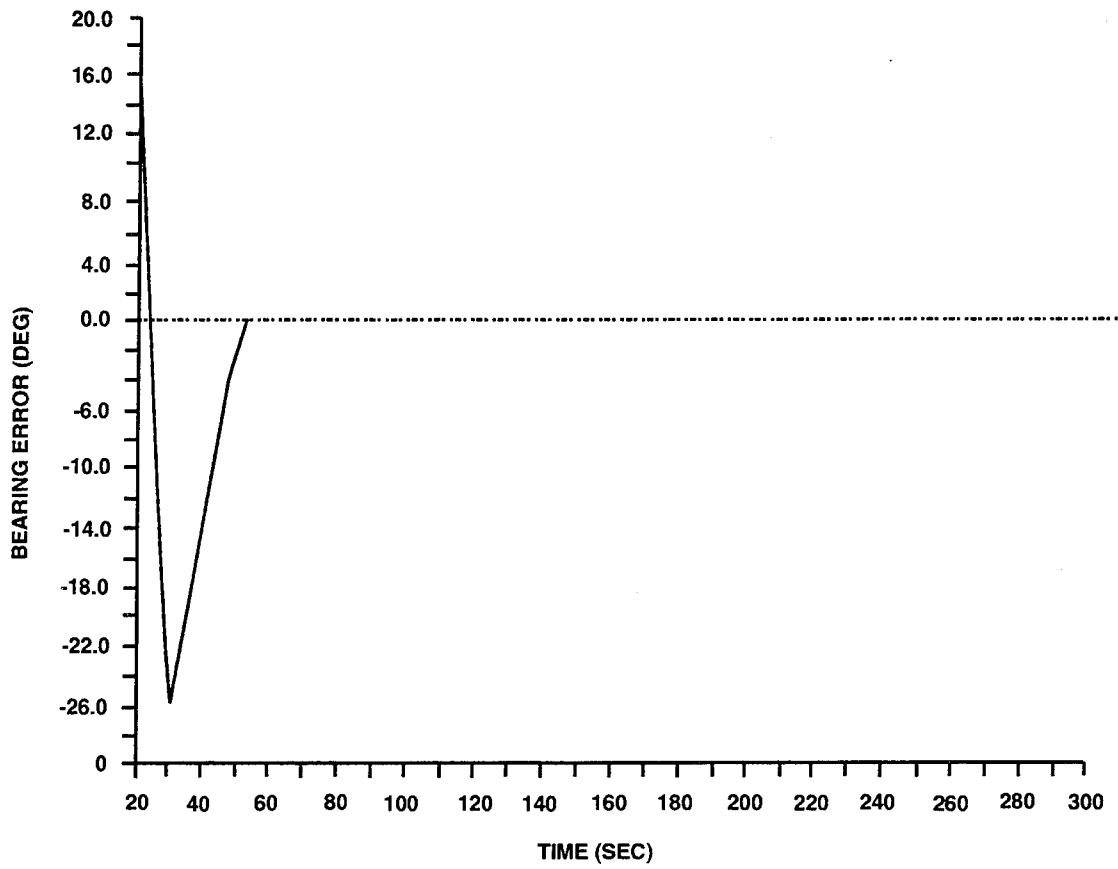

Figure 17b. Guidance Point Bearing Error for Run Number 4

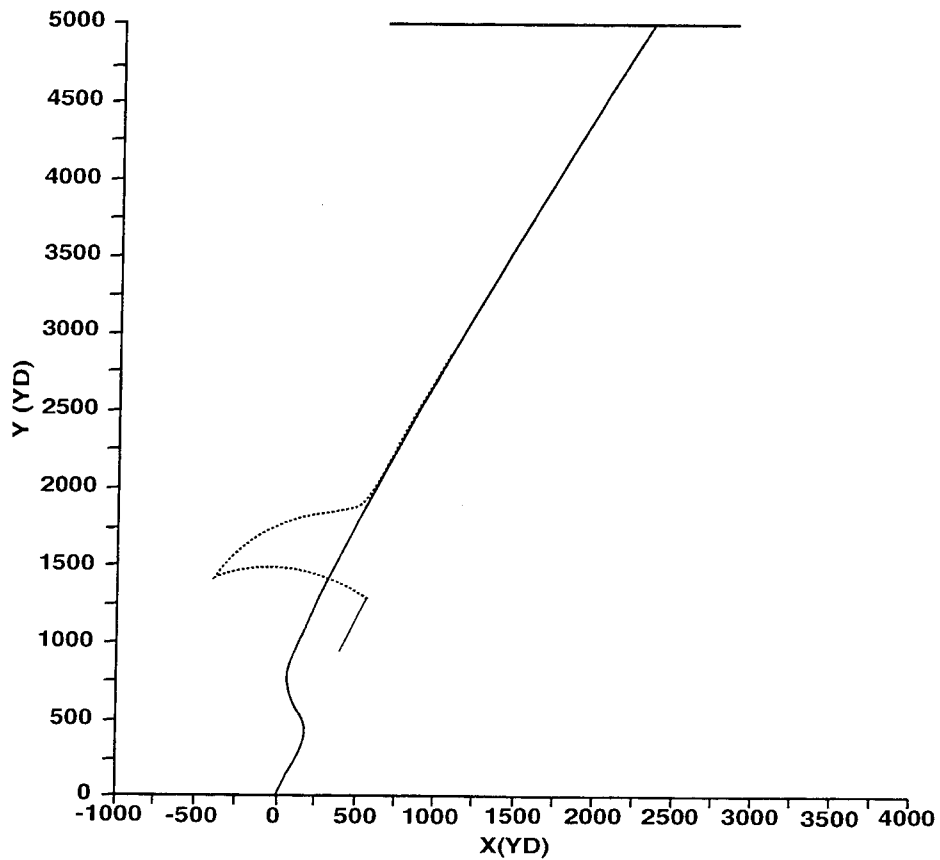

Figure 17c. Hierarchical Beam Rider Trajectory for Run Number 4

4. CONCLUSIONS

A fuzzy control system for beam rider guidance of a vehicle launched from a moving platform against an evasive contact was formulated. A hierarchical structure was used to allow the system to mediate between two competing goals. Robust performance was demonstrated via the use of a computer simulation.

The beam rider control required the determination of vehicle commands that placed/maintained a point, a fixed distance ahead of the vehicle, on or near a time-varying contact bearing line. In addition, the control had to be executed in a manner that maintained the vehicle outside a predefined zone (forbidden region).

The fuzzy controller achieved good system performance using four sets of rules. Different sets of rules were required to achieve primary and secondary goals while necessarily accounting for which side of the line the vehicle was on. The sets of rules used indications of the size of angular errors associated with the contact, the forbidden zone, the vehicle, and the vehicle laminar point in conjunction with estimates of the vehicle's closure/opening rates on both the forbidden zone and contact bearing line. Further, the change in the position of the guidance point, because of a given course command, is a function of tactical parameters. Compensation was made by introducing a gain that conditioned the outputs from the fuzzy controller. The rules were formulated using only intuitive knowledge and experience regarding characteristic beam rider operation. Formulation of the controller did not require any further mathematical description of system dynamics. The commands generated by the controller produced smooth vehicle trajectories, during both transient and steady state, for all runs examined. The guidance point was placed in the proximity of the bearing line, under the constraint that required the vehicle to remain outside a predefined zone, with minimum overshoot and for various types of contact motion. Good behavior was demonstrated for stationary, linear, and nonlinear contact motion (sample stationary and linear runs are included).

The hierarchical fuzzy beam rider guidance scheme devised has the following advantages and new features:

- The fuzzy controller design emulates operations that reflect heuristic considerations through the use of a rule-base expert system in which is embedded a knowledge base that reflects the thinking processes a person might go through while manipulating the system.
- The controller design is such that it mediates between two competing goals through the use of a hierarchical structure.
- The fuzzy controller design *automatically* generates and issues vehicle control commands such that the vehicle follows a beam rider trajectory while remaining outside a pre-specified zone.
- The fuzzy control scheme is a simple design that provides robust behavior. As new situations arise, the controller design has the inherent capability to be tuned using experimental data from the new situations

5. REFERENCES

1. A. F. Bessacini and R. F. Pinkos, "A Constrained Fuzzy Controller for Beam Rider Guidance," NUWC-NPT TR 10,200, Naval Undersea Warfare Center Division, Newport, RI, 28 May 1993.
2. E. Cox, "Fuzzy Fundamentals," *IEEE Spectrum*, October 1992, pp. 58-61.
3. C. C. Lee, "Fuzzy Logic in Control Systems: Fuzzy Logic Controller Part I and Part II," *IEEE Transactions on Systems, Man, and Cybernetics*, vol. 20, no. 2, 1990, pp. 404-435.
4. B. Kosko, *Neural Networks and Fuzzy Systems*, Prentice Hall Inc., Englewood Cliffs, NJ, 1992.

INITIAL DISTRIBUTION LIST

Addressee	No. of Copies
Commander, Submarine Force Atlantic	1
Commander, Submarine Force Pacific	1
Commander, Submarine Development Squadron 12	1
Advanced Research Projects Agency	1
Submarine Base, Pearl Harbor	1
Naval Postgraduate School	1
Naval War College	1
Naval Sea Systems Command (PMS-393, ASTO-E, SEA-06U PMO-425, PMO-4253 -- W. Burles)	5
Naval Air Warfare Center Weapons Division, Carderock, (Code C2158 -- P. Kerston)	1
Defense Technical Information Center	12
Center for Naval Analyses	1