

NAVAL POSTGRADUATE SCHOOL Monterey, California



THESIS

**ANIMATION WITHIN A MULTIMEDIA TRAINING
SYSTEM FOR NIGHT VISION GOGGLES**

by

Sean T. Epperson

March, 1995

Co-Advisors:

Kishore Sengupta
Alice Crawford

Approved for public release; distribution is unlimited.

19950510 034

DTIC QUALITY INSPECTED 6

REPORT DOCUMENTATION PAGE			Form Approved OMB No. 0704-0188	
Public reporting burden for this collection of information is estimated to average 1 hour per response, including the time for reviewing instruction, searching existing data sources, gathering and maintaining the data needed, and completing and reviewing the collection of information. Send comments regarding this burden estimate or any other aspect of this collection of information, including suggestions for reducing this burden, to Washington headquarters Services, Directorate for Information Operations and Reports, 1215 Jefferson Davis Highway, Suite 1204, Arlington, VA 22202-4302, and to the Office of Management and Budget, Paperwork Reduction Project (0704-0188) Washington DC 20503.				
1. AGENCY USE ONLY (Leave blank)		2. REPORT DATE	3. REPORT TYPE AND DATES COVERED	
		March 1995	Master's Thesis	
4. TITLE AND SUBTITLE			5. FUNDING NUMBERS	
ANIMATION WITHIN A MULTIMEDIA TRAINING SYSTEM FOR NIGHT VISION GOGGLES				
6. AUTHOR(S)				
Epperson, Sean T.				
7. PERFORMING ORGANIZATION NAME(S) AND ADDRESS(ES)			8. PERFORMING ORGANIZATION REPORT NUMBER	
Naval Postgraduate School Monterey CA 93943-5000				
9. SPONSORING/MONITORING AGENCY NAME(S) AND ADDRESS(ES)			10. SPONSORING/MONITORING AGENCY REPORT NUMBER	
11. SUPPLEMENTARY NOTES				
The views expressed in this thesis are those of the authors and do not reflect the official policy or position of the Department of Defense or the U.S. Government.				
12a. DISTRIBUTION/AVAILABILITY STATEMENT			12b. DISTRIBUTION CODE	
Approved for public release; distribution unlimited				
13. ABSTRACT (<i>maximum 200 words</i>) Night vision goggles (NVG) provide aircrews the ability to perform many daylight operations in the nighttime environment. However, with these enhanced nighttime capabilities many mishaps occur due to aircrews overestimating the capabilities of the goggles. To reduce the risks when using NVGs, increase combat survivability, and increase combat effectiveness, continuous training is needed. A promising training alternative is multimedia. This thesis focuses on the implementation of animation within a computer-based interactive multimedia system to assist in training aircrews who use NVGs. The extent any media such as animation can be implemented to provide effective training through multimedia is largely dependent on adherence to fundamental instructional design principles. This research details the methods and techniques used in the development of animation that is part of the NVG multimedia prototype. Also a description is given of the hardware components and software applications utilized, as well as how the prototype was developed. The findings show that animation is very useful for certain instructional roles and conditions. Animation's most significant uses are in presenting procedural tasks, providing a visual representation of information that cannot be captured by other media, and the principles of operation of NVGs.				
14. SUBJECT TERMS			15. NUMBER OF PAGES	
Multimedia, Animation, Computer Aided Instruction, Night Vision Goggles			56	
			16. PRICE CODE	
17. SECURITY CLASSIFICATION OF REPORT	18. SECURITY CLASSIFICATION OF THIS PAGE	19. SECURITY CLASSIFICATION OF ABSTRACT	20. LIMITATION OF ABSTRACT	
Unclassified	Unclassified	Unclassified	UL	

Approved for public release; distribution is unlimited.

**ANIMATION WITHIN A MULTIMEDIA TRAINING SYSTEM FOR NIGHT
VISION GOGGLES**

by

Sean T. Epperson

Lieutenant, United States Navy

B.S., United States Naval Academy, 1988

Submitted in partial fulfillment

of the requirements for the degree of

MASTER OF SCIENCE IN INFORMATION TECHNOLOGY MANAGEMENT

from the

NAVAL POSTGRADUATE SCHOOL

March 1995

Author:

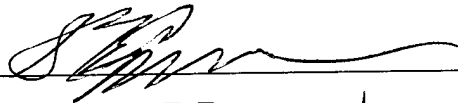

Sean T. Epperson

Approved by:

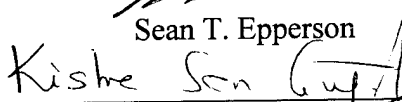

Kishore Sengupta, Co-Advisor

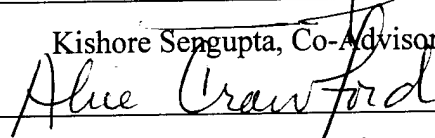

Alice Crawford, Co-Advisor

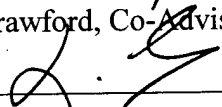
David Whipple, ~~Chairman~~

Department of Systems Management

ABSTRACT

Night vision goggles (NVG) provide aircrews the ability to perform many daylight operations in the nighttime environment. However, with these enhanced nighttime capabilities many mishaps occur due to aircrews overestimating the capabilities of the goggles. To reduce the risks when using NVGs, increase combat survivability, and increase combat effectiveness, continuous training is needed. A promising training alternative is multimedia. This thesis focuses on the implementation of animation within a computer-based interactive multimedia system to assist in training aircrews who use NVGs. The extent any media such as animation can be implemented to provide effective training through multimedia is largely dependent on adherence to fundamental instructional design principles. This research details the methods and techniques used in the development of animation that is part of the NVG multimedia prototype. Also a description is given of the hardware components and software applications utilized, as well as how the prototype was developed. The findings show that animation is very useful for certain instructional roles and conditions. Animation's most significant uses are in presenting procedural tasks, providing a visual representation of information that cannot be captured by other media, and the principles of operation of NVGs.

Accession For	
NTIS CRA&I	<input checked="" type="checkbox"/>
DTIC TAB	<input type="checkbox"/>
Unannounced	<input type="checkbox"/>
Justification	
By	
Dist. istribution /	
Availability Codes	
Dist	Avail and/or Special
A-1	

TABLE OF CONTENTS

I. INTRODUCTION	1
A. BACKGROUND	2
1. Computer-Based Instruction	2
2. Multimedia	4
3. Animation	5
B. NIGHT VISION GOGGLES	6
C. SCOPE OF THE THESIS	8
D. THESIS ORGANIZATION	9
II. INSTRUCTIONAL CONDITIONS FOR ANIMATED VISUALS	11
A. LEARNING	12
1. Behaviouristic Paradigm	12
2. Cognitive Paradigm	13
B. LEARNING FROM ANIMATION	14
1. Perception	15
2. Memory	16
a. Dual-Coding Theory	16
C. EXPERIMENTAL RESEARCH OF ANIMATION AND LEARNING	17
1. Experiments	18
2. Guidelines for the Use of Animation	20
a. Instructional Roles	20
b. Instructional Conditions	21
III. ANIMATION IN THE NIGHT VISION GOGGLE MULTIMEDIA TRAINING TOOL	23
A. DOMAIN KNOWLEDGE	24
B. COMPUTER CONFIGURATION	25
1. Computer Hardware	25
2. Software	26
a. Authoring Tool	26
b. Animation Software	27
3. Limitations	28

C. DEVELOPMENT PROCESS	29
1. Selection of Lessons for Multimedia Enhancement	29
2. Establish Learning Objectives	30
3. Selection of Media	30
a. Why Animation?	30
4. Flow Charting	31
5. Storyboarding	32
6. Lesson Production	33
a. Creation of an Animation	33
b. The Use of Animation with Other Media	36
IV. RECOMMENDATIONS AND CONCLUSIONS	39
A. RECOMMENDATIONS	39
B. CONCLUSIONS	40
LIST OF REFERENCES	43
INITIAL DISTRIBUTION LIST	47

I. INTRODUCTION

The versatility of today's computers and software has expanded opportunities for development of Computer-based instruction (CBI). Currently, multimedia is a promising technology that can fit instructional needs. As multimedia technology rapidly matures, its capabilities must be properly applied when used in the realm of instruction. The novelty of multimedia provides temptations to apply this new technology to instructional material that may be better taught by more traditional means. Further, any method of instructional delivery cannot maximize its potential unless fundamental instructional design principles are considered. The development of multimedia courseware is more complex and time consuming than traditional instruction development. However, the fundamentals of instructional design are still applicable. The result of developing multimedia instruction without focusing on the objective of creating effective instruction, is a flashy system that does not provide quality instruction. Animation, a component of multimedia, has been used in various ways to create a learning experience. However, often animation has been used without the proper consideration for fundamental instructional design principles. This thesis examines the extent to which animation can be used within multimedia instructional tools. More specifically, by using multimedia design methods this thesis studies the feasibility of using animation in a multimedia system to enhance pilot's visual skills using Night vision goggles (NVG). The multimedia tool developed as part of this thesis and in previous research (Bryant & Day, 1994), the Night Vision Goggle multimedia training application, is used as a basis for discussion.

This chapter introduces computer-based instruction, multimedia, and animation. These topics are introduced by defining each term, discussing the current status of each technology, and discussing their applicability to NVG training. The next portion of the chapter contains a discussion of NVGs and the rationale for investigating the feasibility

of applying multimedia and animation technology to NVGs. The last sections present the scope and the organization of the thesis.

A. BACKGROUND

1. Computer-Based Instruction

The uses of instructional computing have been categorized as either a learning tool, tutor, or tutee (Alessi & Trollip, 1991). As a tool, the student utilizes the computer merely as a learning implement. The student's interest in the computer is only to provide an output that is another piece of knowledge to use in the process of their study. As an example, a spreadsheet can be used as a tool in the process of learning principles of finance. Used as a tutor, the computer is actually the medium through which the instruction is delivered. The computer contains the subject matter knowledge for study. Further, the computer delivers instruction based on the design of the instructional tool. As a tutee, the student teaches the computer and thereby learns from it. (Alessi & Trollip, 1991) This thesis emphasizes utilizing CBI as a tutor.

Development of computer-based instruction began thirty years ago. During this period computer technology progressed rapidly. Over this time span, the development process has matured from the use of a low level language for coding to today's use of authoring tools, which require little or no scripting. However, as the technology has dramatically improved with microcomputers, the improvement in the quality of CBI has been much slower. Factors such as hardware and software incompatibility, shortages of qualified developers of computer-based courseware, and confusion over the role that computers should play in instruction are cited as reasons for this disparity. (Alessi & Trollip, 1991)

Because CBI is a specialized form of instruction, selecting the correct medium to present and precisely communicate the teaching material is essential. When media are improperly selected, misconceptions and unintentional learning can occur (Rieber, 1991a). Essentially, computers should be utilized when the benefits of doing so outweigh those of other methods. Some instances when CBI is beneficial are: the high costs of

alternative training methods, concern for safety during instruction, student practice by repetition is required, motivation for students is needed, or any other issue that prevents effective instruction by traditional means (Alessi & Trollip, 1991).

When designing any presentation, the process of instruction must be considered. The components of effective instruction follow these four phases: presenting information, guiding the student, allowing for student practice, and assessing student learning (Alessi & Trollip, 1991). When developing a computer instruction tool these components must be considered just as an instructor would in preparing for a traditional class.

Numerous studies have compared the effectiveness of teaching methods that utilize CBI to those using books, lecture, and/or video-tape. In a review of these studies by Kulik & Kulik (1986), as presented in Alessi & Trollip (1991), only a small improvement in instructional effectiveness is credited to CBI. Also, studies have compared the effectiveness of different media utilized in CBI such as interactive video, animation, still graphics, sound, and text. Fletcher (1990) reported that CBI utilizing interactive video is more effective than traditional instruction. He added, that though this distinction has been made by many others, little theoretical justification or instructional design basis is given to explain the increased effectiveness. Overall, conclusions have been inconsistent in determining which design characteristics of CBI provide added benefit over more traditional approaches (Alessi & Trollip, 1991). Many studies explain the inconsistent results as an indication of poor methods used to apply different media to learning (Park & Hopkins, 1993). This has prompted the call for further research into the different roles that CBI is to play in instruction. For example, what are the roles of the various components of multimedia when used for instruction?

As research into the effectiveness of CBI continues, new technological advances in microcomputers have resulted in the emergence of multimedia into CBI. The use of this technology is also still under study. Organizations continuously search for more effective alternative training methods. Many factors provide a driving force for the search of alternatives. Training effectiveness, reducing training cost, added realism, improving

safety, and more interesting training are considerations when looking for new methods of instruction (Falk & Carlson, 1992; Alessi & Trollip, 1991). In 1992, a Naval Air Systems Command study concluded that advanced technologies should be studied as part of an effort to enhance the instruction of NVG performance limitations and visualization (Ciavarelli, Sengupta, & Baer, 1994). This thesis is part of an effort to examine how CBI and multimedia can supplement NVG training.

2. Multimedia

Multimedia is the presentation of material using multiple forms of media. Today, the term multimedia has become associated with computers that are capable of communicating information through many different inputs and outputs (Blattner & Dannenberg, 1992). For example, multimedia has given the computer human-like qualities such as the abilities to hear and speak. These advances have made the computer more personal and less intimidating for the user. Within a multimedia presentation the available tools are full motion video, animation, sound, images, graphics, and text.

Multimedia has given designers of CBI more flexibility by providing many different options for presentation. However, with the increased flexibility comes the temptation to depart from the principles of effective instruction. For example, the bells and whistles that can be added to applications may seem appealing at first, but may actually hinder learning due to the distractions. These distractions draw the learner's attention from the instructional material to insignificant portions of the user interface. Understanding the capabilities and limitations of multimedia will help in the design of more effective applications (Howles & Pettengill, 1993).

Multimedia applications provide an opportunity to create instructional tools which can provide benefits that conventional teaching methods cannot deliver. Many of the advantages cited which multimedia offers are satisfaction with instruction, creation of an interactive environment, and powerful visual enhancements to complement traditional instruction (Falk & Carlson, 1992). With this in mind, the concept of designing and implementing a night vision tutorial is a promising way of improving flight operations

with NVGs. Utilizing an interactive multimedia instruction tool, there is potential for aviation personnel to gain proficiency when other training aids are not available or do not satisfy training objectives. Since many capabilities of the NVGs cannot be conveyed in a classroom environment, tools such as video, animation, and sound can provide valuable exposure to the limitations of the night visual environment.

3. Animation

Computer animation is defined as a series of rapidly changing computer screen displays that present the illusion of movement. Animation is not real motion rather only a representation. Computer animation "operates on a draw, erase, change position, draw repetition to produce the illusion of motion" (Rieber & Kini, 1991). The perception of motion is developed when a series of still images are presented to the human visual system and mentally the illusion of continuous motion is created. This illusion is perceived as continuous when images are shown at a rate of at least fifteen frames per second, otherwise motion appears choppy. To provide the appearance of continuous motion there must be some correspondence between successive displays. If changes between successive displays are too drastic, then the animation becomes less convincing. In this way the human visual system takes two separate objects and creates a relationship between the two, thus the perception of a single moving object is created (Rieber, 1991a).

Animation is a very popular medium in computer-based instruction. But why is animation used in applications? What is the intent of using animation? Often it appears purely to impress rather than to actually communicate information that is to be learned from instruction. Animation has been utilized with any combination of three intents: attention-gaining, presentation, and practice. (Rieber, 1990a)

The perceptual, theoretical and empirical foundations to explain and support the use of animation in instruction have not yet been firmly established by CBI research (Wetzel, Radtke & Stern, 1994). Much of the animation that is incorporated into instructional tools is done based on intuition and the assumption that the animation must improve learning (Baek & Layne, 1988). The success of animation lies in the overall design of the

instruction. Selective uses of animation prove to result in greater instructional effectiveness (Mayer & Anderson, 1991). For example, animation may be most appropriately applied to material which requires conveying an understanding of motion or changes over time.

Within multimedia, animation is a graphic tool that offers the ability to depict concepts that cannot be captured by other means. Animation gives the designer the ability to emphasize the objectives of each lesson. Many NVG capabilities cannot be captured by photographs and video. Animation should enhance the training of these concepts. For example, the process of photons traveling through a NVG intensifier tube cannot be photographed, but this process of photo-multiplication can be represented through animation. Animation provides this ability to customize the material in a training application. Further, using animation provides the trainee an opportunity for interactive learning, which should lead to improved learning effectiveness (Rieber, 1990a).

B. NIGHT VISION GOGGLES

Nighttime aviation has placed more emphasis on night imaging devices that operate in the optical radiation portion of the electromagnetic spectrum. The night vision goggles (Figure 1) are devices that amplify existing available light such as moonlight and starlight, to enhance nighttime vision. The result is that pilots gain the capability to perform many daylight operations in the nighttime environment. However, to maximize the benefits of NVGs, aviation personnel require extensive training to acquire an understanding of the use, capabilities and limitations of the goggles. (MAWTS-1, 1993)

It is necessary to appreciate the needs of aviators during nighttime operations to understand the training aid requirements for NVGs. Combat operation survivability is directly dependent on minimizing the threat's capabilities while maximizing your own. Modern air warfare has taken this idea into the arena of nighttime flying. The limitations of nighttime flying can be diminished by enhancing our capabilities through the use of nighttime low level operations. With the aid of NVGs, our ability to conduct operations at night reduces the probability of detection. Therefore, nighttime operations increase the

tactical advantage of surprise and decrease the chance of detection, resulting in increased combat effectiveness. (MAWTS-1, 1993)

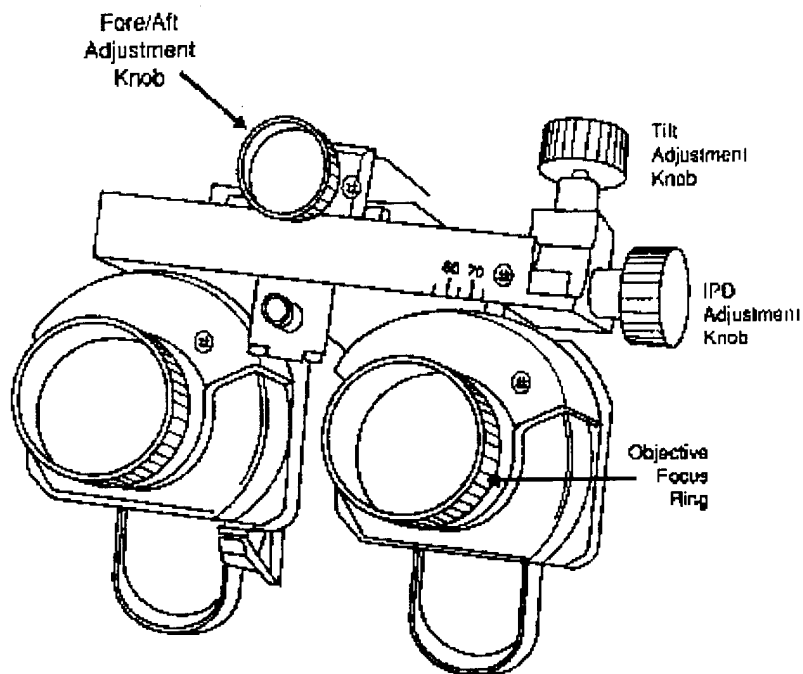

Figure 1. Cat Eyes version of night vision goggles. (MAWTS-1, 1993)

The problem that must be addressed is that the mishaps that occur during NVG flights are often the result of aircrews overestimating the capabilities of the goggles (Ciavarelli, Sengupta, & Baer, 1994). Given the capabilities that NVGs do offer, effective modes of training must be utilized to ensure that goggles are used safely in order to fully maximize those capabilities. Constant aircrew training of all aspects of NVG operation, capabilities and limitations are required to maintain proficiency. The visual misconceptions and illusions that can occur while wearing the goggles, such as difficulty with depth perception and distance estimation, must be presented to aircrews in a training environment prior to operational experiences.

Current NVG training is organized around classroom instruction, on-the-job training, on-site Night Imaging and Threat Evaluation Laboratories (NITE Lab) and NVG compatible full-mission simulators (Ciavarelli, Sengupta, & Baer, 1994). However, not all aviation communities have the benefit of all of these programs. The associated safety concerns that are a part of any NVG operations demand that extensive training be conducted. Classroom training cannot convey the high degree of realism that is needed to appreciate the capabilities and the limitations of NVGs in order to improve safety. In the current environment of shrinking training funding, alternative methods of NVG training are needed. The Multimedia Laboratory at the Naval Postgraduate School is exploring the option of multimedia-based instruction.

The emergence of multimedia CBI provides a promising NVG training alternative. Previous research (Bryant & Day, 1994) began the development of a prototype and examined various methods in which multimedia technology could be applied to NVG training. Hardware and software were selected and implemented as a proof of concept. Therefore, due to the preliminary nature of the work much more domain specific content must be incorporated into the prototype. Bryant and Day faced many more hardware and software configuration and integration issues than are intended in this thesis. This follow-on study will concentrate on developmental issues, specifically the use of animation for the creation of a NVG multimedia instructional tutor.

C. SCOPE OF THE THESIS

The scope of the thesis entails developing a working Windows-based multimedia prototype tutoring system, and utilizing an authoring tool (Macromedia's Authorware Professional) to build the application. From the knowledge gained in the development of the Night Vision Goggle multimedia training application, this thesis examines the feasibility of using animation within a multimedia system to enhance an aircrew's NVG skills. The development of the system is based on the Marine Corps Helicopter NVG manual and lesson plans.

D. THESIS ORGANIZATION

The next chapter introduces the theory and concepts related to learning and multimedia. Also, Chapter II reviews the research related to animation and its uses in computer-based instruction. Within this review, the question of the extent to which animation can be used in computer-based instruction is examined. Chapter III discusses design, methodology, and implementation issues faced in the course of developing a multimedia training tool, specifically the Night Vision Goggle multimedia training prototype. The final chapter addresses conclusions for uses of animation within multimedia training applications.

II. INSTRUCTIONAL CONDITIONS FOR ANIMATED VISUALS

The use of animation is common in CBI, but the theoretical basis for its use has not been firmly established (Rieber, 1990a). As the ability of the microcomputer to produce more complex and realistic graphics grows, the temptation to incorporate animation into instructional tools is increasing (Mayer & Anderson, 1991). Animation in instructional courseware is frequently utilized to add flair rather than to enhance learning. Without a proper perspective of learning and fundamental methods of instruction, ineffective multimedia instructional material is produced.

To derive fundamental guidelines that determine to what extent animation can be used within multimedia instructional tools, an examination of studies is required in the fields of computer-based instruction and animation. The purpose of this review is twofold. First, to determine which psychological components of learning influence the learning from animated visual displays. Secondly, to define characteristics of instructional material that can be effectively presented using animation.

Before beginning a review of studies, one needs an understanding of how people learn and remember information in CBI. The justification for using various media in a CBI application should be based on optimizing learning and supporting learning objectives (Gotz, 1991). There are several learning theories present in CBI literature that suggest methods to enhance learning from computers. However, no single learning theory applied to animation provides sufficient empirical evidence to consistently support the use of animation. Many studies have found animation is more effective than static visuals or text (e.g., Rieber, 1990a; Rieber, 1991b; Baek & Layne, 1988). However, the results have not been conclusive and the development of design methods is ongoing, especially within the realm of multimedia.

This chapter begins by examining the process of learning from computers. More specifically, the behavioristic and cognitive theories of learning are studied to provide background for understanding the rationale for the use of various media, particularly

animation. The last section of this chapter reviews the research that has been conducted on animation in CBI. The next chapter addresses how the findings of this review can be applied to the domain of NVGs as a means of creating an effective training tool for aircrews.

A. LEARNING

For the designer of animation for CBI, an understanding of the learning process is essential to provide a perspective that results in more effective and convincing uses of animation. To answer the questions of to what extent animation can be used or when, where, why and how to utilize animation, an appreciation of how people learn from visual media is required. Park and Hopkins (1993) in determining conditions for the use of "dynamic visual displays" analyzed two psychological paradigms, behavioristic and cognitive. These two paradigms have been the basis for research in determining the roles of visual displays (Park & Hopkins, 1993). Given that animation is a subset of dynamic visual displays it is appropriate to apply these paradigms.

1. Behavioristic Paradigm

The behavioristic paradigm is the basis of early studies into the theoretical foundations of CBI. This paradigm emphasizes "the principles of associative and perceptual learning, and construction of learning conditions using visual displays, eliciting necessary responses required in the task" (Park & Hopkins, 1993). Though behavioristic theory is applicable to all forms of stimulus, not just visuals, the concept of conditioning responses based on instruction material is the primary emphasis (Gotz, 1991). For example, by controlling the visual display, which is the stimulus, the desired association between the stimulus and the response is created. The association between responses and stimulus is the knowledge that is to be retrieved when that stimulus is presented again.

The behavioristic approach is based on the "management of stimulus-response contingencies" (Park & Hopkins, 1993). By developing courseware under this precept, visual displays become the means of establishing conditions to control responses. The

developer's task is to manage these displays so the correct conditions are created to ensure the learner gains new response capabilities that he or she did not have prior to instruction. Therefore, the process of creating visual-based instruction becomes one of choreographing the proper scenes or stimuli, which create the desired new response capabilities. (Park & Hopkins, 1993)

CBI that is created on the basis of a behavioristic paradigm is called programmed instruction. Using programmed instruction the learner is directed through the material based on learning objectives. Learning material is systematically presented focusing on reinforcing responses (Goldstein, 1993). The learner is given little or no opportunity to influence the learning process by determining the interaction with the computer. The interaction that is utilized in programmed instruction occurs from learner responses and the feedback based on these responses. Also, the instructional tool is preprogrammed to proceed on a predetermined path. The learner does not have the ability to determine which portions of the instruction to follow next. These limitations are often cited as the weaknesses of programmed instruction. Further, the emphasis of stimulus-response gives little consideration to the learners ability to cognitively process visual material. Today's technological advances have given learners the capability to interact with the instructional tool and provide the learner a greater degree of control in shaping the learning process. (Gotz, 1991)

2. Cognitive Paradigm

Visual cognition is defined as "the process of how people perceive and remember visual information" (Rieber, 1991c). The cognitive paradigm assumes that the thought process includes images and visualization. For example, even when reading text, mental images are created to process the material. When information is presented, a new response is not created as behavioristic psychology would suggest but rather the information is processed (Gotz, 1991). The components of this process are "perceiving, remembering, appraising, imaging, reasoning, and thinking" (Filbert, & Weatherspoon,

1993). Cognitive theory views "man as a thinking being" which results in this more systematic characterization (Gotz, 1991).

This paradigm is particularly applicable to dynamic visual displays, such as animation, since it involves visualization and the creation of perceptions. For example, using animation and creating the perception of motion that is not really occurring is essential in creating a convincing animated presentation. Park and Hopkins (1993) found from studying Rieber and Kini (1991) that "representing concepts and tasks involving motion with animation triggers the student's automatic ability of the visual system to induce apparent motion and directly encode them into the imaginal subsystem of memory, while static representation requires the student's ability and effort to form mental images of the task's dynamic nature by connecting and integrating discretely presented information."

Though the behavioristic paradigm is applicable in the development of a multimedia application, the Night Vision Goggle Multimedia training application was developed based on the cognitive paradigm. The reason for selecting this paradigm is to concentrate on the visual thought processes that a learner engages in during instruction when presented visual media like animation.

B. LEARNING FROM ANIMATION

Research has shown the effectiveness of animated visuals is largely dependent on the "task requirements, cognitive load, and selective attention" (Rieber & Kini, 1991). Recognizing these limitations, an understanding of the human visual process is needed. Park and Hopkins (1993) categorized the functional processes of visuals in the following manner:

- (1) Visuals are attention gaining tools.
- (2) Once the attention of the learner is obtained, the display provides a visual cue to significant instructional aspects of the display.

(3) The learner creates perceptions based on visual information that the learners attention has been directed towards.

(4) The learner's perceptions are encoded into memory for recall.

This functional description of the visual process describes the basis for the presentation strategy that has been applied to the use of animation (Rieber & Kini, 1991; Rieber, 1990a). Given this visual process, many advantages of animation are cited. These advantages correspond to components of the functional processes of visuals. Animated visuals are attention gaining mechanisms, which make more appealing presentations and direct a learner's attention (Rieber, 1990a). Visual representations such as animation enhance a learner's ability to visualize material. This visual representation is a memory aid or visual pneumonic that make the material easier to encode into memory (Rieber, Boyce & Assad, 1990).

To further study animation in interactive multimedia instructional tools, this section applies cognitive learning theory to the use of animation. The first cognitive factor contributing to the effectiveness of animation is the perceptual structures that create the illusion of motion and the interpretation of instructional material. The second factor is the mechanism for short-term and long-term retention, which is vital in determining how to develop instruction that will be encoded into memory (Rieber & Kini, 1991). Further, the characteristics of these factors will determine when it is appropriate to use animation to provide added benefit to instruction. The next section examines the factors of perception and memory.

1. Perception

The effectiveness of animation is dependent on the creation of perceptions that will lead to the proper interpretation of what is presented. The process of perception begins with the human visual system directing attention and viewing details from the stimulus. It is essential that the learner's attention is focused so that visual distractions do not influence visual perceptions. After the information is extracted from the environment an interpretation and a mental structure of the visual's meaning is created. Often a

confounding factor in current perceptions is that they are influenced by past experiences and individual paradigms (Forgus, 1966). Regardless of the presentation method, the perceptions created are critical to intentional learning. However, the unintended perceptions are just as important since they can lead to unexpected misconceptions and hinder the learning process.

2. Memory

The objective of any instruction is to present the material in a fashion that will result in the greatest understanding and retention. The goal of understanding is not as simple as presenting the material clearly so that anyone can interpret the information. Within any presentation scheme two people can interpret the information differently. These interpretations are based on perceptions, both past and present. The second goal of retention is the storage of information for later retrieval. Research has shown that regardless of the method of presentation, highly imageable material is recalled with greater success. For example, a description of the operation of a disk drive with all of its moving parts can be visualized easily. On the other hand, more abstract concepts such as "justice" or "freedom" are less concrete and do not form mental images as easily (Rieber & Kini, 1991). A theory that illustrates these observations is Paivio's Dual-Coding theory.

a. Dual-Coding Theory

Paivio's Dual-Coding theory provides an explanation of psychological mechanisms related to the structure of knowledge and instructional practices. It is also the predominant theory on the development of long-term memory structures. (Rieber & Kini, 1991) By providing a functional structure for the mental processing of verbal and visual information, the dual-coding theory has strong implications for the design of multimedia instructional tools.

The dual-coding theory asserts that verbal and visual stimulus are independently encoded. Imagine the human sensory system consisting of verbal and non-verbal subsystems where verbal and visual stimuli enter. Verbal information encodes

sequentially while visual images encode simultaneously. While the information encodes into memory, representational connections exist between verbal and nonverbal modes. These representational connections exist from concrete concepts or properties, which easily trigger internal images in memory. Another connection, an association, is created within each subsystem. For example, within the visual subsystem the mental images of an atom may be associated with an image of a nuclear power plant. Further, this association of atom and nuclear power plant has a referential connection to the verbal subsystem to such words as atom and neutron. These words electron and neutron have an association in the verbal subsystem. From the referential and associative connections between the verbal and visual subsystems, the indirect and direct connections that are created can influence learning and retrieval performance. (Clark & Paivio, 1991)

Dual-coding theory contends that two mental representations exist, verbal and nonverbal. However, the ability to remember visual information is greater than verbal information. For example, by displaying an animation several images are encoded of the same information. This repetition results in a greater probability of recall (Rieber & Kini, 1991). Additionally, by encoding both modes the probability of recall increases due to the fact that if one mode of storage is lost the other still exists.

The intuitive appeal of visual displays within multimedia instruction is supported by the dual-coding theory. Research has shown that information presented in any form that can be successfully abstracted mentally into a visual image and is more likely to be remembered. Therefore, animation that represents highly imaginable information should result in improved recall. Further, research has found that uses of animation support the dual-coding theory (Rieber, Boyce & Assad, 1990; Mayer & Anderson, 1991).

C. EXPERIMENTAL RESEARCH OF ANIMATION AND LEARNING

This section reviews research conducted relating to the effects of animation on learning. The goal of this section is to determine the instructional conditions and roles for which animation is found to be effective. Rieber (1990a) made a recommendation

based on his review of research that animation should be incorporated only when its attributes are congruent to the learning tasks. This observation provides a general direction for the use of animation and is the basis of this section's discussion and analysis of research findings.

Certain instructional materials have characteristics that are appropriate for an animated representation. However, when developing CBI in a multimedia environment where many media are available, the selection of the correct medium or combination of media is essential to learning effectiveness and satisfying learning objectives (Howles & Pettengill, 1993). Therefore, the feasibility of animation is dependent on the learning task. For example, if the learning task is to convey the feeling of the weight of NVGs mounted on a helmet, a verbal description by sound or text may be more effective than a visual representation.

1. Experiments

Mayton, (1991) testing the effects of animation when used in conjunction with text and static visuals, determined that the use of animation was beneficial when it is applied to the task of teaching dynamic processes. Three groups of undergraduate students were given a tutorial on the function of the human heart. One group received a tutorial of text and static visuals with short answer questions to provide feedback. The second group received the same tutorial as the first with the addition of imagery cueing. Imagery cueing is performed by highlighting an area, circling the area of interest on the display, or using arrows to point out the area where the learner is to direct their attention. The third group was given the same presentation as the second with the addition of animated sequences of a pumping heart. The results suggest that the animated group was able to retain information on the operation of the cardiac system, a dynamic process, better than the other two groups.

Studying the effects of animated presentations and cognitive practice, Rieber (1990b) used CBI to explain Newton's laws of motion to fourth and fifth graders. He found that animated presentations were more effective than static graphics. Also, the

lessons were more effective when students were given the opportunity to interactively practice concepts. The results of his study identified certain conditions under which animation can be effectively used:

- (1) The material requires the learner to visualize motion and trajectory.
- (2) The lesson is challenging but not unreasonably so.
- (3) The student's attention is cued to motion and trajectory details contained in the animation.
- (4) The animation is used in tandem with other supportive instructional activities such as practice.

A similar study conducted by Rieber, Boyce and Assad (1990) on university students found no significant differences between animation and static graphics to facilitate the encoding and retrieval of information. However, the subjects in the animation treatment group took significantly less time to complete the post-test measure than either the static graphic or no graphic groups. The conclusion was that animation aided learners in the retrieval task without increasing actual learning.

Mayer and Anderson (1991) investigated how animation can be used to promote scientific understanding. A group of mechanically naive college students were evaluated on the principles of operation of a bicycle pump. A control group received no training on pump operation. The second group only received animated instruction without narration. Other groups viewed an animation on the operation of the bicycle pump with a verbal description before or during the animation. Afterwards, a problem solving test was administered to evaluate the students' understanding of pump operation. Animated training without narration had no more impact on student understanding of the principles of operation than no instruction. Groups receiving animation with narration outperformed both the no-training and animation-only groups. However, the results did not show that the simultaneous presentation of verbal and visual explanations was superior to instruction without a connection between the verbal and visual presentation. This suggests that the coordination of verbal and visual representations assists the learner

in creating connections between the word and the pictures. These results support Paivio's dual-coding theory.

2. Guidelines for the Use of Animation

Research into the contributions of animation to learning has often proceeded without regard to the learning task. This lack of strategic application of animation in research may have prevented the true effects of animation to be discovered (Park & Hopkins, 1993). However, research on animation such as those studies discussed above has created a knowledge base from which future research will continue to work towards conclusive evidence on the utility of animation for learning. In the meantime, developers require guidelines in determining when, where, and why to utilize animation. Park and Hopkins (1993), in their review of the instructional uses of dynamic visual displays, categorized the roles and conditions for which visuals can be effective. A large portion of their reviews entail the use of animation, therefore their conclusions are applicable to animation. These recommendations on the roles and conditions are those which have consistently been applied as justification (Park & Hopkins, 1993).

a. Instructional Roles

To determine the role of animation one considers the characteristics of the instructional material and the learner. However general roles of animation are:

- (1) As an attention guide.
- (2) As an illustration.
- (3) As a representation of domain knowledge.
- (4) As a device model for forming a mental image.
- (5) As a visual analogy or reasoning anchor for understanding abstract and symbolic concepts.

b. Instructional Conditions

The instructional conditions for which animation is appropriate are determined by considering the knowledge domain and how the information can be presented:

- (1) For demonstrating sequential action in a procedural task.
- (2) For simulating causal models of complex system behaviors.
- (3) For visually manifesting invisible system functions and behaviors.
- (4) For illustrating a task difficult to describe verbally.
- (5) For providing a visual motion cue, analogy or guidance.
- (6) For obtaining attention focused on specific tasks or presentation displays.

Chapter III applies these roles and conditions for the use of animation in the domain of NVGs. With a clearer perspective of the visual process and a more empirically sound approach, the issues of applying and designing animation for the training of NVGs are ready for consideration.

III. ANIMATION IN THE NIGHT VISION GOGGLE MULTIMEDIA TRAINING TOOL

The goal of implementing a multimedia training tool in the domain of NVGs is to enhance the quality of aircrew instruction on NVG limitations and visualization of the nighttime environment. The knowledge gained from the earlier analysis of learning and animation is essential to the development and implementation of animation for the training of NVGs. This chapter is a discussion of the issues encountered during the development of the Night Vision Goggle Multimedia training application with a focus on the development of animation. The lessons learned from this development process lead to a preliminary evaluation of the feasibility of using animation in a multimedia system to enhance visual skills using NVGs.

The development of computer-based instruction requires an organized methodology to provide structure and consistency throughout the process. This is also true for multimedia instruction because it is more complex and labor intensive than creating traditional instruction (Howles & Pettengill, 1993). Even though the development of this application is less complex due to the limited scope and number of people participating in the development, these principles are scaleable to other projects.

The first prototype produced by Bryant and Day (1994) provided a vehicle to investigate the basic features that multimedia can perform as a proof of concept in the domain of training NVGs. However, prototyping is an iterative process (Sprague & McNurlin, 1993). Through the use of prototyping, the discovery of new requirements and refinements occurs. The recommendations and the lessons learned from the first prototype provide a knowledge base for following research. For example, the feedback Bryant and Day received from a Naval flight physiologist at the end of their development is incorporated into this second prototype. This second iteration of the prototype is also a collaborative effort of two Masters' students. The other student is Francisco Meza. The

focus of Meza's thesis is on the overall design principles that are applied when creating a multimedia application. During the development of this prototype the development team shared all tasks with the exception of animations and creation of the menu structures. Meza was responsible for the menu structures, while I was responsible for creating animations.

The previous chapter presented the instructional roles and conditions where animation can be effective. In the development of the Night Vision Goggle Multimedia training application these principles are applied to determine whether to use animation, another form of media or traditional forms of training. This chapter discusses the development of the Night Vision Goggle Multimedia training tool prototype. The following sections describe the collection of domain knowledge that is required prior to beginning development of computer-based instruction, the hardware and software configuration used, and the development process. The emphasis of the development process is on the feasibility of animation within the domain of NVGs.

A. DOMAIN KNOWLEDGE

The development of a computer-based training tool requires expert domain knowledge. Often the developer of computer-based instruction may have the cooperation of an expert in the subject matter. However, the designer must become somewhat of a subject matter expert. If the designer of the instruction does not have a full understanding of the material, the resulting application will not challenge the learner or provide effective instruction (Alessi & Trollip, 1991). This principle is typical of preparing any form of instruction. A teacher cannot deliver quality instruction if the teacher does not have a well developed knowledge base of the subject matter.

Neither person in the development team has participated in any form of formal NVG training. In this case, knowledge was obtained from NVG training commands and experts in the field of night imaging devices. The Marine Corps Night Vision Goggles Training Manual (MAWTS-1) and the Night Vision Goggle (NVG) Training Technology Study (Ciavarelli, Sengupta, & Baer, 1994) provides lesson plans and training objectives.

A library of actual night vision video film footage was obtained from various Naval facilities for implementation in the multimedia application. From these resources, the development team acquired the NVG domain knowledge that is incorporated into the application.

B. COMPUTER CONFIGURATION

1. Hardware

The selection and assembly of the computer system used for application development was completed by Bryant and Day (1994). Early in their research the decision was made to create a personal computer (PC) based multimedia instructional application. Table 1 shows the hardware configuration used for the creation of the Night Vision Goggles Multimedia Training tool prototype.

The prototype is developed to run on a 486 (or faster) PC with 8 megabytes (MB) of random access memory (RAM) and a multimedia suite. A PC based instructional tool is a practical choice when considering the ease of hardware setup and the ability to distribute optical versions of the final application to training commands. A 486 PC with 8 MB of RAM is required to smoothly run the animations and transition between displays. The multimedia suite should include, as a minimum, a sound card and speakers. Today these components are common and are readily available to training commands.

	TYPE	MAKE	MODEL
1	PERSONAL COMPUTER	ARM	486-DX2/66
2	MONITOR	PHILLIPS	FAST REFRESH/21"
3	VIDEO CARD	TRUEVISION	BRAVADO-16
4	SOUND CARD	MEDIA VISION	SPECTRUM PRO-AUDIO
5	COLOR SCANNER	HEWLETT-PACKARD	HP SCANJET IIc
6	SPEAKERS	SONY	SRS-D2PC
7	HI-8 COMPUTER VIDEO DECK	SONY	CVD-1000
8	SVHS VCR	PANASONIC	AG-7350

Table 1. Hardware Configuration

2. Software

The selection of software was performed prior to the beginning of the development of this prototype. During the development of the application some software was found to be more useful than others. The advantages and disadvantage are discussed later in the section on animation software. The software actually used in the development of the application is listed in Table 2.

	TYPE	MAKE	VERSION
1	MULTIMEDIA AUTHORING TOOL	MACROMEDIA	AUTHORWARE 2.01
2	VIDEO DIRECTOR	GOLD DISK INC.	FOR WINDOWS 1.0
3	MULTIMEDIA EDITOR	ADOBE	PREMIERE 1.0
4	GRAPHICS EDITOR	ALDUS	PHOTOSTYLER 2.0
5	3-D ANIMATOR	AUTODESK	3D STUDIO 3.0
6	3-D GRAPHICS	MACROMEDIA	MACRO MODEL 1.5

Table 2. Software Configuration

a. Authoring Tool

The development of multimedia applications utilize authoring tools. These authoring tools allow developers to create interactive multimedia applications without coding in the traditional sense (Sprague & McNurlin, 1993). With an authoring tool the emphasis has shifted to *how* to use media rather than the logic that goes into the progression of the application. The two types of authoring tools available are based on timelines and scripts. Timelines allow the developer to sequence media using an icon-based programming language. Scripts use the authoring tool's language to create short modules of code that perform the desired functions.

Macromedia's Authorware is the authoring tool used in the development of this application. Authorware is an object-oriented, visual programming tool that is timeline

based. The benefit of object-oriented authoring tools is that modules can be reused. By storing libraries of commonly used modules, the development of the same functions is more a matter of cut and paste than a reinvention of logic (Macromedia, 1993). The programming involved is limited to creating small routines that perform functions that are not implemented as an icon within Authorware. For example, the control of the Hi-8 computer video deck is performed by the use of scripts containing Multimedia Control Interface (MCI) commands. These commands conform to a standard that Authorware will recognize. However, most functions needed to develop multimedia courseware are built into the authoring tool.

Authoring tools allow more rapid development of applications. For example, developing courseware using a third generation language may require a significantly greater amount of flowcharting to capture the complex procedures that are to be coded (Alessi & Trollip, 1991). However, with an authoring tool like Authorware that utilizes time-line and icon-based programming, the detail of flowcharting required is reduced because functions are built into the authoring tool. The icon-based timeline created is very much like a flowchart. Logic is checked by mentally running through the logic of the timeline or executing the portion of the program to be checked.

An Authoring tool's greatest advantage is its ability to develop interactive multimedia applications. The creation of an application with a nonlinear structure allows the learner the ability to determine the order that topics are covered (Alessi & Trollip, 1991). For example, the learner can use a Windows-like, pull-down menu to navigate through the application. Also by providing hypertext cues the learner can view amplifying information related to the current topic.

b. Animation Software

Two animation tools were used in the development of animation for this application. The first and least complex are the animation features built into Authorware. These features allow the creation of two-dimensional (2D) images and the animation of those images or visual cues such as arrows, lines, or imported images. The other method

used to create animation is 3D Studio by Autodesk, a three-dimensional (3D) graphics and animation package. This package is a DOS-based program, which has a rendering capability superior to a Windows version. Additionally, this package can create more realistic animations and graphics than can be created with Authorware. However, the tool is very complex for a beginner and requires a tremendous amount of practice and artistic ability to take full advantage of the program's capabilities.

Another animating tool that was evaluated early in the development process was Caligari's Truespace 1.0. This tool has functionality similar to Autodesk's 3D Studio. However, since each tool requires extensive practice and experimentation, the decision was made to select one tool for the creation of 3D images and animation. The best feature of Truespace is that it is a Windows-based program, therefore the graphical user interface is more appealing to the developer. However, the disadvantage of using a Windows-based application is the loss of computer performance. For example, the rendering of a 3D animation can take thirty minutes. If changes in the animation are needed, additional computer delays prolong development. The major advantage of 3D Studio over Truespace is the ability to show four viewports (e.g., top, left, right, bottom) simultaneously. On the other hand, Truespace limits the user to see a 3D view that the developer can rotate to view different aspects. Developing 3D images requires an ability to control the image in a two-dimensional plane so that a smooth consistent surface is created. This capability is very valuable, especially for a novice.

3. Limitations

Several hardware and software limitations were considered during the development of the application. For example, most PCs today are capable of 256 colors. However, many computers are also capable of 32,000 or more colors. During development, consideration must be given to the user's computing capabilities. Therefore, when deciding how many colors to incorporate into animations, a balance must be found between the computing capability of potential users and the visual quality of the animations. These two factors oppose each other. The decision was made to create an

application that is highly transferable between potential users. Therefore, animations were created with the intention of running on a PC using 256 colors.

C. DEVELOPMENT PROCESS

This section provides a description of the development process used in the creation of animations for the application. It must be understood that the production of this or any multimedia instructional tool cannot be accomplished by focusing on a single form of media such as animation. An effective multimedia presentation integrates the different media forms (Howles & Pettengill, 1993). The structured development processes for computer-based instruction presented by Alessi and Trollip (1991) and Howles and Pettengill (1993) were adapted to the development of this application. However, in practice much of the early work on this application was centered around experimentation with multimedia software and hardware as well as gaining knowledge on NVGs rather than determining a methodology to follow during the development process. Therefore, by not strictly adhering to a model for the development of the application the development team was able to experiment and explore possibilities in a creative fashion.

1. Selection of Lessons for Multimedia Enhancement

Multimedia and animation cannot represent all aspects of the material that aircrews must learn about NVGs. Therefore, a logical starting place in the development process is determining what aspects of NVGs are good candidates for presentation through multimedia. Before beginning the selection of lessons, one must establish a perspective for the purpose of the training application (Alessi & Trollip, 1991). Is the application intended to act as an introductory lesson, a supplement to current training, or should the instruction be an all-inclusive trainer? For the NVG application the perspective established is that the application will supplement other forms of training by reinforcing NVG limitations and visualization skills.

Theoretically, the basis for selecting lessons should be to promote learning as discussed in the earlier chapters. However, in practice the selection of material appropriate for representation by multimedia was largely based on the availability of

video, graphics and NVG training material. Availability of instructional material to incorporate into an application is a factor that should not be under emphasized. During the implementation of this application, availability of resources was one of the largest stumbling blocks in selecting lessons for multimedia enhancement. Therefore, the Marine Corps Night Vision Goggle Manual became an invaluable guide in determining what topics are considered relevant to the instruction of NVGs.

2. Establish Learning Objectives

Establishing learning objectives provides the developer an outline of the subject matter that the instruction should contain. The objectives can be thought of as targets for learning. The instruction created should support the learning objectives in its content and presentation (Howles & Pettengill, 1993). It is important to establish a learning objective that is short and concise, such as: the learner will name and describe the adjustment components of the Cats Eye NVGs. This objective is easily interpreted by the developer. Using clear objectives, especially in multimedia, can keep the developer focused on the learning outcomes rather than the glitz of the graphics, sounds, and animations. Therefore, the tools of multimedia are utilized in support of the learning objectives rather than letting multimedia become the focus.

3. Selection of Media

Due to the nature of multimedia, development requires an integrated approach. No single media can be pursued without considerations for alternative media. Though this thesis studies animation within a multimedia training tool, animation is only a portion of the media considered. From the analysis of the collected data, modules were created based on learning objectives. Each module utilizes the media forms that can best satisfy the learning objective.

a. Why Animation?

After the selection of material for multimedia enhancement, the principles of Chapter II regarding instructional conditions for the use of animation were applied. During the early stages of applying animation to modules, the focus was to identify

material that cannot be captured by other media. For example, animation is the only media that can provide a visual representation of the dynamic nature of photons traveling through the NVG amplification tube. However, after working with other modules that did not use animation, it became apparent that some of these modules could be enhanced with the addition of animation. The enhancements often guide the learner's attention to significant material displayed or provide a visual representation to reinforce verbal instruction.

Often an animation only emphasizes a portion of the learning objective. No module created using animation could satisfy a learning objective without the addition of another form of media. For example, animation may illustrate the characteristics of motion and trajectory however, other aspects such as materials of construction must be represented by another form of media. The addition of audio is especially useful when used in coordination with animation. For example, when depicting the process that occurs within the NVG's photo intensifier tube many of the dynamic aspects can be represented by animation. However, verbal explanation of what is occurring adds clarity and can enhance the coding of the information by providing visual and verbal stimuli (Mayer & Anderson, 1991).

4. Flow Charting

Flow charting is a design tool that is used to determine the sequence and the structure of the application that the computer will execute (Alessi & Trollip, 1991). Authorware's timeline and icon-based interface automates much of the flowcharting that must be done. Figure 2 is an example of a timeline that contains the animation for the adjustment of the Cats Eye Interpupillary Distance (IPD). The graphical development environment makes it much easier to check the logic of the module. Before the displays are actually created, the timeline that forms a module's logic and progression is established. This flowcharting method is an iterative process of changing and verifying. Once the sequencing of a module is established, one can direct attention to the construction of displays.

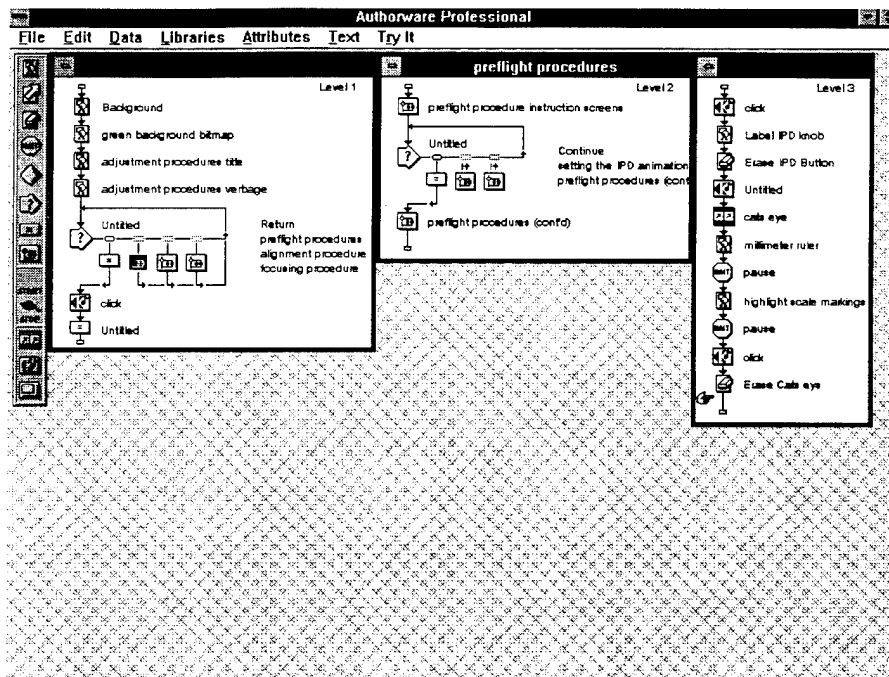

Figure 2. Authorware Timeline.

5. Storyboarding

After flowcharting is performed, one needs storyboards to develop the displays that the learner is actually going to see. Storyboarding is done by designing the displays on paper or on the computer consisting of the text, graphics, or areas for animation or video. The intent of creating the storyboard is to display the content of the display screens prior to implementing them in the application. From these storyboards a preliminary evaluation is made of the display's quality, accuracy, and content. The evaluation of these storyboards are best done by potential students of the instruction. From this independent evaluation, ambiguities and errors can be identified. (Alessi & Trollip, 1991)

When creating an animation the storyboard is a visualization aid for the developer to determine which components will move and how they will move. Another advantage of using storyboards is that they can aid in selecting the appropriate media in the first

place. For example, initially one may think that a lesson can be taught with animation only to discover after storyboarding that this is impractical due to the complexity. Learning objectives can also be found to be too broad, attempting to convey too many concepts in one module.

In the development of animation for this application, two methods of storyboarding were used. The first and most basic method is to create sketches on paper. The other more complex method is to create a rough of the object in 3D Studio. This rough is imported into the keyframer environment and the appropriate components are animated. After animating the components, all the frames are played back without the need for rendering. The advantage is that the developer can see a rough animation without waiting for the long rendering process.

6. Lesson Production

Since much of the NVG development process was based on the discovery of new techniques while building the prototype, modules that were selected to be represented by a form of media had to be changed during the development process. For example, during the early stages of developing the application the team felt that an animated representation of a pilot's vision in different illumination levels would be possible. However, as experience was gained it became apparent that this was too ambitious for the scope of this thesis.

a. Creation of an Animation

As stated earlier, animations were created using Authorware and 3D Studio. Figure 3 is an example of a animation created in 3D studio that is used in the calibration module to demonstrate the IPD adjustment. The animation shows how turning the IPD Adjustment Knob affects the position of the objective lens. The goggles are created using basic shapes and customized shapes. The basic shapes like a 3D block are easily created using built-in functions. The customized shapes like the lens and the objective focus ring base are created first as a 2D image. Then, by applying a lofting function, the 2D image is transformed into 3D. This figure shows a front 2D view of the goggles since the IPD

adjustment occurs in a 2D plane. The animation of the goggles in Figure 3 is created using the keyframing environment within 3D Studio. While designing this animation a decision was made on how many frames to render. The first option is to render many frames and create a smooth, short animation that takes up several megabytes of hard disk space. The second option is to render relatively few frames creating a slower and choppy animation that takes up less disk space. It was decided to render the fewer frames and evaluate how the animation performed within the module. As the animation was rendered it was saved to disk as a *flic* (FLC) format file. A *flic* is a series of frames or an animation. Authorware can import these files using the Presentation Window icon. Within this icon, the speed of the animation in frames per second can be set. This setting is useful to adjust the length of the animation so that other media can be coordinated with the playing of the animation.

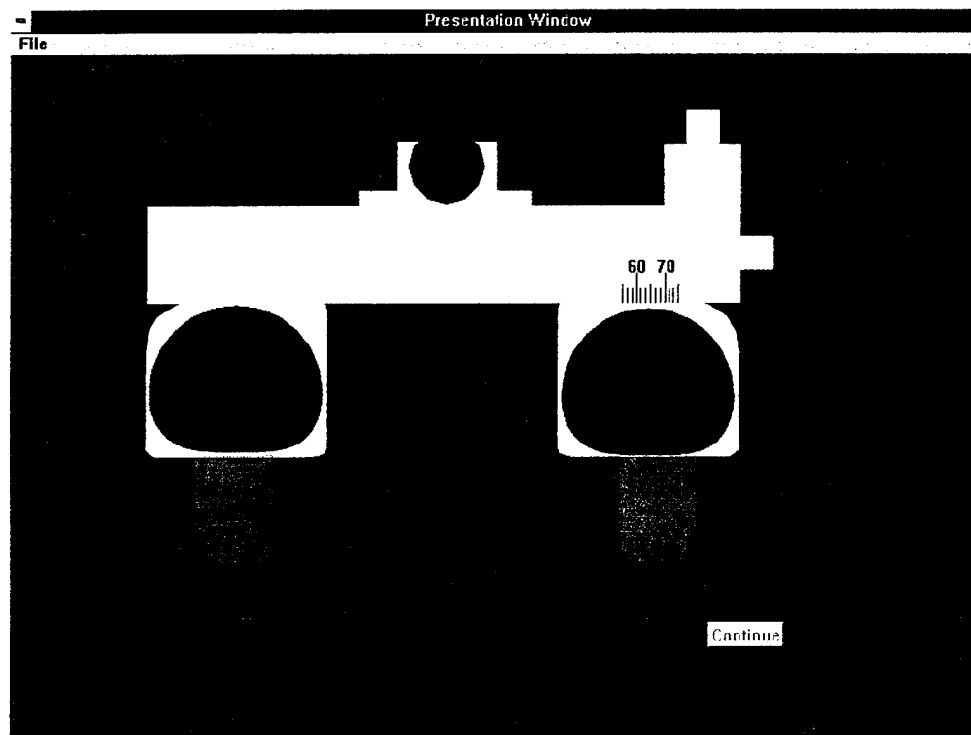

Figure 3. IPD Adjustment Animation.

Figure 4 is an example of an animation created within Authorware. This animation illustrates the operation of the lens as the distance between objects and the lens of the eye varies. The animation of the aircraft in the figure is done by importing a *bitmap* (BMP) image of the aircraft and specifying the path of travel for the aircraft. This function is incorporated into the animation icon within Authorware. The size of a BMP is altered by re-sizing the frame containing the BMP. To illustrate the changing thickness of the lens, a series of display and erase icons are used to give the appearance of the lens becoming thicker as the aircraft approaches. The animation in Figure 4 is an example for which 2D animation is adequate. The complexity of a 3D animation is not required in this instance to illustrate the learning objectives regarding eye anatomy.

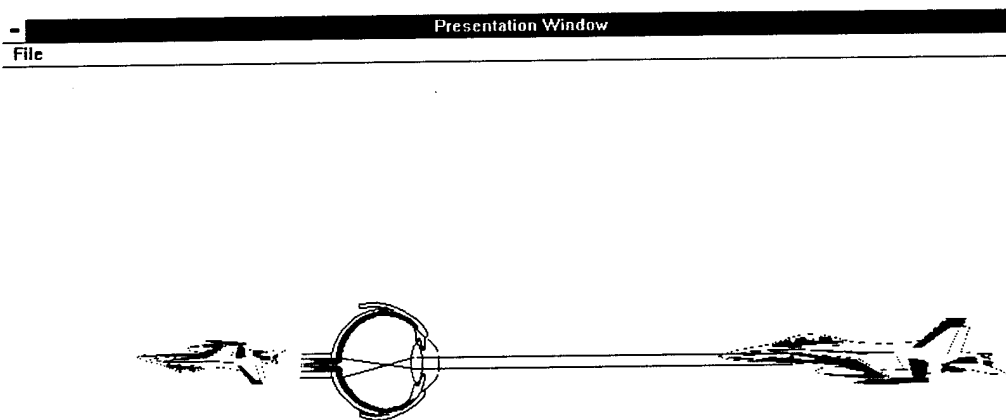

Figure 4. Eye Anatomy Animation.

b. The use of Animation with other media

From animating the NVG material, it was determined by the development team that using only animation could not convey all the required objectives. Most often we found that animation was more effective in satisfying a learning objective if applied in support of a module rather than as the center of the delivery of instruction. For example, in a module describing the phases of the moon, animation was used to act as visual support for text. This allows the learner to refer to the animation for illustration when necessary. Figure 5 is the first screen describing the quarter moon. As the learner reads the text, an association can be created between the text and the rotating moon. Based on the dual-coding theory, this should improve recall of this information since both verbal and visual representations are provided.

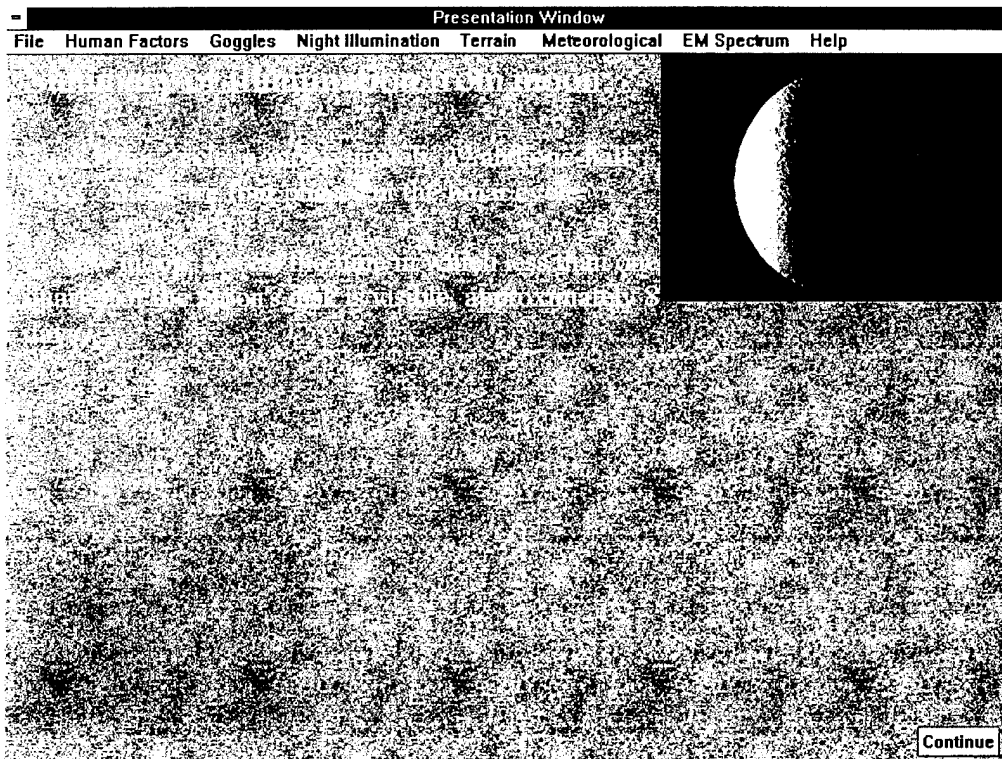

Figure 5. Animation used as a cue for text.

Figure 6 is a frame from an animation describing the principles of operation for an image intensifier tube. With animation, the dynamics of photo-multiplication are captured. Without animation, providing a visual representation of the multiplication of electrons through the microchannel plate is impossible. However, without the addition of voice, the learner would have a difficult time understanding the principles presented by animation alone. The coordinated presentation of animation and sound assists the learner in creating connections between the verbal and visual representations.

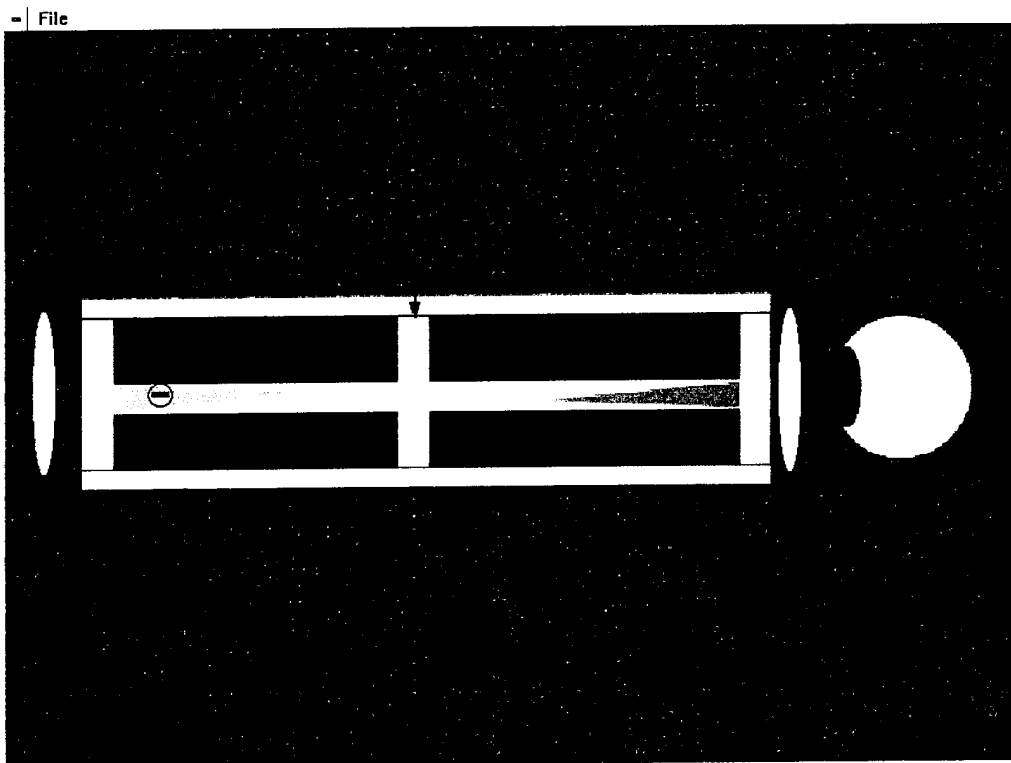

Figure 6. Animation and sound.

IV. RECOMMENDATIONS AND CONCLUSIONS

The purpose of this thesis was to determine the extent to which animation can be utilized within a multimedia system to enhance aircrew NVG skills. To answer this question a review of fundamental instructional design principles and prior research in the area of animation was performed. By following fundamentally sound design guidelines for the instructional roles and conditions for the use of animation a capability should exist to create more effective multimedia instruction using animation. The knowledge gained from this review was applied to the development of a Windows-based multimedia training prototype for NVGs.

A. RECOMMENDATIONS

After this experience of developing animation for a multimedia training prototype for NVGs, there are several recommendations that can be documented for follow-on research. The following recommendations will aid researchers in applying animation and creating better presentations for multimedia instruction.

Due to the nature of developing a prototype, there is a temptation to not strictly follow a development process. However, for the development of a final product, a strict methodology must be enforced. Placing more emphasis on configuration management is crucial to creating an application that provides the capability of easy maintenance and modification. If an investment in design is not made at the beginning of development, the remainder of the process becomes an exercise in revision control. Late changes in the development process are much more difficult and time consuming.

Developers of multimedia training applications are at a significant disadvantage if they are not trained on the subject matter for which they are creating an application, or are not assisted by a subject matter expert. Though the requirement for familiarity with the technical aspects of multimedia is first and foremost, expert domain knowledge is critical

for the developer's competence to ensure that the content of the instructional application is sufficient and correct.

When developing animation for an application, the temptation exists to include impressive animations regardless of learning content. Unless there is justification for an animation based on the instructional conditions and roles, one should leave the animation out of the application. For example, during development an introductory animation of a spinning logo of the acronym NVG was included. After viewing this animation several times, the animation becomes an irritant and one loses interest. The intention for the logo was to impress the learner through providing an interesting introduction. However, if the learner repeatedly has to wait for this animation, which contains no learning value, the opposite effect can result with the learner losing motivation.

During the development of animations there is an enticement to create complex 3D representations. However, the effort directed towards the creation of 3D animation is often at the expense of incorporating content. The overriding goal of implementing animation in an instructional tool is to satisfy learning objectives, but the development of any application has a time constraint. Consideration must be given to the merits of creating a 3D animation when a 2D animation may provide effective instruction with reduced development time.

B. CONCLUSIONS

Based on this study of the feasibility of using animation within a multimedia system to enhance aircrew NVG skills, animation is a promising yet still unproven presentation media. This research has successfully implemented animations of NVG training material into a multimedia training application. However, further research is needed to conclusively determine the value of animation in comparison to other media in the delivery of effective instruction. Additionally, there are no evaluation measures for determining the effectiveness or the applicability of animation.

The implementation of animation in a multimedia training tool can take many forms. Each animation, from the most basic to the most complex, must support the learning objectives. The time limitations involved in the development of this prototype prevented the creation of animations involving terrain and other very complex representations. However, animation has been demonstrated as a valuable visual tool for many aspects of the NVGs that require an understanding of the principles of operation, procedural tasks, and a visual representation of information that cannot be captured from another form of media such as video.

Though multimedia is becoming more widely utilized as an instructional tool, one cannot forget to acknowledge that traditional methods of instruction can produce superior results. For example, an aircrew may improve their visual skills to a larger degree in a NITE Lab rather than sitting in front of a computer. Often there is no better training than actually practicing in the nighttime environment. However, these options are not always available and a tool like the Night Vision Goggle Multimedia training application is a promising alternative.

Finally, the most important facet regarding the extent to which animation can be utilized in a multimedia instructional tool is the requirement to adhere to sound instructional design principles. Unfortunately, multimedia and animation are still perceived solely as developing technologies rather than presentation methods. The potential of animation and multimedia rests on the utilization of these technologies based on a sound foundation of instructional design principles.

LIST OF REFERENCES

Alessi, Stephen M., & Trollip, Stanley R., Computer-Based Instruction, Englewood Cliffs, Prentice Hall, 1991.

Baek, Young K., Layne, Benjamin H., Color, Graphics, and Animation in a Computer-Assisted Learning Tutorial Lesson, *Journal of Computer-Based Instruction*, Vol. 15, No. 4, pp. 131-135, Autumn 1988.

Blattner, Meera M., & Dannenberg, Roger B., Multimedia Interface Design, ACM Press, 1992.

Bryant, Bobby, & Day, Glenroy E., A Computer-Based Multimedia Prototype For Night Vision Goggles, Master's Thesis, Naval Postgraduate School, Monterey, CA, September 1994.

Ciavarelli, Anthony, Sengupta, Kishore, & Baer, W., Night Vision Goggle (NVG) Training Technology Study (Draft), Naval Postgraduate School, Monterey, CA, September 1994.

Clark, James M., & Paivio, Allan , Dual Coding Theory and Education, *Educational Psychology Review*, Vol. 3, No. 3, pp. 149-210, 1991.

Falk, Dennis R., & Carlson, Helen L., Learning to Teach With Multimedia, *Technological Horizons in Education Journal*, Vol. 20, No. 5, December 1992.

Filbert, Dorothy L., Weatherspoon, Jamel B., Cognitive Psychology and Design Paradigms in the Development of Multimedia Courseware, Master's Thesis, Naval Postgraduate School, Monterey, CA, September 1993.

Fletcher, J. D., Effectiveness and Cost of Interactive Videodisc Instruction in Defense Training and Education, Institute for Defense Analysis, July 1990.

Forgus, Ronald H., Perception, McGraw-Hill, New York, NY, 1966.

Gagne, Robert M., & Briggs, Leslie J., Principles of Instructional Design, Holt, Reinhart and Winston, 1979.

Goldstein, Irwin L., Training in Organizations Needs Assessment, Development, and Evaluation, Brooks/Cole, Pacific Grove, CA, 1993.

Gotz, Klaus, Interactive Learning with the Computer, *Educational and Training Technology International*, Vol. 28, No. 1, pp. 7-14, February 1991.

Howles, Les, & Pettengill, Connie, Designing Instructional Multimedia Presentations: A Seven- Step Process, *Technological Horizons in Education Journal*, pp. 58-61, June 1993.

Macromedia, Inc., Authorware Professional, 2nd ed., June 1993.

Marine Aviation Weapons and Tactics Squadron One (MAWTS-1), Helicopter NVG Manual, July 1993.

Mayer, Richard E., & Anderson, Richard B., Animations Need Narration: An Experimental Test of a Dual-Coding Hypothesis, *Journal of Educational Psychology*, Vol. 83, No. 4, pp. 484-490, 1991.

Mayton, Gary B., Learning Dynamic Processes from Animated Visuals in Microcomputer-Based Instruction, Proceedings of Selected Research Presentations at the Annual Convention of the Association for Educational Communications and Technology, 1991.

Park, Ok-Choon, & Hopkins, Reginald, Instructional conditions for using dynamic visual displays: a review, *Instructional Science*, Vol. 21, pp. 427-449, 1993.

Rieber, Lloyd P., Animation in Computer-Based Instruction, *Educational Technology Research and Development*, Vol. 38, No. 1, pp. 77-86, 1990a.

Rieber, Lloyd P., Animation, Incidental Learning, and Continuing Motivation, *Journal of Educational Psychology*, Vol. 83, No. 3, pp. 318-328, 1991a.

Rieber, Lloyd P., The Effects of Visual Grouping on Learning From Computer Animated Presentations, Proceedings of Selected Research Presentations at the Annual Convention of the Association for Educational Communications and Technology, 1991b.

Rieber, Lloyd P., Using Computer Animated Graphics in Science Instruction With Children, *Journal of Educational Psychology*, Vol. 82, No. 1, pp. 135-140, 1990b.

Rieber, Lloyd P., & Boyce, Mary J., & Assad, Chahriar, The Effects of Computer Animation in Adult Learning and Retrieval Tasks, *Journal of Computer-Based Instruction*, Vol. 17 No. 2, pp. 46-52, Spring 1990.

Rieber, Lloyd P., Kini, Asit S., Theoretical Foundations of Instructional Applications of Computer-Generated Animated Visuals, *Journal of Computer-Based Instruction*, Vol. 18, No. 3, pp. 83-88, Summer 1991.

Sprague, Ralph H. Jr., & McNurlin, Barbara C., Information Systems Management in Practice, Third Edition, Prentice Hall, Englewood Cliffs, NJ, 1993.

Wetzel, C. Douglas, & Radtke, Paul H., & Stern, Hervey W., Instructional Effectiveness of Video Media, Lawrence Erlbaum Associates, 1994.

INITIAL DISTRIBUTION LIST

	Number of Copies
1. Defense Technical Information Center Cameron Station Alexandria, Virginia 22304-6145	2
2. Library, Code 52 Naval Postgraduate School Monterey, California 93943-5101	2
3. Kishore Sengupta, Code SM/SE Department of Systems Management Naval Postgraduate School Monterey, California 93943-5002	1
4. Alice Crawford, Code SM/CR Department of Systems Management Naval Postgraduate School Monterey, California 93943-5002	1
5. Anthony Ciavarelli, Code 34 Aviation Safety Program Naval Postgraduate School Monterey, California 93943-5002	1
6. Balasubraniam Ramesh, SM/RA Department of Systems Management Naval Postgraduate School Monterey, California 93943-5002	1
7. LT Sean Epperson 4013 Ferry Landing Road Alexandria, Virginia 22309	2