

# NAVAL POSTGRADUATE SCHOOL Monterey, California

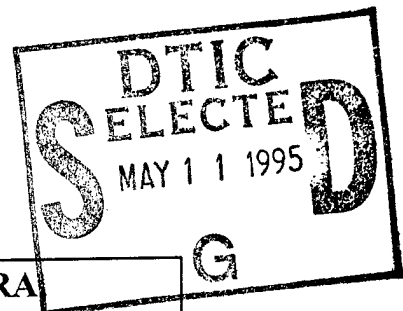

**THESIS**



**A REAL-TIME, SINGLE-CAMERA  
STEREOSCOPIC VIDEO DEVICE**

by

Blake L. Converse

December 1994

Thesis Advisor:

David D. Cleary

Co-Advisor:

Oscar Biblarz

Approved for public release, distribution is unlimited.

19950510 036

DTIC QUALITY INSPECTED 3

REPORT DOCUMENTATION PAGE			Form Approved OMB No. 0704	
Public reporting burden for this collection of information is estimated to average 1 hour per response, including the time for reviewing instruction, searching existing data sources, gathering and maintaining the data needed, and completing and reviewing the collection of information. Send comments regarding this burden estimate or any other aspect of this collection of information, including suggestions for reducing this burden, to Washington headquarters Services, Directorate for Information Operations and Reports, 1215 Jefferson Davis Highway, Suite 1204, Arlington, VA 22202-4302, and to the Office of Management and Budget, Paperwork Reduction Project (0704-0188) Washington DC 20503.				
1. AGENCY USE ONLY (Leave blank)		2. REPORT DATE December 1994	3. REPORT TYPE AND DATES COVERED Master's Thesis	
4. TITLE AND SUBTITLE A REAL-TIME, SINGLE-CAMERA, STEREOSCOPIC VIDEO DEVICE			5. FUNDING NUMBERS	
6. AUTHOR(S) Converse, Blake L.				
7. PERFORMING ORGANIZATION NAME(S) AND ADDRESS(ES) Naval Postgraduate School Monterey CA 93943-5000			8. PERFORMING ORGANIZATION REPORT NUMBER	
9. SPONSORING/MONITORING AGENCY NAME(S) AND ADDRESS(ES)			10. SPONSORING/MONITORING AGENCY REPORT NUMBER	
11. SUPPLEMENTARY NOTES The views expressed in this thesis are those of the author and do not reflect the official policy or position of the Department of Defense or the U.S. Government.				
12a. DISTRIBUTION/AVAILABILITY STATEMENT  Approved for public release; distribution unlimited			12b. DISTRIBUTION CODE	
13. ABSTRACT (maximum 200 words)  A real-time, single-camera, stereoscopic video imaging device for use with a standard 60 Hz camera and monitor is being developed. The device uses a single objective lens to focus disparate views of the object at the focal plane of the lens. Each view is represented by a set of parallel rays emanating from the object at a specific angle. The lens focuses these parallel rays to a single point at the focal plane. These views are then shuttered at the focal plane using a Liquid-Crystal Device (LCD) shutter such that one view at a time is passed to the camera. The camera then transmits alternating video fields (individual TV images) to the monitor, such that alternate fields display stereoscopically-related views of the object being imaged. The user views the monitor using off-the-shelf LCD stereoglasses, modified to allow synchronization with the standard field rate of the camera and monitor. The glasses shutter the light alternately to each eye so that the left eye views the left-hand image and the right eye views the right-hand image. The resulting 3-D image is independent of the user's viewing angle or distance from the monitor.				
14. SUBJECT TERMS  Stereoscopy, Stereovision, Three-Dimensional Imagery, Alternating-field Stereoscopy.			15. NUMBER OF PAGES 66	
			16. PRICE CODE	
17. SECURITY CLASSIFICATION OF REPORT  Unclassified	18. SECURITY CLASSIFICATION OF THIS PAGE  Unclassified	19. SECURITY CLASSIFICATION OF ABSTRACT  Unclassified	20. LIMITATION OF ABSTRACT  UL	



Approved for public release, distribution is unlimited.

**A REAL-TIME, SINGLE-CAMERA,  
STEREOSCOPIC VIDEO DEVICE**

Blake L. Converse  
Lieutenant, United States Navy  
B.S, Pennsylvania State University, 1987

Submitted in partial fulfillment  
of the requirements for the degree of

**MASTER OF SCIENCE IN ASTRONAUTICAL ENGINEERING**

and

**MASTER OF SCIENCE IN APPLIED PHYSICS**

from the

**NAVAL POSTGRADUATE SCHOOL  
December 1994**

Author:

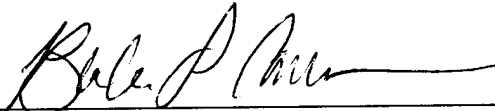

Blake L. Converse

Approved by:

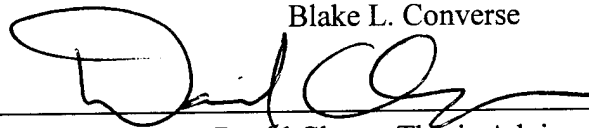

David Cleary, Thesis Advisor

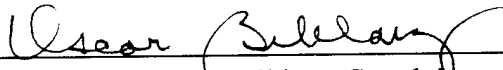

Oscar Biblarz, Co-advisor

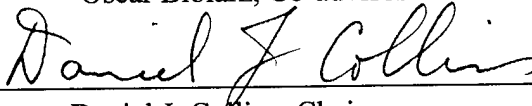

Daniel J. Collins, Chairman

Department of Aeronautical/Astronautical Engineering

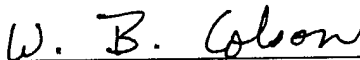

William B. Colson, Chairman

Department of Physics

Accession For	
NTIS CRA&I	<input checked="" type="checkbox"/>
DTIC TAB	<input type="checkbox"/>
Unannounced	<input type="checkbox"/>
Justification .....	
By .....	
Distribution /	
Availability Codes	
Dist	Avail and/or Special
A-1	

## ABSTRACT

A real-time, single-camera, stereoscopic video imaging device for use with a standard 60 Hz camera and monitor is being developed. The device uses a single objective lens to focus disparate views of the object at the focal plane of the lens. Each view is represented by a set of parallel rays emanating from the object at a specific angle. The lens focuses these parallel rays to a single point at the focal plane. These views are then shuttered at the focal plane using a Liquid-Crystal Device (LCD) shutter such that one view at a time is passed to the camera. The camera then transmits alternating video fields (individual TV images) to the monitor, such that alternate fields display stereoscopically-related views of the object being imaged. The user views the monitor using off-the-shelf LCD stereoglasses, modified to allow synchronization with the standard field rate of the camera and monitor. The glasses shutter the light alternately to each eye so that the left eye views the left-hand image and the right eye views the right-hand image. The resulting 3-D image is independent of the user's viewing angle or distance from the monitor.

## TABLE OF CONTENTS

I. INTRODUCTION .....	1
A. THESIS OBJECTIVES .....	2
1. Description of a Real-time, Single-camera, Stereoscopic Video Device .....	2
2. Current Testing and Research .....	3
B. THESIS OUTLINE .....	4
II. BACKGROUND .....	5
A. HUMAN VISUAL PERCEPTION IN THREE-DIMENSIONAL SPACE ..	5
1. The Physiology of Binocular Stereopsis .....	6
2. Flicker and Intermittent Stimulation .....	9
3. Creating Stereopsis From a Two-dimensional TV Image .....	11
B. THE IMPORTANCE OF BINOCULAR STEREOSCOPY .....	12
1. The Need for Binocular Vision .....	12
2. Tasks Which Require Stereoscopic Video .....	13
3. Tasks Which are Easier with Stereoscopic Video .....	14
C. APPLICATIONS OF A REAL-TIME, SINGLE-CAMERA, STEREOSCOPIC VIDEO DEVICE .....	15
1. Space Applications .....	15
2. Terrestrial Applications .....	16
D. A SURVEY OF STEREOSCOPIC VIDEO TECHNOLOGY .....	17
1. Stereoscopy in Entertainment .....	17
2. Stereoscopy in War .....	18
3. 3-D Video Technology .....	18
a. Stereoscopic Video Systems .....	19
b. Autostereoscopic Video Systems .....	21

III. DESIGN OF A 3-D VIDEO IMAGING DEVICE .....	23
A. ALTERNATING-FIELD 3-D VIDEO THEORY .....	23
1. Lens Theory .....	23
2. Lens System Description .....	24
3. Producing a Stereoscopic Video Image .....	25
4. Summary of Alternating-field Video Stereoscropy .....	25
B. ELECTRO-MECHANICALLY SHUTTERED STEREO SCOPIC SYSTEMS .....	26
1. Chopper Wheel Shuttering System .....	26
2. Chopper Wheel Shutter with Stereoglasses .....	27
C. LCD SHUTTERING SYSTEM WITH STEREOGLASSES .....	29
1. Lens Assembly .....	30
2. LCD Shutter Assembly .....	30
a. LCD Shutter Theory .....	31
b. LCD Shutter Design .....	31
c. Focal Plane Mask .....	34
3. Integrated Lens and Shutter Assembly .....	34
4. Stereoglasses .....	34
5. Synchronizing Circuit .....	36
a. Synchronization of the Stereoglasses with the Monitor .....	36
b. Synchronization of the LCD Shutter with the Camera .....	38
IV. RESULTS .....	41
A. TESTING OF THE PROTOTYPE STEREO SCOPIC DEVICE .....	41
B. PROBLEMS ENCOUNTERED DURING TESTING .....	41
1. Shadow Images in the Video Picture .....	41
2. Flicker in the Video Picture .....	42
3. Transmission Losses Through the Shuttering Mechanism .....	43

V. CONCLUSIONS & RECOMMENDATIONS .....	45
A. CONCLUSIONS .....	45
B. RECOMMENDATIONS FOR FUTURE RESEARCH .....	45
APPENDIX. COMPUTER CODE FOR SYNCHRONIZING CIRCUIT .....	47
LIST OF REFERENCES .....	51
INITIAL DISTRIBUTION LIST .....	55



## LIST OF FIGURES

1-1. Schematic of a Single-camera Stereoscopic Video Device .....	3
2-1. A Diagram of the Right Eye in Cross-section, and a Plan View of the Central Visual Pathway from the Eyes to the Brain .....	7
2-2. Simple Depth Perception Test .....	9
2-3. Graph of CFF Versus Illuminance .....	10
2-4. Charles Brewster's Stereoscope .....	18
2-5. Stereographics 3-D Video System .....	19
2-6. Single-channel, Spatial Multiplexing System .....	20
2-7. Single-camera, Color Multiplexing Scheme with Colored Glasses .....	21
2-8. Autostereoscopic Stereo-pair Systems .....	21
3-1. Simple Lens Analysis Using Ray Tracing .....	24
3-2. Overhead View of a General Single-camera Alternating-field Device .....	25
3-3. Top View Schematic of the Chopper Wheel Shuttering System .....	27
3-4. Schematic of DC Shutter Motor Control Circuit .....	28
3-5. Top View of Chopper Wheel Shutter Device Used with Stereoglasses .....	29
3-6. Schematic of the Single-camera, Stereoscopic Video Device .....	30
3-7. A Sketch of a Light-twisting LCD Shutter .....	31
3-8. Schematic of the LCD Shutter, Showing Both States of the Device .....	32
3-9. Photograph of the LCD Shutter Device and Casing .....	33
3-10. Computer Simulation of the Transmission Versus Wavelength Characteristic for the Zoned LCD Shutter Used in the Stereoscopic Video Device .....	33
3-11. Photograph of Electro-optical Shuttering Device on an Optical Rail .....	35
3-12. Block Diagram of Synchronization Circuit and Timing Diagrams Showing the Control Signals Developed by the Circuit .....	37

## I. INTRODUCTION

The advent of modern video equipment has allowed real-time, remote imagery in environments as distant and extreme as outer space and the Moon. These videos have necessarily been two-dimensional (2-D) because of the nature of the camera system and the monitors on which the image is displayed. This provides adequate visual acuity for entertainment and most remote information gathering applications; however, many tasks are much more difficult or nearly impossible to perform with only 2-D visual cues. For these tasks, stereoscopic imagery provides the answer.

*Stereoscopic*, or three-dimensional (3-D), imagery has been shown to provide significant improvements in time-to-task-completion, visual perception of the remote scene, and object detection and recognition during delicate teleoperation tasks using a remote manipulator [Ref. 1]. In addition, some remote teleoperation tasks have been found to be impossible without 3-D video feedback [Refs. 2,3].

Recent advances in Liquid-Crystal Device (LCD) shutter technology have provided the impetus for a proliferation of stereoscopic devices that operate with two lenses and two cameras [Refs. 4,5,6,7]. Such devices can be time-multiplexed at twice the National Television System Committee (NTSC) standard field rate to provide alternating video fields (TV screen images) to a specially designed monitor in a process known as '*alternating field technology*'. The 3-D image is perceived when the monitor is viewed with LCD stereoglasses.

Although this system has been used in numerous applications with great operational success, it does have significant limitations. The two-camera system requires a larger communications bandwidth than the standard single NTSC video signal, limiting its application in extreme communications environments such as outer space, where increases in signal bandwidth are expensive and technically challenging to achieve. Also, either a special monitor and special cameras that operate at twice the NTSC video field rate, or a complex hardware and software unit must be used that stores, processes, and time-multiplexes the two images [Ref. 5]. Finally, in many remote working environments, there is simply not enough working space to effectively employ an instrument that requires

two cameras *and* two systems of lenses. For these reasons, the two-lens, two-camera stereoscopic video system has not found a strong foothold in many remote teleoperation fields.

## **A. THESIS OBJECTIVES**

This thesis presents the preliminary design of a real-time, single-camera, stereoscopic video system for use with NTSC standard cameras and video monitors. The objective of this research is to produce a viable alternative to two-camera stereoscopic devices currently available. The single-camera Stereoscopic Video Device (SVD) is intended for specific 3-D video applications not met by the current technology.

### **1. Description of a Real-time, Single-camera, Stereoscopic Video Device**

A real-time, single-camera, SVD has been developed for use with an NTSC standard camera and monitor. A schematic of the device is shown in Figure 1-1. An in-depth discussion of the theory of operation of the device is presented in Chapter III.

The system uses a state-of-the-art LCD shutter and a single camera to sequentially present alternating video fields (individual TV images) to the monitor. An image from the left-hand view of the object is displayed for one field, and the stereoscopically related right-hand view is displayed for the next field. The image fields are alternated at 60 Hz, which is the NTSC standard field rate for video cameras and monitors. The user views the monitor using off-the-shelf LCD stereoglasses, modified to allow synchronization with the standard field rate of the camera and monitor. The glasses shutter so that the left eye sees only the corresponding left-hand image and the right only the right-hand image. Because of the high field rate of the system, the brain does not interpret the inputs from the two eyes as separate images; rather, it fuses the two views into a single 3-D image in a process known as *stereopsis* (from the Greek words *stereos* meaning 'solid', and *opsis* meaning 'vision'). The resulting 3-D image is independent of the user's viewing angle or distance from the monitor.

The single-camera SVD is particularly well suited for near-field, precise, remote manipulations which use a single video camera for visual feedback. The entire imaging

device can be packaged in a cylindrical unit with a diameter under 6 mm, providing 3-D visual accessibility for medical optical devices, space applications, and remote undersea operations. In addition, the use of a single camera detector as the video acquisition device permits 3-D imagery under extremely remote conditions in which communications bandwidth is limited (such as occurs in space communications).

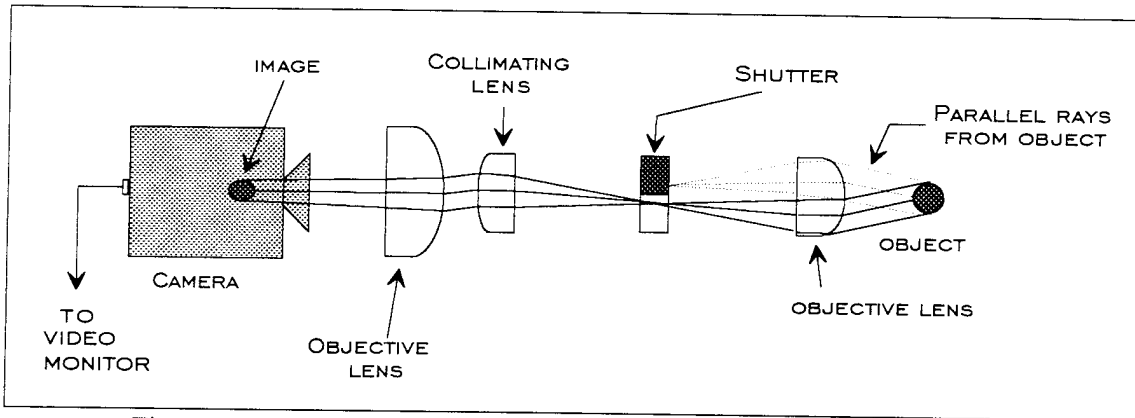

Figure 1-1. Schematic of a Single-camera Stereoscopic Video Device.

This schematic is an overhead view of the lens and shutter system for an SVD. Parallel rays emanating from the object at different angles with respect to the lens system centerline correspond to different views of the object. The disparate views of the object are focused by the objective lens to different points on the focal plane. The shutter passes only one set of views at a time to the camera detector.

Other advantages of the single-camera stereoscopic video system include the following: (1) the system works at the standard NTSC field rate to allow use with most popular cameras and monitors, (2) LCD technology is mature -- stereoglasses and LCD shutters are commercially available from at least two manufacturers, (3) the electronic circuitry to synchronize the LCD shutter, camera, monitor, and stereoglasses is inexpensive, readily available, and compact, and (4) no special hardware or software is necessary to time-multiplex the video signals.

## 2. Current Testing and Research

The SVD has been constructed in the lab and tested on an optical bench with mixed results. The SVD does produce a stereopsis effect for most users, but this effect is degraded by poor image quality due to camera detector problems, flicker on the video monitor, and LCD shutter transmission losses in our system.

Additional design challenges include interfacing the SVD with an endoscope for future testing, optimization and miniaturization of the synchronization circuit, redesign of the LCD shutter, and improvement of image quality.

## **B. THESIS OUTLINE**

This thesis contains five chapters and one appendix. Chapter II describes the physiological basis of stereoscopic vision including the need for binocular vision, applications of a single-camera SVD, and a history of stereoscopic devices. The optical theory and SVD design are presented in Chapter III. Results and future development considerations are detailed in Chapter IV. Finally, Chapter V presents a summary of the research performed and some suggestions for follow-on work in the field.

## II. BACKGROUND

This chapter presents the fundamentals of visual perception and the physics behind human depth perception. A discussion of early stereoscopic devices and trends in 3-D video imaging is provided as background for the development of a real-time, single-camera Stereoscopic Video Device (SVD). Finally, the applications of a single-camera SVD are discussed.

### A. HUMAN VISUAL PERCEPTION IN THREE-DIMENSIONAL SPACE

The ability to perceive depth through binocular stereopsis over a large field-of-view is a visual characteristic that humans share with a only small percentage of the animal kingdom. Binocular vision requires that both eyes view the same object simultaneously and that their visual fields (each about  $170^\circ$ ) overlap to a considerable extent. Although this seems rather trivial to humans, most animals have eyes on nearly opposite sides of their heads for *monocular*, or single eyed, panoramic vision and therefore have a very limited binocular field of view. Other animals with good binocular vision are cats, predatory birds, and primates. [Ref. 8]

One might wonder how individuals with only one eye can possibly perceive depth at all. It turns out that binocular vision is only one of several ways in which humans can judge depth; monocular cues such as *relative size*, *accommodation* (the muscular effort required to focus the eye), *shading*, and *motion parallax* (in which the relative motions of near and far objects differ) all can be quite helpful in establishing depth. Nevertheless, most of these are learned cues which depend upon some reference which is not always available. Binocular stereopsis is the only depth cue that is absolute, requires no previous knowledge of the object, and requires no relative motion between the observer and the object. Given these facts, it might seem that binocular stereopsis should be by far the most dominant of our depth perception cues; but, this is not always the case. Not everyone with binocular vision experiences stereopsis; about 2% of those with binocular vision have never experienced stereopsis in their day to day lives; another 10% perceive only limited stereopsis [Ref. 9]. Also, perception of depth is strongly influenced by cultural and

physiological background. Studies have shown widely varying stereopsis capabilities among individuals, and evidence suggests that practice and experience may play a large part [Ref. 8, 9]. One rather amusing example of these influences was reported by Colin M. Turnbull in 1961:

Turnbull was studying the forest pygmies of the Congo basin. His guide was a 22-year old pygmy called Kenge, who had spent his whole life in the forest, where visibility was limited to a few yards by vegetation. One day he left the forest with Turnbull. As they left the forest edge and drove across the savanna, a thunderstorm kept visibility to about 100 yards. When the rain stopped, some buffalo could be seen grazing in the distance. Kenge asked what kind of insects they were. When Turnbull explained that they were buffalo, twice as big as the forest buffalo known to Kenge, the pygmy laughed and told Turnbull not to tell stupid stories. On being driven closer to the animals, he was amazed to see that they were real buffalo, but thought Turnbull had used witchcraft to enlarge them. In an environment that restricted distance vision, he had never learned to judge size constancy at distances. [Ref. 9]

From this example, it is evident that depth perception is quite complicated, both physiologically and psychologically. It depends upon perceptions, visual interpretation, memory, and experience. Thus any design for a stereoscopic video device must be compatible with and closely simulate the natural stereopsis process to give good results. For this reason, a brief discussion of the physiology of binocular stereopsis follows.

### **1. The Physiology of Binocular Stereopsis**

Binocular stereopsis occurs when two views of an object from slightly different angles are collected by the eyes and fused in the brain. The resulting image developed in the mind is three-dimensional. Figure 2-1 shows a horizontal cross-section of the right eye, and a plan view of the central visual pathways in the brain. Each eye receives a different view of the object and focuses it on the *retina*, a concave surface at the back of the eye lined with nerve cells. Receptors in each retina collect the light and pass the image via optic nerve fibers to the opposite-side *cerebral cortex*, the section of the brain responsible for vision. As the optic fibers from each eye cross in the optic chiasma, there is an exchange of fibers, and about half of the fibers are routed to one side of the cerebral cortex

and the other half to the other side. This is the basis behind binocular stereopsis -- each side of the cerebral cortex actually receives signals from both eyes; by comparing the location of the respective receptors for each signal (on the retina), a three-dimensional image is perceived. [Ref. 8, 10, 11]

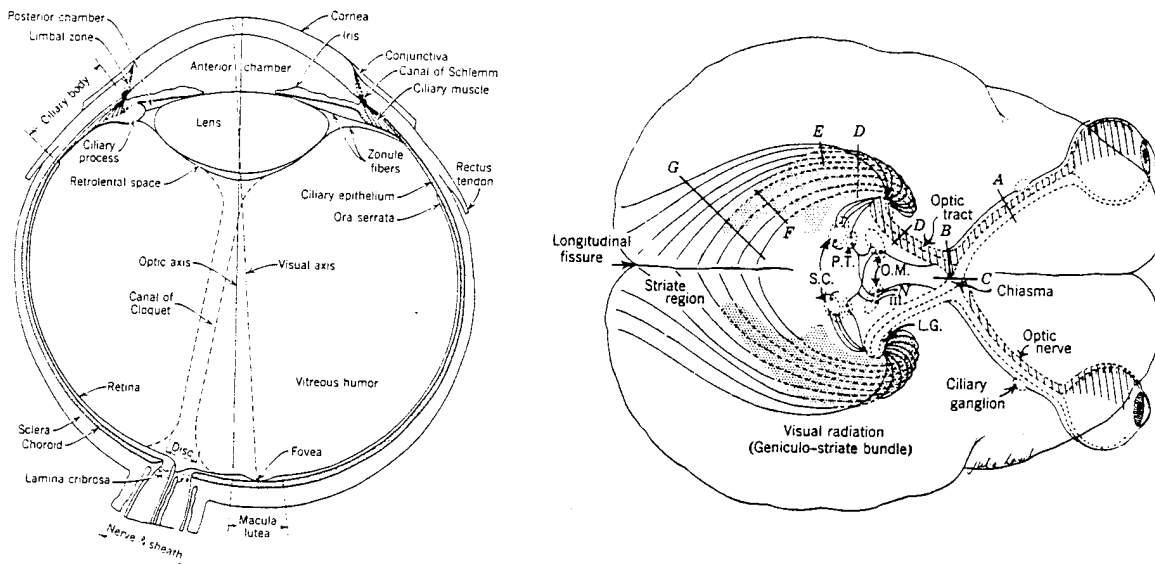

Figure 2-1. A Diagram of the Right Eye in Cross-section, and a Plan View of the Central Visual Pathway from the Eyes to the Brain [Ref. 11].

The problem of fusing the disparate images from the two eyes to form binocular vision has been debated since the ancient Greeks. Rene Descartes proposed in the 17<sup>th</sup> century that the optic fibers converged in the brain and were all analyzed together. While

this was incorrect, it did provide a basis for the unification of the two images in the brain. Isaac Newton finally solved the problem in 1704 with his proposal (now known to be correct) that there must be an interchange of fibers in the optic chiasma, where the optic nerves cross to pass to opposite sides of the cerebral cortex. This proposal laid the foundation for the concept of binocular stereopsis. The cerebral cortex simultaneously receives signals from *both* retinas. These separate images are compared and fused into a single image in the cortex. [Ref. 8]

The following example describes the process of stereopsis. Consider a depth perception test using two pencils held vertically at different depths from the observer, as shown in Figure 2-2. As each eye's *fovea* (the central high-resolution area of the retina) is directed toward the closer pencil, the image of that pencil is projected by the lens of the eye onto corresponding receptors in each retina. The two images are said to have zero *retinal disparity* and these signals are fused in the two sides of the cerebral cortex as one image with all points at the same depth. When the image of the more distant pencil is focused on the retina, the image falls on disparate receptors in each retina. The image from one retina is displaced horizontally from that on the other retina. The difference between the distances of the retinal images from the corresponding fovea is called the retinal disparity (this is the distance  $(d_2 - d_1)$  shown in Figure 2-2). The cerebral cortex receives the signals from the disparate receptors and, if the retinal disparity is not too large, interprets the disparity as a depth. [Ref. 8]

This process depends strongly on the distance of the object from the observer, the illumination of the object, and even the interpupillary distance (the distance between the pupils) of the observer. Interpupillary distance for most humans is between 50 to 74 mm., with the average being about 65 mm. [Ref. 10]. Based upon this fact, and the knowledge that the typical human eye can discriminate two objects at no smaller than 30 seconds of arc [Ref. 10], it is possible to calculate the limiting range for stereoscopic vision. This number turns out to be approximately 500 yards, or about a quarter of a mile [Ref. 11]. Although this number is influenced by several factors, it does indicate that stereopsis is possible over quite large distances.

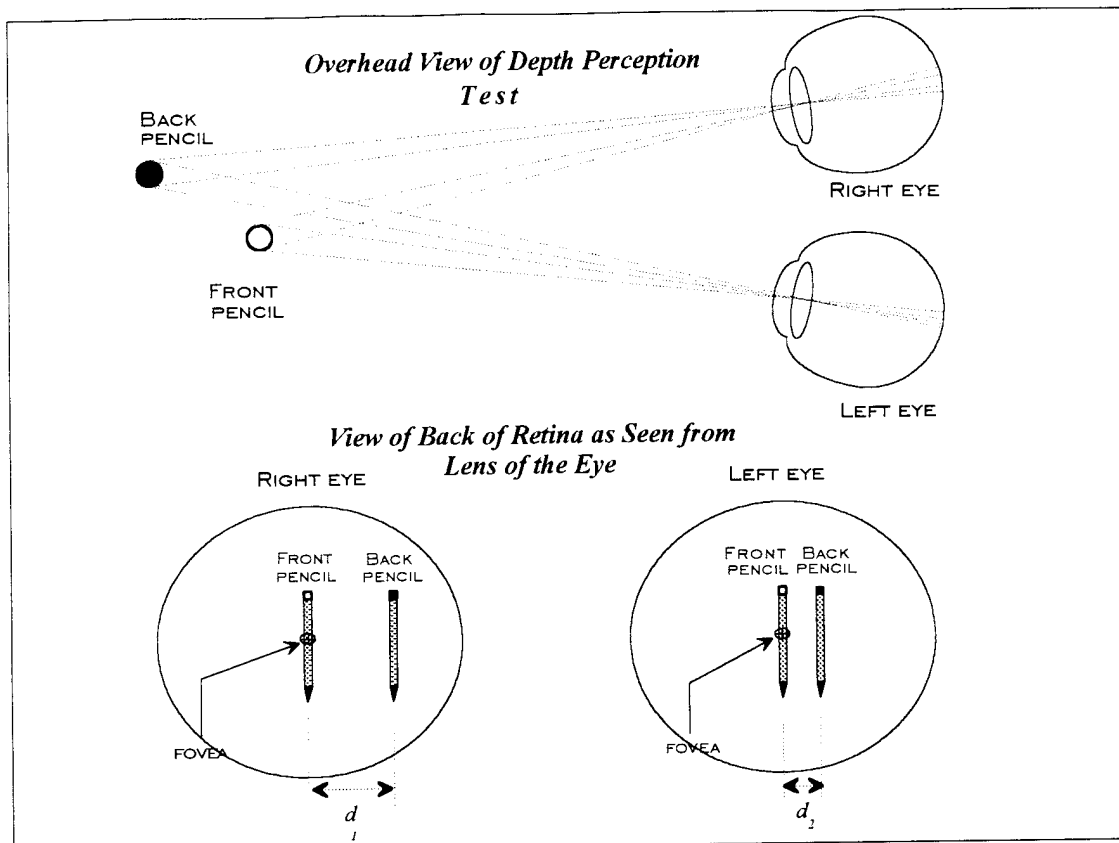

Figure 2-2. Simple Depth Perception Test.

This schematic demonstrates how the eye translates a difference in depth of two objects into a retinal disparity at the back of the retina. [After Ref. 8]

## 2. Flicker and Intermittent Stimulation

Another parameter which can have a significant influence on the ability to perceive binocular stereopsis is the *Critical Flicker Frequency* (CFF). The CFF is the threshold frequency for an intermittent light stimulus above which the eye can no longer perceive flicker [Ref. 11]. CFF is of particular importance in the development of alternating-field stereoscopic video devices because the presence of flicker in the video image can degrade the stereoptic effect.

One study on the variation of CFF with retinal illuminance shows that CFF actually increases with increasing illuminance [Ref. 11]. Figure 2-3 is a plot of CFF versus retinal illuminance for several different stimulus sizes. From this plot, it can be seen that operation of a video device below certain frequencies may subject the viewer to flicker at high enough levels of illumination and stimulus size.

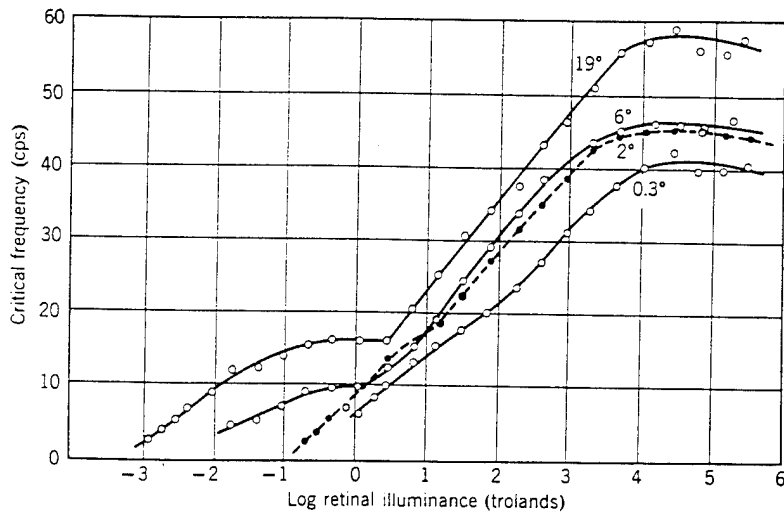

Figure 2-3. Graph of CFF Versus Illuminance. Influence of illuminance on CFF for several test field sizes (measured in angular degrees swept out by light source as measured from the eye). [Ref. 11]

Another study found a very slight elevation of CFF with in-phase stimulation of corresponding points in the two retinas. Alternatively, out-of-phase ( $180^\circ$ ) stimuli caused a decrease in CFF below that found for one eye alone [Ref. 11]. This is important in the design of stereoscopic devices since any alternating-field technique is essentially presenting  $180^\circ$  out-of-phase stimuli to the eyes. A lower CFF is desirable because it lowers the minimum rate at which a stereoscopic device must operate to avoid flicker.

Several studies have been performed to analyze CFF under various conditions; however, only two studies could be found on the impact of flicker on stereopsis. These studies indicate that binocular stereopsis may not occur during either in-phase or out-of-phase stimulation below the CFF. The studies recorded the electrical signals from single neural units in the visual system, and found that signals were not present at stimulation rates below the CFF [Ref. 11]. For binocular stereopsis to occur, 'binocular' neurons in the cortex must be stimulated. Further evidence that flicker does at least degrade stereopsis has been qualitatively shown during experimentation for this thesis.

### 3. Creating Stereopsis From a Two-dimensional TV Image

The ability to perceive a three-dimensional image in the mind through binocular stereopsis is truly a spectacular feat. It requires unconscious coordination and feedback between the muscles of the eyes, the retina, the cerebral cortex, and much of the rest of the brain. In order to better understand the hurdles that must be overcome in developing a stereoscopic system from a standard TV monitor, an overview of the stereopsis process is now presented. This overview ties together the several elements that make up our depth perception process to illuminate the importance of such factors as: physiology, flicker, experience, learning, and the presence of monocular depth cues.

For binocular stereopsis to occur, both eyes must first be directed at the same object. This is such a fundamental visual requirement that it occurs without conscious thought. In fact, it is not possible for humans to direct each eye independently [Ref. 12]. The next step in the stereopsis process is the collection and transmission of the image information to the brain. As discussed previously, this takes place mainly in the retina; receptors (*rods and cones*) in the retina relay individual "*pixels*" of information to the cerebral cortex. Other information is also sent: the muscles that control *accommodation* (pointing) of the eye and focusing of the lens also send feedback to the cerebral cortex. The cerebral cortex compares the two images from each eye and assesses the retinal disparity based on the displacement of the receptors receiving the image information. This does not end the process. The cortex must also take into account the degree of accommodation ("toeing-in" or "toeing-out") of the eyes, and the range of the object (partially determined by the feedback from the lens focusing muscles) to determine the specific depth to associate with a given retinal disparity between the images. Once the image is mapped in depth, the resulting three-dimensional image is checked for validity. The image is compared to similar objects in memory for consistency of size and shape; other known objects in the field-of-view are used to further establish image depth; and shading, motion parallax, and other monocular depth cues are employed to verify the overall stereo-image. Any one of these monocular depth cues can override the stereopsis effect and compel the mind to a different interpretation of the image.

This explanation may seem overwhelmingly detailed; yet, it conveys well the complexity of the process of binocular stereopsis. It also suggests some of the problems that may be encountered while attempting to reconstruct stereopsis from the video fields displayed on a TV monitor. These include: (1) flicker -- the eyes do not view the object simultaneously and so stereopsis is degraded or does not occur, (2) accommodation -- this valuable depth cue may be distorted or even completely absent when viewing a video monitor, and (3) focus -- the eyes are continuously focused at the range of the monitor, so this cue is non-existent.

## **B. THE IMPORTANCE OF BINOCULAR STEREOSCOPY**

The use of real-time video technology to provide visual feedback for remote operations is not a new concept. Teleoperations have pervaded all of the science disciplines, providing remote visual access to environments too harsh, too small, or too far away for actual human presence. Doctors can now use an endoscope with an attached CCD camera to perform major surgery with an incision no larger than an inch -- watching the entire procedure on a video monitor. Scientists have piloted a robot to the bottom of a volcano from a remote location using teleoperations.

With this growth of teleoperations has come a better understanding of the limitations of remote operations using only 2-D visual feedback. Many tasks are ideally suited for 2-D video since sufficient depth perception cues other than stereoscopic vision enable the brain to sufficiently determine relative depth, size, and object configuration so as to allow completion of the task in 2-D. Nevertheless, there are several tasks which are more difficult or even impossible without stereoscopic vision.

### **1. The Need for Binocular Vision**

It has been argued that binocular stereopsis is of some entertainment value, but is unnecessary for most remote teleoperations. After all, people with only one good eye can perform many tasks normally considered to require depth perception, such as driving a car, flying an airplane, and walking along unfamiliar terrain. In addition, many early studies found little experimental evidence of a performance advantage with 3-D displays.

More recent studies have shown that while binocular stereopsis (or 3-D vision) is not required for all tasks requiring visual feedback, it is absolutely essential for some. [Ref. 2,3]

As a simple example, our strong dependence on binocular depth perception cues is evident in tasks requiring ballistic pre-planned motions -- jumping from rock to rock in a boulder field, or running downhill on irregular terrain. These tasks are trivial with both eyes open, but are nearly impossible with only one eye. The simple task of planning the jump and landing spot cannot be performed in either case with only one eye because of the absence of monocular depth cues such as perspective or relative size. The requirement for absolute knowledge of the distance to the next rock, or of the steepness of the grade, necessitates binocular stereopsis. [Ref. 3]

Another even more fundamental need for binocular vision in humans is discussed in Reference 3. In the discussion presented in that paper, the author convincingly argues that man's binocular vision evolved because of the critical need for depth perception in a wilderness environment:

Another task (not commonly encountered by civilized people with one eye) is running through unfamiliar forest, where cues of familiar size and perspective are missing. All leaves may be the same shape, but their sizes are unpredictable, and thus the forest floor and the branches of undergrowth cannot be gauged in distance. Walking through the forest is not too difficult with only 2-D vision, but running requires look-ahead planning to see the best pathway through the trees, shrubs and rocks. It is often said that binocular cues are not needed because motion parallax provides the information. This is only partially true, since motion parallax is very limited at the origin of visual expansion (in the direction of travel, where it is most needed), and motion parallax ... does not provide all the information needed for pre-planning ballistic motor sequences such as running, jumping, turning left then right, and so on. [Ref. 3]

## **2. Tasks Which Require Stereoscopic Video**

The examples so far have argued for the need for *our* binocular vision (or that of an autonomous or remotely controlled robot) but what about simple teleoperations using a remote manipulator -- those missions for which the real-time, single-camera 3-D video system might be employed. A task that closely emulates the actual purpose for which many stereoscopic systems are designed is that of retrieving an object from the center of a

mass of tangled wires using a remote manipulator arm and video feedback. A mission to maneuver a remote manipulator through a tangle of wire and retrieve an object could be encountered in space repair work or undersea salvage. [Ref. 3]

It was found that this operation was not possible without 3-D vision [Ref. 2]. Subjects participating in the test were unable to navigate the remote manipulator through the maze of wire without becoming tangled when using the 2-D video mode. When the same task was attempted with binocular vision (using a two-camera system) the task became quite easy [Ref. 2]. Several other studies on the relative importance of stereoscopic video feedback have used the "tangled wire maze" set-up with similar results [Refs. 3, 13].

### **3. Tasks Which are Easier with Stereoscopic Video**

Other operations which commonly use video feedback for remote work have been found to be faster and prone to fewer errors when performed with some form of binocular stereopsis [Ref. 14]. One common example is the Peg-in-Hole (PiH) task commonly used for 3-D versus 2-D comparison studies. In this test, the subjects are required to remotely manipulate a grasping device (or robotic arm) to insert pegs in different shaped or sized holes using both monoscopic then stereoscopic video feedback. One such test of nine trained operators, each with proven depth perception and good visual acuity, indicated that, while 2-D visual feedback was adequate to complete the task, the stereoscopic video improved both the time to complete the task and the error rate. [Ref. 14]

Studies of several tasks in which 2-D teleoperations are currently used show varying degrees of improvement when stereoscopic techniques are employed. In some areas, sufficient depth perception cues other than binocular stereopsis cues may provide sufficient depth indication, obviating the need for 3-D vision. Examples of this type of application include: simple information gathering, remote manipulations in familiar areas, and operations for which known depth cues, such as relative size, shadowing, or perspective are present. An overview of several tests comparing 3-D versus 2-D in many teleoperations fields seems to indicate that 3-D information is most useful in operations performed in unfamiliar work areas, where other depth cues are insufficient to provide the necessary feedback. [Refs. 3, 14, 15]

## C. APPLICATIONS OF A REAL-TIME, SINGLE-CAMERA, STEREOSCOPIC VIDEO DEVICE

This section presents several applications of a real-time, single-camera Stereoscopic Video Device (SVD) -- primarily to establish the efficacy of SVD's in fields which require near-field, precise remote teleoperations.

### 1. Space Applications

Space missions, by the very nature of the working environment, present a demanding and rather unique set of challenges to the performance of precise remote operations. Spacesuits and life-support connections required for repair operations impose limits on the degree of accuracy with which an astronaut can be expected to perform a task on sight. This problem is compounded by the complexities that arise when performing even the simplest tasks in zero gravity. One solution is the integration of remote teleoperations for precise remote tasks. NASA has used remote monoscopic, real-time video feedback effectively for several years, with perhaps the best known example being the space shuttle cargo bay remote control arm. With the establishment of Space Station Freedom, NASA will no doubt be forced to increase this reliance on remote teleoperations, possibly even controlling tasks from Mission Control.

The increased demands on video for control and information feedback will inevitably strain the bounds of conventional Monoscopic Video (MV) technology. As previously discussed, some tasks simply cannot be effectively performed using monoscopic video, while others are much more difficult and time-consuming than with Stereoscopic Video (SV). Why then has SV not been thoroughly integrated into space teleoperations? The answer is twofold: (1) the increased complexity and additional space and weight that accompanies current SV systems is quite often not sufficiently balanced by the expected improvement in time and precision; after all, not all tasks require 3-D vision, and (2) current SV systems require two camera detectors (such as CCD's), effectively doubling the bandwidth of the signal that must be transmitted and received. This can be a significant obstacle to SV use in space, since increasing the signal bandwidth, especially between the

spacecraft and mission control, requires more power and may also necessitate upgrading existing communications equipment.

The solution to the problem of integrating SV into current MV teleoperations systems is compatibility and compactness. The single-camera SVD provides both. As discussed earlier, it is compatible with standard NTSC video channels now used in space and can be transmitted on a single channel. In addition, it requires no new cameras or monitors. Also, since it is an in-line optical package, it can be miniaturized quite well for close-up work in areas in which normal access is limited. Finally, it can be used in both the SV and MV mode without any change in the camera or lens configuration.

## **2. Terrestrial Applications**

A single-camera SVD is ideally suited to near-field, precision operations and inspections in areas that are normally inaccessible for hands-on work. Although several tasks currently fit this description, not all would benefit from SV; an SV system must also be cost effective to install and operate, and provide a measurable and significant performance improvement over existing MV devices. Examples of applications that meet these criteria include: surgical optical devices such as endoscopes [Refs. 16, 17], underwater repairs, research, and exploration that employ remote vehicles and robotics [Ref. 3], and remote engineering, environmental clean-up, and scientific teleoperations [Refs. 18, 19, 20]. The common denominator in each of these operations is the *absence* of relative depth cues which would normally de-emphasize the dependence on SV.

The endoscope is an excellent example of MV teleoperations in an area with few strong depth cues -- the human body. The doctor using an MV endoscope must operate by watching a 2-D video of the area in which he is working. Because of the high magnification of the image and the relatively small focal length and depth of field of the instrument, very few significant depth cues are available. As a result, most doctor's experience a steep learning curve in controlling the surgical instruments with MV. Even those with experience on the device must rely on watching the effect of the surgical instrument on the tissue with which it makes contact to establish the position of the instrument.

An in-line optical device such as the one proposed in this thesis can be packaged to attach to a standard endoscope (6-12 mm). In fact, one of the design criteria for the development of the prototype SVD is the construction of a device small enough to fit on the end of an endoscope.

## **D. A SURVEY OF STEREOSCOPIC VIDEO TECHNOLOGY**

### **1. Stereoscopy in Entertainment**

By the end of the 18<sup>th</sup> century, advances in the study of physiological optics and the proliferation of relatively inexpensive optical equipment had spawned an interest in stereoscopic devices. Charles Wheatstone developed the first stereoscope in 1834. This device used two mirrors mounted at a 45° angle to each eye to present separate but similar views of the same picture to either eye. Although this device worked quite well, it was not an overnight success; the "pictures" that Wheatstone used were merely hand-drawn geometric shapes -- photography as we know it had not yet been invented. [Refs. 10, 21]

For the general public to become excited about a stereoscopic video device, the image produced had to be somewhat more real and exciting; this problem was soon solved by the invention of the photograph. Soon after that, David Brewster invented a stereoscope using two plano-convex lenses to view stereoscopically-related photographs. His stereoscope is shown in Figure 2-4. This device was displayed at the London Exposition in 1851, and within 3 months, over 250,000 were sold. [Ref. 21]

The final ingredient necessary to bring the science of stereoscopy to the general public was the invention of the motion picture. In 1893, Edison and Lumiere simultaneously developed a camera with intermittent movements that used an endless band of celluloid with a light-sensitive emulsion. A combination of Lumiere's frame rate (16 fps) and Edison's film size (35 mm) soon became the industry standard. Lumiere went on to develop the first stereoscopic motion picture, using a blue dye for the right image and an orange dye for the left image. The audience viewed the film with blue and orange glasses, so that the blue side could only see the orange image, and the orange side only the blue image. [Ref. 21]

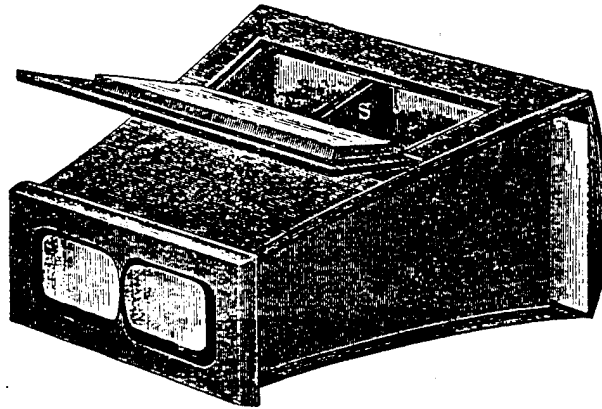

Figure 2-4. Charles Brewster's Stereoscope.

The stereogram is inserted in a slit in the side (shown fully inserted). The stereogram, consisting of two stereoscopically-related images, is situated inside the focal plane of the eyepiece lenses so that the two images are superimposed at the common focal plane to produce a 3-D image. [Ref. 10]

## 2. Stereoscopy in War

One of the first applications of stereoscopy for war was the development of a stereoscopic aerial camera used for reconnaissance during WWII. General George W. Goddard headed up a special division in the Air Force created to study how stereo-aerial photographs could be used to provide strategic information. Goddard's division designed a special stereo-camera called "The Sonne Strip Camera" -- a low altitude stereo camera that used standard nine-inch aerial film. Although the stereo-camera was used only sparingly during WWII, it was brought out of mothballs for use in 1962. The Cubans had established nuclear missile bases, and President Kennedy wanted undeniable proof that the missiles were ready to be launched. So, he had the Sonne Strip camera mounted on the wing of a high speed jet. The jet made a low pass over Cuba at maximum speed, and Kennedy had his proof. The Sonne Strip camera and some of these photographs can now be seen at the Air Force Museum in Dayton, Ohio. [Ref. 21]

## 3. 3-D Video Technology

3-D video technology refers to the use of a camera or system of cameras to make a video image which, when viewed with special glasses or a special video monitor, produce

a 3-D effect. Two general categories of 3-D video technology are currently in use: (1) *stereoscopic*, those requiring use of special glasses or viewing aids, and (2) *autostereoscopic*, those which require no glasses -- many of these systems produce a pseudo-stereoscopic effect but do not employ binocular stereopsis.

*a. Stereoscopic Video Systems*

Most 3-D television systems use two cameras and a system of hardware or software to time-multiplex the fields at either the standard NTSC field rate, or twice that rate. The cameras are oriented such that the angular disparity between the views is comparable to that produced by the offset of the eyes. A 3-D image is realized when the subject views the monitor through shuttered glasses, oppositely polarized lenses, or some other alternating-field technology. Of these systems, Stereographics® has one of the most innovative and refined designs. [Ref. 5]

Figure 2-5 shows the layout of the Stereographics® 3-D video system. The system consists of two standard cameras fixed such that their optical centerlines are 2-1/2 inches apart. these cameras feed the video signals to a controller at a field rate of 60 fields per second (fps) each. The controller stores the two signals and alternately displays the fields on the monitor at a rate of 120 fps. The monitor is viewed with Stereographics® CrystalEyes LCD glasses, which are synchronized to the field rate of the monitor using a CrystalEyes infrared (IR) emitter [Ref. 5].

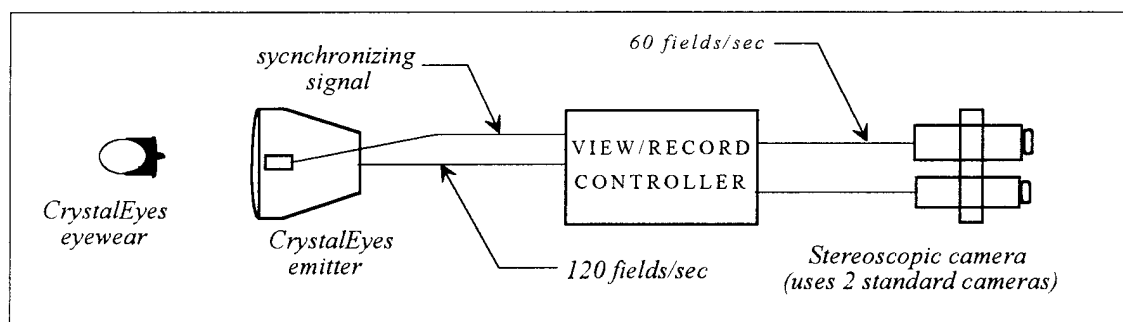

Figure 2-5. Stereographics® 3-D Video System. [After Ref. 5]

This system presents the most viable product presently on the market for real-time stereotelevision. As with any two camera system, this design does have some problems:

two channels are required for transmission and reception of the signal, and the system requires a special controller unit and a high speed (120 fps) video monitor.

Several other designs of stereoscopic video systems using mechanical shutters, color filters, polarizers, and lens-prism devices have been developed. Figure 2-6 shows a single channel, spatial multiplexing system which uses a standard video monitor with a specially polarized stereo-screen. The images are spatially separated by the lens system in front of the camera. The video monitor displays both images side-by-side or over-and-under, and the stereo-screen polarizes the light from the two images in opposite directions. The glasses include oppositely polarized lenses for each eye such that each eye sees a separate view. Problems with this system include: loss of image resolution, a decrease by 1/2 in image size, and possible visual distortion and head viewer orientation limitations. [Ref. 6]

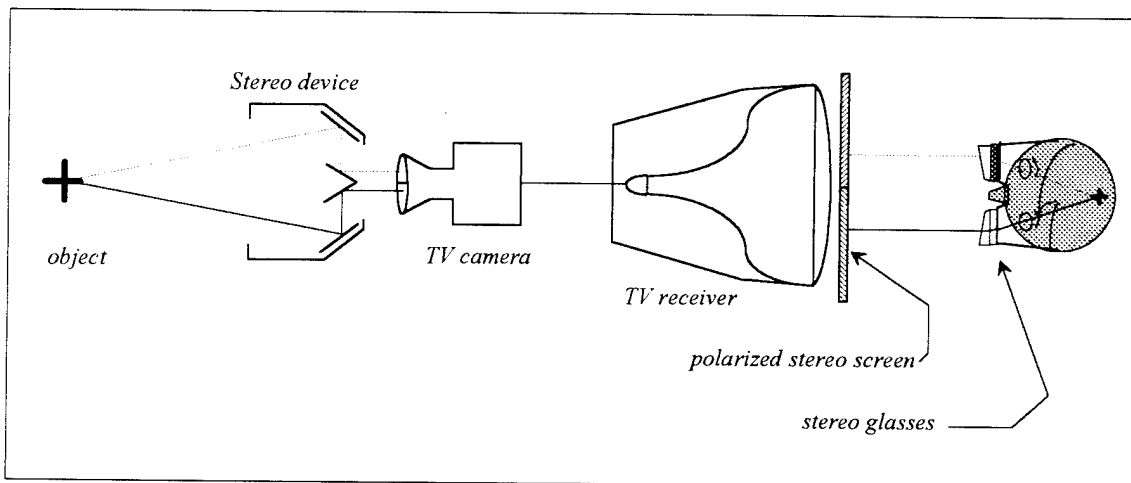

Figure 2-6. Single-channel, Spatial Multiplexing System. [After Ref. 6]

Other devices use mechanical shutters or specific color filters (usually red and cyan) at both the camera lens and the monitor, as displayed in Figure 2-7. These devices must also be used with special glasses to perceive stereopsis.

The systems described above are only a representative sample of the types of systems that have been developed to produce binocular stereopsis. While each uses somewhat different methods to obtain separate, stereoscopically related left and right images, all of these devices use true binocular stereopsis to form the 3-D image.

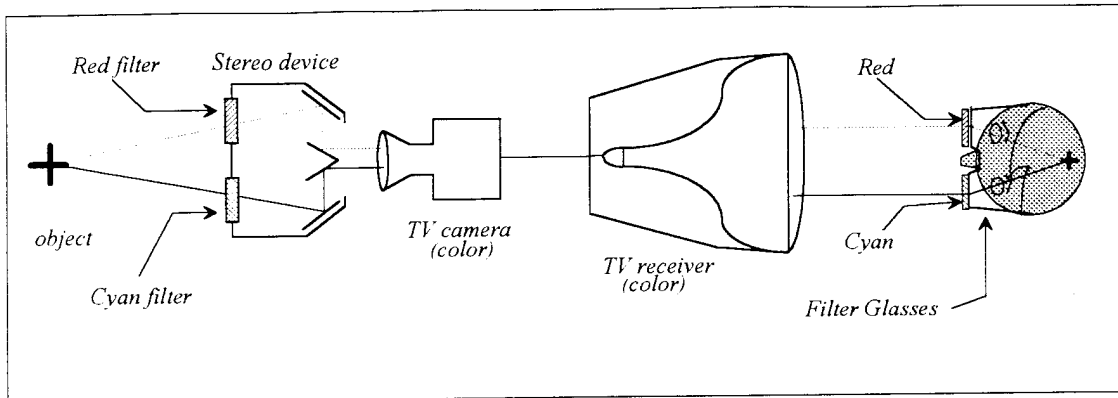

Figure 2-7. Single-camera, Color-multiplexing Scheme with Colored Glasses.  
[After Ref. 6]

**b. Autostereoscopic Video Systems**

Autostereoscopic systems have been developed for both individual use and group viewing. Figure 2-8 shows both of these systems. In the individual system, two cameras are used to present related images to the eyes through a special screen. The viewer must maintain his head at the optimum viewing position to detect the stereoscopic effect. The group system uses a lenticular screen assembly to provide several possible viewer positions. The primary disadvantage of these systems is quite obvious; the viewer must maintain his head within fairly tight bounds. [Ref. 6]

The VISIDEP™ (visual image depth enhancement by parallax induction) alternating-frame technology is a more recent technology which produces limited depth enhancement by shuttering left and right views of an object on the monitor at a rather slow

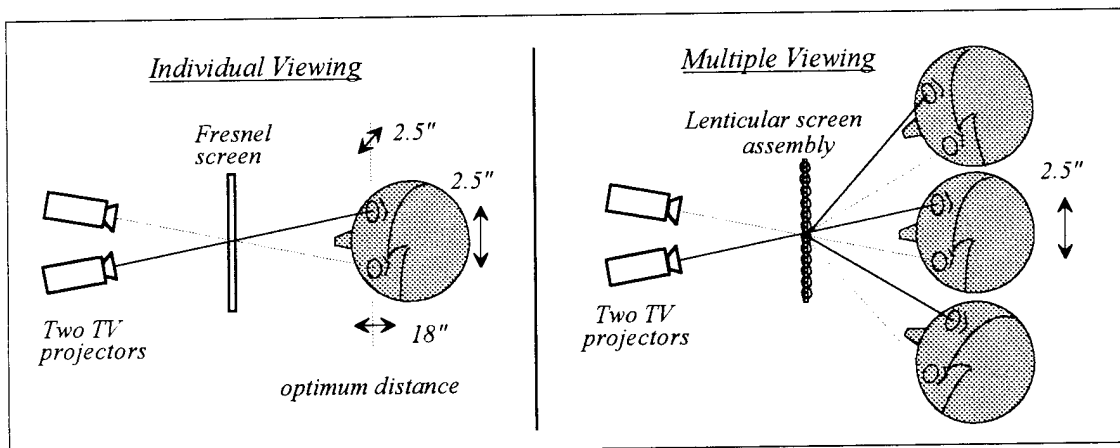

Figure 2-8. Autostereoscopic Stereo-pair Systems. [After Ref. 6]

rate (usually about 10 Hz). The parallax between the two views permits a judgment of relative depth [Ref. 16]. Because of the slow speed at which the alternate views are presented in this method, both eyes see each view -- thus no real binocular stereopsis occurs. Also, the slow shutter rate can cause dizziness and headaches if viewed for prolonged periods.

### III. DESIGN OF A 3-D VIDEO IMAGING DEVICE

This chapter documents the development of a real-time, single-camera, stereoscopic video imaging device. First, the theory behind the concept of a single-camera stereoscopic video device (SVD) is described in detail. Next, the development of the initial prototypes is reviewed, including a discussion of the theory of operation of each component and a description of the modifications required to attain the final SVD design. Lastly, the design for a working SVD, comprised of a lens system, an LCD shutter, and a synchronizing circuit, is presented.

#### A. ALTERNATING-FIELD 3-D VIDEO THEORY

Several SVD designs make use of the alternating-field concept together with some type of shuttering glasses to produce a stereoscopic effect. These SVD's have many features in common: two stereoscopically-related views of an object must be taken, either simultaneously or alternately at a fast rate; the views are alternately displayed on a video monitor at the field rate of the monitor; and, finally, the monitor must be viewed with some shuttering device such that only the left eye sees the left-hand image and only the right eye the right-hand image of the object. How our SVD will achieve these steps is discussed in this section.

##### 1. Lens Theory

Recall that a simple lens focuses parallel rays at its focal point, as in Figure 3-1. Parallel rays incident upon a lens from a certain angle  $\theta$ , as measured from the centerline of the lens, are focused at a height  $y$  above the centerline at the focal plane of the lens. A detailed discussion of geometric optics and ray tracing can be found in Reference 22.

An object reflects light such that rays emanate in all directions from every point on the object. One method of accounting for these rays is to group them according to the angle at which they leave the object. Those rays leaving the object at the same angle are parallel. Rays which leave the object at the same angle with respect to the centerline of

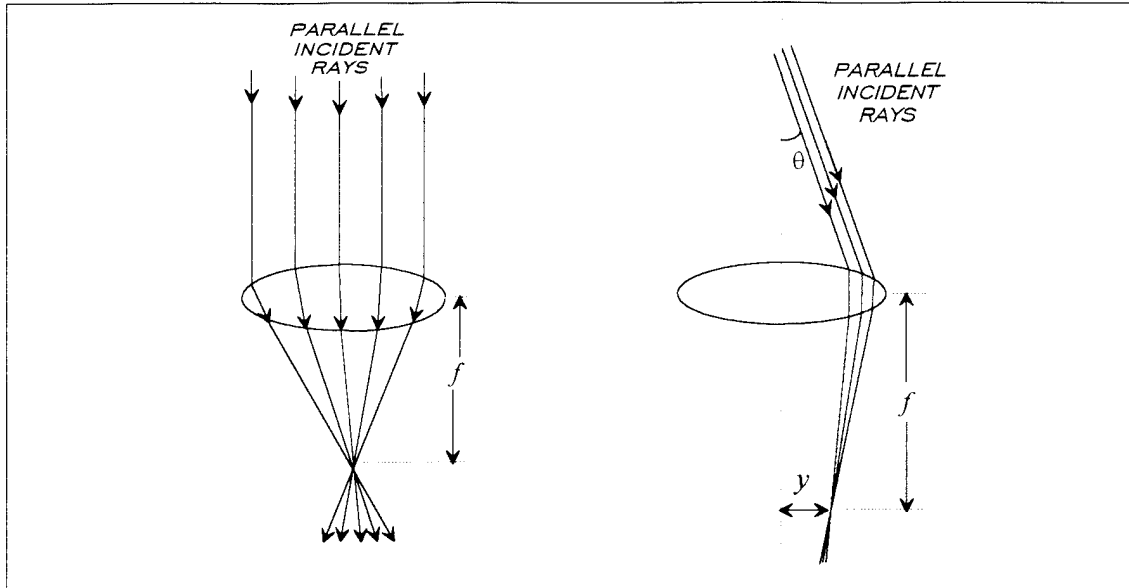

Figure 3-1. Simple Lens Analysis Using Ray Tracing.

the lens system will be focused to the same point on the focal plane. Rays which leave the object at a different angle will be focused at a different point on that same focal plane. Parallel rays emanating from the object to the left of the centerline are focused on the left side of the focal plane of the lens, and those emanating from the right are focused on the right side of the focal plane. This concept can be used to spatially separate different angular views of the object, and the separate views can then be blocked to allow only one view at a time to the camera detector.

## 2. Lens System Description

Figure 3-2 is a top-view depiction of a general alternating-field stereoscopic video device. Parallel rays from the object are focused by the objective lens at the focal plane of the lens. To get only one view of the object, we must *block* all those rays which emanate from the object at an angle to one side of the centerline of the lens system (e.g., those rays which make up the left-hand view of the object) and we must *pass* those rays which emanate from the object to the other side of the centerline (e.g., those rays which make up the right-hand view of the object). To do this, a shutter is used to alternately block the rays from the left-hand and then the right-hand side of the image. This shutter must be properly synchronized with the camera, the monitor, and the stereoglasses.

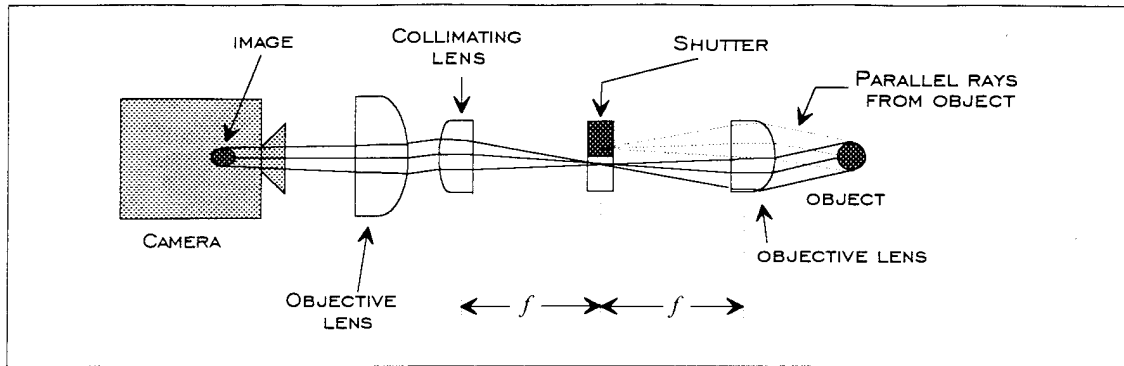

Figure 3-2. Overhead View of a General Single-camera Alternating-field Device.

The rays from a single view are re-collimated by the second lens in order to re-form the image. Then, the image is focused by the camera's objective lens on the camera detector. The detector collects the image and transmits it to the monitor for display as one video field.

### 3. Producing a Stereoscopic Video Image

A standard NTSC TV monitor displays one frame every 33.33 msec (a frame rate of 30 Hz). Normally, a video image, or frame, consists of two interlaced video fields. For our purposes, we will use a single non-interlaced field as our image. The two stereoscopically-related views are alternated on the monitor at the field rate of 60 Hz. In order for the viewer to perceive a separate view of the object with each eye, he must wear stereoglasses. These glasses use an LCD shutter in each lens to pass light to only one eye at a time at a rate set by a special synchronization circuit.

### 4. Summary of Alternating-field Video Stereoscopy

An objective lens is used to focus rays from the object to the focal plane of the lens. Here the rays are filtered by a shutter such that only one view of the object is passed at a time. The light rays that are passed by the shutter are collimated to re-form the image, then focused on the camera detector by a second set of lenses. The image incident upon the detector is transmitted to the video monitor and displayed as one video field (for 1/60 second). Finally, the LCD stereoglasses, operating in synchronization with the shutter, camera detector, and monitor, allow only one eye to see the video image, the left eye seeing only the left view and the right eye only the right view. If this process is performed

fast enough, at a frequency above the critical flicker frequency (CFF) defined in Chapter II, the brain will be able to fuse the disparate images from each eye into a three-dimensional image of the object.

## **B. ELECTRO-MECHANICALLY SHUTTERED STEREOSCOPIC SYSTEMS**

Three prototypes were employed during the development and testing of the single-camera SVD. The first system consisted of a chopper wheel for both the initial shuttering of the two views of the image at the focal plane and for viewing the video image on the monitor. This device was designed and built at the Naval Postgraduate School by Professors Robert Keolian and David Cleary of the Physics Department. In the second system we used stereoglasses instead of a chopper wheel to view the video monitor. These two systems will be discussed in this section. The final design implemented a zoned LCD shutter at the focal plane of the lens device. This design will be discussed in the next section.

### **1. Chopper Wheel Shuttering System**

A schematic of the first shuttering system is shown in Figure 3-3. The separate views of the object are shuttered at the focal plane by a chopper wheel driven by a DC motor. The chopper wheel is a transparent plastic disk with opaque areas configured to intermittently block the light as the wheel rotates, as depicted in Figure 3-3. A similar chopper wheel located between the monitor and the viewer shutters the view to each eye.

Each chopper wheel DC motor is synchronized to the video signal using a lock-in amplifier. A sketch of this circuit is shown in Figure 3-4. The reference signal to the lock-in amplifier is a square wave synchronized to the video signal. The feedback signal (or comparison signal) to the lock-in amplifier is the output of a photodetector which senses motor frequency and phase from a white and black pattern connected to the motor shaft. The output of the lock-in amplifier is first amplified and then offset with a DC gain to raise the speed of the motor to that required for synchronization.

The system was constructed on an optical bench and tested. All participants reported a distinct binocular stereopsis effect when viewing the test object. This was considered a successful test; however, several features of this device are unsuitable for the

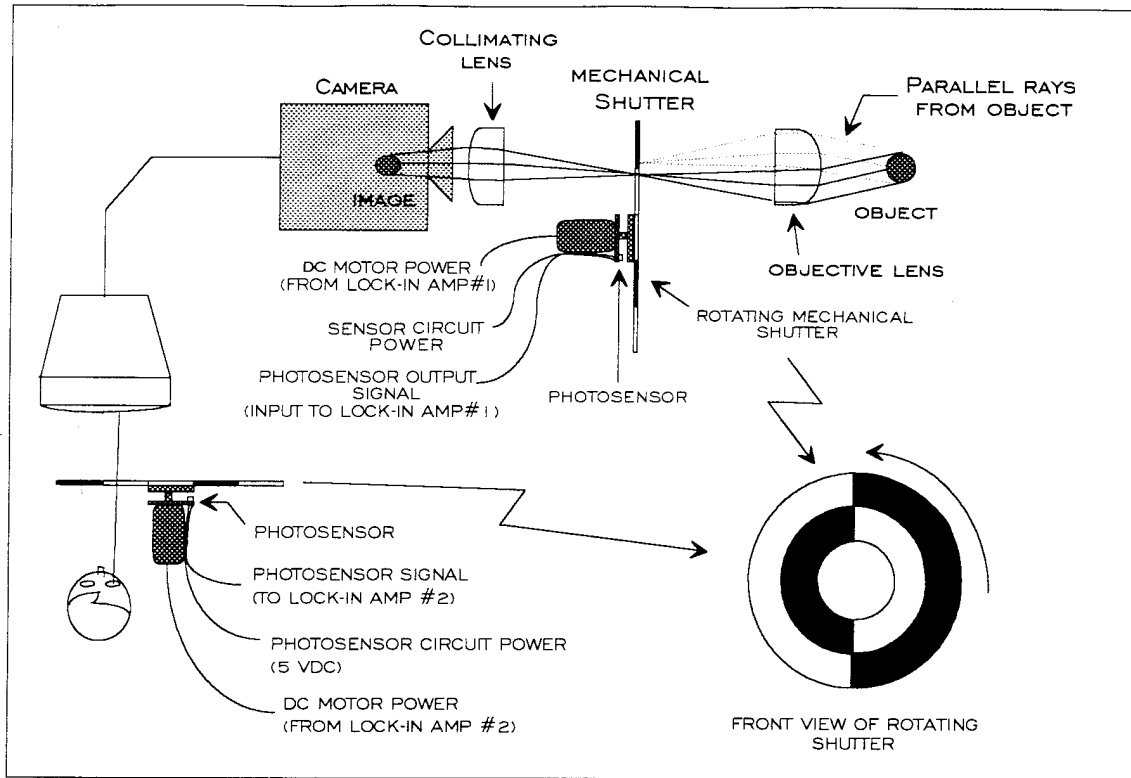

Figure 3-3. Top View Schematic of the Chopper Wheel Shuttering System. Each chopper was a transparent plastic wheel with opaque (black) areas zoned to intermittently block the light as the wheel rotated. An individual DC motor driven by a synchronizing circuit turned each shutter.

intended applications of the SVD, particularly those requiring miniaturization. These unsuitable features include the following: (1) both chopper wheels are too large for the SVD's intended applications, and the video monitor chopper wheel cannot be miniaturized without a deterioration of the viewing conditions, (2) the video monitor chopper wheel spinning near the observer's face is objectionable and severely limited the viewer's mobility, and (3) the power required by the DC motors is too high for efficient use in a smaller, more portable system. Despite these problems, the test did provide a proof-of-concept for a single-camera SVD.

## 2. Chopper Wheel Shutter with Stereoglasses

The next step towards the development of a practical system was to replace the chopper wheel for the monitor with LCD stereoglasses. An example of commercially

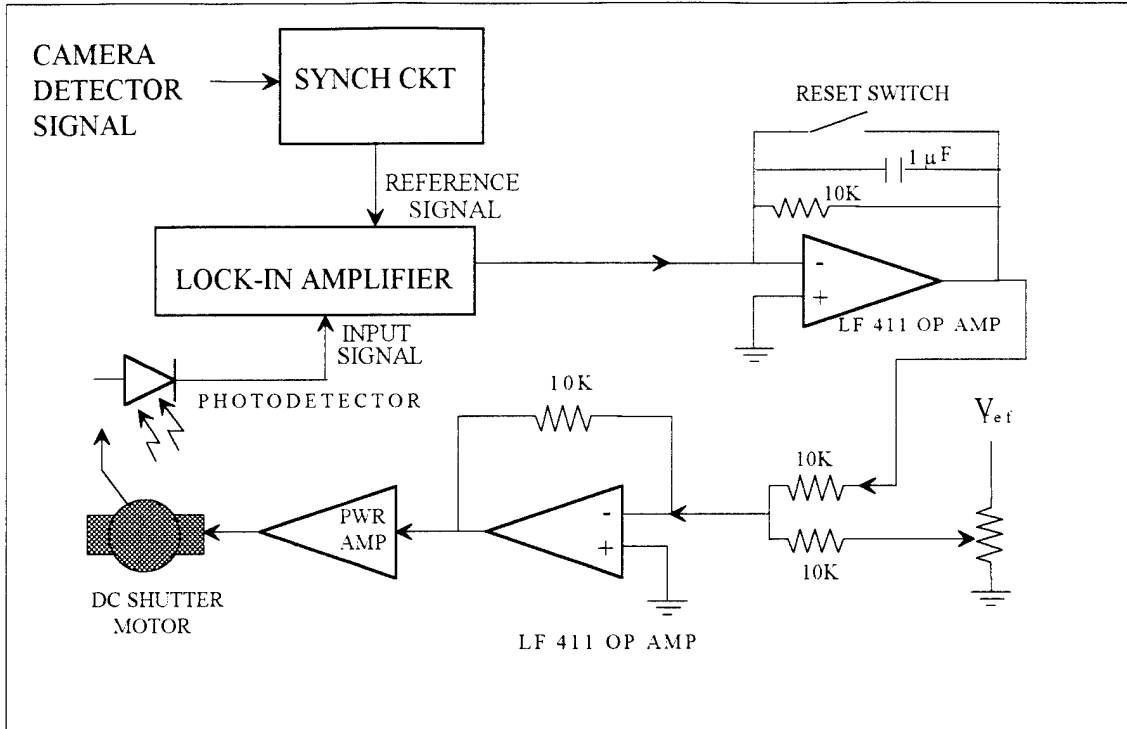

Figure 3-4. Schematic of DC Shutter Motor Control Circuit.

available stereoglasses for this application is the *CRYSTALEYES* model developed by Stereographics®. The stereoglasses used for this thesis shutter the light to each eye such that only one eye is receiving an image from the video screen at any one time. The stereoglasses are synchronized to the video signal by an IR emitter which transmits a timing signal to a receiver on the glasses.

The chopper wheel shutter system with stereoglasses is shown in Figure 3-5. The chopper wheel in this lens system is identical to that discussed in the previous section, and the control circuit for this chopper motor is similar to that shown in Figure 3-4. A detailed description of the glasses, including the modifications necessary to work in our system, is discussed in more detail below.

This system as shown in Figure 3-5 was tested on an optical rail, and binocular stereopsis was again perceived by several viewers. The stereoglasses were convenient to wear and provided the viewer with more mobility than was possible with the stationary chopper wheel shutter. Nevertheless, the use of a chopper wheel shutter in the lens assembly still did not meet all of the design objectives for the prototype. In particular, the

chopper wheel draws too much power and is not easily scaled down to the sizes necessary for the intended applications of the SVD. A further refinement to the SVD design was needed to address these shortcomings.

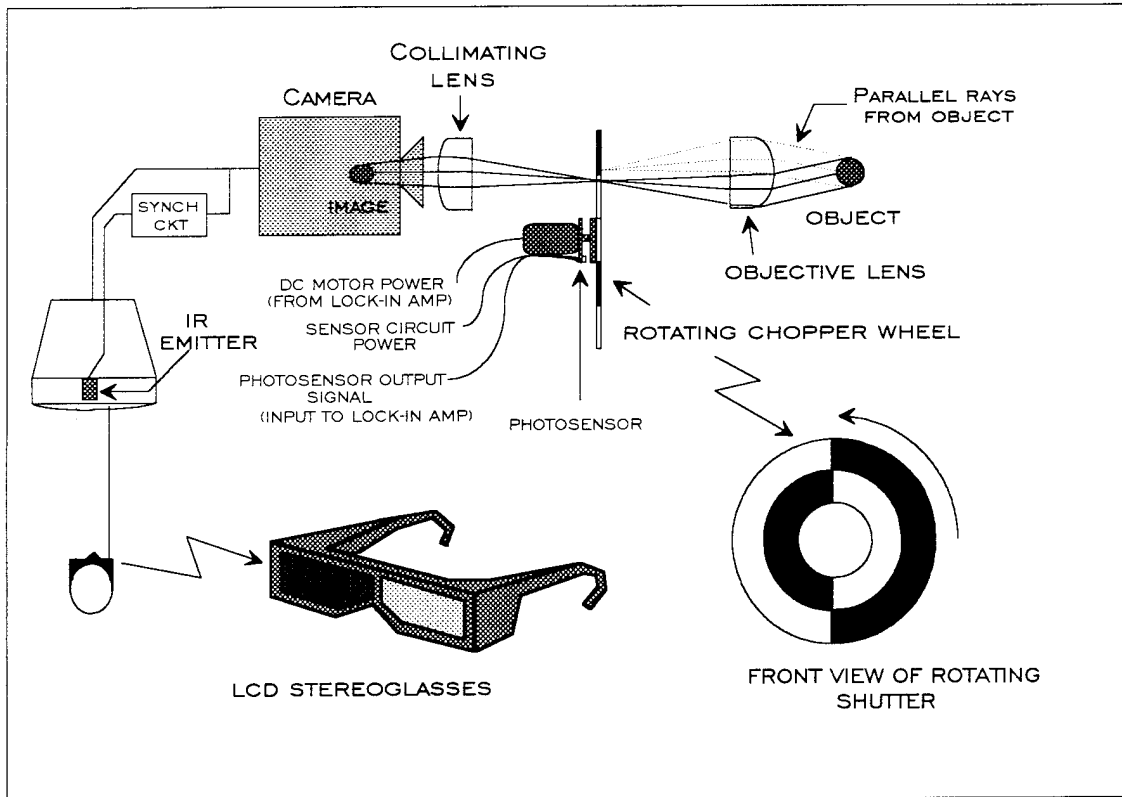

Figure 3-5. Top View of Chopper Wheel Shutter Device Used with Stereoglasses.

### C. LCD SHUTTERING SYSTEM WITH STEREOGLASSES

The final single-camera SVD design uses an LCD shutter in place of the chopper wheel in the lens assembly. Figure 3-6 is a schematic of the final SVD. The major components of the design are the lens assembly, the LCD shutter assembly, the stereoglasses, and the synchronizing circuit. The device is designed to work with a standard camera and video monitor operating at the NTSC field rate. The design is compatible with a commercial endoscope to provide a realistic application with which to test the device. This section describes the design of each component of the final system in detail.

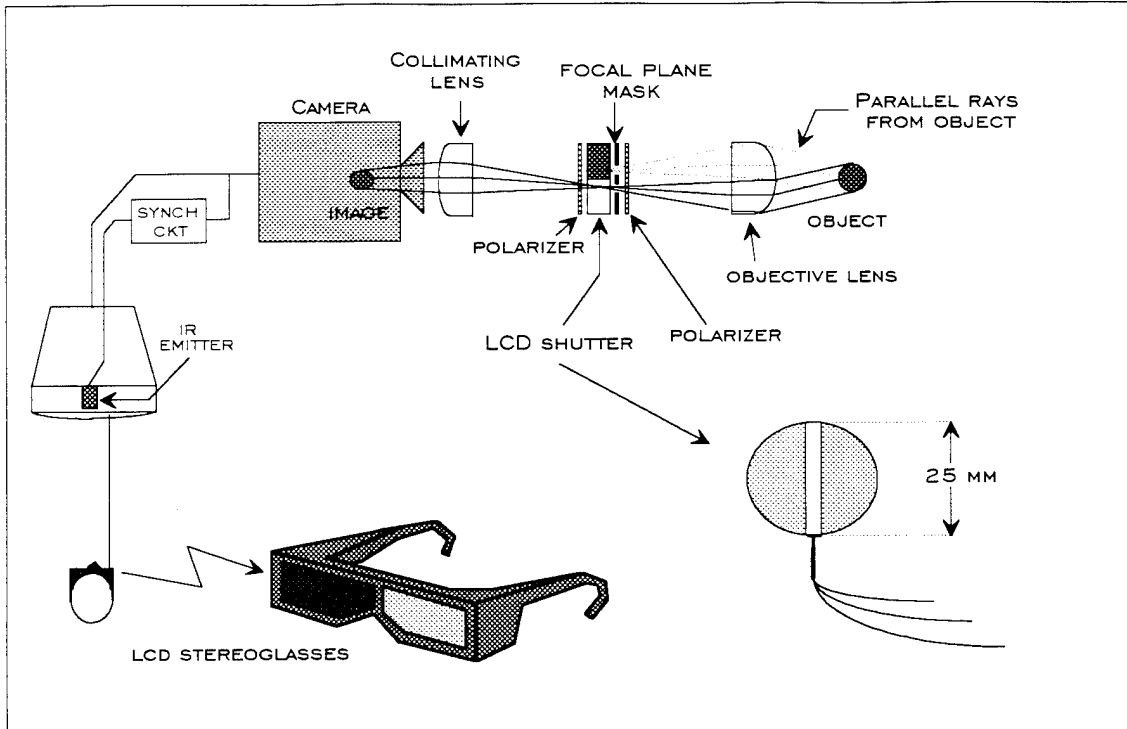

Figure 3-6. Schematic of the Single-camera, Stereoscopic Video Device.

### 1. Lens Assembly

The lens system was designed for close-up, narrow depth-of-field operations. The objective lens and the collimating lens are achromatic, 25 mm diameter lenses with an effective focal length of 50 mm. A schematic of the lens arrangement is shown in Figure 3-6. Achromatic lenses were chosen both to allow compatibility with color cameras and to provide the highest precision focus for both black-and-white and color cameras over the entire range of the visible light spectrum. Other lens combinations are available for situations requiring a larger depth-of-field or a reduced viewing angle.

### 2. LCD Shutter Assembly

Because of the fast response, controllability, and compactness of liquid-crystal shutters, it was determined that LCD technology offered the best alternative to a chopper wheel shutter. LCD's have been developed that switch within microseconds, and the control circuit for an LCD typically consists of only a single voltage signal and a ground line. Furthermore, LCD's can be miniaturized to the sizes required for this project.

### *a. LCD Shutter Theory*

A general design for an LCD is shown in Figure 3-7. A plane polarizer placed before the liquid-crystal (LC) polarizes the incident light in one direction. The LC layer rotates the plane of polarization of the light by  $90^\circ$  when the LCD electric field is OFF (deenergized). When the LCD is energized, the liquid crystal layer does not rotate the plane of polarization of the light. By placing a second plane polarizer after the LC, with its polarization axis oriented at a right angle with respect to the first polarizer, a light shutter is formed. The second polarizer will only pass the light that has been rotated by  $90^\circ$  with respect to the initial direction of polarization. In other words, it will only pass light when the LCD is deenergized. By applying and removing the electric field on the crystal, the polarizer-LC-polarizer system acts as a light switch or shutter. [Ref. 23, 24]

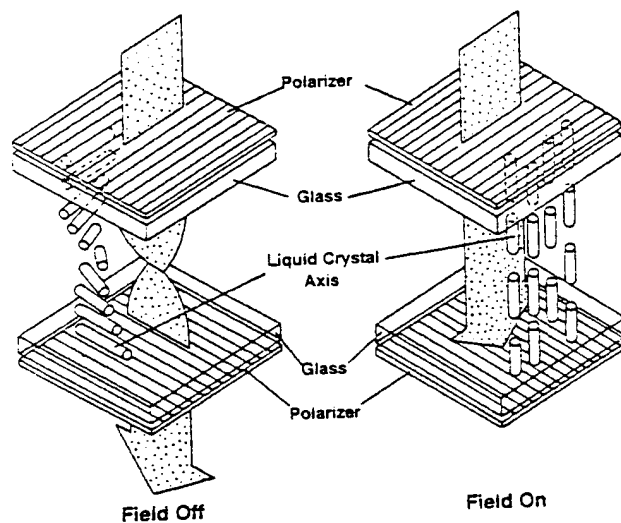

Figure 3-7. A Sketch of a Light-twisting LCD Shutter.

Thread-like liquid-crystal molecules are arranged so as to rotate the polarization of light. Non-energized pixels enable the light to pass a second polarizer (left). When a voltage is applied, the twist is disrupted, and the light is blocked (right). [After Refs. 23, 24]

### *b. LCD Shutter Design*

The LCD shutter design for use in the single-camera 3-D device consists of a circular LCD shutter with two independently controlled active LCD areas and a non-active center section. The LCD shutters were designed with semi-circular active zones to

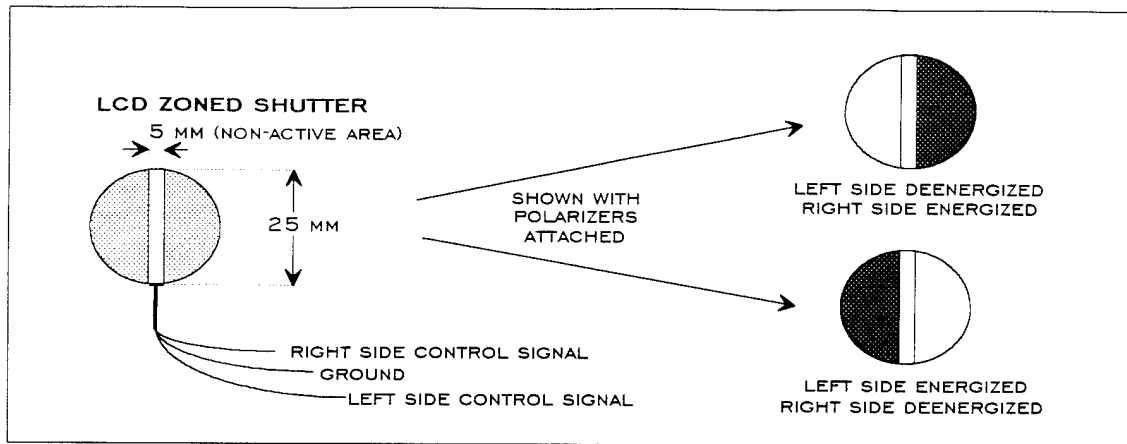

Figure 3-8. Schematic of the LCD Shutter, Showing Both States of the Device.

allow the maximum light from each view through to the detector. The center section of the shutter contains liquid-crystal material but is not controllable, since these rays are essentially at a zero angle of incidence and are common to both views.

Figure 3-8 shows the design of the LCD shutter. A photograph of the LCD shutter device, including the polarizers, focal plane mask, and casing, is shown in Figure 3-9. Light passes through a plane polarizer, then through a focal plane mask (discussed in detail in the next section), into the LCD shutter, and through a second polarizer. The LCD shutter and the mask are located at the focal plane of the objective lens. Also, the collimating lens is situated at exactly one focal length behind the shutter.

To minimize the flickering of the image on the video screen, it is desirable to use a shutter in the lens system which switches within about 100 microseconds. This minimizes the fraction of the image duty cycle taken up in switching the LCD shutter. To meet this switching time, a ferroelectric LCD shutter produced by Boulder Nonlinear Devices was used. The LCD shutter is reported to have a switching time as fast as one microsecond, a transmission ratio of nearly 1000. The transmission ratio is the optical power transmitted when LCD is ON (deenergized) relative to power transmitted when LCD is OFF (energized). The device also exhibits a good transmission characteristic over most of the visible light region. Figure 3-10 is a graph of the transmission characteristic of the LCD shutter over the visible light band. The drop in transmission at the upper and lower ends of the visible spectrum represent light loss in the system.

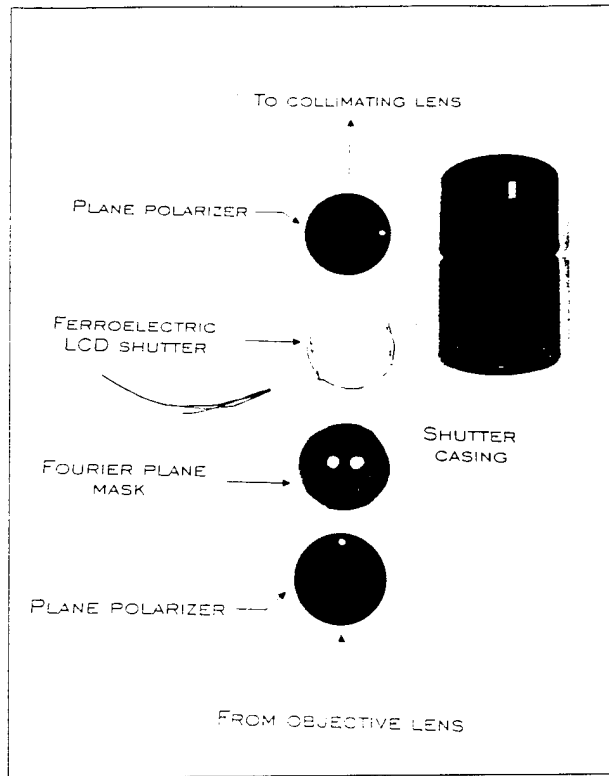

Figure 3-9. Photograph of the LCD Shutter Device and Casing.

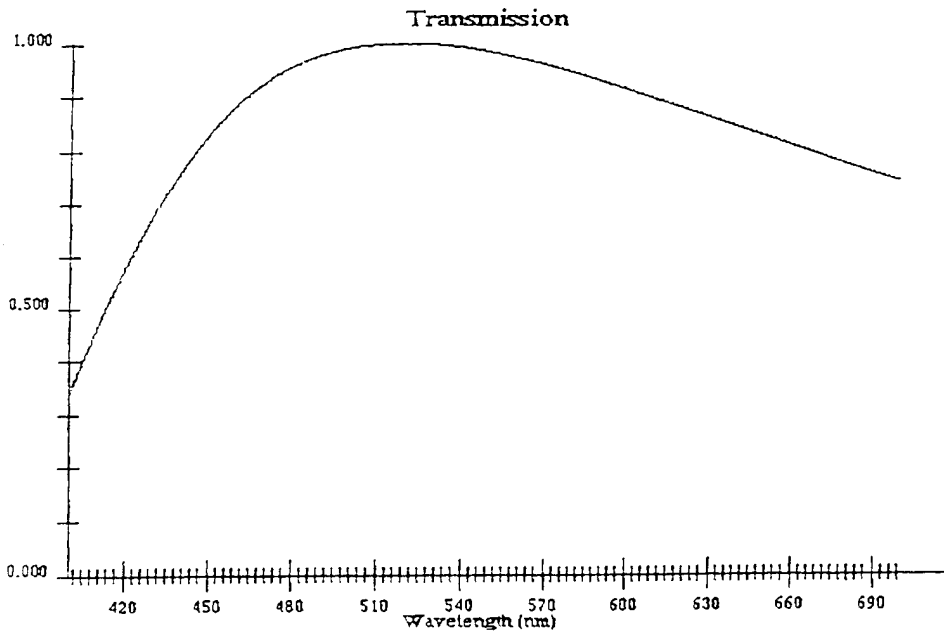

Figure 3-10. Computer Simulation of the Transmission Versus Wavelength Characteristic for the Zoned LCD Shutter Used in the Stereoscopic Video Device.

### *c. Focal Plane Mask*

An SVD using the LCD shutter described above was fabricated and tested. The resulting video image was blurry, causing a degradation of the stereopsis effect. The cause of the blurring was determined to be the wide range of views of the object presented to each eye. In normal binocular stereopsis, each eye perceives only a small range of views of the object, as determined by the solid angle bisected by the pupil of the eye. However, in our original device design, the camera received a range of views only limited by the size and characteristics of the lens and shutter system. The presentation to each eye of this wide range of views of the object made the image appear blurry, thus inhibiting the stereopsis process.

The solution was to design a mask which would be placed at the focal plane of the lens. The position of the mask with respect to the shutter mechanism and the shape of the mask can be seen in Figures 3-6 and 3-9. This design was chosen to approximate the solid angles intercepted by the eyes for the given lens system. The system was retested using the mask and it was found to provide sufficient filtering to eliminate the blurring of the image.

### **3. Integrated Lens and Shutter Assembly**

Figure 3-11 is a photograph of the prototype device on an optical rail. The system consists of an objective lens, a focal plane mask, the LCD shuttering mechanism (including polarizers) and the collimating and focusing lenses. For integration with an endoscope, the entire device as shown on the optical rail must be fitted into a single, lightweight casing that can be attached to the end of the endoscope. The device requires only three electrical leads: one control line for each zone of the LCD shutter and a common ground line. The operation of the SVD is not sensitive to a rotation of the device about the optical axis, since any orientation will provide two views of the object.

### **4. Stereoglasses**

The lenses in the stereoglasses are made up of a liquid-crystal material sandwiched between two plane polarizers. The LCD lenses (or shutters) are driven by a battery powered circuit with a proprietary, oscillator-driven integrated circuit (IC) chip controlling the

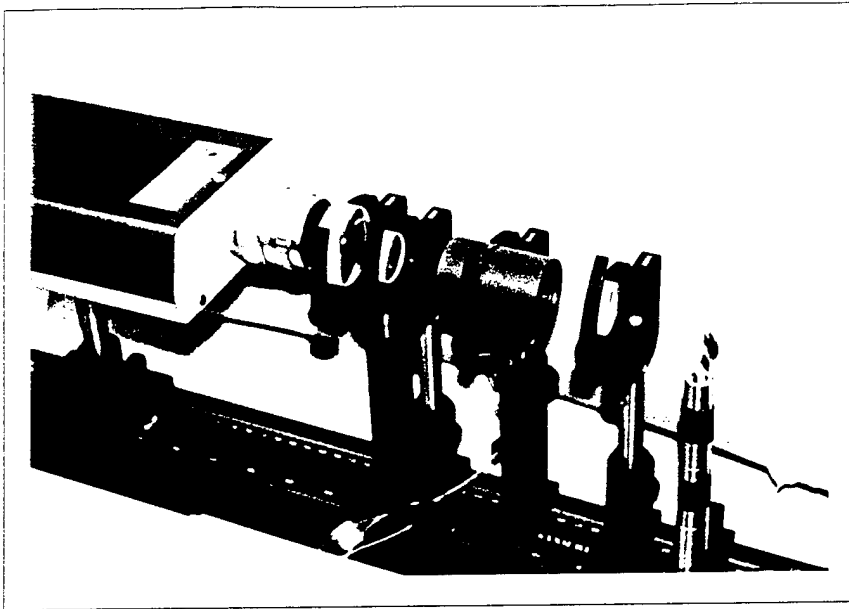

Figure 3-11. Photograph of Electro-optical Shuttering Device on an Optical Rail. On the far right is the object being viewed, then from right to left are the objective lens, the encased LCD shuttering device, the collimating lens, a focusing lens, and the camera

timing. The glasses are synchronized with the monitor via an IR emitter, usually located near the monitor, and an IR photodetector on the front of the glasses. The emitter is driven by a square wave derived from the camera signal, as described below.

The stereoglasses used in this thesis were designed for use with a two-camera system as discussed in Chapter II. Recall that for a two-camera system, a special monitor operating at 120 fps was viewed with the glasses, shuttering at 60 Hz. Our system required stereoglasses that operated at 30 Hz. It was determined that our off-the-shelf stereoglasses would not operate at this frequency. The glasses would not stay locked-in at the proper phase and frequency below about 32 Hz. In order to correct this problem, the internal circuitry of the glasses had to be modified. The glasses have a crystal oscillator that is used in the timing circuit. The factory-installed oscillator had a frequency of 32 kHz. We replaced this with a 30 kHz oscillator and found that the glasses could then operate at 30 Hz.

## 5. Synchronizing Circuit

The single-camera, stereoscopic video device consists of a lens and shutter assembly, a video camera and monitor operating at the standard NTSC rate, and a pair of stereoglasses for the viewer. These components must operate synchronously with the camera in order to allow the viewer to perceive three-dimensions; thus, a synchronization circuit was developed to control the frequency and phase at which both the LCD shutter and the stereoglasses operate.

A block diagram of the synchronizing circuit and the control signals and timing signals developed in the circuit are shown in Figure 3-12. The video signal from the camera, shown as timing diagram (a) in Figure 3-12, is sent both to a video synch-separator chip and to the video monitor. Each shaded block on this graph is a single video field, or, in our case, a single view of the object. The video synch-separator chip extracts a timing signal from the video signal and then outputs a 30 Hz TTL square wave at the frame rate of the video signal, as shown in timing diagram (b). This signal is called the "*odd/even field output*" of the synch-separator chip. The odd/even field output is then sent to the IR emitter for the stereoglasses to synchronize the glasses with the camera and monitor. This signal is also sent to a delay and duty cycle shift circuit which produces a signal that is both delayed in phase and modified in duty cycle. The phase delay and duty cycle can be varied, and one example of the outputs from this circuit is shown in timing diagrams (c) and (d). The shifted TTL signals are then amplified and sent to the two independently controlled zones of the LCD shutter as control signals. The control signal for the right zone of the LCD shutter is shown in timing diagram (e).

### *a. Synchronization of the Stereoglasses with the Monitor*

The stereoglasses were tested using the odd/even field output of the synch-separator chip to drive the IR emitter. It was found that with this signal, the stereoglasses were in-phase with the video monitor, and so no delay or duty cycle modification was required for the glasses. When viewing the video monitor with glasses that are not in-phase with the monitor, a black horizontal line will appear on the screen. This line indicates the

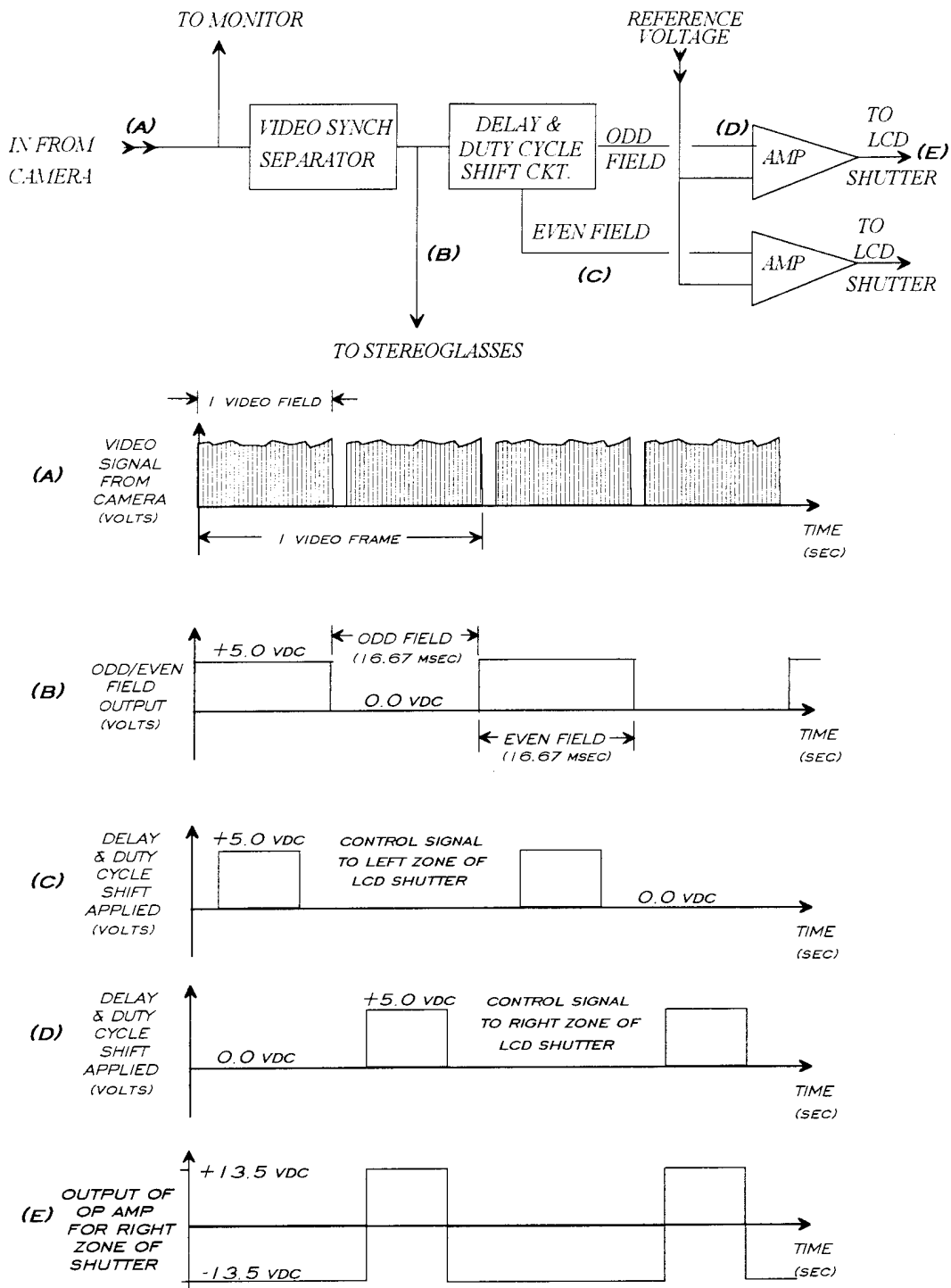

Figure 3-12. Block Diagram of Synchronization Circuit (top), and Timing Diagrams Showing the Control Signals Developed by the Circuit (bottom).

point at which the old image is fading and a new image is being illuminated on the monitor. When viewing the monitor with stereoglasses that are in-phase with the monitor, the black line is not visible.

*b. Synchronization of the LCD Shutter with the Camera*

Once the timing signal is produced, a delay and/or a duty cycle modification may have to be introduced to ensure that the LCD shuttering device is properly synchronized with the camera detector. The LCD shutter is phased to the camera detector to optimize the individual image clarity by passing only one view to the detector over one image collection field.

We used a programmable microcontroller to delay and modify the duty cycle of the signal from the separator chip. The microprocessor produces a delay that can be varied from 1.4 to 16.3 msec using an 8-pin dipswitch (256 possible delays, 58.2  $\mu$ sec each). The output of the delay circuit is fed into a duty cycle modification circuit. A variation in the pulse width of the square wave from 5 to 50% can be accomplished with this circuit.

The controller is a Parallax PIC 16C54, 18-pin microcontroller. The microcontroller is programmed in a proprietary object code on an IBM compatible personal computer. This object code is a near-assembly language instruction set which is then assembled to machine code and loaded into the microcontroller. [Ref. 26]

The programs for both the variable delay circuit and the duty cycle modification circuit are included in the Appendix. They were developed by Eric Conner of the NPS Physics Department. The circuit takes the TTL square wave output of the synch-separator chip and produces two outputs: (1) a square wave with a modified phase and pulse width, and (2) a second square wave identical to (1), but shifted in phase by 180°. Two outputs are necessary to provide a signal to each active zone of the in-line LCD shutter.

The final synchronizing circuit allows synchronization of the stereoglasses and both zones of the LCD shutter to the video monitor and camera detector. With the variable time delay and duty cycle, the SVD can be tested with various lighting conditions,

cameras, monitors, and lens configurations. The results of these tests are the subject of Chapter IV.



## IV. RESULTS

### A. TESTING OF THE PROTOTYPE STEREOSCOPIC DEVICE

The testing of each of the prototype SVD's developed for this thesis produced mixed results. A stereoscopic effect was evident with both the mechanically shuttered prototype and the electro-optically shuttered prototype, but the stereoscopic effect was only weakly discernible in most practical tests. The three-dimensional effect was verified by both student volunteers and NPS faculty members in a qualitative test of the device.

A simple depth perception test was also used to check for an improvement in depth perception with the SVD. The test consisted of viewing identical objects that were slightly offset. The objects were viewed on the video monitor both with and without the SVD. All of the participants failed to distinguish the proper relative depth between the objects when no SVD was used. With the SVD, three out of four subjects were able to positively establish the relative depth of one object with respect to the other on several trials. One subject reported seeing no three-dimensional effect.

### B. PROBLEMS ENCOUNTERED DURING TESTING

The achievement of stereoscopic vision from a single-camera video device, while significant, did not accomplish all of the objectives of the research. One of our goals was the development of an SVD that could meet realistic teleoperations demands in the space environment. The prototype SVD has not yet met these requirements. The following problems arose in preliminary testing which must be solved prior to any in-depth, functional testing of the device can be performed: (1) shadowing of the image, and (2) flicker of the video image.

#### 1. Shadow Images in the Video Picture

The main problem with the current SVD is the occurrence of *shadowing*. Shadowing is the appearance of a faint image of the alternate video field when viewing the other field on the monitor. Shadowing could be due to a long time constant for the phosphor decay on the monitor, or to improper synchronization between the LCD shutter and

the camera. Improper synchronization of the stereoglasses was ruled out based on the synchronization tests for the glasses discussed in Chapter III. Based upon these same tests, we do not believe the problem is the monitor either. A sufficient phosphor decay rate is evident in the fact that the black horizontal strip is present on the monitor when the glasses are out-of-phase with the stereoglasses. This strip shows the fading of the previous field *prior* to the next field being scanned onto the screen.

In order to determine the cause of the shadowing, tests were performed using a strobe light as the sole illumination source for the object being viewed. The strobe light was driven by the synchronizing circuit at 30 Hz such that the strobe light was in-phase with the rising edge of the square wave synchronizing pulse as verified by an oscilloscope. The testing of the SVD using the strobe light revealed that the video camera was transmitting an illuminated view for both the in-phase field and the out-of-phase field. This shadowing could not be removed at any setting of the variable time delay and duty cycle modification circuit controlling the LCD shutter. This indicates that the camera has an integration time which is incompatible with the LCD shutter. A second camera was tried with similar results. More work is required to understand the shadowing problem.

## **2. Flicker in the Video Picture**

The second problem that arose when testing the prototype SVD was the appearance of flicker. As discussed in Chapter II, flicker in the image at a rate below the critical flicker frequency (CFF) may cause a degradation or complete loss of the stereopsis effect. The amount of this degradation is difficult to quantitatively determine because of the presence of shadowing in the image.

The CFF is dependent on several test-specific variables, such as the illumination intensity on the object, the object contrast, the solid angle bisected by the object at the eye, and the specific image and timing characteristics of both the camera and video monitor. Additionally, CFF varies from person to person over a relatively large range of frequencies. [Ref. 11] For these reasons, specific values of the CFF for the various test conditions were not determined.

Stereopsis was perceived by several test subjects during preliminary testing of the SVD. This suggests that the SVD is indeed operating at a frequency slightly above the CFF. Nevertheless, the presence of flicker was reported as objectionable by some subjects. Again, this problem is coupled to the problem of shadowing in the image. Further testing of the influence of flicker on the stereopsis process must be performed when the shadowing problem is resolved.

### **3. Transmission Losses Through the Shuttering Mechanism**

One further problem which arises in the use of LCD shutters for optical video systems is the 50% to 60% transmission loss in the shuttering system in the transparent state. This is primarily due to the fact that the light must be plane polarized prior to entering the LCD shutter (this accounts for slightly over 50% of the transmission loss). The additional 10% loss in transmission is due to the chromatic selectivity of the particular LCD shutter.

The transmission characteristic of the LCD is shown in Figure 3-10 in Chapter III. While the shutter itself passed nearly 100% of the incident polarized light at about 530 nm, this transmission dropped to 50% at the near-ultraviolet end of the spectrum (420 nm) and to 80% at the near-infrared end of the spectrum (690 nm). The average loss of light due to the LCD shutter over the visible band is approximately 10%.

Although the 50% loss of light due to the plane polarizer is not recoverable in this SVD, the 10% loss due to chromatic selectivity in the LCD shutter can be significantly reduced. An achromatic LCD shutter, which has transmission near 100% over the entire visible region of the light spectrum, is available through Boulder Nonlinear Devices.



## **V. CONCLUSIONS & RECOMMENDATIONS**

### **A. CONCLUSIONS**

A real-time, single-camera, stereoscopic video device was developed for use with a standard video camera and monitor. The device uses a lens system and LCD shuttering mechanism to present alternating views of the object to the camera detector. The alternating views are presented to the video monitor at the standard video field rate. Specially modified stereoglasses allow each eye to perceive every other video field as displayed on the monitor. The result is that only one view of the object is presented to each eye, which permits the perception of depth in the brain through the process of binocular stereopsis.

Testing of the prototype stereoscopic device on an optical rail produced a mild stereoscopic effect in most cases. One test subject reported no stereoscopic effect. The quality of the image was poor due to transmission losses through the LCD shuttering mechanism, flicker apparent in the video image, and shadowing of the alternate view onto the image on the video monitor. Testing indicated that the source of the shadowing problem was the camera detector. Future testing of the SVD with a higher quality camera detector is required.

### **B. RECOMMENDATIONS FOR FUTURE RESEARCH**

The presence of a stereoscopic effect using the prototype SVD has been shown. Furthermore, the quality of the image has been improved by the addition of the focal plane mask and the time delay to the LCD shutter. The next step in the development of a functional stereoscopic video device is to test the SVD on a specific device, such as an endoscope. The synchronization of the LCD shutter is dependent upon the characteristics of the particular camera detector used. Thus, once an endoscope detector is available, further experimentation can be performed to determine the optimal phase delay and duty cycle for the LCD shutter. With these results in hand, the synchronizing circuit can be simplified (since the time delay and duty cycle can now be fixed with one microcontroller chip) and miniaturized for integration with the shutter device.

Further research in ways to remove the shadow image from the video picture is also necessary. The problem may be resolved with the use of a higher quality camera detector. With the shadow image removed, further testing can be performed to determine whether the flicker in the image is causing significant degradation in the stereopsis effect. One possible solution to the flicker problem is the move to a high speed camera and monitor. This option would require specialized equipment and may limit the advantages inherent in the SVD as designed.

Additional testing of the SVD on a larger control group is not recommended until the shadowing problem is resolved. The testing of the device on a practical level must be performed at the optimum time delay for the LCD shutter mechanism to obtain a substantive evaluation of the future potential for the SVD. If the shadowing on the video monitor can be removed, a more distinct stereoscopic effect may be present. This will allow the determination of the optimum phase delay of the LCD shutter.

The testing performed for this thesis used a lens system which was developed for close-up viewing applications. Because of the objective lens size (25 mm in diameter) and the small depth-of-field of the system, the size of the object that could be viewed was limited to less than 25 mm. In order to view a larger object from the same viewing angles, the diameter of the objective lens in the SVD must be increased. To view an object at a greater distance from the device, a lens system with a larger focal length is required, and the focal plane mask may need to be adjusted to capture the desired viewing angles.

## APPENDIX. COMPUTER CODE FOR SYNCHRONIZING CIRCUIT

The computer code for the time delay and duty cycle modification circuit is written in a proprietary code developed by Parallax, Incorporated. The code is compiled into assembly language and downloaded into a Parallax PIC 16C54 microcontroller. The first program is the time delay program and the second program is the duty cycle modification circuit.

### 1. Time Delay Program

```
;THIS PROGRAM DELAYS A 30 HZ SQUARE WAVE FROM 1.4 mSEC TO
;16.3 mSEC (FROM IN PHASE TO INVERTED)

        DEVICE PIC16C54,XT_OSC,WDT_OFF,PROTECT_OFF

        RESET START
        ;;;;;;;;;;DECLARATIONS;;;;;;;;;;;;;
DELAY    EQU        RB

INPUT    EQU        RA.2
OUTPUT   EQU        RA.3

LOOK     EQU        08H
DLY2     EQU        09H
N1       EQU        0AH
N2       EQU        0BH
N3       EQU        0CH

START    MOV        !RA,#0100b        ;MAKE BIT 2 AN INPUT, BIT 3 AN
OUTPUT                                       ;
        MOV        !RB,#11111111b    ;SETUP REG B AS INPUTS
        MOV        LOOK,#2           ;LOOK=2

WAIT     JNB        INPUT,WAIT        ;WAIT TIL POS INPUT TRIGGER
        DJNZ       LOOK,WAIT         ;SAMPLE 2 TIMES TO ENSURE NOT
GLITCH                                       ;
        JB         RB.7,LDLY
        LCALL      PHASE             ;PHASE DELAY SUBROUTINE
        LCALL      GEN               ;GENERATE PULSE WIDTH SUBROUTINE
        LJMP       WAIT              ;START OVER
LDLY     LCALL      LPHS
        LCALL      LGEN
```



```

OUTPUT EQU RA.3

LOOK EQU 08H
DLY2 EQU 09H
N1 EQU 0AH

START MOV !RA,#0100b ;MAKE BITS 2 INPUT, BIT 0, 1, & 3
OUTPUTS
      MOV !RB,#11111111b ;SETUP REG B AS INPUTS

WAIT JNB INPUT,WAIT ;WAIT TIL POS INPUT TRIGGER
      CALL PULSE ;GEN PULSE SUBROUTINE
      JMP WAIT

;;;;;;;;;;;;;0-16 mSEC PULSE SUBROUTINE;;;;;;;;;;;;;
PULSE SETB RA.3
      MOV DLY2,DELAY

LOOP3 MOV N1,#8
LOOP1 DJNZ N1,LOOP1
      DJNZ DLY2,LOOP3
      CLRB RA.3

WAIT2 JB INPUT,WAIT2
      SETB RA.0
      MOV DLY2,DELAY

LOOP2 MOV N1,#8
LOOP4 DJNZ N1,LOOP4
      DJNZ DLY2,LOOP2
      CLR RA.0
      RET

;;;;;;;;;;;;;END;;;;;;;;;;;;;

```



## LIST OF REFERENCES

1. Drascic, D., Grodski, J., "Using Stereoscopic Video For Defense Teleoperation," *SPIE Vol. 1915, Stereoscopic Displays and Applications IV*, pp. 58-68, San Jose, CA, 1993.
2. Cole, R. E., Merritt, J.O., Fore, S., Lester, P., "Remote Manipulator Tasks Impossible Without Stereo TV," *SPIE Vol. 1256, Stereoscopic Displays and Applications*, pp. 255-265, Santa Clara, CA, 1990.
3. Merritt, J.O., "Visual Tasks Requiring 3-D Stereoscopic Displays," *SPIE Vol. 462, Optics in Entertainment II*, pp. 56-59, Los Angeles, CA, 1984.
4. Baker, K., Murray, H., "3-D Considerations and Facts in Entertainment," *Optics & Photonics News*, vol. 4, no. 6, pp. 11-12, June 1993.
5. Lipton, L., "Stereoscopic Real-Time and Multiplexed Video System," *SPIE Vol. 1915, Stereoscopic Displays and Applications IV*, pp. 6-11, San Jose, CA, 1993.
6. Butterfield, J. F., "Survey of Three-Dimensional Television," *SPIE Vol. 212, Optics & Photonics Applied to Three Dimensional Imagery*, pp. 40-47, Strasbourg, France, 1979.
7. Lipton, L., "Selection Devices for Field-Sequential Stereoscopic Displays: a Brief History," *SPIE Vol. 1457, Stereoscopic Displays and Applications II*, pp. 274-282, San Jose, CA, 1991.
8. Pettigrew, J. D., "The Neurophysiology of Binocular Vision," *Scientific American*, vol. 227, no. 2, pp. 84-95, August 1972.
9. Mayhew, C. A., "A 35 mm System for Live-Action Imaging Using a Single Camera and Lens," *SMPTE Journal*, pp. 505-511, June 1993.
10. Southall, J. P. C., *Introduction to Physiological Optics*, Oxford University Press, New York, 1937.
11. Bartlett, N. R., Brown, J. L., Hsia, Y., Mueller, C. G., Riggs, L. A., in Clarence H. Graham, ed., *Vision and Visual Perception*, John Wiley & Sons, Inc., New York, 1966.
12. Owens, D. A., "The Resting State of the Eye," *American Scientist*, Vol. 72, No. 4, pp. 378-387, July-August, 1984.

13. Miller, P. F., Mitchell, T., "2D / 3D Comparison Using Commercial Vision Products," *SPIE Vol. 1256, Stereoscopic Displays and Applications*, pp. 272-279, Santa Clara, CA, 1990.
14. Spain, Edward H., "Stereo Advantage for a Peg-in-Hole Task Using a Force-Feedback Manipulator," *SPIE Vol. 1256, Stereoscopic Displays and Applications*, pp. 244-254, Santa Clara, CA, 1990.
15. Mowafy, L., Thurman, R. A., "Training Pilots to Visualize Large-Scale Spatial Relationships in a Stereoscopic Display," *SPIE Vol. 1915, Stereoscopic Displays and Applications IV*, pp. 72-81, San Jose, CA, 1993.
16. McLaurin, A. P., Jones, E. R., Mason, J. L. Jr., "Three Dimensional Endoscopy Through Alternating-Frame Technology," *SPIE Vol. 1256, Stereoscopic Displays and Applications*, pp. 307-311, Santa Clara, CA, 1990.
17. McLaurin, A. P., Jones, E. R., Mason, J. L. Jr., "A Three Dimensional Imaging Laproscope," *SPIE Vol. 1457, Stereoscopic Displays and Applications II*, pp. 318-321, San Jose, CA, 1991.
18. Taylor, D. L., Nederlof, M., Lanni, F., Waggoner, A. S., "The New Vision of Light Microscopy," *American Scientist*, Vol. 80, No. 4, pp. 322-334, July-August, 1992.
19. Dumbreck, A. A., Abel, E., Murphy, S., "3-D TV System for Remote Handling: Development and Evaluation," *SPIE Vol. 1256, Stereoscopic Displays and Applications*, pp. 226-236, Santa Clara, CA, 1990.
20. Xu, Y., Chiayu, A., "New Realistic 3-D Surface Microtopography Visualization Technique," *SPIE Vol. 1915, Stereoscopic Displays and Applications IV*, pp. 21-28, San Jose, CA, 1993.
21. Parker, L., "The History of Stereoscopy in Art, Science, and Entertainment," *SPIE Vol. 391, Optics in Entertainment*, pp. 23-26, Los Angeles, CA, 1983.
22. Saleh, B. E. A., Teich, M. C., *Fundamentals of Photonics*, John Wiley & Sons, Inc., Toronto, 1991.
23. Shields, S. E., "The Allure of Liquid Crystal Displays," *Optics & Photonics News*, Vol. 5, No. 3, pp. 12-18, March 1994.
24. Depp, S. W., Howard, W. E., "Flat-Panel Displays," *Scientific American*, Vol. 266, No. 3, pp. 90-97, March 1993.

25. *CRYSTALEYES® Stereoscopic System User's Manual*, StereoGraphics® Corp., San Rafael, CA, 1992.
26. *Parallax PIC 16Cxx Development Tools User's Manual, Version 2.2*, Parallax Inc., 1992.



## INITIAL DISTRIBUTION LIST

	Number of Copies
1. Defense Technical Information Center Cameron Station Alexandria, Virginia 22304-6145	2
2. Library, Code 52 Naval Postgraduate School Monterey, California 93943-5101	2
3. Dr. D. D. Cleary Physics Department, PH/C1 Naval Postgraduate School Monterey, California 93943-5002	3
4. Dr. O. Biblarz Department of Aeronautics & Astronautics, AA/Bi Naval Postgraduate School Monterey, California 93943-5106	1
5. Dr. R. Panholzer, Chairman Space Systems Academic Group, Code SP Naval Postgraduate School Monterey, California 93943-5106	1
6. Dr. D. J. Collins, Chairman Department of Aeronautics & Astronautics, AA/Co Naval Postgraduate School Monterey, California 93943-5106	1
7. Dr. W. B. Colson, Chairman PH Department of Physics Naval Postgraduate School Monterey, CA 94943-5002	1
8. LT Blake L. Converse 520 South 5 <sup>th</sup> Street North Wales, PA 19454	2