

NATIONAL AIR INTELLIGENCE CENTER

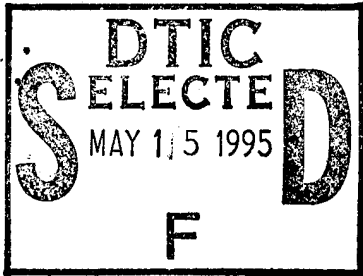

THERMAL CONTROL TECHNOLOGY OF COMMUNICATIONS SATELLITE
(Selected Articles)

by

Guo Jiurong



DTIC QUALITY INSPECTED 8

19950512 068

Approved for public release;
Distribution unlimited.

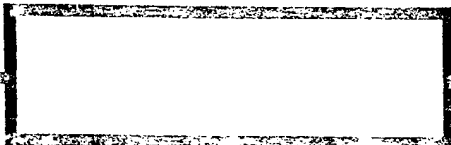

HUMAN TRANSLATION

NAIC-ID(RS)T-0562-93 13 April 1995

MICROFICHE NR: 95C 000199

THERMAL CONTROL TECHNOLOGY OF COMMUNICATIONS SATELLITE
(Selected Articles)

By: Guo Jiurong

English pages: 22

Source: Zhongguo Kongjian Kexue Jishu, Nr. 1, 1990; pp. Title;
14-20; 45-51

Country of origin: China

Translated by: Leo Kanner Associates
F33657-88-D-2188

Requester: NAIC/TATV/Capt Ernest S. Muller

Approved for public release; Distribution unlimited.

THIS TRANSLATION IS A RENDITION OF THE ORIGINAL FOREIGN TEXT WITHOUT ANY ANALYTICAL OR EDITORIAL COMMENT STATEMENTS OR THEORIES ADVOCATED OR IMPLIED ARE THOSE OF THE SOURCE AND DO NOT NECESSARILY REFLECT THE POSITION OR OPINION OF THE NATIONAL AIR INTELLIGENCE CENTER.

PREPARED BY:

TRANSLATION SERVICES
NATIONAL AIR INTELLIGENCE CENTER
WPAFB, OHIO

GRAPHICS DISCLAIMER

All figures, graphics, tables, equations, etc. merged into this translation were extracted from the best quality copy available.

Accession For	
NTIS CRA&I	<input checked="" type="checkbox"/>
DTIC TAB	<input type="checkbox"/>
Unannounced	<input type="checkbox"/>
Justification	
By	
Distribution /	
Availability Codes	
Dist	Avail and/or Special
A-1	

THERMAL CONTROL TECHNOLOGY OF COMMUNICATION SATELLITE

Guo Jiurong, Beijing Institute of Spacecraft Systems
Engineering

Abstract This paper briefly describes status quo and recent prospects on thermal control technology of communications satellites. A discussion of several problems on heat radiators and other thermal control elements is given.

Subject Term Temperature control, Communication Satellite, Design.

Over the past more than two decades, many communication satellites entered geosynchronous orbits, fixed over the equator at different positions. These satellites adapt to features of two kinds of geostationary satellites: spin stabilization and three-axis stabilization. In addition, the thermal control technology has seen great progress with growing maturity with the passage of time. However, an undeniable fact is that there is a new challenge confronting thermal control technology in recent years [1, 2], with the gradual development of communication satellites.

I. Foreword

As is well-known, to ensure necessary spacing between geostationary satellites, there is a limited number of positions in which a geostationary orbit can be used. It is not allowed to launch an unlimited number of geostationary satellites. In addition, given the steady rise in development costs and launch expenditures for satellites and carrier rockets, the current communication satellites are trending to become larger and larger; an appreciable increase in the number of channels; greater output power for each channel; and the power of the overall satellite increases severalfold. For example, INTELSAT IV in the seventies had 12 channels; the satellite power at the end of its service life was about 460W. In the eighties, INTELSAT VI has 42 C-band TWTA, 15 C-band SSPA, and 20 K-band TWTA, for a total of 77 channels. The total satellite power was still higher than 2200W even at the end of its service life. Apparently, the thermal control subsystem strives for breakthroughs in two aspects (greater heat dissipation capability and upgraded heat dissipation efficiency) in order to meet the demands of the nineties and later.

Prolonging satellite service life is an important route for better economic effects from investments. In the early periods, the designed service life for communication satellites were 3-5 years, or 5-7 years; in recent years, the design service life was set to a range of 8-10 years. There are many difficult problems facing the thermal control subsystem of long-lived satellites.

First, the performance of the thermal control coating layer of the radiator is degraded; the solar energy absorption rate of the coating layer increases to some extent during the satellite's in-orbit operational period. Therefore, satellites are showing a trend toward higher temperatures, which leads to uneasiness among designers. Moreover, the rise in the amount of fuel carried by a satellite is important in prolonging service life. Thus, there is a requirement that all subsystems reduce their mass. However, the gradually extensively adopted various kinds of lightweight structure are not beneficial to thermal conduction. With respect to those high values of heat dissipation quantities (heat flow density), special measures should be adopted for instruments and equipment to strengthen heat conduction.

It is worth emphasizing that there are also problems of thermal control indicators for instruments and equipment; the most typical is the storage battery. In early periods, generally the temperature indicators of Cd-Ni batteries were determined as being between 0 and 30°C. Recently, many satellites require temperature control of Cd-Ni or Ni-H batteries to be within the range 0 and 15°C (or even a narrower range); strict control indicators are imposed on the temperature difference between battery cells and the temperature difference between battery sets. Requirements cannot be satisfied by relying only conventional passive measures of thermal control. Complexly active (or even with remote control) thermal control measures should be added.

For upgrading satellite reliability in long service operation, strict specifications are made on residual heat in design with respect to the related design criteria and experimental norms. It is required to set predetermined temperatures* for the case of extreme high temperature conditions; such predetermined temperatures should be at least 110C lower than the maximum temperature limit specified for the mission. The predetermined temperature for extreme low temperature conditions should be at least 110C higher than the low temperature limit. Thus, the design scope is greatly compressed. It is required to have higher precision for thermal analytical computations and ground simulation tests.

It can be seen that this is an urgent requirement to rapidly upgrade the technical level of thermal control for communication satellites.

II. Major Thermal Control Measures

Major thermal control measures adopted recently for communication satellite are as follows: 1. coating layers of isothermal control on secondary surfaces, 2. multilayer heat-insulating materials, 3. heat pipes, and 4. electric heat heating devices.

* The predetermined temperature is the temperature value obtained from thermal analytical computations and ground thermal equilibrium tests; the predetermined temperature is also referred to as the pre-indicated temperature, or design temperature.

1. Thermal control coating layer

For a given satellite, the temperature level of the overall satellite is determined, to a great extent, by the solar energy absorption rate (α) and the infrared emission rate (ϵ) of satellite surfaces. It is vital to correctly select thermal coating layers.

At present, a quartz glass silver coated secondary surface mirror (briefly called, OSR) is the most ideal thermal control coating layer for radiators on long-life communication satellites, as being the unanimous view in China and abroad. The outstanding advantages of the coating layer include its low α , but its high ϵ ; relatively speaking, the performance is comparatively stable, capable of effectively dissipating waste heat from the satellite. Even though there is performance deterioration (slowly increasing α) of the OSR during the in-orbit operating period, the overall satellite temperature rises; this problem still poses serious problems for thermal designers. As shown in Fig. 1, the solar energy absorption rate of OSR generally increases exponentially. The annual increase $\Delta\alpha$ is between 0.01 and 0.02. However, this monitoring value is not entirely uniform for a number of satellites; thus, the role of regeneration has not been really mastered. There are numerous views about the analysis of the degradation regime; further discussion is required. In practical design work, currently, ϵ equal to approximately 0.8, the initial value of α being between 0.06 and 0.08, and the

value of the end-of-service for a ten year period is as high as 0.25, as generally used at present.

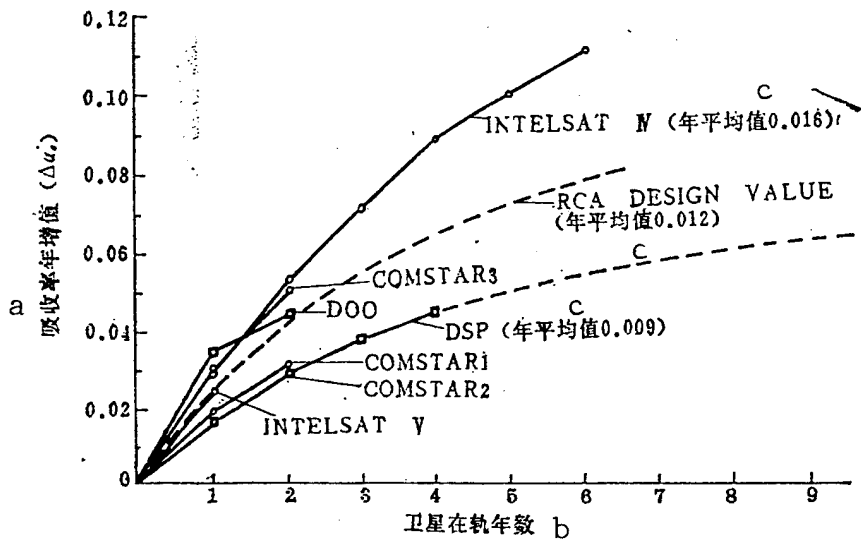

Fig. 1. Increase of solar energy absorption rate of OSR during orbiting period

KEY: a - annual increase in absorption rate
 b - years spent by satellite in orbit
 c - annual mean value

Currently, thermal control layers with better stability in space are actively being sought for; for example, the Ag/PEI/CeO₂ coating layer (a silver-coated secondary surface mirror with a PEI thin film coated with evaporating CeO₂) has desirable anti-radiation performance; such coating layer may possibly become a useful soft-type thermal control coating layer. Another type of SAS (silver-alumina-silica) coating layer exhibits excellent stability in preliminary tests on synchronous orbits and ground measurements.

The problem of the degeneration of the solar energy absorption rate for present-day OSR directly restricts the heat dissipation capability of radiators. Researchers expect that in

the near future, new thermal control coating layer types will have alphas at the end period of a 10-year service life being less than 0.20.

After years of practice, the conventional thermal control coating layers at other communication satellite sites gradually concentrate in the items listed in Table 1. In these items, there are different absorption rates and emission rates.

TABLE 1. Other Coating Layers Usually Used on Communication Satellites

涂层名称 1	α_i	ϵ_H	涂层名称 5	α_i	ϵ_H
铈玻璃镀银二次表面镜 2	~0.10	~0.80	铝光亮阳极氧化 6	~0.12	0.2~0.8
Ag/Teflon薄膜 3	~0.10	~0.60	铝黑色阳极氧化 7	~0.9	~0.9
Al/Teflon薄膜 3	~0.14	~0.60	白漆 8	~0.2	~0.8
Al/Kapton薄膜 3	~0.40	~0.70	铝粉(灰)漆 9	0.2~0.4	0.2~0.4
镀金 4	~0.26	~0.05	黑漆 10	~0.9	~0.9

KEY: 1 - name of coating layer 2 - cerium glass silver-coated secondary surface mirror 3 - thin film 4 - gold coating 5 - name of coating layer 6 - oxidation of bright aluminum anode 7 - oxidation of black aluminum anode 8 - white paint 9 - aluminum powder (gray) paint 10 - black paint

2. Multilayer heat insulating materials

Widely applied in communication satellites are multilayer heat-insulating materials that are laminated by multilayer aluminum polyester coating thin films and appropriate separation materials (such as dacron and nylon fabrics). Under good control conditions at the laboratory level, the equivalent emission rate ϵ_{eff} (the equivalent emission rate of multilayer heat-insulating materials) may reach 0.005. However, in practical applications, oftentimes ϵ_{eff} is as high as 0.05 because of multiple factors of seaming, openings and installations. A lower equivalent emission rate cannot be attained by simply adding to the number of layers. Because the greater the density of layers, the more the contact points between layers there are when a certain limit is exceeded, thus increasing direct thermal conduction and lowering the performance of heat insulation.

At sites of higher temperatures in rocket engines and attitude control engines at apogee, intermediate temperature or high temperature multilayer heat insulating materials are used. They are laminated with separation layers of aluminum polyimide thin film or nickel foil as insulation screen, or high silica fabric.

3. Heat pipes

Heat pipes are a component for transmitting heat that relies on evaporation, condensation, and circulation flow of the working medium; the thermal conductivity exceeds, by a wide margin, that

of metal rods with the same dimensions. In other words, the thermal conductivity of a heat pipe is greater by a factor of a hundred or even a thousand times. There are no moving parts in a heat pipe, thus not requiring energy consumption. Along with their compact structure and reliable operation, heat pipes are especially adaptable to applications in space. From Fig. 2 we know that by citing an example of the RCA-STC direct broadcasting satellite (DBS), the adoption of heat pipes results in much lighter weight than the conventional aluminum heat expansion plate; this is an outstanding property of heat pipes.

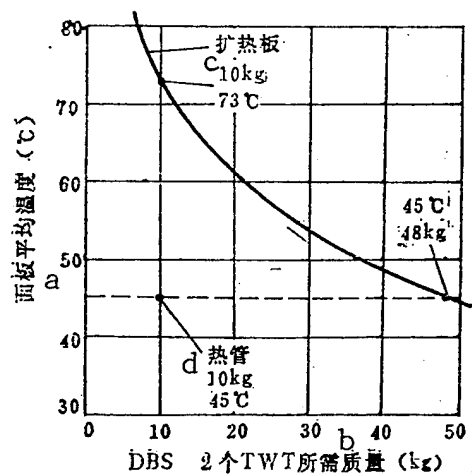

Fig. 2. Comparison between DBS heat pipe and expanded heating plate
 KEY: a - mean temperature of panel b - mass required for 2 TWT c - expanded heating plate d - heat pipe

China successfully applied heat pipes in a number of communication satellites with spin stabilization. As indicated with five continuous years of monitoring results, up to now the properties of heat pipes have been stable, along with good results. Worth emphasizing is the fact that the installation

sites of heat pipes in spin satellites should be cautiously selected in order to strictly control the trend of satellites.

In recent years we have seen widespread applications of constant thermal conduction heat pipes (FCHP) in three-axis stabilized satellites made abroad. As an active type of thermal control measure, variable conduction heat pipes (VCHP) are being gradually emphasized. The main installation type involves burying the heat pipes in instrument panels of honeycomb structure [3].

4. Electric heating devices

In communication satellites in China and abroad, almost without exception thermal heating devices are used as an important thermal control measures.

There are mainly the two following types of electric heating devices up to now: one is the polyimide-F46 type electric heating sheets (bands) with extensive application for thermal control of instruments and equipment in satellites. The second is the armored high-temperature electric heating wire, which can be wound on high temperature components of attitude control rocket engines.

With regard to the application of electric heating devices, there are generally the four following situations:

- i. there is constant heating power without adjustment capability; this is simply a passive type of thermal control measure;

ii. matching with electronic or mechanical types of isothermal controllers, there is automatic adjustment capability with temperature feedback; this is an active type thermal control measure;

iii. subsequently utilized properties of measurement and control in all times in geostationary satellites, ground commands are used for remote control of the operation of electric heating devices;

iv. for reliability of electric heating devices there are two functions of automatic adjustment and remote control. This is the major aspect of using electric heating devices in communication satellites.

III. Site Selection of Radiators

When selecting radiator installation sites in order to dissipate waste heat of hundreds or even thousands of watts into outer space, this is the key problem in thermal design of communications satellites.

1. Spin-stabilized satellites

Citing examples of tactical communication satellites (TACSAT-1) of the United States Air Force and INTELSAT-IV launched in the early years, radiators as the main heat dissipating surfaces were situated at the top end of cylindrical satellites, near the antennas; this is usually called the solar screen. Accounting for 90% of power consumption for the entire

satellite, payloads are concentrated and installed in the spin-eliminating platform; most waste heat is dissipated through the solar screen. The external surfaces of the solar screen are in two kinds of thermal control coating layers: quartz glass silver-coated secondary surface mirrors and F46 thin film aluminum-coated secondary surface mirrors.

In fact, this is not the most ideal scheme in selecting the solar screen at the top of a satellite as the main heat dissipation surface.

First, there are antennas of different shapes installed near the solar screen; the antennas are growing increasingly complicated, thus seriously affecting the heat dissipation efficiency of the solar screen. Whether analytical computations or ground simulation experiments, the heat coupling relationships between solar screen and antennas should be clarified; this is difficult, to some extent, thus increasing errors in thermal design.

Secondly, there are the apparent seasonal variations for the solar incident angle of a geostationary satellite. From the vernal equinox to the summer solstice, the solar screen was first not directly illuminated by sunlight, then gradually becoming illuminated. From summer solstice to autumn equinox, the solar screen was first illuminated, then gradually became unilluminated. From the autumn equinox to the vernal equinox of the following year, through the winter solstice, the solar screen is consistently not directly illuminated by sunlight. Because of

the effects of external heat flow, temperatures on the external surfaces of the solar screen fluctuate, to a considerable extent. This situation is obviously disadvantageous to the main heat dissipation surfaces.

In addition, with the expansion of satellite functions, the number of channels is gradually increasing, along with increased power. However, the area of the solar screen is determined by the satellite diameter, and is restricted by the interior volume of the carrier rocket. Thus, the solar screen is gradually unable to meet application requirements.

In the mid-seventies, when China prescribed thermal control schemes of its experimental communication satellite, a decision was then made not to use the popular screen then used abroad with the solar screen as the main dissipation surface. In China it was then decided that a special waistband radiator in the cylindrical section be used for heat dissipation [4]. The advantage of this scheme is that the waistband is consistently under sunlight illumination except for the shadow zone; no interference with other components exists, along with small variation in amplitude of temperature. Thus, the layout is advantageous to temperature control of instruments and equipment in the satellite. Besides, heat-insulating measures are added at the solar screen; thus, the effect on the satellite interior by the external surface temperature is reduced to the minimum.

In recent years, new types of large volume, spin-stabilized communication satellites were launched, such as the Anik-D and

the INTELSAT-VI. In these satellites, the design does not use a solar screen as the main heat dissipation surface, as it is generally considered that the heat dissipation efficiency of this channel is low. In these satellites, without exception radiators with a certain surface areas are installed in the satellite's cylindrical segment as the main heat dissipation surfaces. The coating layer on the external surfaces is quartz glass, silver-coated secondary surface mirrors.

Generally speaking, the height of the cylindrical-segment radiator is relatively little affected by the carrier rocket, because in this scheme there is greater adaptation capability and good developmental prospects.

By simplifying the spin-elimination platform and the radiator into heat exchange between two concentric cylindrical surfaces, as indicated in computations, when the density of the waste heat power of the spin-elimination platform is approximately between 120 and 160W/m², the temperatures under various operating conditions can be maintained within the range 0-40°C.

2. Three-axis stabilized satellites

At present, the vast majority of three-axis stabilized communication satellites are cylinders with rectangular cross section. It is usually selected to install radiators at the south/north panels, as the main heat dissipation surfaces. Because also there are seasonal variations of the solar angle

within a year for the south/north panels, yet the solar angle in a day remains almost constant. For other surfaces, whether the east/west lateral surfaces, the ground-facing surface, or the surface with its back to the ground, there are not only seasonal variations in the solar angle, but also there are obvious diurnal variations. The fluctuation amplitude of external heat flow is high, thus not adaptable as the main heat dissipation surface. Generally, multilayer heat insulating material is used as the cover, as treatment of the adiabatic surfaces. As indicated in simple calculations, when the waste heat power density of the south/north panels is approximately between 240 and 260W/m², all temperatures under various operating conditions are maintained within a range 0-40°C.

The external dimensions (of the satellite), including the surface area of the south/north panel radiators are restricted by the internal volume of the carrier rocket. In coping with the rapid increases in power for the overall satellite, we should seek a route for further increasing heat dissipation capability. In other words, when the satellite external dimensions (for a certain internal volume) remain constant, it is thought to install more payloads without overheating.

In the cases of ATS-6 and TV-SAT, heat pipes are used to connect the south/north panels [5], as shown in Fig. 3. As is well known for the north panel of a three-axis stabilized satellite, when sunlight illuminates directly on the panel during the summer solstice season, and during the winter solstice

season, the panel is not under solar illumination. For the south panel, the situation is just the opposite. If not considering the effect of the solar cell sail panel, the heat equilibrium equation is as follows during the winter solstice (summer

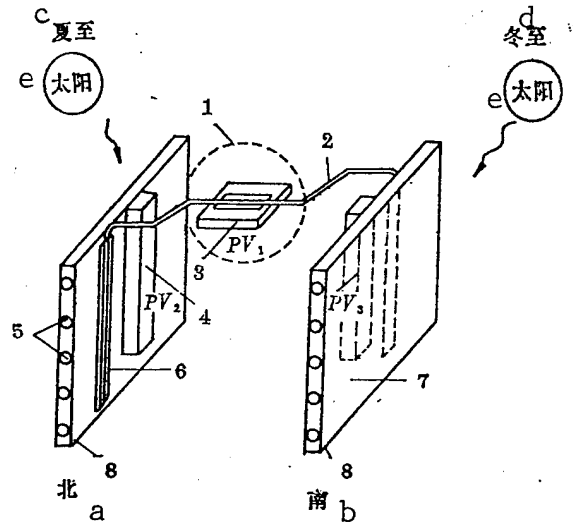

Fig. 3. Schematic diagram of south/north panels connected with heat pipe
 LEGEND: 1 - heat-insulating measure 2 - connecting heat pipe 3 - output multiplexer 4 - traveling-wave tube 5 - heat pipe buried within panel 6 - connecting heat pipe 7 - panel 8 - heat pipe radiator
 KEY: a - north b - south c - summer solstice d - winter solstice e - sun

solstice, in the case of the north panel) for the south panel without connecting both panels:

$$\alpha_s \cdot S \cdot \sin 23.5^\circ + q = \sigma \epsilon T^4 \quad (1)$$

In the equation, alphas represents the solar energy absorption rate;

S represents the solar constant (W/m2);

q represents the waste heat power density (W/m2) on the

panel;

sigma represents a constant ($5.7 \cdot 10^{-8} \text{ W/K}^4 \cdot \text{m}^2$);

epsilon represents the infrared emission rate; and

T represents temperature (K).

After connecting the south/north panels with a heat pipe, the heat equilibrium equation is as follows for the ideal case for the winter solstice or the summer solstice:

$$\frac{1}{2}(\alpha \cdot S \cdot \sin 23.5^\circ) + q = \sigma \epsilon T^4 \quad (2)$$

Obviously, under conditions of the same temperature, in the latter case it is allowed that the density of the waste heat power will be increased, to some extent. For example, when the upper temperature limit is 40°C , the value of q can attain the vicinity of 330 W/m^2 .

By adding a radiator with deployable solar screen at the south/north panels, this scheme has certain prospects, referring to Fig. 4. Although the deployable mechanism (such as hinges and others) has been extensively applied at the antenna and solar cell sail panel, however, the highly efficient connecting technique of heat boundary surfaces should be solved. Under development are the soft trunk line pipe core heat pipe and the coaxial heat pipe rotating joint for shielding metallic corrugated pipe in order to have sufficiently good thermal connections.

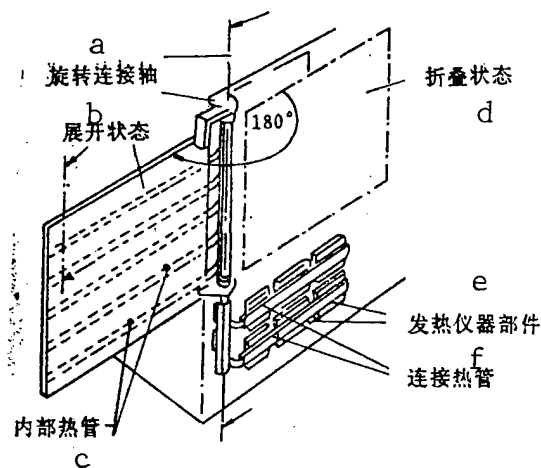

Fig. 4. Schematic diagram of deployable radiator
 KEY: a - rotating connection shaft b - deployed state
 c - inner heat pipe d - folded state e - component
 of heat liberating instrument f - connecting heat pipe

Usually, the east/west panels are unable to be used as heat dissipating surfaces of a three-axis stabilized satellite. If a constant conduction heat pipe is used to connect the east/west panels, the east/west radiators can be added in addition to the south/north radiators, thus becoming a supplementary heat dissipation channel. Within a day, the relative positions of the sun and satellite rotate by 360° ; for the case of the east/west panels, the variation trends of illumination situations and the surface temperatures are just the reverse. By relying on the operation of heat pipes, the east/west radiators can supplement each other for the function of heat dissipating surfaces. As an extreme situation, the east panel is directly illuminated by sunlight, and the west panel is not illuminated at all; it is so, vice versa. The typical heat equilibrium equation is expressed

as follows:

$$0.5\alpha_s \cdot S + q = \sigma \epsilon T^4 \quad (3)$$

As indicated in the calculations, for the east/west radiators connected with a heat pipe, when the waste heat power is approximately 240 to 250W/m², the temperature can be maintained within the range 0 to 40°C.

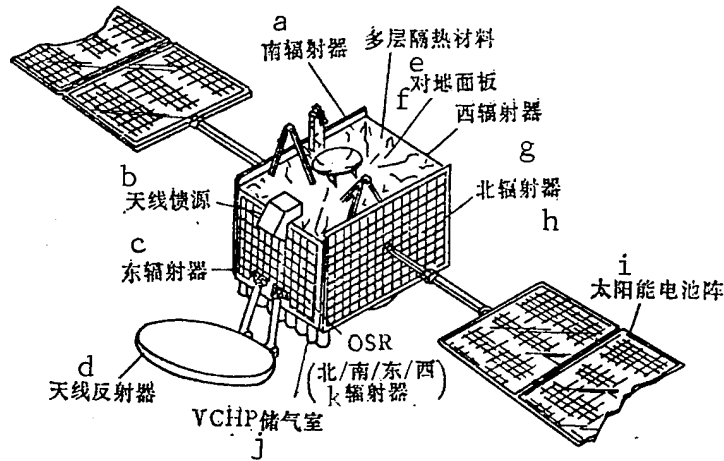

Fig. 5. Schematic diagram of thermal control scheme for communication satellite
 KEY: a - south radiator b - antenna feed source
 c - east radiator d - antenna reflector e - multilayer heat-insulating material f - ground-facing panel
 g - west radiator h - north radiator i - solar cell array j - gas storage chamber k - north/south/east/west radiators

The schemes shown in Figs. 5 and 6 are as follows: a variable-conduction heat pipe connects the ground-facing panel and the east/west panels. The waste heat from instruments and equipment of the ground-facing panel is led to the east/west panels. With diurnal variations in the incident direction of sunlight, the heat dissipation quantity of the east/west

radiators is adjusted, to some extent. For example, when the sunlight directly illuminates the panel with its back to earth, the waste heat of the ground-facing panel will pass through the heat pipe to basically uniformly distribute to the east/west radiators for dissipation into space. When sunlight directly illuminates the west (east) panel, the waste heat of the ground-facing panel will be mainly dissipated through the east (west) radiator.

Of course, whether the south/north panels, or the east/west panels are connected with a heat pipe, general assembly of the satellite will have difficulties, to some extent.

IV. Conclusions

This is an important time requiring further development of thermal control technology in communication satellites. Thermal designers urgently hope to obtain a number of more effective and more reliable thermal control materials and components, to more quickly enhance the precision of thermal analytical computations and ground thermal simulation experiments, promoting to a more advanced level for thermal control subsystems of entire communication satellites.

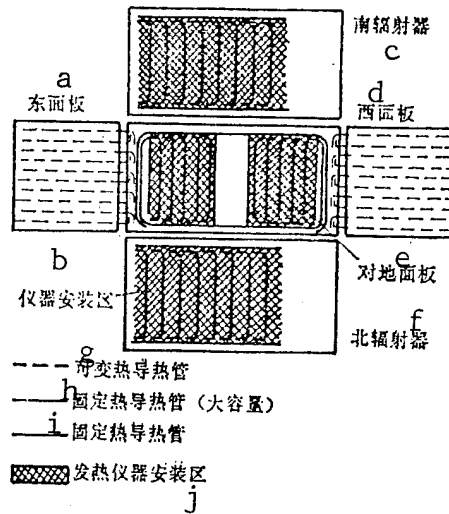

Fig. 6. Schematic diagram for radiator heat pipe layout
 KEY: a - east panel b - instrument installation zone
 c - south radiator d - west panel e - ground-facing
 panel f - north radiator g - variable-conduction
 heat pipe h - constant-conduction heat pipe (large
 capacity) i - constant-conduction heat pipe
 j - installation zone of heat-liberating instruments

The article was received for publication on 5 August 1989.

REFERENCES

- 1 Peter C. Wise, Spacecraft Thermal Control Technology: Design Challenges into the 1990's, IAF-85-373, 1985
- 2 Mitsunobu watanabe, et al, Thermal Design Concept for Large Capacity Communications Satellites, IAF-85-374, 1985
- 3 M.Kitada, et al, Thermal Design and Test of the ETS-V, AIAA 86-1341, 1986
4. Guo Jiurong, "Discussion on Some Problems in Thermal Design of Spin-Stabilized Geostationary Satellites," Zhongguo Kongjian Kexue Jishu [Technology of Space Science in China] IX/2, 58-64 (1989).
- 5 Helmut Kreeb Walter Schwarzott, The Thermal Control System of the German Direct Transmitting Communication Satellite TV-SAT, AIAA80-0503, 1980
- 6 Douglas R. Chalmers, et al, Advanced Communications Satellite Thermal Design Using Variable East/West Radiators, AIAA 86-0065, 1986

DISTRIBUTION LIST

DISTRIBUTION DIRECT TO RECIPIENT

<u>ORGANIZATION</u>	<u>MICROFICHE</u>
B085 DIA/RTS-2FI	1
C509 BALLOC509 BALLISTIC RES LAB	1
C510 R&T LABS/AVEADCOM	1
C513 ARRADCOM	1
C535 AVRADCOM/TSARCOM	1
C539 TRASANA	1
Q592 FSTC	4
Q619 MSIC REDSTONE	1
Q008 NTIC	1
Q043 AFMIC-IS	1
E051 HQ USAF/INET	1
E404 AEDC/DOF	1
E408 AFWL	1
E410 AFDIC/IN	1
E429 SD/IND	1
P005 DOE/ISA/DDI	1
P050 CIA/OCR/ADD/SD	2
1051 AFIT/LDE	1
PO90 NSA/CDB	1
2206 FSL	1

Microfiche Nbr: FTD95C000199

• NAIC-ID(RS) T-0562-93