

RL-TR-94-233
In-House Report
December 1994

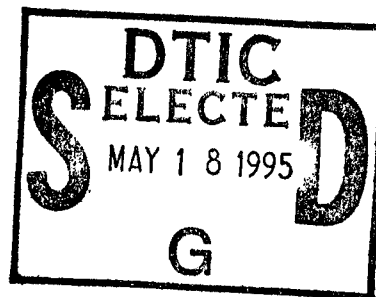

ENVIRONMENTAL STRESS SCREENING PROCESS IMPROVEMENT STUDY

Joseph A. Caroli and Soon Woo



APPROVED FOR PUBLIC RELEASE; DISTRIBUTION UNLIMITED.

19950517 078

DTIC QUALITY INSPECTED 5

Rome Laboratory
Air Force Materiel Command
Griffiss Air Force Base, New York

This report has been reviewed by the Rome Laboratory Public Affairs Office (PA) and is releasable to the National Technical Information Service (NTIS). At NTIS it will be releasable to the general public, including foreign nations.

RL-TR-94-233 has been reviewed and is approved for publication.

APPROVED:

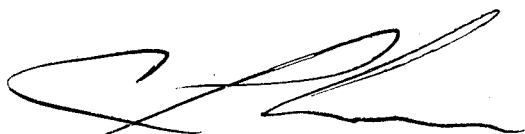

CARMEN J. LUVERA, Chief
Electronics Systems Engineering Division
Electromagnetics & Reliability Directorate

FOR THE COMMANDER:



JOHN J. BART, Chief Scientist
Electromagnetics & Reliability Directorate

If your address has changed or if you wish to be removed from the Rome Laboratory mailing list, or if the addressee is no longer employed by your organization, please notify RL (ERSR) Griffiss AFB NY 13441. This will assist us in maintaining a current mailing list.

Do not return copies of this report unless contractual obligations or notices on a specific document require that it be returned.

REPORT DOCUMENTATION PAGE

Form Approved
OMB No. 0704-0188

Public reporting burden for this collection of information is estimated to average 1 hour per response, including the time for reviewing instructions, searching existing data sources, gathering and maintaining the data needed, and completing and reviewing the collection of information. Send comments regarding this burden estimate or any other aspect of this collection of information, including suggestions for reducing this burden, to Washington Headquarters Services, Directorate for Information Operations and Reports, 1215 Jefferson Davis Highway, Suite 1204, Arlington, VA 22202-4302, and to the Office of Management and Budget, Paperwork Reduction Project (0704-0188), Washington, DC 20503.

1. AGENCY USE ONLY (Leave Blank)		2. REPORT DATE December 1994	3. REPORT TYPE AND DATES COVERED In-House Aug 93 - Aug 94	
4. TITLE AND SUBTITLE ENVIRONMENTAL STRESS SCREENING PROCESS IMPROVEMENT STUDY			5. FUNDING NUMBERS PE - 62702F PR - 2338 TA - 02 WU - 2X	
6. AUTHOR(S) Joseph A. Caroli and Soon Woo				
7. PERFORMING ORGANIZATION NAME(S) AND ADDRESS(ES) Rome Laboratory/ERSR DQAA/ADD 525 Brooks Road 701-600 DAEGU SI DONGDAEGU Griffiss AFB NY 13441-4505 P.O. Box 91 HO South Korea			8. PERFORMING ORGANIZATION REPORT NUMBER RL-TR-94-233	
9. SPONSORING/MONITORING AGENCY NAME(S) AND ADDRESS(ES) Rome Laboratory (ERSR) 525 Brooks Road Griffiss AFB NY 13441-4505			10. SPONSORING/MONITORING AGENCY REPORT NUMBER	
11. SUPPLEMENTARY NOTES Rome Laboratory Project Engineer: Joseph A. Caroli/ERSR (315) 330-4205. This report resulted from the United States/Republic of Korea Engineer and Scientist Exchange Program (US/ROK ESEP).				
12a. DISTRIBUTION/AVAILABILITY STATEMENT Approved for public release; distribution unlimited.			12b. DISTRIBUTION CODE	
13. ABSTRACT (Maximum 200 words) An improved Environmental Stress Screening (ESS) process was developed for electronic equipment. A Process Analysis Technique was used to map the processes documented in five popular ESS guidebooks. A more effective and efficient overall process was then developed by combining the best elements of the individual processes. The five guidebooks studied include: "Tri-Service ESS Guidelines", Mil-Hdbk-344, "ESS of Electronic Equipment", Institute of Environmental Sciences, "ESS Guidelines for Assemblies", TE000-AB-GTP-020A, "ESS Requirements and Application Manual for Navy Electronic Assemblies", and NAVMAT P-9492, "Navy Manufacturing Screening Program". For each guidebook listed above, top level activity flow charts were developed. Inputs and outputs for each activity are illustrated and explained. This provided an explicit set of clearly defined processes that were then studied and improved upon. The process description approach has several advantages. It enables improvement of the individual ESS processes, or as explained above, generation of a grand, optimized process. It provides a tool to aid in understanding the ESS discipline. It also provides a baseline for automation. This report was co-authored by United States and South Korean engineers working together under the auspices of the United States/Republic of Korea Engineer and (continued)				
14. SUBJECT TERMS Environmental Stress Screening, Process Improvement			15. NUMBER OF PAGES 130	
			16. PRICE CODE	
17. SECURITY CLASSIFICATION OF REPORT UNCLASSIFIED	18. SECURITY CLASSIFICATION OF THIS PAGE UNCLASSIFIED	19. SECURITY CLASSIFICATION OF ABSTRACT UNCLASSIFIED	20. LIMITATION OF ABSTRACT U/L	

Block 13 (Continued)

Scientist Exchange Program (US/ROK ESEP).

Accession For	
NTIS CRA&I	<input checked="" type="checkbox"/>
DTIC TAB	<input type="checkbox"/>
Unannounced	<input type="checkbox"/>
Justification	
By	
Distribution /	
Availability Codes	
Dist	Avail and/or Special
A-1	

Table of Contents

	<u>Page</u>
List of Figures.....	ii
1.0 Introduction.....	1-1
Glossary of ESS Terms.....	1-5
Abbreviations.....	1-8
2.0 ESS Process Improvement.....	2-1
3.0 ESS Guidebook Process Descriptions.....	3-1
3.1 Institute of Environmental Sciences (IES) ESS Guidelines for Assemblies.....	3-1
3.1.1 Discussion of IES ESS Guidelines for Assemblies.....	3-1
3.1.2 IES ESS Guidelines Process.....	3-1
3.2 Tri-Service ESS Guidelines.....	3-15
3.2.1 Discussion of Tri-Service ESS Guidelines....	3-15
3.2.2 Tri-Service ESS Guidelines Process.....	3-15
3.3 Navy Manufacturing Screening Program.....	3-28
3.3.1 Discussion of Navy Manufacturing Screening Program.....	3-28
3.3.2 Navy Manufacturing Screening Program Process	3-28
3.4 Mil-Hdbk-344A, ESS of Electronic Equipment.....	3-32
3.4.1 Discussion of Mil-Hdbk-344A.....	3-32
3.4.2 Mil-Hdbk-344A Process.....	3-32
3.5 TE000-AB-GTP-020A, ESS Requirements and Application Manual for Navy Electronic Equipment.....	3-46
3.5.1 Discussion of TE000-AB-GTP-020A.....	3-46
3.5.2 TE000-AB-GTP-020A Process.....	3-46
3.6 Summary of Other Equipment/Assembly Level ESS Guidebooks.....	3-52
4.0 Summary and Recommendations.....	4-1
4.1 Summary.....	4-1
4.2 Recommendations.....	4-1
Appendix A, An Improved/Easier to Use Mil-Hdbk-344A Calculation Procedure.....	A-1
Appendix B, Bibliography.....	B-1

List of Figures

	<u>Page</u>
Figure 1.1	Process Analysis Technique Used to Define and Document ESS Processes..... 1-2
Figure 1.2	Merging the Processes to Define a "Grand/Optimized" ESS Process..... 1-3
Figure 2.1	General ESS Process Flow Diagram..... 2-1
Figure 2.2	Improved Classical ESS Process..... 2-2
Figure 2.3	Improved Quantitative ESS Process..... 2-3
Figure 2.4	Activity C1.0: Preparation of ESS Plans..... 2-4
Figure 2.5	Activity C2.0: Assurance of Incoming Parts Quality Levels..... 2-6
Figure 2.6	Activity C3.0: Additional Parts Screening (Rescreening)..... 2-7
Figure 2.7	Activity C4.0: Identify Nature of Anticipated Defects..... 2-8
Figure 2.8	Activity C5.0: Determination of ESS Levels of Assembly..... 2-9
Figure 2.9	Activity C6.0: Development of RV and TC Starting Regimens..... 2-10
Figure 2.10	Activity C6A.0: Development of RV Starting Regimen..... 2-11
Figure 2.11	Activity C6B.0: Development of TC Starting Regimen..... 2-13
Figure 2.12	Activity C7.0: Initial Production Screening.. 2-14
Figure 2.13	Activity C8.0: Optimize/Finalize Initial ESS Profiles & Placement..... 2-15
Figure 2.14	Activity C9.0: Production Screening..... 2-16
Figure 2.15	Activity C10.0: Fallout Analysis..... 2-17
Figure 2.16	Activity C11.0: Quantitative Tailoring of ESS 2-18
Figure 2.17	Activity C12.0: ESS Process Control..... 2-19
Figure 2.18	Activity C13.0: Cost-Benefit Analysis..... 2-20

Figure 2.19	Activity C14.0: Modification of Screens as Necessary.....	2-21
Figure 2.20	Activity C15.0: Decision to go from 100% ESS to Sampling.....	2-22
Figure 2.21	Activity C16.0: PRVT and Final Acceptance Test.....	2-23
Figure 2.22	Activity C17.0: Implementation of FRACAS.....	2-24
Figure 2.23	Activity C18.0: Continuous Improvement of Design, Manufacturing and Test Processes.....	2-25
Figure 2.24	Activity C19.0: Fielded System.....	2-26
Figure 2.25	Activity Q5.0: Establishing ESS Objectives & Goals.....	2-27
Figure 2.26A	Activity Q6A.0: Generate Initial Estimates of Defect Density.....	2-28
Figure 2.26B	Activity Q6B.0: Refine Estimates of Defect Density.....	2-29
Figure 2.27	Activity Q7.0: Screen Selection and Placement	2-30
Figure 2.28A	Activity Q8A.0: Generate Initial Estimates of Screen Strength.....	2-32
Figure 2.28B	Activity Q8B.0: Refine Estimates of Screen Strength.....	2-33
Figure 2.29	Activity Q9.0: Fatigue-Life Estimate.....	2-34
Figure 2.30	Activity Q10.0: Cost Analysis.....	2-35
Figure 2.31	Activity Q11.0: Optimization.....	2-36
Figure 2.32	Activity Q12.0: Preparation to Implement ESS.	2-37
Figure 2.33	Activity Q14.0: Fallout Analysis.....	2-38
Figure 2.34	Activity Q15.0: Monitor and Control.....	2-39
Figure 3.1	Institute of Environmental Sciences ESS Guidelines Top Level Activities Flow Diagram.	3-2
Figure 3.2	Activity IES.1: Preparation of ESS Plans.....	3-3
Figure 3.3	Activity IES.2: Determination of ESS Levels of Assembly.....	3-4

Figure 3.4	Activity IES.3: Development of RV and TC Starting Regimens.....	3-5
Figure 3.5	Activity IES.3A: Development of RV Starting Regimen.....	3-6
Figure 3.6	Activity IES.3B: Development of TC Starting Regimen.....	3-7
Figure 3.7	Activity IES.4: Production Screening.....	3-8
Figure 3.8	Activity IES.5: Fallout Analysis.....	3-9
Figure 3.9	Activity IES.6: Cost-Benefit Analysis.....	3-10
Figure 3.10	Activity IES.7: Quantitative Tailoring of ESS	3-11
Figure 3.11	Activity IES.8: ESS Process Control.....	3-12
Figure 3.12	Activity IES.9: Modification of Screens as Necessary.....	3-13
Figure 3.13	Activity IES.10: Final Acceptance Test.....	3-14
Figure 3.14	Tri-Service ESS Guidelines Top Level Activities Flow Diagram.....	3-16
Figure 3.15	Activity TS.1: Preparation of ESS Plans.....	3-17
Figure 3.16	Activity TS.2: Identify Nature of Anticipated Defects.....	3-18
Figure 3.17	Activity TS.3: Determine Appropriate Initial Profile & Placement by Experimentation.....	3-19
Figure 3.18	Activity TS.4: Initial Production Screening..	3-20
Figure 3.19	Activity TS.5: Optimize/Finalize ESS Profiles & Placement.....	3-21
Figure 3.20	Activity TS.6: Implementation of FRACAS.....	3-22
Figure 3.21	Activity TS.7: Documentation of ESS Details..	3-23
Figure 3.22	Activity TS.8: Production Screening.....	3-24
Figure 3.23	Activity TS.9: Fallout Analysis.....	3-25
Figure 3.24	Activity TS.10: Decision to go from 100% ESS to Sampling.....	3-26
Figure 3.25	Activity TS.11: Continuous Improvement of Design, Manufacturing and Test Processes.....	3-27

Figure 3.26	Navy Manufacturing Screening Program Top Level Activities Flow Diagram.....	3-28
Figure 3.27	Activity NAV.1: Random Vibration Screening...	3-29
Figure 3.28	Activity NAV.2: Temperature Cycling Screening	3-30
Figure 3.29	Mil-Hdbk-344 Top Level Activities Flow Diagram.....	3-33
Figure 3.30	Activity 344.1: Preparation of ESS Plans.....	3-34
Figure 3.31	Activity 344.2: Establishing ESS Objectives & Goals.....	3-35
Figure 3.32A	Activity 344.3A: Generate Initial Estimates of Defect Density.....	3-36
Figure 3.32B	Activity 344.3B: Refine Estimates of Defect Density.....	3-37
Figure 3.33	Activity 344.4: Screen Selection and Placement.....	3-38
Figure 3.34A	Activity 344.5A: Generate Initial Estimates of Defect Density.....	3-39
Figure 3.34B	Activity 344.5B: Refine Estimates of Screen Strength.....	3-40
Figure 3.35	Activity 344.6: Cost Analysis.....	3-41
Figure 3.36	Activity 344.7: Optimization for Cost.....	3-42
Figure 3.37	Activity 344.8: Fallout Analysis.....	3-43
Figure 3.38	Activity 344.9: Monitor and Control.....	3-44
Figure 3.39	Activity 344.10: Product Reliability Verification Test.....	3-45
Figure 3.40	TE000-AB-GTP-020A Top Level Activities Flow Diagram.....	3-46
Figure 3.41	Activity TE.1: Assurance of Incoming Screened Parts Quality Levels.....	3-47
Figure 3.42	Activity TE.2: Additional Parts Screening (Rescreening).....	3-48
Figure 3.43	Activity TE.3: PWA Temperature Cycling ESS...	3-49
Figure 3.44	Activity TE.4: PWA or Higher Indenture Level Random Vibration.....	3-50

Figure 3.45	Activity TE.5: Higher Indenture Level Temperature Cycling ESS.....	3-51
Figure A.1	Quantitative ESS Calculation Flow Chart.....	A-2
Table A-1	Mil-Hdbk-344A Parameter Computations.....	A-4

1.0 Introduction

This report was jointly written by engineers from the United States (US) and the Republic of Korea (ROK) under the auspices of the US/ROK Engineer and Scientist Exchange Program. The study objective was to generate an improved assembly level environmental stress screening (ESS) process through a detailed analysis and evaluation of the many existing ESS guidebooks. A process analysis technique (PAT) was used to map the processes depicted in the guidebooks. An improved process was then defined and documented using the same PAT.

Environmental stress screening involves the removal of latent part and manufacturing process defects through the application of environmental stimuli such as random vibration and thermal cycling while the equipment is still in the factory. By exposing equipment to predetermined levels of stress, latent defects are precipitated in the factory precluding their occurrence as failures in the field. As defects are precipitated, root causes should be determined and design and manufacturing processes improved. Several guidebooks have been developed to aid in setting effective ESS screening levels and to lend engineering and program management guidance for implementation. The following is a list of thirteen equipment/assembly level ESS guidance documents that were investigated for this effort.

- Tri-Service Environmental Stress Screening Guidelines
- Mil-Hdbk-344, "Environmental Stress Screening of Electronic Equipment"
- Institute of Environmental Sciences, "Environmental Stress Screening Guidelines for Assemblies"
- NAVMAT P-9492, "Navy Manufacturing Screening Program"
- TE000-AB-GTP-020A, "Environmental Stress Screening Requirements and Application Manual for Navy Electronic Assemblies"
- AFP 800-7, "USAF R&M 2000 Process"
- AMC-R 702-25, "Army Materiel Command Environmental Stress Screening Program"
- DOD 4245.7-M, "Transition From Development to Production" (with companion document - NAVSO P-6071, "Best Practices")
- Mil-Hdbk-338, "Electronic Reliability Design Handbook"
- Mil-Std-781, "Reliability Testing for Engineering Development, Qualification, and Production"(with companion document Mil-Hdbk-781, "Reliability Test Methods, Plans, and Environments for Engineering Development, Qualification, and Production")

- Mil-Std-2164, "Environmental Stress Screening Process for Electronic Equipment"
- Sacramento Air Logistics Center Environmental Stress Screening Handbook
- Warner Robbins Air Logistics Center Environmental Stress Screening Handbook

Of the thirteen documents listed, the first five were studied in detail and documented in formal process descriptions. The improved process description was generated based on the combination of the five studies. A process analysis technique which is a modification of the Xerox Product Delivery Process technique was used to define and document the five processes as well as the improved process. The process analysis technique consists of a top level activities flow diagram, individual activity flow diagrams, and a detailed discussion of each activity and all inputs and outputs to the activities. The procedure as used within this report is illustrated in Figure 1.1.

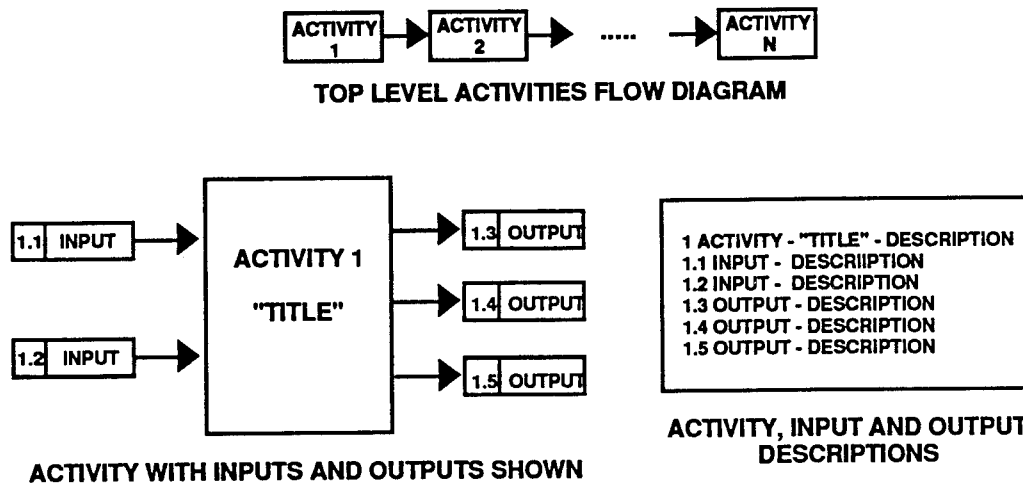

Figure 1.1. Process Analysis Technique Used to Define and Document ESS Processes

Focusing on ESS from a process perspective has several advantages. Advantages include: 1.) Providing a valuable educational tool. This report could be used to educate an engineer or manager with little or no understanding of ESS. 2.) Providing flexibility to tailor and structure well defined ESS programs. 3.) Forming a basis for automation. An automated ESS tool is a logical follow-on to this study. 4.) Continuous improvement of ESS approaches. Improvement could take place individually on the ESS guidebook methodologies studied. For the purpose of this effort, a "process merging" and improvement exercise was accomplished to generate a grand ESS process. Using the format documented in this report, improvement could continue indefinitely, striving for perfection of the ESS process.

Value added activities and sub activities were extracted from the individual ESS processes and combined to form the improved and optimized process. Figure 1.2 illustrates how this concept was implemented.

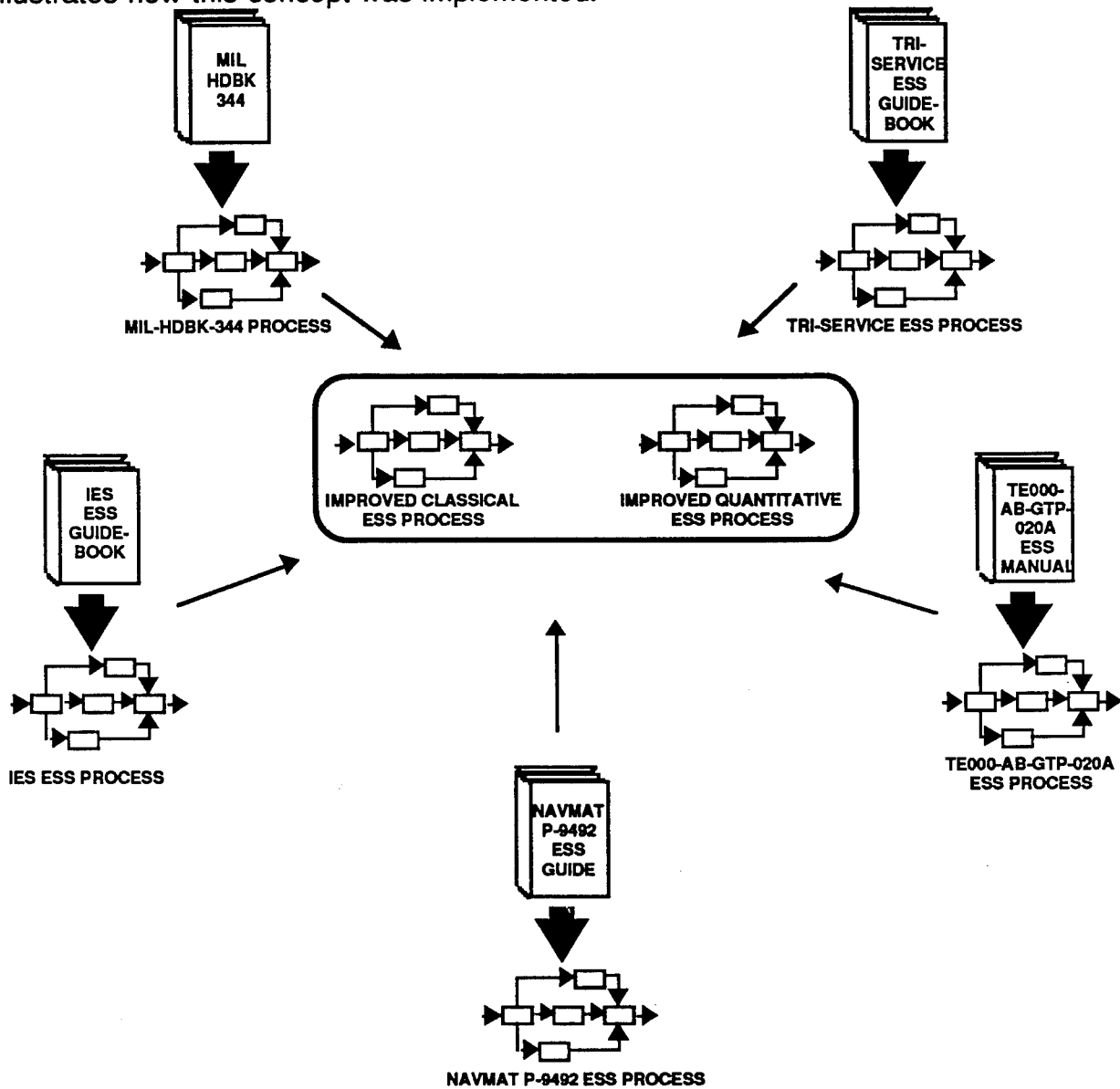

Figure 1.2. Merging the Processes to Define a "Grand/Optimized" ESS Process

There are two general approaches to ESS, this report designates the two as "classical" and "quantitative". The differences between the two lie in how initial goals are set, how random vibration and temperature cycling regimens are developed and modified, and how monitoring and tracking of precipitated defects are accomplished. With "classical" screening, the government either explicitly specifies the screens and screening parameters to be used or the contractor is given the freedom to propose a screening program which is tailored to the product and is subject to government approval. The "classical" approach often involves determining ESS requirements for each level of assembly and then designing each screen using available methods.

Some of the methods include flaw precipitation threshold, internal response levels, step-stress tests, fault replication tests, heritage screens and surveys. The "quantitative" approach to ESS focuses on the defects which remain in the product at delivery and their impact on field reliability. The use of a "quantitative" approach requires that the initial part latent defect levels, the defect level introduced during manufacture of the product, the effectiveness of the screens, and acceptable values for the latent defect content (which remains and escapes into the field) are all addressed when setting up screening regimens. Improved processes were defined for both approaches. The two approaches do have many similarities.

Chapter 2 of this report provides a detailed description of the improved ESS process(es). ESS practitioners can use the information to help implement their programs. The format and content could also be used to continuously improve ESS and to develop an automated ESS tool. Automation of the processes is desirable and should be explored as a follow-on to this effort. Chapter 3 contains individual process descriptions of the 5 guidebooks studied. This section can be used to help implement and improve upon each process individually. Chapter 4 is a summary of the report with recommendations for further research. Appendix A documents an improved and easier to use calculation procedure for the quantitative ESS methodology of Mil-Hdbk-344A.

Glossary of ESS Terms

Axes of Excitation - The number of axes of vibration applied during vibration screening.

Classical ESS - ESS where screening levels are not determined and continuously modified through quantitative means such as those found in Mil-Hdbk-344.

Defect: Latent Defect - An inherent or induced weakness, not detectable by ordinary means, which will either be precipitated to early failure under environmental stress screening conditions or eventually fail in the intended use environment.

Patent Defect - An inherent or induced weakness which can be detected by inspection, functional test, or other defined means.

Defect Density - The average number of defects per item.

Detection Efficiency - A measure of the capability of detecting a patent defect.

Environmental Stress Screening (ESS) - A process or series of processes in which environmental stimuli, such as rapid thermal cycling and random vibration, are applied to electronic items in order to precipitate latent defects to early failure.

Failure-Free Period - A contiguous period of time during which an item is to operate without the occurrence of a failure while under environmental stress.

Fallout - Failures observed during, or immediately after, and attributed to stress screens.

Fallout Analysis - The study of fallout failures for the purpose of modifying screens.

Fault Replication Test Method - A method used to generate a satisfactory initial vibration screening level by gradually increasing the stress level until previously known faults are precipitated.

Final Acceptance Test - The environmental test used to validate that customer mean time between failure or failure-free requirements have been achieved. Final acceptance test is usually conducted after ESS.

Fixture - The apparatus used to mount the electronic equipment on the vibrator/shaker machine.

Flaw Precipitation Threshold Method - A method used to generate a satisfactory initial vibration screening level by performing a vibration survey and then performing detailed computations on the global responses within the test specimen. This method is also referred to as the "Tailored Spectral Response" method.

Functional Test Program - Procedures associated with testing the functionality of electronic equipment.

Heritage Screen Method - A method used to generate satisfactory initial screening levels by studying results of screening experience on similar equipment. This method is used for both vibration and thermal screening.

Mounting Scheme - The method used to affix the equipment to the shaker/vibrator.

Overall Internal Response Level Method - A method used to generate a satisfactory initial vibration screening level by performing a vibration survey and then performing simplified versions of the computations used for the flaw precipitation threshold method.

PARETO Chart - A bar chart used to highlight the few major contributors to problems vs. the trivial many contributors. The PARETO chart is based on the PARETO principle which states that 20 percent of the problems have 80 percent of the impact.

Precipitation (of Defects) - The process of transforming a latent defect into a patent defect.

Precipitation Efficiency - A measure of the capability of a screen to precipitate latent defects to failure.

Power Spectral Density - A unit of measure for random vibration. A random vibration spectrum is usually shown graphically as power spectral density in g^2/Hz on the ordinate and frequency in Hz on the abscissa.

Product Reliability Verification Test (PRVT) - A test to provide confidence that field reliability will be achieved. PRVT is a segment of the ESS program implemented primarily when ESS has been nearly eliminated through corrective actions that have reduced the incoming defect densities for parts and manufacturing.

Quantitative ESS - ESS where screening parameters are determined based on models and equations which relate required reliability to allowable remaining defect content. Such a method is outline in Mil-Hdbk-344.

Random Vibration ESS- The excitation of equipment with continuously changing frequency and peak acceleration. The equipment is exposed to a wide frequency range.

Rescreening: Incoming Parts Rescreening - The process of applying environmental stress screening to microcircuits, semiconductors and discrete parts at the point of receiving them from a supplier. **Repaired Equipment Rescreening** The process of screening equipment after the equipment failed as a result of ESS and was repaired back to a functional state.

Screening Regimen (or Screening Profile) - A combination of stress screens applied to an equipment, identified in the order of application (i.e., assembly, unit and system screens).

Screening Strength - The probability that a specific screen will precipitate a latent defect to failure and detect it by test, given that a latent defect susceptible to the screen is present. It is the product of precipitation efficiency and detection efficiency.

Step Stress Method - A method used to generate a satisfactory initial vibration screening level by incrementally increasing the vibration stress level until the tolerance limit is found. The tolerance limit is then used to determine the screening level.

Temperature Cycling (or Thermal Cycling) ESS - A method of ESS where equipment is exposed to high and low temperature cycling. A temperature cycling profile consists of temperature range, temperature rate of change, temperature dwell duration, number of cycles, and equipment condition (i.e., power on or off, equipment monitored or not, etc.).

Thermal Chamber- A cabinet in which hardware is placed in order to apply thermal stress to it.

Thermal Survey - The measurement of thermal response characteristics at points of interest within an equipment when temperature extremes are applied to the equipment.

Vibration Survey - The measurement of vibration response characteristics at points of interest within an equipment when vibration excitation is applied to the equipment.

Vibrator or (Electrodynamic Shaker) - A unit which an electronic equipment is attached to for conducting vibration ESS.

Yield - The probability that an equipment will pass a screen or test without failure.

Abbreviations

CFR - constant failure rate

D - damage index

dB - decibel

DL - damage index for product life

DE - damage index for environmental stress screening

DE - detection efficiency

DIN - incoming defect density

DLAT - latent defect density

DPAT - patent defect density

DREMAINING - remaining defect density

ESS - environmental stress screening

FRACAS - failure reporting and corrective action system

g - acceleration due to gravity

g^2/Hz - power spectral density

Hz - hertz

IES - Institute of Environmental Sciences

IES ESSEH - Institute of Environmental Sciences environmental stress screening of electronic hardware committee

k - stress constant

MTBF - mean time between failure

PAT - process analysis technique

PE - precipitation efficiency

PRVT - product reliability verification test

PWA - printed wiring assembly

QML- qualified manufacturers list

R&M - reliability and maintainability

RMS - root mean square

RV - random vibration

SAF - stress adjustment factor

SOW - statement of work

SPC - statistical process control

TC - temperature cycling or thermal cycling

TDP - technical data package

US/ROK ESEP - United States/Republic of Korea Engineer and Scientist Exchange Program

2.0 ESS Process Improvement

In order to develop an overall improved/optimized ESS process, it was necessary to study the various philosophies outlined in the guidance documents, depict them as individual processes, and then structure the optimized/improved process. As discussed in chapter 1 there are two philosophical approaches to ESS: 1. A quantitative approach such as that outlined in Mil-Hdbk-344, and 2. The classical approach based on surveys and other experimental screening. On the basis of this fact, it was necessary to develop an optimized process for each style or approach. The two styles do have some common activities as can be seen from the General ESS Process Flow Diagram shown in Figure 2.1 below.

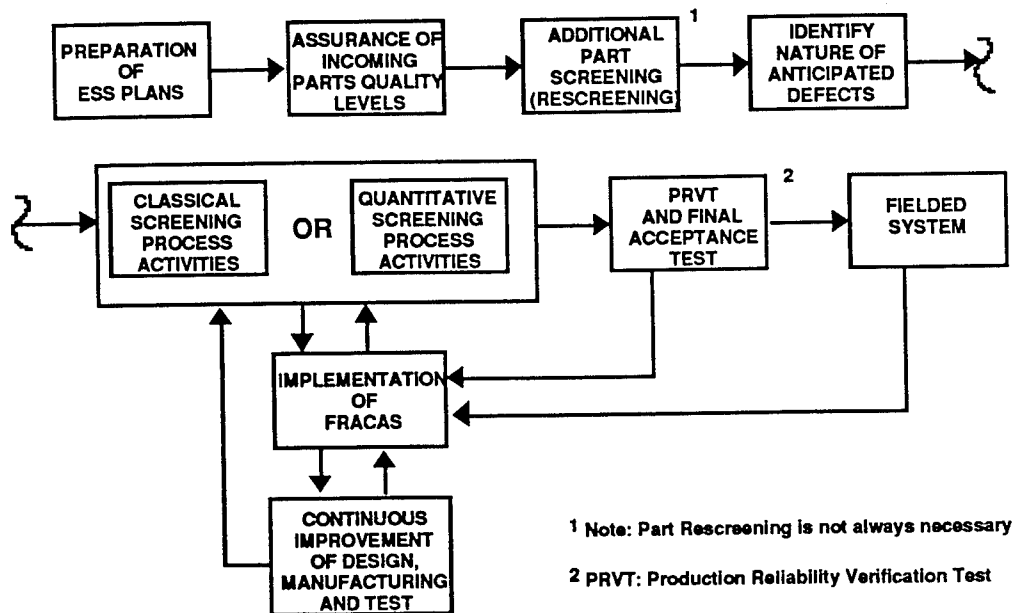

Figure 2.1. General ESS Process Flow Diagram

The Improved Classical Screening Process

Figure 2.2 illustrates the top level activities flow diagram for the improved classical screening process. Activities are numbered C1 through C19 where the "C" represents "Classical". Figures 2.4 through 2.24 show the activity flow diagrams with inputs and outputs. The descriptions of the activities, inputs and outputs follow each activity flow diagram.

The Improved Quantitative Screening Process

Figure 2.3 illustrates the top level activities flow diagram for the improved quantitative screening process. The eight activities shown in figure 2.1 above are the same for both the classical and quantitative processes, therefore detailed activity descriptions are not repeated for the quantitative process. Activities are numbered Q1 through Q19 where the "Q" represents "Quantitative". Figures 2.25 through 2.38 show the activity flow diagrams with inputs and outputs. The descriptions of the activities, inputs and outputs follow each activity flow diagram.

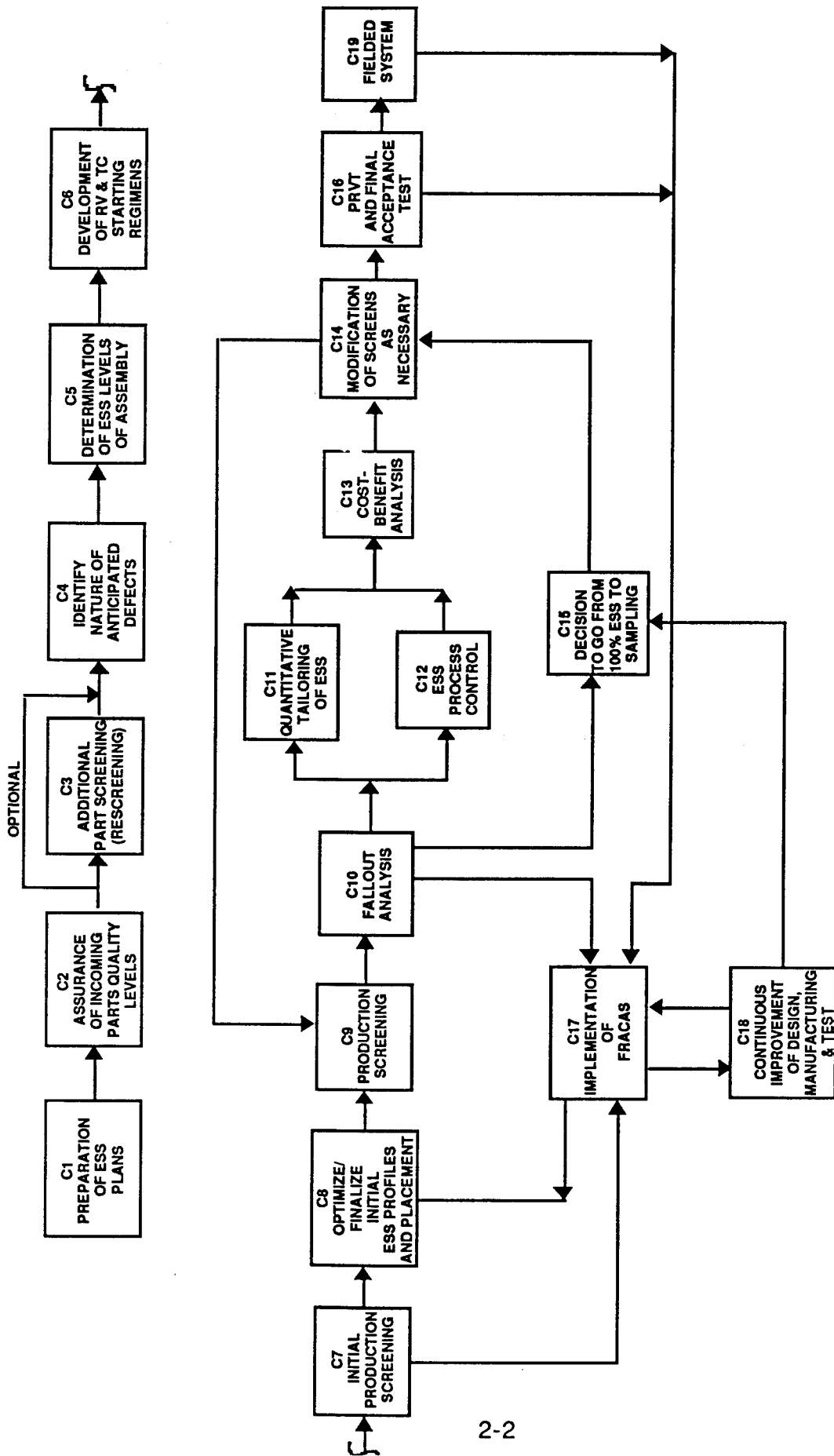

Figure 2.2. Improved Classical Environmental Stress Screening Process

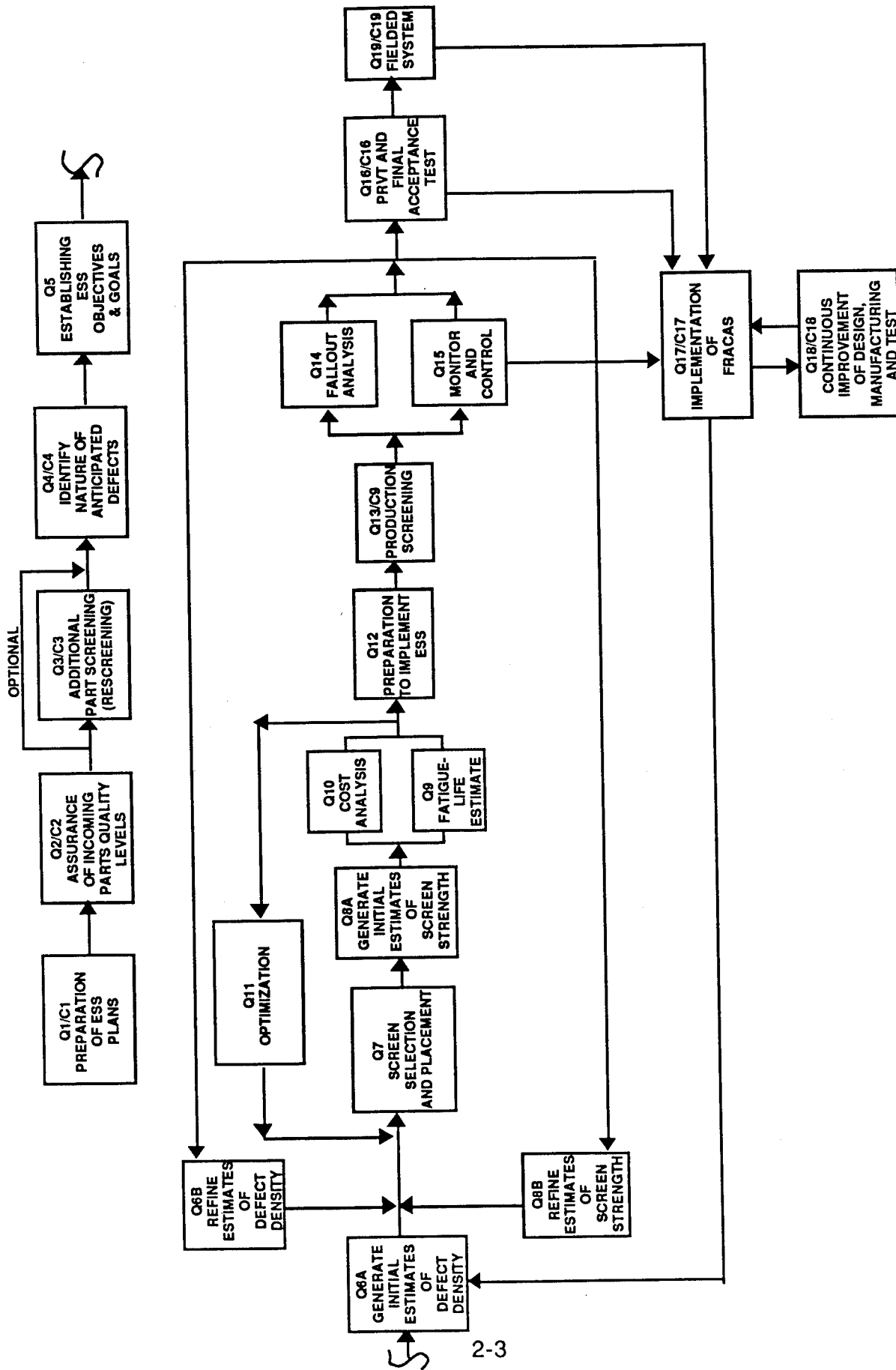

Figure 2.3. Improved Quantitative Environmental Stress Screening Process

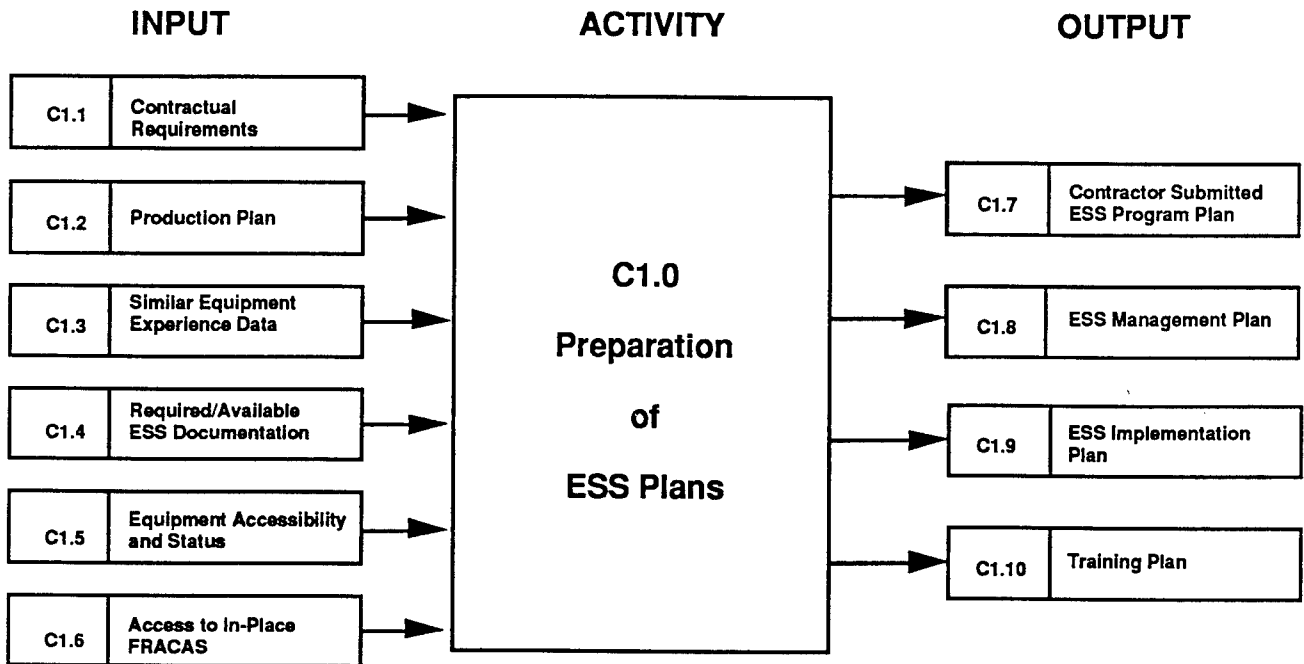

Figure 2.4. Activity C1.0: Preparation of ESS Plans

C1.0 ACTIVITY - Preparation of ESS Plans

Plan preparation is the first step required for any sound ESS program. This activity was generated by combining all value added elements concerned with plan preparation from the guidebooks studied.

C1.1 INPUT - Contractual Requirements

ESS plans must focus on ways to satisfy customer specified contractual requirements. Requirements are usually documented in the customer generated statement of work (SOW).

C1.2 INPUT - Production Plan

This includes information relative to the quantity of items being manufactured, the master production schedule, etc.

C1.3 INPUT - Similar Equipment Experience Data

This can be data from the failure reporting and corrective action system (FRACAS) of identical or similar equipment. It can originate from the field, ESS or other test. The data are useful to estimate the type and quantity of defects likely to be present in the hardware.

C1.4 INPUT - Required/Available ESS Documentation

All documentation should be gathered including available ESS guidebooks, military handbooks or standards, technical reports, procedures, etc. The technical data package (TDP) of the equipment which usually includes specifications, drawings, part histories, assembly procedures, test procedures, etc. Any available software to help automate the ESS process will also be useful.

C1.5 INPUT - Equipment Accessibility and Status

Available screening equipment vs. equipment requirements should be realized during the ESS planning phase.

C1.6 INPUT - Access to In-Place FRACAS

The organization should have an in-place operational FRACAS. The FRACAS system should be made available to the ESS personnel. As illustrated in figures 2.1, 2.2 and 2.3 ESS gets into the FRACAS loop by reporting failures after fallout analysis from production screening. FRACAS data is used by ESS personnel to help optimize ESS profiles and to generate estimates of defect density.

C1.7 OUTPUT - Contractor Submitted ESS Program Plan

The contractor should submit a program plan to document planned ESS methods and procedures. The plan should include a description of all planned activities found in both the management and implementation plans.

C1.8 OUTPUT - ESS Management Plan

This should include as a minimum the following: a checklist of ESS activities planned for each life cycle phase, the planned ESS process flow, criteria for going from 100% ESS to sampling, data collection plans, analysis and management methods relative to the FRACAS, list of available TDP related to ESS and equipment, selection criteria for random vibration (RV) and temperature cycling (TC) screen selections ; description of subcontractor and supplier ESS to be performed, and decision criteria for parts rescreening.

C1.9 OUTPUT - ESS Implementation Plan

This should include as a minimum the following: master schedule of planned ESS activities, acquisition plan for ESS test equipment and accessories (vibration plan, chamber, fixtures, required tooling), available/required TDP, existing ESS procedures and documentation.

C1.10 OUTPUT - ESS Training Plan

Those responsible for management of ESS should assure that all personnel involved are properly trained and that any voids are filled through formal training.

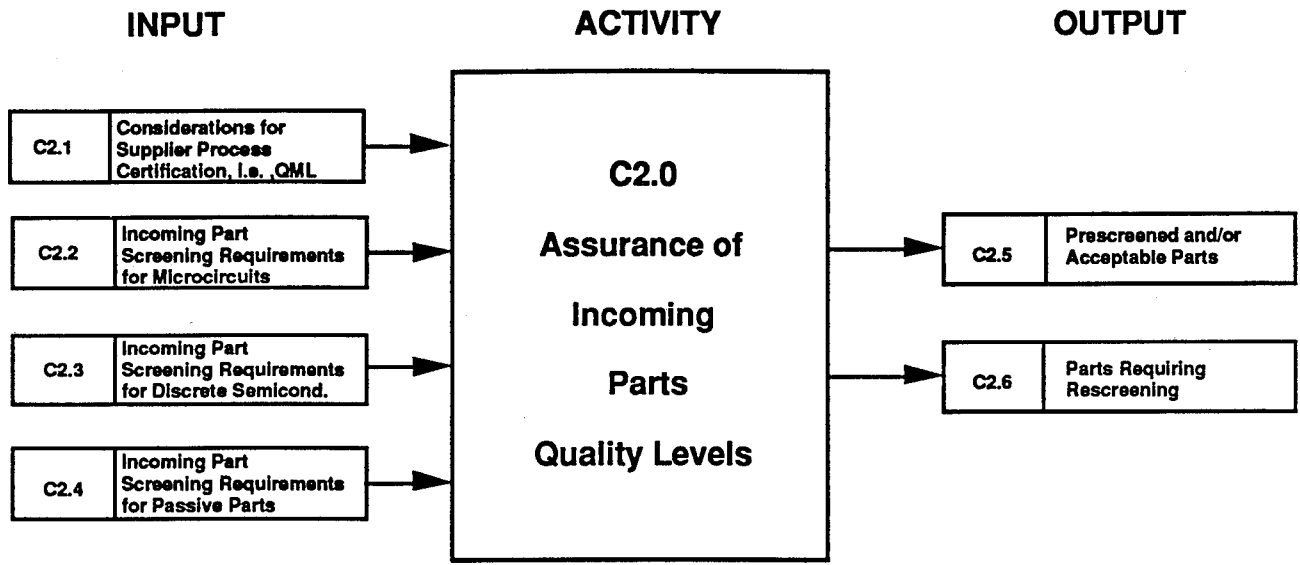

Figure 2.5. Activity C2.0: Assurance of Incoming Parts Quality Levels

C2.0 ACTIVITY - Assurance of Incoming Parts Quality Levels

This activity involves assuring that incoming parts meet minimum acceptable quality requirements either through rescreening or supplier certification/control.

C2.1 INPUT - Considerations for Supplier Process Certification, i.e., QML
 Cooperative customer/supplier relationships should be sought. The qualified manufacturers list (QML) program involves the certification of a suppliers manufacturing process as opposed to individual product certification. Qualified/trusted suppliers should be attained when possible and a system of customer/supplier partnership should be developed as opposed to the classical adversarial relationship.

C2.2 INPUT - Incoming Part Screening Requirements for Microcircuits
 This includes minimum acceptable criteria for microcircuits. The criteria could be in the form of either minimum/certified test exposure or proof of a minimum defect density level.

C2.3 INPUT - Incoming Part Screening Requirements for Discrete Semiconductors
 This includes minimum acceptable criteria for discrete semiconductors. The criteria could be in the form of either minimum/certified test exposure or proof of a minimum defect density level.

C2.4 INPUT - Incoming Part Screening Requirements for Passive Parts
 This includes minimum acceptable criteria for passive parts. The criteria could be in the form of either minimum/certified test exposure or proof of a minimum defect density level.

C2.5 OUTPUT - Prescreened and/or Acceptable Parts
 This includes all received parts that have met minimum acceptable criteria.

C2.6 OUTPUT - Parts Requiring Rescreening

This includes all received parts that have not met minimum acceptable criteria and must therefore be rescreened.

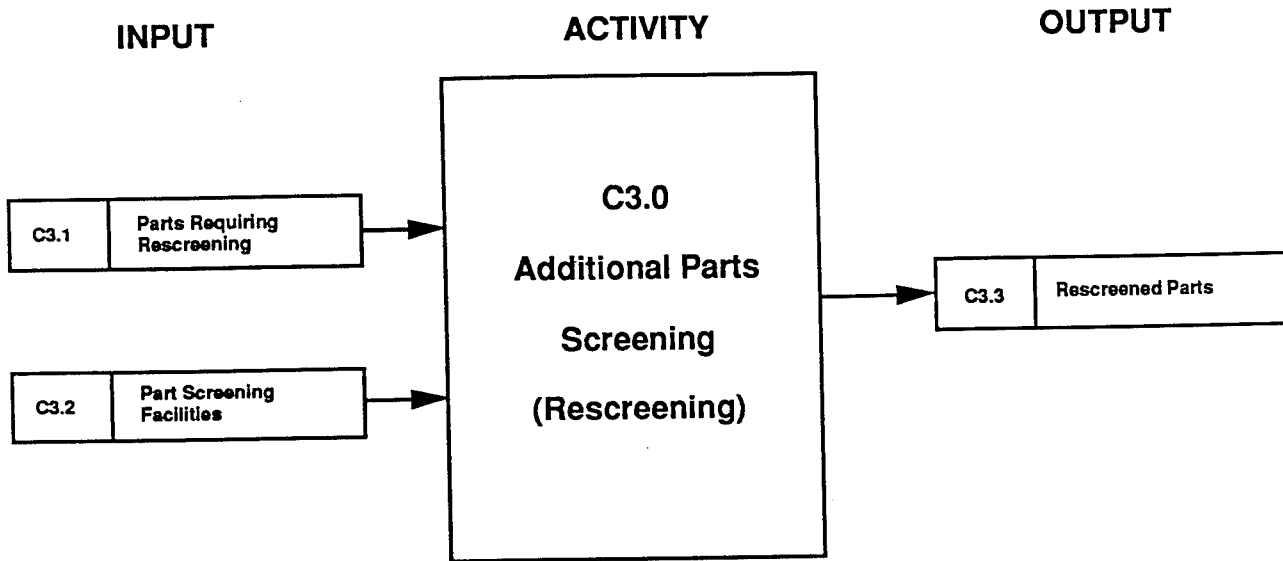

Figure 2.6. Activity C3.0: Additional Parts Screening (Rescreening)

C3.0 ACTIVITY - Additional Parts Screening (Rescreening)

This activity involves screening of all incoming/supplier parts that require rescreening. Rescreening isn't always necessary, it is determined on a case by case basis.

C3.1 INPUT - Parts Requiring Rescreening

All those parts not meeting minimum acceptable criteria as discussed above in activity 2.0. This is the same as output C2.6.

C3.2 INPUT - Part Screening Facilities

Screening and test equipment and any other associated facilities or equipment used for part screening.

C3.3 OUTPUT - Rescreened Parts

Those parts which have undergone rescreening.

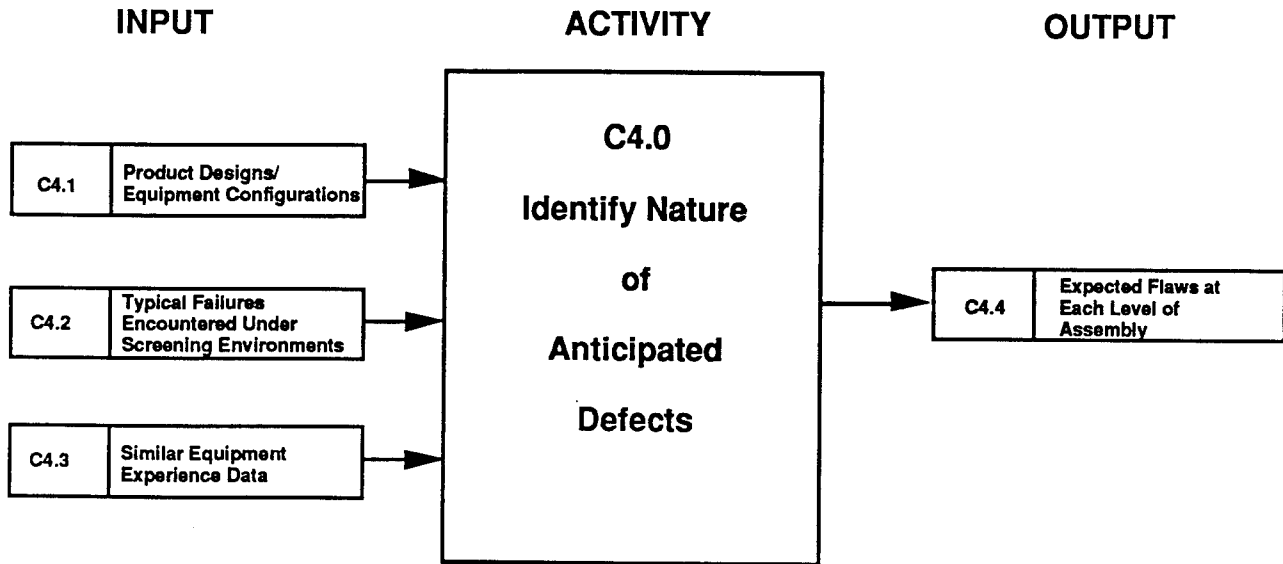

Figure 2.7. Activity C4.0: Identify Nature of Anticipated Defects

C4.0 ACTIVITY - Identify Nature of Anticipated Defects

This activity involves studying the equipment and determining the typical flaws expected to be precipitated through ESS.

C4.1 INPUT - Product Designs/Equipment Configuration

The equipment makeup is necessary for determining the nature of anticipated defects that will be precipitated.

C4.2 INPUT - Typical Failure Encountered Under Screening Environments

Tables are provided in most of the ESS guidebooks that give examples of various types of defects that are generally precipitated through thermal cycling, vibration, or both.

C4.3 INPUT - Similar Equipment Experience Data

This is the same as input C1.3 above.

C4.4 OUTPUT - Expected Flaws at Each Level of Assembly

This information is necessary in order to help select the appropriate ESS environments and levels of assembly. ESS personnel should be aware of the defect types that are likely to be screened out.

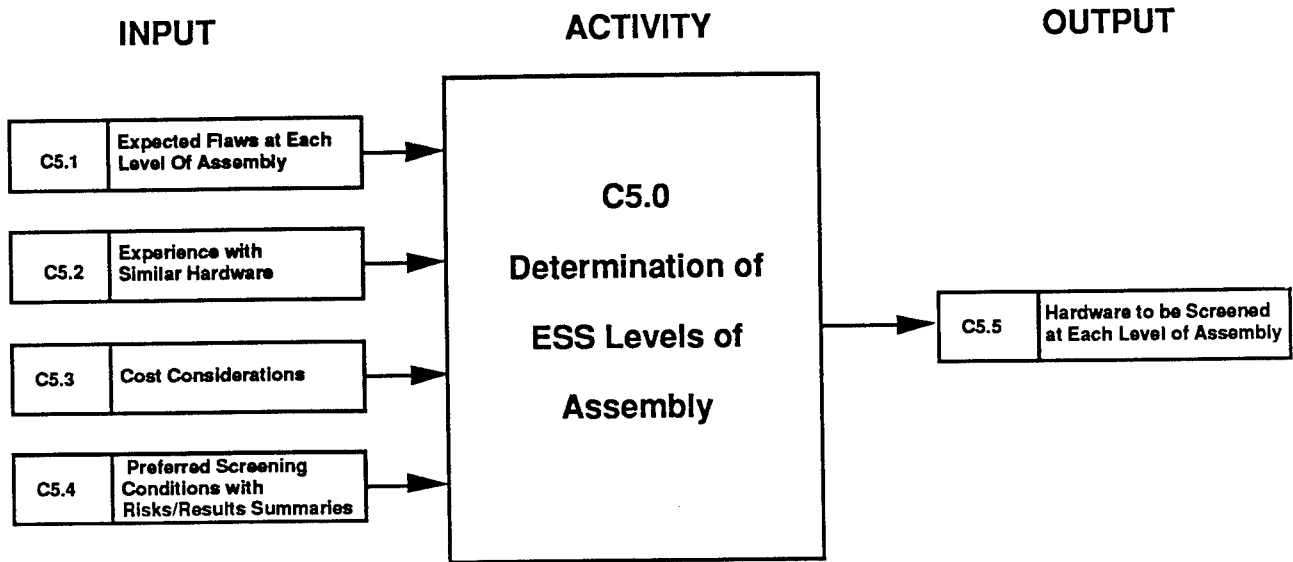

Figure 2.8. Activity C5.0: Determination of ESS Levels of Assembly

C5.0 ACTIVITY - Determination of ESS Levels of Assembly

This activity involves determining at which levels RV, TC, or both forms of ESS should be conducted for a given development. Printed Wiring Assembly (PWA), unit, and system are the three levels delineated here. When making the decision at which levels to screen at, a number of important variables should be taken into account. These include technical effectiveness, cost effectiveness, and index of failure detectability.

C5.1 INPUT - Expected Flaws at Each Level of Assembly

An understanding of the population of flaws to be expected at the various levels contributes greatly to the determination of ESS levels of assembly. This is the same as output C4.4.

C5.2 INPUT - Experience with Similar Hardware

Data available from past field or ESS experience is useful in setting initial profiles.

C5.3 INPUT - Cost Considerations

Cost should be considered when selecting ESS levels of assembly. An excessive cost at a higher level may lead to elimination of the screen with resultant increase in screening at a lower level.

C5.4 INPUT - Preferred Screening Conditions with Risks/Results Summaries

Several of the published ESS guidebooks provide tables containing information relative to cost, risks and results for screening at various levels of assembly and equipment conditions. The tables are useful for initial planning of ESS levels of assembly.

C5.5 OUTPUT - Hardware to be Screened at Each Level of Assembly

The choice of level of assembly for both random vibration and thermal cycling screens is the main output of this activity.

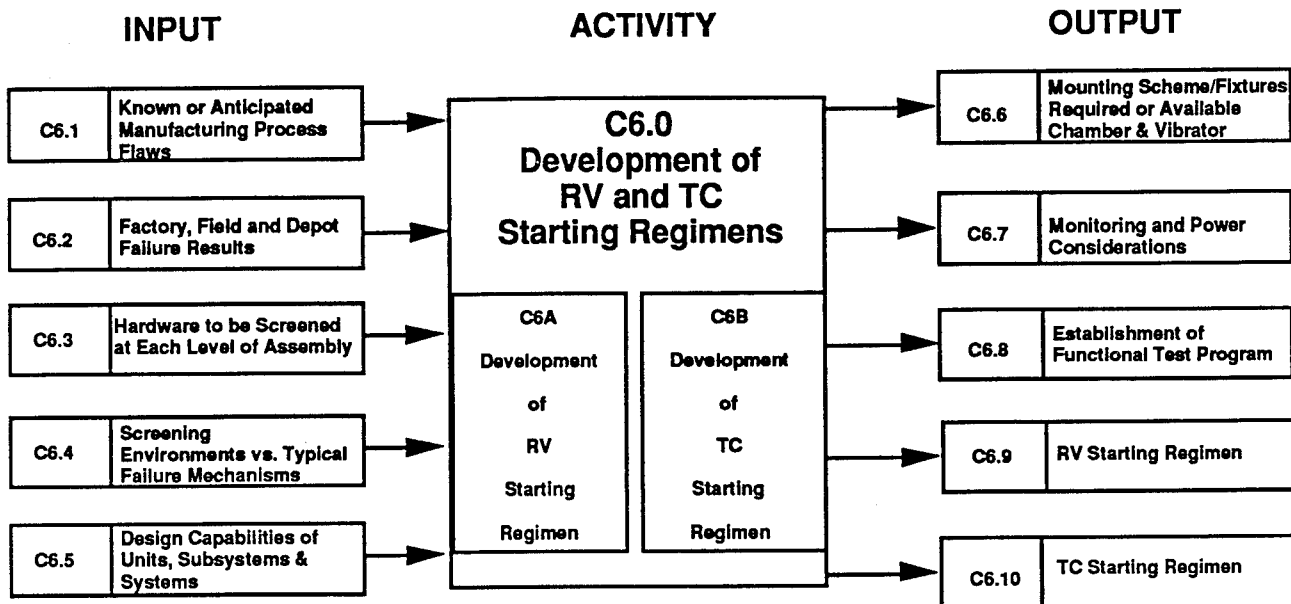

Figure 2.9. Activity C6.0: Development of RV and TC Starting Regimens

C6.0 ACTIVITY - Development of RV and TC Starting Regimens

This activity is broken down into two sub activities as shown. The sub activities are development of random vibration starting regimen and development of thermal cycling starting regimen. Flow diagrams for the sub activities are found below. Inputs to activity 6.0 apply to both sub activities.

C6.1 INPUT - Known or Anticipated Manufacturing Process Flaws

The choice of RV and TC screen selection is heavily dependent on known or anticipated flaws. Different types of screening scenarios are more effective than others depending on the flaw type anticipated. For example, thermal cycling is known to be effective in precipitating flaws caused by improper crimp, chemical contamination, wrong component placement, improper component installation and parameter drift. Vibration is more effective in screening out the effects of particle contamination, defective crystals, poorly bonded components and loose wires. This is the same as output C4.4.

C6.2 INPUT - Factory, Field and Depot Failure Results

The study of factory, field and depot failures is necessary to determine not only what flaws are anticipated and how to structure the screen, but also to determine how screens should be modified if they are too weak or too strong.

C6.3 INPUT - Hardware to be Screened at Each Level of Assembly

This is the same as output C5.5 above.

C6.4 INPUT - Screening Environments vs. Typical Failure Mechanisms

The various guidebooks provide tables which list failure types under three columns: thermal cycling, vibration, and thermal and/or vibration. This information can also be obtained from historical data. It is important to understand the various flaw types that can be precipitated by the two different types of ESS. This is the same as input C4.2.

C6.5 INPUT - Design Capabilities of Units, Subsystems, & Systems

Profiles must not exceed the design capabilities of the units, subsystems, and systems to be exposed to screening.

C6.6 OUTPUT - Mounting Schemes/Fixtures, Required or Available Chambers and Vibrators

This refers to those schemes, fixtures, chambers and vibrators that will be required for initial production screening.

C6.7 OUTPUT - Monitoring and Power Considerations

What points will be monitored during the screen and whether or not equipment will be fully functional/powerd with normal inputs and outputs should be decided at this time.

C6.8 OUTPUT - Establishment of Functional Test Program

The purpose of the test program established is to assure that the various flaws precipitated by ESS are detected.

C6.9 OUTPUT - Random Vibration Starting Regimen

See output C6A.6 below.

C6.10 OUTPUT - Thermal Cycling Starting Regimen

See output C6B.4 below.

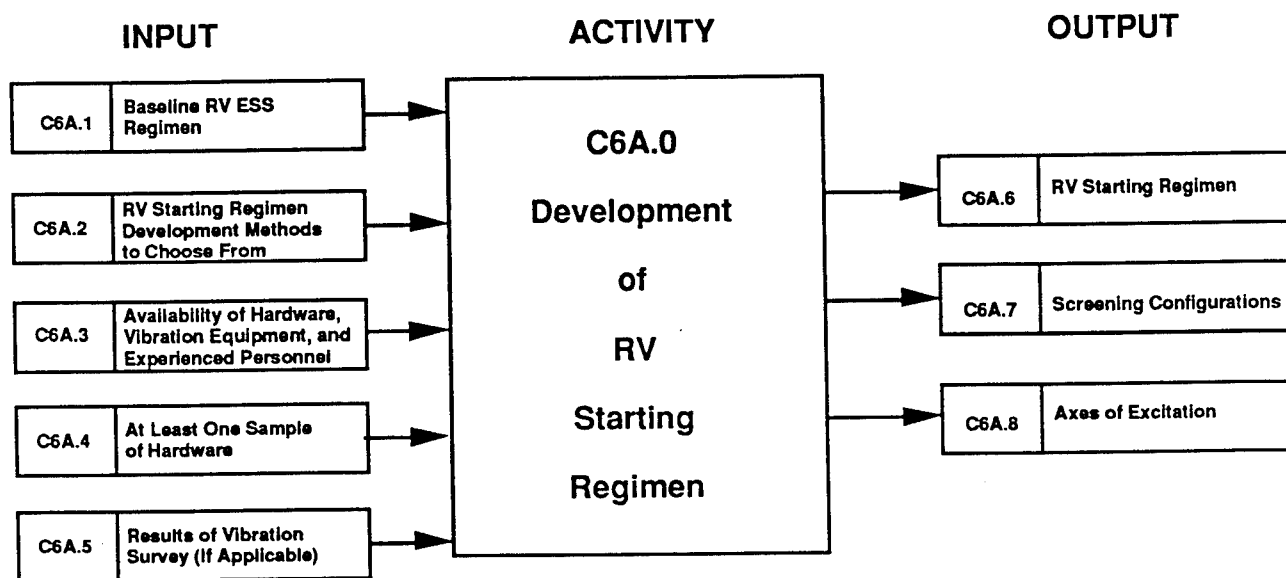

Figure 2.10. Activity C6A.0: Development of RV Starting Regimen

C6A.0 ACTIVITY - Development of Random Vibration Starting Regimen

This activity outlines the process for generating a starting regimen for random vibration ESS.

C6A.1 INPUT - Baseline RV ESS Regimen

Several references suggest using as a starting RV spectrum: 6 g_{RMS} consisting of .04 g²/Hz with a frequency range of 20 - 2000 Hz and 3 dB/octave rolloffs from 80 to 20 Hz and 350 to 2000 Hz. Some ESS guidebooks express caution when using this spectrum. It may be harmful with certain equipment types.

C6A.2 INPUT - RV Starting Regimen Development Methods to Choose From

The following methods are recommended for use in several ESS guidebooks: 1. Development of Input Spectrum Using Flaw Precipitation Threshold; 2. Development of Overall Screening Level Using Overall Internal Response Levels; 3. Development of Overall Screening Level Through Step-Stress Tests; 4. Development of Overall Screening Level Through Fault-Replication Tests; 5. Heritage Screens.

C6A.3 INPUT - Availability of Hardware, Vibration Equipment, and Experienced Personnel

This information is used to help decide on which of the five methods mentioned in input C6A.2 should be used.

C6A.4 INPUT - At Least One Sample of Hardware

A sample of hardware identical to that to be screened is needed along with any necessary functional test equipment.

C6A.5 INPUT - Results of Vibration Survey (If Applicable)

A vibration survey is used to measure the response of the equipment when exposed to vibration levels less severe than the actual screen. The results of the vibration survey are used with the first two of the RV starting regimen development methods listed in input C6A.2 above.

C6A.6 OUTPUT - Random Vibration Starting Regimen

Characteristics of an RV starting regimen include the spectrum which consists of a g_{RMS} value that is also represented graphically as power spectral density (g²/Hz) on the ordinate and frequency (Hz) on the abscissa. The graph will show rolloffs in dB/octave. Screen duration must also be determined.

C6A.7 OUTPUT - Screening Configurations

This includes fixture setups/installation required to stress out expected flaws.

C6A.8 OUTPUT - Axes of Excitation

A determination of the number of axes of excitation is required. One, two or three sequential axes will usually be sufficient. A historical base of flaw detection versus the number of axes should be kept.

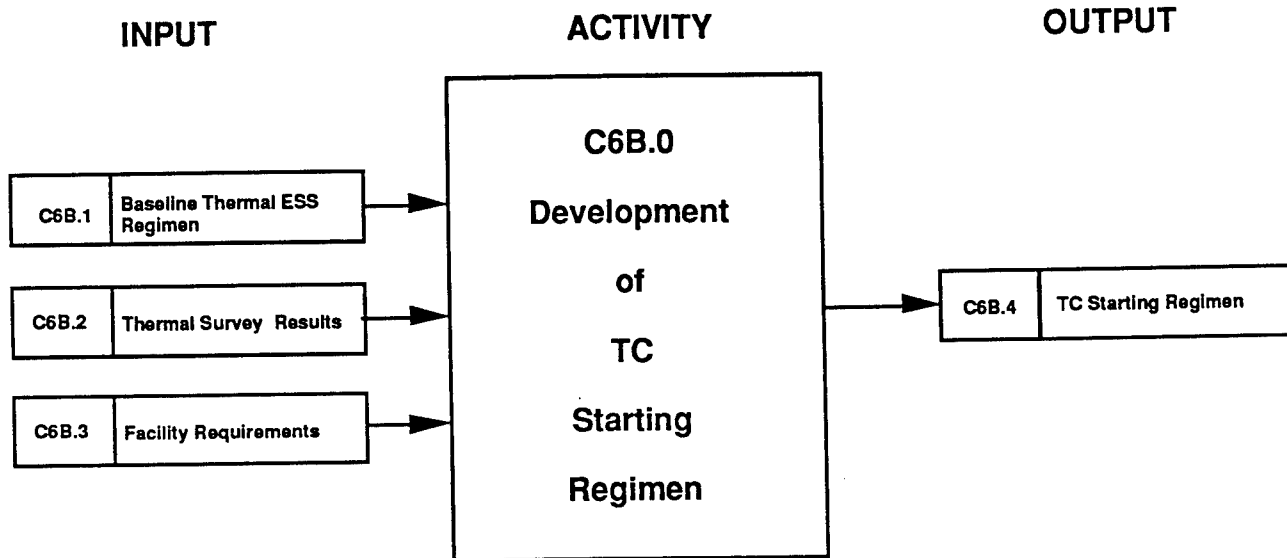

Figure 2.11. Activity C6B.0: Development of TC Starting Regimen

C6B.0 ACTIVITY - Development of Thermal Cycling Starting Regimen

This activity outlines the process for developing an initial thermal cycling starting regimen.

C6B.1 INPUT - Baseline Thermal ESS Regimen

A baseline regimen is provided in most guidebooks for those programs having no data on similar items. Tables are usually provided outlining recommended temperature ranges, rate of change, stabilization criteria, soak times, number of cycles, and equipment conditions. The information is normally provided for PWA, unit, and system levels of assembly.

C6B.2 INPUT - Thermal Survey Results

A thermal survey measures the thermal response during experimental temperature cycling of the equipment intended for TC ESS. The survey results are helpful in setting up the initial thermal cycling regimen.

C6B.3 INPUT - Facility Requirements

A chamber is required with adequate heating and cooling capacity as well as chamber air speed fast enough to produce the required temperature rate of change.

C6B.4 OUTPUT - Temperature Cycling Starting Regimen

The TC starting regimen includes the following characteristics: number of cycles, for each cycle the high and low temperature, the temperature rate of change, the dwell times at the high and low temperatures, whether the equipment is powered or unpowered and monitored or unmonitored.

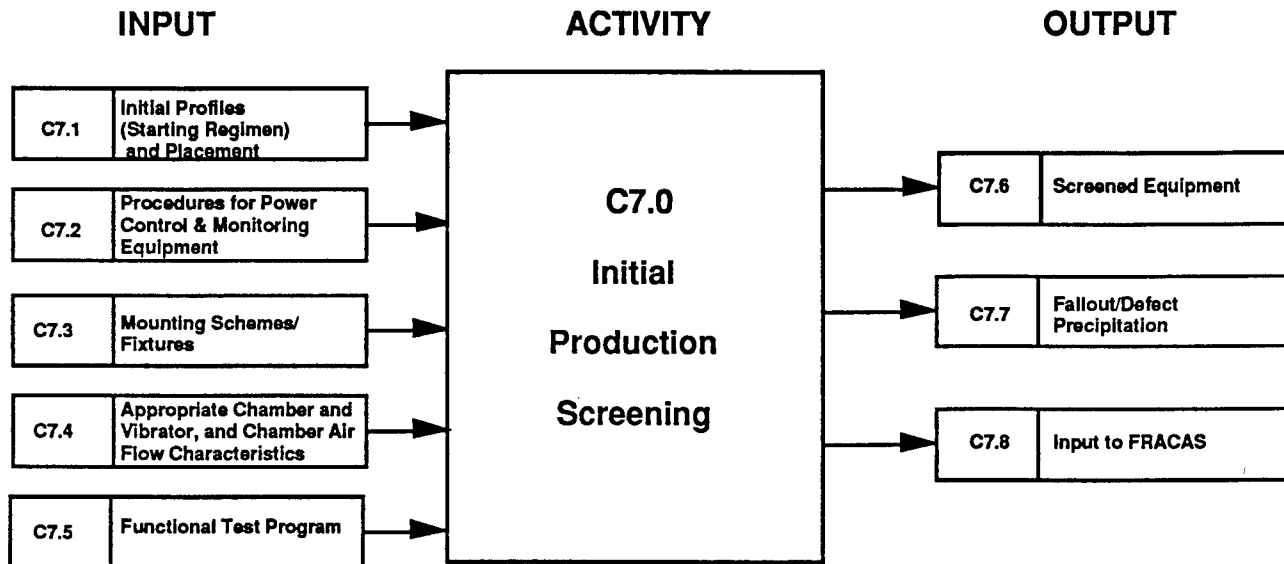

Figure 2.12. Activity C7.0: Initial Production Screening

C7.0 ACTIVITY - Initial Production Screening

The initial production screening is the first screening conducted on the production lot. Lessons are learned from the initial screening to help optimize/refine screening profiles and placement.

C7.1 INPUT - Initial Profiles (Starting Regimen) and Placement

This information is derived from outputs C6A.6, C6A.7, and C6A.8 for random vibration, output C6B.4 for temperature cycling, and output C5.5 for level of assembly determination

C7.2 INPUT - Procedures for Power Control & Monitoring Equipment

This information is derived from output C6.7 and from existing/known ESS procedures. The procedures include equipment installation, method of power control, monitoring and test.

C7.3 INPUT - Mounting Schemes/Fixtures

The same as output C6.6.

C7.4 INPUT - Appropriate Chamber and Vibrator, and Chamber Air Flow Characteristics

This information is also derived from output C6.6.

C7.5 INPUT - Functional Test Program

This is the test program that is defined as output C6.8 for the purpose of assuring that precipitated flaws are detected.

C7.6 OUTPUT - Screened Equipment

The main output of the initial production screening activity is the screened equipment.

C7.7 OUTPUT - Fallout/Defect Precipitation

All defective equipment resulting from ESS and detected by test means.

C7.8 Input to FRACAS

Information relative to failure type and circumstances of occurrence should all be logged to the FRACAS.

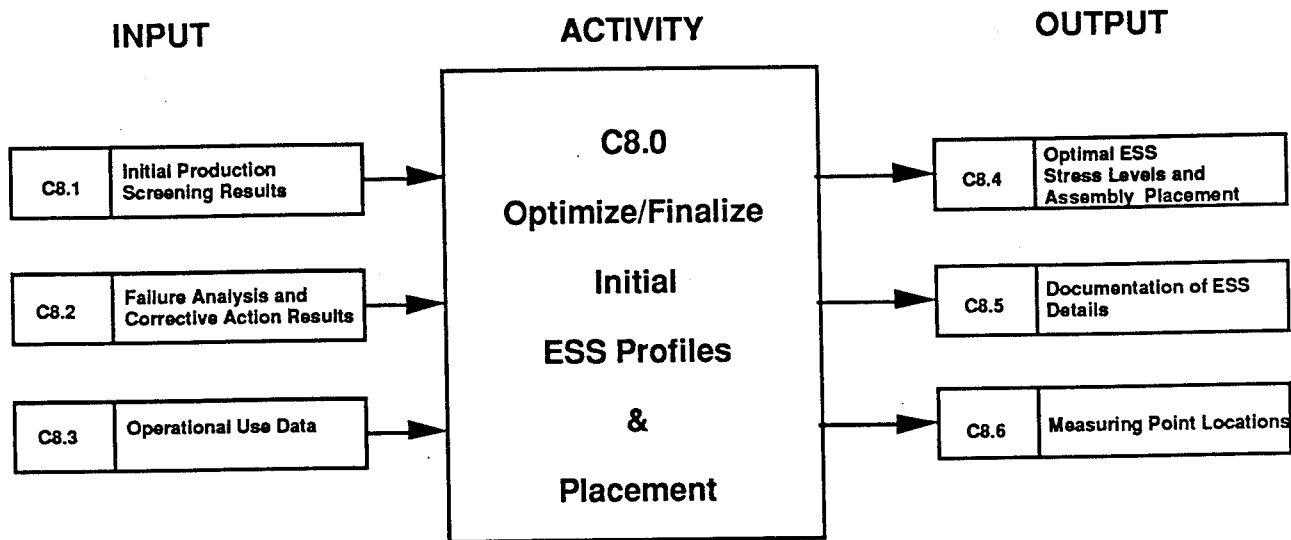

Figure 2.13. Activity C8.0: Optimize/Finalize Initial ESS Profiles & Placement

C8.0 ACTIVITY - Optimize/Finalize Initial ESS Profiles & Placement

As soon as initial production screening takes place, results should be available to modify ESS profiles and placement for full production ESS.

C8.1 INPUT - Initial Production Screening Results

This includes the initial fallout records (Output C7.7) and any other lessons learned/observation from Activity C7.0, Initial Production Screening.

C8.2 INPUT - Failure Analysis and Corrective Action Results

Determinations can be made as to whether or not precipitated defects were due to overstress. FRACAS data is a good source for this information.

C8.3 INPUT - Operational Use Data

Failure analysis results should not only include those from initial production screening but also any available field results.

C8.4 OUTPUT - Optimal ESS Stress Levels and Assembly Placement

Upon study of the inputs to this activity, optimal stress levels that will precipitate defects but not overstress the equipment should be generated. Appropriate level of placement can also be refined at this time.

C8.5 OUTPUT - Documentation of ESS Details

Appropriate details are documented to maintain a current technical data package.

C8.6 OUTPUT - Measuring Point Locations

Final measuring point locations for production screening are determined/finalized at this time.

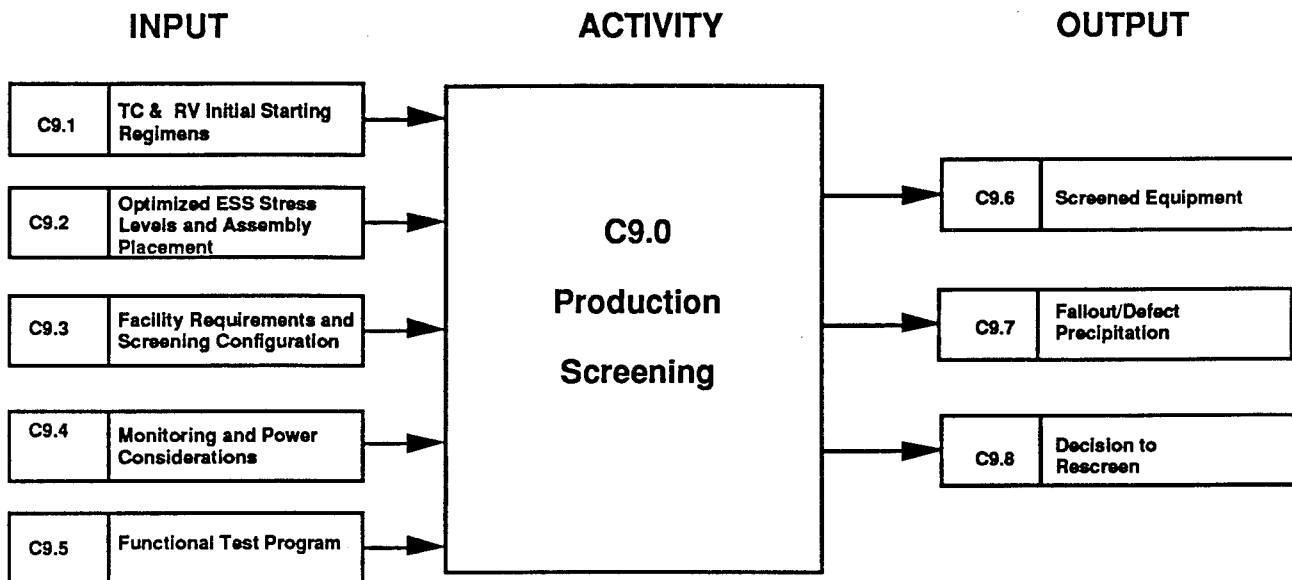

Figure 2.14. Activity C9.0: Production Screening

C9.0 ACTIVITY - Production Screening

This activity involves the actual screening of production hardware.

C9.1 INPUT - TC & RV Initial Starting Regimens

This includes all information derived from outputs C6A.6, C6A.7, C6A.8, and C6B.4.

C9.2 INPUT - Optimized ESS Stress Levels and Assembly Placement

This is the same as output C8.4.

C9.3 INPUT - Facility Requirements and Screening Configurations

All requirements for both shakers and thermal chambers must be met at this time. This includes appropriate mounting schemes and fixtures (Input C7.3), required chambers and vibrators, and appropriate chamber air flow requirements.

C9.4 INPUT - Procedures for Power Control & Monitoring of Equipment

This information is derived from output C6.7 and from existing/known ESS procedures.

C9.5 INPUT - Functional Test Program

This is the same as input C7.5. Included are full functional pre and post screen tests as well as functional monitoring capabilities during ESS. Assurance of all proper measuring point locations is necessary at this time.

C9.6 OUTPUT - Screened Equipment

The main output of the production screening activity is the screened equipment.

C9.7 OUTPUT - Fallout/Defect Precipitation

All defective equipment resulting from ESS which is detected by ordinary test means.

C9.8 Decision to Rescreen

Rescreening to certain levels/stresses after repairs are made is often necessary.

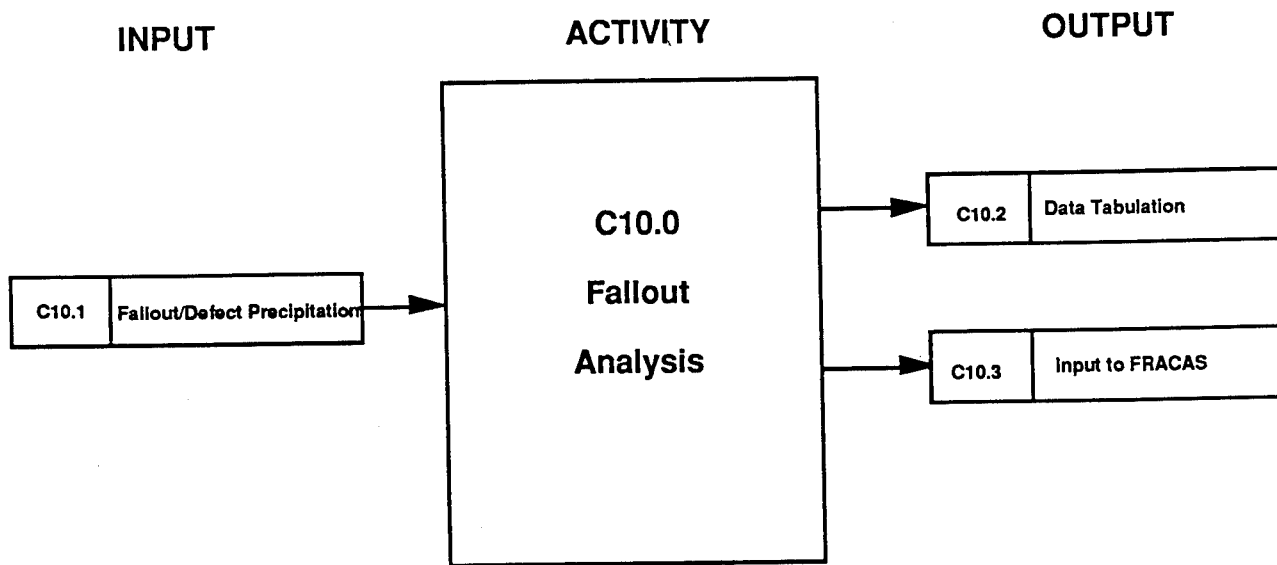

Figure 2.15. Activity C10.0: Fallout Analysis

C10.0 ACTIVITY - Fallout Analysis

This activity involves an assessment of the flaw types to assure feedback and a positive effect on the manufacturing process. It also involves preparation of data for use with any quantitative procedures for monitor and control.

C10.1 INPUT - Fallout/Defect Precipitation

This is the same as output C9.7.

C10.2 OUTPUT - Data Tabulation

Data is tabulated for use in ESS process control or any other quantitative monitoring.

C10.3 OUTPUT - Input To FRACAS

All failure data are to be made available to the in-place FRACAS system.

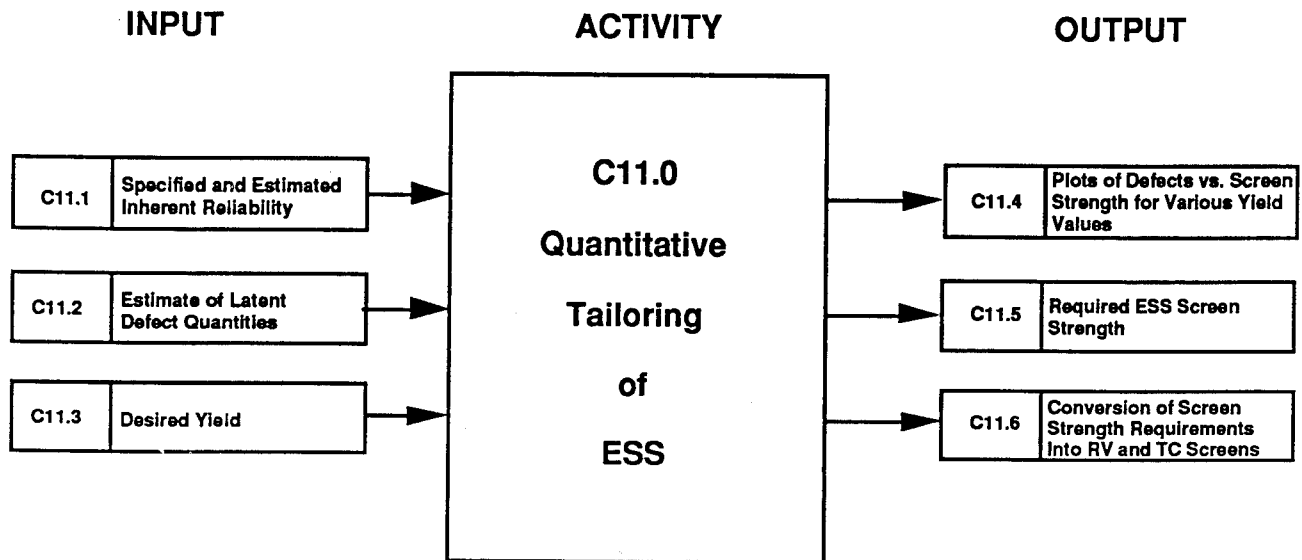

Figure 2.16. Activity C11.0: Quantitative Tailoring of ESS

C11.0 ACTIVITY - Quantitative Tailoring of ESS

The Institute of Environmental Sciences (IES) guidebook contains an appendix which outlines an approach for determining required screen strengths based on reliability requirements. The quantitative aspect of the classical ESS process is much less detailed than the Mil-Hdbk-344 approach which is a complete quantitative approach to ESS.

C11.1 INPUT - Specified and Estimated Inherent Reliability

The inherent reliability is estimated from prediction or other appropriate methods. The specified reliability is that value required by the customer to satisfy objectives.

C11.2 INPUT - Estimate of Latent Defect Quantities

An estimate of the quantity of latent defects present is obtained by data from a previous population. If no prior data is available, a method is provided in the IES guidebook to estimate defects present.

C11.3 INPUT - Desired Yield

The desired yield and the estimate of defects present are used to tailor screening strength by the methods provided in the IES guidebook.

C11.4 OUTPUT - Plots of Defects vs. Screen Strength for Various Yield Values

Mathematical methods are provided in the IES guidebook to graphically illustrate a family of first pass yield curves with the ordinate being defects and the abscissa screen strength.

C11.5 OUTPUT - Required ESS Screen Strength

The required ESS screen strength is extracted from the plot discussed above in output C11.4.

C11.6 OUTPUT - Conversion of Screen Strength Required Values Into Appropriate RV and TC Screens

The main output of the quantitative tailoring is what required screen strength values are and the conversion of such into RV and TC screens.

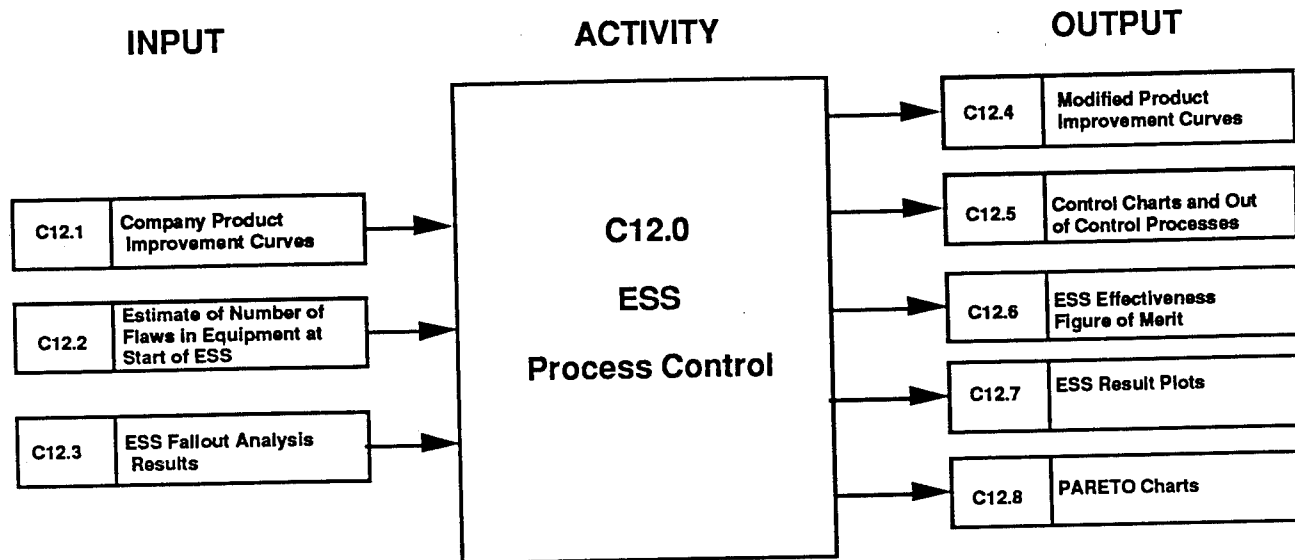

Figure 2.17. Activity C12.0: ESS Process Control

C12.0 ACTIVITY - ESS Process Control

Methodology is provided to help in assuring and controlling both the ESS process of precipitating latent defects to failure and the capability of the production process. The control methods depicted here were derived from the IES guidebook.

C12.1 INPUT - Company Product Improvement Curves

A product improvement curve plots the average number of failure reports per item of final product against product sequential serial numbers.

C12.2 INPUT - Estimate of Number of Flaws in Equipment at Start of ESS

The IES guidebook provides a method to estimate the number of flaws based on the slope of the product improvement curve, complexity of the hardware, and serial number.

C12.3 INPUT - ESS Fallout Analysis Results

This includes results from activity C10.0. ESS fallout results are necessary to construct control charts, result plots, and PARETO charts as defined below. An ESS effectiveness figure of merit can also be computed from the results.

C12.4 OUTPUT - Modified Product Improvement Curves

As data on ESS fallout is accumulated the product improvement curves should be adjusted accordingly.

C12.5 OUTPUT - Control Charts and Out of Control Processes

Control charts plot failures on the y-axis and number of items screened on the x-axis. The IES guidebook provides a method for structuring the control charts, i.e., upper and lower control limits. When a point falls outside of the control limits, the process should be checked for problems. ESS can help to pinpoint manufacturing problems. When an abnormal number of a certain defect type is precipitated during a screen this is an indication that the process may be out of control.

C12.6 OUTPUT - ESS Effectiveness Figure of Merit

The IES document provides a gross figure of merit which can be used in some cases. The figure of merit is defined as the ratio between the average total failures per item and the number of flaws per item at the start of ESS. The guidebook recommends the use of control charts as a better method of controlling the screening process.

C12.7 OUTPUT - ESS Result Plots

ESS result plots are recommended for use in lieu of control charts when a predetermined value for failures per equipment is not available but a value for failures per cycle is. In this case failures per unit would be plotted against number of thermal cycles. The plots should be used to increase or decrease the number of cycles in the screen.

C12.8 OUTPUT - PARETO Charts

As a supplement to control charts, it is sometimes useful to generate a PARETO chart to display a breakdown of failure causes.

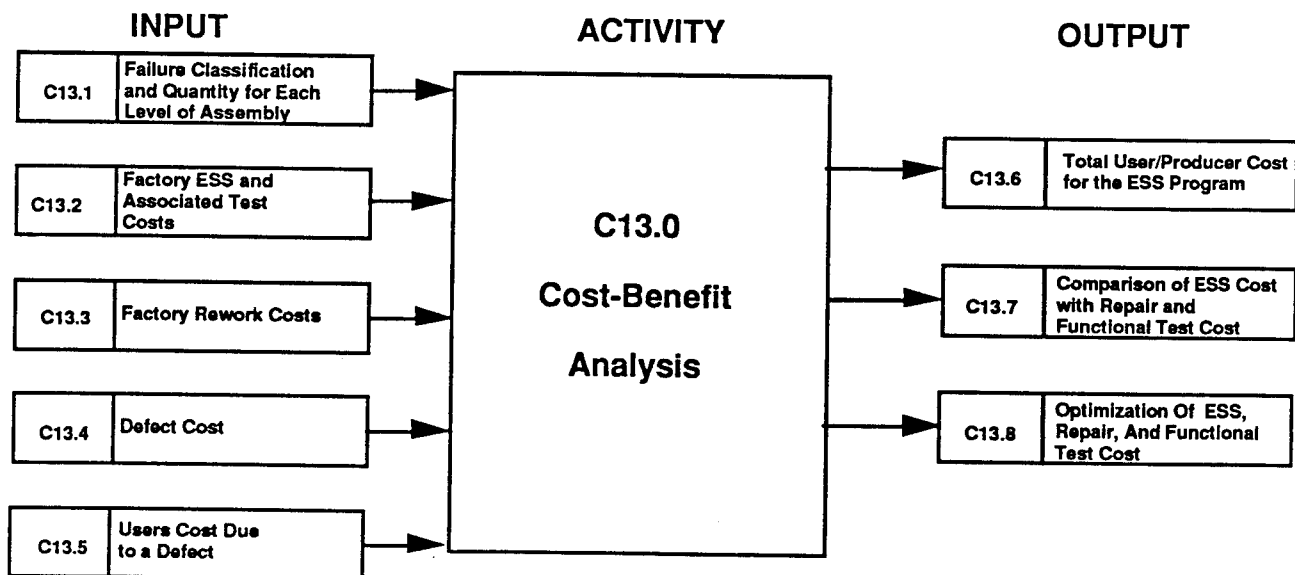

Figure 2.18. Activity C13.0: Cost-Benefit Analysis

C13.0 ACTIVITY - Cost-Benefit Analysis

A cost-benefit analysis is used to optimize repair and test costs against required levels of ESS. The cost analysis can be accomplished through use of a personal computer spreadsheet program.

C13.1 INPUT - Failure Class. and Quantity for Each Level of Assembly

For the module, unit, and system levels of assembly, failure descriptions and flaws precipitated through pre-screen testing, screening, and post-screening are tabulated.

C13.2 INPUT - Factory ESS and Associated Test Costs

An input to the cost-benefit analysis is the cost associated with screening and the functional testing conducted subsequent to screening.

C13.3 INPUT - Rework Costs

Costs associated with both part and non-part rework are used to compute an overall total rework cost for each screen and functional test at each level of assembly.

C13.4 INPUT - Defect Cost

The defect cost is determined by multiplying the number of defects at each stage by the cost to repair each defect.

C13.5 INPUT - Users Cost Due to a Defect

This cost treats the field as an extension of the ESS test flow by determining the users cost associated with a defect.

C13.6 OUTPUT - Total User/Producer Cost for the ESS Program

The total user/producer cost is the sum of inputs C13.2, C13.3, C13.4 and C13.5.

C13.7 OUTPUT - Comparison of ESS Cost with Repair and Functional Test Cost

The main output of the cost-benefit analysis a comparison of the cost of screening and functional test with those costs associated with rework and repair at each level of assembly.

C13.8 OUTPUT - Optimization of Repair and Functional Test Cost

This is the end result of the cost-benefit analysis. It involves optimizing ESS levels of assembly.

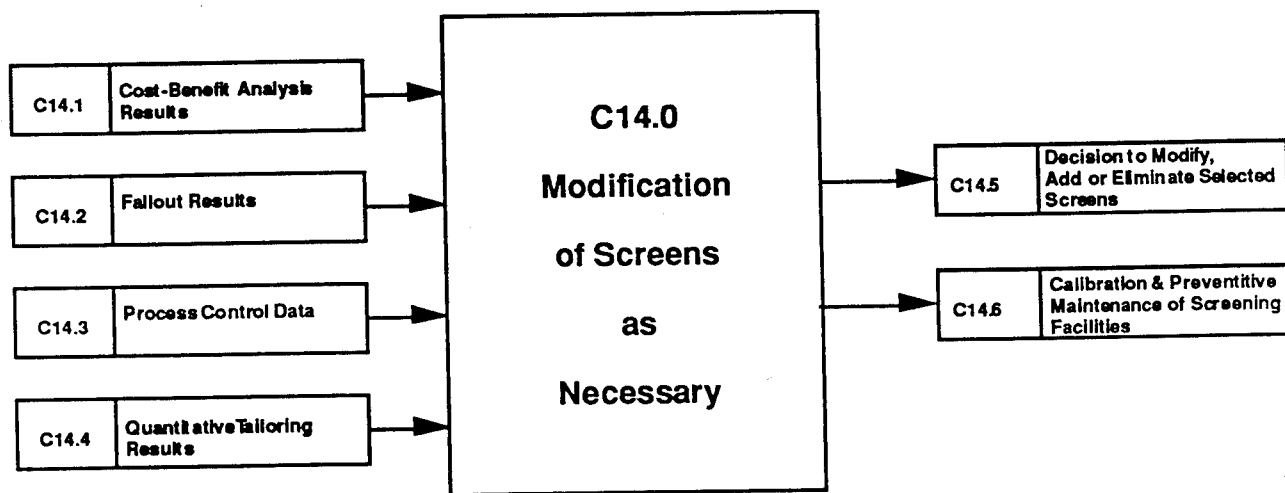

Figure 219. Activity C14.0: Modification of Screens as Necessary

C14.0 ACTIVITY - Modification of Screens as Necessary

During the course of a screening program it is often necessary to modify screening regimens based on observed and calculated results.

C14.1 INPUT - Cost-Benefit Analysis Results

Results of activity C13.0.

C14.2 INPUT - Fallout Results

Results of activity C10.0.

C14.3 INPUT - Process Control Data

Results of activity C12.0.

C14.4 INPUT - Quantitative Tailoring Results

Results of activity C11.0.

C14.5 OUTPUT - Decision to Modify, add or Eliminate Selected Screens

Screens are modified as fallout or a lack of fallout are observed. If a new class of defects is discovered, ESS should be modified accordingly.

C14.6 OUTPUT - Calibration & Preventive Maintenance of Screening Facilities

Proper maintenance of the ESS equipment is necessary. Periodic calibration and maintenance is necessary to assure that the facilities remain accurate and operable.

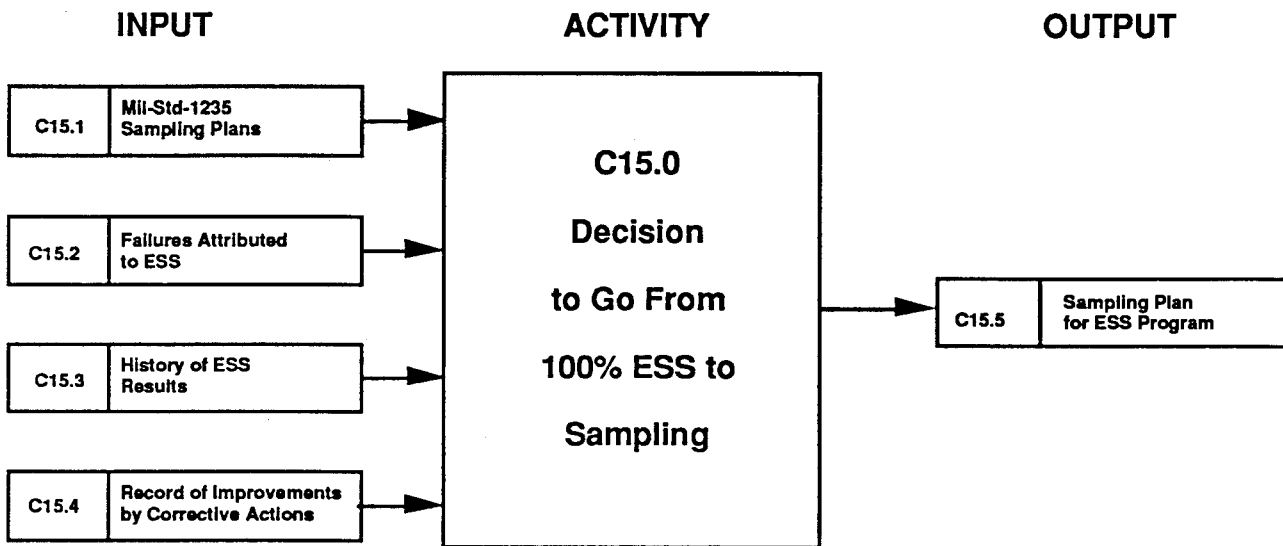

Figure 2.20. Activity C15.0: Decision to Go From 100% ESS to Sampling

C15.0 ACTIVITY - Decision to Go From 100% ESS to Sampling

At the point in time when manufacturing processes and parts are under control and ESS is no longer precipitating a significant number of defects, a decision must be made to go from 100% ESS to sampling. If process control is lost at any time, the tri-service guidebook recommends reverting to 100% ESS.

C15.1 INPUT - Mil-Std-1235 Sampling Plans

This standard is titled "Single-and Multi-Level Continuous Sampling Procedures and Tables for Inspection by Attributes". It provides methods for applying continuous sampling plans for inspection.

C15.2 INPUT - Failures Attributed to ESS

This information is derived from output C9.7.

C15.3 INPUT - History of ESS Results

C15.4 INPUT - Record of Improvements by Corrective Actions

C15.5 OUTPUT - Sampling Plan for ESS Program

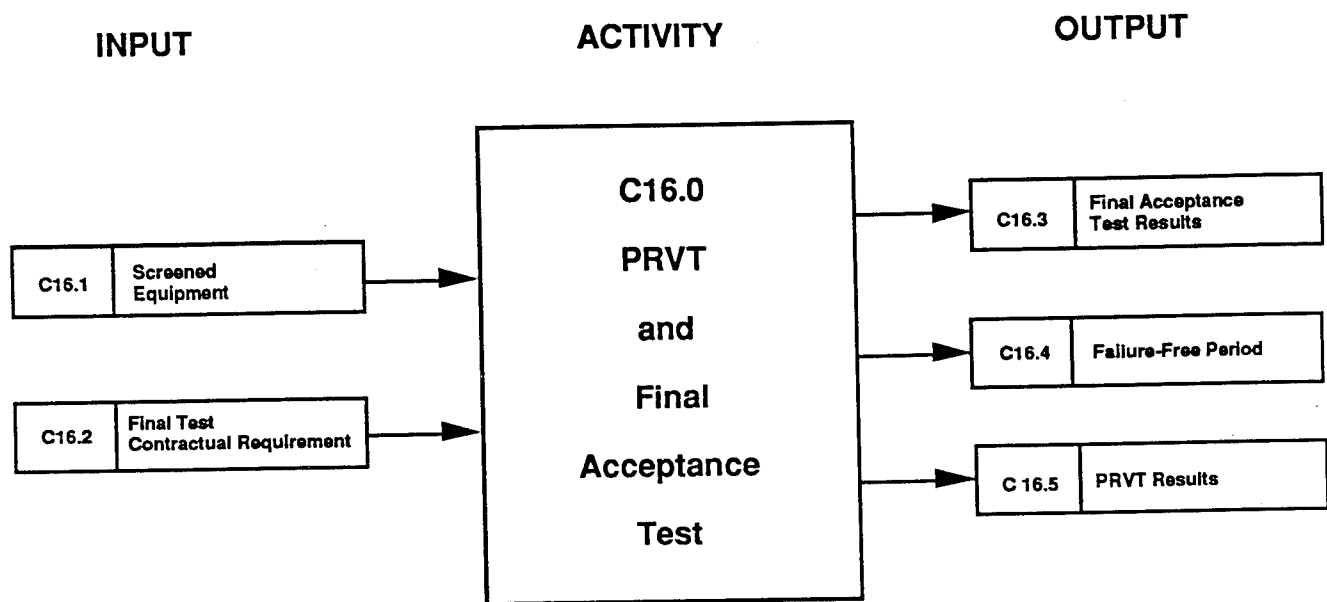

Figure 2.21. Activity C16.0: PRVT and Final Acceptance Test

C16.0 ACTIVITY - PRVT and Final Acceptance Test

The final acceptance test is conducted after all ESS and post ESS functional test. At times, a production reliability verification test (PRVT) may be required/desired. PRVT is the portion of ESS retained for the purpose of providing a mechanism to indicate whether or not the process is in control and whether or not reliability is being achieved.

C16.1 INPUT - Screened Equipment

This is the same as output C9.6.

C16.2 INPUT - Final Test Contractual Requirement

The customer generated requirements or equipment specifications may call for some sort of PRVT and/or final acceptance test.

C16.3 OUTPUT - Final Acceptance Test Results

This involves the customer either accepting or rejecting the equipment based on results of a reliability production acceptance test. Rejection will involve repair and return to an improved manufacturing process.

C16.4 OUTPUT - Failure-Free Period

Determination of a failure-free requirement for the final acceptance test may be required.

C16.5 OUTPUT - PRVT Results

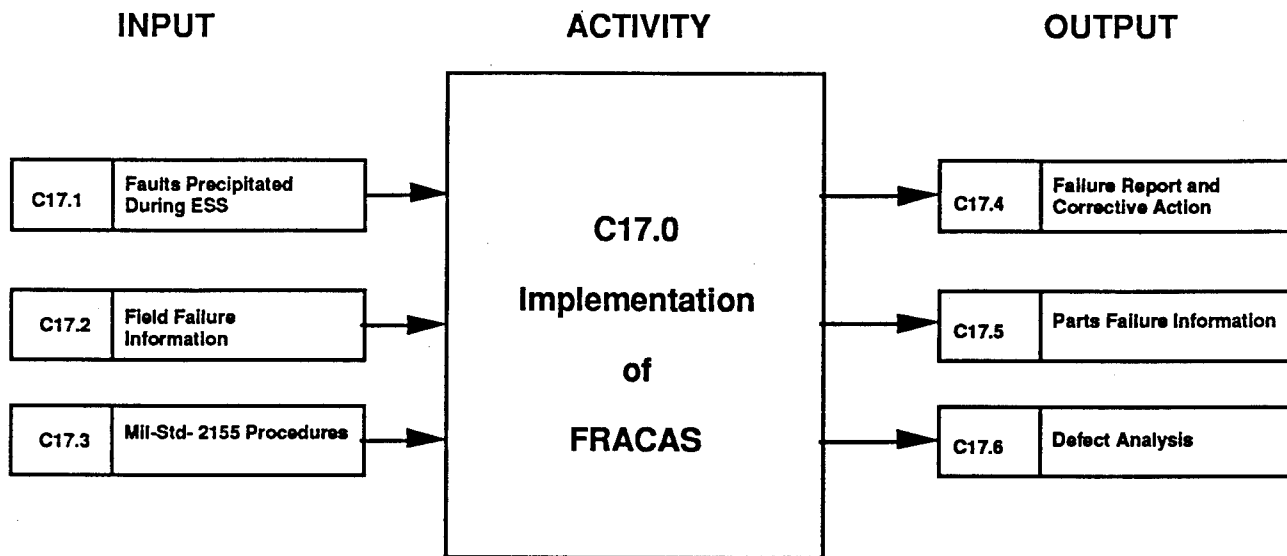

Figure 2.22 Activity C17.0: Implementation of FRACAS

C17.0 Activity - Implementation of FRACAS

A FRACAS - failure reporting, analysis and corrective action system should be in place at the contractor facility. Its interaction with the ESS program is outlined here.

C17.1 INPUT - Faults Precipitated During ESS

All faults precipitated during screening should be reported and analyzed by the contractors closed loop FRACAS.

C17.2 INPUT - Field Failure Information

Procedures should be in place to track and record field failure information.

C17.3 INPUT - Mil-Std-2155 Procedures

Mil-Std-2155, "Failure Reporting, Analysis And Corrective Action System" establishes requirements and criteria for a FRACAS.

C17.4 OUTPUT - Failure Report and Corrective Action

Includes failure reports which specify all failures precipitated during ESS. Corrective action procedures are necessary to correct any parts, equipment design, manufacturing or test procedure problems uncovered during the screening process.

C17.5 OUTPUT - Parts Failure Information

Parts failure information should be supplied to manufacturers for the purpose of continuous improvement.

C17.6 OUTPUT - Defect Analysis

An analysis of all defects is necessary to determine corrective actions for improvement of the manufacturing process.

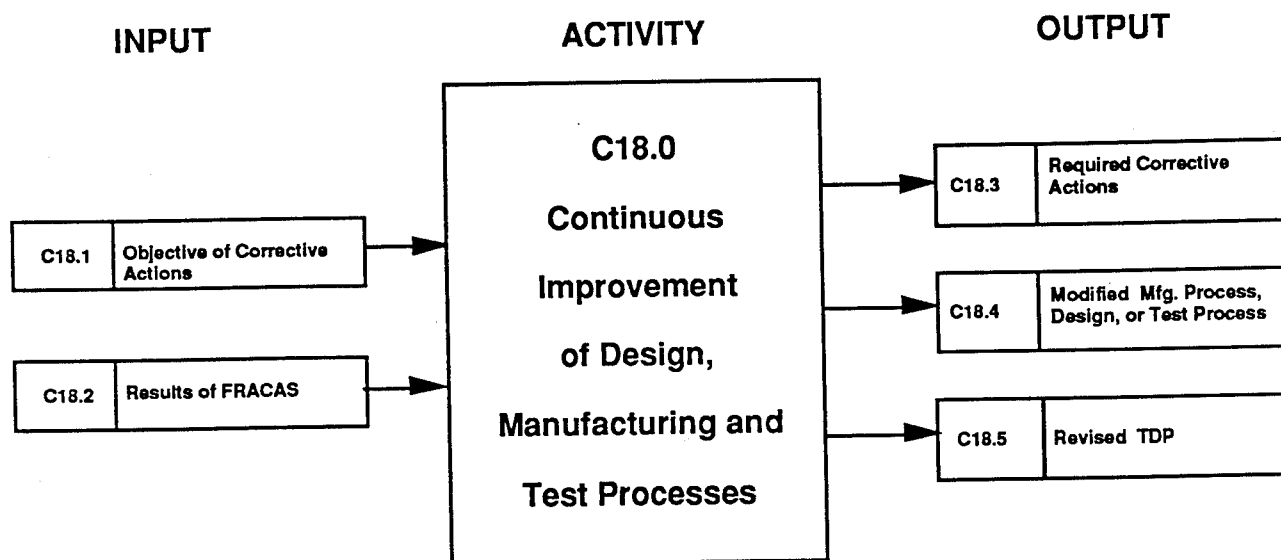

Figure 2.23. Activity C18.0: Continuous Improvement of Design, Manufacturing and Test Processes

C18.0 ACTIVITY - Continuous Improvement of Design, Manufacturing and Test Processes

Environmental Stress Screening can help to optimize the manufacturing process thereby resulting in cost savings. This activity illustrates how ESS interacts with the continuous improvement process.

C18.1 INPUT - Objective of Corrective Action

Specific objectives of corrective action should be spelled out. This can be derived from output C17.4.

C18.2 INPUT - Results of FRACAS

This includes information pertaining to any improvements to the design, manufacturing, and test processes resulting from the closed loop FRACAS.

C18.3 OUTPUT - Required Corrective Actions

Actions reported to engineering disciplines responsible for design, manufacturing and test to improve their processes.

C18.4 OUTPUT - Modified Manufacturing, Design, or Test Processes

C18.5 OUTPUT - Revised Technical Data Package

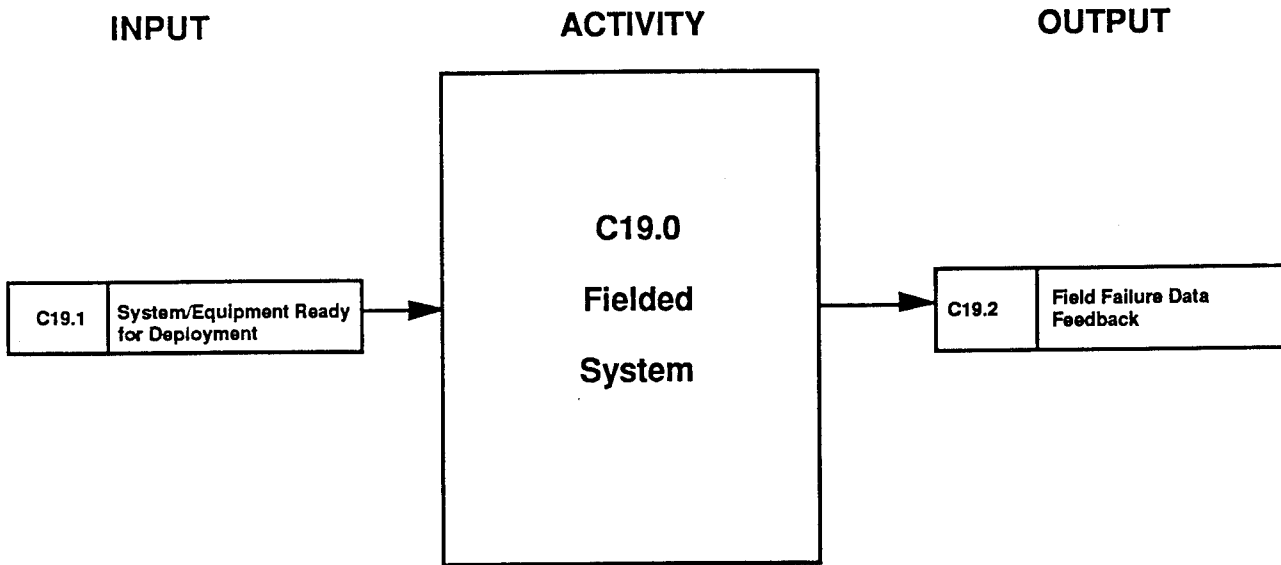

Figure 2.24 Activity C19: Fielded System

C19.0 ACTIVITY - Fielded System

This activity involves feeding back failure information from the field to the FRACAS system.

C19.1 INPUT - System/Equipment Ready for Deployment

The final equipment/system accepted by the customer and ready for field deployment.

C19.2 OUTPUT - Field Failure Data Feedback

This involves the user sending field failure data back to the FRACAS. The data is valuable to aid in process improvement

Q1.0 ACTIVITY - Preparation of ESS Plans - Same as activity C1.0

Q2.0 ACTIVITY - Assurance of Incoming Parts Quality Levels - Same as activity C2.0

Q3.0 ACTIVITY - Additional Part Screening (Rescreening) - Same as activity C3.0

Q4.0 ACTIVITY - Identify Nature of Anticipated Defects - Same as activity C4.0

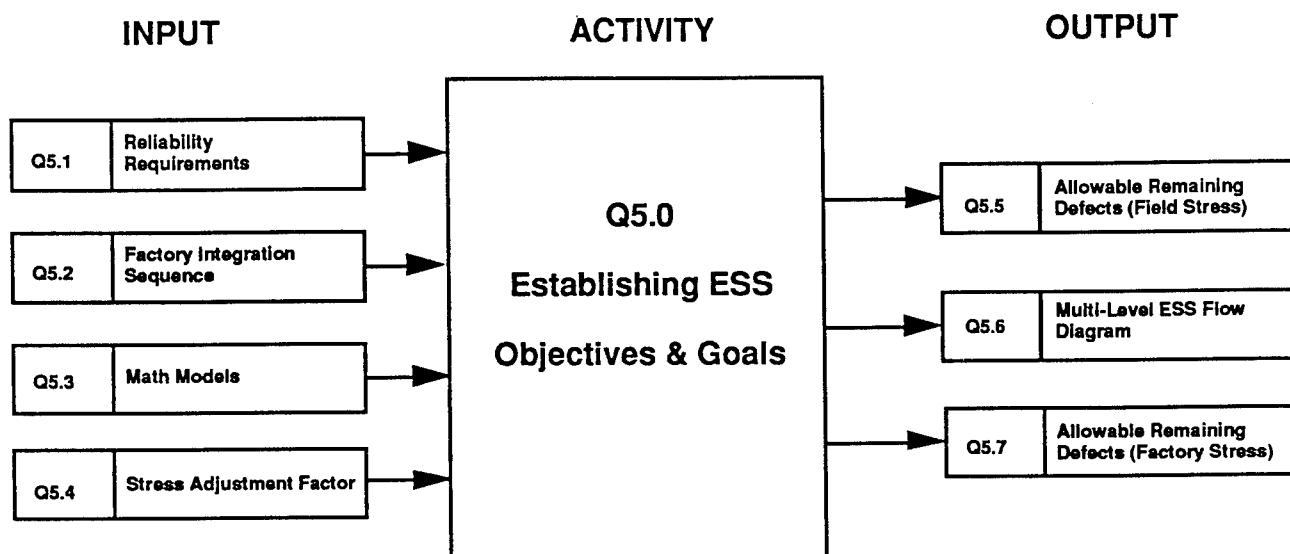

Figure 2.25. Activity Q5.0: Establishing ESS Objectives & Goals

Q5.0 ACTIVITY - Establishing ESS Objectives & Goals

Mil-Hdbk-344 provides methods to relate reliability requirements to allowable remaining defect density values. This activity marks the first phase of the quantitative modeling and goal setting.

Q5.1 INPUT - Reliability Requirements

Values of limiting or inherent mean time between failure (MTBF) and required MTBF must be known in order to determine the maximum number of permissible remaining defects. These values will usually come from contract documents and/or product specifications.

Q5.2 INPUT - Factory Integration Sequence

The factory integration sequence must be defined with all restrictions and requirements with respect to assembly, calibration and acceptance testing.

Q5.3 INPUT - Math Models

The models found in the Mil-Hdbk-344A are used to compute the allowable remaining defects based on the reliability requirements.

Q5.4 INPUT - Stress Adjustment Factor (SAF)

The SAF is the ratio of the number of defects at the field stress level to those at baseline(factory) stress level. This value is used to adjust the allowable remaining defect value at field stress to an equivalent value at factory stress. The SAF becomes available during activity Q6B.0 and is output Q6B.7.

Q5.5 OUTPUT - Allowable Remaining Defects (Field Stress)

Based on the math models discussed in input Q5.3 and the reliability requirements discussed in input Q5.1, the allowable remaining defects at field stress are estimated.

Q5.6 OUTPUT - Multi-Level ESS Flow Diagram

A flow diagram is to be developed depicting the integration and environmental testing requirements. This diagram illustrates the production flow and provides the framework for ESS selection and placement.

Q5.7 OUTPUT - Allowable Remaining Defects (Factory Stress)

This value is calculated using the math model found in Procedure A1, section 5.2.3 of Mil-Hdbk-344A.

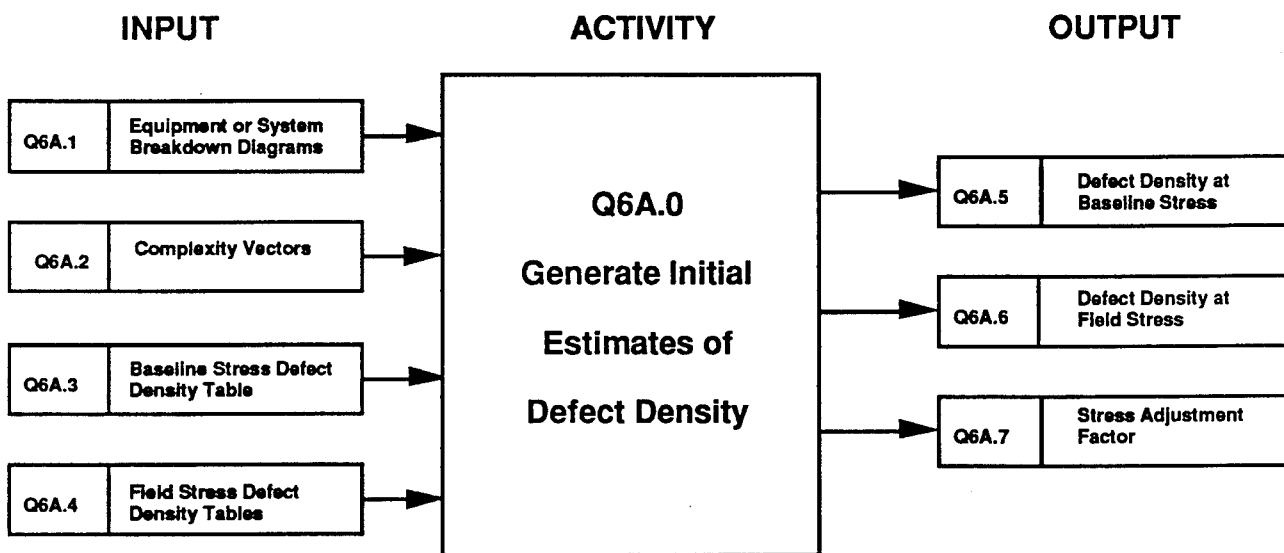

Figure 2.26A. Activity Q6A.0: Generate Initial Estimates of Defect Density

Q6A.0 ACTIVITY - Generate Initial Estimates of Defect Density

The intent of this activity is to estimate the initial defects resident in each assembly both from a baseline (factory) and a field stress perspective.

Q6A.1 INPUT - Equipment or System Breakdown Diagrams

A three level equipment breakdown structure is recommended: system, unit, and assembly level.

Q6A.2 INPUT - Complexity Vectors

The assembly complexity vector or matrix comprises the individual complexity vectors for each assembly and subassembly. This basically defines all part types, quantities, connections, leads, terminals, wire connections and PWAs.

Q6A.3 INPUT - Baseline Stress Defect Density Table

Mil-Hdbk-344A provides this table which contains values of defect density for a factory screening environment for various electronic component types and assembly activities.

Q6A.4 INPUT - Field Stress Defect Density Tables

Mil-Hdbk-344A also provides tables which contain values of defect density for various field environments and quality levels.

Q6A.5 OUTPUT - Defect Density At Baseline Stress

The initial estimated number of defects at baseline stress is determined by multiplying the assembly complexity vector by the baseline stress defect density vector values obtained from INPUT Q6A.3.

Q6A.6 OUTPUT - Defect Density At Field Stress

The initial estimated number of defects at field stress is determined by multiplying the assembly complexity vector by the field stress defect density vector values obtained from INPUT Q6A.4.

Q6A.7 OUTPUT - Stress Adjustment Factor (SAF)

The SAF is determined as the ratio of the number of defects at the field stress level to the number of defects at the baseline stress level.

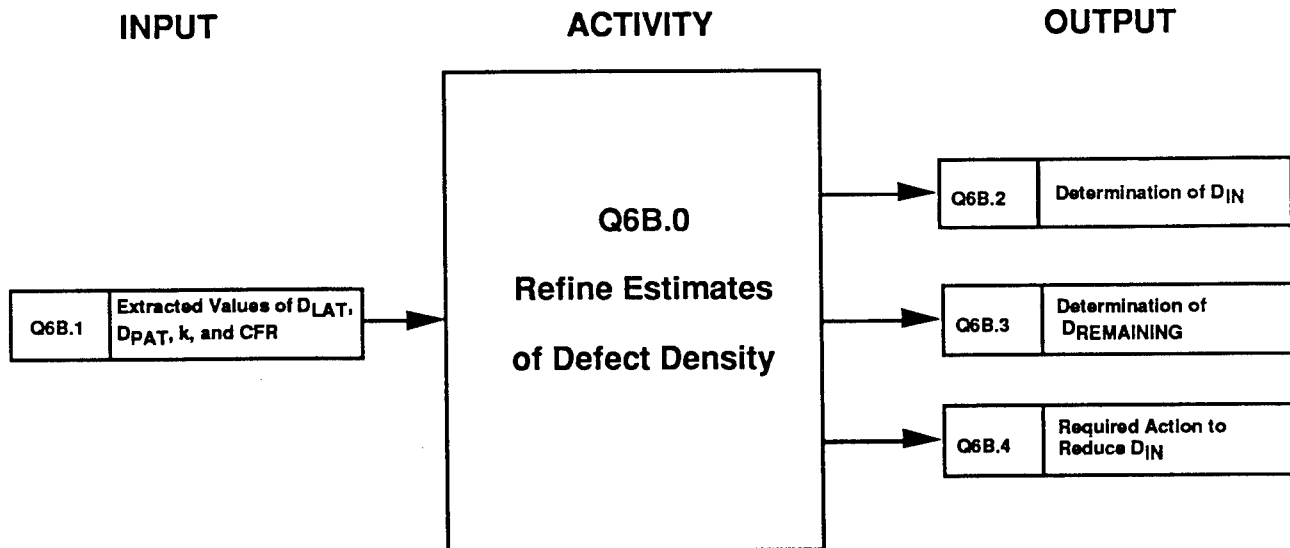

Figure 2.26B. Activity Q6B.0: Refine Estimates of Defect Density

Q6B.0 ACTIVITY - Refine Estimates of Defect Density

This activity involves the computation of incoming defect density (D_{IN}) and remaining defect density ($D_{REMAINING}$) from analysis of fallout data. The values are used to indicate if action is required to reduce incoming defect density. This activity takes place after activities Q14 "Fallout Analysis" and Q15 "Monitor and Control".

Q6B.1 INPUT - Extracted Values of D_{LAT} , D_{PAT} , k , and CFR

This is the same as output Q14.3.

Q6B.2 OUTPUT - Determination of D_{IN}

D_{IN} represents the total incoming defects (or defect density) resident in the equipment before screening. D_{IN} is calculated as the sum of the latent and patent defect content which are values extracted from the fallout analysis (activity Q14).

Q6B.3 OUTPUT - Determination of $D_{REMAINING}$

$D_{REMAINING}$ represents the total defects (or defect density) remaining in the equipment after screening. $D_{REMAINING}$ is calculated as the difference of incoming defects and number of defects removed, where the number of defects removed is found through the fallout analysis (activity Q14). The value of $D_{REMAINING}$ is later used to determine whether screen strength should be increased or decreased.

Q6B.4 OUTPUT - Required Action to Reduce D_{IN}

D_{IN} is reduced only through corrective actions which reduce further incoming defect density and thereby improve process capability. The observed value of D_{IN} is compared to the planning value to determine whether or not corrective action is necessary.

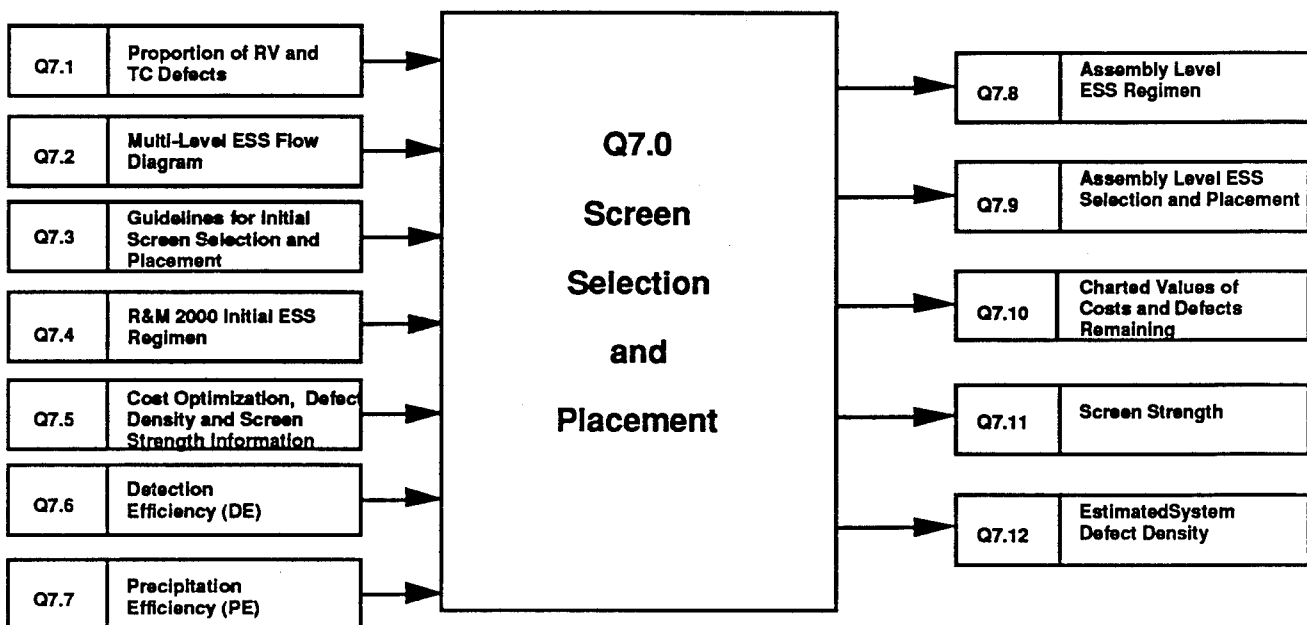

Figure 2.27. Activity Q7.0: Screen Selection and Placement

Q7.0 ACTIVITY - Screen Selection and Placement

This is an iterative process which begins by initially selecting assembly and system level ESS placement and regimen based on recommended handbook (Mil-Hdbk-344) tables and experience with similar equipment.

Q7.1 INPUT - Proportion of RV and TC Defects

A ratio must be determined based on prior experience or engineering judgment. Mil-Hdbk-344A recommends using a starting ratio of 80% TC and 20% RV.

Q7.2 INPUT - Multi-level ESS Flow Diagram

This is the same as output Q5.6.

Q7.3 INPUT - Guidelines for Initial Screen Selection and Placement

Table 4.4 in Mil-Hdbk-344A is recommended as a guide in selecting and placing screens for a starting regimen.

Q7.4 INPUT - R & M 2000 Initial ESS Regimen

Screen types, parameters and placements recommended as initial regimen are outlined in Table 4.5 in Mil-Hdbk-344A.

Q7.5 INPUT - Cost Optimization, Defect Density, and Screen Strength Information

This information comes from Activity Q11, "Optimization", Activity Q6A.0, "Generate Initial Estimates Of Defect Density", Activity Q6B.0, "Refine Estimates Of Defect Density", and Activity Q8B.0, "Refine Estimates Of Screen Strength".

Q7.6 INPUT - Detection Efficiency (DE)

Detection Efficiency of each assembly should be determined in accordance with Mil-Hdbk-344A, step 2 of Procedure C.

Q7.7 INPUT - Precipitation Efficiency

Precipitation Efficiency of each assembly should be determined by Mil-Hdbk-344A, Tables 5.14 - 5.17 or step 1 of Procedure C.

Q7.8 OUTPUT - Assembly Level ESS Regimen

This includes the determination and placement of RV and TC ESS parameters for each assembly and subassembly. For RV a GRMS value and vibration duration and for TC a temp. range, rate of change and number of cycles are required.

Q7.9 OUTPUT - Assembly Level ESS Selection & Placement

RV and TC screens are placed at various locations in the ESS model. Guidance for initial selection and placement comes from inputs Q7.3 and Q7.4. Modification and improvement of selection and placement comes after data is available as mentioned in input Q7.5.

Q7.10 OUTPUT - Charted Values of Costs and Defects Remaining and Removed

The multi-level ESS flow diagram is modified by the addition of cost and remaining and removed defect values. The handbook provide procedures to compute these values. The values are a function of defect density and screen strength.

Q7.11 OUTPUT - Screen Strength

Screen strength of each assembly is calculated by multiplying precipitation efficiency (PE) by detection efficiency (DE).

Q7.12 OUTPUT - Estimated System Defect Density

This is an estimated value of system defect density at factory stress level before ESS.

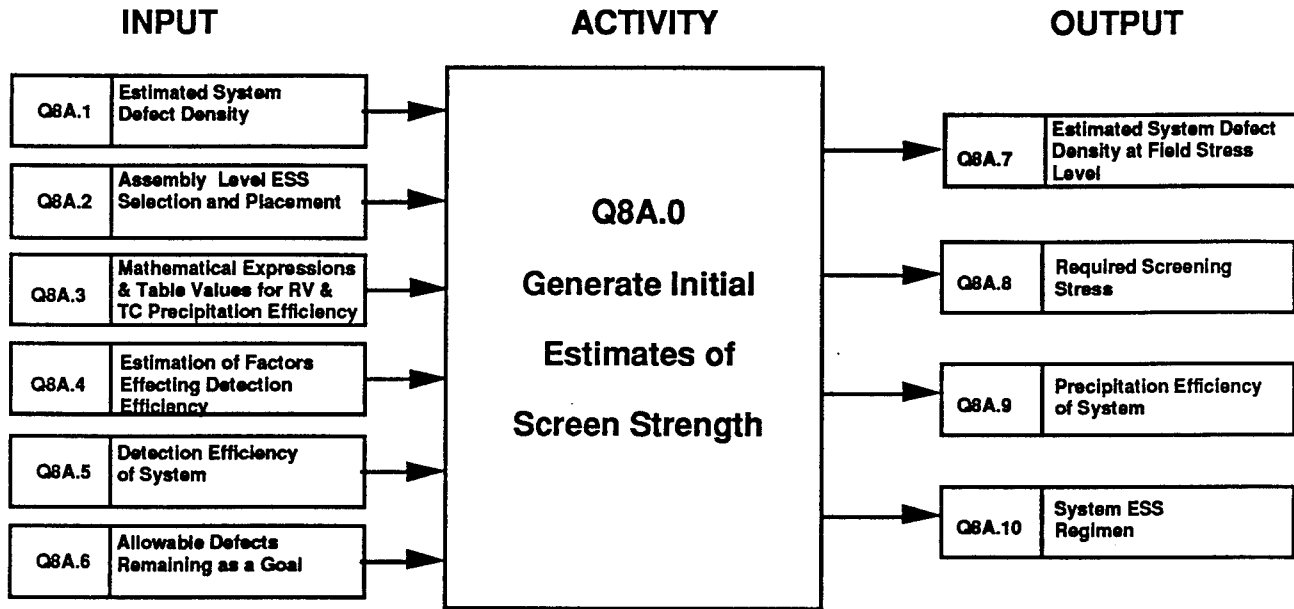

Figure 2.28A. Activity Q8A.0: Generate Initial Estimates of Screen Strength

Q8A.1 ACTIVITY - Estimated System Defect Density

This is the same as output Q7.12.

Q8A.2 INPUT - Assembly Level ESS Selection And Placement

This is the same as output Q7.9.

Q8A.3 INPUT - Mathematical Expressions & Table Values for RV & TC Precipitation Efficiency

Precipitation efficiency is defined as a measure of the capability of a screen to precipitate latent defects to failure. Mil-Hdbk-344A provides equations and tables for computing values of precipitation efficiency based on number of cycles, temperature rate of change and temperature range for temperature cycling and gRMS for random vibration.

Q8A.4 INPUT - Estimation of Factors Effecting Detection Efficiency

Detection efficiency is a measure of the capability of detecting a precipitated latent defect. Mil-Hdbk-344A provides factors and equations for computing detection efficiency based on type of testing performed and conditions during test.

Q8A.5 INPUT - Detection Efficiency of System

This is the same as input Q7.6.

Q8A.6 INPUT - Allowable Defects Remaining as a Goal

This is the same as output Q5.5.

Q8A.7 OUTPUT - Estimated System Defect Density at Field Stress Level

This is estimated by multiplying output Q6A.7 by output Q7.10 (input Q8A.1)

Q8A.8 OUTPUT - Required Screening Stress

This value is estimated by the following formula:

$$\text{Required Screening Stress} = \frac{\text{output Q8A.7} - \text{output Q8A.6}}{\text{output Q8A.7}}$$

Q8A.9 OUTPUT - Precipitation Efficiency Of System

A value in terms of probability is determined for the system. It is obtained by dividing required screening stress (output Q8A.8) by detection efficiency (input Q8A.6).

Q8A.10 OUTPUT - System ESS Regimen

This involves the determination and placement of RV and TC ESS throughout the system.

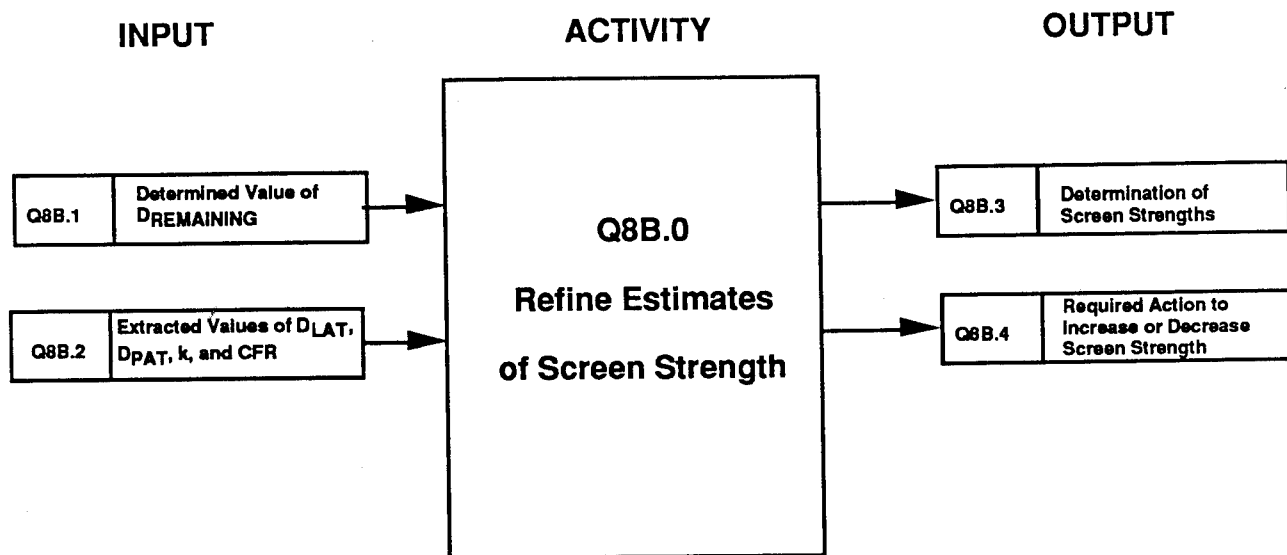

Figure 2.28B Activity Q8B.0: Refine Estimates of Screen Strength

Q8B.0 ACTIVITY - Refine Estimates of Screen Strength

This activity involves the computation of screen strength from the analysis of fallout data. The observed value of D_{REMAINING} is compared to the planning value to determine if screening strength should be increased or decreased. This activity takes place after activities Q14 "Fallout Analysis" and Q15 "Monitor and Control".

Q8B.1 INPUT - Determined Value of D_{REMAINING}

This is the same as output Q6B.3 This is the "observed" value of D_{REMAINING}.

Q8B.2 INPUT - Extracted Values of D_{LAT}, D_{PAT}, k, and CFR

This is the same as output Q14.3.

Q8B.3 Determination of Screen Strengths

Screen strength is the probability that a specific screen will precipitate a latent defect to failure and detect it by test, given that a latent defect susceptible to the screen is present. It is the product of precipitation efficiency and detection efficiency. Equations are provided within Mil-Hdbk-344A to calculate screen strength from the parameters listed in input Q8B.2.

Q8B.4 Required Action to Increase or Decrease Screen Strength

Upon determining screen strength, the observed value is compared with the planning value. The same comparison is made with $D_{REMAINING}$. If necessary, screen strength is increased by changing the screen type, stress levels or duration of the screen and by increasing the thoroughness of tests which are performed in conjunction with the screen.

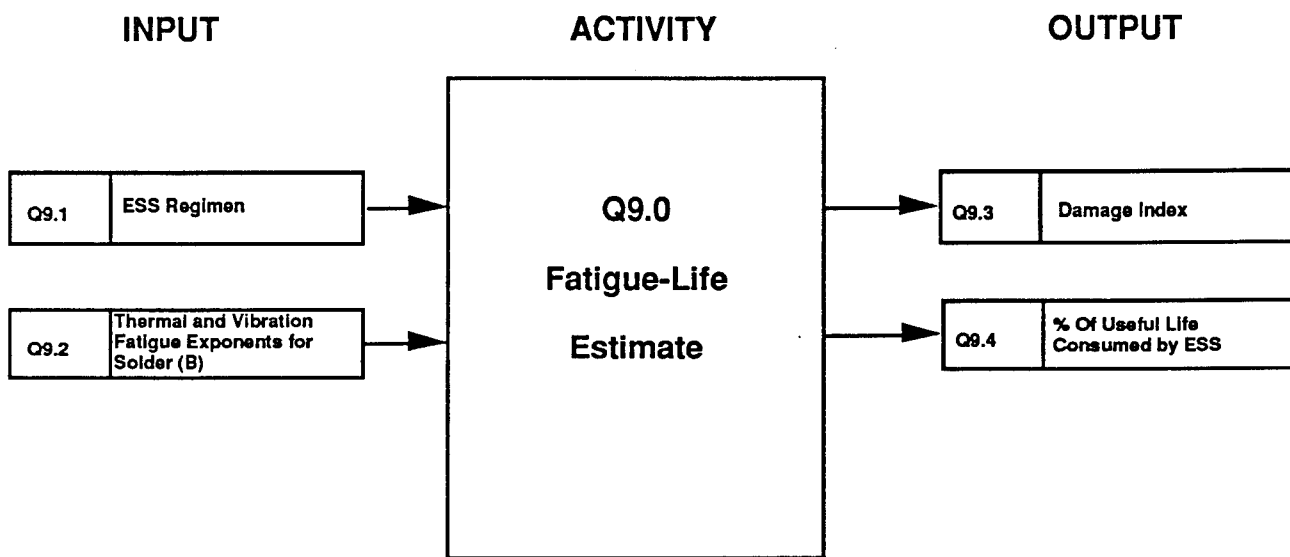

Figure 2.29. Activity Q9.0: Fatigue-Life Estimate

Q9.0 ACTIVITY - Fatigue-Life Estimate

This activity attempts to estimate the fatigue-life and to ensure that ESS is not too stressful and does not consume too much of the useful (fatigue) life. This is the same as Procedure A4 of Mil-Hdbk-344A.

Q9.1 INPUT - ESS Regimen

This is the same as output Q8A.10.

Q9.2 INPUT - Thermal and Vibration Fatigue Exponents for Solder (B)

B = 2.5 - thermal fatigue exponent for solder

B = 6.4 - vibration fatigue exponent for solder

The source of these values is Mil-Hdbk-344A, procedure A4.

Q9.3 OUTPUT - Damage Index (D)

Damage index is calculated separately for random vibration and thermal cycling. The equation used to compute damage index is $D = NS^B$. The same equation is used to compute damage index for life (D_L) and for ESS (D_E). For temperature cycling, N = number of cycles, S = temperature range in degrees Celsius and $B = 2.5$. For random vibration, N = duration of vibration in hours or minutes, S - G_{RMS} vibration level and $B = 6.4$.

Q9.4 OUTPUT - % of Useful Life Consumed by ESS

This is estimated by dividing the damage index for ESS by the damage index for life.

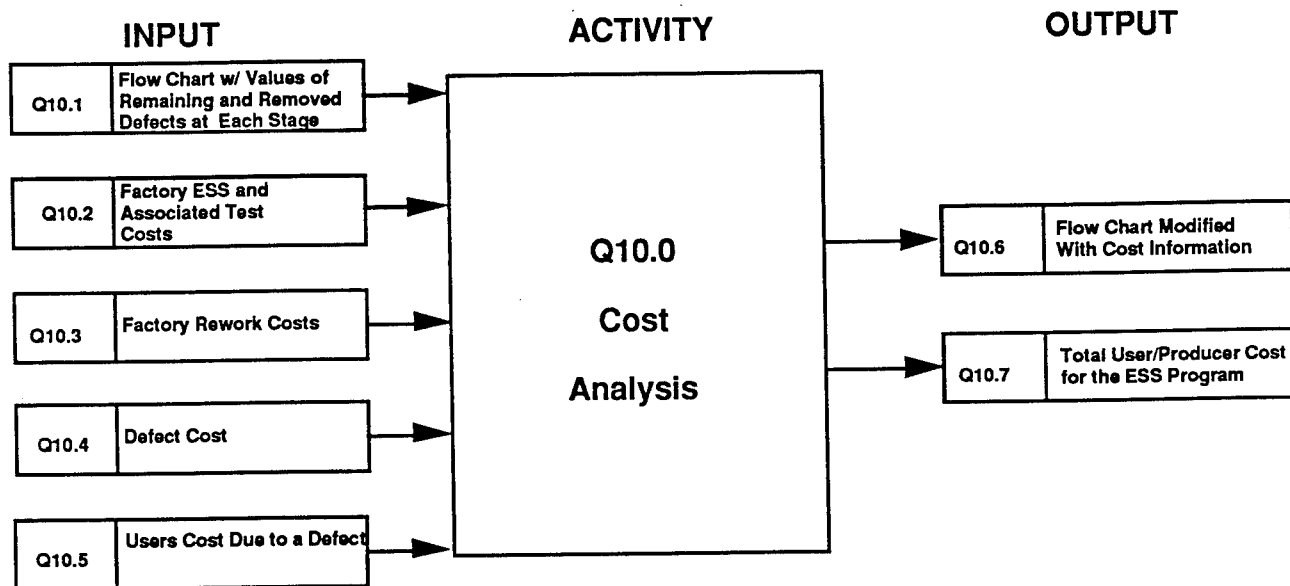

Figure 2.30. Activity Q10.0: Cost Analysis

Q10.0 ACTIVITY - Cost Analysis

This activity involves determining the cost of the ESS program. Cost analysis data is used to modify the program to save money.

Q10.1 INPUT - Flow Chart with Values of Remaining and Removed Defects at Each Stage

This is the same as output Q7.10.

Q10.2 INPUT - Factory ESS and Associated Test Costs

This includes the cost of all factory ESS and any associated testing which basically consists of equipment and labor costs.

Q10.3 INPUT - Factory Rework Costs

This is the average total cost to repair defects at each stage including diagnostics, rework/repair, retest, repeat ESS, and data recording costs.

Q10.4 INPUT - Defect Cost

The defect cost is determined by multiplying the number of defects at each stage by the cost to repair each defect.

Q10.5 INPUT - Users Cost Due to a Defect

This cost treats the field as an extension of the ESS test flow by determining the users cost associated with a defect.

Q10.6 OUTPUT - Flow Chart Modified With Cost Information

The flow chart consisting of values of defects remaining and removed is modified at this point to include the cost associated with screening.

Q10.7 OUTPUT - Total User/Producer Cost for the ESS Program

The total user/producer cost is the sum of inputs Q10.2, Q10.3, Q10.4, and Q10.5.

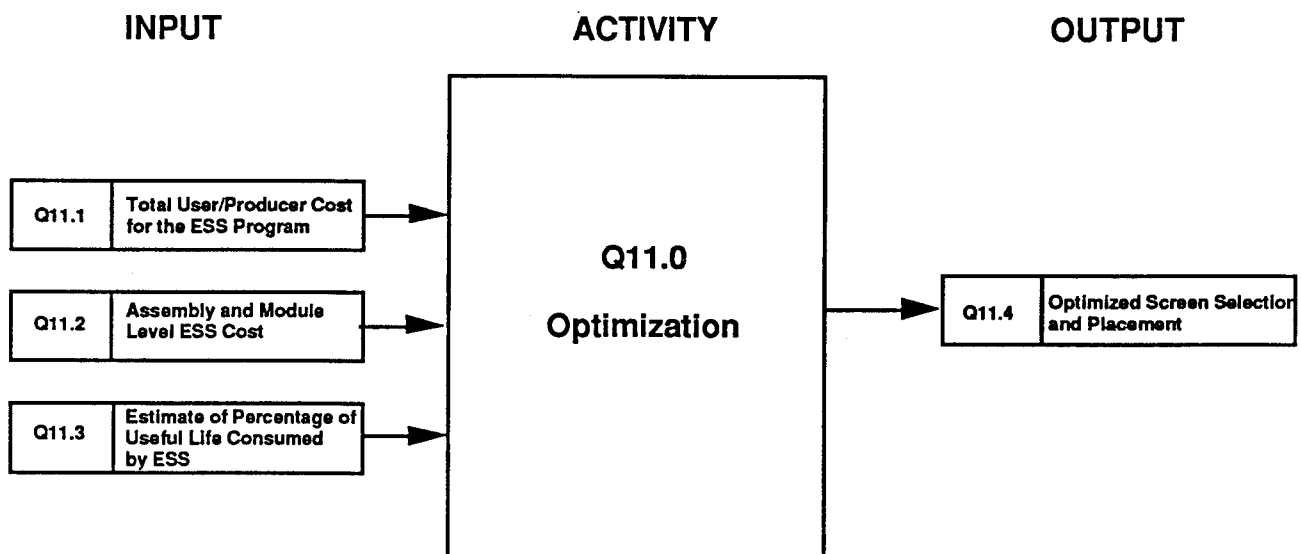

Figure 2.31. Activity Q11.0: Optimization

Q11.0 ACTIVITY - Optimization

This activity involves an optimization of the screen selection and placement based on cost and fatigue life estimation.

Q11.1 INPUT - Total User/Producer Cost for the ESS Program

This is the same as output Q10.7.

Q11.2 INPUT - Assembly and Module Level ESS Cost

The cost associated with system level ESS is determined for all assemblies and modules. Assemblies and modules with high system level ESS cost are identified.

Q11.3 INPUT - Estimate of Percentage of Useful Life Consumed by ESS

This is the same as output Q9.4.

Q11.4 OUTPUT - Optimized Screen Selection and Placement

For those assemblies and modules with high system level ESS cost a lower level ESS placement should be selected. The cost is then recalculated and mathematical verification that field reliability will be achieved is then made by using the modeling procedures in Mil-Hdbk-344A.

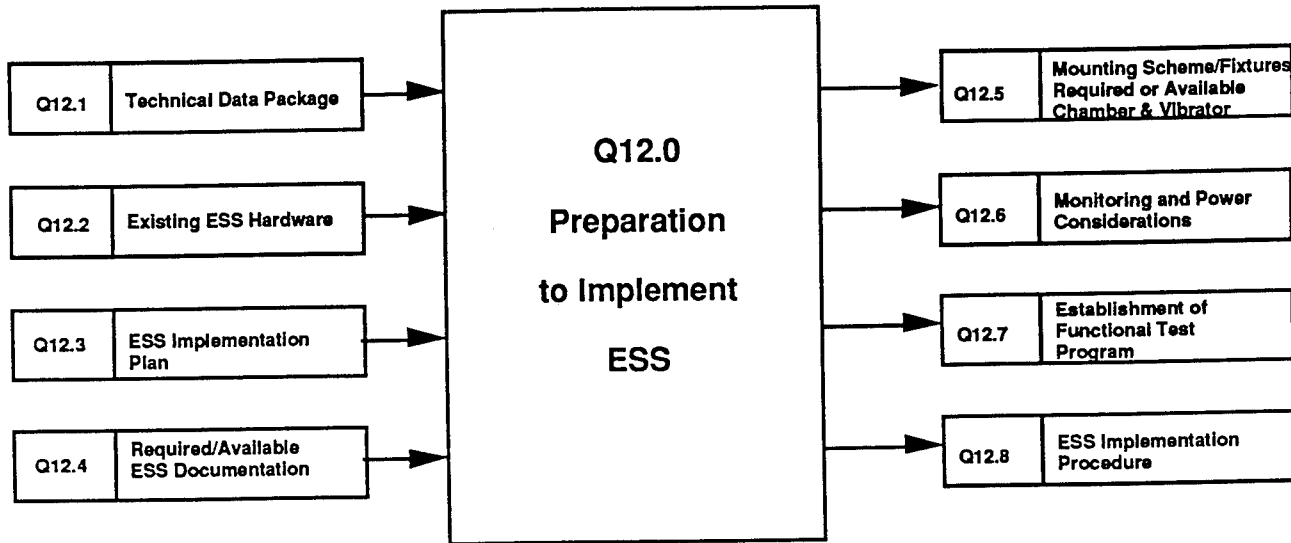

Figure 2.32. Activity Q12.0: Preparation to Implement ESS

Q12.0 ACTIVITY - Preparation to Implement ESS

This activity involves all final equipment and procedural preparation for actual production screening.

Q12.1 INPUT - Technical Data Package

The technical data package includes all documented information relative to the system/equipment to be screened. For example, specifications, drawings, test procedures, manufacturing instructions, etc.

Q12.2 INPUT - Existing ESS Hardware

Available ESS hardware including fixtures, chambers, vibrators, etc.

Q12.3 INPUT - ESS Implementation Plan

This is the same as output Q1.9.

Q12.4 INPUT - Required/Available ESS Documentation

This is the same as input Q1.4.

Q12.5 OUTPUT - Mounting Scheme/Fixtures, Required or Available Chamber & Vibrator

This is the same as output C6.6.

Q12.6 OUTPUT - Monitoring and Power Considerations

This is the same as output C6.7.

Q12.7 OUTPUT - Establishment of Functional Test program

This is the same as output C6.8.

Q12.8 OUTPUT - ESS Implementation Procedure

This includes a list of items to be screened, installation procedures for monitoring/test equipment, placement method of chamber and vibrator, and pre, post and functional ESS test procedures.

Q13.0 ACTIVITY - Production Screening - Same as activity C9.0.

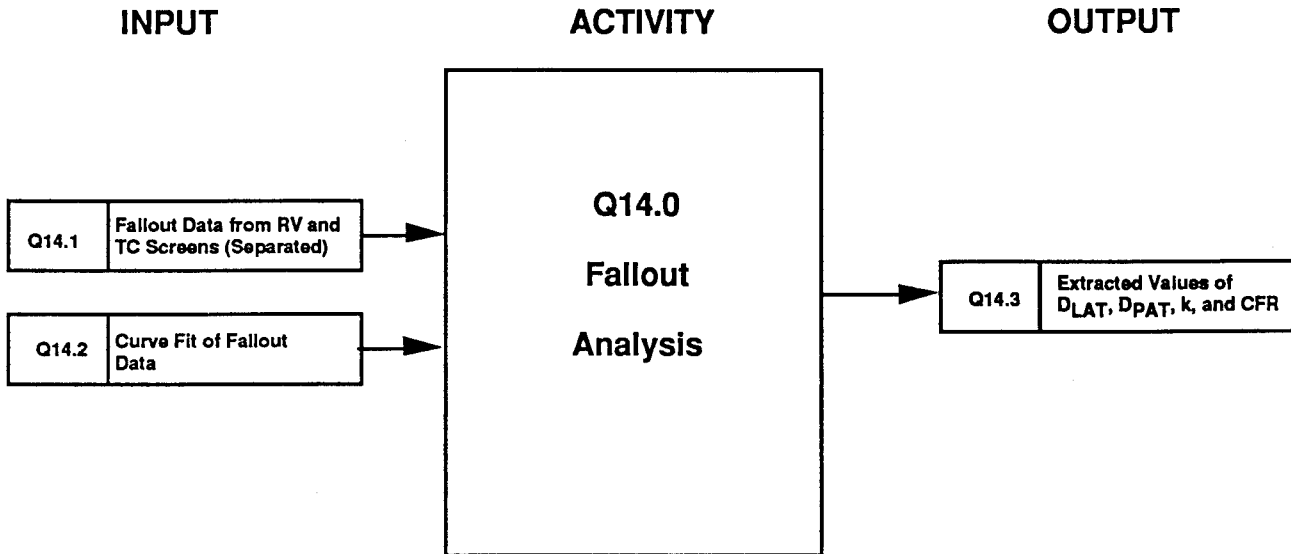

Figure 2.33. Activity Q14.0: Fallout Analysis

Q14.0 ACTIVITY - Fallout Analysis

This activity involves analysis of the fallout data to extract defect density values and other parameters for use in quantitatively modifying screening levels.

Q14.1 INPUT - Fallout Data from RV and TC Screens

The data required should be available from the FRACAS system. This includes fallout data from each type of environment (i.e., TC and RV).

Q14.2 INPUT - Curve Fit of Fallout Data

Fallout data is collected for each type of environment (i.e., temperature cycling, random vibration, etc.) separately and graphs should be prepared with the cumulative defects per system as the ordinate, and the stress duration as the abscissa.

Q14.3 OUTPUT - Extracted Values of D_{LAT} , D_{PAT} , k , and CFR

Mil-Hdbk-344A provides methods for extracting various required parameters. The parameters required include D_{PAT} - Patent Defect Density, D_{LAT} - Latent Defect Density, k - stress constant, and CFR - Constant Failure Rate. The parameters are later used to compute "observed" values of remaining and initial defect density, and screen strength.

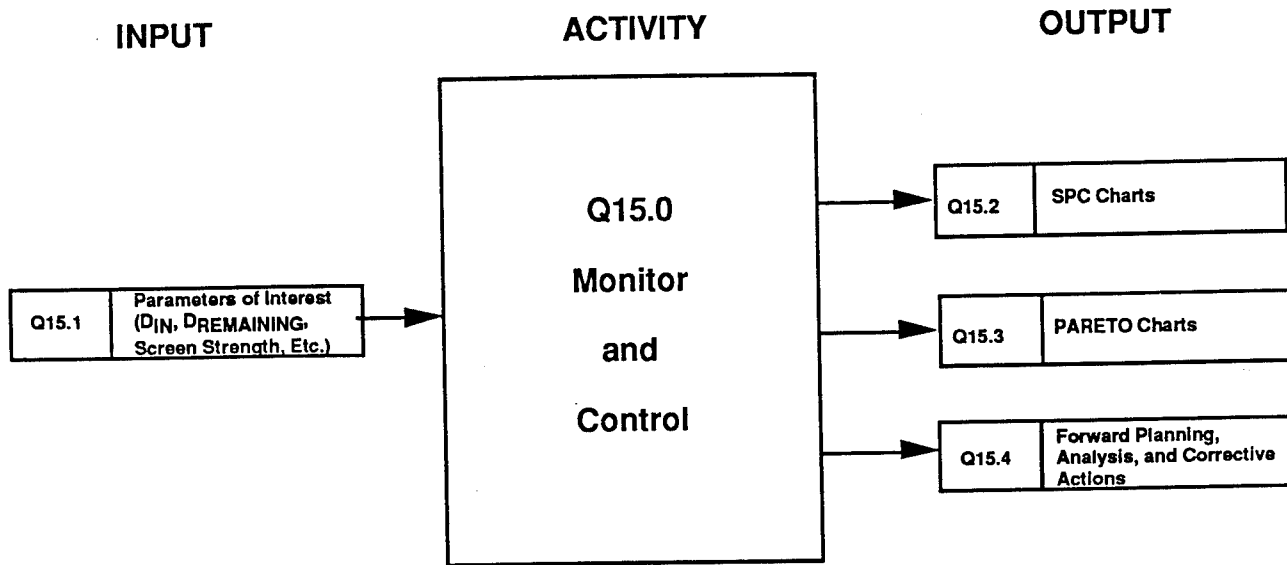

Figure 2.34 Activity Q15.0: Monitor and Control

Q15.0 ACTIVITY - Monitor and Control

This activity involves utilizing modified Statistical Process Control and PARETO Charts to monitor parameters of interest against established requirements.

Q15.1 INPUT - Parameters Of Interest (D_{IN} , $D_{REMAINING}$, Screen Strength, Etc.)

The parameters of interest are determined (and defined) in Activities Q14.0, Q6B.0, and Q8B.0.

Q15.2 OUTPUT - SPC Charts

Statistical Process Control charts are used to display goals and compare actual results to the goals. When using SPC charts to monitor values of defect density, the charts are different than conventional SPC charts in that the parameter of interest should be improving with time, thus making it necessary to use regression analysis.

Q15.3 PARETO Charts

As a supplement to SPC charts it is sometimes useful to generate a PARETO chart to display a breakdown of failure causes.

Q15.4 Forward Planning, Analysis, and Corrective Actions

Out of control conditions and failure causes should be examined to compare requirements with any variations. The amount of resources required to understand and resolve problems should be determined along with the comparison.

3.0 ESS Guidebook Process Descriptions

This Chapter provides process descriptions of the following ESS guidebooks:

- IES ESS Guidelines For Assemblies
- Tri-Service ESS Guidelines
- Navy Manufacturing Screening Program
- Mil-Hdbk-344A, ESS of Electronic Equipment
- TE000-AB-GTP-020A, ESS Requirements And Application Manual For Navy Electronic Equipment

Also provided are short summaries of eight other ESS guidebooks.

3.1 Institute of Environmental Sciences (IES) Environmental Stress Screening Guidelines For Assemblies (Dated March 1990)

3.1.1 Discussion of IES Environmental Stress Screening Guidelines For Assemblies

The IES ESS Guidelines document was prepared by the ESSEH Technical Committee Working Group. It contains guidance in the areas of ESS program management, project engineering, and some contracting. Major sections of the book are devoted to random vibration and thermal cycling stress screening characteristics development. For random vibration the following five methods are provided to generate an initial starting regimen for RV screening: Development of Input Spectrum using Flaw Precipitation Threshold; Development of Screening Level From Overall Internal Response Levels; Development of Screening Level Through Step-Stress Tests; Development of Screening Level from Fault Replication Tests; and Heritage Screen. A vibration survey is required for the first two methods. Details are provided in a separate section on how to conduct a vibration survey. For thermal cycling, thermal survey guidelines are provided for developing an initial thermal cycling regimen. The guidebook also provides a cost-benefit analysis procedure, quantitative tailoring methods, and information useful for ESS process control. A format for an ESS statement of work is also included. The level of assembly addressed in the guidelines document is from the printed wiring assembly up to the system level. Part level ESS guidance is not included. The document is very tutorial in nature in providing details on various ESS topics and definitions.

3.1.2 IES ESS Guidelines Process

Figure 3.1 illustrates the top level activities flow of the IES ESS Guidelines document. Figures 3.2 through 3.11 illustrate the individual activities of the process along with their inputs and outputs. Activity and input and output descriptions follow each illustration.

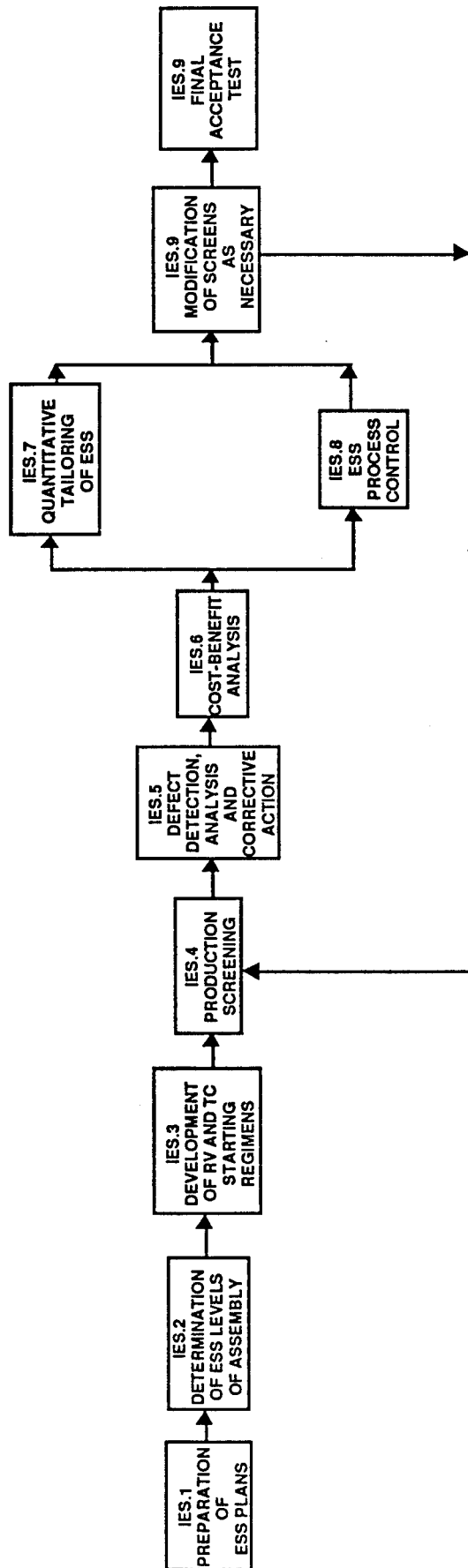

Figure 3.1. Institute of Environmental Sciences ESS Guidelines Top Level Activities Flow Diagram.

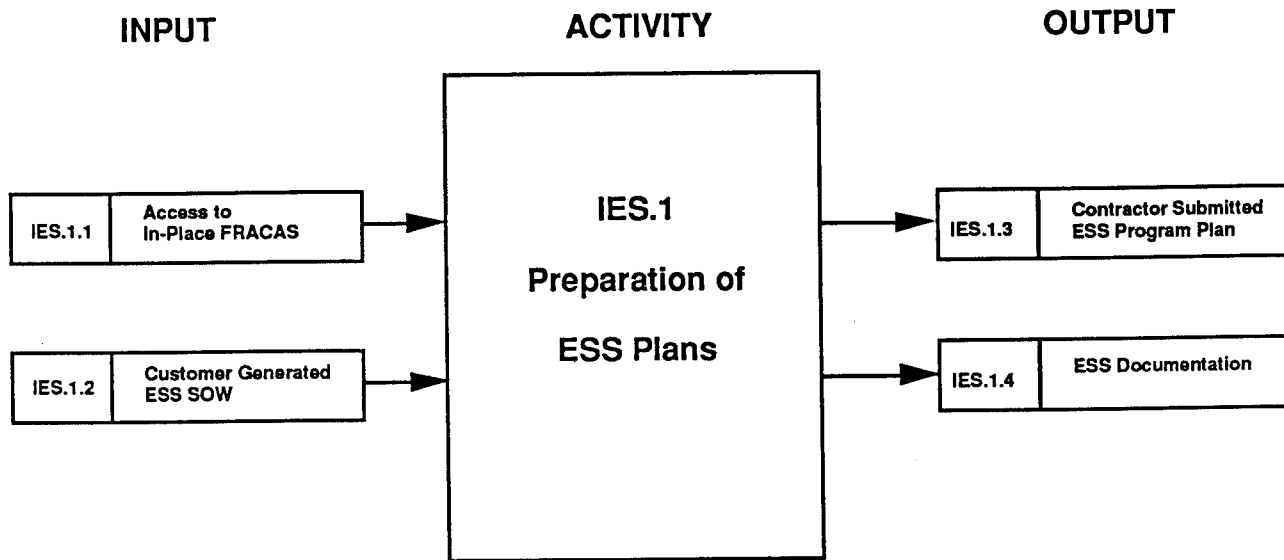

Figure 3.2. Activity IES.1: Preparation of ESS Plans

IES.1 ACTIVITY - Preparation of ESS Plans

The guidebook provides management guidance useful to both the government and the contractor. A statement of work format is provided as well as an entire section on Program Management.

IES.1.1 INPUT - Access to In-Place FRACAS

An in-place failure reporting analysis and corrective action system is recommended to aid in the improvement of the manufacturing process as a result of screening.

IES.1.2 INPUT - Customer Generated ESS SOW

A government (or other customer, e.g. prime contractor) generated statement of work specifies the ESS processes to be followed. A sample ESS SOW is found in the IES guidebook.

IES.1.3 OUTPUT - Contractor Submitted ESS Program Plan

The IES guidebook, in its sample SOW, requires the contractor to submit a Program Plan to document cost effective ESS methods and procedures to implement the ESS program.

IES.1.4 OUTPUT - ESS Documentation

The IES guidebook also requires in its sample SOW, that the contractor submit detailed ESS documentation. This is to include all planned procedures, schedule, ESS starting profiles for all equipment to be screened, etc.

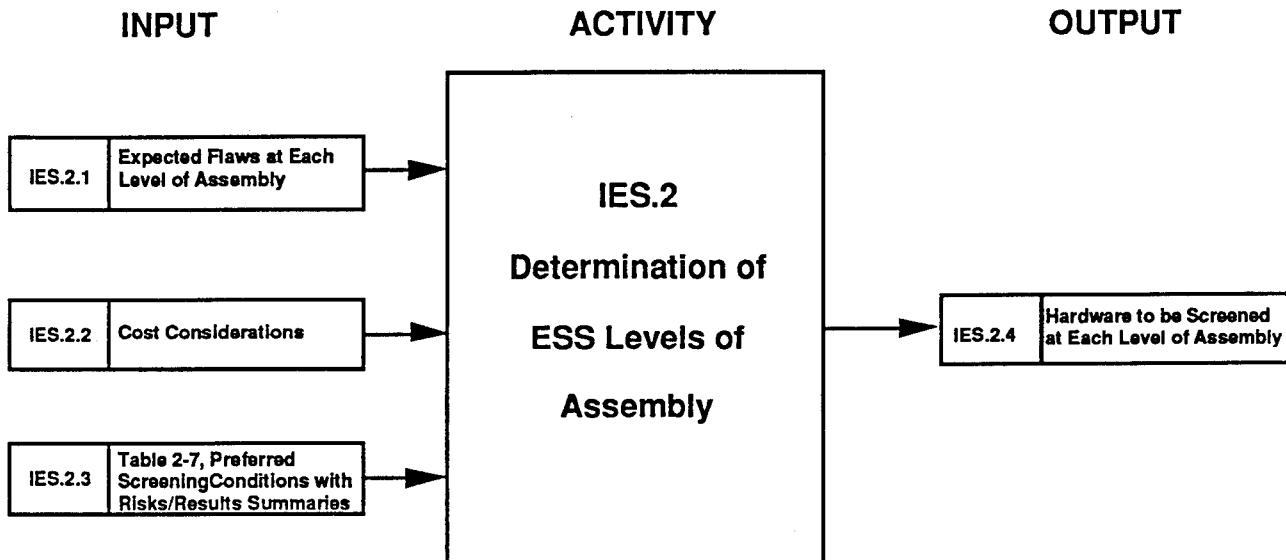

Figure 3.3. Activity IES.2: Determination of ESS Levels of Assembly

IES.2 ACTIVITY - Determination of ESS Levels of Assembly

This activity involves determining at which levels ESS should be conducted for a given development. PWA, unit, and system are the three levels delineated in the guidebook. When making the decision at which levels to screen at, a number of important variables should be taken into account. These include technical effectiveness, cost effectiveness, and index of failure detectability.

IES.2.1 INPUT - Expected Flaws at Each Level of Assembly

An understanding of the population of flaws to be expected at the various levels contributes greatly to the determination of ESS levels of assembly.

IES.2.2 INPUT - Cost Considerations

The cost effectiveness of screening is an important consideration when determining levels of assembly.

IES.2.3 INPUT - Table 2.7, Preferred Screening Conditions with Risks/Results Summaries

The IES guidebook provides a table containing information relative to cost, risks and results for screening at various levels of assembly and equipment conditions. The table is useful for initial planning of ESS levels of assembly.

IES.2.4 OUTPUT - Hardware to be Screened at Each Level of Assembly

The choice of level of assembly for both random vibration and thermal cycling screens is the main output of activity IES.2.

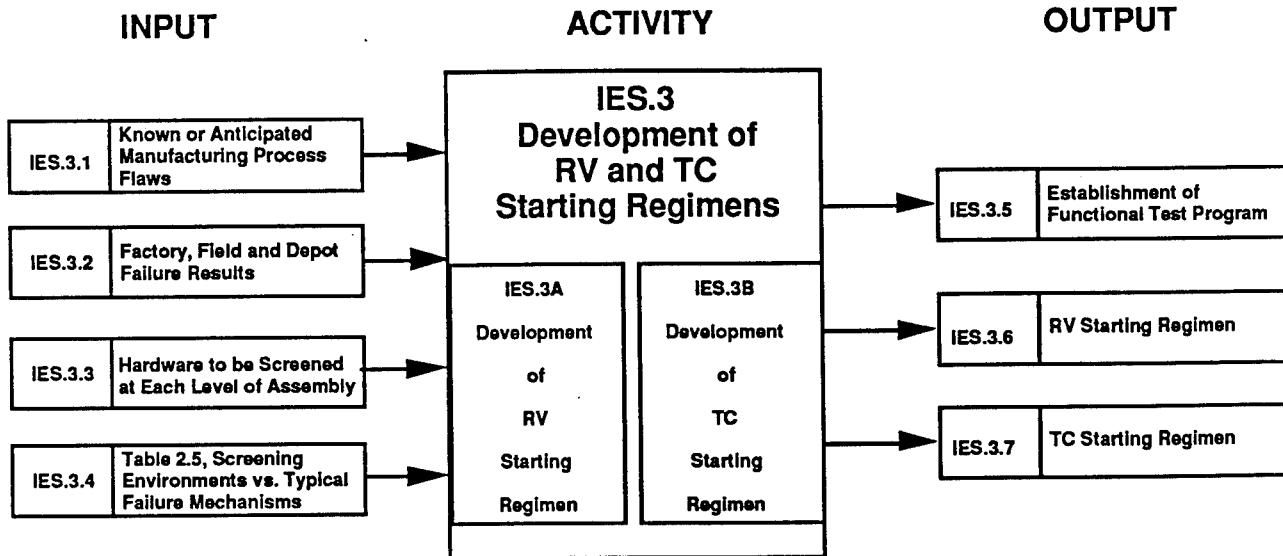

Figure 3.4. Activity IES.3: Development of RV and TC Starting Regimens

IES.3 ACTIVITY - Development of RV and TC Starting Regimens

A major portion of the IES guidebook is devoted to this activity. The activity is broken down into two sub activities as shown. The sub activities are: Development of Random Vibration Starting Regimen and Development of Thermal Cycling Starting Regimen. Flow diagrams for the sub activities are shown below. Inputs to activity IES.3 apply to both sub activities.

IES.3.1 INPUT - Known or Anticipated Manufacturing Process Flaws

The choice of RV and TC screens selected is heavily dependent on known or anticipated flaws. Different types of screening scenarios are more effective than others depending on the flaw type anticipated.

IES.3.2 INPUT - Factory, Field and Depot Failure Results

The study of factory, field and depot failures is necessary to determine not only what flaws are anticipated and how to structure the screen, but also to determine how screens should be modified if they are too weak or too strong.

IES.3.3 INPUT - Hardware to be Screened at Each Level of Assembly

This is the same as output IES.2.4.

IES.3.4 INPUT - Table 2.5, Screening Environments vs. Typical Failure Mechanisms

The guidebook provides Table 2.5 which lists various failure types under three columns: thermal cycling, vibration, and thermal and/or vibration. It is important to understand the various flaw types that can be precipitated by the two different types of ESS.

IES.3.5 OUTPUT - Establishment of Functional Test Program

The purpose of the test program established is to assure that the various flaws precipitated by ESS are detected.

IES.3.6 OUTPUT - Random Vibration Starting Regimen

See output IES.3A.6 below.

IES.3.7 OUTPUT - Thermal Cycling Starting Regimen

See output IES.3B.4 below.

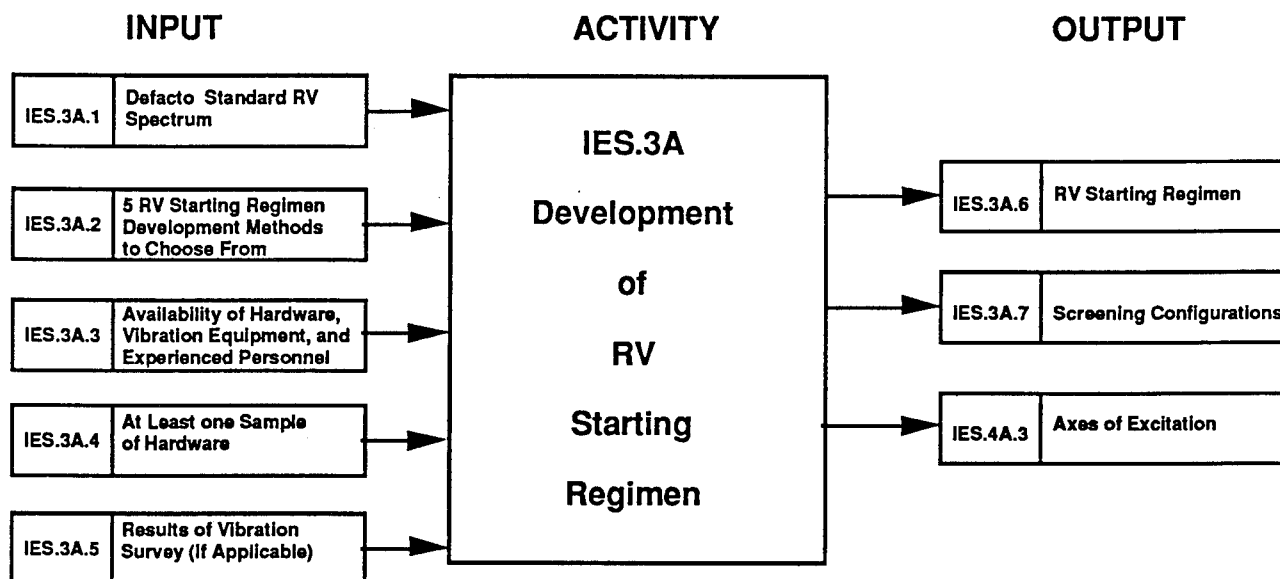

Figure 3.5. Activity IES.3A: Development of Random Vibration Starting Regimen

IES.3A ACTIVITY - Development of Random Vibration Starting Regimen

The IES guidebook contains detailed guidelines on how to generate a starting regimen for random vibration.

IES.3A.1 INPUT - Defacto Standard RV Spectrum

Several references suggest using as a starting RV spectrum: 6 g_{RMS} consisting of .04 g²/Hz with a frequency range of 20 - 2000 Hz and 3 dB/octave rolloffs from 80 to 20 Hz and 350 to 2000 Hz. The IES guidebook expresses caution in using this spectrum with certain equipment types.

IES.3A.2 INPUT - 5 RV Starting Regimen Development Methods to Choose From

The IES guidebook provides guidance on the use of the following methods: 1. Development of Input Spectrum Using Flaw Precipitation Threshold; 2. Development of Overall Screening Level Using Overall Internal Response Levels; 3. Development Of Overall Screening Level Through Step-Stress Tests; 4. Development Of Overall Screening Level Through Fault-Replication Tests; 5. Heritage Screens.

IES.3A.3 INPUT - Availability of Hardware, Vibration Equipment, and Experienced Personnel

This information is used to help decide on which of the five methods mentioned in input IES.3A.2 should be used.

IES.3A.4 INPUT - At Least One Sample of Hardware

A sample of hardware identical to that to be screened is needed along with any necessary functional test equipment.

IES.3A.5 INPUT - Results of Vibration Survey (If Applicable)

A vibration survey is used to measure the response of the equipment when exposed to vibration levels less severe than the actual screen. Appendix B1 of the IES guidebook provides detailed guidelines on how to conduct a vibration survey. The results of the vibration survey are used with the first two of the RV starting regimen development methods described in input IES.3A.2 above.

IES.3A.6 OUTPUT - Random Vibration Starting Regimen

Characteristics of an RV starting regimen include the spectrum which consists of a gRMS value that is also represented graphically as power spectral density (g^2/Hz) on the ordinate and frequency (Hz) on the abscissa. The graph will show rollofts in dB/octave. Screen duration must also be determined.

IES.3A.7 OUTPUT - Screening Configurations

This includes fixture setups/installation required to stress out expected flaws.

IES.3A.8 OUTPUT - Axes of Excitation

A determination of the number of axes of excitation is required. One, two or three sequential axes will usually be required. A historical base of flaw detection versus the number of axes should be kept.

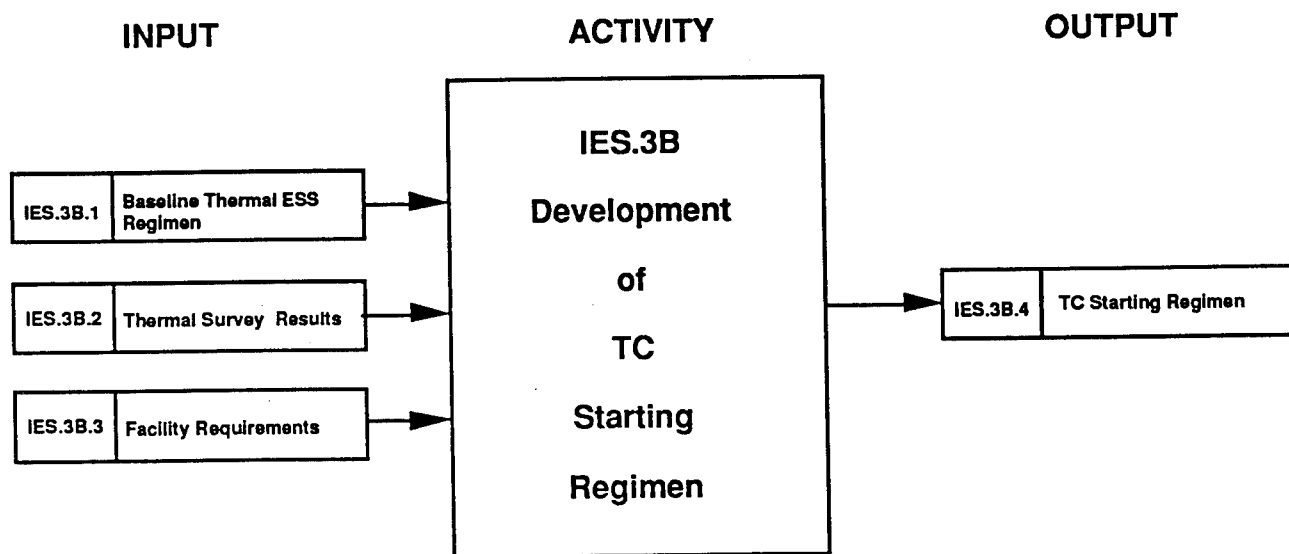

Figure 3.6. Activity IES.3B: Development of Thermal Cycling Starting Regimen

IES.3B ACTIVITY - Development of Thermal Cycling Starting Regimen

The IES guidebook contains detailed guidelines on how to develop an initial thermal cycling starting regimen.

IES.3B.1 INPUT - Baseline Thermal ESS Regimen

A baseline regimen is provided for those having no data on similar items. The table outlines recommended temperature ranges, rates of change, stabilization criteria, soak times, number of cycles, and equipment conditions. The information is provided for PWA, unit, and system levels of assembly.

IES.3B.2 INPUT - Thermal Survey Results

A thermal survey measures the thermal response during experimental temperature cycling of the equipment intended for TC ESS. The survey results are helpful in setting up the initial thermal cycling regimen. The IES guidebook contains detailed guidelines on how to conduct a thermal survey.

IES.3B.3 INPUT - Facility Requirements

A chamber is required with adequate heating and cooling capacity as well as chamber air speed fast enough to produce the required temperature rate of change.

IES.3B.4 OUTPUT - Temperature Cycling Starting Regimen

The TC starting regimen includes the following characteristics: number of cycles, for each cycle the high and low temperature, the temperature rate of change, the dwell times at the high and low temperatures, whether the equipment is powered or unpowered and monitored or unmonitored.

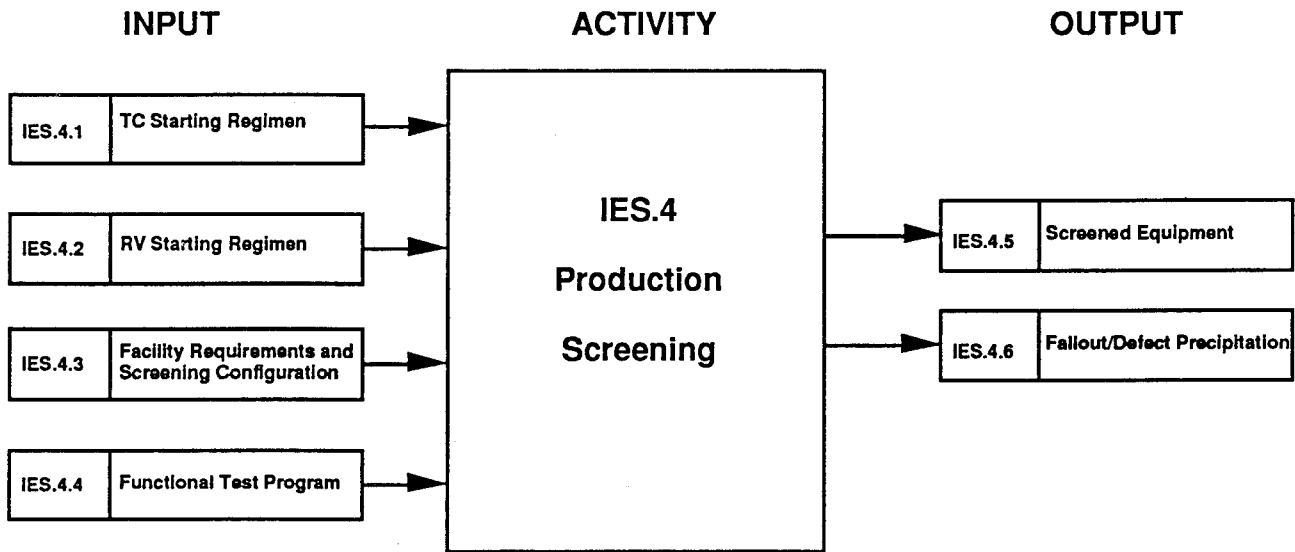

Figure 3.7. Activity IES.4: Production Screening

IES.4 ACTIVITY - Production Screening

This activity involves the actual screening of production hardware.

IES.4.1 INPUT - TC Starting Regimen

This is the same as output IES.3B.4.

IES.4.2 INPUT - RV Starting Regimen

This is the same as output IES.3A.6.

IES.4.3 INPUT - Facility Requirements and Screening Configuration
 All requirements for both shakers and thermal chambers must be met at this time. The fixture setup and installation requirements determined in output IES.3A.6 must also be addressed.

IES.4.4 INPUT - Functional Test Requirement
 This is the same as Output IES.3.5.

IES.4.5 OUTPUT - Screened Equipment
 The main output of the production screening activity is the screened equipment.

IES.4.6 OUTPUT - Fallout/Defect Precipitation
 This includes all defects precipitated as a result of screening.

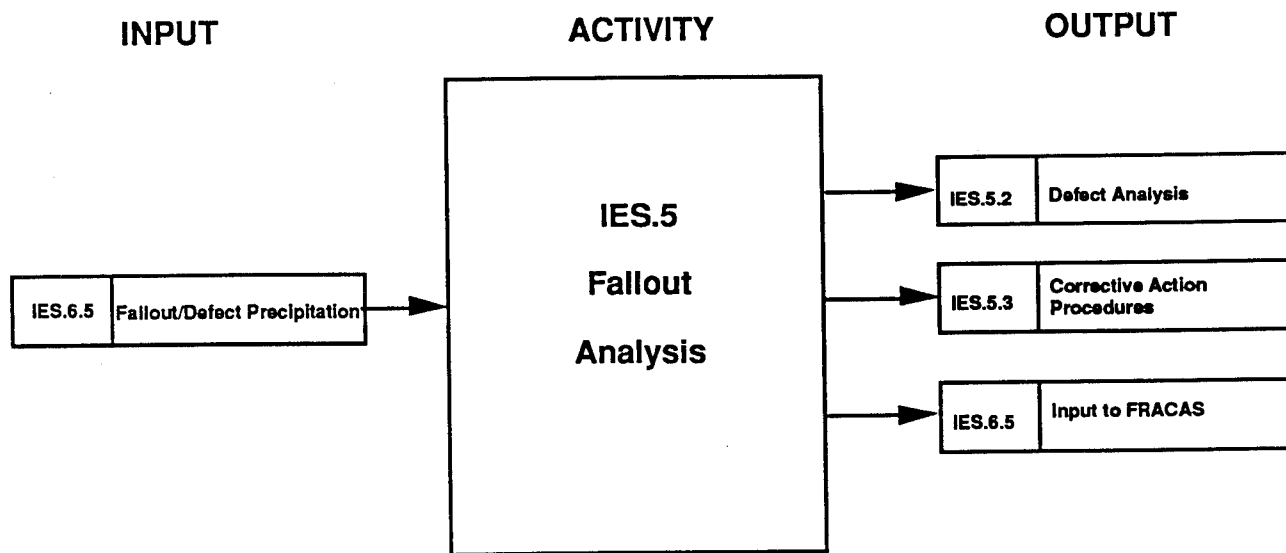

Figure 3.8. Activity IES.5: Fallout Analysis

IES.5 ACTIVITY - Fallout Analysis

This activity involves an assessment of the flaw types to assure feedback and a positive effect on the manufacturing process.

IES.5.1 INPUT - Fallout/Defect Precipitation
 This is the same as output IES.4.6.

IES.5.2 OUTPUT - Defect Analysis
 An analysis of all defects is necessary to determine corrective actions for improvement of the manufacturing process.

IES.5.3 OUTPUT - Corrective Action Procedures
 This includes reporting back to manufacturing and anyone else responsible for continuous improvement of the manufacturing process as a result of fallout analysis.

IES.5.4 OUTPUT - Input to FRACAS
 All failure data are to be made available to the in-place FRACAS system.

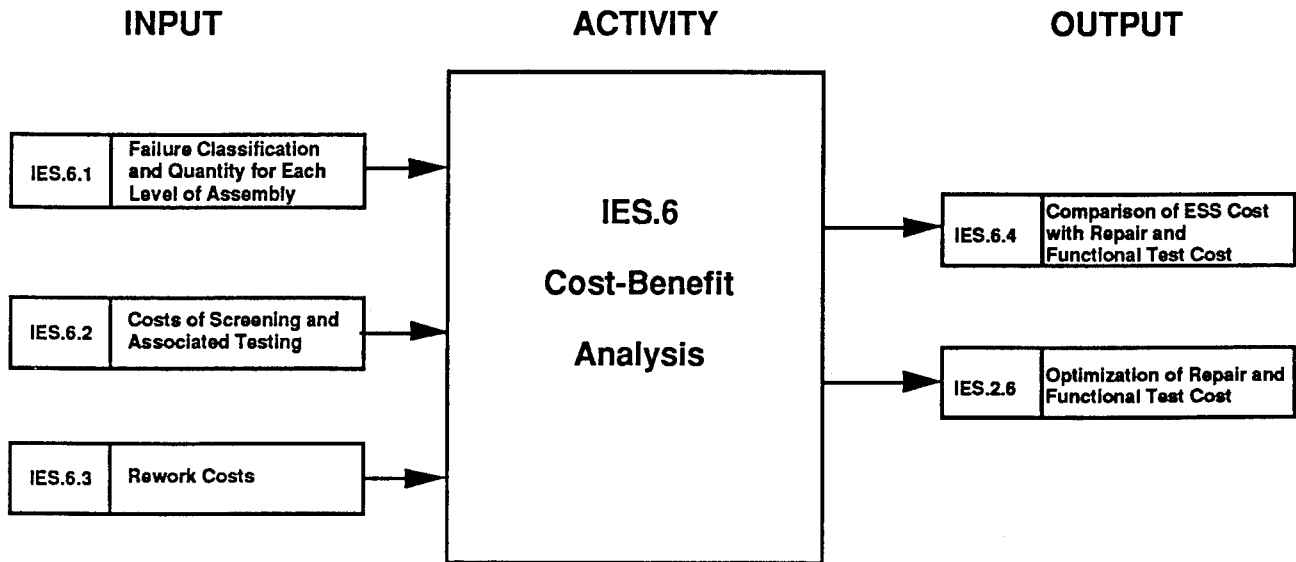

Figure 3.9. Activity IES.6: Cost-Benefit Analysis

IES.6 ACTIVITY - Cost-Benefit Analysis

The IES document provides guidance on how to conduct a cost-benefit analysis to optimize repair and test costs against required levels of ESS. The cost analysis can be accomplished through use of a personal computer spreadsheet program.

IES.6.1 INPUT - Failure Classification and Quantity for Each Level of Assembly

For the module, unit, and system levels of assembly, failure descriptions and flaws precipitated through pre-screen testing, screening, and post-screening are tabulated.

IES.6.2 INPUT - Costs of Screening and Associated Testing

An input to the cost-benefit analysis is the cost associated with screening and the functional testing conducted subsequent to screening.

IES.6.3 INPUT - Rework Costs

Costs associated with both part and non-part rework are used to compute an overall total rework cost for each screen and functional test at each level of assembly.

IES.6.4 OUTPUT - Comparison of ESS Cost with Repair and Functional Test Cost

The main output of the cost-benefit analysis a comparison of the cost of screening and functional test with those costs associated with rework and repair at each level of assembly.

IES.6.5 OUTPUT - Optimization of Repair and Functional Test Cost

This is the end result of the cost-benefit analysis.

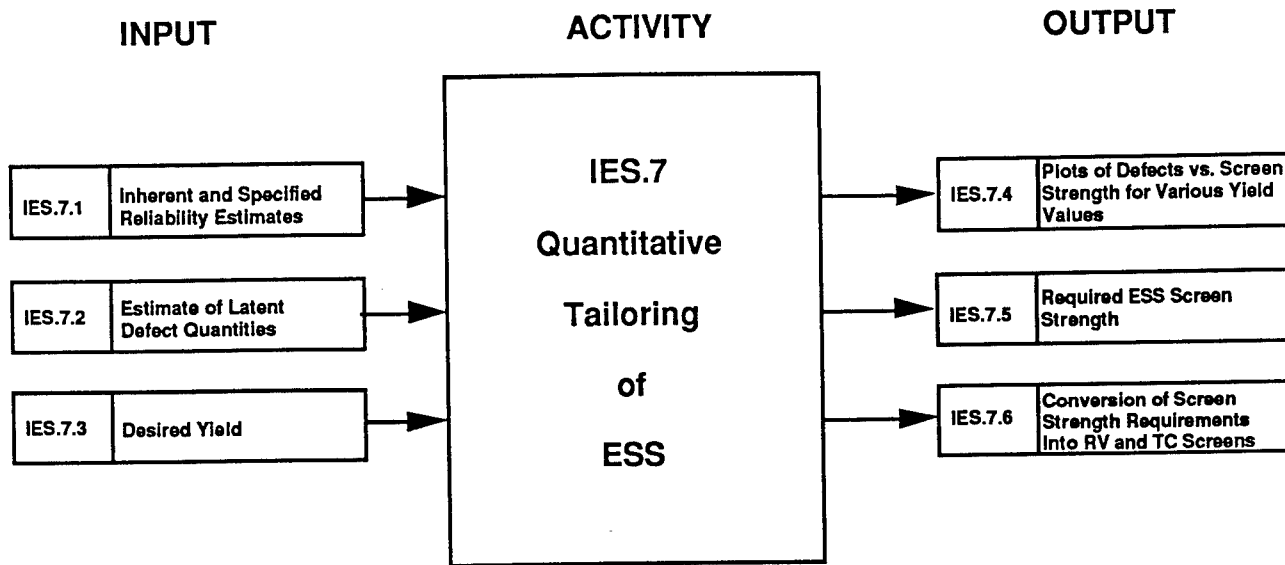

Figure 3.10. Activity IES.7: Quantitative Tailoring of ESS

IES.7 ACTIVITY - Quantitative Tailoring of ESS

The IES guidebook contains an appendix which outlines an approach for determining required screen strengths based on reliability requirements. The methods employ the continuous improvement philosophy where results are measured and screening regimens adjusted accordingly.

IES.7.1 INPUT - Inherent and Specified Reliability Estimates

The inherent reliability is estimated from prediction or other appropriate methods. The specified reliability is that value required by the customer to satisfy objectives.

IES.7.2 INPUT - Estimate of Latent Defect Quantities

An estimate of the quantity of latent defects present is obtained by data from a previous population. If no prior data is available, a method is provided in the IES guidebook to estimate defects present.

IES.7.3 INPUT - Desired Yield

The desired yield and the estimate of defects present are used to tailor screening strength by the methods provided.

IES.7.4 OUTPUT - Plots of Defects vs. Screen Strength for Various Yield Values

Mathematical methods are provided to graphically illustrate a family of first pass yield curves with the ordinate being defects and the abscissa screen strength.

IES.7.5 OUTPUT - Required ESS Screen Strength

The required ESS screen strength is extracted from the plot discussed above in output IES.7.4.

IES.7.6 OUTPUT - Conversion of Screen Strength Required Values Into Appropriate RV and TC Screens

Random Vibration and Temperature Cycling screens are modified based on screen strength

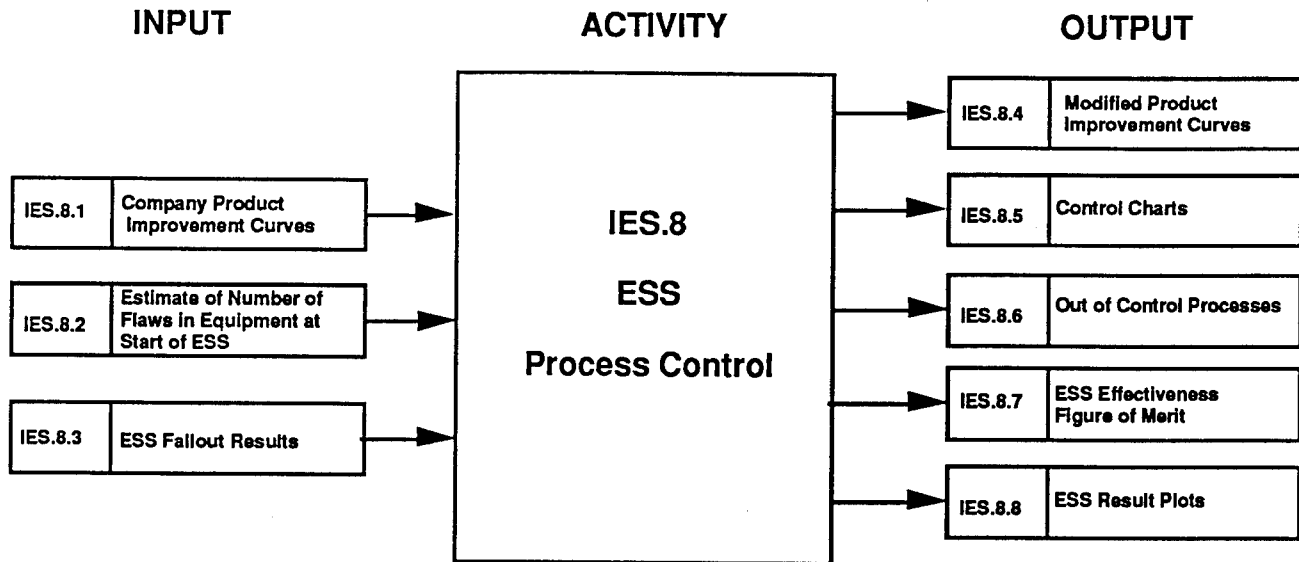

Figure 3.11. Activity IES.8: ESS Process Control

IES.8 ACTIVITY - ESS Process Control

Methodology is provided to help in assuring and controlling both the ESS process of precipitating latent defects to failure and the capability of the production process.

IES.8.1 INPUT - Company Product Improvement Curves

A product improvement curve plots the average number of failure reports per item of final product against product sequential serial numbers.

IES.8.2 INPUT - Estimate of Number of Flaws in Equipment at Start of ESS

The IES guidebook provides a method to estimate the number of flaws based on the slope of the product improvement curve (IES input 8.1), complexity of the hardware, and serial number.

IES.8.3 INPUT - ESS Fallout Results

ESS fallout results are necessary to construct control charts and result plots. An ESS effectiveness figure of merit is also computed from the results.

IES.8.4 OUTPUT - Modified Product Improvement Curves

As data on ESS fallout are accumulated, the product improvement curves should be adjusted accordingly.

IES.8.5 OUTPUT - Control Charts

Control charts plot failures on the y-axis and number of items screened on the x-axis. The IES guidebook provides a method for structuring the control charts, i.e., upper and lower control limits. When a point falls outside of the control limits, the process should be checked for problems.

IES.8.6 OUTPUT - Out of Control Processes

ESS can help to pinpoint manufacturing problems. When an abnormal number of a certain defect type is precipitated during a screen this is an indication that the process may be out of control.

IES.8.7 OUTPUT - ESS Effectiveness Figure of Merit

The IES document provides a gross figure of merit which can be used in some cases. The figure of merit is defined as the ratio between the average total failures per item and the number of flaws per item at the start of ESS. The guidebook recommends the use of control charts as a better method of controlling the screening process.

IES.8.8 OUTPUT - ESS Result Plots

ESS result plots are recommended for use in lieu of control charts when a predetermined value for failures per equipment is not available but a value for failures per cycle is. In this case failures per unit would be plotted against number of thermal cycles. The plots should be used to increase or decrease the number of cycles in the screen.

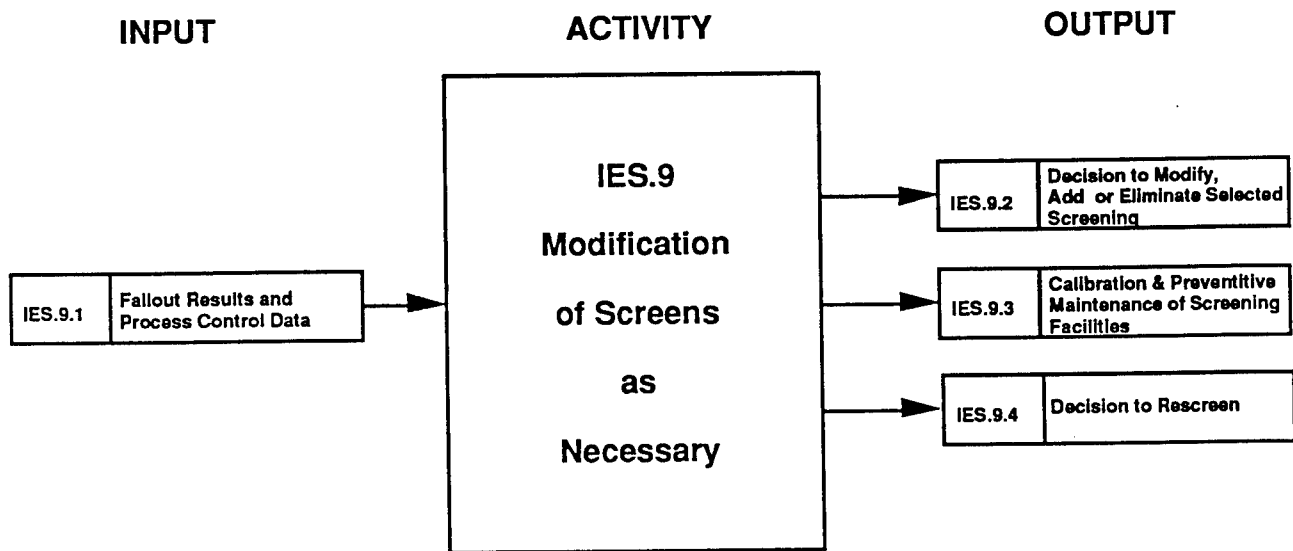

Figure 3.12. Activity IES.9: Modification of Screens as Necessary

IES.9 ACTIVITY - Modification of Screens as Necessary

During the course of a screening program it is often necessary to modify screening regimens based on observed and calculated results.

IES.9.1 INPUT - Fallout Results and Process Control Data

This includes all of the data observed, calculated and tabulated in Activities IES.7 and IES.8.

IES.9.2 OUTPUT - Decision to Modify, Add or Eliminate Selected Screening

Screens are modified as fallout or a lack of fallout are observed. If a new class of defects is discovered ESS should also be modified accordingly.

IES.9.3 OUTPUT - Calibration & Preventive Maintenance of Screening Facilities

Proper maintenance of the ESS equipment is necessary. The IES guidebook recommends periodic calibration and maintenance to assure that the facilities remain accurate and operable.

IES.9.3 OUTPUT - Decision to Rescreen

Guidelines are recommended to rescreen to certain levels/stresses after repairs are made.

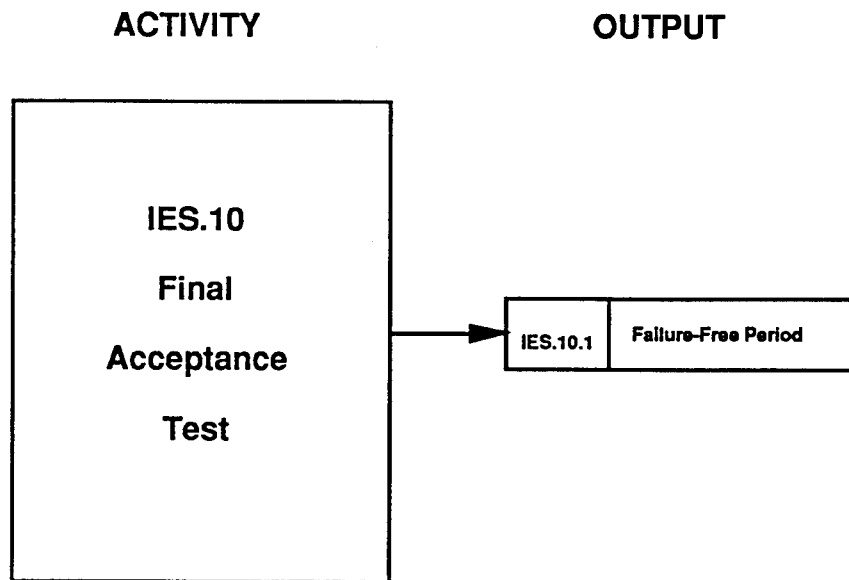

Figure 3.13. Activity IES.10: Final Acceptance Test

IES.10 ACTIVITY - Final Acceptance Test

The final acceptance is conducted after all ESS and post ESS functional test.

IES.10.1 OUTPUT - Failure-Free Period

The IES guidebook recommends the determination of a failure-free requirement for the final acceptance test.

3.2 Tri-Service Environmental Stress Screening Guidelines (Dated July 1993)

3.2.1 Discussion of Tri-Service Environmental Stress Screening Guidelines

The Tri-Service ESS Guidelines document was developed by a tri-service committee to resolve the problems and confusion associated with having several independent guidebooks. The Institute Of Environmental Sciences (IES), ESS Of Electronic Hardware (ESSEH) Committee also added to the preparation/review. Portions of the IES-ESSEH Environmental Stress Screening Guidelines for Assemblies were reprinted for use in this document. The book contains guidance in the areas of ESS program management, project engineering, and contracting. Two major sections are devoted to methods used for determining appropriate initial random vibration and temperature cycling profiles and placement through experimentation. For random vibration, the recommended method is the vibration survey where extensive guidance is provided for both a general and a simplified technique. The guidebook also describes the use of step-stress tests, fault replication tests, and heritage screens. For temperature cycling, recommended techniques for establishing starting profiles include the thermal survey and heritage screen. The level of assembly addressed in the guidelines document is from the printed wiring assembly up to the system level. Part level ESS guidance is not included.

3.2.2 Tri-Service ESS Guidelines Process

Figure 3.14 illustrates the top level activities flow of the Tri-Service ESS Guidelines document. Figures 3.15 through 3.25 illustrate the individual activities of the process along with their inputs and outputs. Activity and input and output descriptions follow each illustration.

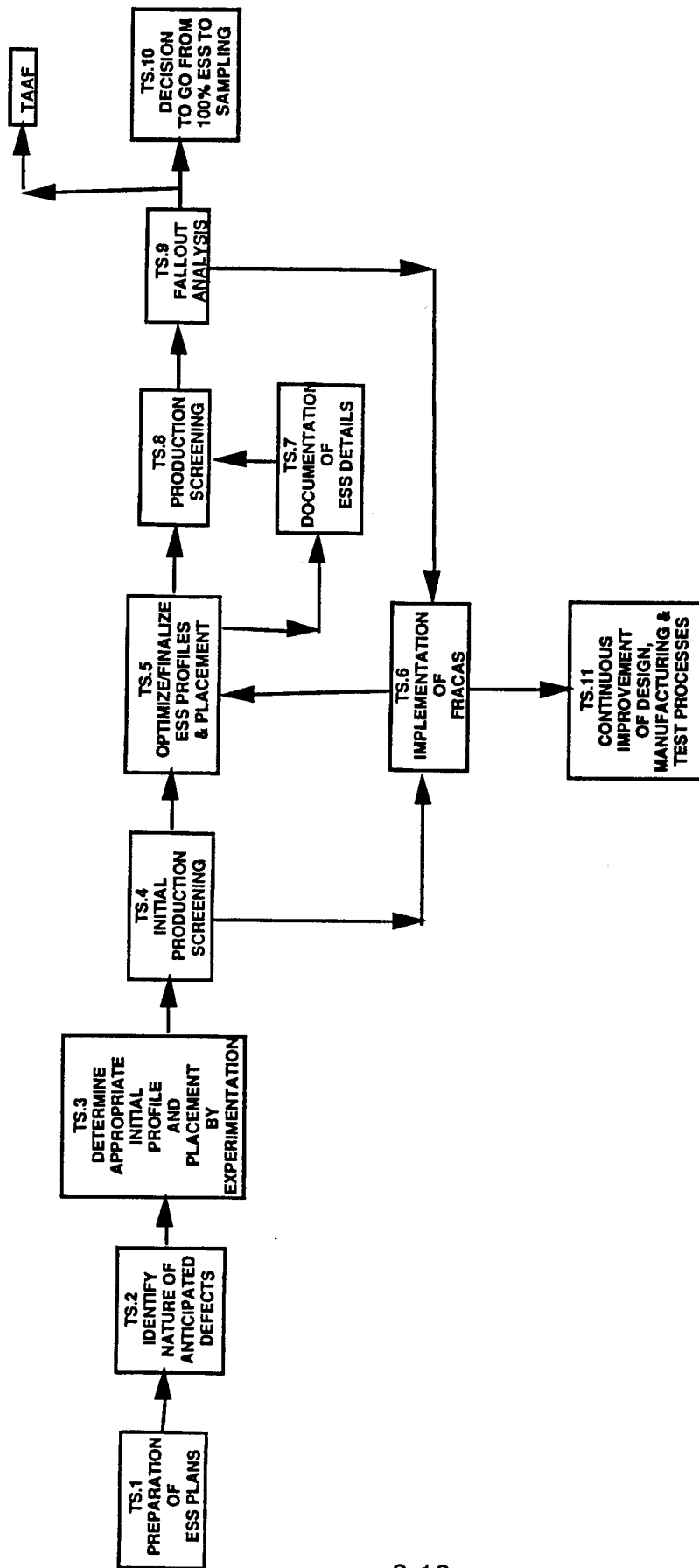

Figure 3.14. Tri-Service ESS Guidelines Top Level Activities Flow Diagram

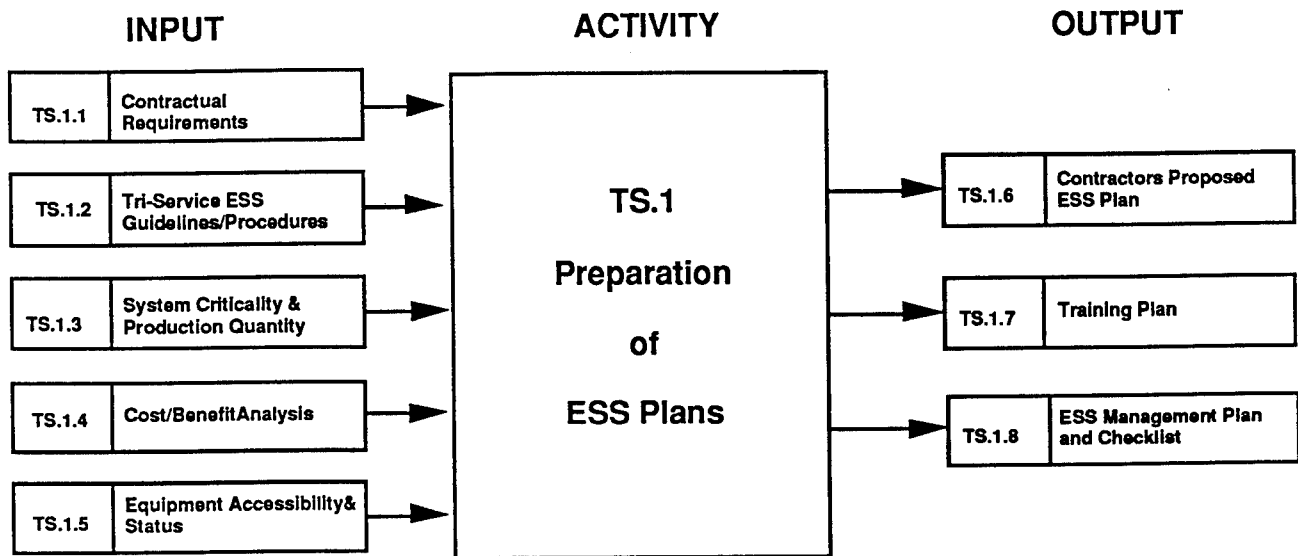

Figure 3.15. Activity TS.1: Preparation of ESS Plans

TS.1 ACTIVITY - Preparation of ESS Plans

The ESS Tri-Service Guidelines document provides planning guidance useful to both the government and the contractor. A program managers checklist is provided as well as considerations for cost, contractual requirements, and other general management guidance.

TS.1.1 INPUT - Contractual Requirements

Contractual requirements are needed as a first step in planning an ESS program. ESS plans must focus on ways to satisfy the requirements.

TS.1.2 INPUT - Tri-Service ESS Guidelines/Procedures

It is necessary to understand the guidebook as early as possible in the program.

TS.1.3 INPUT - System Criticality & Production Quantity

This information is to be used for cost and tradeoff analyses.

TS.1.4 INPUT - Cost/Benefit Analysis

The analysis considers cost tradeoffs associated with the assembly level of ESS, automation vs. manual labor, equipment availability/acquisition, system criticality, production quantity, conditions of ESS relative to power on vs. power off, Input/Output conditions, and monitoring.

TS.1.5 INPUT - Equipment Accessibility & Status

Available equipment vs. equipment requirements should be well thought out during the ESS planning phase.

TS.1.6 OUTPUT - Contractors Proposed ESS Plan

The guidebook recommends that the contractor proposes an ESS plan that overviews all aspects of the ESS program.

TS.1.7 OUTPUT - Training Plan

A training plan is recommended to assess the level of knowledge of all personnel involved in the ESS program and to fill any voids.

TS.1.8 OUTPUT - ESS Management Plan and Checklist

A checklist is provided in the guidebook for use in developing an ESS management plan. This is useful to both the government and contractor.

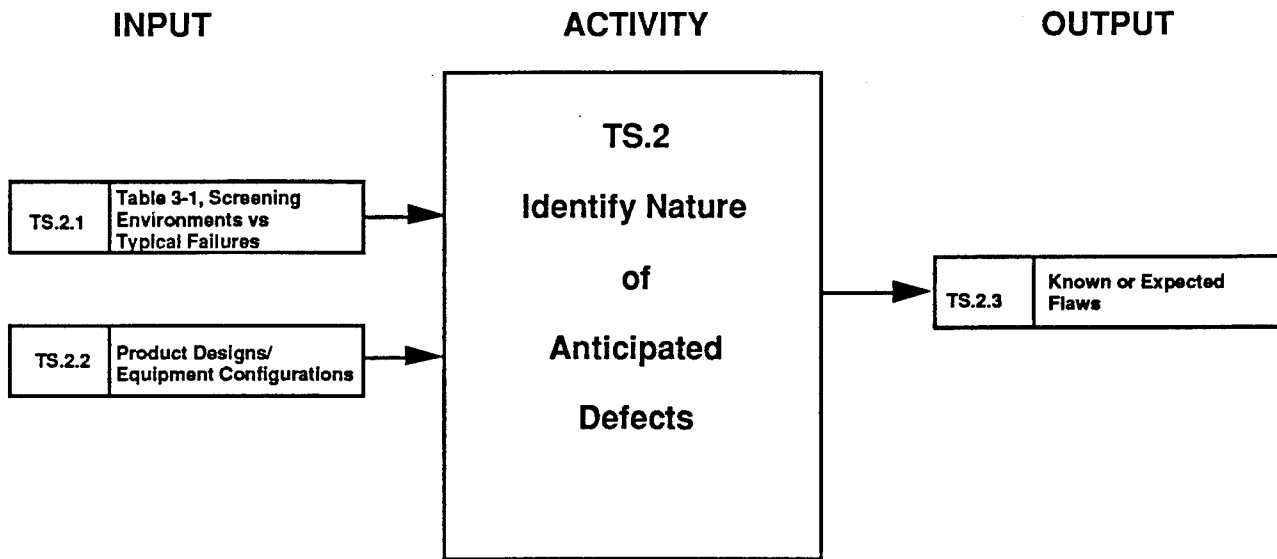

Figure 3.16. Activity TS.2: Identify Nature of Anticipated Defects

TS.2 ACTIVITY - Identify Nature of Anticipated Defects

This activity involves studying the equipment and determining the typical flaws expected to be precipitated through ESS.

TS.2.1 INPUT - Table 3-1, Screening Environments vs. Typical Failures

The table, which is provided in the guidebook gives examples of various types of defects that are generally precipitated through thermal cycling, vibration, or both.

TS.2.2 INPUT - Product Designs/Equipment Configurations

The equipment makeup is necessary for determining the nature of anticipated defects that will be precipitated.

TS.2.3 OUTPUT - Known or Expected Flaws

This information is necessary in order to help select the appropriate ESS environments. ESS personnel should be aware of which defect types are likely to be screened out.

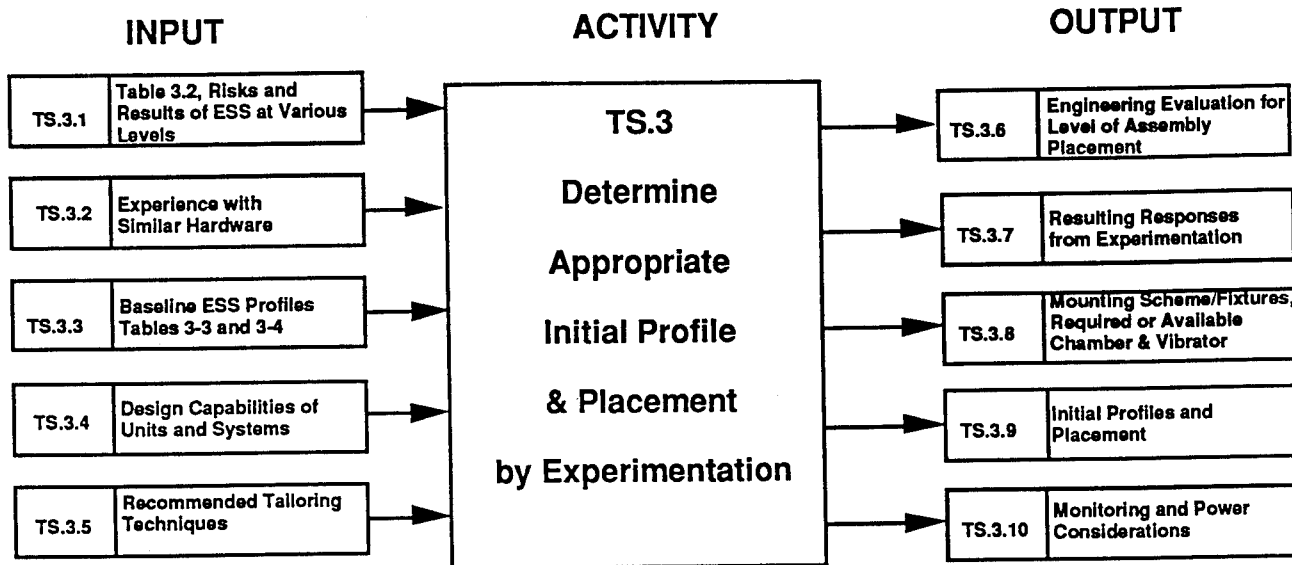

Figure 3.17. Activity TS.3 Determine Appropriate Initial Profile & Placement by Experimentation

TS.3 ACTIVITY - Determine Appropriate Initial Profile & Placement by Experimentation

This activity involves the determination of optimum RV and TC starting profiles and placement through procedures recommended in sections 4 and 5 of the guidebook.

TS.3.1 INPUT - Table 3.2, Risks and Results of ESS at Various Levels

The table provides relative levels of risk and categorizes cost and expected results based on the level of assembly that ESS is applied. Whether or not power is applied, whether the equipment is fully functional or not, and whether or not the equipment is monitored are all taken into consideration.

TS.3.2 INPUT - Experience with Similar Hardware

Data available from past field or ESS experience is useful in setting initial profiles.

TS.3.3 INPUT - Baseline ESS Profiles, Tables 3-3 and 3-4

Baseline vibration and temperature cycling profiles are recommended in the guidebook. These are minimum levels to assure screening effectiveness.

TS.3.4 INPUT - Design Capabilities of Units and Systems

Profiles must not exceed the design capabilities of the units and systems to be exposed to screening.

TS.3.5 INPUT - Recommended Tailoring Techniques

Sections 4 and 5 of the guidebook contain recommended tailoring techniques for vibration and thermal screens. For vibration these include vibration survey, step-stress tests, fault replication tests, and heritage screen. For thermal screens these include thermal survey and heritage screen.

TS.3.6 OUTPUT - Engineering Evaluation for Level of Assembly Placement

Based on the inputs to activity TS.3, an engineering evaluation will result on the appropriate level of assembly determined to be suitable for the screens.

TS.3.7 OUTPUT - Resulting Responses from Experimentation

Responses from the experiments are used to further refine initial screening profiles.

TS.3.8 OUTPUT - Mounting Schemes/Fixtures, Required or Available Chamber and Vibrator

This information should be available at the start of or soon after experimentation. The information includes those schemes, fixtures, chambers and vibrators that will be required for initial production screening.

TS.3.9 OUTPUT - Initial Profiles and Placement

The initial profiles and placement resulting from activity 3 are those for initial production screening.

TS.3.10 OUTPUT - Monitoring and Power Considerations

What points will be monitored during the screen and whether or not equipment will be fully functional/powered with normal inputs and outputs should be decided at this time.

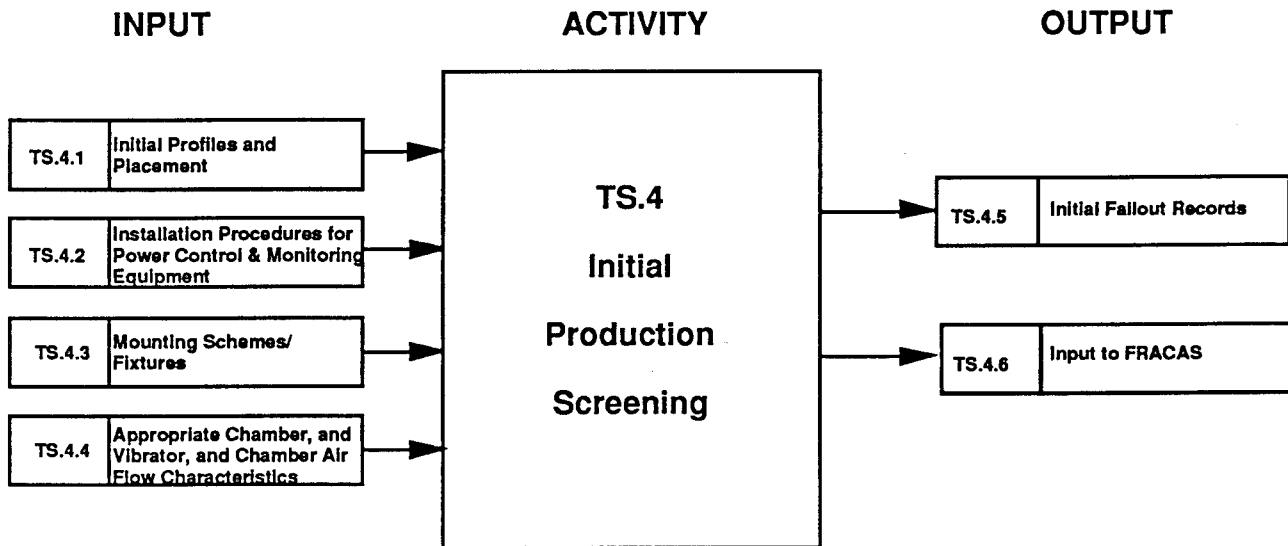

Figure 3.18. Activity TS.4: Initial Production Screening

TS.4 ACTIVITY - Initial Production Screening

The initial production screening is the first screening conducted on the production lot. Lessons are learned from the initial screening to help optimize/refine screening profiles and placement.

TS.4.1 INPUT - Initial Profiles and Placement

The same as output TS.3.9.

TS.4.2 INPUT - Installation Procedures for Power Control & Monitoring Equipment

This information is derived from output TS.3.10 and from existing/known ESS procedures.

TS.4.3 INPUT - Mounting Schemes/Fixtures

The same as output TS.3.8.

TS.4.4 INPUT - Appropriate Chamber, and Vibrator and Chamber Air Flow Characteristics

This information is derived from outputs TS.3.7 and TS.3.8.

TS.4.5 OUTPUT - Initial Fallout Records

Records/data are kept on all defect precipitation experienced.

TS.4.6 OUTPUT - Input To FRACAS

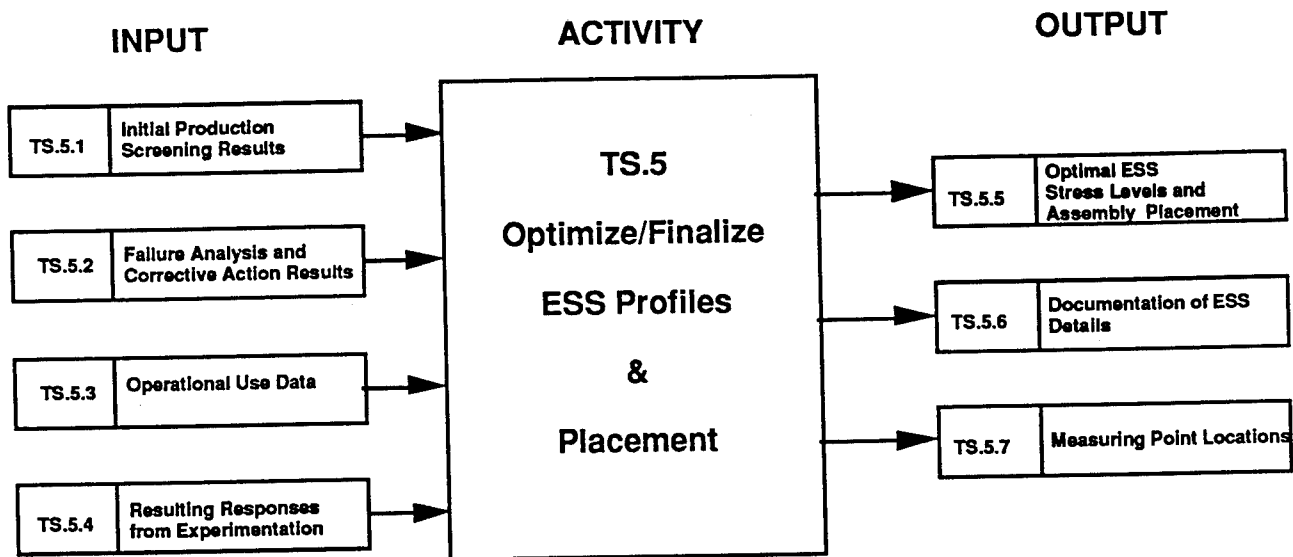

Figure 3.19. Activity TS.5 Optimize/Finalize ESS Profiles & Placement

TS.5 ACTIVITY - Optimize/Finalize ESS Profiles & Placement

As soon as initial production screening takes place, results should be available to modify ESS profiles and placement for final production ESS.

TS.5.1 INPUT - Initial Production Screening Results

This includes the initial fallout records (Output TS.4.5) and any other lessons learned/observation from Activity 4, Initial Production Screening.

TS.5.2 INPUT - Failure Analysis and Corrective Action Results

Determinations can be made as to whether or not precipitated defects were due to overstress. FRACAS data is a good source for this data.

TS.5.3 INPUT - Operational Use Data

Failure analysis results should not only include those from initial production screening but also any available field results.

TS.5.4 INPUT - Resulting Responses From Experimentation

This is the same as output TS.3.7.

TS.5.5 OUTPUT - Optimal ESS Stress Levels And Assembly Placement

Upon study of the inputs to this activity, optimal stress levels that will precipitate defects but not overstress the equipment should be generated. Appropriate level of placement is also refined at this time.

TS.5.6 OUTPUT - Documentation of ESS Details

Appropriate details are documented to maintain a current technical data package.

TS.5.7 OUTPUT - Measuring Point Locations

Final measuring point locations for production screening are determined/finalized at this time.

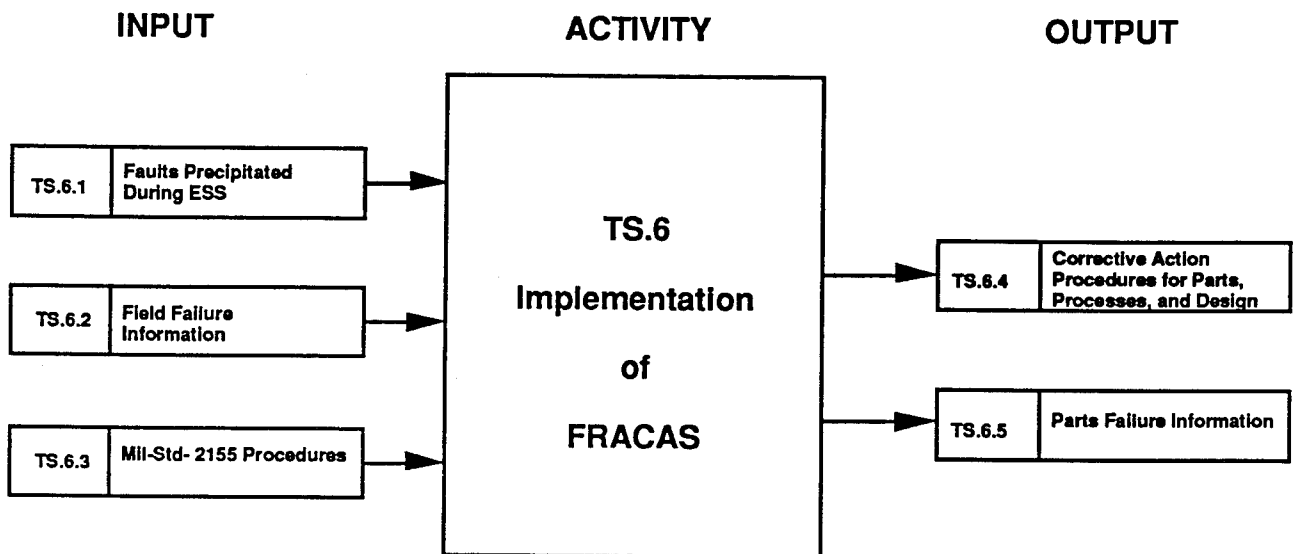

Figure 3.20. Activity TS.6: Implementation of FRACAS

TS.6 Activity - Implementation of FRACAS

A FRACAS - Failure Reporting, Analysis And Corrective Action System should be in place at the contractor facility. Its interaction with the ESS program as discussed in the Tri-Service guidebook is outlined here.

TS.6.1 INPUT - Faults Precipitated During ESS

All faults precipitated during screening should be reported and analyzed by the contractors closed loop FRACAS.

TS.6.2 INPUT - Field Failure Information

Procedures should be in place to track and record field failure information.

TS.6.3 INPUT - Mil-Std-2155 Procedures

Mil-Std-2155, "Failure Reporting, Analysis And Corrective Action System" establishes requirements and criteria for a FRACAS.

TS.6.4 OUTPUT - Corrective Action Procedures for Parts, Processes, and Design

Corrective action procedures are necessary to correct any parts, design, or manufacturing problems uncovered during the screening process.

TS.6.5 OUTPUT - Parts Failure Information

The guidebook recommends supplying parts failure information to manufacturers for the purpose of continuous improvement.

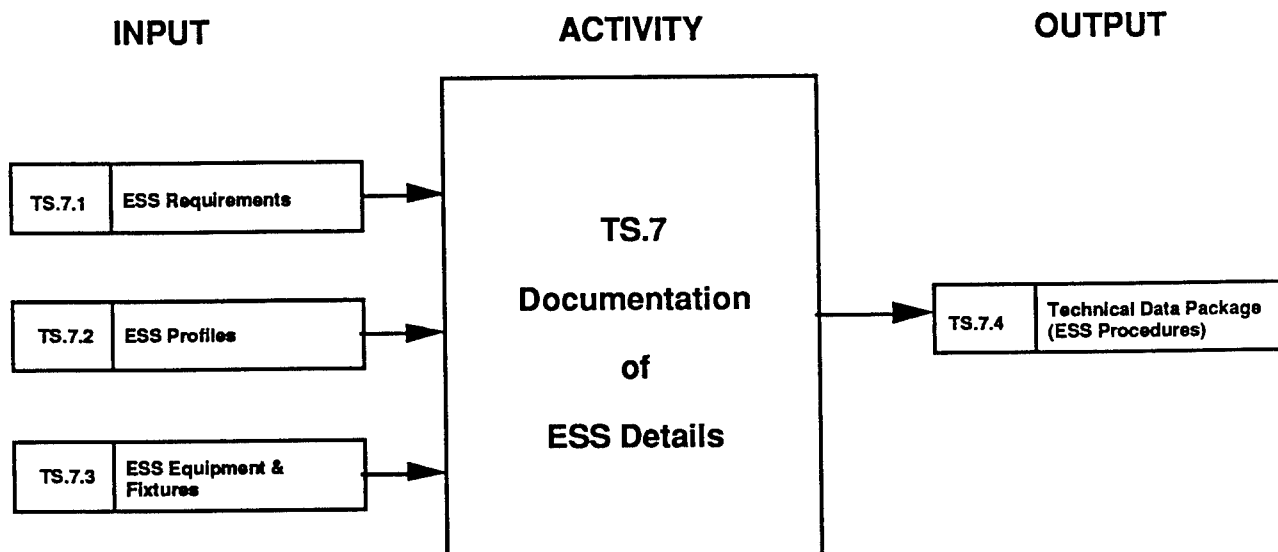

Figure 3.21. Activity: TS.7 Documentation of ESS Details

TS.7 ACTIVITY - Documentation of ESS Details

The guidebook recommends documentation of ESS details as part of the technical data package.

TS.7.1 INPUT - ESS Requirements

These are contractual requirements discussed in input TS.1.1.

TS.7.2 INPUT - ESS Profiles

These are final production ESS profiles determined as part of activity TS.5.

TS.7.3 INPUT - ESS Equipment & Fixtures

This includes the mounting schemes, fixtures, chambers, and vibrators required for production screening.

TS.7.4 OUTPUT - Technical Data Package (ESS Procedures)

This includes all documented ESS details. The details should be referenced on the equipment drawings or parts list.

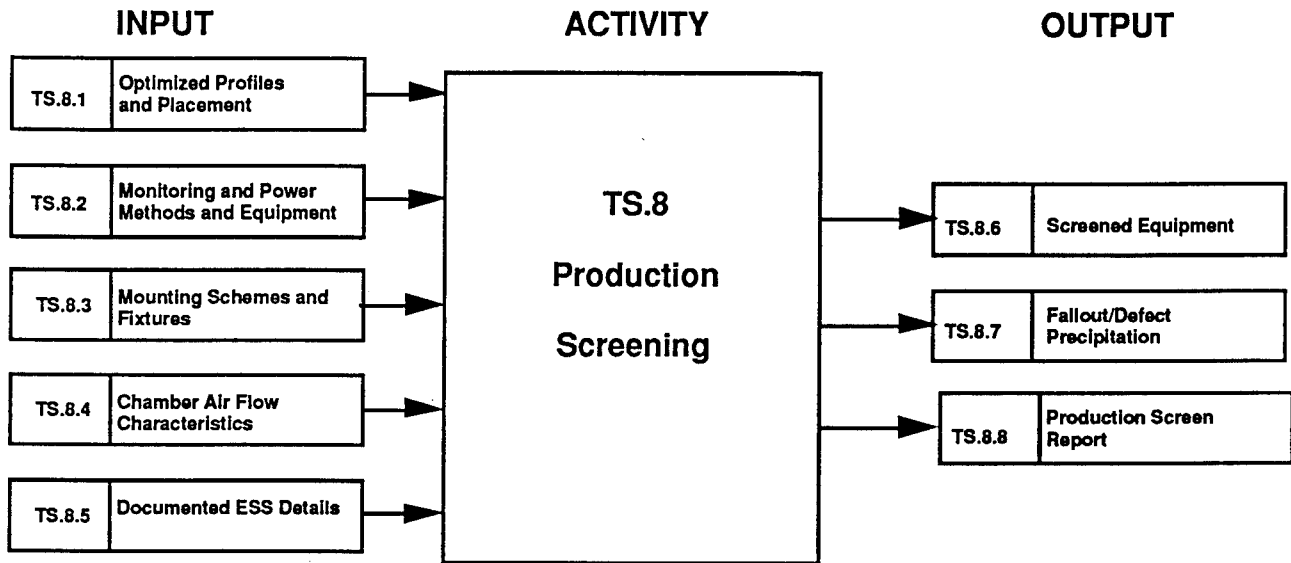

Figure 3.22. Activity TS.8 Production Screening

TS.8 ACTIVITY - Production Screening

This activity involves the actual ESS of the production assemblies.

TS.8.1 INPUT - Optimized Profiles and Placement

This includes information obtained from output TS.5.4.

TS.8.2 INPUT - Monitoring and Power Methods and Equipment

This includes the information obtained from output TS.3.10 and any necessary equipment.

TS.8.3 INPUT - Mounting Schemes and Fixtures

This is the same as output TS.3.8 with necessary modifications based on lessons learned from initial production screening.

TS.8.4 INPUT - Chamber Air Flow Characteristics

This is the same as input TS.4.4.

TS.8.5 INPUT - Documented ESS Details

This is derived from output TS.5.5 and Output TS.7.4.

TS.8.6 OUTPUT - Screened Equipment

This includes all equipment that undergoes screening.

TS.8.7 OUTPUT - Fallout/Defect Precipitation

This includes documentation/investigation of all precipitated defects for input to the causal analysis portion of the FRACAS.

TS.8.8 OUTPUT - Production Screen Report

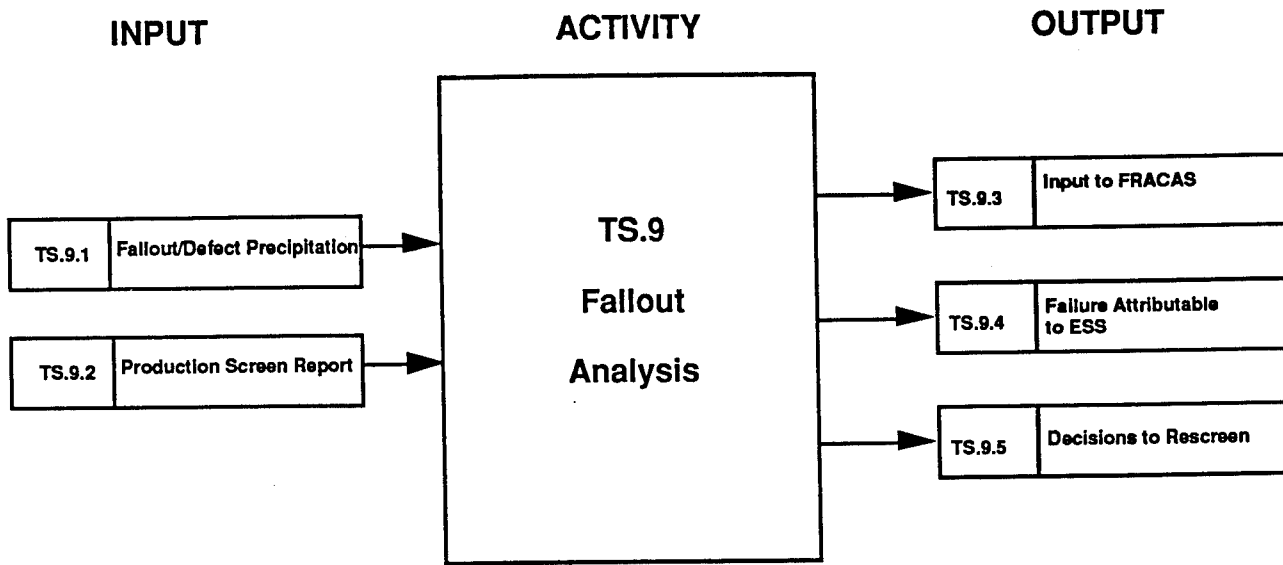

Figure 3.23. Activity: TS.9 Fallout Analysis

TS.9 ACTIVITY - Fallout Analysis

This activity involves the study of defects precipitated during ESS.

TS.9.1 INPUT - Fallout/Defect Precipitation

This is almost the same as output TS.8.7. Here the information is used to make decisions on future screening requirements.

TS.9.2 INPUT - Production Screen Report

This is the same as output TS.8.9.

TS.9.3 OUTPUT - Input to FRACAS

Fallout data should be made available to the dynamic FRACAS.

TS.9.4 OUTPUT - Failures Attributable to ESS

A listing/tabulation of all failures precipitated during ESS.

TS.9.5 OUTPUT - Decision to Rescreen

The guidebook contains helpful information on how to go about rescreening in a manner which is not counter-productive to useful life.

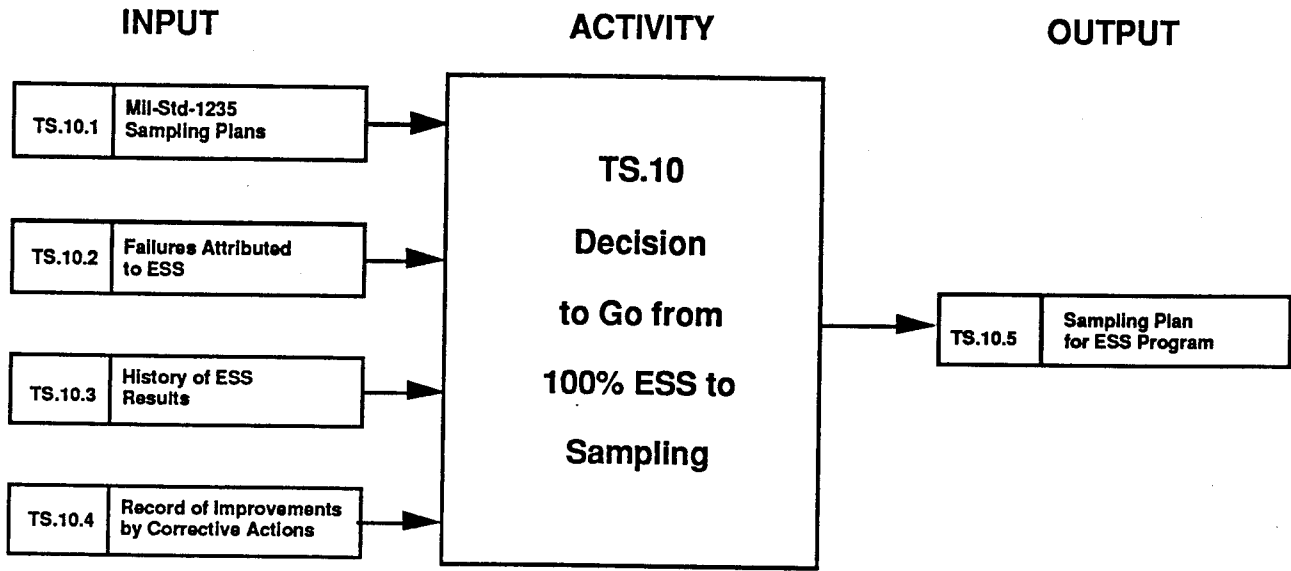

Figure 3.24. Activity TS.10: Decision to Go from 100% ESS to Sampling

TS.10 ACTIVITY - Decision to Go from 100% ESS to Sampling

At the phase when manufacturing processes and parts are under control and ESS is no longer precipitating a significant number of defects, a decision must be made to go from 100% ESS to sampling. If process control is lost at any time, the guidebook recommends reverting to 100% ESS.

TS.10.1 INPUT - MII-Std-1235 Sampling Plans

This standard is titled "Single-and Multi-Level Continuous Sampling Procedures and Tables for Inspection by Attributes". It provides methods for applying continuous sampling plans for inspection.

TS.10.2 INPUT - Failures Attributed to ESS

This is the same as output TS.9.4.

TS.10.3 INPUT - History of ESS Results

TS.10.4 INPUT - Record of Improvements by Corrective Actions

A determination should be made to see if any decline in ESS failures is due to corrective actions as opposed to other manufacturing changes that render the ESS ineffective.

TS.10.5 OUTPUT - Sampling Plan for ESS Program

A sampling plan is recommended when 100% ESS is no longer conducted. The sampling plan provides means to monitor the program to make sure that improvements are still effective.

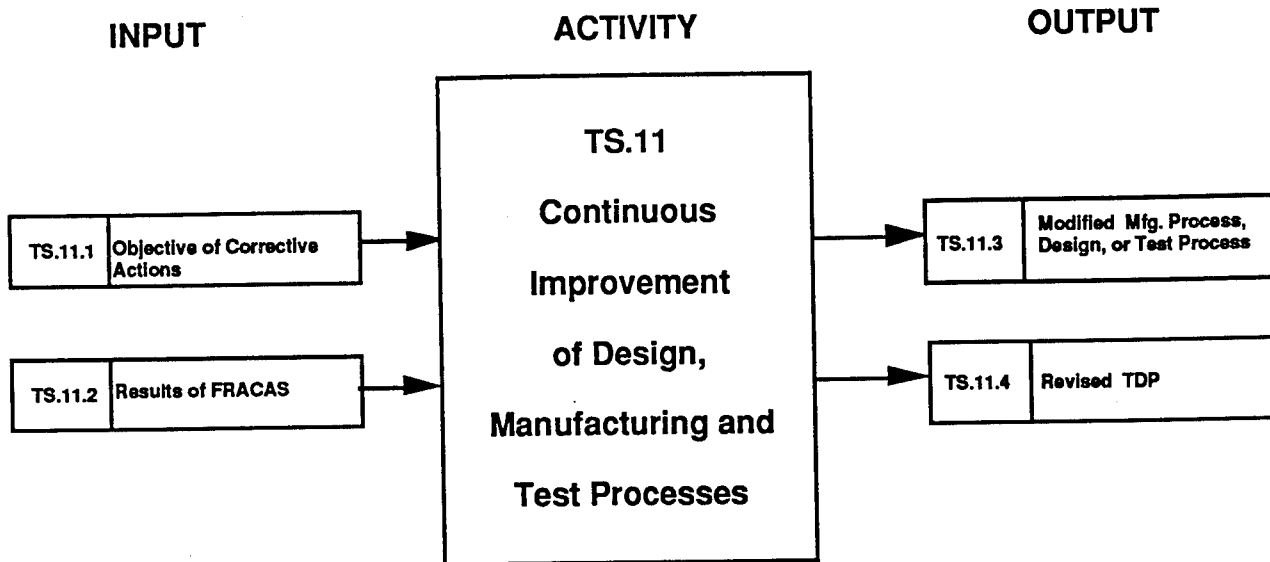

Figure 3.25. Activity TS.11 Continuous Improvement of Design, Manufacturing and Test Processes

TS.11 ACTIVITY - Continuous Improvement of Design, Manufacturing and Test Processes

The guidebook stresses the fact that environmental stress screening can help to optimize the manufacturing process resulting in cost savings. This activity illustrates how ESS interacts with the continuous improvement process.

TS.11.1 INPUT - Objective of Corrective Action

Specific objectives of corrective action should be spelled out.

TS.11.2 INPUT - Results of FRACAS

This includes information pertaining to any improvements in the design, manufacturing, and test processes resulting from the closed loop FRACAS.

TS.11.3 OUTPUT - Modified Manufacturing, Design, or Test Processes

TS.11.4 OUTPUT - Revised Technical Data Package

3.3 Navy Manufacturing Screening Program, NAVMAT P-9492 (Dated May 1979)

3.3.1 Discussion of Navy Manufacturing Screening Program

The Navy Manufacturing Screening Program document is the original environmental stress screening guidebook. The book was developed as a result of lessons learned from the 1960's manned space program with respect to environmental testing. The guidebook contains engineering guidance on the use of temperature cycling and random vibration as effective ESS means. No administrative guidance is provided. The original intent was not to develop a standard for mandating contractors, however the guidebook has been called out many times in contracts. The random vibration spectrum characterized in the book has become the standard for just about every ESS document ever written, i.e. 6g_{RMS} consisting of .04g²/Hz with a frequency range of 20 - 2000 Hz and 3 dB/octave rolloffs from 80 to 20 Hz and 350 to 2000 Hz. The book contains background information on temperature cycling and random vibration, a section on recommended screening profiles, and a detailed appendix outlining a 1970's technology procedure for generating and applying random vibration utilizing a cassette tape deck. A companion document NAVMAT P-4855-1A/NAVSO P-3641, "Navy Power Supply Reliability" was written to be used with NAVMAT P-9492 when screening power supplies. The level of assembly addressed in NAVMAT P-9492 is from the printed wiring assembly up to the "black box" LRU level. Part level ESS guidance is not included.

3.3.2 Navy Manufacturing Screening Program Process

Figure 3.26 illustrates the top level activities flow of the Navy Manufacturing Screening Program (NAVMAT P-9492) document. Figures 3.27 and 3.28 illustrate the individual activities of the process along with their inputs and outputs. Activity and input and output descriptions follow each illustration.

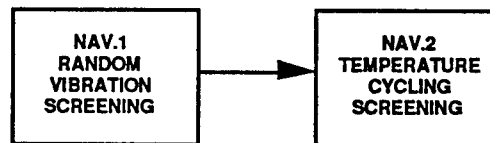

Figure 3.26. Navy Manufacturing Screening Program
Top Level Activities Flow Diagram

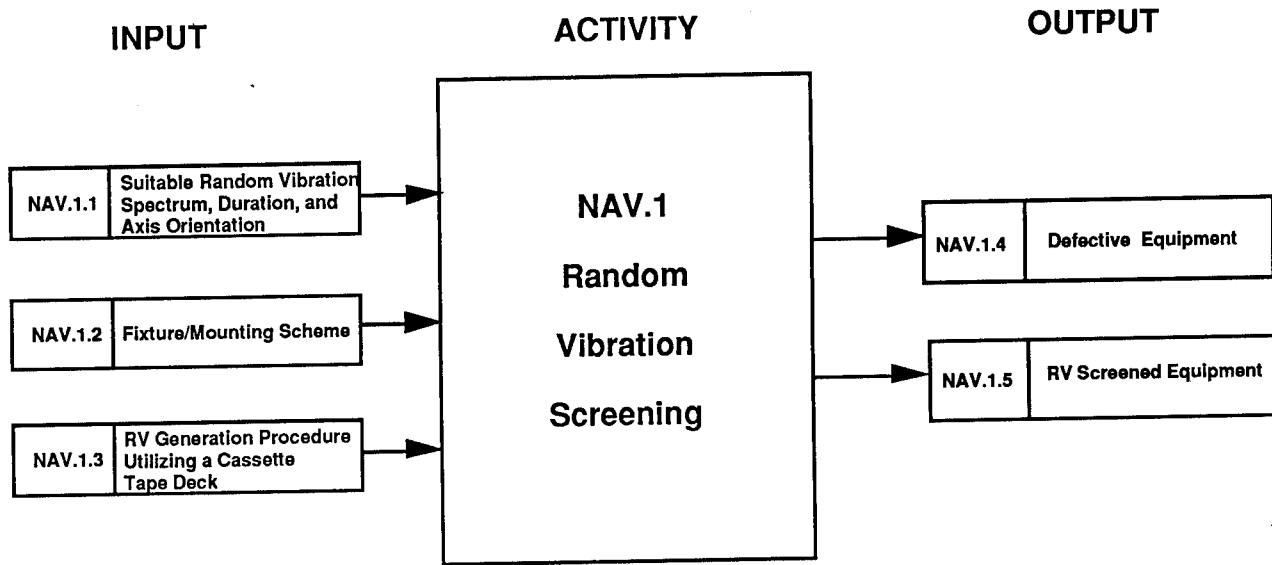

Figure 3.27. Activity NAV.1: Random Vibration Screening

NAV.1 ACTIVITY - Random Vibration Screening

This activity is one of the only two that make up the relatively straight forward process of the NAVMAT ESS guidebook. Random vibration screening involves subjecting the equipment to a predetermined level and duration of random vibration.

NAV.1.1 INPUT - Suitable Random Vibration Spectrum, Duration, and Axis Orientation

The random vibration spectrum recommended by the NAVMAT document is 6 gRMS consisting of .04g²/Hz with a frequency range of 20 - 2000 Hz and 3 dB/octave rolloffs from 80 to 20 Hz and 350 to 2000 Hz. Recommended duration is for at least 10 minutes if a single axis is sufficient. If more than one axis is required then it is advised to use at least 5 minutes in each axis.

NAV.1.2 INPUT - Fixture/Mounting Scheme

Equipment under test should be hard mounted to a shaker table. The fixture/mounting scheme should be consistent across all units being screened.

NAV.1.3 INPUT - Random Vibration Generation Procedure Utilizing a Cassette Tape Deck

This technique is 1970's technology and is most likely not employed anymore given advances in state-of-the-art vibration equipment. When the technique was originally developed, it represented a cost savings for the then expensive random vibration screen generation.

NAV.1.4 Defective Equipment

All equipment failing as a result of the screen.

NAV.1.5 Random Vibration Screened Equipment

All equipment/assemblies having survived the RV screen. The NAVMAT document specifies that RV and TC screens could occur simultaneously or consecutively. The book, however, doesn't recommend a sequential order. General practice now calls for random vibration followed by temperature cycling.

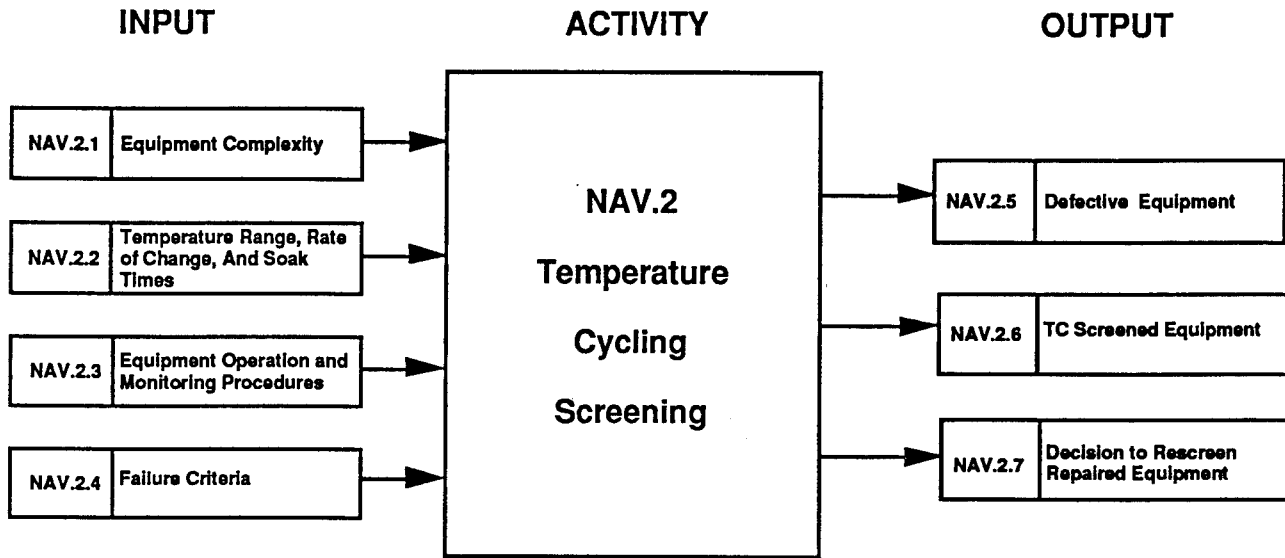

Figure 2.28. Activity NAV.2: Temperature Cycling Screening

NAV.2 ACTIVITY - Temperature Cycling Screening

This is the second of the two activities comprising the NAVMAT ESS process. This activity involves subjecting the equipment to a recommended temperature cycling regimen.

NAV.2.1 INPUT - Equipment Complexity

The NAVMAT document recommends tailoring the number of temperature cycles to the equipment complexity which is determined by the number of parts comprising the system.

NAV.2.2 INPUT - Temperature Range, Rate of Change, and Soak Times

The NAVMAT document recommends optimum ranges for these parameters.

NAV.2.3 INPUT - Equipment Operation and Monitoring Procedures

The document recommends operation during temperature cycling with turn-off during chamber cool down. Monitoring is dictated by cost.

NAV.2.4 INPUT - Failure Criteria

Recommendations for a failure free final cycle are stated.

NAV.2.5 OUTPUT - Defective Equipment

This represents fallout from the TC screens.

NAV.2.6 OUTPUT - TC Screened Equipment

All equipment/assemblies having survived the TC screen.

NAV.2.7 OUTPUT - Decision to Rescreen Repaired Equipment

After each repair, the NAVMAT document recommends review for maintenance induced defects. When complexity of repair dictates or undesirable/questionable circumstances of any kind occur, rescreening is recommended.

3.4 Mil-Hdbk-344A, Environmental Stress Screening of Electronic Equipment (Dated August 1993)

3.4.1 Discussion of Mil-Hdbk-344A

Mil-Hdbk-344 was developed as a result of several Rome Laboratory research studies aimed at developing (and improving on) a quantitative approach to environmental stress screening. Rome is the official preparing activity with the responsibility for updating and maintaining the document. The handbook provides techniques for planning and evaluating ESS programs. The guidance contained in the handbook departs from other approaches to ESS in that quantitative methods are extensively used to plan and control both the cost and effectiveness of ESS programs. The quantitative methods contained in the handbook extend the traditional ESS objective by focusing on the defects which remain in the product at delivery and their impact on field reliability. The goal of ESS thus becomes to reduce the latent defect population, at delivery, to a level which is consistent with the reliability requirements for the product. General guidelines and supporting rationale are provided to plan, monitor and control the screening process so that the quantitative goals can be achieved cost effectively.

3.4.2 Mil-Hdbk-344A Process

Figure 344.1 illustrates the top level activities flow of Mil-Hdbk-344A. Figures 3.30 through 3.41 illustrate the individual activities of the process along with their inputs and outputs. Activity and input and output descriptions follow each illustration.

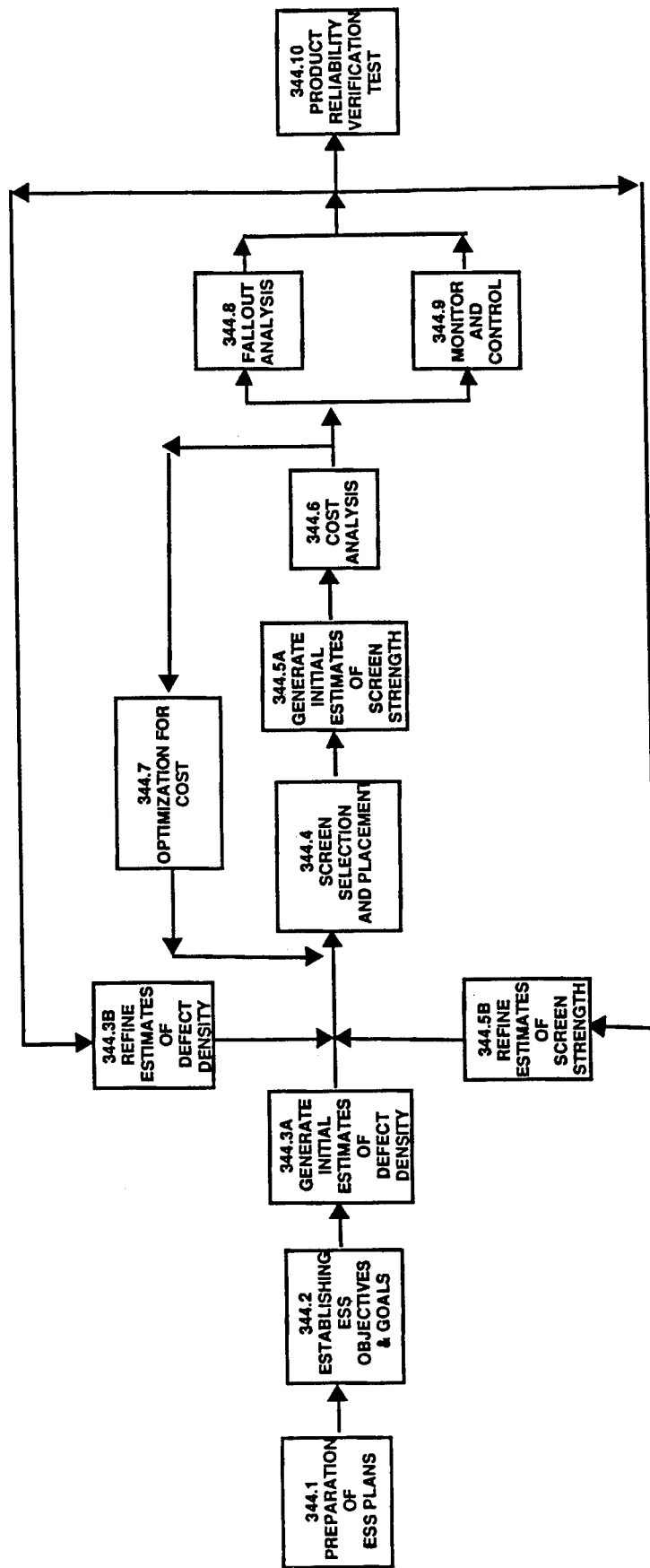

Figure 3.29. Mil-Hdbk-344 Top Level Activities Flow Diagram

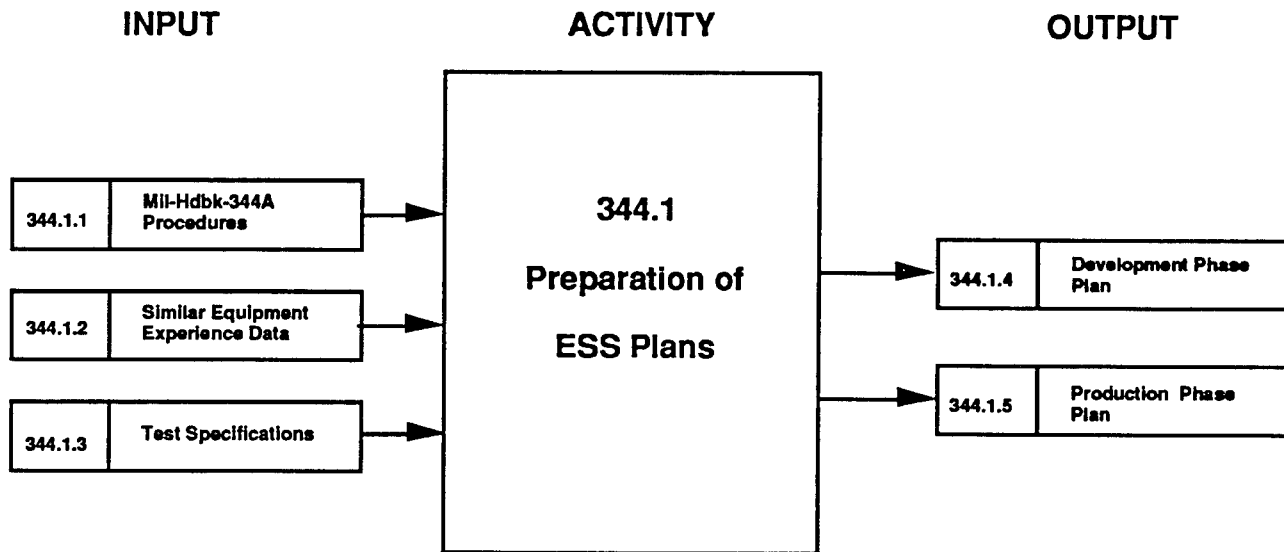

Figure 3.30. Activity 344.1: Preparation of ESS Plans

344.1 ACTIVITY - Preparation of ESS Plans

Mil-Hdbk-344 recommends that the contractor submit development phase and production phase ESS plans to the procuring activity for approval prior to production. Section 4.4 of the handbook provides guidelines on the preparation of such planning documents.

344.1.1 INPUT - Mil-Hdbk-344 Procedures

It is necessary to understand the handbook procedures as soon as possible in the development program.

344.1.2 INPUT - Similar Equipment Experience Data

Such data can be very helpful for planning. The data can be obtained from pre-production ESS experimentation or from actual system experience. Potential sources of data are identified in section 4.4 of Mil-Hdbk-344A and basically are estimates of type and quantity of defects likely to be present in the hardware.

344.1.3 INPUT - Test Specifications

Mil-Hdbk-344A suggests the evaluation of test specifications to ensure that all failure modes arising from various defect types and sources, can be detected by the tests performed either during or following the screens.

344.1.4 OUTPUT - Development Phase Plan

This plan should include reliability requirements, quantitative ESS goals, equipment identification including production quantities, descriptions of initial screens and screening experiments (if applicable), description of the planned data collection and analysis program, description of subcontractor and supplier ESS to be performed, results of preliminary handbook procedure use, and descriptions of the organizational elements that will be responsible for ESS planning and experimentation.

344.1.5 OUTPUT - Production Phase Plan

This plan should include quantitative ESS objectives, breakdown of the assembly level of the equipment which will be screened, descriptions of screens to be applied, including screen parameters and exposure time, descriptions of any results from applying Mil-Hdbk-344A procedures, description of the FRACAS and analysis procedures for control of the screening process, description of the planned production reliability verification test (PRVT) and identification of the organizational elements responsible for conducting and evaluating the effectiveness of the production ESS program.

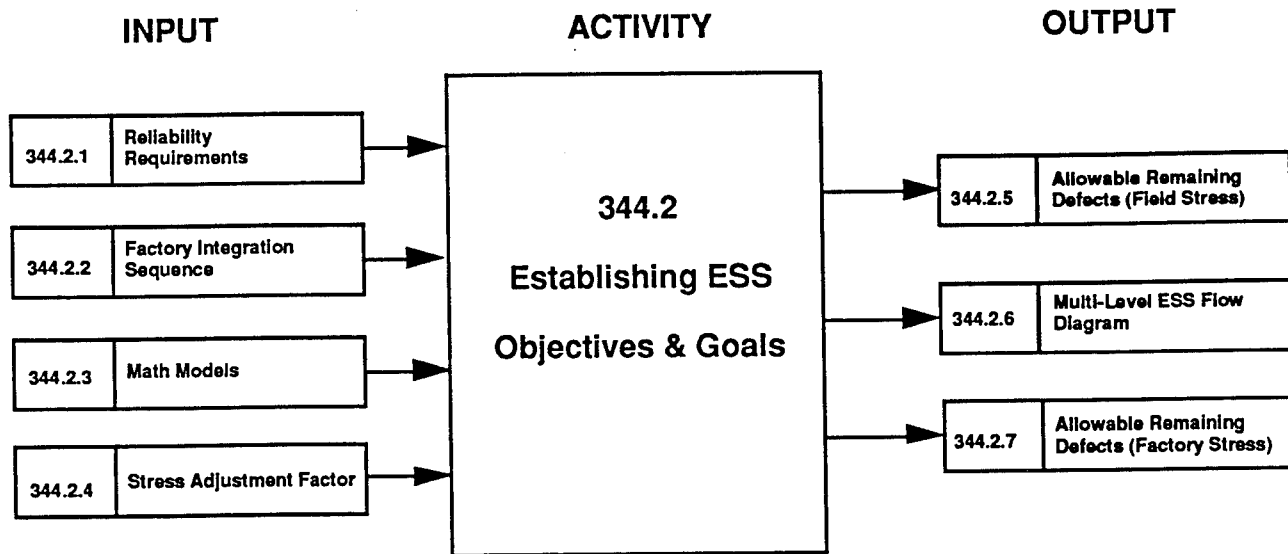

Figure 3.31. Activity 344.2: Establishing ESS Objectives & Goals

344.2 ACTIVITY - Establishing ESS Objectives & Goals

The handbook provides methods to relate reliability requirements to allowable remaining defect density values. This activity marks the first phase of the quantitative modeling and goal setting.

344.2.1 INPUT - Reliability Requirements

Values of limiting or inherent MTBF and required MTBF must be known in order to determine the maximum number of permissible remaining defects.

344.2.2 INPUT - Factory Integration Sequence

The factory integration sequence must be defined with all restrictions and requirements with respect to assembly, calibration and acceptance testing.

344.2.3 INPUT - Math Models

The models found in the handbook in section 5.2.3 are used to compute the allowable remaining defects based on the reliability requirements.

344.2.4 INPUT - Stress Adjustment Factor (SAF)

The SAF is the ratio of the number of defects at the field stress level to those at baseline(factory) stress level. This value is used to adjust the allowable remaining

defect value at field stress to an equivalent value at factory stress. The SAF becomes available during activity 344.3A and is output 344.3A.7.

344.2.5 OUTPUT - Allowable Remaining Defects (Field Stress)

Based on the math models discussed in INPUT 344.2.3 and the reliability requirements discussed in INPUT 344.2.1, the allowable remaining defects at field stress are estimated.

344.2.6 OUTPUT - Multi-Level ESS Flow Diagram

A flow diagram is to be developed depicting the integration and environmental testing requirements. This diagram illustrates the production flow and provides the framework for ESS selection and placement.

344.2.7 OUTPUT - Allowable Remaining Defects (Factory Stress)

This value is calculated using the math model found in Procedure A1, section 5.2.3 of Mil-Hdbk-344A.

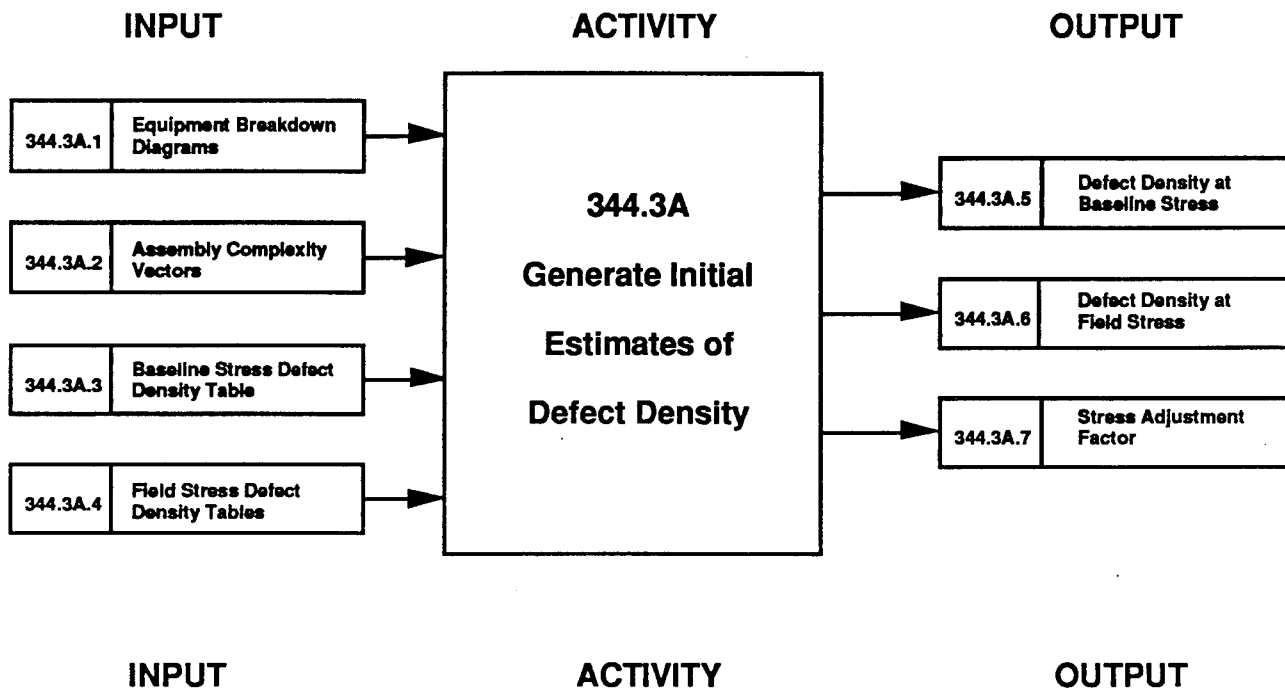

Figure 3.32A. Activity 344.3A: Generate Initial Estimates of Defect Density

344.3 ACTIVITY - Generate Initial Estimates of Defect Density

The intent of this activity is to estimate the initial defects resident in each assembly both from a baseline (factory) and a field stress perspective.

344.3A.1 INPUT - Equipment Breakdown Diagram

A three level equipment breakdown structure is recommended: system, unit, and assembly level.

344.3A.2 INPUT - Assembly Complexity Vector

The assembly complexity vector or matrix comprises the individual complexity vectors for each assembly and subassembly. This basically defines all part types, quantities, connections, leads, terminals, wire connections and PWAs.

344.3A.3 INPUT - Baseline Stress Defect Density Table

The handbook provides this table which contains values of defect density for a factory screening environment for various electronic component types and assembly activities.

344.3A.4 INPUT - Field Stress Defect Density Tables

The handbook provides tables which contain values of defect density for various field environments and quality levels.

344.3A.5 OUTPUT - Defect Density at Baseline Stress

The initial estimated number of defects at baseline stress is determined by multiplying the assembly complexity vector by the baseline stress defect density vector values obtained from INPUT 344.3A.3.

344.3A.6 OUTPUT - Defect Density at Field Stress

The initial estimated number of defects at field stress is determined by multiplying the assembly complexity vector by field stress defect density vector values obtained from INPUT 344.3A.4.

344.3A.7 OUTPUT - Stress Adjustment Factor (SAF)

The SAF is determined as the ratio of the number of defects at the field stress level to the number of defects at the baseline stress level.

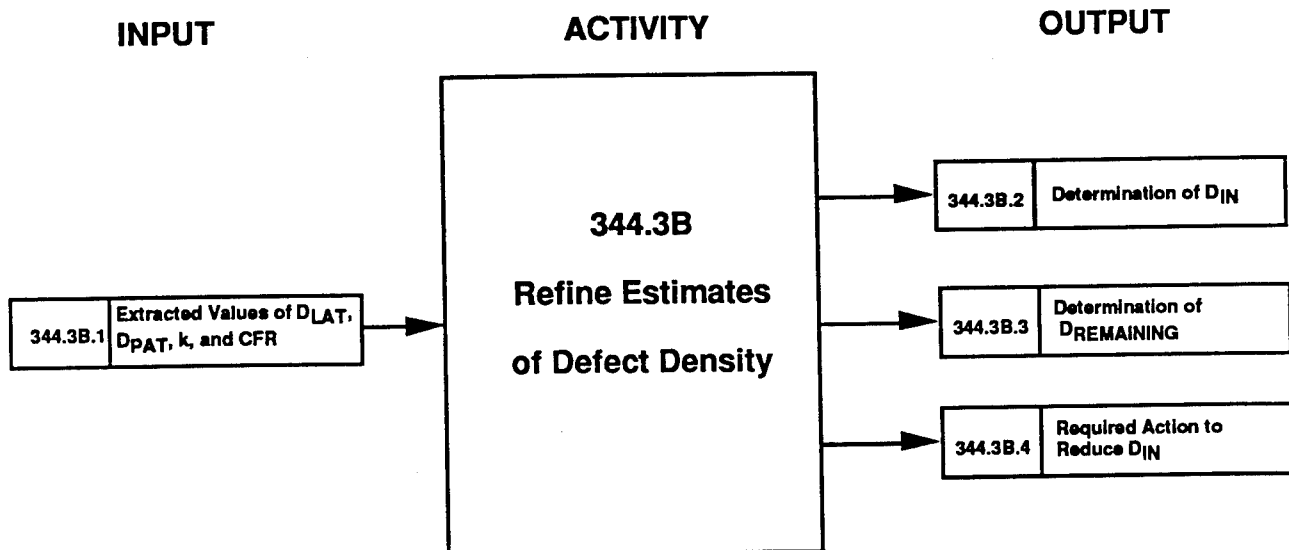

Figure 3.32B. Activity 344.3B: Refine Estimates of Defect Density

344.3B ACTIVITY - Refine Estimates Of Defect Density

This activity involves the computation of incoming defect density (D_{IN}) and remaining defect density ($D_{REMAINING}$) from analysis of fallout data. The values are used to indicate if action is required to reduce incoming defect density. This activity takes place after activities 344.8 and 344.9.

344.3B.1 INPUT - Extracted Values Of D_{LAT} , D_{PAT} , k , and CFR

This is the same as output 344.8.3.

344.3B.2 OUTPUT - Determination of D_{IN}

D_{IN} is calculated as the sum of the latent and patent defect content which are values extracted from the fallout analysis (activity 344.8).

344.3B.3 OUTPUT - Determination of $D_{REMAINING}$

$D_{REMAINING}$ is calculated as the difference of incoming defects and number of defects removed where the number of defects removed is found through the fallout analysis (activity 344.8). The value of $D_{REMAINING}$ is later used to determine whether screen strength should be increased or decreased.

344.3B.4 OUTPUT - Required Action to Reduce D_{IN}

D_{IN} is reduced only through corrective actions which reduce further incoming defect density and thereby improve process capability. The observed value of D_{IN} is compared to the planning value to determine whether or not corrective action is necessary.

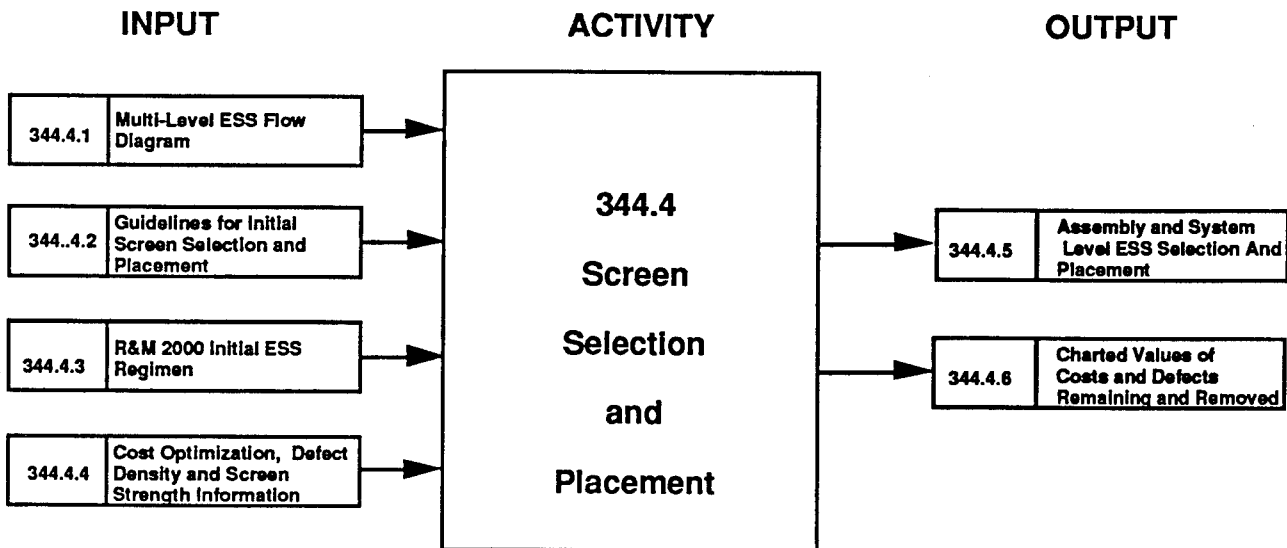

Figure 3.33. Activity 344.4: Screen Selection and Placement

344.4 ACTIVITY - Screen Selection and Placement

This is an iterative process which begins by initially selecting assembly and system level ESS placement and regimen based on recommended handbook (Mil-Hdbk-344A) tables and experience with similar equipment.

344.4.1 INPUT - Multi-level ESS Flow Diagram

This is the same as output 344.2.6.

344.4.2 INPUT - Guidelines for Initial Screen Selection and Placement

Table 4.4 in Mil-Hdbk-344A is recommended as an aid in selecting and placing screens for a starting regimen.

344.4.3 INPUT - R&M 2000 Initial ESS Regimen

Screen types, parameters and placements recommended as initial regimen are outlined in Table 4.5 in Mil-Hdbk-344A.

344.4.4 INPUT - Cost Optimization, Defect Density, and Screen Strength Information

This information comes from Activity 344.7, "Optimization for Cost", Activity 344.3A, "Generate Initial Estimates of Defect Density", Activity 344.3B, "Refine Estimates of Defect Density, and Activity 344.5B, "Refine Estimates of Screen Strength".

344.4.5 OUTPUT - Assembly and System Level ESS Selection and Placement

RV and TC screens are placed at various locations in the ESS model. Guidance for initial selection and placement comes from inputs 344.4.2 and 344.4.3. Modification and improvement of selection and placement comes after data is available as mentioned in input 344.4.4.

344.4.6 OUTPUT - Charted Values Of Costs and Defects Remaining and Removed

The multi-level ESS flow diagram is modified by the addition of cost and remaining and removed defect values. The handbook provides procedures to compute these values. The values are a function of defect density and screen strength.

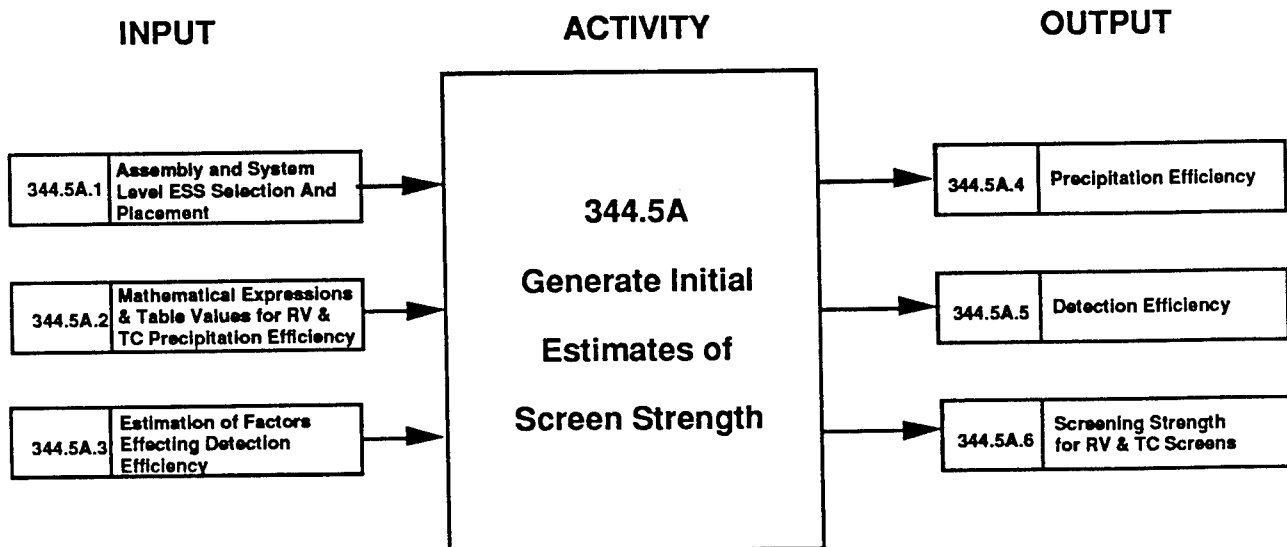

Figure 3.34A. Activity 344.5A: Generate Initial Estimates of Screen Strength

344.5A ACTIVITY - Generate Initial Estimates of Screen Strength

This activity involves the estimation of screen strength for the initial assembly and system level ESS selections.

344.5A.1 INPUT - Assembly and System Level ESS Selection and Placement

This is the same as output 344.4.5.

344.5A.2 INPUT - Mathematical Expressions & Table Values for RV & TC Precipitation Efficiency

Precipitation efficiency is defined as a measure of the capability of a screen to precipitate latent defects to failure. Mil-Hdbk-344A provides equations and tables for computing values of precipitation efficiency based on number of cycles, temperature rate of change and temperature range for temperature cycling and gRMS for random vibration.

344.5A.3 INPUT - Estimation of Factors Effecting Detection Efficiency

Detection efficiency is a measure of the capability of detecting a precipitated latent defect. Mil-Hdbk-344A provides factors and equations for computing detection efficiency based on type of testing performed and conditions during test.

344.5A.4 OUTPUT - Precipitation Efficiency

A value in terms of a probability is determined for each screen.

344.5A.5 OUTPUT - Detection Efficiency

A value of detection efficiency in terms of a probability is determined for each screen.

344.5A.6 OUTPUT - Screening Strength for RV & TC Screens

Screening strength is defined as the probability that a specific screen will precipitate a latent defect to failure and detect it by test. It is the product of precipitation efficiency and detection efficiency.

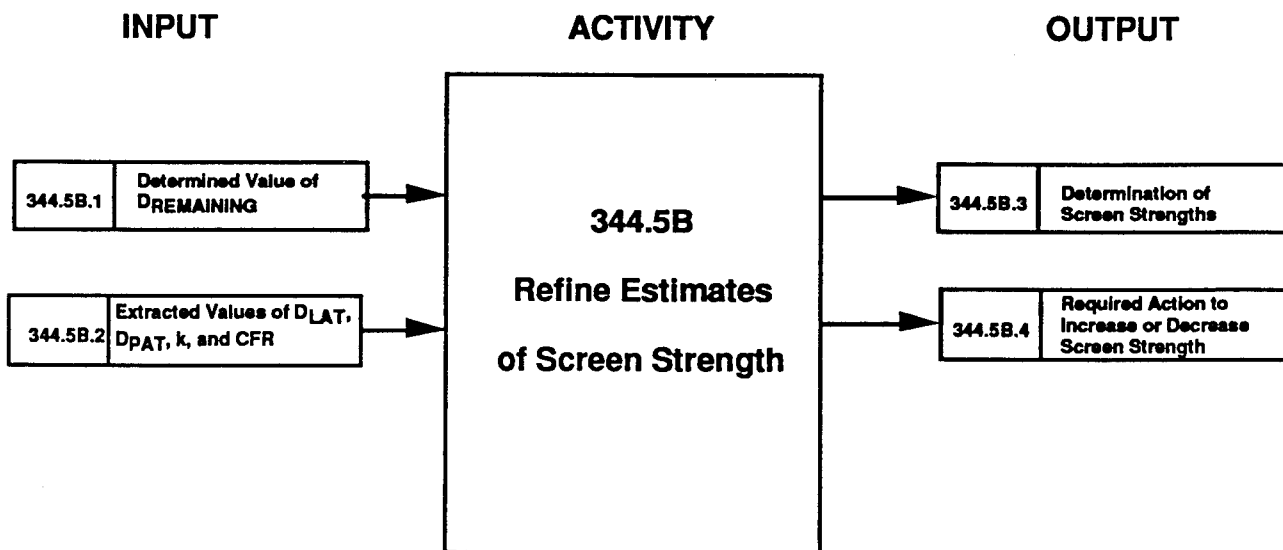

Figure 3.34B. Activity 344.5B: Refine Estimates of Screen Strength

344.5B ACTIVITY - Refine Estimates of Screen Strength

This activity involves the computation of screening strength from the analysis of fallout data. The observed value of $D_{REMAINING}$ is compared to the planning value to determine if screening strength should be increased or decreased. This activity takes place after activities 344.8 and 344.9.

344.5B.1 INPUT - Determined Value of $D_{REMAINING}$

This is the same as output 344.3B.3. This is the "observed" value of $D_{REMAINING}$.

344.5B.2 INPUT - Extracted Values of D_{LAT} , D_{PAT} , k , and CFR

This is the same as output 344.8.3.

344.5B.3 Determination of Screen Strength

Equations are provided within Mil-Hdbk-344A to calculate screening strength from the parameters listed in input 344.6B.2.

344.5B.4 Required Action to Increase or Decrease Screen Strength

Upon determining screening strength, the observed value is compared with the planning value. The same comparison is made with $D_{REMAINING}$. If necessary, screen strength is increased by changing the screen type, stress levels or duration of the screen and by increasing the thoroughness of tests which are performed in conjunction with the screen.

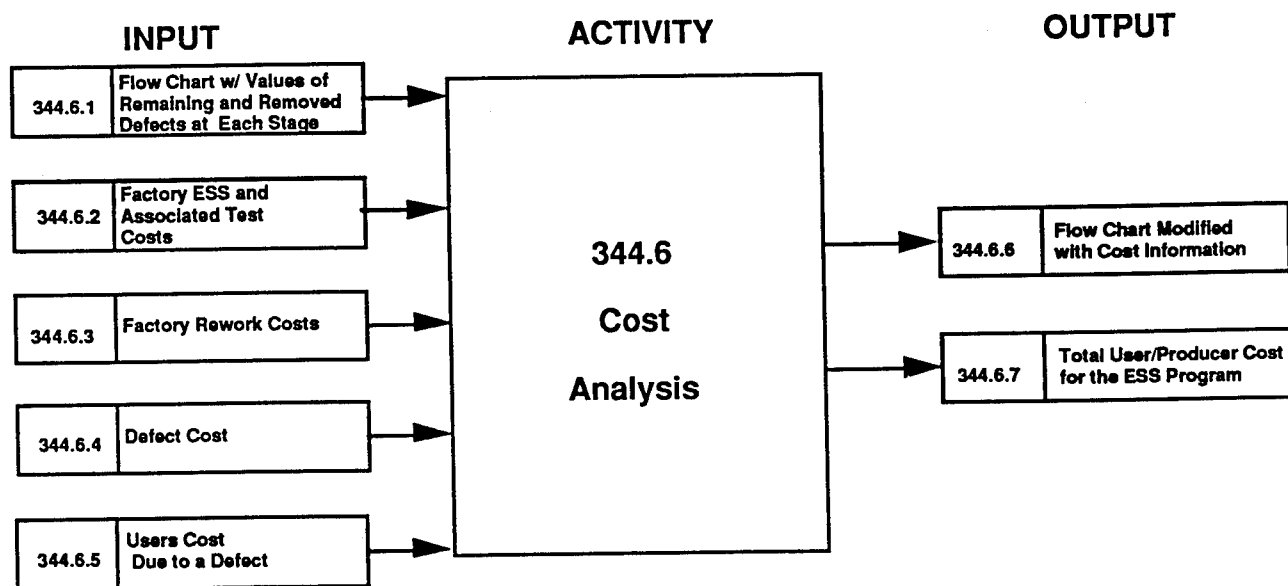

Figure 3.35. Activity 344.6: Cost Analysis

344.6 ACTIVITY - Cost Analysis

This activity involves determining the cost of the ESS program. Cost analysis data is used to modify the program to save money.

344.6.1 INPUT - Flow Chart with Values of Remaining and Removed Defects at Each Stage

This is the same as output 344.4.6.

344.6.2 INPUT - Factory ESS and Associated Test Costs

This includes the cost of all factory ESS and any associated testing which basically consists of equipment and labor costs.

344.6.3 INPUT - Factory Rework Costs

This is the average total cost to repair defects at each stage including diagnostics, rework/repair, retest, repeat ESS, and data recording costs.

344.6.4 INPUT - Defect Cost

The defect cost is determined by multiplying the number of defects at each stage by the cost to repair each defect.

344.6.5 INPUT - Users Cost Due to a Defect

This cost treats the field as an extension of the ESS test flow by determining the users cost associated with a defect.

344.6.6 OUTPUT - Flow Chart Modified with Cost Information

The flow chart consisting of defects remaining and removed values is modified at this point to include the cost associated with screening.

344.6.7 OUTPUT - Total User/Producer Cost for the ESS Program

The total user/producer cost is the sum of inputs 344.6.2, 344.6.3, 344.6.4, and 344.6.5.

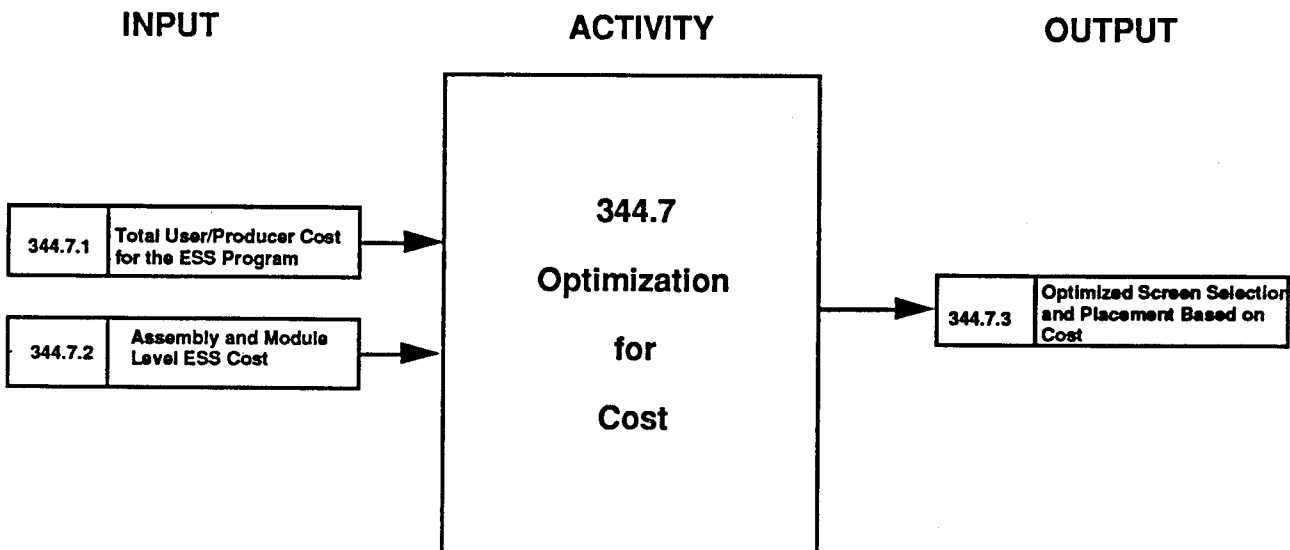

Figure 3.36. Activity 344.7: Optimization for Cost

344.7 ACTIVITY - Optimization for Cost

This activity involves an optimization of the screen selection and placement based on cost.

344.7.1 INPUT - Total User/Producer Cost for the ESS Program

This is the same as output 344.6.7.

344.7.2 INPUT - Assembly and Module Level ESS Cost

The cost associated with ESS is determined for all assemblies and modules. Assemblies and modules with high ESS cost are identified.

344.7.3 OUTPUT - Optimized Screen Selection and Placement Based on Cost

For those assemblies and modules with high ESS cost a lower level ESS placement should be selected. The cost is then recalculated and mathematical verification that field reliability will be achieved is then made using the modeling procedures in the handbook.

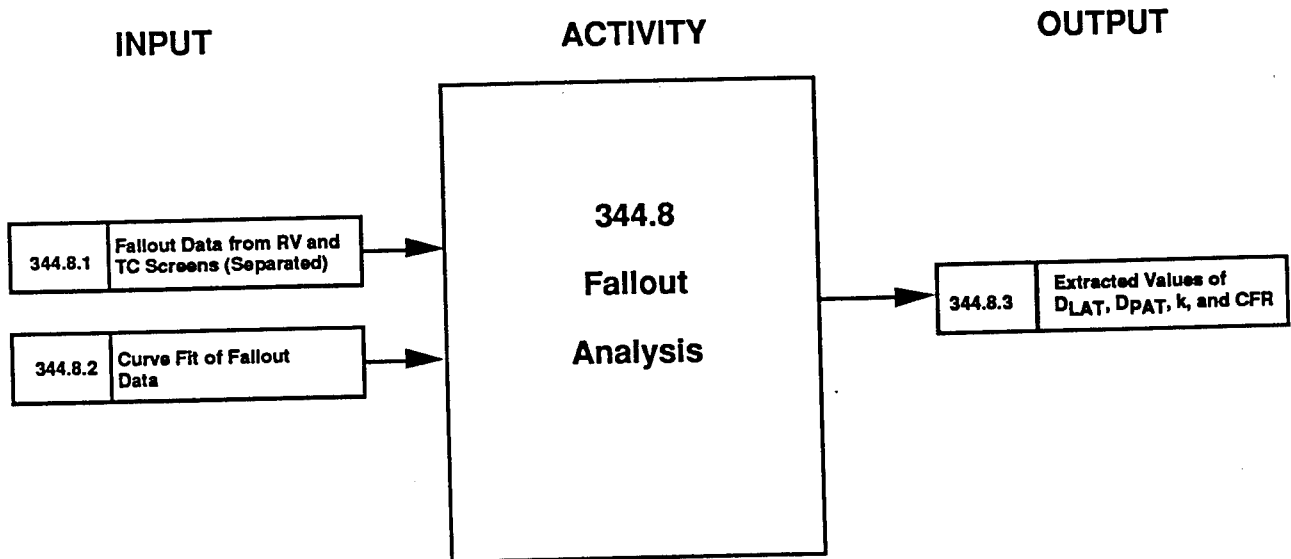

Figure 3.37. Activity 344.8: Fallout Analysis

344.8. ACTIVITY - Fallout Analysis

This activity involves analysis of the fallout data to extract defect density values and other parameters for use to quantitatively modifying screening levels.

344.8.1 INPUT - Fallout Data from RV and TC Screens

The data required should be available from the FRACAS system. This includes fallout data from each type of environment (i.e., TC and RV).

344.8.2 INPUT - Curve Fit of Fallout Data

Graphs should be prepared with the cumulative defects, normalized as defects per system as the ordinate, and the stress duration as the abscissa.

344.8.3 OUTPUT - Extracted Values of DLAT, DPAT, k, and CFR

The handbook provides methods for extracting various required parameters. The parameters required include DPAT - Patent Defect Density, DLAT - Latent Defect Density, k- stress constant, and CFR - Constant Failure Rate. The parameters are later used to compute "observed" values of remaining and initial defect density, and screen strength.

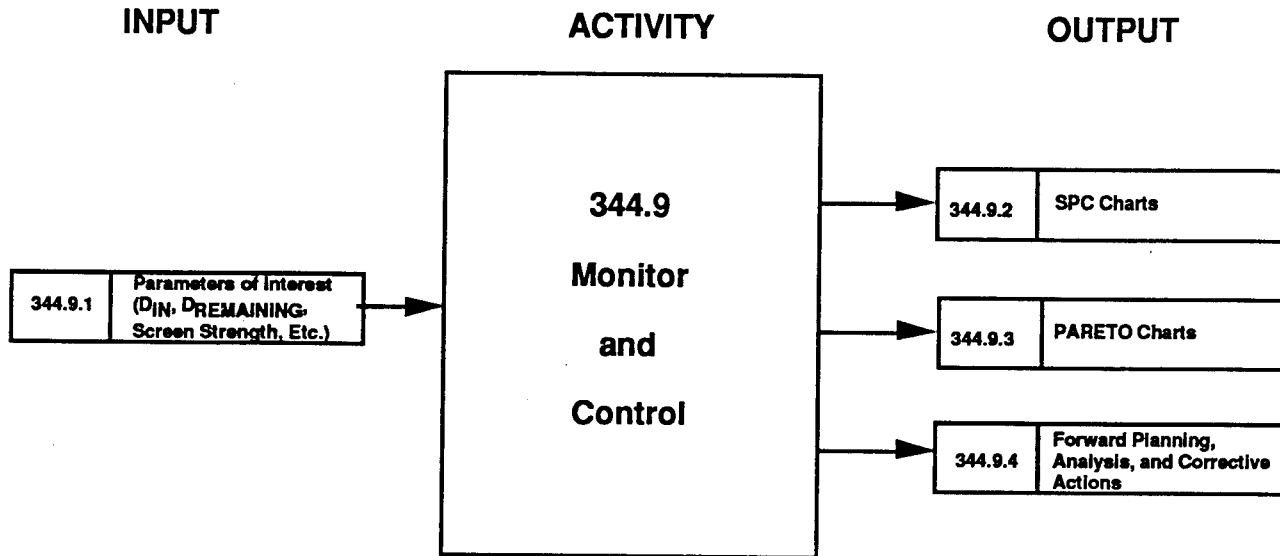

Figure 3.38. Activity 344.9: Monitor and Control

344.9 ACTIVITY - Monitor and Control

This activity involves utilizing modified statistical process control and PARETO charts to monitor parameters of interest against established requirements.

344.9.1 INPUT - Parameters of Interest (DIN, DREMAINING, Screen Strength, Etc.)

The parameters of interest are determined in Activities 344.8, 344.3B, and 344.6B.

344.9.2 OUTPUT - SPC Charts

Statistical process control charts are used to display goals and compare actual results to the goals. When using SPC charts to monitor values of defect density, the charts are different than conventional SPC charts in that the parameter of interest should be improving with time making it necessary to use regression analysis.

344.9.3 PARETO Charts

As a supplement to SPC charts it is sometimes useful to generate a PARETO chart to display a breakdown of failure causes.

344.9.4 Forward Planning, Analysis, and Corrective Actions

Out of control conditions and failure causes should be examined to compare requirements with any variations. The amount of resources required to understand and resolve problems should be determined along with the comparison.

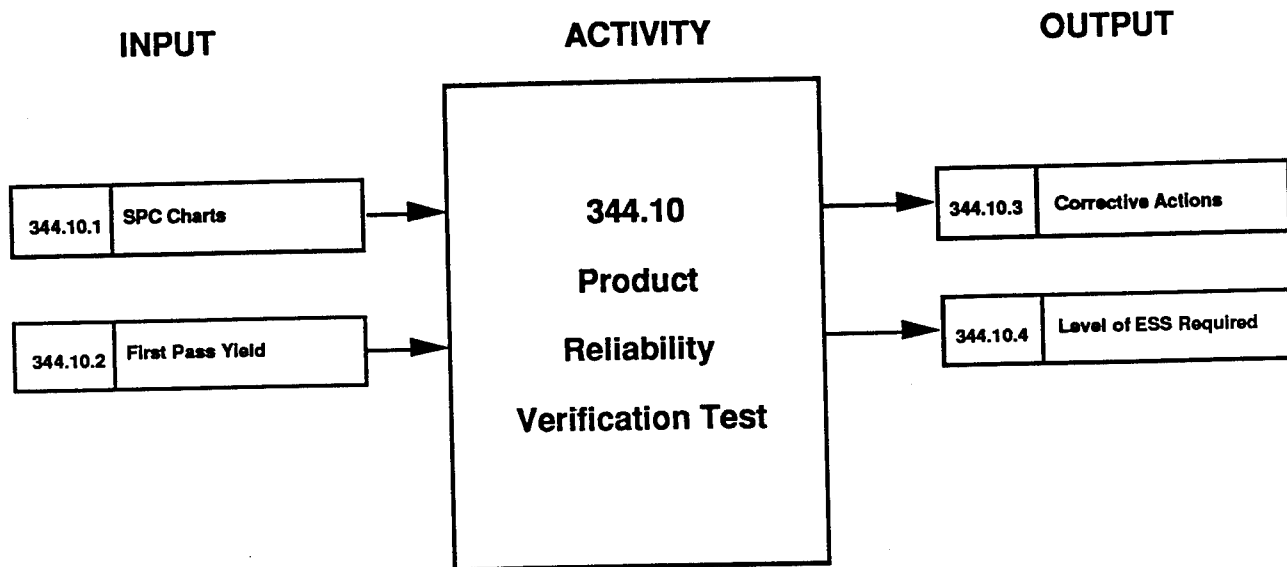

Figure 3.39. Activity 344.10: Product Reliability Verification Test

344.10 ACTIVITY - Product Reliability Verification Test (PRVT)

As defect density is continually reduced, a reduction in ESS is warranted. PRVT is the portion of ESS retained for the purpose of providing a mechanism to indicate if and when the process is out of control and reliability is not being achieved.

344.10.1 INPUT - SPC Charts

This is the same as output 344.9.2.

344.10.2 INPUT - First Pass Yield

This is defined as the number of systems completing the PRVT segment with no failures divided by the total number of systems first time submitted.

344.10.3 OUTPUT - Corrective Actions

If the SPC requirements and the PRVT requirements of first pass yield are not achieved, the outgoing system defect density is too high and corrective action must be taken.

344.10.4 OUTPUT - Level of ESS Required

If the first pass yield is worse than required and the monitor and control techniques of Activity 344.9 indicate problems, ESS should be added according to Mil-Hdbk-344 guidelines. If first pass yield is acceptable, the handbook provides guidance on the minimum necessary ESS required.

3.5 TEOOO-AB-GTP-020A, Environmental Stress Screening Requirements and Application Manual for Navy Electronic Equipment (Dated January 1992)

3.5.1 Discussion of TEOOO-AB-GTP-020A

TEOOO-AB-GTP-020A was prepared by the Naval Sea Systems Command and the Naval Warfare Assessment Center. It defines requirements for equipment and spare contractors and Class A and B depot personnel for conducting ESS during full scale development (FSD), production, and reprourement of new systems, spares, and repaired systems. The guidebook is intended for use by program managers for baseline minimum ESS requirements for contract statements of work (SOWs) and by design and manufacturing engineers and depot repair specialists for implementation. It provides both requirements and application information concerning the implementation of ESS. Much of the guidebook is devoted to part level ESS requirements such as part upgrade screening, minimum quality level screening, and additional part screening (rescreening). In addition to part level screening/additional part requirements, the document sets requirements and contains guidance for temperature cycling and random vibration screening at the PWA and assembly levels. The guidebook doesn't include much in the area of planning, the engineering process of estimating and optimization, and cost analysis.

3.5.2 TEOOO-AB-GTP-020A Process

Figure 3.42 illustrates the top level activities flow of TEOOO-AB-GTP-020A. Figures 3.43 through 3.47 illustrate the individual activities of the process along with their inputs and outputs. Activity and input and output descriptions follow each illustration

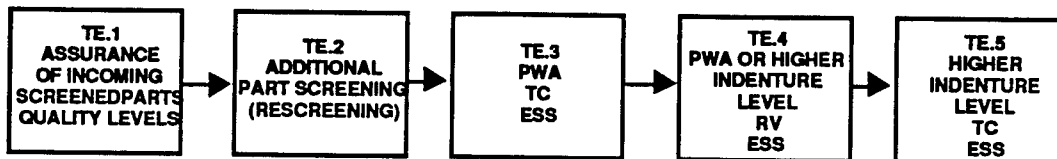

Figure 3.40. TEOOO-AB-GTP-020A Top Level Activities Flow Diagram

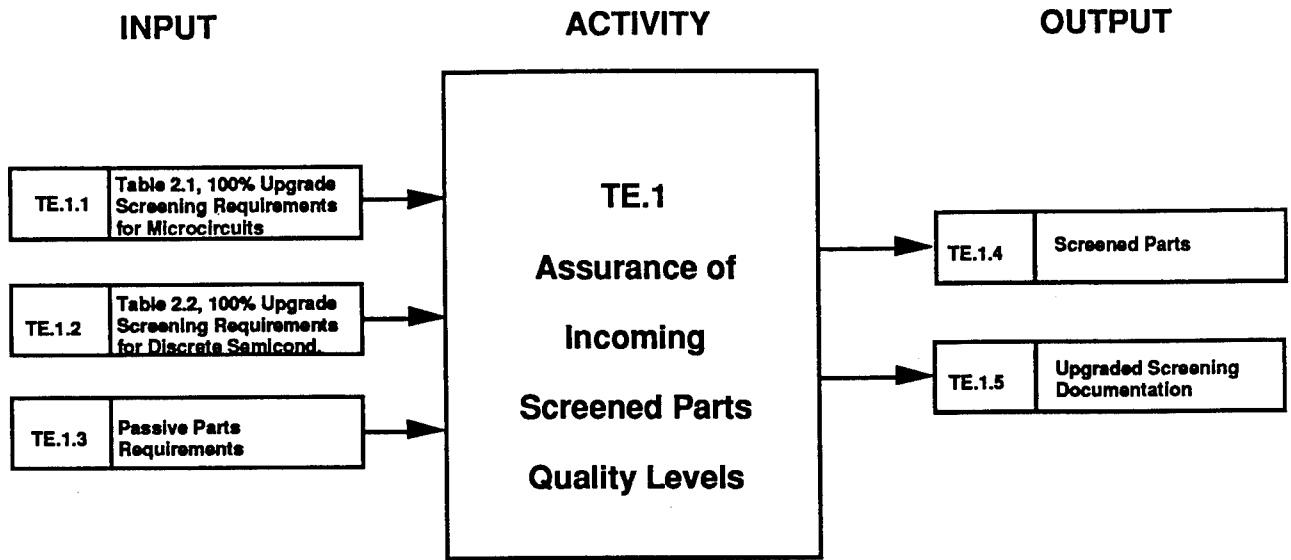

Figure 3.41. Activity TE.1: Assurance of Incoming Screened Parts Quality Levels

TE.1 ACTIVITY - Assurance of Incoming Screened Parts Quality Levels

The guidebook requires that all electrical parts shall be purchased as screened parts to the minimum quality levels as outlined within the book. All other active parts shall be upgrade screened per tables 2.1 and 2.2 of the guidebook. Upgrade screening may be performed by the part manufacturer, an independent testing laboratory, the equipment contractor, the spares contractor, or the depot. Any screens performed by the parts manufacturer do not need to be repeated during upgrade screening.

TE.1.1 INPUT - Table 2.1, 100% Upgrade Screening Requirements for Microcircuits

This table was extracted from Mil-Std-883 Method 5004. It includes criteria for: stabilization bake, temperature cycling, constant acceleration, burn-in test, final electrical test, and hermetic seal.

TE.1.2 INPUT - Table 2.1, 100% Upgrade Screening Requirements for Discrete Semiconductors

This table was extracted from Mil-Std-750 and Mil-S-19500. It includes criteria for: high temperature storage, thermal shock, surge, thermal response, constant acceleration, high temperature, reverse bias, power burn-in, final electrical tests, and hermetic seal.

TE.1.3 INPUT - Passive Parts Requirements

The guidebook requires passive parts to meet, as a minimum, an "Established Reliability" (ER) failure rate level. If these parts do not exist, the contractor is required by the guidebook to use a less reliable ER level as allowed by the contract.

TE.1.4 OUTPUT - Screened Parts

This output includes all parts screened in accordance with the requirements set out in the guidebook. The parts are either screened to the minimum acceptable levels when received or are upgrade screened after purchase.

TE.1.5 OUTPUT - Upgrade Screening Documentation

If upgrade screening is performed by the part manufacturer, the guidebook requires that certification of test and results be provided by the part supplier. If the screening is conducted by an independent lab, the equipment or spares contractor, or the depot, the guidebook requires upgrade screening requirements to be made available to the contracting activity.

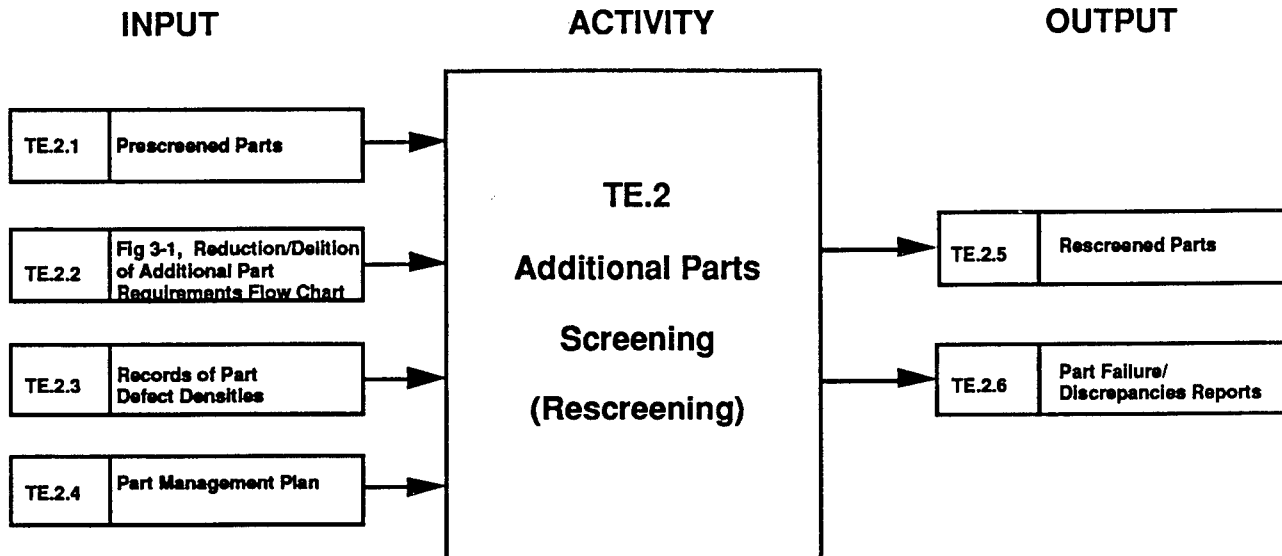

Figure 3.42. Activity TE.2: Additional Parts Screening (Rescreening)

TE.2 ACTIVITY - Additional Parts Screening (Rescreening)

The guidebook recommends that all parts meeting the minimum quality levels and all "upgrade screened parts" shall be considered for rescreening. If the parts have been electrically tested by the equipment contractor, an independent test facility, or a spare/repair depot, it is unnecessary to repeat any of the electrical test requirements on these parts.

TE.2.1 INPUT - Prescreened Parts

This is the same as output TE.1.4.

TE.2.2 INPUT - Figure 3-1, Reduction/Deletion of Additional Part Requirement

The flow chart is used to help determine which of the parts shipped to the Original Equipment Manufacturer (OEM) should be rescreened.

TE.2.3 INPUT - Record of Part Defect Densities

Additional part screening is not necessary (according to the guidebook) if the part defect density is less than 100 PPM.

TE.2.4 INPUT - Part Management Plan

The guidebook recommends that a total and comprehensive part management plan be developed, providing economic and technical justification for effective tailoring.

TE.2.5 OUTPUT - Rescreened Parts

This output consists of all rescreened and tested parts which are stored in the OEMs store room or moved directly to the assembly line.

TE.2.6 OUTPUT - Part Failure/Discrepancies Records

Includes all part failure/discrepancies records related to input TE.2.4.

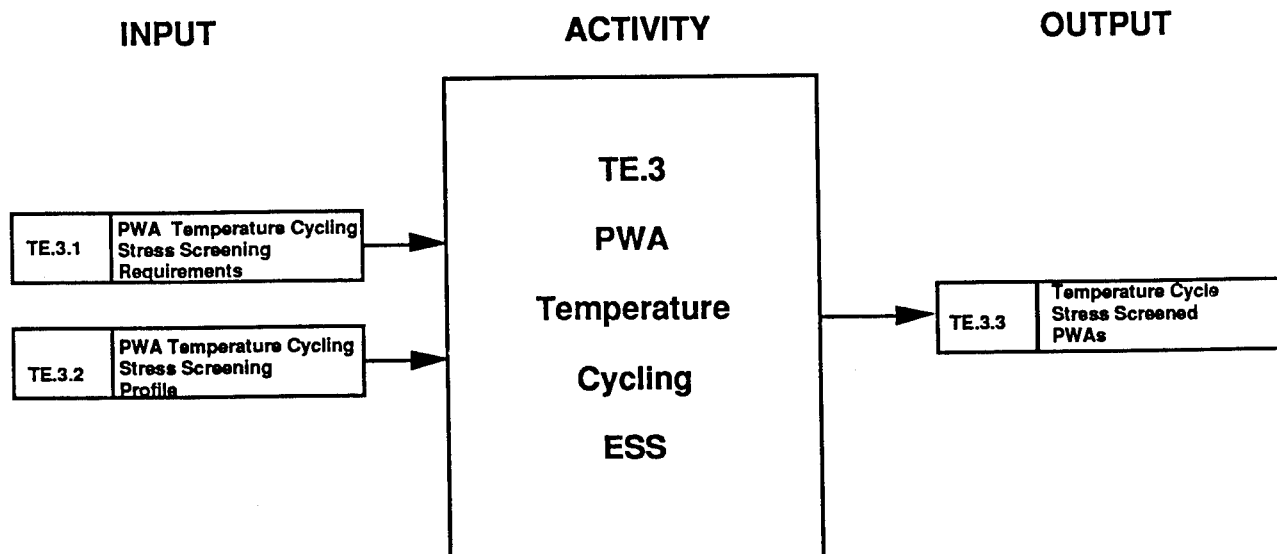

Figure 3.43. Activity TE.3: PWA Temperature Cycling ESS

TE.3 ACTIVITY - PWA Temperature Cycling ESS

This activity involves the implementation of each PWA temperature cycling stress screen. Requirements and specific profiles are contained in the guidebook.

TE.3.1 INPUT - PWA Temperature Cycling Stress Screening Requirements

The guidebook contains requirements for PWA level temperature cycling. The requirements include: number of thermal cycles, temperature range, temperature rate of change, thermal stability, dwell times at temperature limits, failure free temperature cycle, performance monitoring requirements, and power on/off cycle requirements. In addition to the requirements, the guidebook contains fairly detailed temperature cycling application information.

TE.3.2 INPUT - PWA Temperature Cycling Stress Screening Profile

The profile includes the number of thermally induced stress reversals, temperature extremes, and the thermal rate of change of the PWA.

TE.3.3 OUTPUT - Temperature Cycle Stress Screened PWAs

This is the main output of Activity TE.3. The temperature cycle stress screened PWAs will either be assembled to a higher indenture level of assembly or will receive random vibration stress screening.

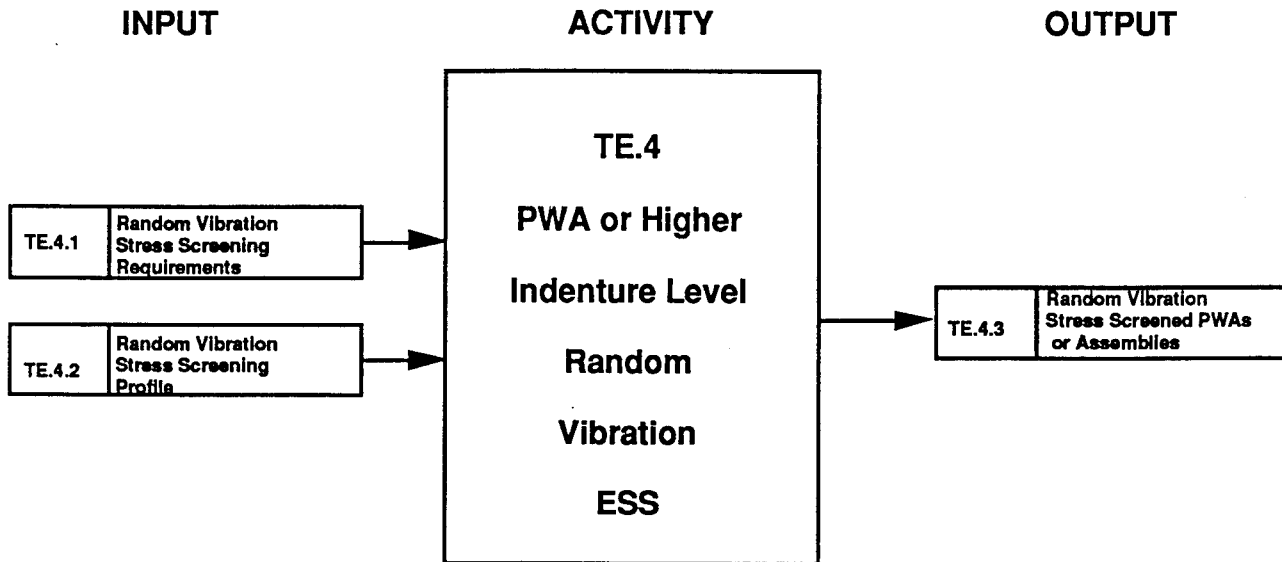

Figure 3.44. Activity TE.4: PWA or Higher Indenture Level Random Vibration ESS

TE.4 ACTIVITY - PWA or Higher Indenture Level Random Vibration ESS

This activity involves the random vibration stress screening of each PWA that has been screened as per temperature cycling requirements of Activity TE.3. This activity also includes the random vibration screening of higher levels of assembly above the PWA level.

TE.4.1 INPUT - Random Vibration Stress Screening Requirements

The guidebook contains requirements for PWA or higher indenture level random vibration stress screening. These include acceleration response spectrum, input stimulus, indenture level, number of axes, and duration.

TE.4.2 INPUT - Random Vibration Stress Screening Profile

The guidebook recommends the determination of an optimum profile. A simple engineering analysis method is contained within the book. The methodology is based on determining the maximum allowable power spectral density level by calculating the input profile on actual hardware.

TE.4.3 INPUT - Random Vibration Stress Screened PWAs or Assemblies

PWAs completing this phase of random vibration stress screening will be assembled to higher indenture levels. Higher indenture assemblies will receive the next phase of temperature cycling stress screening.

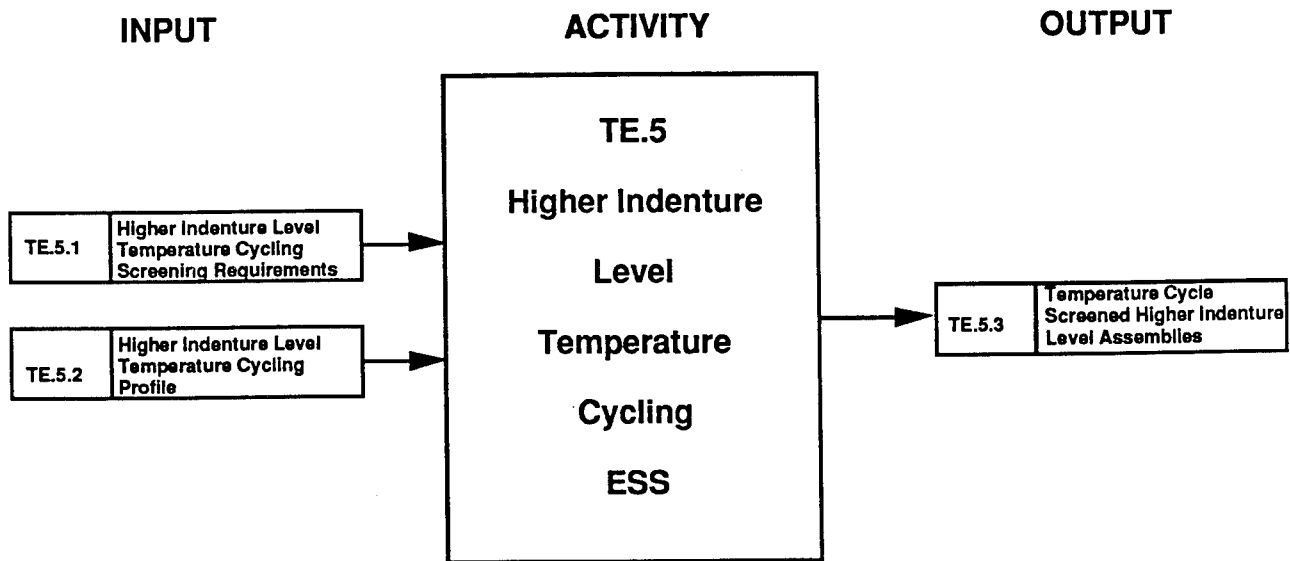

Figure 3.45. Activity TE.5: Higher Indenture Level Temperature Cycling ESS

TE.5 ACTIVITY - Higher Indenture Level Temperature Cycling ESS

This activity involves temperature cycling stress screening at levels of assembly higher than the PWA.

TE.5.1 INPUT - Higher Indenture Level Temperature Cycling Screening Requirements

The guidebook provides requirements for higher level temperature cycling screening. The requirements vary depending on the development phase. There are three sets of requirements: Full Scale Development, Production, and Recprocurement/Spares/Repair (When not proceeded by PWA Thermal Cycling). The book also contains separate application information.

TE.5.2 INPUT - Higher Indenture Level Temperature Cycling Profile

This is basically the same as output TE.3.2 with some minor modifications.

TE.5.3 OUTPUT - Temperature Cycle Higher Level of Indenture Assemblies

This is the main output of this activity. It includes an assembly or equipment which will receive final acceptance test.

3.6 Summary Of Other Equipment/Assembly Level ESS Guidebooks

This section provides brief descriptions of other equipment/assembly level ESS guidebooks that are in existence. The discussions attempt to overview the books and not to pass judgment as to their validity or worth. These documents were not selected for detailed process descriptions because the five selected provided a more than adequate coverage of important ESS tasks/activities.

AFP 800-7, "USAF R&M 2000 Process", Dated 1 January 1989

Preparing Activity: Former Air Force/Air Staff R&M 2000 Office (AF/LERD)

The "USAF R&M 2000 Process" pamphlet was written to outline the various R&M practices used to improve product quality and combat readiness. One of the practices contained is "R&M 2000 Environmental Stress Screening". AFP 800-7, Appendix B outlines general guidelines and requirements for ESS of electronic equipment. The guidelines and requirements have become very popular and were reproduced in many of the published ESS guidance documents. In total, the guidelines only consist of three pages of text. The first page includes a list of nine general requirement like guidelines. The second page outlines an ESS baseline regimen for both thermal cycling and random vibration screening. The third page contains notes relative to tailoring the initial regimens.

MIL-STD-2164(EC), "Environmental Stress Screening Process For Electronic Equipment", Dated 5 April 1985

Preparing Activity: Naval Electronics Systems Center

MIL-STD-2164(EC) is the only ESS guidebook with "ESS" in the title that is an actual military standard. The standard contains rigid requirements for conducting screening programs on electronic equipment. General requirements are contained for test conditions, test facilities, instrumentation ground rules, performance monitoring, failure reporting analysis and corrective system (FRACAS), and sampling. Detailed requirements are provided for random vibration and thermal cycling environmental stresses, total ESS test program, and final functional operational test. ESS experts have criticized this document as being too rigid in setting specific requirements and not fostering a flexible/innovative ESS program. Two background appendices are provided. One appendix provides theory and rationale for how specific test requirements were determined in the standard. The second appendix discusses considerations for troubleshooting ESS failures.

AMC Reg. No. 702-25, "AMC Environmental Stress Screening Program", Dated 29 May 1987

Preparing Activity: Army Materiel Command (AMC)

The intent of AMC 702-25 is to provide guidance for implementing ESS programs for electronic, electrical, or electromechanical Army materiel acquisitions. A number of policies are listed with respect to AMC ESS intentions, planning, training,

reporting, corrective action program, and implementation. Procedures are explicitly spelled out for implementation of ESS programs. Responsibilities are outlined for specific AMC personnel to adhere to. As an example, "The Deputy Chief of Staff for Product Assurance and testing, will. . .". An appendix is included with guidelines for preparing the ESS portion of a statement of work.

"Warner Robin Air Logistics Center (WR-ALC) Environmental Stress Screening (ESS) Handbook", Dated February 1990

Preparing Activity: WR-ALC/Directorate Of Materiel Management

The WR-ALC handbook is intended to provide guidance for incorporating ESS into "purchase requests". The book is based on many of the principles of AFP 800-7, "USAF R&M 2000 Process". General information is provide including definitions and characteristics of ESS. Application guidelines are listed for equipment conditions during ESS, desired screening setups, equipment monitoring, etc. Tailoring guidance is contained within the book which fosters flexibility in setting up ESS programs. Tailoring here refers to how random vibration and thermal cycling regimens are set up. The tailoring techniques discussed include step stress analysis, previous experience, strength models, and total time on test. Provisions for contractual ESS are also found. These include guidelines for writing specification language, statements of work, and contract deliverable data requirements. A specification example is found in Appendix A and a statement of work example with contractor data requirement forms in Appendix B. Detailed guidance for a contractor submitted ESS implementation plan is also contained within the book. Excerpts from the AFP 800-7 document for initial regimen levels and Mil-Std-781D task 401 are also reproduced in the document.

"Sacramento Air Logistics Center Environmental Stress Screening Handbook", Dated 15 June 1988

Preparing Activity: SM-ALC/Directorate Of Material Management

SM-ALC prepared this document for use by engineers, program managers and anyone else required to implement ESS in either the repair or acquisition process. The book is also based on the AFP 800-7, "USAF R&M Process" approach. It is also very similar in structure to the WR-ALC handbook. General ESS information including definitions and characteristics are found in the early part of the book. General guidelines are provided for specifying requirements, equipment conditions, regimens, facilities, performance monitoring and incoming part defect density levels. Planning guidelines are found for ESS during the production, design and early repair phases. Tailoring guidelines very similar to the WR-ALC handbook are also included. The techniques included are surveys, step-stress analysis, previous contractor experience, strength models and total time on test. Specific personnel responsibilities are also spelled out for branch chiefs, engineers and equipment specialists along with miscellaneous joint responsibilities. A good deal of "contracting for ESS" guidance is also included. Specifically, provisions for designing an effective ESS program, ESS certification, and organic manufacturing and repair ESS. In a fashion similar to the WR-ALC handbook, this book guides the user through the specification requirements

and statement of work generation activities. Specification, SOW, and deliverable item examples are also provided.

DoD 4245.7-M, "Transition From Development To Production" Dated September 1985 (with follow-on document NAVSO P-6071, "Best Practices" Dated March 1986

Preparing Activity: Defense Science Board Task Force, Chaired By Navy's W.J. Willoughby

The original of the two documents (DOD 4245-7-M) was intended to provide guidance in structuring DOD acquisition programs. It identifies the various engineering related disciplines or "templates" inherent to a quality product development. Manufacturing screening is one of these templates. Risks associated with the various templates and risk mitigation techniques are discussed. The follow-on (Best Practices) identifies potential "traps" associated with each template that a program could become subjected to. The current practices and their problems are outlined. Proven best practices for avoiding the traps are discussed. The ESS guidance is philosophical in nature and is only 3 pages in length. The two books outline many of the important aspects of ESS and help to show how it is tied to the overall system acquisition process.

Mil-Std-781, "Reliability Testing for Engineering Development, Qualification, and Production" (with companion document Mil-Hdbk-781, "Reliability Test Methods, Plans, and Environments for Engineering Development, Qualification, and Production") dated Jul. 1987

Preparing Activity: Space And Naval Warfare Systems Command

Mil-Std-781D is used to specify the general requirements and specific tasks for all types of reliability testing during the development, qualification, and production of systems and equipment. The ESS task (Task 401) provides administrative guidance on the formulation of a contractor's ESS program. The following details to be specified by the procuring activity are identified as essential: Specification of random vibration power spectral density curve, specification of thermal profile for temperature cycling, specification of number of hours (cycles) for ESS, imposition of Mil-Std-785, Task 104 (FRACAS) as a prerequisite task. Mil-Hdbk-781 is designed to be used with Mil-Std-781. The test methods, test plans, and environmental profile data are presented in a manner which facilitates their use with the tailorable tasks of Mil-Std-781. The handbook contains some discussion on three ESS monitoring methods. Namely, the computed ESS time interval method, the graphical method, and the standard ESS method.

Mil-Hdbk-338, "Electronic Reliability Design Handbook, dated Oct. 1988

Preparing Activity: Rome Laboratory, USAF

Mil-Hdbk-338 is one of the most comprehensive handbooks ever published in the area of Reliability. The ESS portion contains both administrative and technical guidance on setting up and conducting ESS. The document contains some of the early quantitative methodology that eventually evolved into Mil-Hdbk-344.

4.0 Summary and Recommendations

4.1 Summary

This study has resulted in the development of an improved environmental stress screening (ESS) process for electronic equipment. The application of a quality management tool, namely process analysis, to the reliability task of ESS was proven successful and beneficial. The major contributions of this work are the process descriptions found in Chapter 2. Detail process descriptions were defined and documented for both quantitative and classical ESS approaches. Differentiating between the two approaches was a logical way to study and improve upon ESS from a process perspective. ESS practitioners could use the process descriptions to structure and manage well defined ESS programs. ESS researchers could use the processes to continually improve ESS. The process descriptions could also be used as a training/educational tool. It was necessary to define and document process descriptions for five popular ESS guidebooks (Chapter 3). This was an important step in the development of the improved classical and quantitative processes. The stand-alone process descriptions of Chapter 3 are significant contributions in their own right. They can be used to continuously improve upon the individual guidebooks from where they were extracted.

4.2 Recommendations

Future research is recommended to address the following areas:

- A. Automation of Environmental Stress Screening Process/Activities - An automated ESS tool would be very useful to the manufacturing and reliability communities. The process descriptions found in this document could serve as a baseline for the software development. The first step would be to develop software requirements based on the process descriptions. It would be ideal to have an all encompassing ESS tool that implemented both the quantitative and classical approaches and was tied to the important related activities of failure reporting and corrective action system (FRACAS) , continuous improvement of manufacturing processes and final reliability acceptance testing procedures
- B. ESS In a Concurrent Engineering Environment - Linking the process descriptions documented in this book to the other engineering disciplines would be a logical follow-on to this study. Many companies are now explicitly defining and documenting their engineering processes including ties between the various disciplines. Process description is a valuable tool for implementing concurrent engineering.
- C. More Detailed ESS Process Description - The process description technique used in this report included a top level activity flow diagram and individual activity descriptions with inputs and outputs to the activities explained. It would be beneficial to take the process description down one level further by showing more detailed descriptions of each input and output. Each input and output could be treated as an activity in their own right by illustrating and explaining their inputs and outputs.

D. Continuous ESS Process Improvement - The quantitative and classical processes depicted in this report are only the beginning of ESS process improvement. The processes could be continuously improved indefinitely. A team of ESS experts other than the authors could review the processes and come up with recommendations for further improvement.

E. Improvement of Individual ESS Guidebooks - The guidebooks looked at for this study could be improved by incorporating some of the findings documented here. Long term plans for Rome Laboratory ESS personnel are to use this document to improve on the procedures documented in Mil-Hdbk-344A.

Appendix A

An Improved/Easier to Use Mil-Hdbk-344A Calculation Procedure

This appendix provides a quick and easy way to perform the computations associated with the quantitative procedures outlined in Mil-Hdbk-344A. Based on user comments relative to Mil-Hdbk-344A, it can be cumbersome to use. This appendix will ease the use of the handbook. Figure A-1 is a flow chart which steps through a sequence of required parameters for use with the handbook. Table A-1 provides instructions on how to compute or arrive at the parameters. This procedure should be used in conjunction with the handbook. It is not a stand alone procedure. The material presented here will be used to improve the handbook for the next revision. It may also be used to form the basis for automation of the quantitative procedures outlined in Mil-Hdbk-344A.

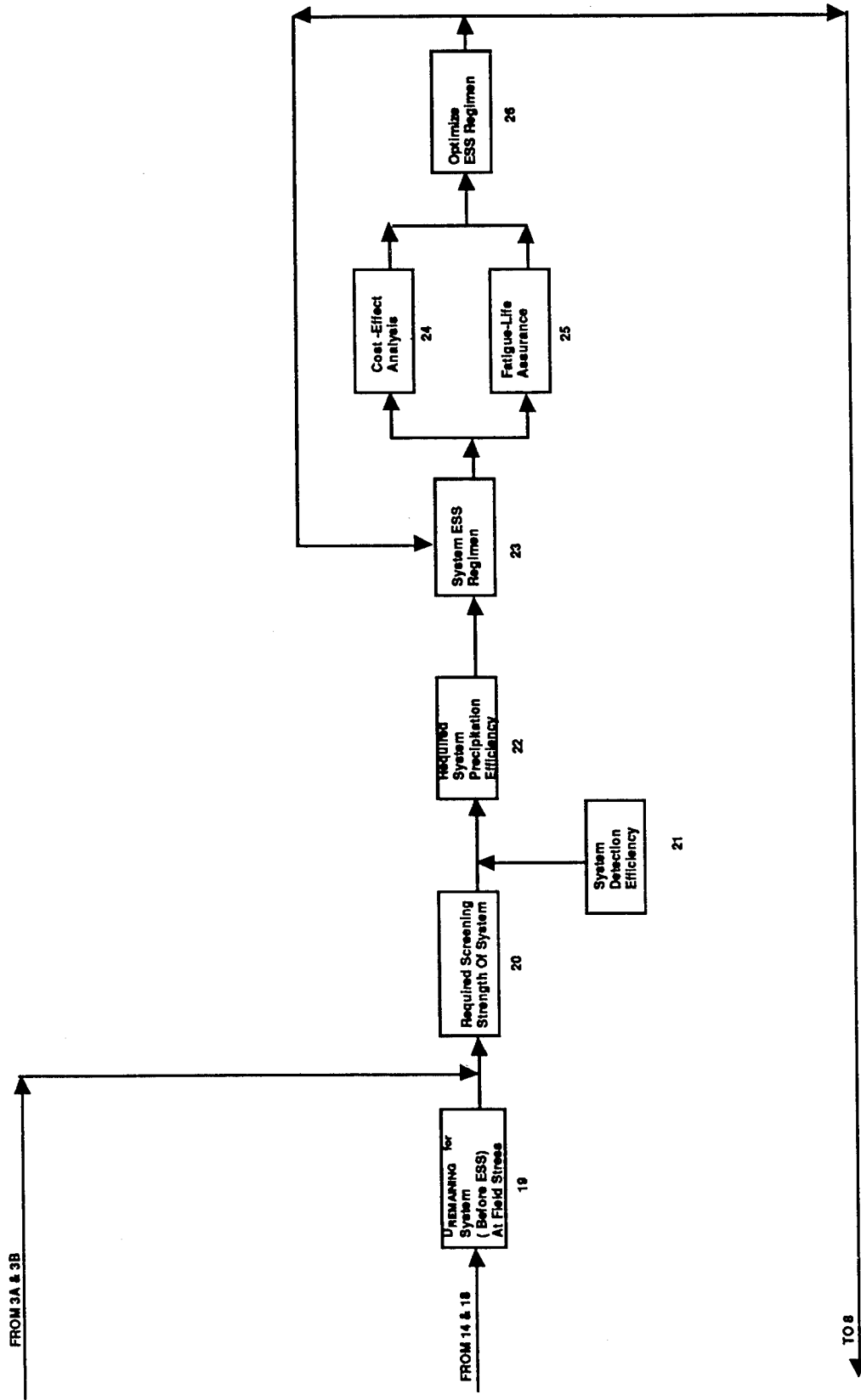

Figure A.1. Quantitative ESS Calculation Flow Chart (Activities Prior To Actual Production Screening) (Continued)

Table A-1. Mil-Hdbk-344A Parameter Computations

NO.	DESCRIPTION	FORMULA	REQUIRED TABLE	REQUIRED FIGURE TO COMPLETE	REMARKS
1A	Required & Inherent MTBF	--	--	--	Mil-Hdbk-344A Section 5.2.3 Procedure A1, Step 5
2A	Failure Rate Due To Latent Defects (FR)	$FR_s \left(\frac{1}{\text{Required MTBF}} \cdot \frac{1}{\text{Inherent MTBF}} \right) \times \frac{1}{\text{Safety Margin}}$	--	--	Safety Margin allows for estimation errors, typical values are 1.5 to 2.0
3A	Maximum Allowable Remaining Defects At Field Stress Level (D GOAL)	$D_{GOAL} = \frac{(2A) \cdot t}{1 - \exp(-kt)}$ <p>2A: Result of No. 2A above k: Field Precipitation Rate, Typical Value = 1/500 to 1/2000 t: The period over which MTBF is to be measured</p>	--	--	Mil-Hdbk-344A, Section 5.2.3, Procedure A1, Step 5
1B	Predicted Or Inherent (P) And Specified (S) MTBF	--	--	--	IES ESS Guidelines For Assemblies Method 2, A1.4
2B	Target (T) MTBF	$T = S + 0.25(P - S)$	--	--	
3B	Maximum Allowable Defects (D GOAL)	$D_{GOAL} = \frac{P}{T} \cdot 1$	--	--	
4	System And Unit Breakdown Charts	--	Mil-Hdbk-344A Fig. 5.3 & 5.4	--	--
5	Assembly Complexity Vectors	--	--	Mil-Hdbk-344A Fig 5.5 & 5.6	Mil-Hdbk-344 Section 5.3 Procedure B
6	Defect Density Of Each Assembly At Baseline Stress $D_{jN(i)}$: Defect Density of Assembly i at Baseline Stress	$D_{jN(i)} = \sum_{j=1}^n \text{Def Den}(j) \times \text{Quantity}(i)$ <p>DefDen: Defect Density of Part or manufacturing characteristic type j from Mil-Hdbk-344A, Table 5.1 Quantity: Quantity of part or manufacturing characteristic type j in assembly i (from No. 5 above) n: total number of part and manufacturing characteristic types in assembly i.</p>	Mil-Hdbk-344A Table 5.1	Mil-Hdbk-344A Fig. 5.5 & 5.6	Mil-Hdbk-344 Section 5.3 Procedure B

Table A-1. Mil-Hdbk-344A Parameter Computations (Continued)

NO.	DESCRIPTION	FORMULA	REQUIRED TABLE	REQUIRED FIGURE TO COMPLETE	REMARKS
7	Proportion Of RV & TC Susceptible Defects	Proportion each assembly's defects into RV and TC sensitive percentages using the ratio 20% RV, 80% TC or other suitably determined ratio.	--	Mil-Hdbk-344A Figs 5.2 & 5.2A	Mil-Hdbk-344A Section 5.2.3 Procedure A1, Step 1
8	ESS Regimen Assignment for Each Assembly	--	Mil-Hdbk-344A Tables 4.4 & 4.5	Mil-Hdbk-344A Figs 5.2 & 5.2A	Proper screen selection and placement for each assembly RV: GRMS: duration TC: # of cycles, min & max temp, rate of change, dwell duration
9	Precipitation Efficiency of Each Assembly's ESS Regimen PE(i): Precipitation Efficiency of Assembly i	Method 1: (Formula Computation) $PE(i) = 1 - \exp(-kt)$ TC: $k = 0.0017(\Delta T + .6)^6 [\ln(\text{Rate} + 2.718)]^3$ t = # of cycles RV: $k = 0.0046G^{1.71}$ t = duration Method 2: Determine Using Table 5.14-5.17 of Mil-Hdbk-344A	Mil-Hdbk-344A Tables 5.14 - 5.17	--	Mil-Hdbk-344A, Section 5.4.3, Step 1
10	Detection Efficiency for Each Assembly DE(i): Detection Efficiency for Assembly i	DE is the product of three parameters DE = (testing parameter) X (environmental conditions during test parameter) X (probability of detecting, isolating and removing the defect)	--	--	Mil-Hdbk-344A, Section 5.4.3, Step 2
11	Screening Strength [SS(i)] of Each Assembly	$SS(i) = PE(i) \times DE(i)$	--	Mil-Hdbk-344A, Figs 5.2 & 5.2A	SS of RV and TC should be calculated separately
12	DREMAINING of each assembly or unit (level immediately below system) DREMAINING (i): DREMAINING of Assembly i	$DREMAINING(i) = SS(i) \times D_{IN}(i)$ $D_{IN}(i) =$ The result of No. 6 above	--	Mil-Hdbk-344A Figs 5.2 and 5.2A	DREMAINING of RV and TC should be calculated separately

Table A-1. Mil-Hdbk-344A Parameter Computations (Continued)

NO.	DESCRIPTION	FORMULA	REQUIRED TABLE	REQUIRED FIGURE TO COMPLETE	REMARKS
13	Yield & ESS Cost Of Each Assembly	$\text{Yield}(i) = \exp(-D \text{ REMOVED}(i))$ $D \text{ REMOVED}(i) = D_{IN}(i) - D \text{ REMAINING}(i)$ $\text{ESS Cost} = \text{Factory Test Cost} + \text{Factory ESS Cost} + \text{Factory Rework Cost}$	-	Mil-Hdbk-344A, Figs 5.2 & 5.2A	-
14	D REMAINING For System At baseline Stress (D _{RMsb}) (Before Actual ESS)	$D_{RMsb} = \sum_{i=1}^m D \text{ REMAINING}(i) + (\text{Assembly defects that will occur during system integration})$ <p>Here, D REMAINING is calculated at the level immediately below the system level, i.e. unit or assembly level. (From 12 above)</p> <p>m: number of units or assemblies</p>	-	Mil-Hdbk-344A, Figs 5.2 & 5.2A	-
15	System Complexity Vector	Summation of all the assembly complexity vectors (NO. 5 above)	-	Mil-Hdbk-344A, Figs 5.7 & 5.8	-
16	System Defect Density at baseline stress level (D _{sb})	$D_{sb} = \sum_{j=1}^n \text{Def Den}(j) \times \text{Quantity}(j)$ <p>Def Den(j): Defect Density of Part or manufacturing characteristic type j. From Mil-Hdbk-344A, Table 5.1</p> <p>Quantity(j): Quantity of part or manufacturing characteristic type j in the system (From No. 15 above)</p> <p>n: total number of part and manufacturing characteristic types in the system</p>	Mil-Hdbk-344A, Table 5.1	-	-
17	System Defect Density at field stress level (D _{sf})	$D_{sf} = \sum_{j=1}^n \text{Def Den}(j) \times \text{Quantity}(j)$ <p>Def Den(j): Defect Density of part or manufacturing characteristic type j from Mil-Hdbk-344A, Tables 5.2 - 5.13</p> <p>Quantity & n: Same as NO. 16 above.</p>	Mil-Hdbk-344A, Tables 5.2 - 5.13	-	-

Table A-1. Mil-Hdbk-344A Parameter Computations (Continued)

NO.	DESCRIPTION	FORMULA	REQUIRED TABLE	REQUIRED FIGURE TO COMPLETE	REMARKS
18	Stress Adjustment Factor (SAF)	$SAF = \frac{D_{sf}}{D_{sb}}$	-	-	--
19	D REMAINING Before ESS at Field Stress (DRMSf)	$DRMSf = SAF \times D_{RMSb}$	-	-	--
20	Required Screening Strength of System (SS)	$SS = \frac{DRMSf - D_{goal}}{DRMSf}$	-	Mil-Hdbk-344A Figs 5.2 & 5.2A	--
21	System Detection Efficiency (DE)	Same As NO. 10 above except here it is for system level	-	-	--
22	Required System Precipitation Efficiency (PE)	$PE = \frac{SS}{DE}$	-	-	--
23	System ESS Regimen	Determine appropriate system ESS Regimen Given PE of NO. 22 above and Mil-Hdbk-344A Tables 5.14 - 5.17 RV: GRMS, duration TC: Temperature Range, Rate, No. of cycles	-	Mil-Hdbk-344A Tables 5.14 - 5.17	--
24	Cost - Effect Analysis	$Cost - Effect = \frac{User Cost}{Producer Cost for ESS}$	-	-	Refer to Mil-Hdbk-344A Section 5.2.3, Procedures A2 & A3
25	Fatigue-Life Assurance	$D = NSB$ D: Damage Index N: Number of cycles (TC) Duration Of Vibration (RV) S: Temperature Range(TC) GRMS (RV) B: 2.5 (Thermal Fatigue) 6.4 (Vibration Fatigue)	-	-	Refer To Mil-Hdbk-344A Section 5.2.3, Procedure A4
26	Optimize ESS Regimen	Readjustment of NO. 23 above taking results of NO. 24 & 25 above into consideration. Start from lowest level of assembly and highest ESS cost.	-	Mil-Hdbk-344A Figs 5.2 & 5.2A	--

Appendix B

Bibliography

Air Force Pamphlet 800-7, "USAF R&M 2000 Process"

Army Material Command (AMC) Regulation 702-25, "AMC Environmental Stress Screening Program"

DoD 4245.7-M, "Transition from Development to Production"

Institute of Environmental Sciences, "Environmental Stress Screening Guidelines for Assemblies"

Mil-Hdbk-344A, "Environmental Stress Screening of Electronic Equipment"

Mil-Hdbk-338-1A, "Electronic Reliability Design Handbook", Volume 1

Mil-Hdbk-781, "Reliability Test Methods, Plans, and Environments for Engineering Development, Qualification and Production"

Mil-Std-781, "Reliability Testing for Engineering Development, Qualification, and Production"

Mil-Std-2164, "Environmental Stress Screening Process for Electronic Equipment"

NAVMAT P-9492, "Navy Manufacturing Screening Program"

NAVSO P-6071, "Best Practices"

RL-TR-91-300, "Evaluation of Quantitative Environmental Stress Screening (ESS) Methods", Vols. 1 & 2

RL-TR-93-209, "A Quality Process Approach to Electronic System Reliability"

Sacramento Air Logistics Center (SM-ALC), "Environmental Stress Screening Handbook"

TE000-AB-GTP-020A, "Environmental Stress Screening Requirements and Application Manual for Navy Electronic Equipment"

Tri-Service Technical Brief 002-93-08, "Environmental Stress Screening Guidelines",

***MISSION
OF
ROME LABORATORY***

Mission. The mission of Rome Laboratory is to advance the science and technologies of command, control, communications and intelligence and to transition them into systems to meet customer needs. To achieve this, Rome Lab:

- a. Conducts vigorous research, development and test programs in all applicable technologies;
- b. Transitions technology to current and future systems to improve operational capability, readiness, and supportability;
- c. Provides a full range of technical support to Air Force Materiel Command product centers and other Air Force organizations;
- d. Promotes transfer of technology to the private sector;
- e. Maintains leading edge technological expertise in the areas of surveillance, communications, command and control, intelligence, reliability science, electro-magnetic technology, photonics, signal processing, and computational science.

The thrust areas of technical competence include: Surveillance, Communications, Command and Control, Intelligence, Signal Processing, Computer Science and Technology, Electromagnetic Technology, Photonics and Reliability Sciences.