

THE CAS DISTRIBUTION PROCESS:

**Should the Corps Commander have Direct
Command OF USAF Assets?**

**A Monograph
by**

**Major Gary R. Schamburg
Infantry**

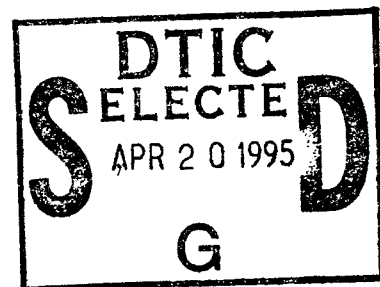
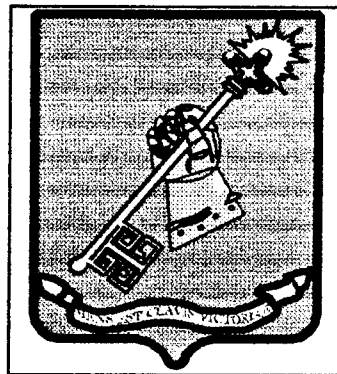

**School of Advanced Military Studies
United States Army Command and General Staff College
Fort Leavenworth, Kansas**

First Term AY 94-95

Approved for Public Release; Distribution is Unlimited

19950419 073

DTIC QUALITY INSPECTED 5

REPORT DOCUMENTATION PAGE			Form Approved OMB No. 0704-0188	
Public reporting burden for this collection of information is estimated to average 1 hour per response, including the time for reviewing instructions, searching existing data sources, gathering and maintaining the data needed, and completing and reviewing the collection of information. Send comments regarding this burden estimate or any other aspect of this collection of information, including suggestions for reducing this burden, to Washington Headquarters Services, Directorate for Information Operations and Reports, 1215 Jefferson Davis Highway, Suite 1204, Arlington, VA 22202-4302, and to the Office of Management and Budget, Paperwork Reduction Project (0704-0188), Washington, DC 20503.				
1. AGENCY USE ONLY (Leave blank)	2. REPORT DATE 15/12/94	3. REPORT TYPE AND DATES COVERED MONOGRAPH		
4. TITLE AND SUBTITLE THE CAS DISTRIBUTION PROCESS: - SHOULD THE CORPS COMMANDER HAVE DIRECT COMMAND OF USAF ASSETS?			5. FUNDING NUMBERS	
6. AUTHOR(S) MAJ GARY R. SCHAMBERG, USA, IN				
7. PERFORMING ORGANIZATION NAME(S) AND ADDRESS(ES) SCHOOL OF ADVANCED MILITARY STUDIES ATTN: ATZL-SWV FT LYNETH, KS 66027-6900 COM (913) 684-3437 AUTOVON: 552-3437			8. PERFORMING ORGANIZATION REPORT NUMBER	
9. SPONSORING/MONITORING AGENCY NAME(S) AND ADDRESS(ES)			10. SPONSORING/MONITORING AGENCY REPORT NUMBER	
11. SUPPLEMENTARY NOTES				
12a. DISTRIBUTION/AVAILABILITY STATEMENT APPROVED FOR PUBLIC RELEASE: DISTRIBUTION UNLIMITED			12b. DISTRIBUTION CODE	
13. ABSTRACT (Maximum 200 words) SEE ATTACHED.				
14. SUBJECT TERMS JFACC ATO AOC MACCS JFLCC TACAIR ASOC CAS BCE WOC			15. NUMBER OF PAGES 53	
			16. PRICE CODE	
17. SECURITY CLASSIFICATION OF REPORT UNCLASSIFIED	18. SECURITY CLASSIFICATION OF THIS PAGE UNCLASSIFIED	19. SECURITY CLASSIFICATION OF ABSTRACT UNCLASSIFIED	20. LIMITATION OF ABSTRACT UNLIMITED UNCLASSIFIED	

GENERAL INSTRUCTIONS FOR COMPLETING SF 298

The Report Documentation Page (RDP) is used in announcing and cataloging reports. It is important that this information be consistent with the rest of the report, particularly the cover and title page. Instructions for filling in each block of the form follow. It is important to **stay within the lines** to meet **optical scanning requirements**.

Block 1. Agency Use Only (Leave blank).

Block 2. Report Date. Full publication date including day, month, and year, if available (e.g. 1 Jan 88). Must cite at least the year.

Block 3. Type of Report and Dates Covered. State whether report is interim, final, etc. If applicable, enter inclusive report dates (e.g. 10 Jun 87 - 30 Jun 88).

Block 4. Title and Subtitle. A title is taken from the part of the report that provides the most meaningful and complete information. When a report is prepared in more than one volume, repeat the primary title, add volume number, and include subtitle for the specific volume. On classified documents enter the title classification in parentheses.

Block 5. Funding Numbers. To include contract and grant numbers; may include program element number(s), project number(s), task number(s), and work unit number(s). Use the following labels:

C - Contract	PR - Project
G - Grant	TA - Task
PE - Program Element	WU - Work Unit Accession No.

Block 6. Author(s). Name(s) of person(s) responsible for writing the report, performing the research, or credited with the content of the report. If editor or compiler, this should follow the name(s).

Block 7. Performing Organization Name(s) and Address(es). Self-explanatory.

Block 8. Performing Organization Report Number. Enter the unique alphanumeric report number(s) assigned by the organization performing the report.

Block 9. Sponsoring/Monitoring Agency Name(s) and Address(es). Self-explanatory.

Block 10. Sponsoring/Monitoring Agency Report Number. (If known)

Block 11. Supplementary Notes. Enter information not included elsewhere such as: Prepared in cooperation with...; Trans. of...; To be published in.... When a report is revised, include a statement whether the new report supersedes or supplements the older report.

Block 12a. Distribution/Availability Statement. Denotes public availability or limitations. Cite any availability to the public. Enter additional limitations or special markings in all capitals (e.g. NOFORN, REL, ITAR).

DOD - See DoDD 5230.24, "Distribution Statements on Technical Documents."

DOE - See authorities.

NASA - See Handbook NHB 2200.2.

NTIS - Leave blank.

Block 12b. Distribution Code.

DOD - Leave blank.

DOE - Enter DOE distribution categories from the Standard Distribution for Unclassified Scientific and Technical Reports.

NASA - Leave blank.

NTIS - Leave blank.

Block 13. Abstract. Include a brief (*Maximum 200 words*) factual summary of the most significant information contained in the report.

Block 14. Subject Terms. Keywords or phrases identifying major subjects in the report.

Block 15. Number of Pages. Enter the total number of pages.

Block 16. Price Code. Enter appropriate price code (*NTIS only*).

Blocks 17. - 19. Security Classifications. Self-explanatory. Enter U.S. Security Classification in accordance with U.S. Security Regulations (i.e., UNCLASSIFIED). If form contains classified information, stamp classification on the top and bottom of the page.

Block 20. Limitation of Abstract. This block must be completed to assign a limitation to the abstract. Enter either UL (unlimited) or SAR (same as report). An entry in this block is necessary if the abstract is to be limited. If blank, the abstract is assumed to be unlimited.

SCHOOL OF ADVANCED MILITARY STUDIES

MONOGRAPH APPROVAL

Major Gary R. Schamburg

Title of Monograph: The CAS Distribution Process: Should the
Corps Commander Have Direct Command of
USAF Assets?

Approved by:

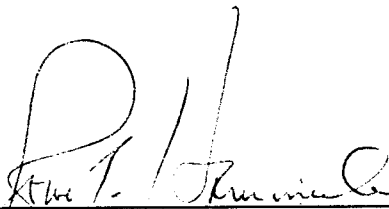

LTC Robert Hammerle

Monograph Director

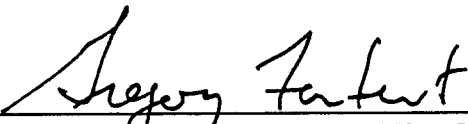

COL Gregory Fontenot, MA, MMAS

Director, School of
Advanced Military
Studies

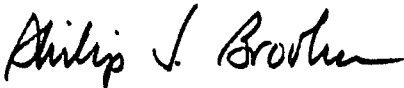

Philip J. Brookes, Ph.D.

Director, Graduate
Degree Program

Accepted this 17th day of December 1994

ABSTRACT

This monograph examines the primary question: Should the CAS distribution process as practiced under the ATO system be modified to task organize distributed USAF assets into the corps organization for a definite period of time or task? It proposes a doctrinal shift in the use of airpower to support corps operations. This monograph divides into sections that explain the current and a proposed CAS distribution systems. **Section One** defines the Air Force and Army doctrine for apportioning air assets, and explains the doctrinal CAS distribution processes for corps-level operations. **Section Two** evaluates the current CAS distribution system. It begins with an analysis of CAS during the Gulf War, and then evaluates the CAS system with three of the Army doctrinal tenets as criteria: *agility, synchronization, and initiative*. The analysis concludes with a review of the Marine Corps TACAIR philosophy and organization. **Section Three** proposes a doctrinal modification that task organizes Air Force units directly to the corps. **Section Four** analyzes this modified system based on Air Force, Army and Marine doctrine. This section uses the same factors from Section Two to appraise the modified CAS system. Finally, the **Conclusion** resolves the monograph question.

Accession For	
NTIS CRA&I	<input checked="" type="checkbox"/>
DTIC TAB	<input type="checkbox"/>
Unannounced	<input type="checkbox"/>
Justification	
By	
Distribution /	
Availability Codes	
Dist	Avail and/or Special
A-1	

TABLE OF CONTENTS

	<i>Page</i>
Introduction	1
Section One, <i>Defining Air Force and Army Doctrine</i>	4
Section Two, <i>Evaluating the CAS distribution system</i>	14
Section Three, <i>Proposing a Modified CAS System</i>	25
Section Four, <i>Evaluating the Modified CAS System</i>	32
Conclusion	40
Endnotes	44
Bibliography	51

INTRODUCTION

Defining the Problem

This monograph explores a proposed doctrinal shift in the use of airpower to support corps operations. In an era of shrinking ground combat forces, the corps commander strives to maximize the combat force brought to bear on the battlefield. The organic combat forces he applies for victory ensue from armor, infantry, artillery, and Army aviation units. One additional element, that becomes increasingly important for the corps commander, is his distributed air assets. Once the theater air component achieves air superiority, the army corps uses the air tasking order (ATO) process to receive these tactical air (TACAIR) assets. This monograph analyzes efficiency of the current ATO process in providing close air support (CAS) in support of corps tactical operations.

Significance. According to the latest news accounts, the Army structure will continue to decrease in the next several years. These reductions include units, personnel, and equipment. Throughout this period of reduction, the Army must still be ready to fight and win major regional conflicts (MRC) as one partner in the joint team. These reductions may affect the number of forces available to the corps commander to achieve success on the battlefield. This situation becomes significant with a National Security Strategy that requires near simultaneous victory in two MRCs. With potential reductions in his ground forces, the corps

commander will become increasingly reliant on the USAF to shape his tactical fight.

Monograph Questions. This future situation of reduced ground combat forces begs a study of the doctrinal application of CAS distribution to the corps. The corps commander employs his forces to achieve the greatest combat energy and win battles in future conflicts. This monograph examines the primary question: Should the CAS distribution process as practiced under the ATO system be modified to task organize distributed USAF assets into the corps organization for a definite period of time or task?

Monograph Procedure. This monograph pursues a unique path to answer the primary question. It divides into sections that explain the current and modified CAS distribution systems. After each explanation, the subsequent section evaluates the system based on current Air Force, Army and Marine doctrine.

Section One defines the Air Force and Army doctrine for apportioning air assets. This section explains the doctrinal processes currently employing for corps-level operations.

Section Two evaluates the current CAS distribution system. It begins with an analysis of CAS during the Gulf War, and then evaluates the CAS system with three of the Army doctrinal tenets as criteria: *agility, synchronization, and initiative*. Finally, both the Marine Corps philosophy and organization are used to

analyze TACAIR.

Section Three proposes a doctrinal modification to the ATO process for apportioning CAS assets to the corps. This modified system is based on task organizing Air Force units directly to the corps.

Section Four analyzes this modified system based on Air Force, Army and Marine doctrine. This section uses the same factors from **Section Two** to appraise the modified CAS system.

The **Conclusion**, which resolves the monograph's question, follows **Section Four**.

SECTION ONE

Defining Air Force and Army Doctrine

Introduction. How the corps commander fights his distributed CAS assets results from applying USAF and Army doctrine. Reviewing these doctrines clarifies the parameters within which the corps works to employ CAS assets. USAF doctrine defines the theater air asset distribution system or CAS apportionment process. Both doctrines combine to create the corps connection into the CAS system. Air Force doctrine mainly concerns the ATO process in which the joint forces air component commander (JFACC) determines the apportionment of his air assets. Each doctrine contributes to the manner in which the corps receives and employs its CAS assets. This section first clarifies the overriding USAF doctrine that impacts on the theater and ultimately on corps operations. It next explains the theater air asset distribution process as exercised in the air tasking order (ATO). Finally, this section portrays the corps connection into the CAS process and the elements within the corps that execute air operations.

USAF Doctrine. The US Air Force tenet, *Centralized Control - Decentralized Execution*, guides Air Force operations in the theater fight. This tenet takes shape in three parts. First, centralized control results in the Air Force stressing the establishment of a theater Air Force commander or JFACC. Secondly, this tenet ensures the JFACC produces a theater air concept of

operations that achieves air superiority and supports the theater commander's campaign plan. The tenet's final element is the ATO.

Centralized Control - Decentralized Execution is the primary philosophy that influences USAF doctrine. Historically, ground commanders employed the USAF under the premise that aircraft were simply extensions of field artillery. Not until late in World War II did ground and air commanders in the European theater reach agreement on how to best use theater air. This argument led to the cornerstone of Air Force warfighting, that centralized control made the most effective use of airpower. From this concept evolved the three elements of centralized control.¹

The establishment of a theater air commander represents the first means of "centralized control." This commander, or JFACC, embodies the sole responsible warfighter for all air assets within theater. These air assets include the Air Force units in theater, Navy air units not responsible for fleet security, and USMC air units not involved in tactical operations for the Marine commander. He plans and coordinates the air concept of operations that supports campaign planning conducted under the direction of the theater commander or joint forces commander (JFC).² The JFACC epitomizes the concept of central control because he oversees these air assets and the planning of their employment.

The air concept of operations is the second element of centralized control in the theater. This concept achieves two tasks based on USAF doctrine. First, it directs operations to achieve air superiority. Second, it compliments achieving

the JFC's campaign goals. Analyzing these tasks reveals further aspects of theater centralized control.

USAF doctrine states that the primary operation of the theater air force is to gain control of the aerospace environment. Air superiority is the endstate. When air superiority is attained, air assets can operate in the theater where needed and accomplish their mission with acceptable friendly losses. Such air control does not imply that an enemy threat will not exist, only that losses sustained are consistent with target values. By achieving air superiority, the theater air force provides the JFC a highly lethal capability for influencing the outcome of theater operations.³ The USAF concludes that the most effective and efficient method to achieve air superiority occurs through a primary plan that controls operations at the theater level.

Supporting the theater commander's operational plan is the second task of the air concept of operations. Air Force doctrine ensures that air assets are orchestrated in the most productive and advantageous manner to accomplish the JFC's campaign goals. This philosophy restrains the employment of air assets from operations that fail to realize the theater commander's endstate. Additionally, this philosophy guarantees unity of effort among theater air units.⁴ The USAF concludes that supporting the CINC's plan is best accomplished by adhering to the air concept of operations.

The third means of theater "centralized control" is through the ATO process. The ATO is the means the JFACC uses to control theater air assets, and his

primary method for executing air operations. It is through the ATO, that the corps receives its CAS allocations. Development of the ATO determines the amount of air assets distributed to the corps, and thus requires careful examination.

The ATO. This theater process shapes how the JFACC distributes his assets according to the air operations plan. The ATO also ensures theater air assets receive a balanced distribution in accordance with this plan. The ATO is the theater tool that the JFACC uses to transmit his decision on the amount of CAS support the corps commander obtains to fight his battle. Figure 1 illustrates the ATO process and identifies the numerous staff elements that must coordinate to bring CAS to the corps commander.⁵

The ATO process begins when the JFC publishes his campaign plan. In Figure 1, the campaign guidance results from the JFC's campaign plan, which represents the operational plan for the theater. In his planning, the JFC gives "broad" apportionment guidance to all components. This guidance reflects the JFC's decisions on main effort and supporting efforts. The joint forces land component commander (JFLCC) and the JFACC prepare their plans based on the JFC's campaign guidance. As the JFACC develops his air concept of operations, the JFLCC also plans operations for the forces under his command, which filters down through the corps and ultimately to the divisions.⁶

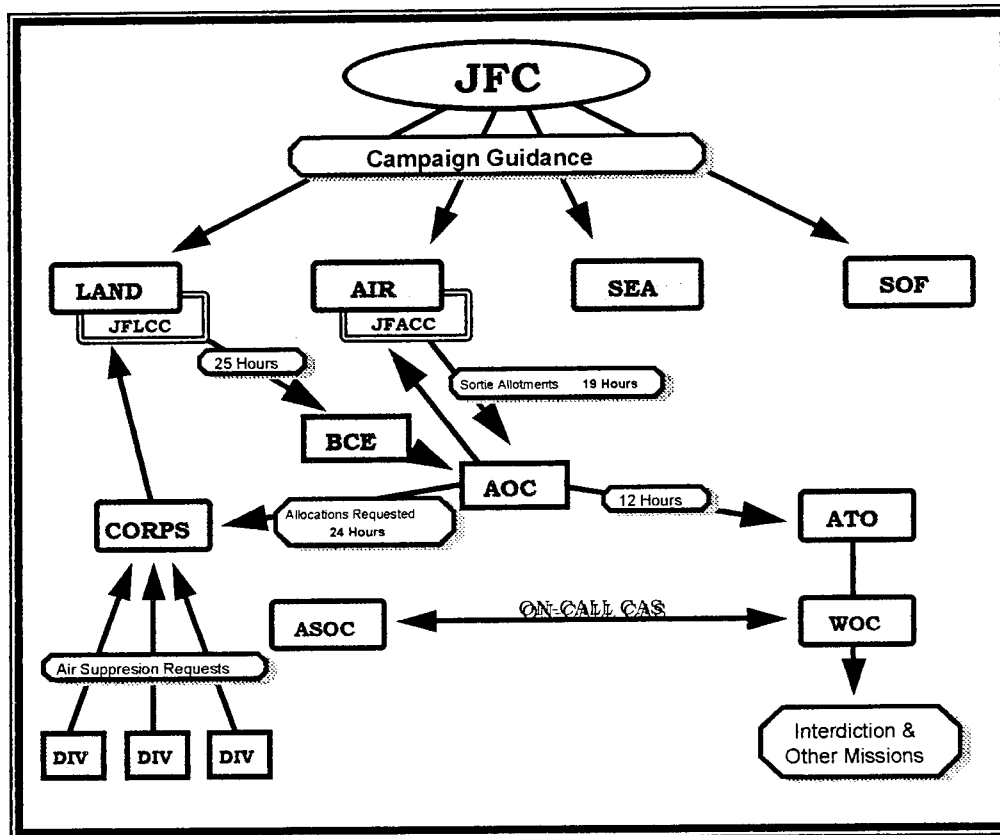

Figure 1
The ATO Process and Coordinating Staffs

The ATO process works on a 72-hour schedule with 48-hours for mission planning and 24-hours for execution. Divisions submit their CAS requests to the corps during the 48-hour planning time. The corps staff adds its CAS requests, collates all requests, and submits them to the JFLCC. The JFLCC staff prioritizes and submits during the first planning day all land component CAS requests to the battlefield coordination element (BCE), who is their liaison element at the JFACC's theater air operations center (AOC). (A typical request could be 20 CAS sorties for II(US)corps between 0600-1000 against armor targets in II(US)corps

zone.) The BCE coordinates the JFLCC requests with the AOC. From the JFLCC requests and the air concept of operations, the AOC under the direction of the JFACC develops the air employment plan and sends a copy through the BCE to the JFLCC. The air employment plan provides the land component with an idea of what sorties were filled, which sorties were not filled, and what unused sorties are available. This message is transmitted from the JFLCC staff down to the corps ASOC. This message represents the first time the corps receives feedback on whether or not its requests have been filled.

During the second planning day, the AOC sends a copy of the air employment plan to the JFACC for his approval. The JFACC makes "adjustments" as necessary, approves the plan, and sends the "final" version to the AOC. The AOC again provides a copy to the JFLCC staff, who forward the updated list to the corps ASOC. This copy is the second time the corps is provided feedback on forecasted air support.

12-hours prior to the execution day, the AOC publishes the approved ATO. At this time, the wing operations center (WOC) receives their first detailed instructions, and assigns units to attack the identified target. These units continue to monitor the mission and provide the AOC, through their respective WOC, any updates on their status. The AOC in turn provides their status to the JFLCC staff, who continue to update the corps ASOC.⁷ This is the third time the corps finds out the status of its requests.

Overall, the ATO process provides the corps three updates on CAS requests.

The first occurs after the AOC develops the air employment plan during the first day of the ATO planning cycle. The second is provided when the JFACC approves the air employment plan during the second day of the 48-hour planning cycle. The third update happens during the execution day of the ATO cycle. Additional updates begin once the flying unit begins preparing for the mission and end when the mission is completed.

Corps Level Doctrine. Army and Air Force doctrine stress the requirement for coordination between the land and air components. Both doctrines, additionally, specify the ASOC as the component that links the corps into the CAS and ATO processes. The ASOC is under the operational control of the AOC, and co-locates with the corps Main Command Post. The ASOC is composed entirely of Air Force personnel.⁸ Figure 2 illustrates the linkage between the AOC, the component staffs, the BCE, the corps, and the ASOC.⁹

The ASOC serves two functions -- advice and direction.

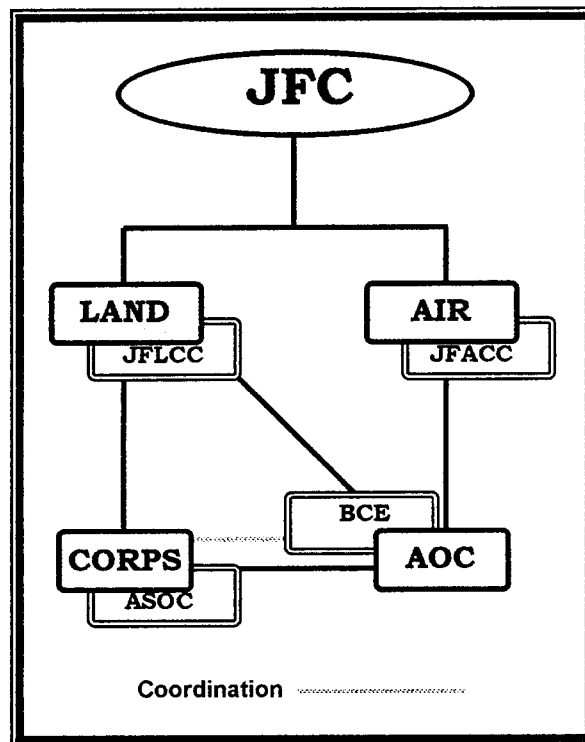

Figure 2
ASOC Linkage

First, it advises the corps commander on the capabilities and limitations of TACAIR to support corps operations. Coordinating and executing TACAIR support through the control of CAS and tactical air reconnaissance (TAR) is its second function. These functions insure synchronization by applying combat power, optimizing support, and preventing interference in the corps battle.¹⁰

Figure 3 depicts the relationship of the ASOC to the corps staff.¹¹

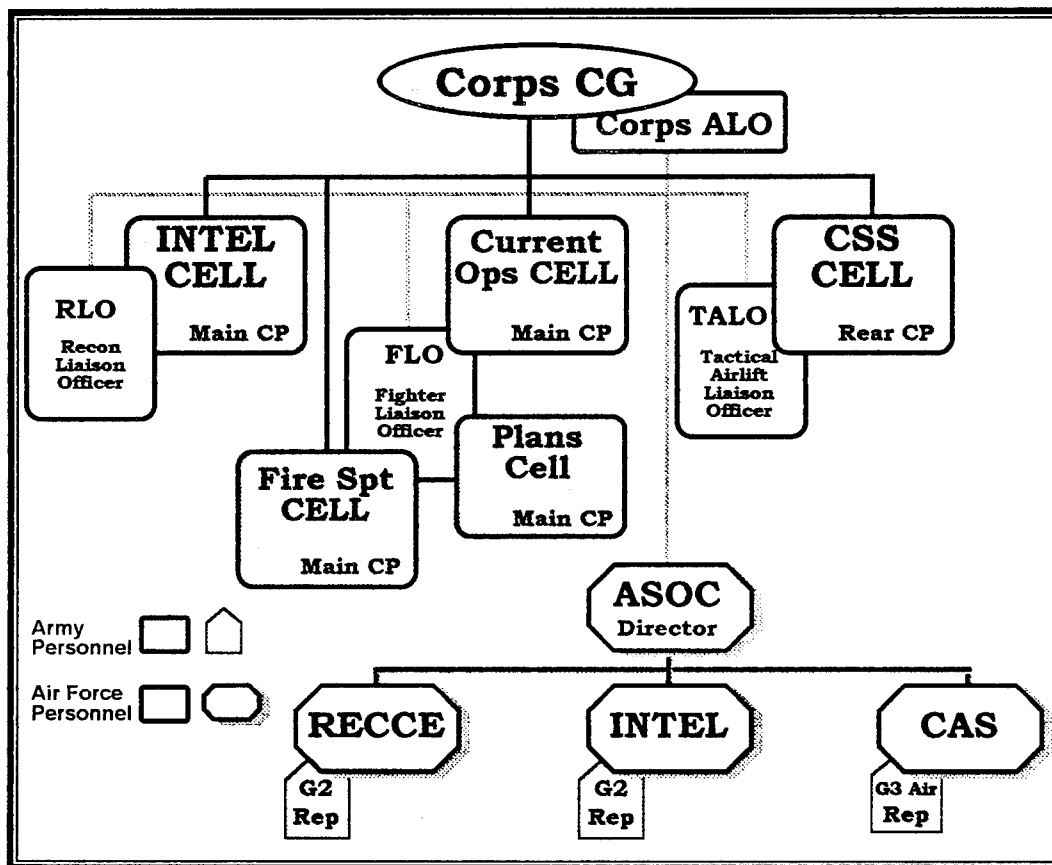

Figure 3
ASOC Relationships

The elements responsible for planning and coordinating CAS sorties are the air liaison officer (ALO), the fighter liaison officer (FLO), and the CAS cell of the ASOC. The principle Air Force liaison to the corps is the ALO, who heads the ASOC. The principle Air Force liaison to the corps is the ALO, who heads the ASOC. The corps G3 coordinates with the ALO when planning CAS and TAR sorties. The corps ALO assists in preparing the employment of forecasted air assets against planned targets.

The fighter liaison officer (FLO) operates in the Main CP. He works with the current operations, fire support and plans cells. His primary function is providing advice on tactical air capabilities and assisting with the preparation of preplanned fighter support requests. Additionally, he coordinates corps support for air operations to include artillery SEAD and army aviation support.

The CAS section in the ASOC plans, coordinates, and controls all corps CAS operations. It can be thought of as the hub of CAS activities within the corps. This section is responsible for requesting and controlling air assets to support corps tactical operations. Here decisions are made that match division requests and the commander's priorities with air asset resources. This section must understand the commander's intent and act to fulfill the necessary requirements.¹²

Summary. This section examined the current USAF and Army doctrine that influence the reception and use of theater air assets in support of corps operations. This examination began with a review of keystone USAF doctrine and then, reviewed the CAS distribution system under the current ATO system. It

further explains the corps' connection into the ATO process and the elements that implement CAS operations. The foundation laid out in this section will be used in the next section to evaluate the existing CAS distribution system.

SECTION TWO

Evaluating the CAS distribution system

Introduction. Lieutenant General John Cushman, a former corps commander, believes that the Air Force and Army fail to harmonize their operations. In his pamphlet, ***Thoughts for Joint Commanders***, LTG Cushman asserts that problems spring from differences between air and land doctrine. He points out that the CAS distribution system is never satisfactory in "shaping the battlefield" for land commanders.¹ This section analyzes the CAS system in a two tiered approach: first, it will discuss the reasons for disharmony in the CAS system, and then it will examine an alternative approach to air asset distribution.

First, as stated, differences in doctrine are the primary cause of the disconnect. Lessons learned from DESERT STORM reinforce the disunity mentioned in LTG Cushman's assessment. While the JFACC was able to apply the central tenet of Air Force doctrine, the Army corps commanders were frustrated in applying their doctrine because of problems with the ATO system and target selection.² Because corps commanders fight under the influence of specific doctrinal tenets, evaluating the CAS system with these tenets further reveals the disparity between Army and Air Force doctrine.

Secondly, this section examines the merits of Marine Corps doctrine as an alternative air distribution system. Unlike the Army commanders' experience, the Marine senior commander did not encounter any of this TACAIR frustration

during the Gulf War.³ His contentment stems from the unique USMC organization and command philosophy as applied to air distribution.

The weaknesses identified in the current system by this two step approach develop the foundations for the modified system proposed in Section Three. This new system will capitalize on the strengths of the existing system while correcting its shortcomings.

The Gulf War Experience. Operation Desert Storm offers excellent examples for analyzing the wartime use of the current CAS system. The importance of overwhelming airpower in the conduct of ground operations was clearly demonstrated in this conflict. The combination of an abundance of air assets, little air opposition, and the choice of when to attack (surprise) all contributed to creating the optimum environment for air operations. A case in point highlights these ideal conditions: the JFACC was never required to reallocate air assets from one component command to alleviate a shortfall in another area or command.⁴ Nonetheless, a review of the Gulf War's lessons learned indicate the CAS system frustrated Army corps commanders. Problems in target nominations, apportionment, prioritization, and diversions continuously emerged. These shortcomings highlight the disconnect between the Air Force's desire to efficiently manage their forces and the Army's quest for agility, synchronization, and initiative.

The CAS distribution system employed during the conflict achieved success

in three areas. First, the air component executed operations along the lines of the theater commander's campaign plan. This execution insured the committed corps received air assets which dovetailed with the JFC's priorities.⁵ Second, the JFACC, Lieutenant General Chuck Horner, effectively controlled all theater air assets, excluding the Navy units responsible for fleet defense and USMC units responsible for tactical operations. The JFACC's centralized control coherently orchestrated air support for both Army corps during the ground fight. He struck a delicate balance. He insured the ATO met the JFC's campaign guidance: maintain air superiority, strike strategic targets, and set the conditions for the ground offensive.⁶ Third, the JFACC fed PUSH CAS sorties to the land elements. These sorties allowed the corps commanders to add air strikes into their tactical fight.⁷ These harmonious facets of the Gulf War's air distribution system reveal general agreement between the two doctrines.

However, discord in three other aspects of the Gulf War's CAS system highlight the disconnect between the doctrines. First, the planning and coordination necessary to produce the ATO took too long to develop and publish. This delay caused both corps problems in confirming if essential pre-planned targets were being attacked.⁸ Second, on many occasions, the ATO changed prior to execution. These last minute alterations, again, caused the corps to remain uncertain if apportioned CAS assets would strike critical pre-planned targets at the appropriate time. A key component that is necessary to orchestrate air into the tactical battle.⁹ Third, the corps commanders expressed concern over target

selection. The JFC required fifty percent destruction of Iraqi tanks and artillery prior to the ground offensive. The JFACC understood this requirement, but concentrated on armor and began "plinking" these single tanks with theater assets. The corps commanders disagreed with this priority. They feared artillery most, and believed their armor and helicopter forces could easily destroy the Iraqi tanks.¹⁰ These three problems resulted from conflicts in doctrine. A further analysis of the CAS system with Army doctrine reveals why this friction developed.

Army Doctrine Analysis. The Army tenets contained in the 1993 edition of FM 100-5 describe the viewpoint that corps commanders follow to generate and apply maximum force for success on the battlefield. The tenets of *Agility*, *Synchronization*, and *Initiative* color the way the corps commander fights. The commander employs his units according to these tenets to win on the battlefield. Accordingly, the corps commander attempts to employ his CAS assets in the same manner as infantry, armor, artillery, or attack aviation units.¹¹ Evaluating the current CAS distribution system against these tenets highlights the inability of the system to support current Army warfighting doctrine.

Agility

Agility is the ability of friendly forces to react faster than the enemy and is a prerequisite for seizing and holding the initiative. This tenets suggests

"quickness." The corps must be able to concentrate forces faster than the enemy; and rapidly and successively mass its maneuver, fire support, and apportioned air assets.¹² Agility presents another dilemma for the Corps .

The ATO process fails to allow timely reactions to enemy actions. The agility of the corps suffers because the CAS system places four bureaucracies between the commander and his TACAIR: the JFLCC staff, the BCE, the AOC and the WOC. When the enemy acts to overcome friendly forces, the timing of the air responses and the corps reaction might suffer. The corps must approximate enemy tactical actions 72-hours in advance using the CAS request process. Because the enemy maneuvers according to his own schedule, not the corps commander's, the airstrike could result in an unsuccessful attack. While changes to request can be coordinated up to 24-hours prior to attack, the process must still pass through four staffs with each possessing the ability to alter timing.¹³ These decisions can adversely impact on the corps fight. As the corps requests additional assets through the CAS system, time lengthens and causes the corps commander to react in an untimely manner.

Synchronization

Synchronization is arranging activities in time and space to mass at the decisive point. Units achieve synchronization by integrating the activities of their elements to achieve coordinated activity. This effective coordination maximizes all of the corps' resources to produce the greatest contribution toward battlefield

success. The corps achieves synchronization through effective and efficient coordination between various units and activities participating in an engagement.¹⁴

Effective coordination for synchronization is difficult with the existing CAS system. The Air Force views the battle as controlling time, while the Army sees the battle as controlling events. For the Air Force, time determines when aircraft attack targets. Since throughout the theater many targets require air attack, the Air Force allocates air assets for a definite time against definite targets. The JFACC and AOC balance theater priorities and use the ATO to schedule the time periods for aircraft.¹⁵ Their ability to balance assets according to a time sequence fundamentally determines when the corps commander receives his TACAIR support. His control of the air assets is for a particular time based on that day's air employment plan. This scheduling causes friction as the corps commander attempts to synchronize his forces for battle.

The corps commander integrates the activities of his combat units to win tactical engagements. Each engagement represents an event in which his infantry, attack helicopters, armor and artillery units fight the enemy. As their activities ebb and flow during the engagement, the commander coordinates their efforts to achieve success. This coordination, or synchronization, occurs as he shifts his forces to take advantage of enemy weaknesses.¹⁶ The corps commander accomplishes this synchronization through the command relationships established with his subordinate units. These ground combat units remain under his

command throughout the engagement or event. Unlike these Army units, the TACAIR asset, scheduled through the ATO process, may not arrive as events reach their peak. When these air assets fail to arrive, effective coordination is lost which produces ineffective synchronization.

Initiative

Initiative sets or changes the terms of battle by action and implies an offensive spirit in the conduct of all operations. Primarily, initiative represents the relationship between the corps commander's intent and the actions of subordinate units, leaders and soldiers. When their actions follow the commander's guidance, they take actions that insure unity of effort. Basically, proper initiative guarantees that units acting independently because of attrition or faulty communications continue to act to defeat the enemy.¹⁷

Because the CAS system fails to provide the corps commander's intent to the flying unit, pilots lack an ability to act on their initiative and influence the corps' effort. The ATO message to the flying unit does not publish the corps commander's intent or the purpose of the mission.¹⁸ The pilot flying the airstrike knows target location, attack altitude, type weapons, and the procedures for communicating with the forward air controller (FAC); but the reason and purpose for their actions remain unknown. The reason for attacking either the primary or secondary target is lacking. Because they know only these targets, if the targets are not in the area of the FAC, they return to base without employing their

munitions. If they knew the corps commander's intent was to attack a specific enemy formation when it moved from an assembly area, they could delay in the area or arrive for their strike when the enemy began movement. Using their initiative in such a manner assists the corps' tactical fight. Unless the pilot knows the corps commander's intent, his actions in such situations produce no offensive result for the corps commander.

The problems with the current CAS system, identified in this Army doctrine analysis, result from the Air Forces' concern for control and efficiency of aircraft usage. This conflict between Air Force and Army doctrine produces frustration for the corps commander. As evidenced by the Gulf War and the above analysis, the corps commander experiences difficulty in concentrating his forces for the tactical battle. The Marine Corps suffers under no such problems. An analysis of the Marine CAS system reveals why this friction is lacking.

Marine Doctrine Analysis. USMC doctrine determines how the Marines employ their air units to support tactical ground operations. Marine doctrine emphasizes homogeneous operations that maximize their forces impact on the battlefield.¹⁹ To achieve these homogeneous operations, Marine doctrine developed a unique organization and a unifying philosophy, typified by the Marine Air Command and Control System (MACCS). While MACCS is the equivalent of the Air Force and Army's CAS system, it significantly differs with the latter in its organization and command philosophy. MACCS plays a

prominent role in the Marine Air-Ground Task Force (MAGTF), which is similar to the Army corps, but dissimilar in its organization for tactical air support.²⁰ Additionally, MACCS incorporates the Marine doctrinal philosophy that stresses initiative, which is lacking in the CAS system. These two elements furnish additional criteria to analyze the CAS system.

The MAGTF tactical air support organization differs from Army corps in the responsibilities of these assets. MACCS is the reason. Under MACCS, Marine aviation is task organized to the MAGTF as a Marine Aviation Wing (MAW). The MACCS process causes the MAW to respond directly to tactical planning conducted by the MAGTF staff. The MAW, additionally, executes these missions under the control of the Marine Air Control Group (MACG). The MACG plans, coordinates and conducts all MAGTF air operations in joint and combined operations. Basically, the MAW and MACG are responsible to the MAGTF commander, and work for him under MACCS.²¹ This situation is different in the Army corps. There, the ALO and ASOC work for corps commander but are responsible to the AOC, and the flying unit commanders work for and are responsible through the AOC to the JFACC.

The MACCS presents another difference between Marine doctrine and the CAS system. Marine doctrine emphasizes initiative in its Philosophy of Command:

in order to generate the tempo of operations we desire and to best cope with the uncertainty, disorder, and fluidity of combat, command must be decentralized. That is, subordinate commanders must make decisions on

their own initiative, based on their understanding of their senior's intent, rather than passing information up the chain of command and waiting for the decision to be passed down.²²

Additionally, their doctrine highlights initiative when shaping the battle:

The first requirement is to establish our intent; what we want to accomplish and how. Without a clearly identified intent, the necessary unity of effort is inconceivable.²³

This command philosophy that stresses initiative, particularly on the battlefield, insures the MACCS process conducts operations homogeneously to maximize the MAGTF's combat power. The USAF CAS system fails to achieve this unity of effort. As analyzed above in the Army tenets, the ATO fails to publish the corps commander's intent necessary for pilots to use their initiative and act in unity with corps operations. Any pilot decision based on initiative must be passed up the air component chain of command, and then down through the land component chain.

MACCS significantly contrasts with the CAS system. Because the Marines stress unity of effort (homogeneous operations) to maximize their forces on the battlefield, their doctrine produced a different organization and command philosophy. These two differences allows MACCS to harmonize MAGTF operations, which is unlike the disharmony within the CAS system.

Summary. The CAS distribution system does not adequately maximize combat power in support of corps operations. The Gulf War demonstrated problems with ATO procedural delays, ATO alterations, and target selection.

Both corps encountered obstacles with the current CAS system that affected their operations. The analysis of this system under Army doctrine revealed further problems with command, coordination, and organization that detract from the corps' ability to concentrate its combat power. Primarily, these problems occur because of discord between Air Force doctrine, which is based on time to ensure efficient aircraft employment, and Army doctrine, which is founded on event driven activities. Marine Corps doctrine exposed similar problems with the USAF CAS distribution system. These problems were alleviated in the USMC CAS system by a unique organization and command philosophy that emphasizes homogeneous operations. The next section proposes remedies to these problems that work within the CAS system to allow the corps commander to maximize the combat power of his forces on the battlefield.

SECTION THREE

Proposing a Modified CAS System

Introduction. This section proposes remedies to synchronization problems identified in Section Two. These solutions permit the corps to maximize its efforts on the battlefield. This solution occurs once air superiority is achieved, and minimally modifies the current CAS System. The first alteration modifies the CAS distribution system by distributing air assets directly to the corps commander. This modification still allocates air assets based on the ATO process, but air units would be under the direct command of the corps commander for definite periods of time. The second modification alters the corps ASOC by increasing the liaison effort between the supporting air unit and the corps. Of particular note, these minor cures occur within the current CAS distribution system, and propose no overhaul of the system. More importantly, this proposal solves the dilemma of maximizing corps combat power on the battlefield.

The Modified Distribution Process. The modifications proposed retain many of the features of current ATO procedures. The ATO still ensures balanced theater air asset distribution in accordance with the JFC's campaign plan, because the JFACC and JFLCC continue to coordinate air priorities. The JFACC through the AOC still provides guidance to air assets for air superiority missions and

operational and strategic targeting missions through the ATO. The modification concerns the distribution of air units directly to the corps. Figure 4 illustrates the modified CAS process.¹

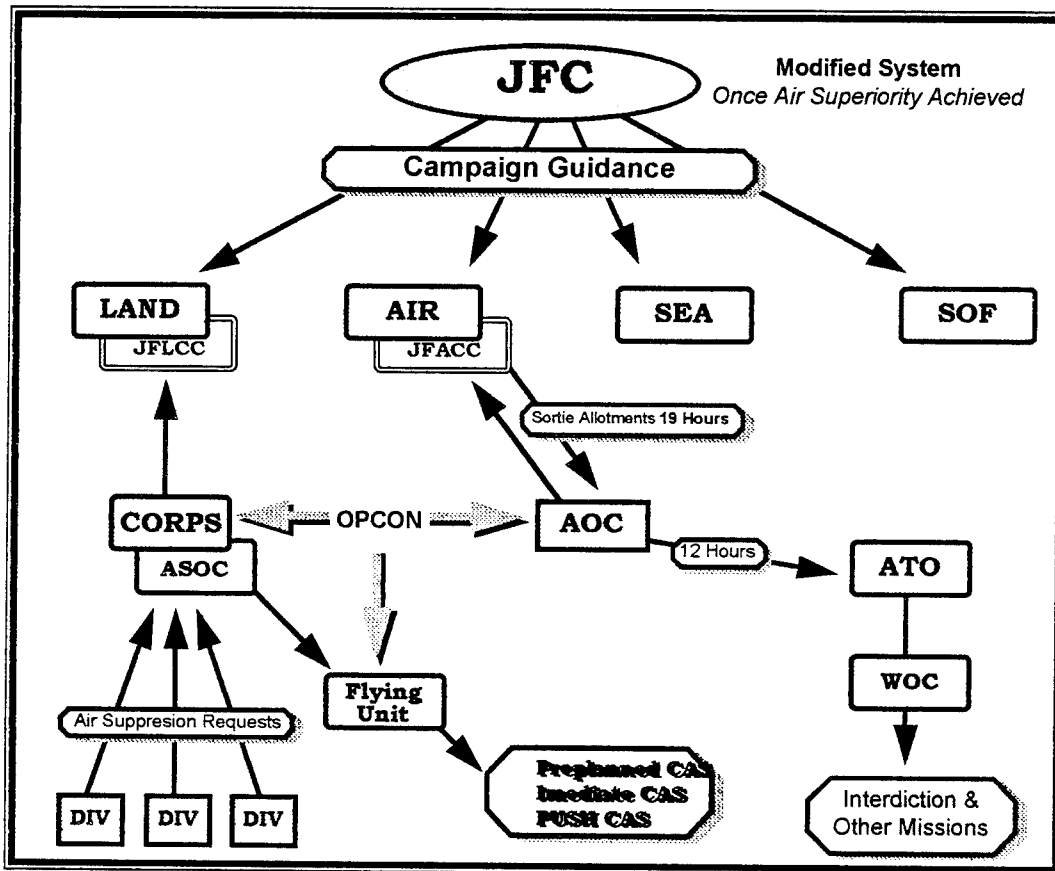

Figure 4
Modified ATO Process and Associated Staffs

The process starts with the theater commander's campaign plan. Similar to the current system, the JFC provides broad air allocation guidance that reflect the JFC's decisions on main effort and supporting efforts. The JFLCC and JFACC still prepare their plans based on the JFC's guidance, and recommend air asset

apportionment to the JFC. The JFC continues to approve the apportionment recommendation.

The modification occurs during the 48-hour planning period within the ATO's 72-hour window. Divisions continue to submit their CAS requests to the corps, who continue to review and collate these requests for submission to the JFLCC. The similarities end once the JFLCC receives the corps request. The JFLCC and JFACC determine the number and type of air assets necessary to support land operations based on the JFC's priorities and the Corps' CAS requests. Once a balance has been struck, the JFACC sends the agreed upon allocation to the AOC. The AOC then develops an air employment plan.

This air employment plan differs only slightly from the current ATO process. The difference focuses on task organization. Under the current system, the AOC plans sorties for maintaining air superiority, attacking operational and strategic targets, and supporting land component operations. Under the new system, the AOC develops sorties for maintaining air superiority and targeting operational and strategic objectives, but task organizes air units to support land component operations. Once the air employment plan determines this task organization, which is approved by the JFACC and the JFLCC, the results are forwarded to the corps. Because the JFLCC has already set his priorities when previously coordinating with the JFACC, the task organization furnishes air units directly to the corps.

The AOC's air employment plan should apportion air units to the corps in an

OPCON command relationship. These relationships would allow the corps commander to assign tasks, designate strike objectives, and provide for mission accomplishment. Three functions of these relationships insure the necessary minimum essential control.² First, the corps could not interfere in administrative and logistical support that is directly related to traditional Air Force functions. The JFACC would still provide administrative and logistical support, because these assets would remain under his command. Second, the JFACC would provide the flying unit for a definite time period or event. This requirement permits the JFACC with the coordination of the JFLCC to re-prioritize air units as the operational situation changes. Lastly, the corps could not further subassign air units. The OPCON command relationship allows the JFACC to return the air unit quickly to his control if the enemy threatens to negate air superiority.

The Modified CAS System. The ASOC remains the component that links the Air Force units with the corps. The ASOC continues under the operational control of the AOC, collocates with the corps Main CP, and is composed of Air Force personnel. Figure 5 illustrates the "new" linkage between the AOC, the BCE, the theater staffs, the corps, and the ASOC.³

The ASOC still executes the two functions of advise and control between air assets and the corps. In its advise capacity, the ASOC still appraises the corps Commander on the capabilities and limitations of TACAIR. Only the second function receives slight modification. To insure synchronization during the corps

battle, the ASOC now provides a direct link between the air unit's staff and the corps staff. Under this modified CAS system, the ASOC includes the liaison officers from the air unit. Additionally, the ASOC contains corps staff officers to act as liaison to the air unit. Figure 6 depicts the relationships of the ASOC, the corps staff, the "new" liaison officers and the flying unit.⁴

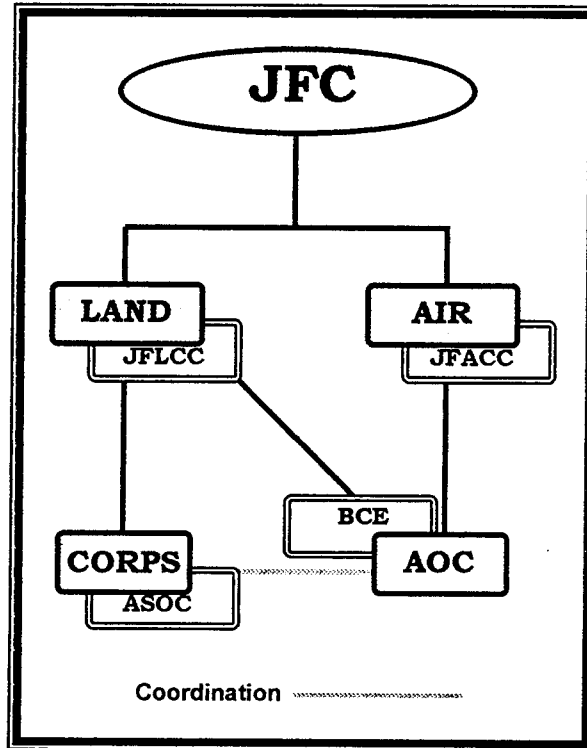

Figure 5
ASOC Linkage

With the proposed modifications, the ALO, FLO, and CAS cell retain responsibility for planning and coordinating CAS sorties. The principle Air Force liaison to the corps remains the ALO, who continues to prepare the employment of forecasted air assets against planned targets.

The only difference in the modified system concerns the liaison responsibility between the corps staff and ASOC. The flying unit's liaison personnel are now required to coordinate with the corps staff in the Main CP. They must become particularly familiar with the procedures, requirements and techniques of the Current Ops, Fire Support, Intel, and Plans Cells. Additionally, these liaison

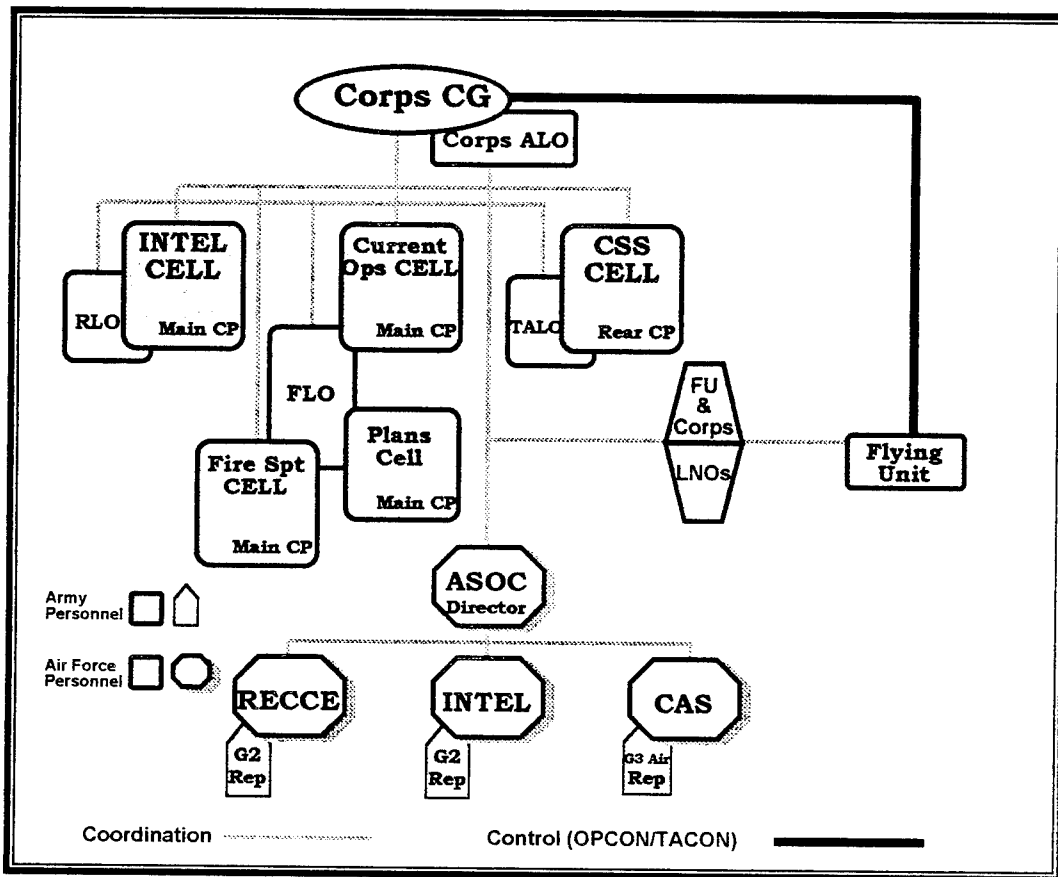

Figure 6
ASOC Relationships

officers should become proficient in the responsibilities of attached Air Force personnel such as the FLO and RLO. The same is true for the corps liaison personnel. Because they represent the corps' connection with the flying unit, their liaison obligations tie the corps tactical plan into the flying unit's execution. If these personnel fail to grasp the concept of operations and intent, the flying unit's airstrike will miscarry.

Summary. This section attempts to solve the battlefield maximization

problems identified in Section Two by permitting the corps a more direct link with the supporting TACAIR assets. These modifications occur after air superiority is achieved, and remain within the procedures of the current system. The proposal adjusts the CAS distribution system to directly distribute air assets to the corps commander. This proposal builds on the ATO process, and apportions air units either OPCON directly to the corps. Further, this proposal modifies the corps ASOC by increasing the liaison responsibility between the corps and the supporting air unit. While these minor cures function within the current system, further analysis under USAF and Army doctrine will determine if this proposal truly achieves the maximization of corps combat power. Section Four conducts that evaluation.

SECTION FOUR

Evaluating the Modified CAS System

Introduction. An evaluation of the modified CAS distribution system determines whether this "new" system adheres to USAF, Army and Marine doctrine. While analysis of the current CAS system revealed several flaws, examining the modified system with the same criteria could expose fresh difficulties. This section conducts this type of examination. It offers a doctrinal analysis of the proposed CAS system using the Air Force's primary tenet - *Centralized Control, Decentralized Execution*. The section further analyzes the modifications with the Army's doctrinal tenets. Finally, Section Four analyzes the "new" system with USMC doctrine. These examinations follow the procedures laid out in Section Two. This analysis will determine if the modified system continues to hinder or facilitate the corps commander's attempts to maximize combat force for his tactical battle.

Air Force Doctrine Analysis. As explained in Section One, the central tenet of US Air Force doctrine is *Centralized Control - Decentralized Execution*. This tenet guides Air Force operations in the theater fight, and takes shape in three ways. Again, theater control is established with the appointment of a overall air commander (JFACC), the publication of a theater air operations plan, and a process to control air units through ATO procedures. These characteristics

represent the yardstick for evaluating the proposed system.

The modified CAS system retains the theater air commander for "centralized control." The JFACC remains responsible for all air assets within the theater. He still supports the theater commander's campaign plan by planning and coordinating the air campaign. The only adjustment to his responsibilities concerns his direct control over the flying units supporting the land component's committed corps. Where previously the JFACC organized and integrated the operations of these air units into his air campaign, now these air assets receive guidance from the corps commander.

Does this adjustment run contrary to USAF doctrine? The Air Force would argue against this approach based on their historical experience. Yet, the answer is no for two reasons. First, the Air Force continues to be well represented on the corps staff. The ALO, along with his ASOC staff, retains responsibility for planning and coordinating CAS sorties within the corps. The second reason follows from the corps' potential to be designated a Joint Task Force (JTF) headquarters. In such a situation, doctrine names the corps commander as the JFC, while the corps ALO assumes duties as the JFACC.¹ If the corps can execute these responsibilities in a "small" theater, then the corps should be able to handle these responsibilities in a larger theater. While air operations suffered historically when ground commanders used aircraft as additional field artillery, today's corps commanders reject this impression.

The second element of centralized control is the air operations plan. As

explained in Section Two, this plan has two tasks: achieve air superiority and support the JFC's campaign plan. In line with the first task, USAF doctrine is explicit in asserting that the primary operation of the theater air force is to gain control of the aerospace environment. Because the modification occurs after the air component achieves air superiority, this doctrine is not violated. In maintaining with the second task, Air Force doctrine states that all air assets in theater directly support the JFC's campaign plan. With the modified CAS process, the flying units still support the JFC's campaign guidance, only now they are directly synchronized into the ground battle, instead of the air battle. Additionally, these TACAIR units will now comply more closely with the ground commander's intent than the air commander's.

The ATO is the third means of achieving theater "centralized control." From USAF doctrine, the JFACC uses the ATO to control theater air assets and implement the air campaign. With the proposed CAS modification, the JFACC still allocates TACAIR to the corps through the ATO process. The difference is that the air unit remains with the corps for a definite period of time or for a particular task. As discussed in Section Three, the JFACC may reallocate the flying unit if the situation warrants. The proposed CAS system does not discard the ATO process. It only changes procedures for the land component, particularly the corps.

The modified CAS system supports the central tenet of US Air Force doctrine: *Centralized Control - Decentralized Execution*. Because this tenet guides Air

Force operations in the theater fight, it represents the yardstick for evaluating the proposed system. The modified CAS system retains the theater air commander, the air concept of operations, and the general ATO process. The modified CAS system satisfies this analysis while remaining within Air Force doctrine.

Army Doctrine Analysis. Section Two analyzed the current CAS distribution system with the Army tenets, which represent the corps commander's spectrum for viewing the battlefield. How the corps commander fights is colored by *Agility, Synchronization, and Initiative*. The proposed CAS system modifies the current procedures in two ways: task organizing the air unit directly to the corps and increasing the liaison elements between the corps and flying unit. Because Section Two defined each tenet, this section offers only a brief description of each tenet, then analyzes the impact of the two modifications.

Agility

*Agility is the ability of friendly forces to react faster than the enemy and is a prerequisite for seizing and holding the initiative.*³ "Quickness" is the basis for this tenet. The proposed CAS changes allow timely reactions to enemy actions because the chain of command is more efficiently streamlined. The corps' agility increases because the altered system allows the corps commander to reallocate his TACAIR assets and concentrate them at the decisive time and place. Here again, because the air units are under his command and in his task organization,

the corps commander can quickly react to enemy maneuver.

Synchronization

*Synchronization is arranging activities in time and space to mass at the decisive point.*⁵ The modified system permits the corps to achieve *synchronization* through more effective coordination with the OPCON flying. Increased liaison ensures the air unit conducts timely attacks within the corps' overall scheme of maneuver. As the proposed plan approaches execution; the corps staff clarifies the timing, location, and supporting units. With the liaison teams working directly between the corps and TACAIR unit; any changes to the execution plan are quickly transmitted to the TACAIR unit. This liaison element also acts as a stop gap measure should the enemy situation change during the battle. Here again, the liaison teams can quickly transmit necessary changes to the air asset unit should enemy actions alter the original plan.

Initiative

*Initiative sets or changes the terms of battle by action and implies an offensive spirit in the conduct of all operations.*⁶ This tenet primarily portrays the connection between the Corps Commander's intent and subordinates' actions to produce unity of effort. The proposed CAS system gives the air asset the corps commander's intent during the ALO's and ASOC's coordination meetings with the liaison teams. The pilots flying the airstrike now know the location, attack

altitude, type weapons, and purpose of their actions and how these attacks fit into the corps' scheme of maneuver. More importantly, the pilots understand the significance of the primary and alternate targets within the framework of corps operations. Knowing the corps commander's intent allows the pilots to exercise their initiative and still produce the desired result.

The corps commander fights under the doctrinal influence of *Agility*, *Synchronization*, and *Initiative*. These tenets furnished analysis criteria to determine whether the corps commander maximizes his efforts on the battlefield. The evaluation results clearly establish that the modified CAS system is in agreement with Army doctrine. With these proposed changes in task organization and increased liaison, the modified CAS distribution system enables the corps commander to maximize his combat power.

Marine Doctrine Analysis. As explained in Section Two, Marine doctrine emphasizes homogeneous operations that maximize their forces impact on the battlefield. Section Two also introduced MACCS as equivalent to the Air Force and Army's CAS system. MACCS resulted from their efforts to combine organizational and philosophical doctrine to produce greater combat power in battle. It significantly differed from the current CAS system in its organization and command philosophy. When analyzed, the proposed CAS system is comparable with the MACCS for organization and command philosophy.

MACCS, as described in Section Two, results from the aviation wing and its

control element being assigned directly to the MAGTF. This organization causes the MAW and MACG to be directly responsible to the MAGTF commander, and to work for him under the MACCS. With the modified CAS system, this organization is duplicated in the Army corps. Now, not only the ALO and the ASOC, but also the apportioned TACAIR unit are responsible to the corps commander.

The proposed CAS system parallels in command philosophy. As analyzed in the Army tenets above, the "new" command philosophy matches Marine doctrine found in MACCS. The Marines attempt, to create homogeneous operations, results from initiative. The proposed CAS system also allows initiative that insures unity of effort on the battlefield. Both systems attempt to maximize their efforts in this manner.

The proposed CAS system is comparable to MACCS when evaluated, because they contain similar elements of organization and command philosophy. These elements stress unity of effort (Marine homogeneous operations) to maximize their forces on the battlefield. Both elements allow the Marine Corps to harmonize activities between its aviation and ground force during MAGTF operations. With the "new" CAS process, the corps would harmonize its operations in a similar manner.

Summary. The proposed CAS distribution system adequately maximizes combat power in support of corps operations. First, the CAS proposal remained

consistent with USAF doctrine, while altering only slightly the Air Force's theater ATO process. Second, the Army doctrine analysis demonstrated that the CAS modifications increased the command relationships, coordination and unity of effort necessary to maximize ground and air operations. Third, the Marine Corps doctrine examination revealed that the proposed CAS system paralleled their system of harmonizing aviation and ground operations through MACCS. The result of this section's analysis displayed that the modified system enhances the corps commander's ability to maximize combat force for his tactical battle.

CONCLUSION

Answering the Question

Should the CAS distribution process as practiced under the ATO system be modified to task organize apportioned USAF assets into the corps organization for definite period of time or tasks? As the number of ground combat forces shrink, the corps' TACAIR assets becomes increasingly important. While the corps commander experiences few difficulties in preparing his armor, infantry, artillery, and Army aviation units for battle; the current CAS distribution system hinders concentrating his distributed air assets. This monograph analyzed the dilemmas facing the corps commander as he uses the CAS process to employ his air assets.

The definitive Air Force and Army doctrine for the CAS system examined the appropriate, current service doctrine that influence the distribution and employment of theater air assets in support of corps operations. This examination reviewed keystone USAF doctrine and then, studied the CAS distribution system under the current ATO system. This review revealed that four staff elements operated between the corps and the TACAIR support unit. It further explained the corps' connection into the ATO process and the elements that implement CAS operations. The explanation featured the fact that the ALO and ASOC are operationally controlled by the JFACC's AOC. The foundations laid out in this analysis were applied in the next section to evaluate the existing

CAS distribution system.

The analysis of the CAS distribution system revealed that combat power in support of corps operations is not adequately maximized on the battlefield. The Gulf War demonstrated problems resulting from ATO procedural delays, mission changes, and target selection. Both corps commanders experienced frustration with the current CAS system that affected their operations. The analysis of this system under Army doctrine revealed further problems when implementing the tenets of *agility, synchronization, and initiative*. These problems occurred because of command, coordination, and organization difficulties detracted from the corps' ability to concentrate its combat power. The Marine doctrine evaluation revealed similar problems with organization and command philosophy affecting the USAF CAS system. These three difficulties provided the basis for proposing a modified CAS system, which features changes in command, coordination, and organization.

The proposed CAS distribution system solves the battlefield maximization problems identified during the analysis of the current USAF CAS system. This proposal permits the corps a more direct link with the supporting TACAIR assets. The modifications occur after air superiority is achieved, and remain within the procedures of the current USAF ATO system. First, the proposal adjusts the CAS distribution system to directly distribute air assets to the corps commander. This proposal builds on the ATO process with the JFACC apportioning air units

directly to the corps in an OPCON command relationship. Second, this proposal modifies the Corps ASOC by increasing the liaison responsibility between the corps and the supporting air unit. Significantly, these two modifications function within the current system.

An analysis of the proposed CAS distribution system revealed adequate concentration of combat power on the battlefield. This CAS proposal remained consistent with USAF doctrine, while only slightly altering the Air Force's theater ATO process. Army doctrinal analysis demonstrated that the CAS modifications increased the command relationships, coordination, and unity of effort necessary to maximize ground and air operations. The Marine Corps doctrine examination disclosed that the proposed CAS system paralleled their system of harmonizing aviation and ground operations through MACCS.

The proposed modifications to the CAS distribution system assist the corps commander to maximize combat power. The CAS modifications recommended affect command relationships, coordination and unity of effort; elements essential to maximizing ground and air combat power. Two modifications are proposed. The first one is to slightly alter the ATO process by apportioning TACAIR units, and not aircraft, OPCON to the corps for definite periods or tasks. The second proposal features liaison teams between the corps and apportioned air unit that coordinate through the corps ASOC. Both proposals remain consistent with USAF and Army doctrine and require minimal personnel modifications. Yes,

these two innovations enhance the corps commander's ability to maximize his combat force on the battlefield.

ENDNOTES

SECTION ONE

Defining Air Force and Army Doctrine

1. U.S. Air Force, Air Force Manual Volume 1-1: Basic Aerospace Doctrine of the United States Air Force, (Washington, D.C., March 1992), pages 7 and 8. (Hereafter cited as AFM 1-1.) AFM 1-1 defines the basic tenets of Air Force operations. The tenet of *centralized control - decentralized execution* ranks first on this list. The following is the definition of this tenet.

Aerospace forces should be centrally controlled by an airman to achieve advantageous synergies, establish effective priorities, capitalize on unique strategic and operational flexibilities, ensure unity of purpose, and minimize the potential for conflicting objectives. Execution of aerospace missions should be decentralized to achieve spans of control, responsiveness, and tactical flexibility.

Armed Forces Staff College, Armed Forces Staff College Publication 2: Service Warfighting Philosophy and Synchronization of Joint Forces, (Norfolk, Virginia, August 1992), pages I-4-4 and I-4-5. This paragraph contains a brief review of the historical evolution of the employment of USAF assets and the relationship to a central commander. (Hereafter cited as AFSC Pub 2.)

2. AFSC Pub 2, pages I-4-4 and I-4-5. This paragraph paraphrases the duties of the central commander (JFACC) as presented in this reference.

3. AFM 1-1, p 10. This paragraph presents a paraphrase of the priority for achieving air superiority as presented in this reference.

AFSC Pub 2, pages I-4-5 through I-4-7, and I-4-11. This paragraph provides a paraphrase of the priority for achieving air superiority as presented in this reference.

4. AFSC Pub 2, pages I-4-1 and I-4-3. This paragraph paraphrases the USAF philosophy for the development and implementation of the air concept of operations (air campaign plan).

5. The Joint Chiefs of Staff, Joint Publication 3-56.24, Tactical Command and Control Planning Guidance and Procedures for Joint Operations, (Washington, D.C., October 1991), pages III-57 through III-84. (Hereafter cited as Joint Pub 3-56.24). Figure 1 - ATO Process is based on the ATO System diagrams found on

pages III-79 to III- 84; Figures III-13 through III-84.

6. U.S. Army, Field Manual 100-15, Corps Operations, (Draft), (Washington, D.C., 15 July 1994), page 4-60. (Hereafter cited as FM 100-15 [DRAFT]). This reference describes the relationship of the theater commander (JFC) to his air component and land component commanders (ACC and LCC, respectively). This relationship is paraphrased in this paragraph.

U.S. Army and U.S. Air Force, Field Manual 90-28 & Tactical Air Command Pamphlet 50-45: Tactical Air Planning and Employment in Support of Ground Operations, (Fort Monroe, Virginia, September 1991), pages 2-5 through 2-7. (Hereafter cited as FM 90-28 & TACP 50-45). These pages provide a detailed review of the relationships of the JFC to his ACC and LCC.

7. Joint Pub 3-56.24, pages III-57 through III-84. This publication represents the doctrine for the ATO process, which is paraphrased in these paragraphs.

Lt Col Tom Gorman, "Top Down Planning the ATO and CAS", Air Land Sea Application Bulletin, (Number 94-2, September 1994), pages 13 to 17. This article provides a briefer description of the ATO process.

8. FM 100-15 [DRAFT], page 4-64 through 4-65. This paragraph paraphrases a description of the relationship between the ASOC, AOC, and Corps Staff.

9. FM 100-15 [DRAFT], page 4-61. This figure represents a stylized version of FM 100-15's Figure 4-8 to illustrate the links between the Corps Staff, BCE, ASOC, AOC, JFACC, JFLCC, and JFC.

10. FM 100-15 [DRAFT], page 4-66. This paraphrase describes the functions of the ASOC and its relationships to the Corps Staff.

11. FM 100-15 [DRAFT], page 4-65. This figure presents a stylized version of relationships within the Corps Staff and the ASOC to include the USAF personnel positions.

12. FM 100-15 [DRAFT], pages 4-67 through 70. These pages are paraphrased, and represent a description of the particular elements of the Corps ASOC that manage CAS support.

SECTION TWO

Evaluating the CAS distribution system

1. John H. Cushman, LTG(R), Thoughts for Joint Commanders, (Annapolis, Maryland, August 1993), pages 35 through 40. This reference provides a view with examples of the reasons air and land commanders, at levels lower than the JFACC or JFLCC, follow different approaches to the battle.

2. Edward J. Francis (Maj), Is Current Fire Support Doctrine for the Deep Battle Effective in the Post Desert Storm Environment?, (Fort Leavenworth, Kansas; Army Command and General Staff College, 1993), pages 79 through 91. (Hereafter cited as Desert Storm Environment.) MAJ Francis provides first hand evidence of the frustration experienced by the Corps Staff concerning the disconnect in targeting.
Robert H. Scales (BG) Certain Victory: The US Army in the Gulf War, (Fort Leavenworth, Kansas; Army Command and General Staff College, 1994), pages 188 and 189. (Hereafter cited as Certain Victory) This reference additionally details the frustration of the corps commanders with the air support system.
H. Norman Schwartzkopf (GEN), It Doesn't Take A Hero, (New York; Bantam Books, 1992), pages 319, 320, and 353 through 365. GEN Schwartzkopf reveals that the air campaign was completed first, and lead the ground campaign plan. While this evidence is not included for analysis, it does explain part of the reason for the corps commanders' frustrations.

3. Keaney, Thomas A. and Cohen, Eliot A., Gulf War Air Power Survey Summary Report, (Washington, D.C. U.S. Government Printing Office, 1993), page 156. (Hereafter cited as Gulf War.) Since the Marines employed much of their own air power for bombing tactical targets, they were relatively satisfied.

4. Gulf War, page 160. A paraphrase of the three factors that suggest the Gulf War was an aberration in the employment of air power.

5. Gulf War, pages 148, 149, and 160. These pages provide evidence for the air concept of operations based on a theater campaign plan during the Gulf War.
Richard B. H. Lewis (COL), "JFACC Problems Associated with Battlefield Preparation in Desert Storm," Airpower Journal, (Maxwell AFB, Alabama; Air

University Press, Spring 1994) pages 4 and 5. (Hereafter cited as Airpower Journal.) This source furnishes additional evidence for the concept of operations based on the JFC's campaign plan.

6. Gulf War, page 159. This source contributes evidence of the value of a single commander for the air assets in theater.

Airpower Journal, pages 19 and 20. While this entire article features the discussion of a single air commander, the main arguments for a JFACC appear on these pages.

7. Gulf War, page 156. This page features evidence of the success of "PUSH" CAS.

Certain Victory, pages 188 and 189. These pages provide evidence of success of GEN Horner's "PUSH" CAS system.

8. Gulf War, page 150. Reference presents evidence of ATO taking too long to publish, transmit, and receive by executing unit.

Certain Victory, page 368 and 370. Page 368 emphasizes that historically, CAS planning took 24-hours, now with ATO requires 72-hours. Page 370 argues that in the future the Air Force must shorten planning time to get pilot into battle quicker.

9. Gulf War, pages 150 and 151. Page 150 has evidence that GEN Glosson was prone to calling wing commanders with last minute changes. Page 151 cites evidence that the ATO was subject to change by the JFACC and senior planners.

Certain Victory, page 189. This page mentions airborne command and control elements making changes during ATO execution.

Rick Atkinson, Crusade: The Untold Story of the Persian Gulf War, (New York; Houghton Mifflin Company, 1993) pages 216 through 223. (Hereafter cited as Crusade.) Mr. Atkinson relates that Glosson changed targets after the Deputy JFC, GEN Waller, made decision on targets.

10. Desert Storm Environment, pages 79 through 91. The author offers first hand evidence of targeting frustration experienced at the Corps Staff level.

Gulf War, page 152. This page presents the dispute over armor and artillery targeting.

Crusade, pages 219 through 221. The author also points out evidence of the dispute between armor and artillery targets. Additionally, he mentions dispute between the Army and Air Force over strategic, operational and tactical targeting

priorities. He points out that on a typical nomination just over a third would be flown against targets nominated by the ground component.

11. U.S. Army, FM 100-5, Operations, (Washington, D.C., Government Printing Office, 14 June 1993), page 2-6. (Hereafter cited as FM 100-15.) A paraphrase of the doctrinal definition of *tenets*, which relates the tenets as tools for employing combat forces.

12. FM 100-5, page 2-7. The italicized sentence is a direct quote, while the remainder is a paraphrased description of AGILITY.

13. Certain Victory, page 370. This page discusses the future task of getting the pilot to the battle much quicker than during Desert Storm.

Joint Pub 3-56.24 and Figure 1 from Section One show the four staffs that interact for providing CAS support to the corps commander.

14. FM 100-5, pages 2-8 and 2-9. The italicized sentence is a direct quote, while the remainder is a paraphrased description of SYNCHRONIZATION.

15. Gulf war, page 150. This page lists two pieces of evidence. The first piece cites a comment that the ATO attempted to run a war on a time schedule. The second piece concerns the ATO as a method to efficiently use aircraft based on timing their activities.

16. FM 100-5, pages 2-8, 2-9 and 6-3. The first two pages define SYNCHRONIZATION. Page 6-3 explains engagements as parts (events) fitting together to make up a larger battle. Time is not mentioned.

17. FM 100-5, pages 2-6 and 2-7. The italicized sentence is a direct quote, while the remainder is a paraphrased description of INITIATIVE.

18. Gulf war, page 150. This page provides the specifics on the ATO mission: time on target, mission number, target number, target name, aircraft type, numbers of aircraft, munitions load, communications procedures, air refueling procedures, airspace control, rescue procedures, and jamming procedures.

19. U.S. Marine Corps, Fleet Marine Force Reference Publication 1-11, Fleet Marine Force Organization, (Quantico, Virginia, March 1992), page 3-1 and 3-2. (Hereafter cited as FMFRP 1-11.) This sentence contains a paraphrases that concerns Marine emphasis on homogeneous operations in which Marine units are stronger as part of a whole than when separated.

20. FMFRP 1-11, pages 2-1 through 2-5. The MAGTF usually consists of a Marine Division, a Marine Aviation Wing, and a Combat Service Support Element. These pages contain notional figures showing the organization of the MAGTF and its elements.

21. FMFRP 1-11, pages 5-1 through 5-8. These pages describe the MAW and MACG responsibilities to the MAGTF.

U.S. Marine Corps, Fleet Marine Field Manual 5-1 Marine Aviation, (Washington, D.C., 1979), pages 173 through 177. These pages describe the command responsibilities of the MAGTF commander and his subordinate commanders. The MAGTF (Commander Landing Force -- CLF) is responsible for overall plan and his subordinates for execution in compliance with his scheme of maneuver.

22. U.S. Marine Corps, Fleet Marine Field Manual 1-1 Warfighting, (Washington, D.C., March 1989), page 61. (Hereafter cited as FMFM 1-1.) This passage is a direct quote.

23. FMFM 1-1, page 66. This passage is a direct quote.

SECTION THREE

Proposing a Modified CAS System

1. Joint Pub 3-56.24, pages III-57 through III-84. Figure 4 - ATO Process is a modification of the ATO System diagrams found on pages III-79 to III- 84; Figures III-13 through III-84. The modification concerns the change represented by the gray, two-headed arrows for task organization of flying units between the Corps and AOC.

2. Armed Forces Staff College, Armed Forces Staff College Publication 1: Service Warfighting Philosophy and Synchronization of Joint Forces, (Norfolk, Virginia; U.S. Government Printing Office, 1993), page I-32. This reference is paraphrased for the definition of Operational Control (OPCON).

The Joint Chiefs of Staff, Joint Publication 5-00.1, Doctrine for Joint Campaign Planning (INITIAL DRAFT), (Washington, D.C.; June 1992), pages GL-14 and GL-15. This additional reference is paraphrased for the joint definition of Operational Control.

3. FM 100-15 [DRAFT], page 4-61. This figure represents a modification of FM 100-15's Figure 4-8 to illustrate the "new" coordination link between the Corps Staff, the ASOC, and the AOC.

4. FM 100-15 [DRAFT], page 4-65. This modified figure represents the "new" coordination link between the flying unit, the ASOC, and the corps staff with the introduction of liaison personnel. Additionally, the figure depicts the command relationship between the corps commander and the flying unit.

SECTION FOUR

Evaluating the Modified CAS System

1. FM 100-15 [DRAFT], pages 4-70 through 4-88. These pages describe the situation when the corps becomes a JTF.

2. FM 100-5, page 2-7. The italicized sentence is a direct quote of AGILITY.

3. FM 100-5, pages 2-8 and 2-9. The italicized sentence is a direct quote of SYNCHRONIZATION.

4. FM 100-5, pages 2-6 and 2-7. The italicized sentence is a direct quote of INITIATIVE.

BIBLIOGRAPHY

Primary Sources

Official Records

The Joint Chiefs of Staff. Joint Publication 3-56.24, Tactical Command and Control Planning Guidance and Procedures for Joint Operations. Washington, D.C.: U.S. Government Printing Office, October 1991.

Joint Publication 5-00.1, Doctrine for Joint Campaign Planning, (INITIAL DRAFT). Washington, D.C.: U.S. Government Printing Office, June 1992.

Armed Forces Staff College, Armed Forces Staff College Publication 2: Service Warfighting Philosophy and Synchronization of Joint Forces, Norfolk, Virginia: U.S. Government Printing Office, August 1992.

The Joint Staff Officers Guide 1993. Norfolk, Virginia: U.S. Government Printing Office, 1993.

U.S. Air Force. Air Force Manual Volume 1-1: Basic Aerospace Doctrine of the United States Air Force. Washington, D.C.: U.S. Government Printing Office, March 1992.

U.S. Army. Field Manual 100-15, Corps Operations, (Draft). Washington, D.C.: U.S. Government Printing Office, 15 July 1994.

FM 100-5, Operations. Washington, D.C.: U.S. Government Printing Office, 14 June 1993.

U.S. Army and U.S. Air Force. Field Manual 90-28 & Tactical Air Command Pamphlet 50-45: Tactical Air Planning and Employment in Support of Ground Operations. Fort Monroe, Virginia: September 1991.

U.S. Marine Corps, Fleet Marine Field Manual 1-1, Warfighting. Washington, D.C.: U.S. Government Printing Office, March 1989.

Fleet Marine Field Manual 5-1, Marine Aviation. Washington, D.C.: U.S. Government Printing Office, September 1991.

Fleet Marine Force Reference Publication 1-11, Fleet Marine Force Organization. Quantico, Virginia: U.S. Government Printing Office, March 1992.

Keaney, Thomas A. and Cohen, Eliot A., Gulf War Air Power Survey Summary Report. Washington, D.C.: U.S. Government Printing Office, 1993.

Scales, Robert H. (BG) Certain Victory: The US Army in the Gulf War. Fort Leavenworth, Kansas; Army Command and General Staff College, 1994.

H. Norman Schwartzkopf (GEN), It Doesn't Take A Hero, New York; Bantam Books, 1992.

Official Periodicals

Gorman, Tom. (Lt Col) "Top Down Planning the ATO and CAS." in The Air Land Sea Application Bulletin. Langley Air Force Base, Virginia: Air Land Sea Application Center, Number 94-2, September 1994.

Lewis, Richard B. H. (Col) "JFACC, Problems Associated with Battlefield Preparation in Desert Storm." in Airpower Journal. Maxwell Air Force Base, Alabama: Air University Press, Volume VIII, Number 1, Spring 1994.

Secondary Sources

Individual Study Projects

Cushman, John H. LTG(R). Thoughts for Joint Commanders. Annapolis, Maryland: Whitmore Printing, August 1993.

Bell, S.E. Close Air Support for the Future, Fort Leavenworth, K.: Army Command and General Staff College, 1992.

Chau, A.F. How to Employ Airpower on the Battlefield, Maxwell AFB, AL.: Air War College, 1990.

Combest, M.L. Apportionment and Tactical Airpower in Airland Battle -- An Evaluation of CAS (Close Air Support), BAI (Battlefield Air Interdiction), and AI (Air Interdiction) from an Operational Perspective, Fort Leavenworth, KS.: Army Command and General Staff College, 1987.

Francis, E.J. Is Current Fire Support Doctrine for the Deep Battle Effective in the Post

- Desert Storm Environment, Fort Leavenworth, KS.: Army Command and General Staff College, 1993.
- Flock, J.F. CAS, Service Doctrine, and the Operational Level of War, Newport, RI.: Naval War College, 1993.
- Foret, H.L. Close Air Support: A Case of Joint Operational Capability or Joint Rhetoric, Newport, RI.: Naval War College, 1992.
- Jordan, D.W. Tactical Airpower and the Operational Level of War, Fort Leavenworth, KS.: Army Command and General Staff College, 1990.
- Lang, R.H. Alphabet Soup: Command and Control of Tactical Air Sorties, Fort Leavenworth, KS.: Army Command and General Staff College, 1991.
- What Do We Do Now? Air Power Use After Gaining Air Superiority, Fort Leavenworth, KS.: School of Advanced Military Studies, 1992.
- Simm, R.K. Operation Desert Storm and a New Paradigm: Ground Forces in Support of Air Operations, Fort Leavenworth, KS.: Army Command and General Staff College, 1993.

RESEARCH SOURCES

- Leedy, Paul D. Practical Research: Planning and Design, New York: MacMillin Publishing Company, 1989.
- Hillway, Tyrus Introduction to Research, Boston: Houghton Mifflin Company, 1964.