



**SURVIVABILITY • SUSTAINABILITY • MOBILITY  
SCIENCE AND TECHNOLOGY  
SOLDIER SYSTEM INTEGRATION**



**TECHNICAL REPORT  
NATICK/TR-95/026**

AD \_\_\_\_\_

# **VENTILATION SYSTEM FOR THE MOBILE KITCHEN TRAILER**

**By  
Keith Nelson  
Dale Snyder  
Don Pickard**

**MAY 1995**

**FINAL REPORT  
November 1991 - September 1994**

**Approved for Public Release; Distribution Unlimited**

**DTIC QUALITY INSPECTED 6**

**U.S. ARMY SOLDIER SYSTEMS COMMAND  
NATICK RESEARCH, DEVELOPMENT AND ENGINEERING CENTER  
NATICK, MASSACHUSETTS 01760-5018**

**SUSTAINABILITY DIRECTORATE**

19950524 021

## DISCLAIMERS

The findings contained in this report are not to be construed as an official Department of the Army position unless so designated by other authorized documents.

Citation of trade names in this report does not constitute an official endorsement or approval of the use of such items.

## DESTRUCTION NOTICE

### For Classified Documents:

Follow the procedures in DoD 5200.22-M, Industrial Security Manual, Section II-19 or DoD 5200.1-R, Information Security Program Regulation, Chapter IX.

### For Unclassified/Limited Distribution Documents:

Destroy by any method that prevents disclosure of contents or reconstruction of the document.

# REPORT DOCUMENTATION PAGE

Form Approved  
OMB No. 0704-0188

Public reporting burden for this collection of information is estimated to average 1 hour per response, including the time for reviewing instructions, searching existing data sources, gathering and maintaining the data needed, and completing and reviewing the collection of information. Send comments regarding this burden estimate or any other aspect of this collection of information, including suggestions for reducing this burden, to Washington Headquarters Services, Directorate for Information Operations and Reports, 1215 Jefferson Davis Highway, Suite 1204, Arlington, VA 22202-4302, and to the Office of Management and Budget, Paperwork Reduction Project (0704-0188), Washington, DC 20503.

1. AGENCY USE ONLY (Leave blank)	2. REPORT DATE May 1995	3. REPORT TYPE AND DATES COVERED FINAL Nov 1991 - Sept 1994
----------------------------------	----------------------------	--

4. TITLE AND SUBTITLE Ventilation System for the Mobile Kitchen Trailer	5. FUNDING NUMBERS PR CPIB
--	-------------------------------

6. AUTHOR(S) Keith Nelson, Dale Snyder and Don Pickard	
---	--

7. PERFORMING ORGANIZATION NAME(S) AND ADDRESS(ES) U.S. Army Soldier Systems Command (SSCOM) Natick Research, Development and Engineering Center ATTN: AMSSC-WEA Natick, MA 01760-5018	8. PERFORMING ORGANIZATION REPORT NUMBER NATICK/TR-95/026
--	--

9. SPONSORING / MONITORING AGENCY NAME(S) AND ADDRESS(ES)	10. SPONSORING / MONITORING AGENCY REPORT NUMBER
---	--

11. SUPPLEMENTARY NOTES
-------------------------

12a. DISTRIBUTION / AVAILABILITY STATEMENT Approved for Public Release; Distribution Unlimited	12b. DISTRIBUTION CODE
---	------------------------

13. ABSTRACT (Maximum 200 words) The Mobile Kitchen Trailer (MKT) uses 6 M-2 gasoline burners to heat a griddle, range cabinets and cooking racks. These cooking appliances do not currently have any type of chimney or vent, so all combustion products from the burners go into the kitchen. Accordingly, a ventilation system (i.e. equipment vents) was designed, fabricated and tested for the MKT to reduce the probability of clinical symptoms that have ranged from mild irritations to possible hypoxia. The equipment vents reduced the carbon monoxide concentration by 89 percent (15.3 ppm to 1.7 ppm), and the percent oxygen was increased by 35 percent (19.4 to 20.4%). The formaldehyde concentration was reduced from 0.37 ppm (exceeding the Threshold Limit Value), to 0.05 ppm, an 86 percent decrease. The equipment vents also reduced the temperature difference between the floor and ceiling by 35°F and increased the efficiency of the grill by 53 percent. Combustion products for the M-2 and M-3 burners also were compared. The equipment vents are recommended for use within the MKT as a means of providing a safer cooking environment for military personnel.
--

14. SUBJECT TERMS MOBILE KITCHENS                      MKT (MOBILE KITCHEN TRAILERS)                      SAFETY VENTILATION SYSTEM                      COMBUSTION PRODUCTS                      AIR QUALITY KITCHEN BURNERS                      CARBON MONOXIDE                      FORMALDEHYDE	15. NUMBER OF PAGES 82
	16. PRICE CODE

17. SECURITY CLASSIFICATION OF REPORT UNCLASSIFIED	18. SECURITY CLASSIFICATION OF THIS PAGE UNCLASSIFIED	19. SECURITY CLASSIFICATION OF ABSTRACT UNCLASSIFIED	20. LIMITATION OF ABSTRACT SAR
---	--	---	-----------------------------------

TABLE OF CONTENTS

	<u>Page</u>
LIST OF FIGURES.....	v
LIST OF TABLES.....	ix
PREFACE.....	xi
SYMBOLS, ABBREVIATIONS, AND ACRONYMS.....	xiii
INTRODUCTION.....	1
BACKGROUND.....	5
OBJECTIVE.....	7
APPROACH.....	7
First Approach.....	7
Second Approach.....	7
Baseline for Testing.....	10
INSTALLATION PROCEDURE.....	11
Installation of Equipment Vents.....	11
TESTING PROCEDURE.....	15
Procedure for Setting M-2 and M-3 Outputs.....	15
Equipment Vent Test Procedure.....	16
INITIAL TESTS RESULTS.....	17
Equipment Vent Results.....	19
IMPROVED EQUIPMENT VENTS.....	22
Installation of Improved Vents.....	23
Improved Vent Test Procedure.....	25
Second Equipment Vents Results.....	26

TABLE OF CONTENTS (continued)

	<u>Page</u>
FORMALDEHYDE TESTS.....	26
Formaldehyde Testing With Screens Sides.....	29
Formaldehyde Testing With Canvas Sides.....	31
Formaldehyde Test Results.....	31
PERFORMANCE TEST.....	33
Performance Test for Grill.....	33
Performance Test for Griddle.....	35
Performance Testing.....	36
DISCUSSION OF RESULTS.....	40
CONCLUSIONS AND RECOMMENDATIONS.....	42
LIST OF REFERENCES.....	45
APPENDICES.....	47
APPENDIX A: DESIGN/FABRICATION PROCEDURE.....	49
APPENDIX B: TEST EQUIPMENT & CALIBRATION.....	63
APPENDIX C: M-2 VERSUS M-3 BURNER.....	67

Accession For	
NTIS CRA&I	<input checked="" type="checkbox"/>
DTIC TAB	<input type="checkbox"/>
Unannounced	<input type="checkbox"/>
Justification .....	
By .....	
Distribution /	
Availability Codes	
Dist	Avail and/or Special
<b>A-1</b>	

## LIST OF FIGURES

<u>Figure</u>	<u>Title</u>	<u>Page</u>
1.	Mobile Kitchen Trailer (MKT) with canvas sides.	1
2.	Mobile Kitchen Trailer (MKT) with screen sides.	2
3.	M-59 Range Cabinets used in the MKT.	3
4.	Griddle and Grill used in the MKT.	4
5.	Placement of thermoelectric converters on the bottom of a 15 gallon stock pot.	8
6.	Placement of thermoelectric-powered fan assembly in the Mobile Kitchen Trailer's roof vent.	9
7.	MKT's location for testing	11
8.	Permanent roof vents on the MKT tied together for installation of new roof vent.	12
9.	New roof vent covers viewed from inside of the MKT.	12
10.	M-59 Range Cabinet with equipment vent installed.	13
11.	Grill with cowl used for the equipment vents.	13
12.	Cowl and stack used for equipment vents.	14
13.	Griddle and stack used for equipment vent.	15
14.	Gas concentrations and temperature difference within the Mobile Kitchen Trailer when using three M-2 burners at various ambient temperatures.	18
15.	Gas concentrations and temperature difference within the Mobile Kitchen Trailer when using three M-2 burners at an ambient temperature of 45°F (test 1).	20
16.	Gas concentrations and temperature difference within the Mobile Kitchen Trailer when using three M-2 burners at an ambient temperature of 45°F (test 2).	21
17.	M-59 Range Cabinet with the second equipment vent installed.	24

LIST OF FIGURES (continued)

<u>Figure</u>	<u>Title</u>	<u>Page</u>
18.	Cowl and stack used for the second set of equipment vents.	24
19.	Griddle and stack used for the improved equipment vents.	25
20.	Gas concentrations and temperature difference within the Mobile Kitchen Trailer when using three M-2 burners at an ambient temperature of 25°F.	27
21.	Gas concentrations and temperature difference within the Mobile Kitchen Trailer when using three M-2 burners at an ambient temperature of 35°F.	28
22.	M-59 Range Cabinet with the equipment vent used for the formaldehyde testing.	29
23.	TGM 555 monitor and LINEAR chart recorder used for testing formaldehyde.	30
24.	Formaldehyde concentrations within the Mobile Kitchen Trailer when using FIVE M-2 burners and SCREEN SIDES in the nonvent configuration, at an ambient temperature of 53°F.	32
25.	Formaldehyde concentrations within the MKT when using three M-2 burners in the nonvent and equipment vented configurations at an ambient temperature of 52°F and 70°F.	34
26.	Thermocouple configuration on griddle for performance testing of the griddle.	35
27.	Time and efficiency to heat 100 lbs. of water 130°F on the grill in three different configurations without boiling the water during heating.	37
28.	Griddle temperature comparison when using two M-3 burners in the griddle in the nonvent and equipment vented configuration.	38
29.	Griddle contour temperature plots for the nonvent and equipment vented configuration.	39

LIST OF FIGURES (continued)

<u>Number</u>	<u>Title</u>	<u>Page</u>
A-1.	Drawing plan for first equipment vent for the M-59 Range Cabinet.	51
A-2.	Drawing plan for the first equipment vent for the Grill.	52
A-3.	Drawing plan for the first equipment vent for the Griddle.	53
A-4.	Drawing plan for Duct Plate to hold galvanized duct on Griddle Riser (figure 10).	54
A-5.	Drawing plan for substitute Roof Vent Cover to replace MKT roof vent for testing equipment vents.	55
A-6.	Drawing plan for second equipment vent for the M-59 Range Cabinet.	57
A-7.	Drawing plan for the second equipment vent for the Grill.	58
A-8.	Flexible tubes used for stacks with the second set of equipment vents.	59
A-9.	Drawing plan for Chimney Collar design.	60
A-10.	Ventilation Retrofit Kit for Mobile Kitchen Trailer	61
A-11.	Drawing plan for Cowl-#2 with half-moon plate added for improved performance of the Grill.	62
B-1.	Exotox 75 Gas Monitor and System Data Interface for downloading data to the computer.	64
C-1.	M-3 burners versus M-2 burners for carbon monoxide and oxygen concentration in the Mobile Kitchen Trailer in the nonvent configuration at an ambient temperature of 25°F	69
C-2.	M-3 burners versus M-2 burners for carbon monoxide and oxygen concentration in the Mobile Kitchen Trailer in the nonvent configuration at an ambient temperature of 35°F	70

LIST OF TABLES

<u>Table</u>	<u>Title</u>	<u>Page</u>
1.	ACGIH Threshold Limit Values (TLVs)	6
2.	Sulfur Content of Fuels <sup>3</sup> (% by weight)	17
3.	Summary of Results	40

## PREFACE

This effort was undertaken by the Advance Technology Branch of U.S. Army Soldier Systems Command, (SSCOM) Natick Research, Development and Engineering Center, (NRDEC) to evaluate methods for improving the air quality conditions in the Mobile Kitchen Trailer (MKT). The CPI work unit was primarily in response to the complaints of the air quality in the MKT in winter type conditions. Technical and editorial assistance was provided by Mr. Donald Pickard. Testing and implementation of the designs were performed by Mr. Keith Nelson and Mr. Dale Snyder. Research for this project was started on November 1991 and ended September 1994.

SYMBOLS, ABBREVIATION, AND ACRONYMS

ACGIH	American Conference of Government Industrial Hygienist
Btu	British thermal unit
cfm	cubic feet per minute
CO	carbon monoxide
Cp	specific heat
e.g.	for example
°F	degrees Fahrenheit
ft	feet
gal	gallon
Hc	heat of combustion
HCHO	formaldehyde
hr	hour
i.d.	inside diameter
i.e.	that is
KCL	Kitchen Company Level
lbs.	pounds
Max	maximum
min	minute
MKT	Mobile Kitchen Trailer
mph	miles per hour
NO <sub>2</sub>	nitrogen dioxide
NO <sub>x</sub>	nitrogen compounds (NO & NO <sub>2</sub> )
O <sub>2</sub>	oxygen gas
ppm	parts per million
Qr	heat rejected or capacity
RH	Relative Humidity
SO <sub>2</sub>	sulfur dioxide
std. dev.	standard deviation
t	time
ΔT	temperature change
temp.	temperature
TLV	Threshold Limit Value
Typ.	typical
vs.	versus
W <sub>f</sub>	weight of fuel
W <sub>w</sub>	weight of water

VENTILATION SYSTEM FOR THE  
MOBILE KITCHEN TRAILER

INTRODUCTION

The Mobile Kitchen Trailer (MKT) shown in Figure 1 is an expandable, self-contained, trailer-mounted, field food service system designed to provide food service for approximately 250 personnel per meal. This system consists of standard field cooking equipment packaged in a configuration to allow efficient preparation of type A and B rations. Arrangement of the equipment includes preparation counters, cooking areas and a serving line. The MKT roof is manually raised and the sides are either fabric or screen for environmental protection. A picture of the screen sides in place on the MKT is shown in Figure 2. The kitchen is mounted on a standard 1-1/2-ton M-103A3 trailer chassis. The M-103A3 trailer is designed to be towed by a standard 5-ton tactical vehicle over cross-country, highway terrain, and air-transported under a CH47 helicopter or internally by Air Force cargo aircraft.<sup>6</sup>

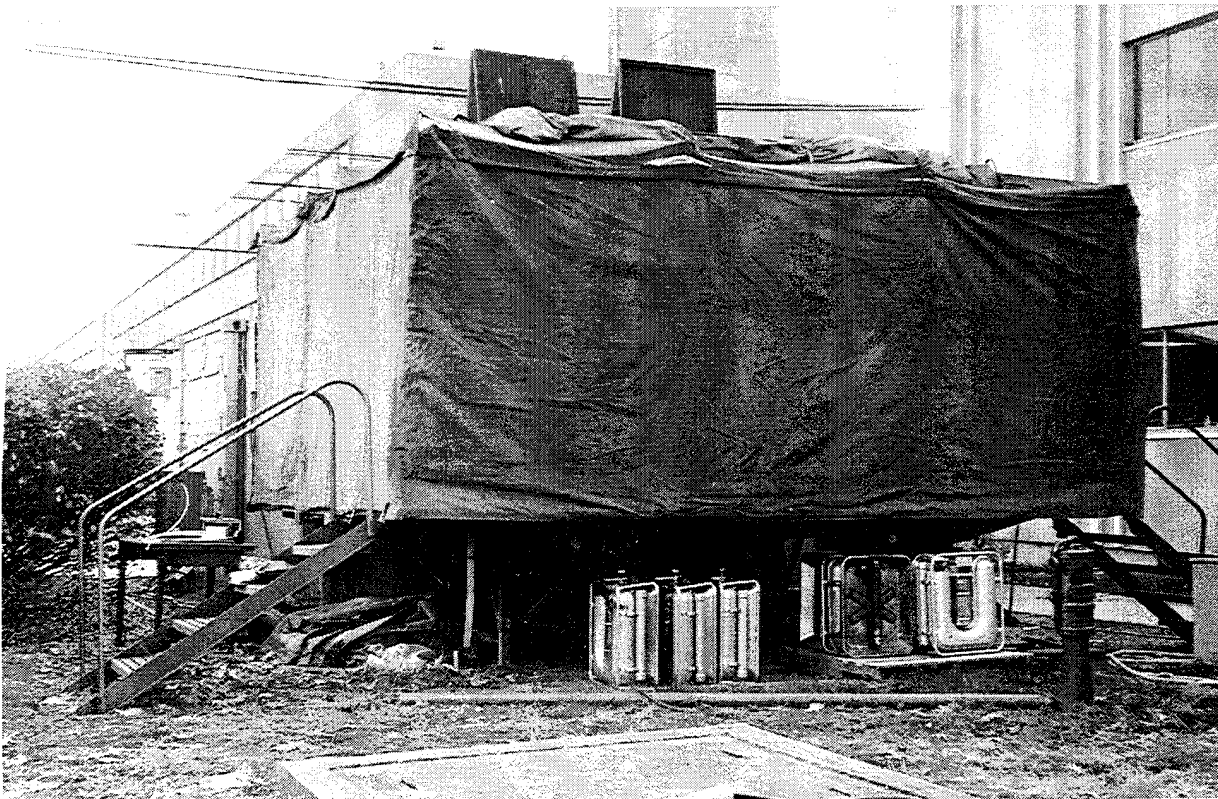

Figure 1. Mobile Kitchen Trailer (MKT) with canvas sides.

The primary advantage of a self-contained MKT is its inherent mobility, which is the ability to move the kitchen facility once it has been cleaned following the preparation of a meal until it is set-up and ready to prepare the next meal at a new site. This includes the take-down, packing, transport, unpacking and set-up, of food service equipment. Setup or take down can be accomplished by four personnel in twenty minutes. The MKT is a self-contained unit, that is its own packing container and does not use or delay an additional vehicle for packing or unpacking.<sup>6</sup>

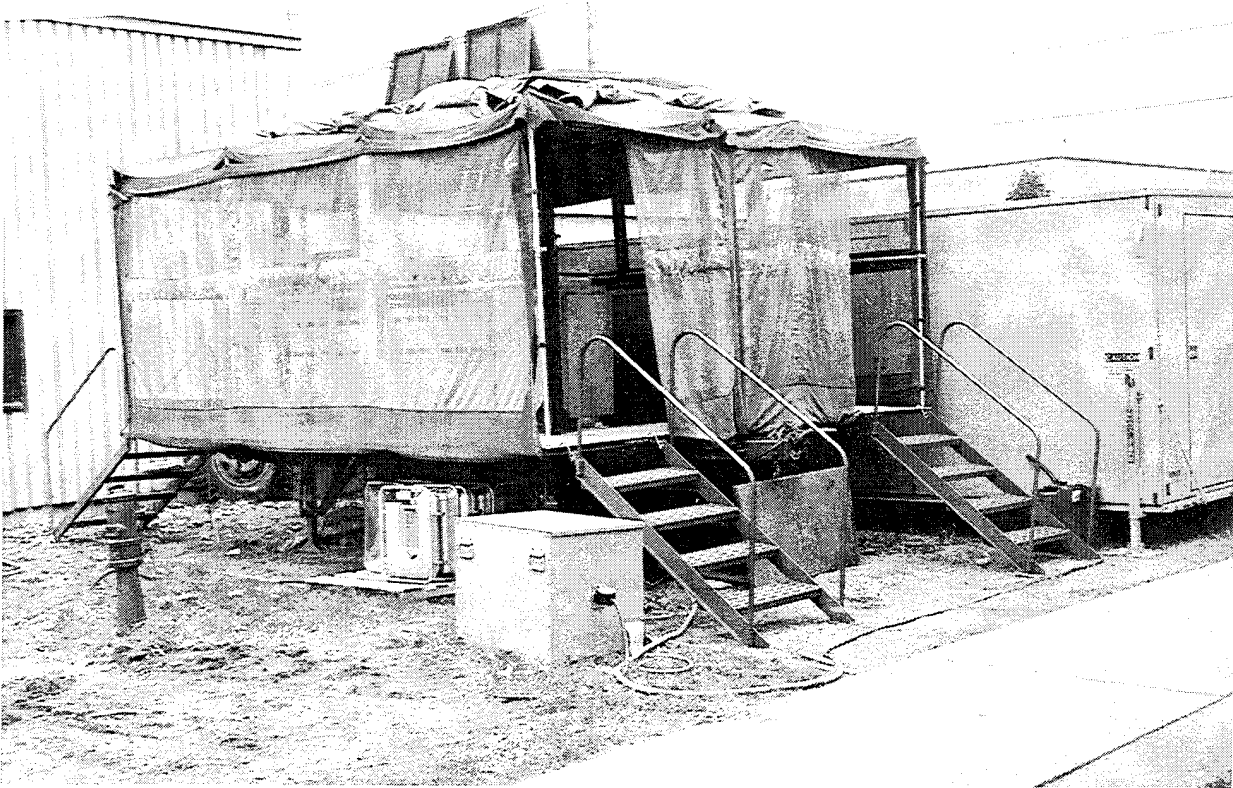

Figure 2. Mobile Kitchen Trailer (MKT) with screen sides.

The MKT's versatility enables it to be deployed as a forward or rear field kitchen. For example, the MKT could be moved to a forward area after dark and detached from the prime mover, freeing that mover for other missions until the MKT is required to move to a rear or new location. The MKT lends itself to consolidation or centralization and is less restricted by extreme climatic and terrain conditions. The work area and the serving line of the MKT are elevated off the ground, vastly improving the sanitation environment for food service personnel and the subsisting personnel.<sup>6</sup>

The MKT's cooking equipment consists of two M-59 range cabinets, one griddle and two grills. The M-59 range cabinet

functions as an oven, it has two positions at the base of the cabinet that the M-2 burner can be placed to vary the intensity of the heat. The top of the M-59 range cabinet can be opened for placing a square-head (deep rectangular pans that include a cover) or a full sized pan for cooking stews or cakes etc. The front of the M-59 range cabinet opens like a conventional oven and has two sliding panels on the front for viewing or cooling the M-59 range cabinet. Square-heads, full sized pans, or a ten or 15-gallon stock pot can be slid into the cabinet from the front. A picture of two M-59 range cabinets is shown in Figure 3.



Figure 3. M-59 Range Cabinets used in the MKT.

The MKT's griddle is large enough for two M-2 burners to fit beneath it. The griddle has a raised edge around the perimeter to contain grease and hold stainless steel sides that prevent grease from splattering on personnel as they walk by in the service line. On the right end of the griddle a hole is cut for a grease chute.

The MKT's grills heat square head pans or stock pots. A picture of the griddle and grill is shown in Figure 4. Only one of the grills is shown in Figure 4, it's on the right-hand side of the picture. The griddle and grill provide a place for food

preparation and for serving hot food in the serving line when square-head warmer adapters or insulated food containers are used. Additional kitchen components for the MKT consist of ice chest, cabinets, sink, field tables, insulated liquid dispensers, water containers and gasoline cans.

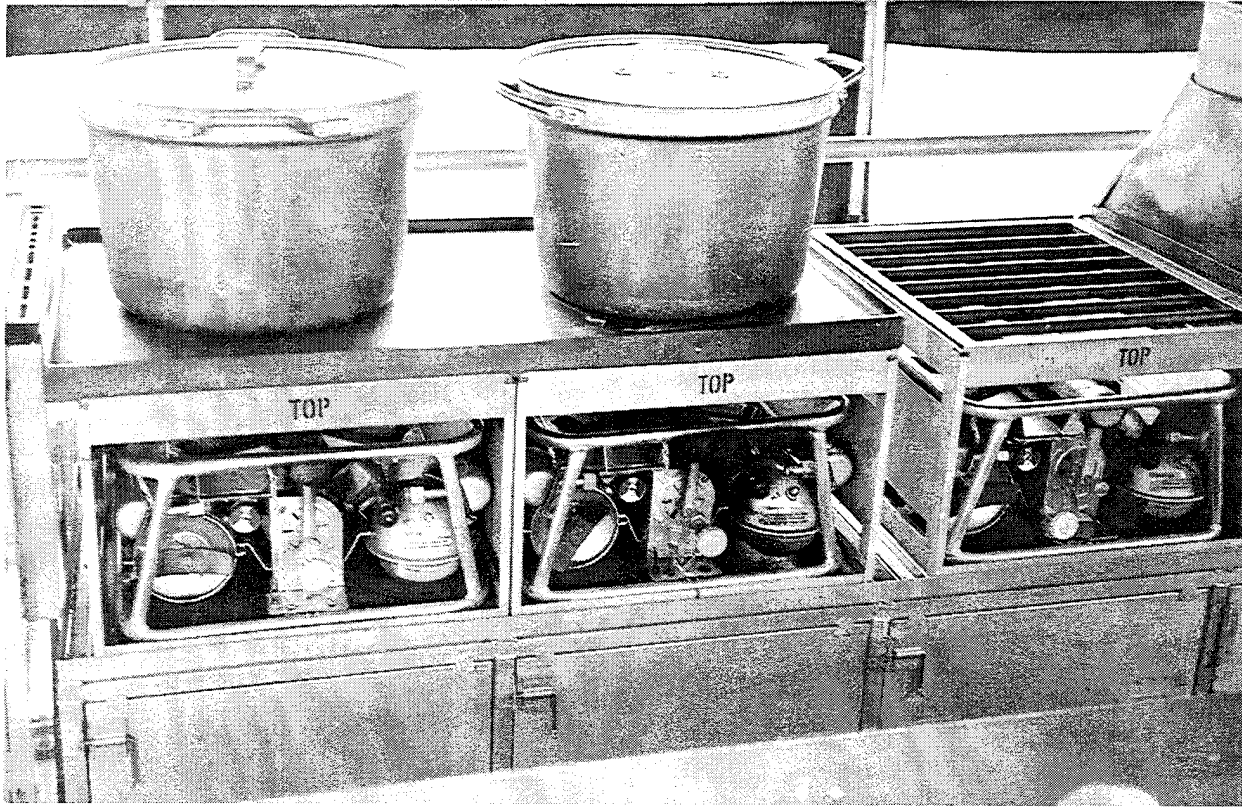

Figure 4. Griddle and Grill used in the MKT

## BACKGROUND

The MKT uses six M-2 burners to prepare rations for personnel. M-2 burners use a single fuel, gasoline, and are rated at a maximum capacity of 60,000 Btu/hr. Because of the poor efficiency of the cooking equipment, a considerable amount of excess heat accumulates within the MKT. In temperate climates, it often becomes necessary to open the roof vents to draft the excess heat out of the MKT. In addition, screen sides are sometimes used for added ventilation. However, in cold climatic conditions the ceiling vents generally need to be closed and the canvas sides are used. When the ceiling vents are closed, combustion products tend to accumulate, occasionally resulting in personnel becoming ill. Personnel who stay within the MKT often do not recognize the accumulation of combustion products and the decline in the air quality unless they leave or have just entered the MKT. Examples of the types of clinical symptoms reported include complaints of eye, nose, throat irritations, occasional headache, dizziness and nausea. The later symptoms are generally found with hypoxia.<sup>2</sup>

Hypoxia is the failure of the body to deliver adequate oxygen to the bodies' tissues. Hypoxia is more serious than the other irritations (i.e. eye, nose and throat irritations). Two primary conditions that contribute to hypoxia are a reduction in the percentage of oxygen and an increase of the concentration of carbon monoxide. One hidden danger from this situation is the oxygen and carbon monoxide readings can be within their safe limits, but their combined effect may result in hypoxia.<sup>7</sup> The normal percentage of oxygen in air is 20.9% and the least oxygen content under normal atmospheric conditions is 18 percent, as specified by the American Conference of Government Industrial Hygienists (ACGIH). The Threshold Limit Value (TLV), which is the time weighted average of a gas over an 8-hour period, is 25 parts per million (ppm) for carbon monoxide (Table 1).

The eye, nose and throat irritations experienced from being in the MKT are likely caused from either sulfur dioxide (SO<sub>2</sub>) or from small amounts of formaldehyde (HCHO). Sulfur dioxide is intensely irritating to the eyes and respiratory tract. High concentrations of sulfur dioxide can cause severe breathing difficulties. Sulfur dioxide's irritant properties are due primarily to the rate it forms sulfuric acid on contact with moist mucous membranes in the throat. The effects of exposure to sulfur dioxide may be increased when in combination with specific particulate matter and/or oxidants (e.g. Nitrogen Dioxide (NO<sub>2</sub>)). Formaldehyde is a skin, eye and respiratory tract irritant. However, symptoms of exposure may occur at airborne concentrations below the adopted exposure limit (Table 1). Formaldehyde has also been identified as a possible human

carcinogen. Table 1, shown below, is a listing of the Threshold Limit Values (TLVs) for these gases as specified by the American Conference of Government Industrial Hygienists for 1991-92.

TABLE 1. - ACGIH Threshold Limit Values (TLVs)

<u>Contaminant</u>	<u>TLV (ppm)</u>	
Formaldehyde	.3	Suspect Carcinogen
Carbon Monoxide	25	
Sulfur Dioxide	2	

Of the combustion products mentioned above, formaldehyde was of particular concern because the TLV for formaldehyde before 1991-92 was 3.0 ppm. Previous testing with similar types of equipment indicated the concentration of formaldehyde was below 3.0 ppm. However, with a tenfold decrease in the TLV of formaldehyde, a strong possibility exists for the concentration of formaldehyde within the MKT to exceed 0.3 ppm.

Another concern in cold weather is the high temperature differential between the floor and ceiling within the MKT. The measured temperature difference has been reported to be over 120°F, resulting in personnel often working in their T-shirts, while their feet are cold. This condition causes significant discomfort and inconvenience for personnel working within the MKT. The condition occurs primarily because buoyant warm air from the M-2 burners increases convection from the cold floor surface and because the burners draft enormous amounts of cold air through spaces in the floor of the MKT, leaving very warm air near the ceiling and cold air near the floor. Skirts available for the MKT, which fit from the ground to the floor around the perimeter of the MKT, help reduce the draft and insulate the floor by creating a dead air space beneath the floor. However, the skirts have not been adopted because of the lack of funding.

One last area of concern is the low efficiency of the cooking equipment used within the MKT. At the time the MKT and M-2 burner were developed, fuel economy was not of great concern. Previous testing within the MKT indicated that the efficiency of the cooking equipment ranged from approximately 10 to 20%. So, even small increases in efficiency can result in significant fuel savings.<sup>4</sup> However, possibly more important would be the reduction of the amount of excess heat within the MKT in cold weather conditions.

## OBJECTIVE

The primary objective in developing and testing a ventilation system for the MKT was to reduce the combustion products in cold weather conditions. Secondary objectives were to reduce the temperature difference between the floor and ceiling and improve the efficiency or effectiveness of the cooking equipment. Since the MKT is nonpowered (i.e. uses no electricity) the ventilation system developed had to be nonpowered. The system also needed to be lightweight, inexpensive, durable, safe to use and easy to install.

## APPROACH

### First Approach

The first approach considered for ventilating the combustion products from the MKT was a ventilation system using fans mounted in the roof vents of the MKT and powered by thermoelectric converters mounted on the cooking equipment. A prototype was built by Teledyne Inc., Timonium, MD, that used two 4-watt thermoelectric converters and powered a 10-inch diameter fan. The thermoelectric converters were mounted on the bottom of a 15-gallon stock pot (see Figures 5 and 6).

Testing of the prototype revealed the fan generated approximately 165 cfm. The primary problem with the thermoelectric ventilation system was that it allowed the combustion products to mix with air within the MKT before being drawn out of the kitchen by the fan. It was questionable that the thermoelectric system could provide adequate ventilation. An adequately sized system would be expensive with thermoelectric converters costing approximately \$20/watt. Another drawback was that the equipment, wires, etc. needed to set up the ventilation system would be susceptible to damage from rough handling. Accordingly, work ceased on the thermoelectric ventilation system and work was initiated on a natural draft stack ventilation system, discussed below in the Second Approach.

### Second Approach

The second approach considered for ventilating the combustion products from the MKT were stacks, or chimneys, that captured the combustion products and sent them directly through the roof of the kitchen. The second approach was a passive system that relied on natural draft created from the heat of combustion. Draft is the pressure difference associated with the movement of combustion gases through a chimney.

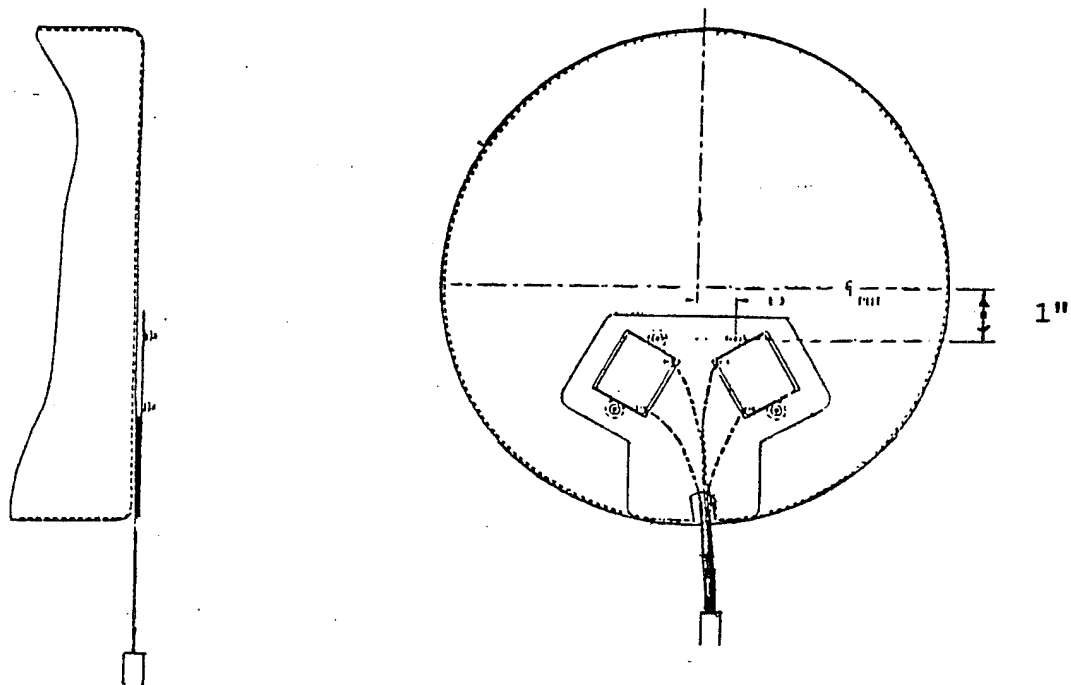
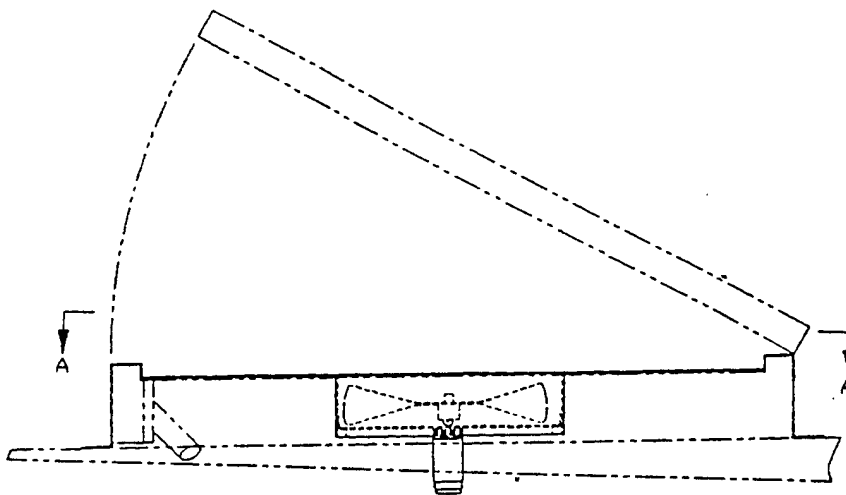
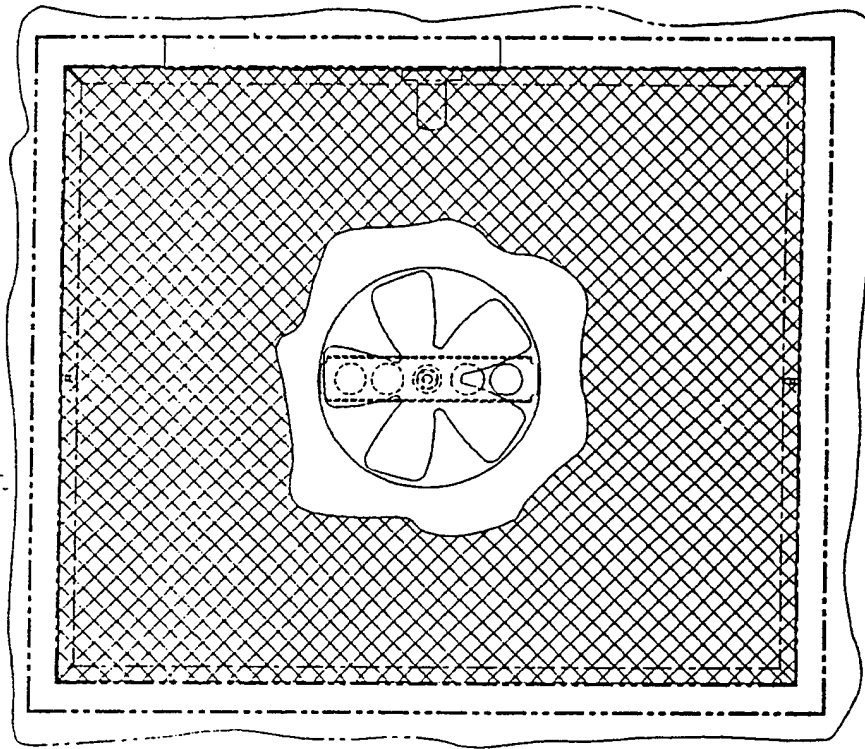

Figure 5. Placement of thermoelectric converters on the bottom of a 15-gallon stock pot.

Section  
A - A  
Rotated 90° CCW



END VIEW

Figure 6. Placement of thermoelectric-powered fan assembly in the Mobile Kitchen Trailer's roof vent.

Natural draft is caused by the difference in density between the combustion gases inside the chimney and the density of an equal volume of air outside the chimney. Natural draft is directly proportional to the height of the chimney and is dependent upon the average temperature of the combustion gases. A natural draft stack ventilation system would take combustion products directly out of the MKT into the outside atmosphere. Two prototype ventilation systems, called "equipment vents", were developed.

The primary objective for the first set of equipment vents was to establish the feasibility of the approach and determine the amount of combustion products removed by the stack ventilation system. The objective of the second set was to improve the design to get better results. An equipment vent was designed for the M-59 range cabinet, grill and griddle. Drawings of the equipment vents were prepared (see Appendix A) and sent to the shop for fabrication. While the equipment vents were fabricated, testing was initiated on the MKT to establish a baseline for the current conditions within the MKT.

#### Baseline for Testing

In establishing a baseline, the number of variables affecting the concentration of the combustion products had to be kept to a minimum. The configuration chosen to accomplish this was to close-up the MKT and shelter it from the wind. The MKT was positioned in the corner of two buildings that sheltered the MKT from the wind in two directions, see Figure 7. For testing the combustion products, three M-2 burners (one for the M-59 range cabinet, grill and griddle) were operated at high, medium and low capacity. To simulate cooking, fifteen-gallon stock pots were filled with water and placed above each burner. The stock pots acted as heat sinks for the heat produced by the burners.

The primary variable considered to affect the concentration of the combustion products within the MKT was the ambient temperature. Several tests were completed during the winter months at various ambient temperatures. Once a baseline was established, the first set of equipment vents was installed and tested at similar ambient conditions to decide if a significant reduction in the combustion products occurred. The results from the baseline were also used to find a general trend of the effect of the ambient condition on the concentration of the combustion products.



Figure 7. MKT's location for testing.

### INSTALLATION PROCEDURE

#### Installation of Equipment Vents

To begin configuring the MKT for testing, the original roof vents on the MKT were secured to allow room for the new roof vents, see Figure 8. The new roof vents were placed on top of the MKT, by going inside the MKT and sliding them through the rectangular hole for the original roof vents. Figure 9 is a picture taken inside the MKT, showing the new roof vents. The new roof vents' sleeves were sealed with duct tape for conducting the baseline testing.

The M-59 range cabinet, griddle and grill on the outside ends of the center aisle were the positions chosen for the M-2 burners and the equipment vents for testing. The equipment vents were installed by positioning them (cover for the M-59 range cabinet, the cowl and the griddle riser) below the sleeves in the new roof vents. Stove pipe cut to the proper length was slid over the sleeve in new roof vents and then over the sleeve of each equipment vent. Pictures of the configuration of the M-59 range cabinet and cowl are shown in Figures 10 and 11, respectively.



Figure 8. Permanent roof vent covers on the MKT, tied together for the installation of new roof vent covers.



Figure 9. New roof vent covers viewed from inside of the MKT.

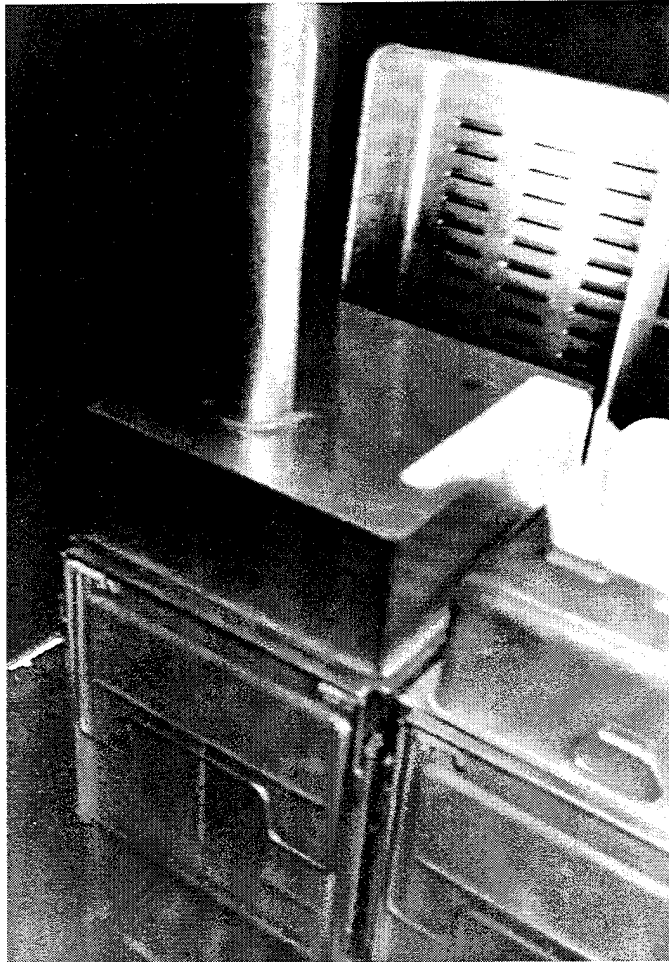

Figure 10. M-59 range cabinet with equipment vent installed.

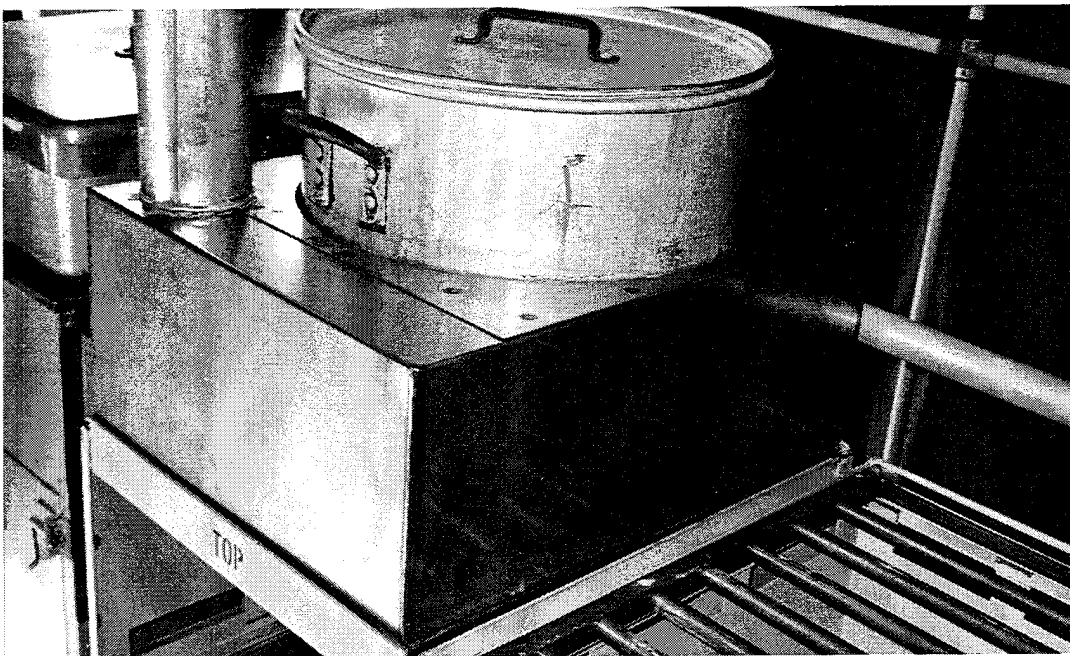

Figure 11. Grill with cowl used for the equipment vents.

A picture of the cowl and stack connecting to a new roof vent is shown in Figure 12.

For the griddle, two 90° bends were added to position the stove pipe from the griddle below the new roof vent. A picture of the griddle riser and stack connecting to the new roof vent is shown in Figure 13.

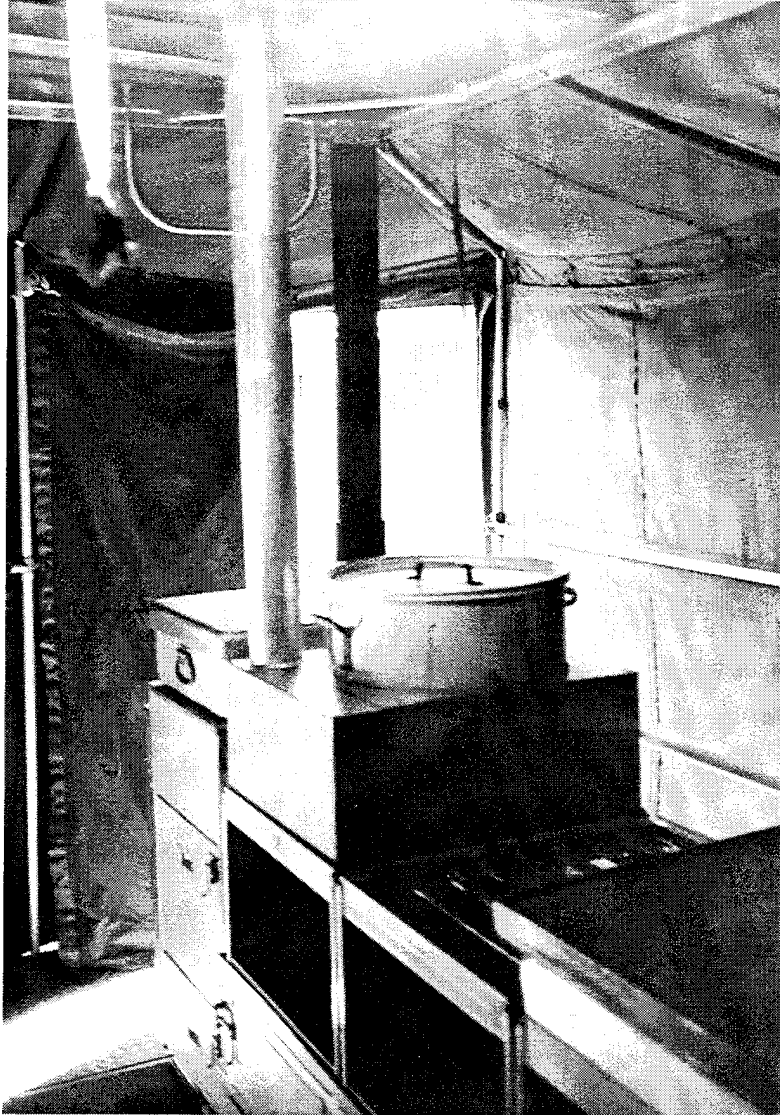

Figure 12. Cowl and stack used for equipment vents.

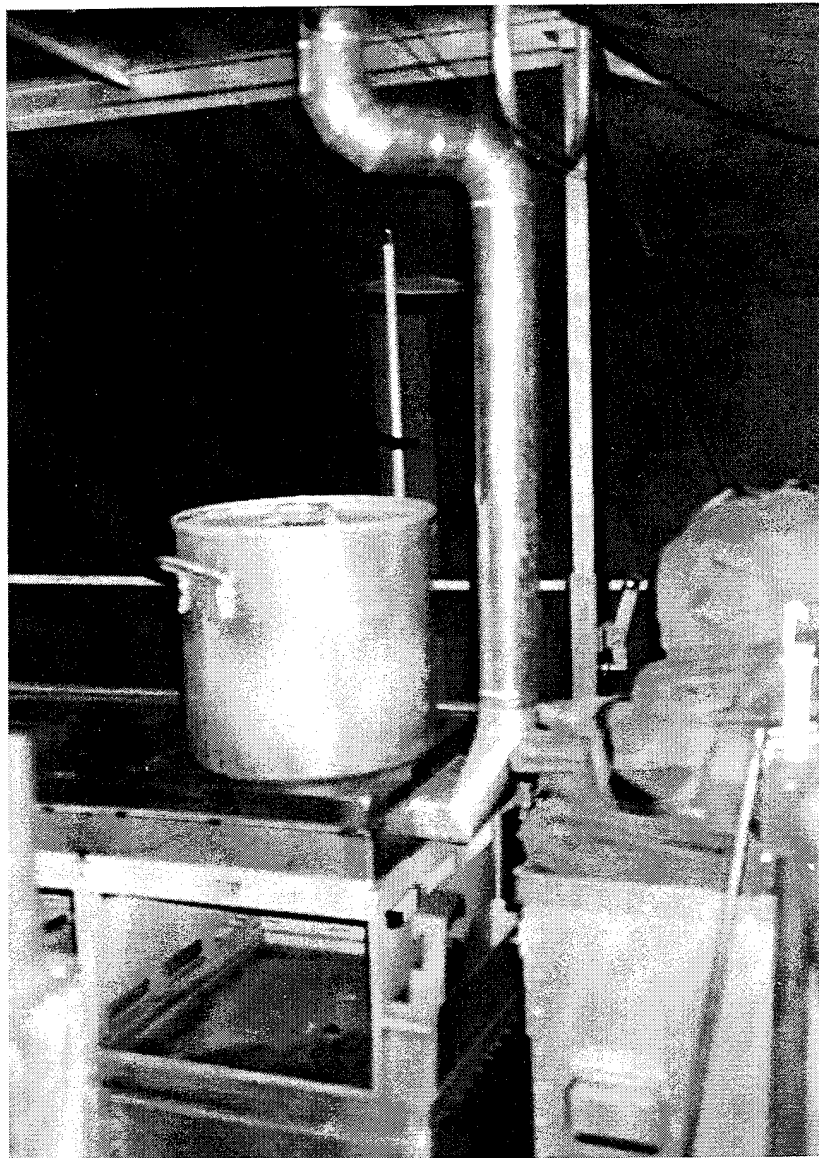

Figure 13. Griddle and stack used for the equipment vent.

### TESTING PROCEDURE

#### Procedure for Setting M-2 and M-3 Outputs

To adjust the M-2 burner to full, mid-range and low output, the following procedure was followed throughout the tests. First, the shutter or air vent on the M-2 burner was adjusted to fully opened, halfway opened, or 1/16" opened, respectively, for full, mid-range and low output. Then the fuel valve on the M-2 burner was adjusted until a sea-blue flame developed.

The M-3 burner has two primary outputs, high and low. High is attained with the vapor valve and air shutter fully open. Low output is attained with the vapor valve control at the low setting while the air shutter is closed, anchoring the flame on the flame holder.

Pots of water were placed above each M-2 burner or M-3 burner throughout the tests. This was done to simulate cooking by creating a similar heat load and to reduce the average temperature in the MKT during testing.

The testing usually continued for 2 to 3 hours, depending primarily on the length of time required for the MKT to reach a steady state condition. Once conditions stabilized, the testing was continued for approximately 1 hour to collect adequate data for comparing the vent versus nonvent.

#### Equipment Vent Test Procedure

Before testing was started, a fuel sample (gasoline) was sent out to be analyzed to determine the percent of sulfur by weight in the fuel. This test was performed so that sulfur in the fuel could be correlated with sulfur in the air. Three M-2 burners were used to test the equipment vents. The M-2 burner beneath the grill was operated at full capacity, the M-2 burner beneath the griddle at low capacity and the M-2 burner inside the M-59 range cabinet at mid-range capacity.

The air quality was measured with a Neotronics Exotox 75 gas monitor. The Exotox 75 gas monitor measured the percent Oxygen (O<sub>2</sub>) and Relative Humidity (RH). The Exotox 75 was also used to measure the parts per million (ppm) of Carbon Monoxide (CO) and Sulfur Dioxide (SO<sub>2</sub>). The Exotox 75 sampling hose was placed in the center of the MKT, five feet from the floor. The data was logged every minute into an electronic data logger included with the unit. When the testing was completed the data was downloaded through a system data interface to an IBM compatible computer. Appendix B contains a complete list of the test equipment used and calibrations performed.

The tests were performed with the MKT completely closed to simulate the worst case scenario (i.e. cold weather). One test was performed at each of the following ambient temperatures: 25°F, 30°F, 35°F and two at 45°F ambient temperature. The tests were performed initially without the equipment vents installed (nonvent) to form a baseline from which the equipment vents could be compared. After the baseline was established, the equipment vents were installed and ready for testing at the previous ambient temperatures (25°F, 30°F etc.). However, due to mild weather conditions the equipment vents were only tested at the 45°F ambient temperature. Two tests were completed at this temperature.

## INITIAL TEST RESULTS

Results of the percent sulfur in the fuel are shown in Table 2, alongside the military allowed percentages. Sulfur dioxide readings recorded during testing were low and sporadic and were not considered reliable. The poor results were thought to be due to interference from Nitrogen compounds (NOx). Therefore, a chance exists for problems with sulfur dioxide in the MKT.

TABLE 2. - Sulphur Content of Fuels<sup>3</sup> (% by weight)

Fuel	Allowed	Actual
Commercial Gasoline Summer	.031 Typ	
Winter	.026 Typ	
MIL-G-3056 MoGas	<u>.10 Max</u>	.06
Commercial Diesel	.28 Typ	.21
VV-F-800 Diesel DF-A	.25 Typ	
DF-1	.50 Typ	
DF-2	<u>.50 Max</u>	.5

Figure 14 is a compilation of the baseline data from a range of ambient temperatures (25°F, 30°F, 35°F and 45°F) for the nonvent configuration within the MKT. These results were used to form the baseline to determine the benefit of adding the equipment vents. The figures also illustrate the general trend of conditions within the MKT depending on ambient temperatures. Wind speed and other test variables were approximately constant.

The carbon monoxide graph shows the effect ambient temperature has on the concentration of carbon monoxide within the MKT. The results from this figure suggest that at colder ambient temperatures significantly more air exchanges occur, resulting in lower concentrations of carbon monoxide.

The oxygen level graph shows the effect the ambient temperature has on the percentage of oxygen within the MKT. All of the ambient temperature test results eventually stabilized at approximately 19.0%, except for 45°F/Test 1. However, initially the 25°F and the 45°F/Test 1 ambient temperatures result dropped significantly before stabilizing at approximately 19.0%. The drop of the percentage of oxygen at the 25°F and 45°F/Test 1 ambient temperatures in the beginning of the tests, were likely a result of a delay in the heated air drafting out of the MKT. This phenomena is similar to starting a fireplace, where the chimney needs to be heated before the combustion products begin to draft up and out of the chimney, with the MKT functioning as a chimney.

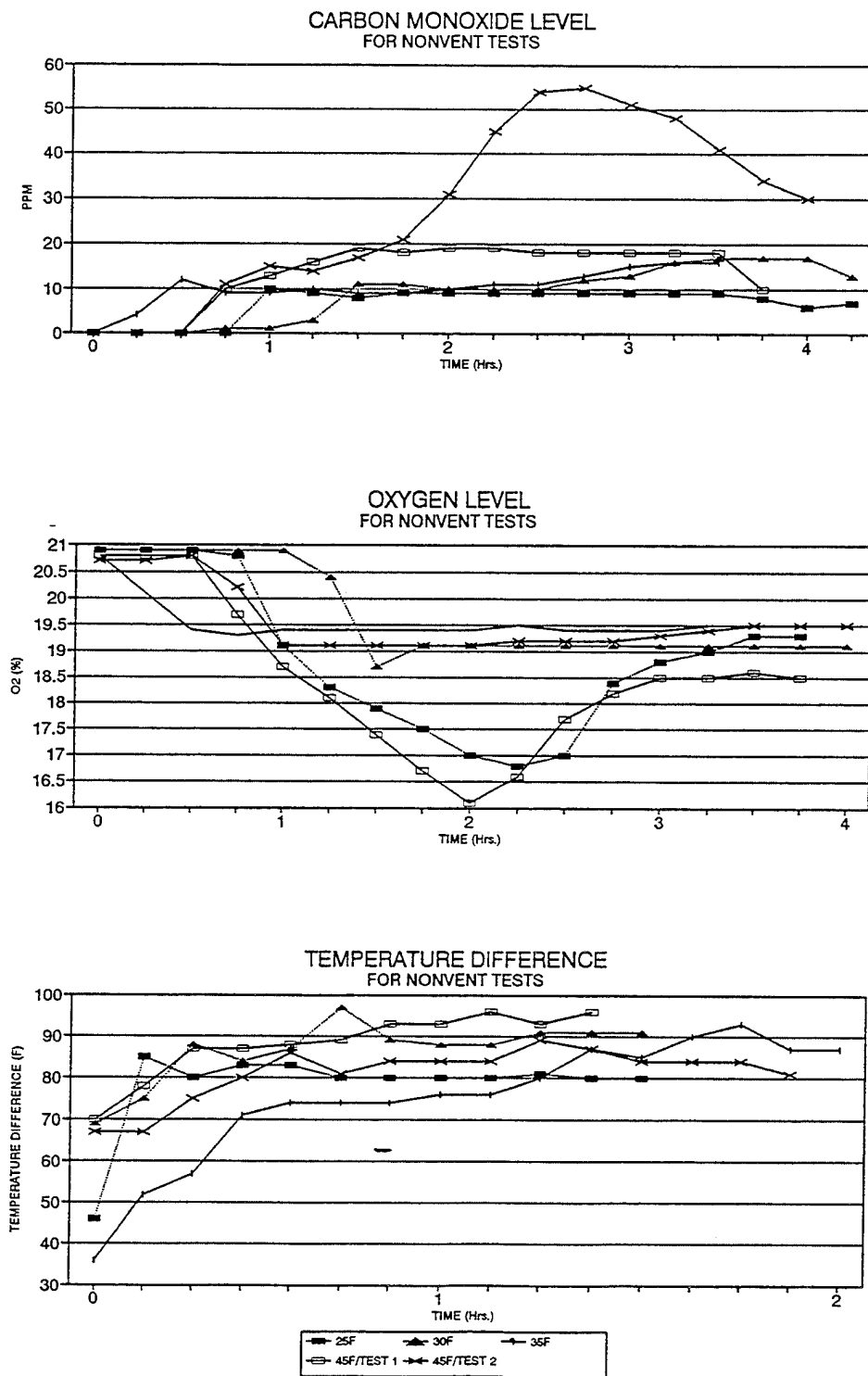

Figure 14. Gas concentrations and temperature difference within the Mobile Kitchen Trailer when using three M-2 burners at various ambient temperatures.

The temperature difference shows the effect the ambient temperature has on the temperature difference between the 1 ft. and 5 ft. distances from the floor in the center of the MKT. All of the ambient temperature test results in this figure eventually stabilized at approximately 85°F, except for test 1 at the 45°F ambient temperature. These results confirm the extreme temperature gradient from floor to ceiling experienced by the personnel working within the MKT.

#### Equipment Vent Results

With the equipment vents installed, two separate tests done on different days were conducted at an ambient temperature of 45°F. The two nonvented tests at 45°F were done on another two separate days. The results of the four tests are shown in Figures 15 and 16. The carbon monoxide graphs in Figures 15 and 16 illustrate the reduction in the concentration of the carbon monoxide within the MKT with the equipment vents installed. In the nonvent configuration, the carbon monoxide concentration overall ranged from 0 to 55 ppm in the two tests completed for the nonvent configuration. However, the concentration of carbon monoxide in the nonvent tests appeared to stabilize at approximately 18 ppm. The results for the nonvent configuration were not similar at the end of test 1 and 2, in test 2 the concentration of carbon monoxide became substantially greater, exceeding the TLV for carbon monoxide (25 ppm). In the vented configuration in the two figures, the carbon monoxide concentration ranged from 0 to 8 ppm, the concentration stabilized at approximately 3 ppm. The results from the vented configuration were similar for test 1 and 2. The figures suggest that the carbon monoxide decreased by at least 15 ppm with equipment vents installed.

The oxygen level graph in Figures 15 and 16 show an increase of the percent oxygen within the MKT with the equipment vents installed. In the nonvent configuration the percent oxygen ranged from 20.9% (atmospheric) to 16%. The oxygen stabilized on average at approximately 18.8%. The results of the two tests for the nonvent configuration were different again. In the beginning of test 1 the percent oxygen significantly dropped, going below the TLV for oxygen (18.0%) before stabilizing at approximately 18.6% oxygen. In the vented configuration, the percent of oxygen ranged from 20.9% to 19.8% oxygen. It stabilized on average at approximately 20.0%. The results from the vented configuration were again similar for tests 1 and 2. The data shows that the percent oxygen increased by approximately 9% (test 1) and 4% (test 2) with the equipment vents installed.

The temperature difference in Figures 15 and 16 shows the reduction of the temperature difference between the 1 ft. and 5 ft. distance from the floor within the MKT with the equipment vents installed. In the nonvent configuration, the average

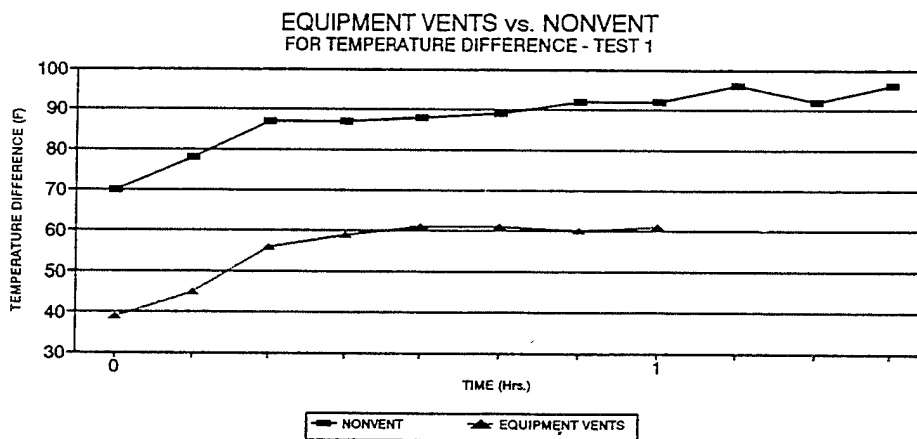
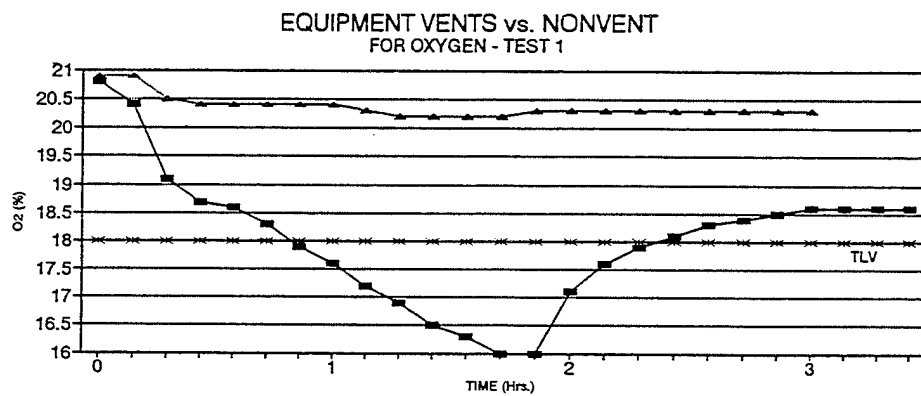
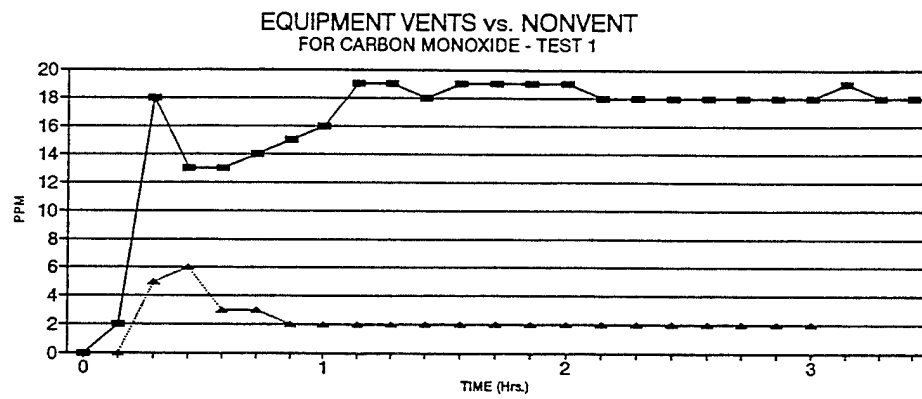

Figure 15. Gas concentrations and temperature difference within the Mobile Kitchen Trailer when using three M-2 burners at an ambient temperature of 45°F (test 1).

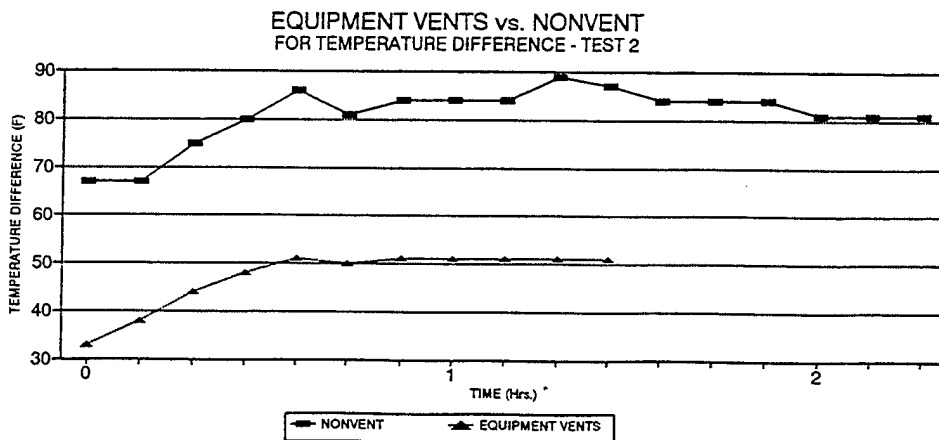
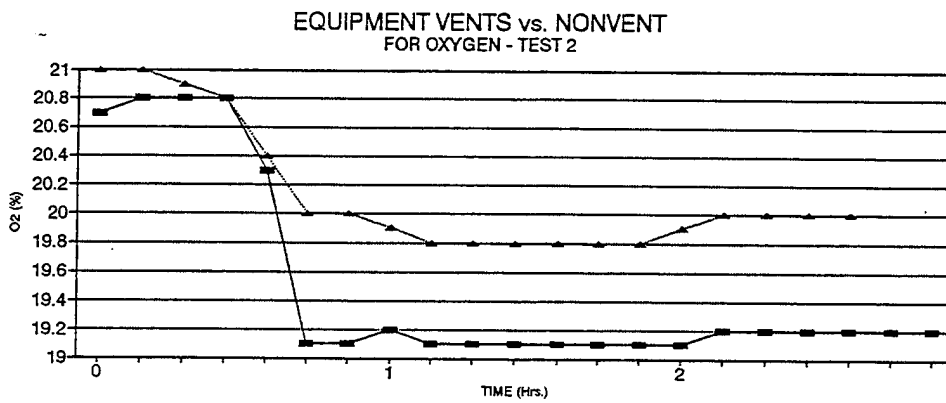
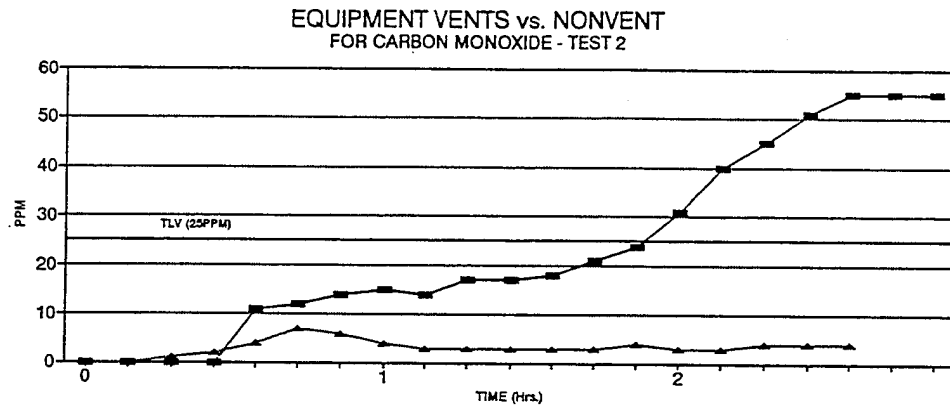

Figure 16. Gas concentrations and temperature difference within the Mobile Kitchen Trailer when using three M-2 burners at an ambient temperature of 45°F (test 2).

temperature difference stabilized at approximately 88°F. In the vented configuration, the average temperature difference stabilized at approximately 55°F. The results from the vented and nonvented configuration are similar for both tests 1 and 2. The Figures show that the temperature difference was reduced by approximately 32°F with the equipment vents installed. (Note: The results for the nonvented configuration begin at a higher initial temperature, because the MKT was tested with the equipment vents first and not given adequate time to cool before initiating testing of the nonvented configuration.)

The results of test 1 and test 2 also seem to suggest that the resulting combustion products within the MKT are more predictable with the equipment vents installed than in the nonvent or baseline configuration. The nonvent configuration may be more sensitive to the environmental condition i.e. wind, amount of direct sun light, etc. for drafting of the combustion products from the MKT. If the MKT in the nonvent configuration is more sensitive to environmental conditions for drafting the combustion products out of the MKT, precise predictions of the resulting combustion products would be difficult and may explain why personnel are not always affected by the combustion products in the MKT in cold weather conditions.

#### IMPROVED EQUIPMENT VENTS

Favorable results from the preliminary equipment vents, led to the development of an improved set of equipment vents. The primary objectives in developing the second set of equipment vents were to: reduce - weight, obtrusiveness and cost; increase - durability and ease of installation. As before, equipment vents were designed specifically for the M-59 range cabinet, grill and griddle. Drawings shown in Appendix A for the designs of the equipment vents were made and sent to the shop for fabrication.

The improved vents were tested using the M-3 multi-fuel burners. Using the M-3 burners would determine if the equipment vents would be required when burning diesel fuel. The baseline results of the M-3 burners also would provide information of how the combustion products of the M-3 burners compared to that of the M-2 burners. To test the performance of the second set of equipment vents, the M-3 burners and M-2 burners were both used. Testing was also conducted to determine if the efficiency or the function of the cooking equipment improved.

It was also decided to test for formaldehyde because of the recent change in classification from a toxic gas (TLV 3ppm) to a suspected carcinogen (TLV 0.3 ppm). Early on in testing problems occurred in trying to use the Neotronics TGM 555 formaldehyde

instrument in the cold, wintery environment. So, testing of formaldehyde was ceased and tried again in a warmer environment. Initially testing was attempted during the summer to get an idea of the concentration of the formaldehyde within the MKT, then repeated in the fall to get conclusive results. Both canvas and screen sides were used on the MKT for this test.

#### Installation of Improved Vents

To begin configuring the MKT for testing, 4-inch diameter holes were cut in the roof of the MKT, in-line with each equipment vent. Chimney collars were then slid into these holes from the roof of the MKT with the plate of the chimney collar resting on the outside of the MKT. The holes in the chimney collar plate were marked on the roof and drilled through the roof of the MKT. Rivets were fit into the drilled holes to attach the chimney collar to the roof of the MKT. Finally, silicon caulking was used to seal the outside edge of the chimney collar plate to prevent water from leaking into the MKT. On the inside of the MKT flexible tubes for the stacks were slid into the chimney collars. Band clamps were not required to hold the flexible stacks in place. However, the flexible stacks may require the band clamps after extended usage. On the outside of the MKT, 4 inch diameter stove pipes, 2 feet long were slid over the chimney collars. Each stove-pipe had a rain-cap to prevent water from running directly into the M-3 burners.

The grill, M-59 range cabinet and the griddle's position that were closest to the outer ends of the center aisle were the positions chosen for the improved vents. The improved vents were installed by positioning each equipment vent (the top cover for the M-59 range cabinet, the cowl and the griddle riser) below each chimney collar. The vents were positioned so that they did not interfere with cooking or serving. The lower ends of the flexible tubes were then cut to length and slid over the stack outlets for each equipment vent. Pictures of the configuration for the M-59 range cabinet and cowl can be shown in Figures 17 and 18, respectively. Another picture of the cowl and stack connecting to a substitute roof vent is shown in Figure 19.

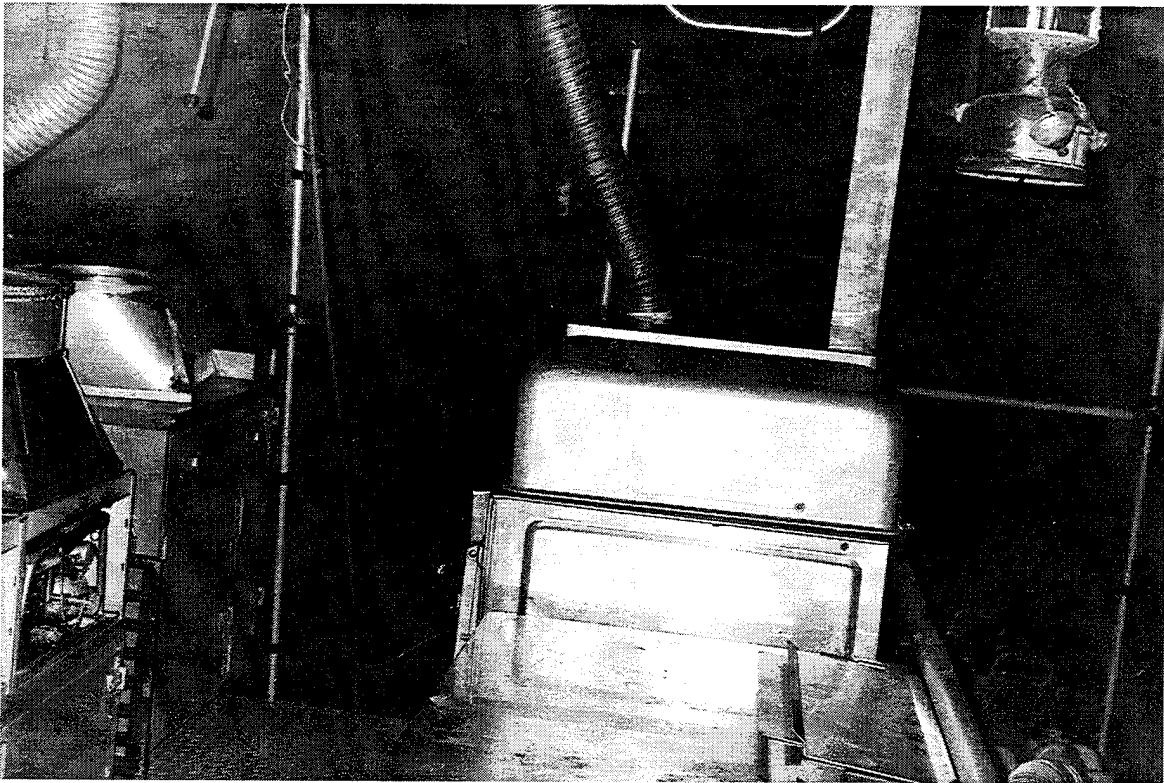

Figure 17. M-59 Range Cabinet with the second equipment vent installed.

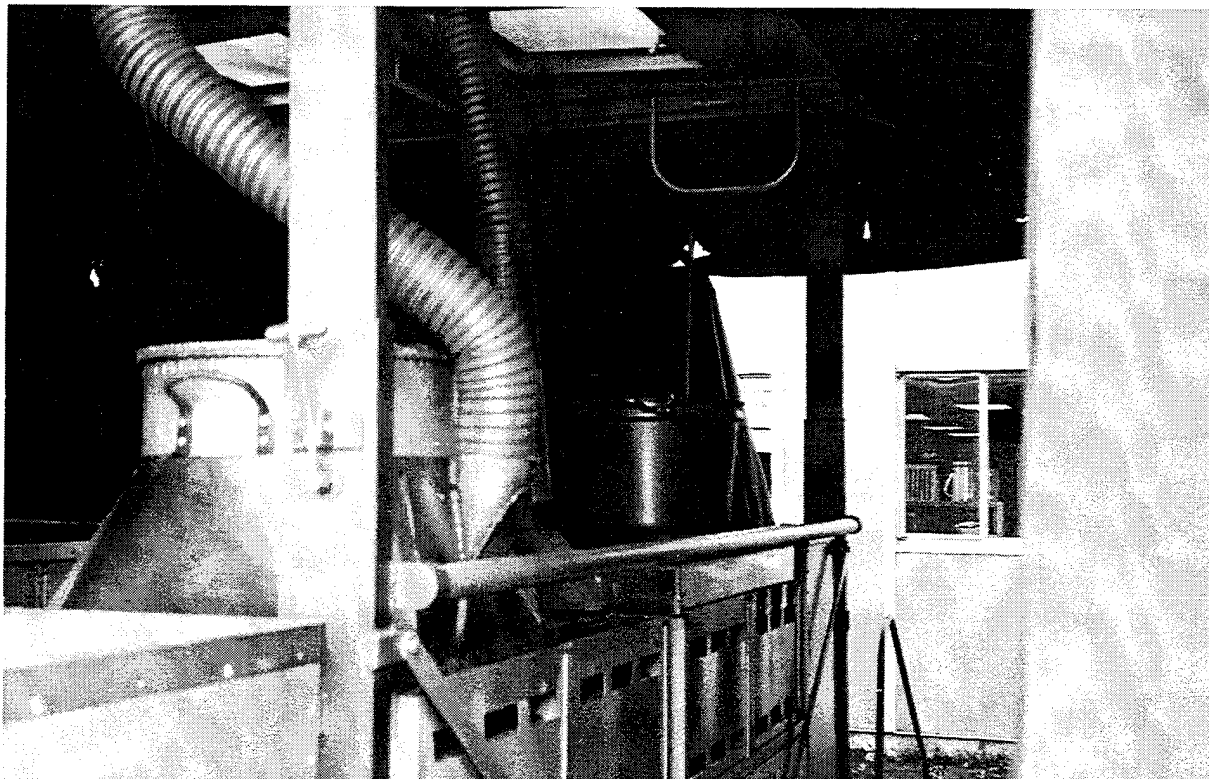

Figure 18. Cowl and stack used for the second set of equipment vents.

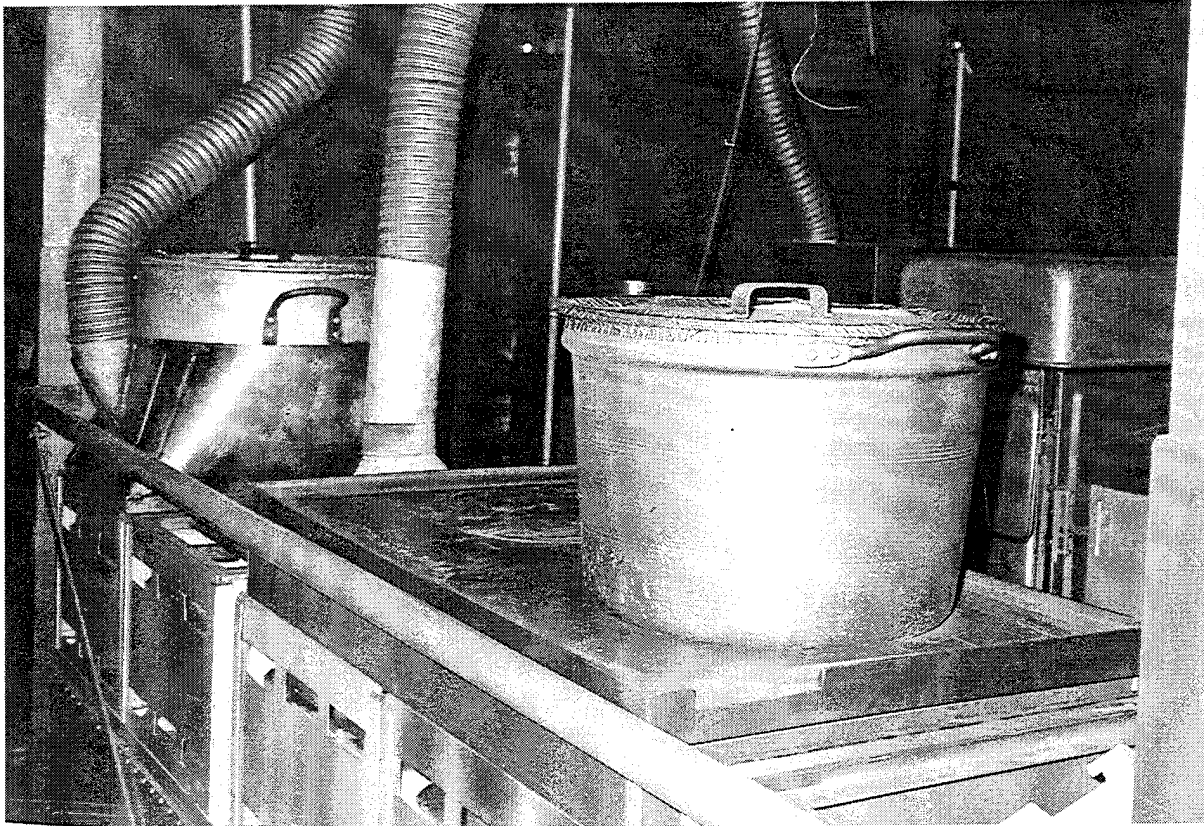

Figure 19. Griddle and stack for the improved equipment vents.

#### Improved Vent Test Procedure

Before testing was started, a fuel sample (#2 heating oil) was analyzed to determine the percent of sulfur by weight in the fuel. For testing the second set of equipment vents, three M-3 burners were used instead of M-2 burners. The M-3 burner beneath the grill was operated at full capacity, the M-3 burner beneath the griddle at low capacity and the M-3 burner inside the M-59 range cabinet at low capacity.

The air quality was measured by the Neotronics Exotox 75 gas monitor. The testing was performed with the MKT completely closed to limit the number of variables that would affect the results and to simulate the worst case scenario (i.e. cold weather). One test was completed at each of the following ambient temperatures: 25°F and 35°F. The tests were performed initially without the vents installed (nonvent) to form a baseline from which the improved vents could be compared. After the baseline was established, the vents were installed and then tests were performed at the same ambient temperature (25°F and 35°F).

## Second Equipment Vents Results

The results for the baseline and the improved vents are given in Figures 20 and 21. The top graph in Figure 20 illustrate the reduction in the concentration of carbon monoxide within the MKT with the improved vents installed. In the nonvent configuration in Figure 20, the carbon monoxide stabilized at approximately 10 ppm. With the vents installed, carbon monoxide was not detected. No values for carbon monoxide are reported in Figure 21 because carbon monoxide did not stabilize in either the nonvent or equipment vent test. The Neotronics sensor for carbon monoxide appeared to malfunction during these tests.

The oxygen graphs of Figures 20 and 21 show an increase in the percentage of oxygen within the MKT with the vents installed. In the nonvent configuration, the percent of oxygen ranged from 20.9% (atmospheric) to 19.8% and stabilized at approximately 19.9% oxygen. In the vented configuration in the two figures, the percent of oxygen ranged from 20.9% (atmospheric) to 20.5% oxygen and stabilized at approximately 20.7% oxygen. The results for the vented and nonvented configuration are very similar for both ambient temperatures (25°F and 35°F). The data shows that the percent oxygen increased by approximately 4% with the improved vents installed.

The temperature difference in Figures 20 and 21 illustrate the reduction of the temperature difference between the 1 ft. and the 5 ft. distance from the floor within the MKT with the improved vents installed. In the nonvent configuration, the average temperature difference stabilized at approximately 125°F. In the vented configuration, the average temperature difference stabilized at approximately 88°F. The results from the vented and nonvented configurations are similar for both ambient temperatures (25°F and 35°F). The data shows that the temperature difference was reduced by approximately 37°F with the vents installed.

## FORMALDEHYDE TESTS

For the formaldehyde testing, a combination of the initial and improved equipment vents had to be used, because the testing took place in a different MKT. For the M-59 range cabinet, the initial equipment vent was used. The improved vents were used for the cowl, griddle riser and stacks. A picture of the M-59 range cabinet configuration is shown in Figure 23. The stacks were attached to the substitute roof vent covers built for the initial equipment vents.

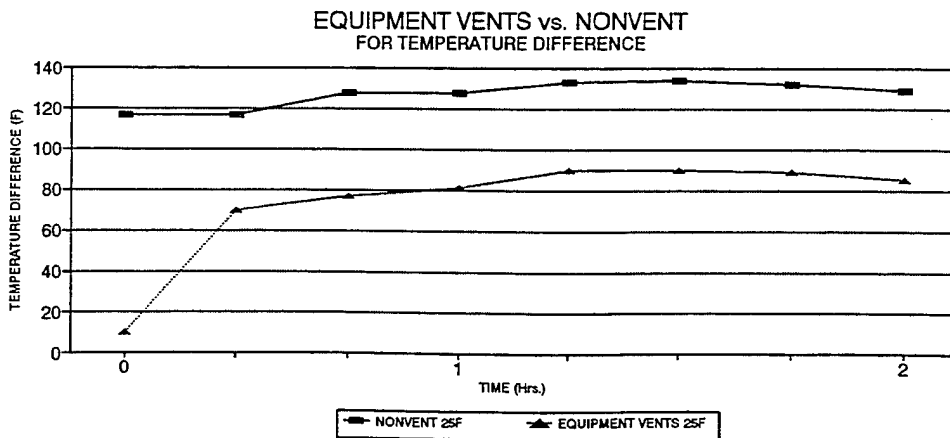
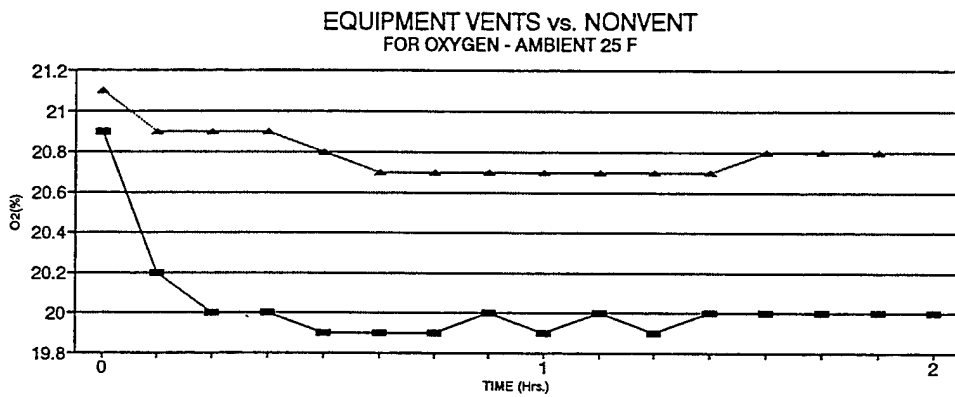
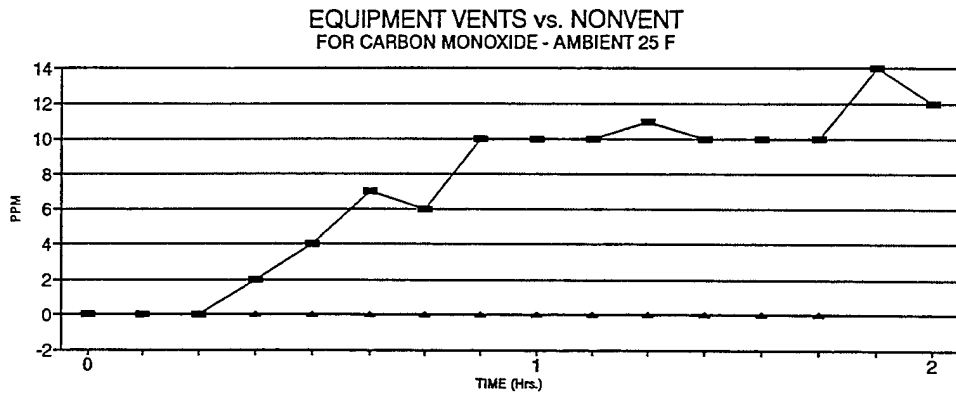

Figure 20. Gas concentrations and temperature difference within the Mobile Kitchen Trailer when three M-3 burners at an ambient temperature of 25°F.

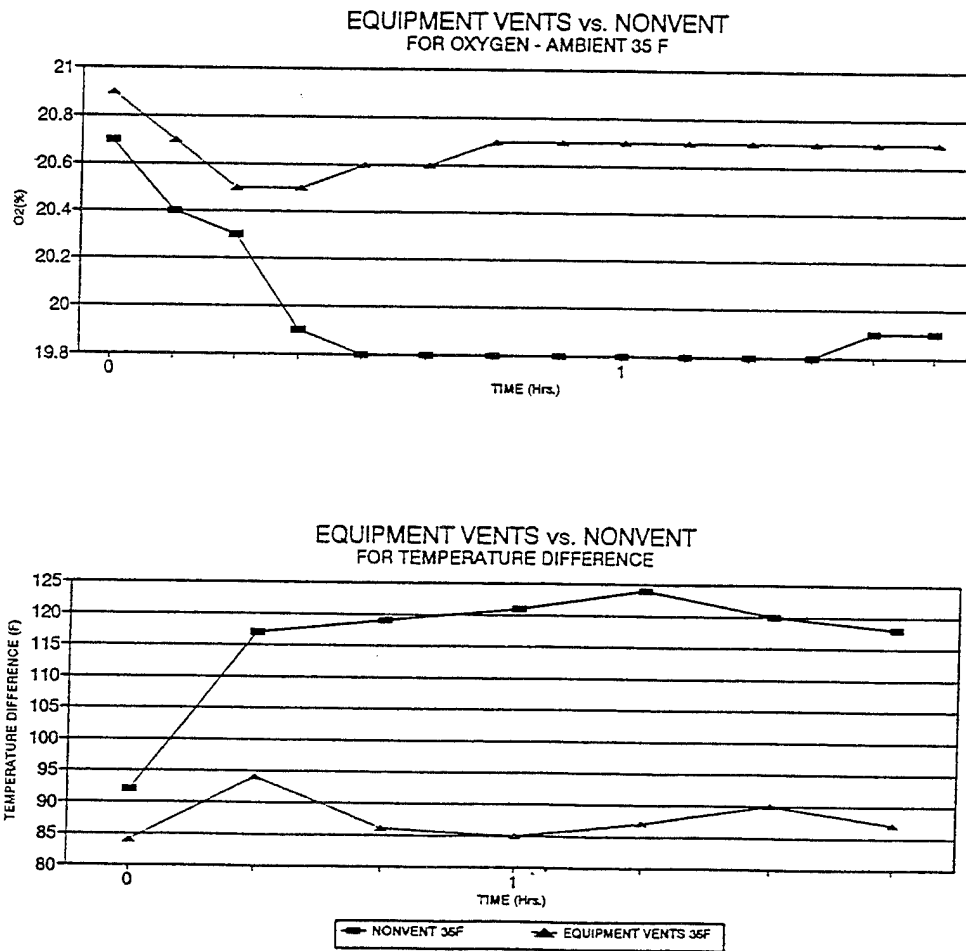

Figure 21. Gas concentrations and temperature difference within the Mobile Kitchen Trailer when using three M-3 burners at an ambient temperature of 35°F.

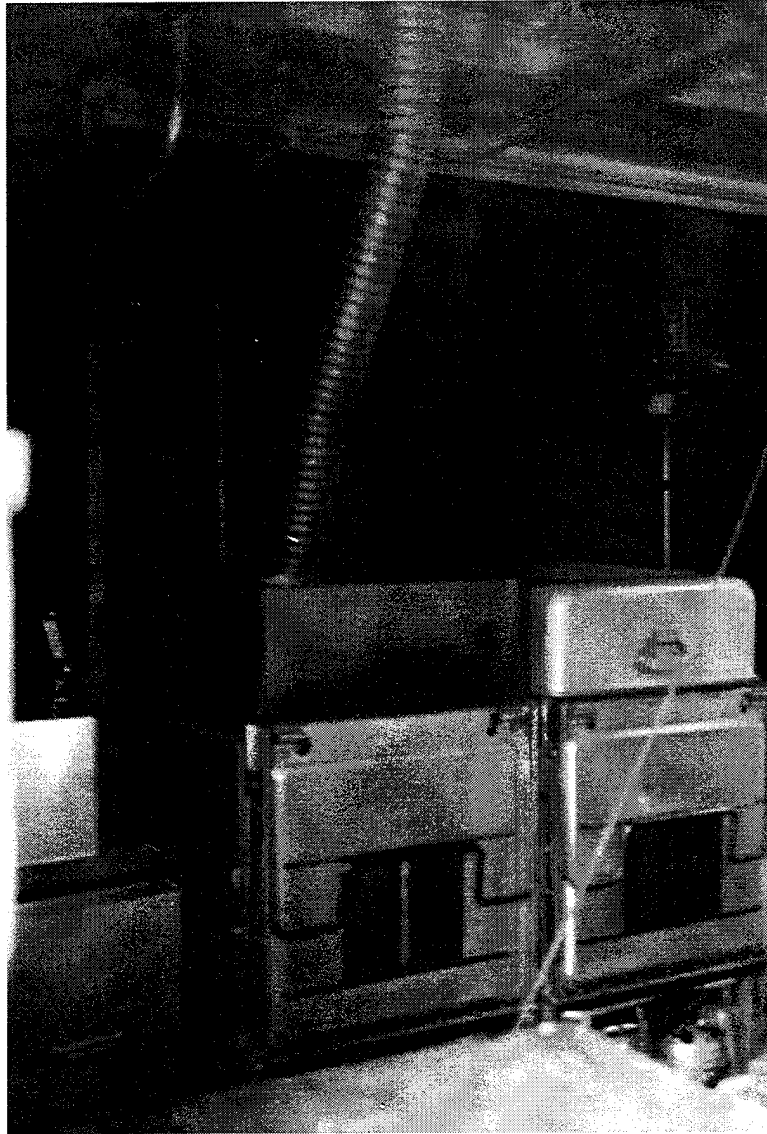

Figure 22. M-59 range cabinet, with the equipment vent used for the formaldehyde testing.

As mentioned previously, a problem occurred in testing the formaldehyde concentration within the MKT during the winter conditions. So testing for the concentration of formaldehyde was continued in the fall with screen sides and five M-2 burners. Besides screen sides on the MKT, canvas sides with three M-2 burners were used again to duplicate the configuration of the previous tests. Formaldehyde was the only combustion gas monitored during these tests.

#### Formaldehyde Testing With Screen Sides

During the fall, five M-2 burners were used in testing a combination of the initial and improved equipment vents with

screens installed on the MKT. The M-2 burner beneath the grill was operated at full capacity, the two M-2 burners beneath the griddle at low capacity and the two M-2 burners inside the two M-59 range cabinets at mid-range capacity.

The formaldehyde concentrations within the MKT were measured by the TGM 555 monitor. The TGM 555 monitors digital readouts are not parts per million, but a percentage of the calibrated scale. The range of the scale for the TGM 555 monitor for these tests was set at 0 to 0.5 ppm of formaldehyde. The TGM 555 monitor was placed outside the MKT, with a 15 ft. sample hose extending into the MKT. Placing the TGM 555 monitor outside of the MKT prevented the monitor from being affected by high temperatures inside the MKT. The TGM 555 sampling hose was placed in the center of the MKT, five feet above the floor to record the formaldehyde readings. The data was logged continuously with the LINEAR Chart Recorder. When the testing was completed, the data points were taken from the chart at 2 minute intervals and entered in a Quattro Pro file. Quattro Pro was used to convert the percentages to parts per million of formaldehyde and develop the graphs to compare vent versus nonvent results. A picture of the TGM 555 monitor and the LINEAR chart recorder is shown in Figure 23.



Figure 23. TGM 555 monitor and LINEAR chart recorder used for testing formaldehyde.

The formaldehyde tests were performed with the roof vents closed and at an ambient temperature of 70°F. The first test was performed without the equipment vents installed to form a baseline from which the first set of equipment vents could be compared. However, the concentration of formaldehyde was so low (0.05 ppm) the equipment vents were not installed, because the concentration of formaldehyde was so low the equipment vents would be of no benefit to the MKT and the results would be hard to compare.

Instead of testing with the equipment vents, the M-2 burners were set to burn with yellow flames to determine the worst concentration of formaldehyde that could possibly occur in the MKT when screen sides were installed. It had been theorized that formaldehyde was an unburned hydrocarbon. By setting the M-2 to display a yellow flame it was thought that a significant amount of formaldehyde would be produced.

#### Formaldehyde Testing With Canvas Sides

During the fall three M-2 burners were used in testing a combination of the initial and improved vents with canvas sides installed on the MKT. The M-2 burner beneath the grill was operated at full capacity, the M-2 burner beneath the griddle at low capacity and the M-2 burner inside the M-59 range cabinet at mid-range capacity. The pots were fitted with a cover and sealed shut with duct tape to reduce the amount of water vapor evaporating into the air. This was necessary for the TGM 555 monitor to function properly.

Testing for the formaldehyde concentrations within the MKT was performed with the roof vents closed. One test was completed at each of the following ambient temperatures: 53°F and 52°F. The tests were performed initially without the vents installed to form a baseline for comparison. After the baseline was established, a combination of the vents was installed.

#### Formaldehyde Test Results

Figure 24 illustrates the concentration of formaldehyde within the MKT with screen sides and with five M-2 burners operating (summer test configuration). In the nonvent configuration the concentration of formaldehyde average 0.05 ppm (precision  $\pm 0.01$  ppm). Even after the M-2 burners were adjusted to produce a yellow flame, the formaldehyde concentration observed was only 0.075 ppm, well below the TLV of formaldehyde. Since the formaldehyde concentration in the MKT with screened sides was very low for the nonvent or baseline configuration, the equipment vents were not added to determine if the formaldehyde concentration would be further reduced within the MKT.

NONVENT WITH SCREEN SIDES  
FOR FORMALDEHYDE - AMBIENT 53F

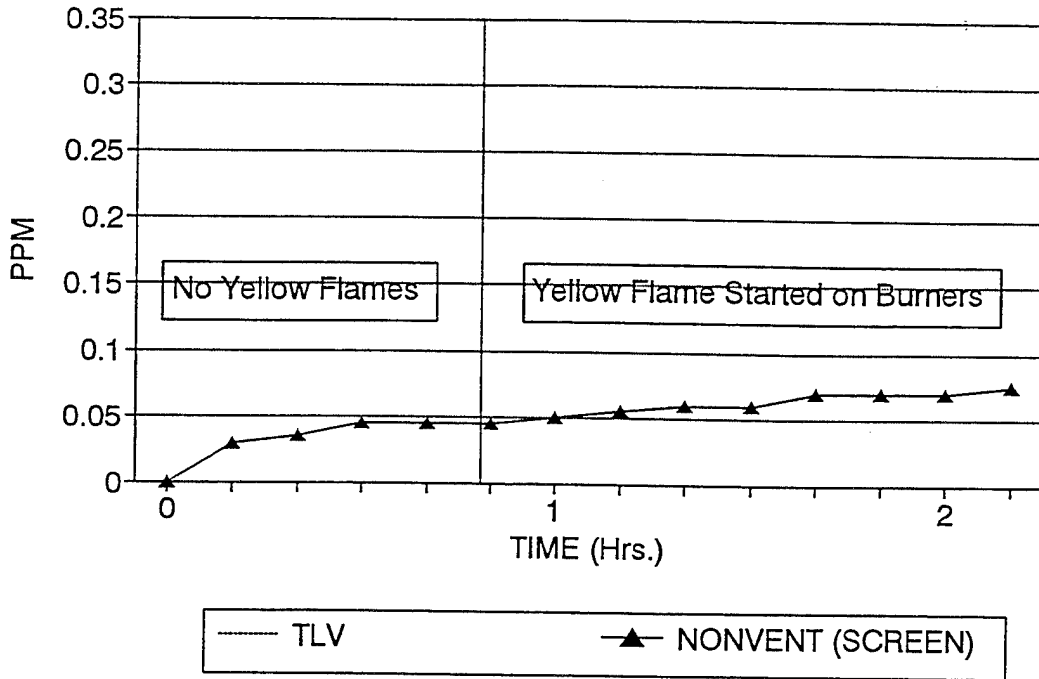

Figure 24. Formaldehyde concentrations within the Mobile Kitchen Trailer when using FIVE M-2 burners, and SCREEN SIDES in the nonvent configuration, at an ambient temperature of 53°F. After 45 minutes the M-2 burners were set to produce a yellow flame to create a worst case condition inside the Mobile Kitchen Trailer when using screen sides. (Note: TLV represents the Threshold Limit Value for formaldehyde and the precision of the data is + or - 0.01 ppm.)

As expected, formaldehyde concentrations in the MKT were much higher when tested with the MKT canvas sides installed. Figure 25 shows the concentration of formaldehyde within the MKT with canvas sides, three M-2 burners and with and without vents. In the nonvent configuration the concentration of formaldehyde stabilized near or above the TLV for formaldehyde. However, with the equipment vents installed the formaldehyde concentration was reduced to approximately 0.05 ppm. In Figure 25 the data for the equipment vents begins at approximately 0.13 ppm because the equipment vents were installed immediately after the test for the nonvent configuration was completed. The MKT was opened while the equipment vents were installed, but the concentration of formaldehyde and the TGM 555 monitor did not completely zero before the test for the equipment vents was initiated.

### PERFORMANCE TEST

To complete the assessment of the equipment vents a series of performance tests were conducted on the equipment to see what effect, if any, the modifications had on cooking performance. The tests were performed on both the grill and the griddle however, the performance of the M-59 range cabinet was not checked.

For testing the performance of the grill and griddle, two M-3 burners and one M-2 burner were operated with the improved vents. The performance of the grill was tested using both M-2 and M-3 burners operating at high capacity. A 15-gallon stock pot filled with 100 lbs. of water was then placed on top of the grill to simulate cooking by creating a similar heat load. The water was heated 130°F without boiling the water (to avoid the heat of vaporization calculation).

#### Performance Test for Grill

The testing of the grill began by establishing a baseline with the M-2 burner. After the baseline was established, the cowl was added to the grill and the test was repeated. A second test was completed with the cowl after adding a half-moon plate below the stack outlet of the cowl. The half-moon plate prevented the combustions products from directly leaving the cowl through the outlet tube and out through the stack. A drawing of the half-moon plate and its position within the cowl is shown in Appendix A (Figure A-11). The results from these tests were kept in a journal before being entered into a Quattro Pro file. Quattro Pro again was used to develop the graphs or figures to compare these three configurations (i.e. nonvent; vented with cowl, vented cowl and half-moon plate). This procedure was repeated for grill using the M-3 burner.

# EQUIPMENT VENT VS. NONVENT WITH CANVAS SIDES

FOR FORMALDEHYDE - AMBIENT 52F & 70F

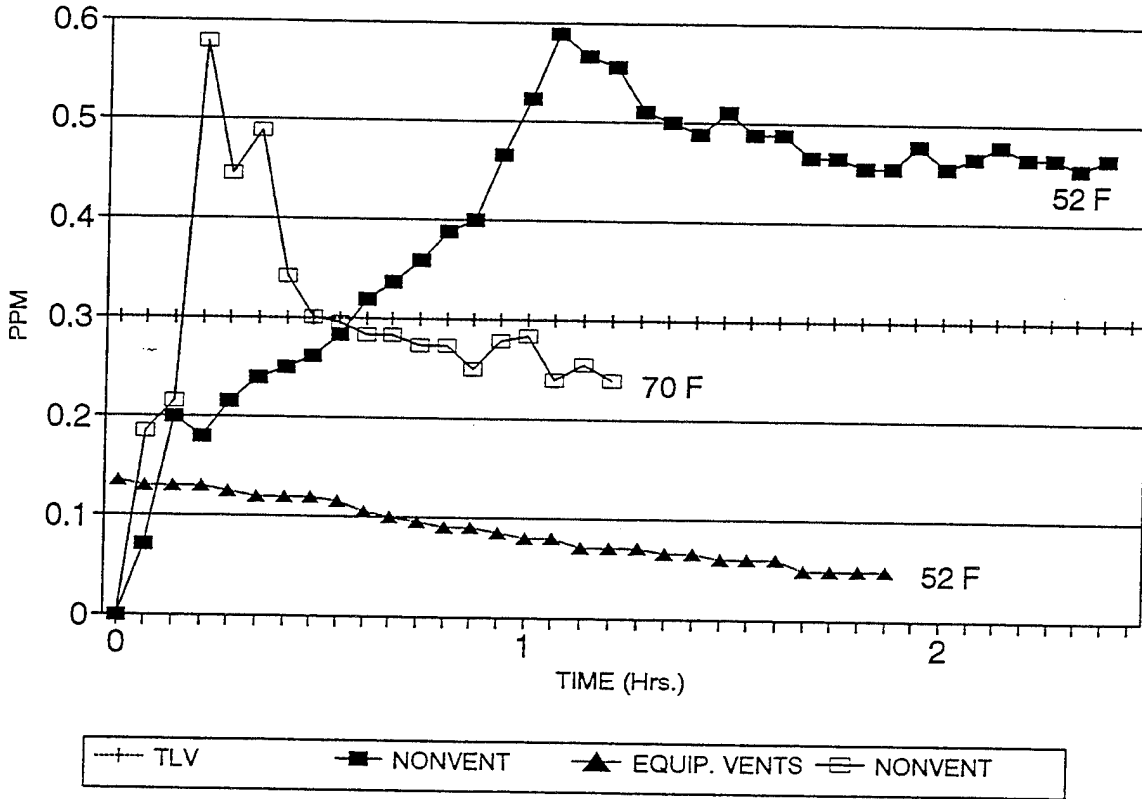

Figure 25. Formaldehyde concentrations within the Mobile Kitchen Trailer when using three M-2 burners in the nonvent and equipment vented configuration at ambient temperatures of 52°F and 70°F. (Note: TLV is the Threshold Limit Value for formaldehyde and the precision of the data is + of - 0.01 ppm.)

The efficiency of the grill was calculated by dividing the energy output by the energy input. The energy output consisted of the temperature change of water (130°F) multiplied by the weight of the water heated. The input consisted of the heat of combustion of the fuel multiplied by the weight of the fuel burned. The Heat of Combustion for gasoline is 20,000 Btu/lb. The Heat of Combustion for diesel is 19,500 Btu/lb. The formula and a sample calculation are shown below.

$$\frac{(\text{temp. change})(\text{weight of water})}{(\text{heat of combustion})(\text{weight of the fuel})} = \text{Efficiency}$$

$$\text{Efficiency} = [(T)(W_w) / (W_f)(H_c)] \times 100 = \%$$

Example:

$$[(130^\circ\text{F})(100 \text{ lbs}) / (2.45 \text{ lbs.})(19,500 \text{ Btu/lb})] \times 100 = \underline{27.2\%}$$

The output for each burner was calculated by multiplying the heat of combustion of the fuel by the weight of the fuel burned and dividing by the time the burner was operated.

$$\text{Capacity} = (\text{heat of combustion})(\text{weight fuel}) / \text{time}$$

$$Q_r = (H_c)(W_f) / t$$

Example:

$$(19,500 \text{ Btu/lb}) (0.75 \text{ lbs}) / (0.25 \text{ hours}) = \underline{58,500 \text{ Btu/hr}}$$

### Performance Test for Griddle

Only the M-3 burners were used in testing the performance of the griddle. The M-3 burners were operated at low capacity for the tests. Fifteen thermocouples were placed on the griddle in the configuration shown in Figure 26. The testing continued until the griddle reached a steady state temperature reading for all the 15 thermocouple locations.

1	4	7	10	13
2	5	8	11	14
3	6	9	12	15

Figure 26. Thermocouple configuration on griddle for performance testing of the griddle.

The testing began by establishing a baseline for the griddle. Two M-3 burners were placed below the griddle without the equipment vent (griddle riser) designed for the griddle. As the fifteen temperatures stabilized, the steady state temperatures were recorded. After the baseline was established, the 3-inch griddle riser was added to the griddle and the test was repeated. The final steady state temperatures for these tests were typed in a Quattro Pro file, graphed and statistically analyzed.

### Performance Testing

Performance testing of the grill was done by measuring the time required to heat 100 lbs. (10.7 gal.) of water to 130°F. Three different configurations (nonvent and two equipment vent configurations) were tested. The water was heated from 70°F to 200°F. The graphs in Figure 27 display the results in two different formats, time and efficiency. The results in the time format show that the equipment vent with the cowl and half-moon plate, reduced the heating time by 30 minutes (32%).

The efficiency graph in Figure 27 illustrates the efficiency of the grill when heating the 100 lbs. (10.7 gal.) of water in the nonvent and two equipment vent configurations. When the grill included the equipment vent with the cowl and half-moon plate, the efficiency of the grill increased from 16.8% to 25.8% or a 54% change.

Figure 28 illustrates the griddle temperatures for the nonvent and equipment vent configuration when heated by two M-3 burners. In the nonvent configuration the average temperature of the griddle was 317°F and the standard deviation was 50°F. When using the equipment vent (griddle riser) the average griddle temperature was 315°F and the standard deviation was reduced to 36°F. In Figure 28 the standard deviations lines for the nonvent and equipment vent are shown based on their average temperature, 316°F. The uniformity of the temperature across the griddle surface was improved by approximately 28% (50°F to 36°F).

Temperature contour plots of the griddle are shown in Figure 29. Each line in the Figure 29 represents a 10°F temperature change. In the figure, steeper temperature gradients are indicated by more lines closer together. A quick glance at Figure 29 reveals the equipment vents have a more uniform temperature distribution than the nonvented configuration, simply based on the number of lines.

# HEATING TIMES FOR WATER ON GRILL

When Using the M-2 Burner

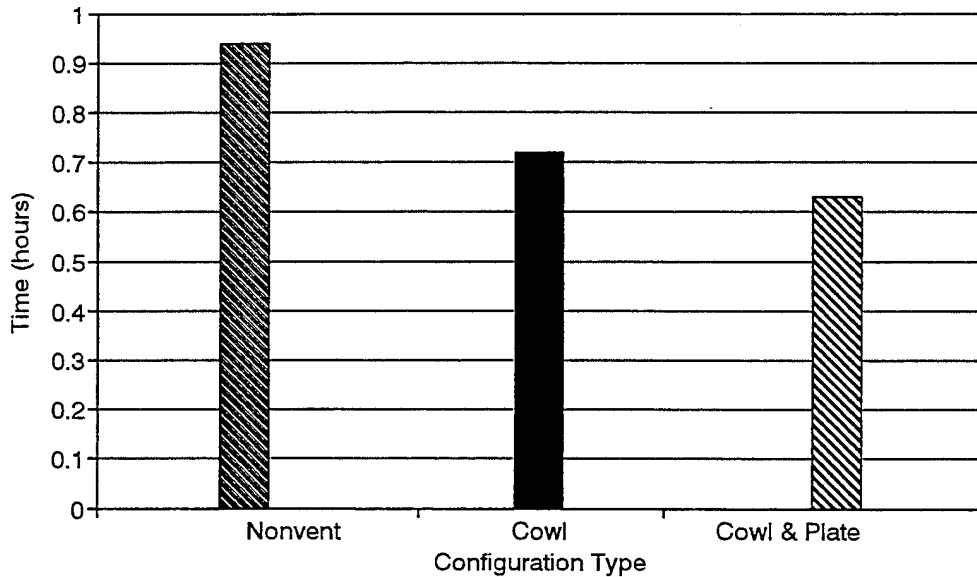

# EFFICIENCY OF THE GRILL

When Using the M-2 Burner

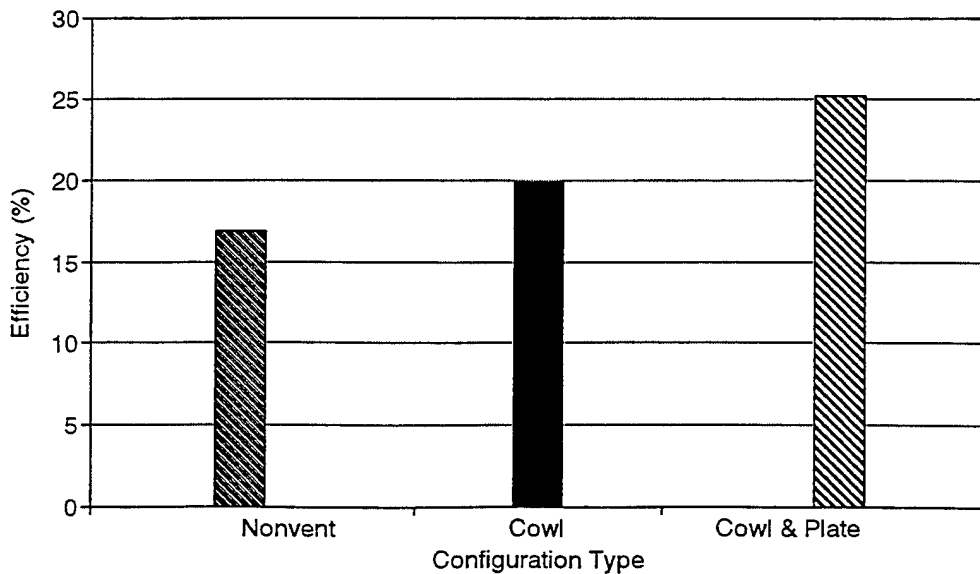

Figure 27. Time and efficiency to heat 100 lbs. of water 130°F on the grill in three different configurations without boiling the water during heating.

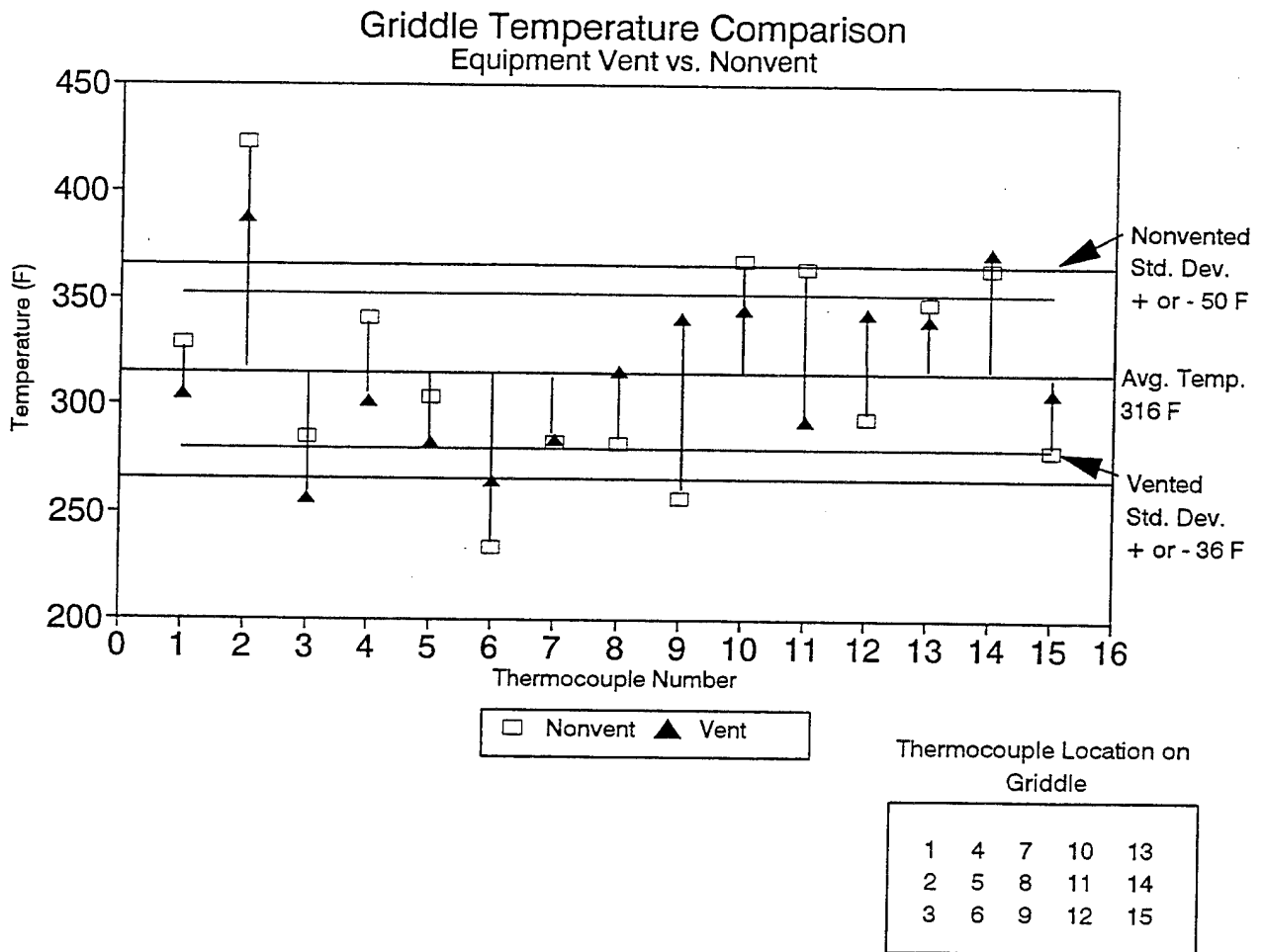
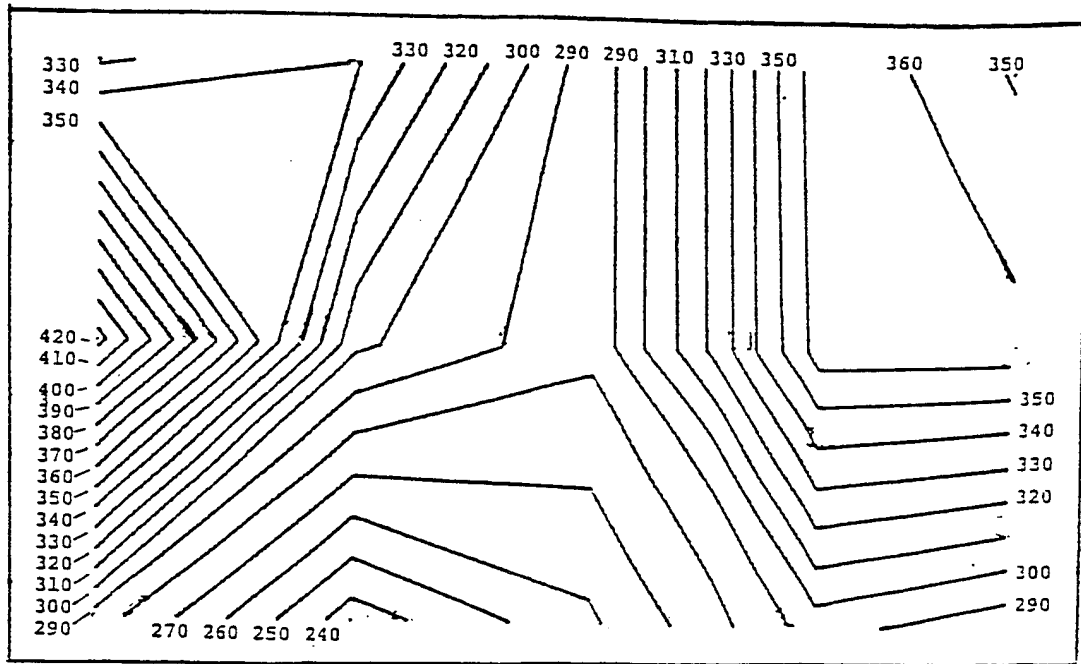
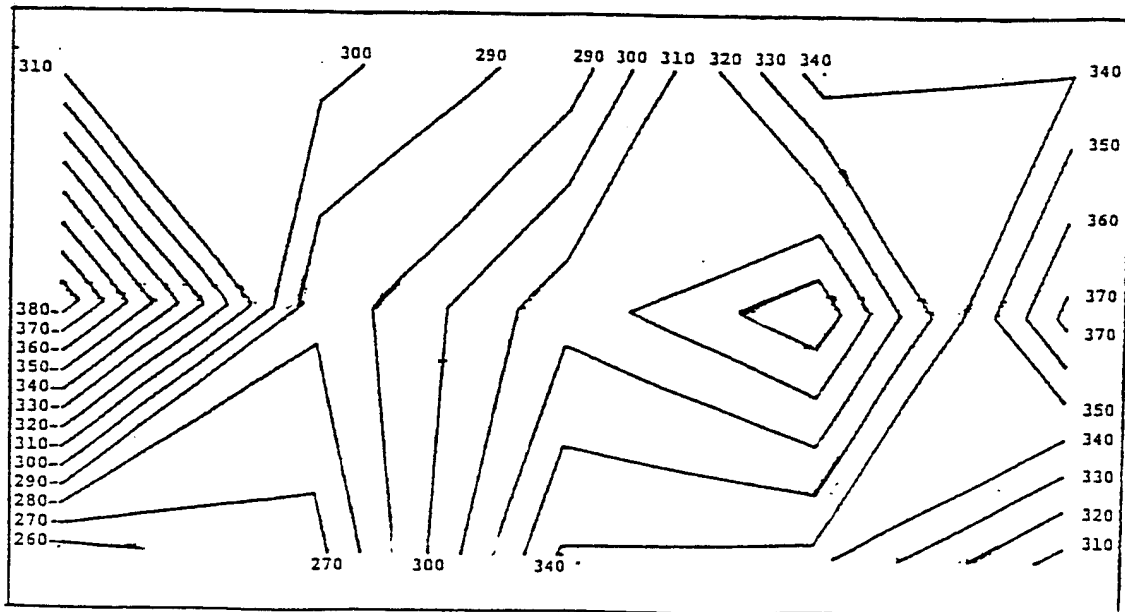

Figure 28. Griddle temperature comparison when using two M-3 burners under the griddle in the nonvent and equipment vented configurations.



Nonvent



Equipment vents

Figure 29. Griddle contour temperature plots for the nonvent and equipment vented configuration.

## DISCUSSION OF RESULTS

Since the design changes between the initial and improved equipment vents were minimal and the nonvent or baseline air quality results for the M-3 burner were generally equal or better than the M-2 burner results, the data was combined for an overall average, shown as the average in Table 3. The overall average for the results give a conservative estimate of the benefit of using the equipment vents.

Table 3 below is a summary of the results from these figures. The values represent relatively steady state test conditions. The average value in the bottom row is the average value for all recorded test conditions.

TABLE 3. - Summary of Results

	NONVENT				EQUIPMENT VENTS			
	CO ppm	O2 %	ΔT °F	HCHO ppm	CO ppm	O2 %	ΔT °F	HCHO ppm
Test 1	18	18.6	95	--	2	20.4	60	--
Test 2	18	19.1	85	--	3	19.9	50	--
25°F	10	20	130	--	0	20.7	90	--
35°F	--	19.9	120	--	--	20.7	88	--
52°F	--	--	--	.46	--	--	--	.05
70°F	--	--	--	.28	--	--	--	--
<u>Average</u>	15.3	19.4	108	.37	1.7	20.4	72	.05

ΔT - Temperature difference between 5 ft. and 1 ft. from the floor in the center of the MKT.

The average concentration of carbon monoxide in the nonvent configuration was 15.3 ppm, or approximately 60% of the TLV (25 ppm). The average concentration of carbon monoxide with the equipment vents installed was 1.7 ppm or approximately 1% of the TLV. Therefore, the equipment vents on average reduced the concentration of carbon monoxide by 13.6 ppm, an 89% reduction. It should be noted that in one of the four tests the carbon monoxide concentration in the nonvent configuration exceeded the TLV of carbon monoxide at the end of the test.

Normal oxygen concentration is 20.9%. The average percent oxygen in the nonvent configuration was 19.4%. The average percent oxygen with the equipment vents installed was 20.4%. Therefore, the equipment vents on average increased the percent oxygen within the MKT by approximately 5%. It should be noted that in one of the four tests the percent oxygen in the nonvent configuration dropped below the TLV of oxygen (18%) before stabilizing at approximately 18.5% oxygen at the end of the test.

In comparing the temperature difference between the 5 ft. and 1 ft. distance from the floor in the center of the MKT, the total output of the burners was a factor. However, the decrease in the temperature difference with the equipment vents installed remained approximately the same. For the first set of equipment vents the nonvent configuration had an average temperature difference of 88°F and the vented configuration had an average temperature difference of 55°F. For the second set of equipment vents the nonvent configuration had an average temperature difference of 125°F and the vented configuration had a average temperature difference of 88°F. The decrease in the temperature difference for the first and second set of equipment vents was respectively 33°F (38%) and 37°F (30%).

The significant decrease (38.8%) in the concentration of carbon monoxide and the significant increase (35%) in the percent of oxygen with the addition of the equipment vents is very important in reducing the chance of hypoxia, since hypoxia can occur when oxygen and carbon monoxide are within their safe limits. From the clinical symptoms experienced from the M-2 burners mentioned in reference 2, hypoxia was the most dangerous and life/mission threatening. The model developed by LTC Carlos F.A. Pinkham in Reference 5 was centered on increasing the amount of oxygen within a confined space when using the M-2 burners. LTC Pinkham suggested that using hooded vents over the M-2 burners, similar to the equipment vents, would likely eliminate the chance of hypoxia.

In the nonvent or baseline configuration when canvas sides were used on the MKT the formaldehyde concentration exceeded or equaled the TLV of formaldehyde (averaged 0.37 ppm). With the equipment vents installed, the concentration of formaldehyde was reduced to 0.05 ppm, a 86% decrease. The results suggest the equipment vents are essential to ensure compliance with the latest TLV set by the American Conference of Government Industrial Hygienists in 1991-1992 for formaldehyde.

In the performance testing of the equipment vents, the grill benefited the most. Heating time could be reduced from approximately an hour to approximately 35 minutes with an increase of efficiency of 8% (17% to 25%). The griddle benefited slightly with the addition of the equipment vent (griddle riser). The standard temperature variation on the griddle was reduced from 50°F to 36°F. A lower average surface temperature was not achieved by raising the griddle surface 3 inches. It's also important to note the M-2 burner was not used in the griddle performance testing. The M-2 burners would likely produce a more uniform griddle temperature, because of the design of the burner head. Therefore, the M-3 burner had the greatest chance to benefit from the griddle riser.

## CONCLUSIONS AND RECOMMENDATIONS

Two approaches were considered for improving the air quality within the MKT. For the first approach, a commonly used method of ventilating a kitchen with an exhaust fan was tried. The fan was powered by a thermoelectric converter. The ventilation rate was insufficient (165 cfm) and this approach was considered ineffective. For the second approach, stacks were connected to each appliance that projected through the roof of the MKT. Natural draft created by the heat from the burners was used to vent combustion products from the MKT.

Two sets of equipment vents were built and tested. The first set of equipment vents determine the approach was feasible and provided positive results for improving the air quality within the MKT. The second set of equipment vents reduced the weight, volume and increased the ease of installation. Testing of the first and second equipment vents led to the following conclusions:

When the MKT was completely closed and three M-2 or M-3 burners were operating at a total output of 100 to 120 thousand Btu/Hr, the equipment vents reduced the carbon monoxide concentration by 89%. The percent oxygen was increased in the MKT by 5%. The temperature difference between 5 ft. and 1 ft. from the floor in the center of the MKT was reduced 30 to 38% depending on the outside temperature. Formaldehyde was reduced by 86% (0.37 to 0.05 ppm).

The results of test 1 and test 2 (Figures 15 & 16) seemed to indicate that the combustion products within the MKT are more predictable with the equipment vents installed than in the nonvent or baseline configuration. It appeared that the nonvent configuration may have been more sensitive to the environmental condition i.e. wind, amount of direct sun light, etc. for drafting of the combustion products from the MKT. If this is true, precise predictions of the resulting combustion products would be difficult and may explain why personnel are not always affected by the combustion products in the MKT in cold weather conditions.

The baseline or nonvent configuration results affirm a need for ventilation in cold weather conditions when either the M-2 or M-3 burners are used within the MKT. The results from the testing indicated that indeed the new formaldehyde TLV is likely to be exceeded when the MKT is completely closed in cold weather conditions. The testing also suggests the possibility of hypoxia occurring because of high carbon monoxide concentration and reduced oxygen levels that occurred twice during testing. Sulfur dioxide was not accurately measured because of interference from nitrogen compounds. For future tests, it's suggested that a new

instrument for measuring sulfur dioxide that has less problems with cross-over interference be purchased.

The equipment vents designed and tested adequately ventilated the MKT to significantly improve the air quality and reduce the possibility of personnel experiencing clinical symptoms such as eye, nose and throat irritations, occasional headache, dizziness and nausea. The equipment vents improved the working environment for personnel within the MKT in cold and temperate weather conditions by reducing the temperature difference between head and foot levels. Finally the equipment vents significantly improved the efficiency of the grill (52%) and the temperature on the griddle was 28% more uniform. The authors of this report highly recommend implementing the ventilation system (equipment vents) proposed in this report for reduction of the combustion products within the MKT.

This document reports research undertaken at the U.S. Army Natick Research, Development and Engineering Center and has been assigned No. NATICK/TR-95/026 in the series of reports approved for publication.

BLANK PAGE

## LIST OF REFERENCES

1. The American Conference of Governmental Industrial Hygienists, 1991. Threshold Limit Values and Biological Exposure Indices for 1991-92, Cincinnati, Ohio.
2. LTC Carlos F. A. Pinkham, 1988. Implications for the Engineering Design of Burner Systems to be Used for Cooking in Confined, Poorly Ventilated Spaces, Analytics, Inc., Tinton Falls, NJ, In Support of Analytics Contract DAAK60-87-0096.
3. Donald W. Pickard, 1992. Safety Assessment Report for Multifuel Burner, SATNC-WEA, USANRDEC, Natick, MA.
4. Dale L. Snyder, 1991. Reliability and Use of the Multifuel Burner (M3) While Conducting Venting Tests, SATNC-WEA, USANRDEC, Natick, MA.
5. LTC Carlos F.A. Pinkham, 1990. A Model of the Partial Pressure of Oxygen in Confined Spaces Containing Operating M2 Burners, SATNC-WAE, USANRDEC, Natick, MA.
6. Food Engineering Laboratory 1984. Mobile Field Kitchen Trailer, SATNC-WAE, USANRDEC, Natick, MA.
7. LTC Carlos F. A. Pinkham, PhD, 1988. Consequences of Cooking with Burners in Confined, Poorly Ventilated Spaces, SATNC-WAE, USANRDEC, Natick MA.
8. Headquarters, Department of the Army, July 1977. Operator, Organizational and Direct Support Maintenance Manual Mobile Field Kitchen Model MKT-75, Technical Manual (TM 10-7360-206-13).

BLANK PAGE

APPENDICES

BLANK PAGE

APPENDIX A  
DESIGN/FABRICATION OF EQUIPMENT VENTS

## DESIGN/FABRICATION PROCEDURE

### Design/Fabrication of First Equipment Vents

Equipment vents were designed for the M59-range cabinet, grill and griddle. For the M-59 range cabinet a new top cover made of stainless steel was fabricated. The new top cover had the same dimensions as the original cover. A 4-inch diameter hole was cut in the cover and a sleeve was attached for a 4-inch diameter stove pipe to slide over. From the sleeve the stove pipe extended upward to the ceiling of the MKT. The pipe was fit into another sleeve in a new roof vent cover made for the MKT. Figure A-1 is a drawing plan for the top cover fabricated for the M-59 range cabinet for the first set of equipment vents.

For the grill a rectangular shaped cowl made of stainless steel was fabricated. The cowl sides followed the perimeter of the grill and then extended upward 8 inches to form a plenum to allow hot combustion gases to heat the sides of the 15-gallon stock pot before being vented through the roof of the MKT. The top of the cowl had a 18 1/4 inch diameter hole cut to fit a 15-gallon stock pot. Another 4-inch diameter hole was cut in the top of the cowl with a sleeve attached for a 4-inch diameter stove pipe to slide over. From the sleeve of the cowl, the stove pipe extended upward to the ceiling of the MKT and fit into another sleeve in a new roof vent cover. Figure A-2 is a drawing plan for the cowl designed and fabricated for the grill for the first set of equipment vents.

For the griddle a rectangular shaped griddle riser made of stainless steel was fabricated. The griddle riser sides followed the perimeter of the griddle to collect the combustion products from both burners beneath the griddle. The griddle riser extended upward 3 inches to form a plenum beneath the griddle to improve the heat distribution from the hot combustion gases across the bottom of the griddle. On the far end of the griddle riser a rectangular hole was cut to fit a 90° air duct adapter for a 4-inch diameter stove pipe. From the 90° air duct adapter the stove pipe extended upward to the ceiling of the MKT and fit into another sleeve in a new roof vent cover. Figure A-3 and A-4 are drawing plans for fabricating the griddle riser designed for the griddle for the first set of equipment vents.

The new roof vent covers made of aluminum were fabricated so holes would not have to be cut into the MKT. The roof vents had the same exterior dimensions as the actual roof vent covers, but had only 1-inch sides. A 4-inch diameter hole was cut in a location of the cover to lineup vertically with each equipment vent sleeve. Each 4-inch hole on the roof vent covers were fitted with a sleeve for the stove pipe stack and extended downward to each equipment vent. Figure A-5 is a drawing plan for the roof vent covers made for the first set of equipment vents.

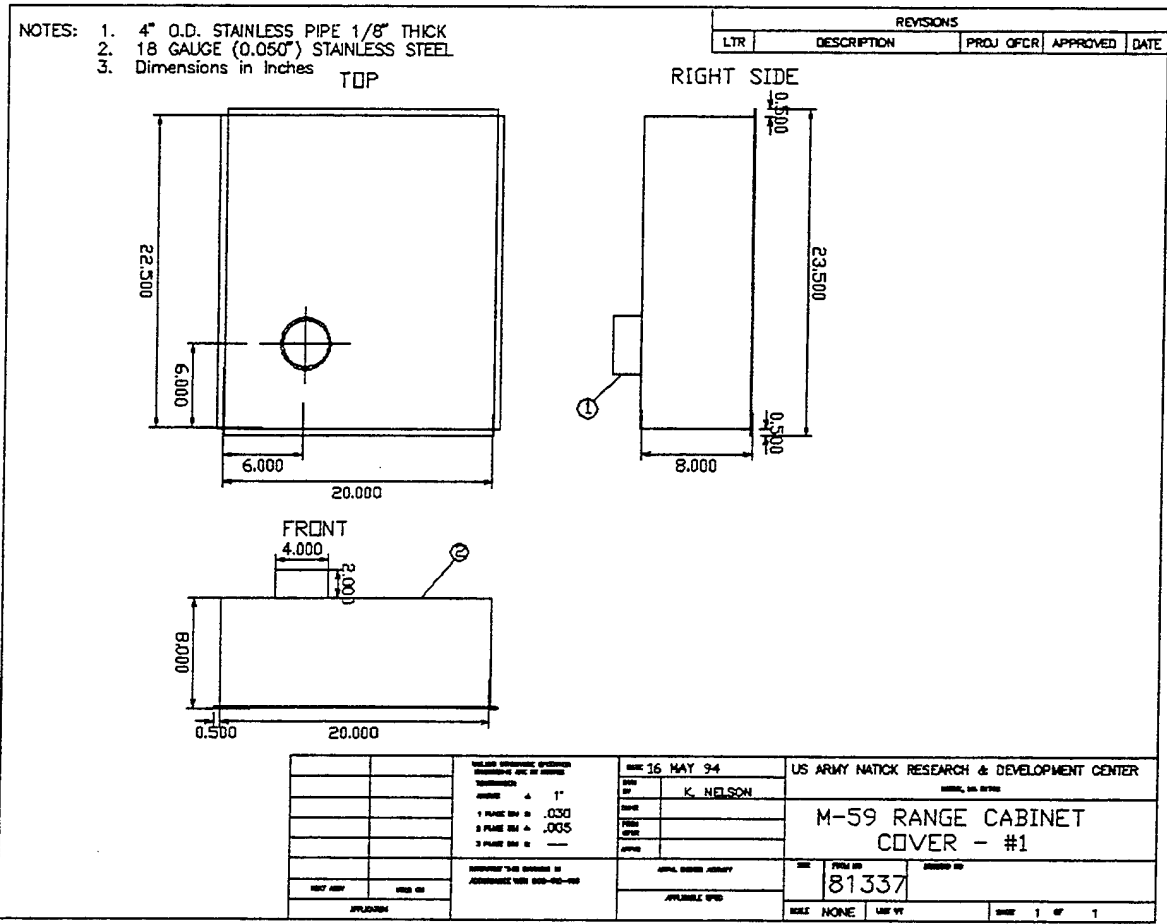

Figure A-1. Drawing plan for the first equipment vent for the M-59 Range Cabinet.





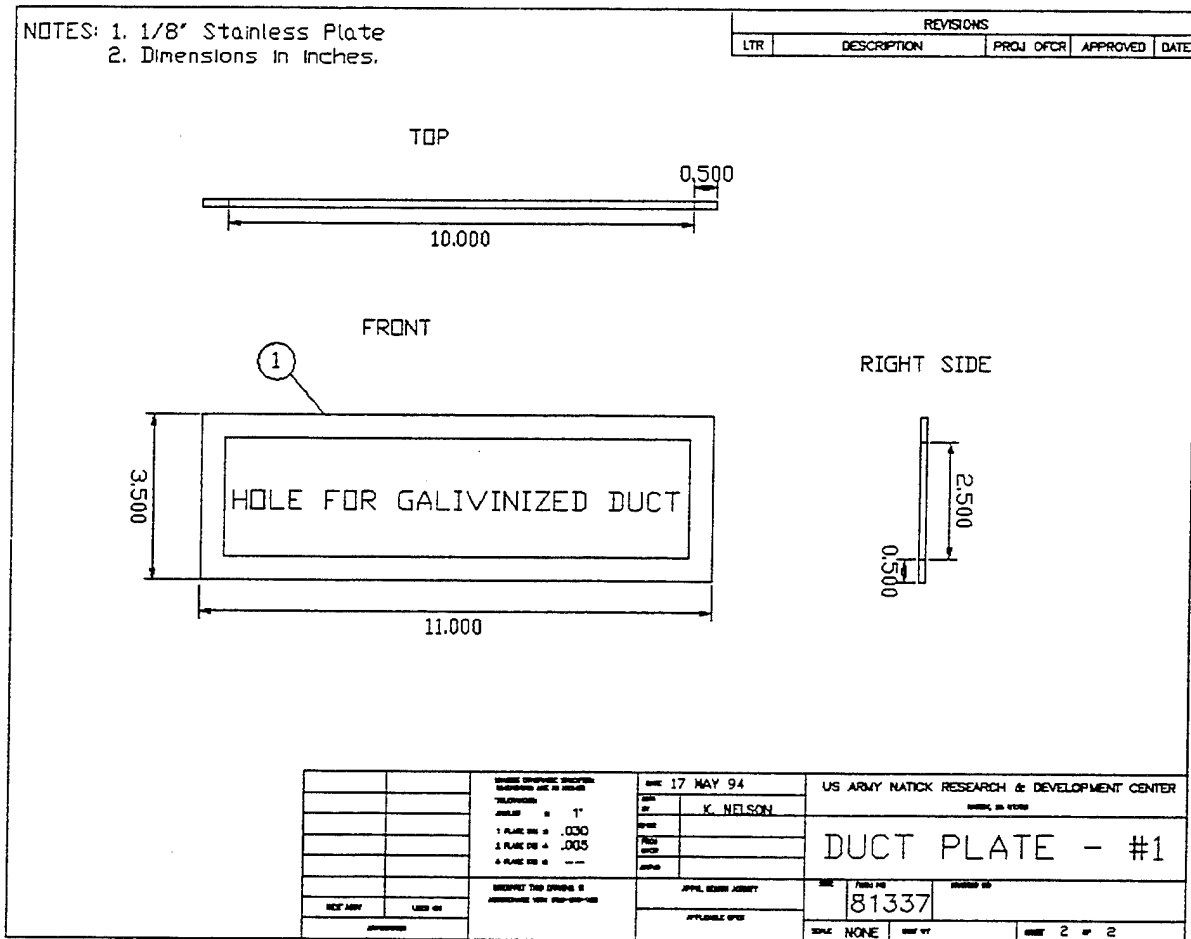

Figure A-4. Drawing plan of Duct Plate to hold galvanized duct on Griddle Riser (figure A-3).

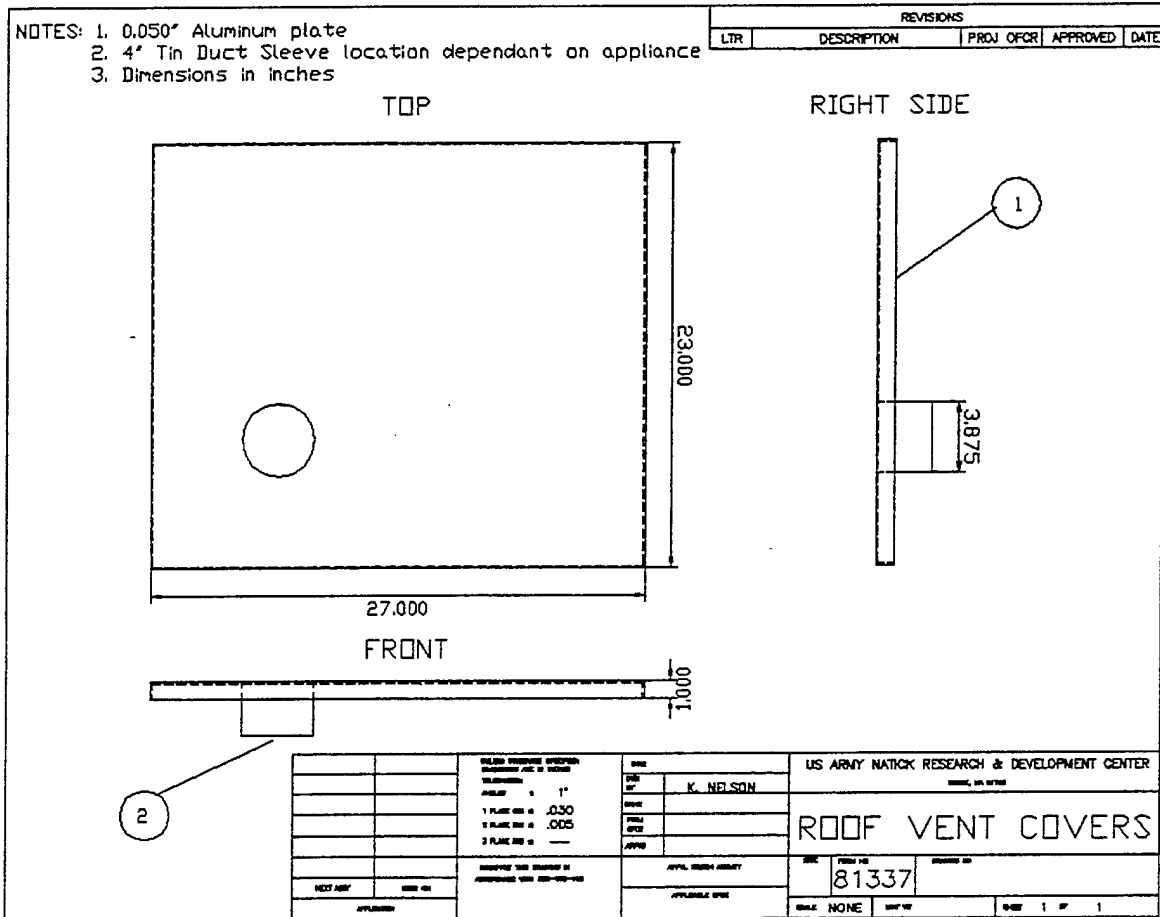

Figure A-5. Drawing plan for substitute Roof Vent Cover to replace Mobile Kitchen Trailer roof vent for testing the equipment vents.

For the stacks, 4-inch diameter stove pipes made of galvanized steel were purchased along with two 90° pipes, five sleeves and a rectangular to round adapter for the griddle's equipment vent. The stove-pipe was cut to fit between each equipment vent and the roof vent covers. Pictures of the first set of equipment vents installed are shown under the "INSTALLATION PROCEDURE" section.

#### Design/Fabrication of Second Equipment Vents

The second set of equipment vents was an improvement over the first. Vents were made for the M-59 range cabinet, grill and griddle. The design of the second set of equipment vents was similar to the first set of equipment vents except the cowl made for the grill and the connections in the ceiling for the stacks were more permanent. For the M-59 range cabinet the top cover slots were flattened shut and a 4-inch diameter hole was cut in the cover. A 4-inch diameter pipe was welded around the hole in the M-59 range cabinet cover to form a stack outlet for the flexible stack to slide over and extend upward the ceiling of the MKT. Figure A-6 is a drawing for the top cover for the M-59 range cabinet.

For the grill, the cowl from the Kitchen Company level (KCL) was used. The cowl sides followed the perimeter of the grill to gather all the combustion products from the burner and allowed the hot combustion air to heat the sides of the 15-gallon pot of water before being vented out through the roof of the MKT. To vent the combustion products from the grill, a hole was cut in the narrow end of the cowl to fit a 4-inch diameter stainless steel-pipe. The 4-inch diameter stainless steel-pipe served as the stack outlet for the flexible stack to slide over. From the stack outlet the flexible stack extends upward through the ceiling of the MKT. The area of the hole cut in the cowl was equal in size to the area of the 4 inch diameter stainless steel-pipe to prevent flow restriction. Figure A-7 is a drawing for the addition of a stack outlet to the KCL cowl.

For the griddle, the same design from the first set of equipment vents was used (Figure A-3), except the griddle riser was made from 1/8" aluminum rather than 1/8" stainless steel. This significantly reduced the weight of the griddle riser without critically reducing the structural strength.

For the roof vents, chimney collars made of aluminum were fabricated and positioned on the roof in-line with each equipment vent. The chimney collars also supported 2 ft. chimney stacks made of stove-pipe on the outside of the MKT to prevent back drafting from occurring. Figure A-9 is a drawing plan for the chimney collars fabricated for the second set of equipment vents.

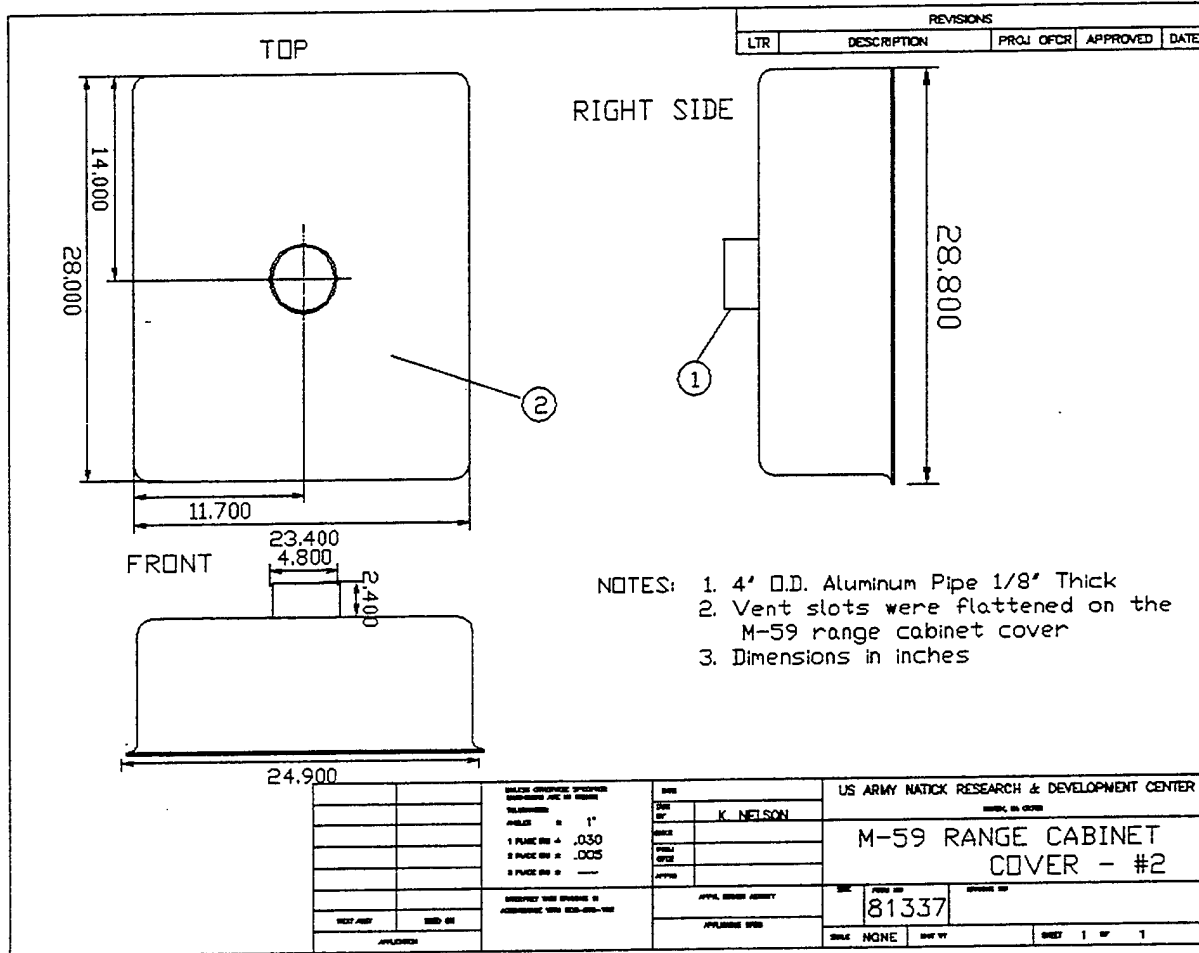

Figure A-6. Drawing of the M-59 Range Cabinet with vent slots closed and 4 inch aluminum pipe added to vent combustion gases.



For the stacks, 4-inch i.d. flexible tubes, able to withstand temperatures up to 600°F were purchased. The flexible tubes were cut to fit between each equipment vent and the chimney collar. A picture of the flexible tubes is shown in Figure A-8.

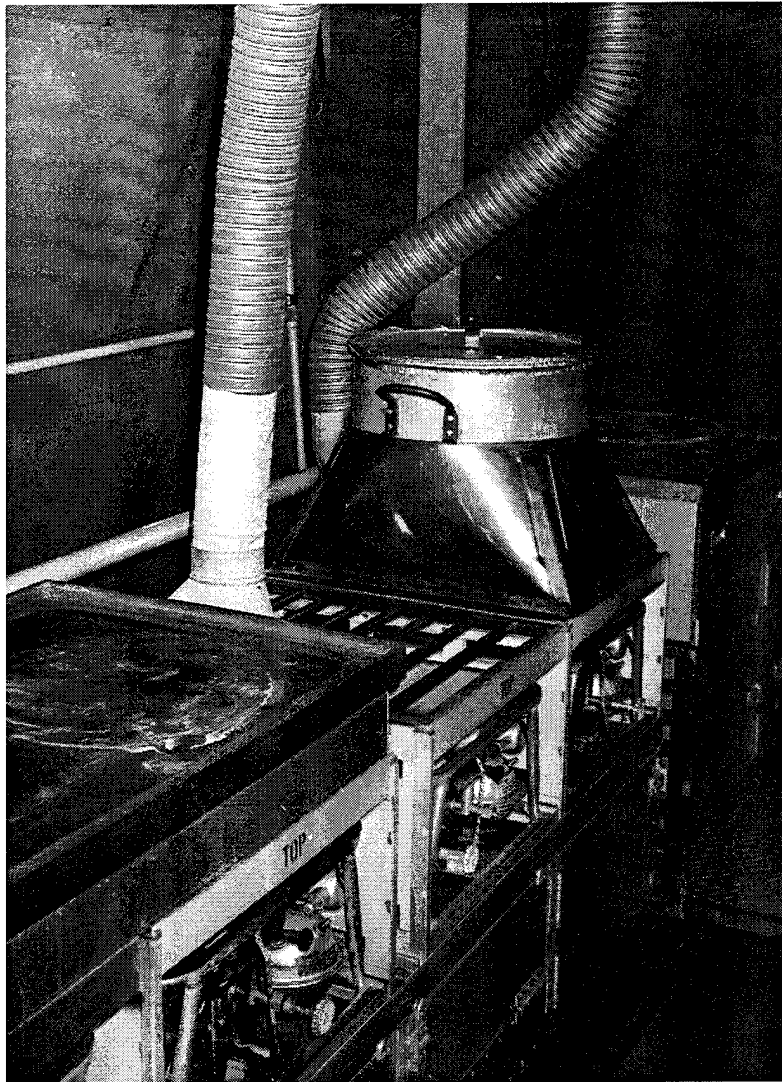

Figure A-8. Flexible tubes used for stacks with the second set of equipment vents.

The roof of the MKT supported 2 ft. sections of 4-inch diameter galvanized stove-pipe fitted with a rain-cap, that was slid over the chimney collars. In transit the stove-pipe and rain-cap would be replaced by a vent cap. The 4-inch stove-pipe and the rain-cap would be stowed inside the MKT. Figure A-10 shows the location of the equipment vents within the MKT.



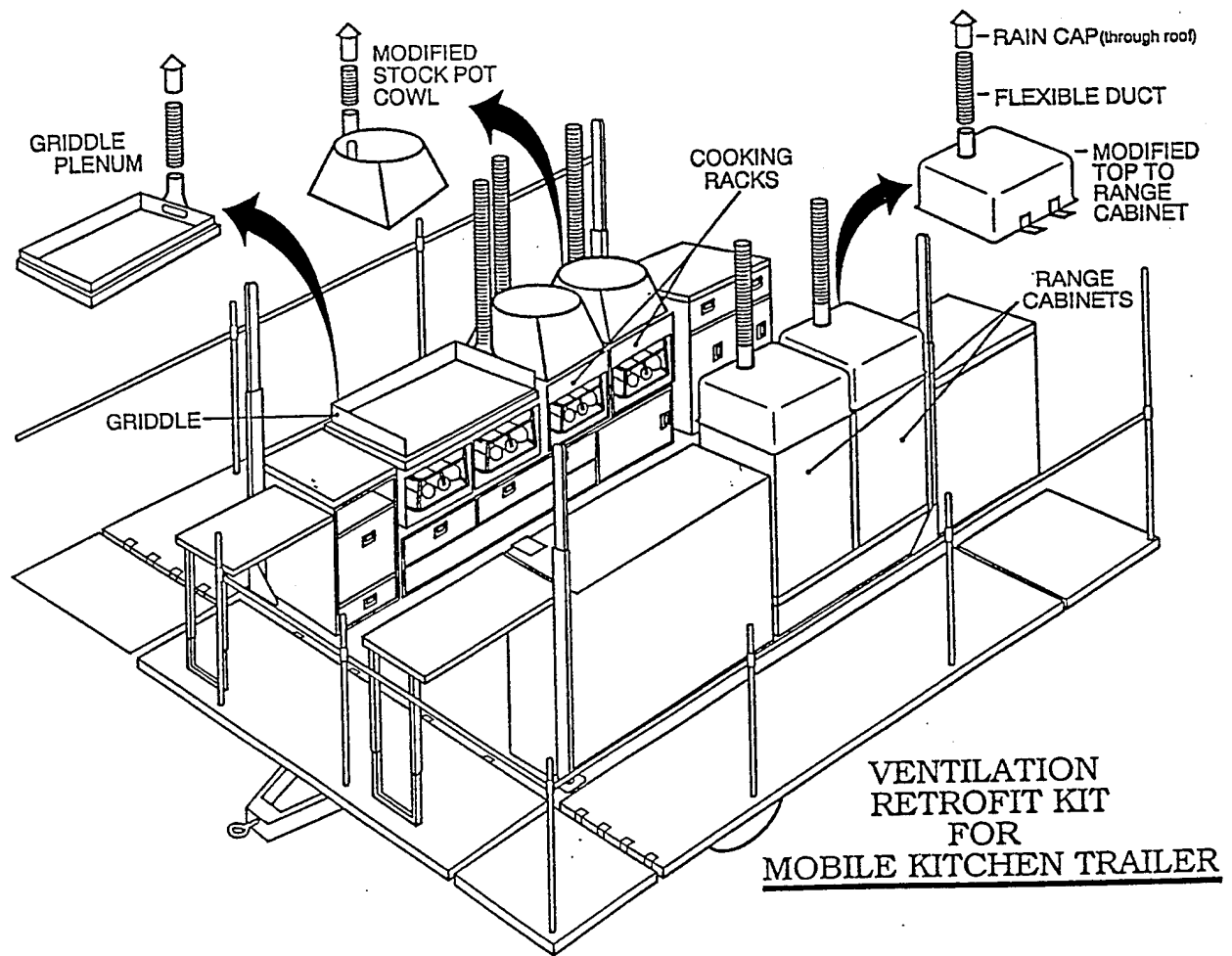

Figure A-10. Perspective view of the ventilation system within the Mobile Kitchen Trailer.

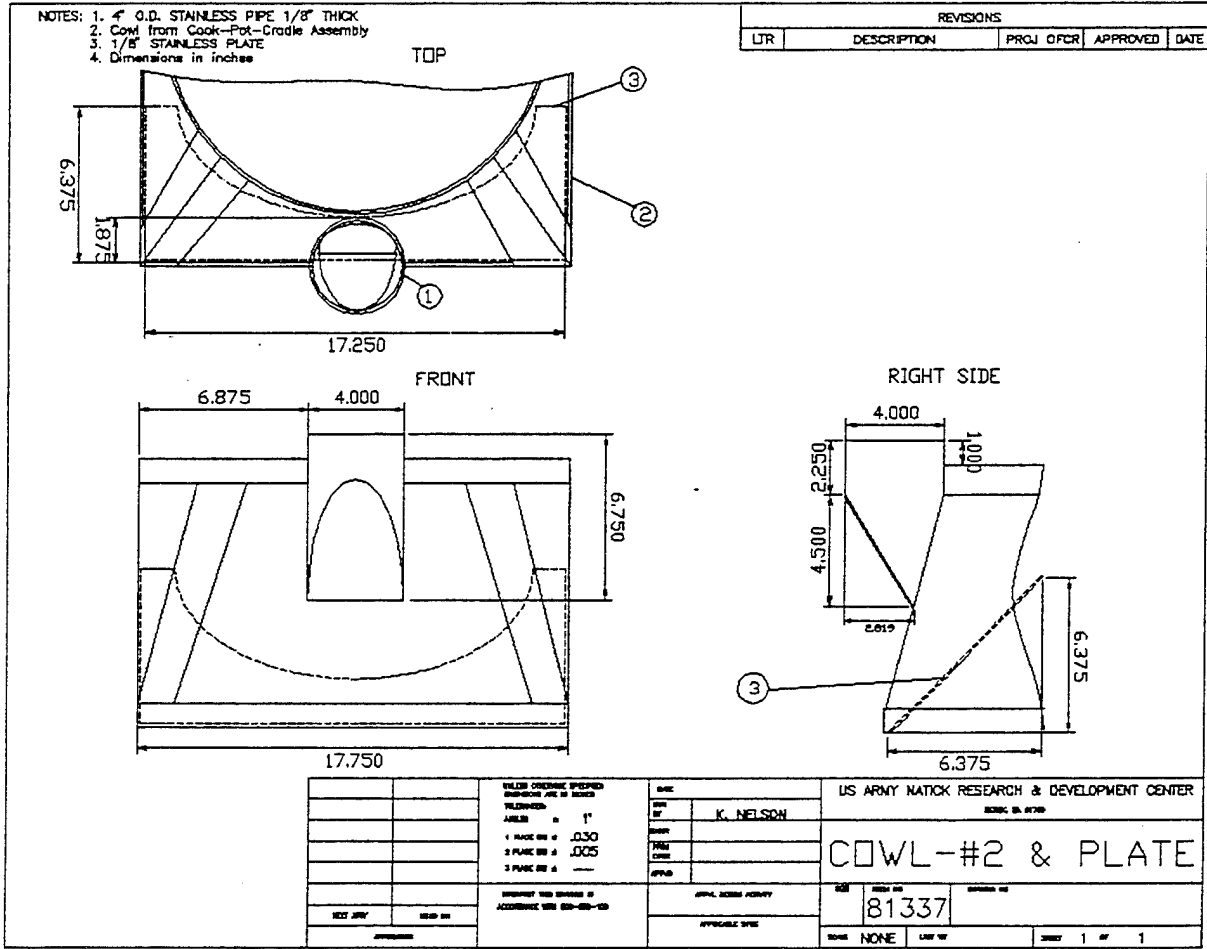

Figure A-11. Drawing plan for Cowl-#2 with half-moon plate added for improved performance of the Grill.

APPENDIX B  
TEST EQUIPMENT & CALIBRATION

## TEST EQUIPMENT

1. Exotox 75 Gas Monitor with System Data Interface to download data to IBM computer. The Exotox 75 gas monitor was used to measure the percent oxygen, the carbon monoxide concentration, percent relative humidity and sulfur dioxide concentration during testing. A picture of the system is shown in Figure B-1.
2. CEA Toxic Gas Monitor (TGM) 555 with a 15 foot sample hose. The TGM 555 monitor was used to measure the formaldehyde concentration during the testing of the equipment vents.
3. OMEGA Temperature recorder. The OMEGA temperature recorder has two thermocouples. The thermocouples were used to measure the ambient temperature and the sampling location temperature (5 ft. from floor at the center of the MKT).
4. LINEAR Chart Recorder. The LINEAR Chart Recorder was used to record the data from the TGM 555 monitor.
5. Miran 103b gas monitor. The Miran 103b gas monitor was used as a substitute monitor for the TGM 555 to measure the formaldehyde concentrations in the MKT during testing in the summer.

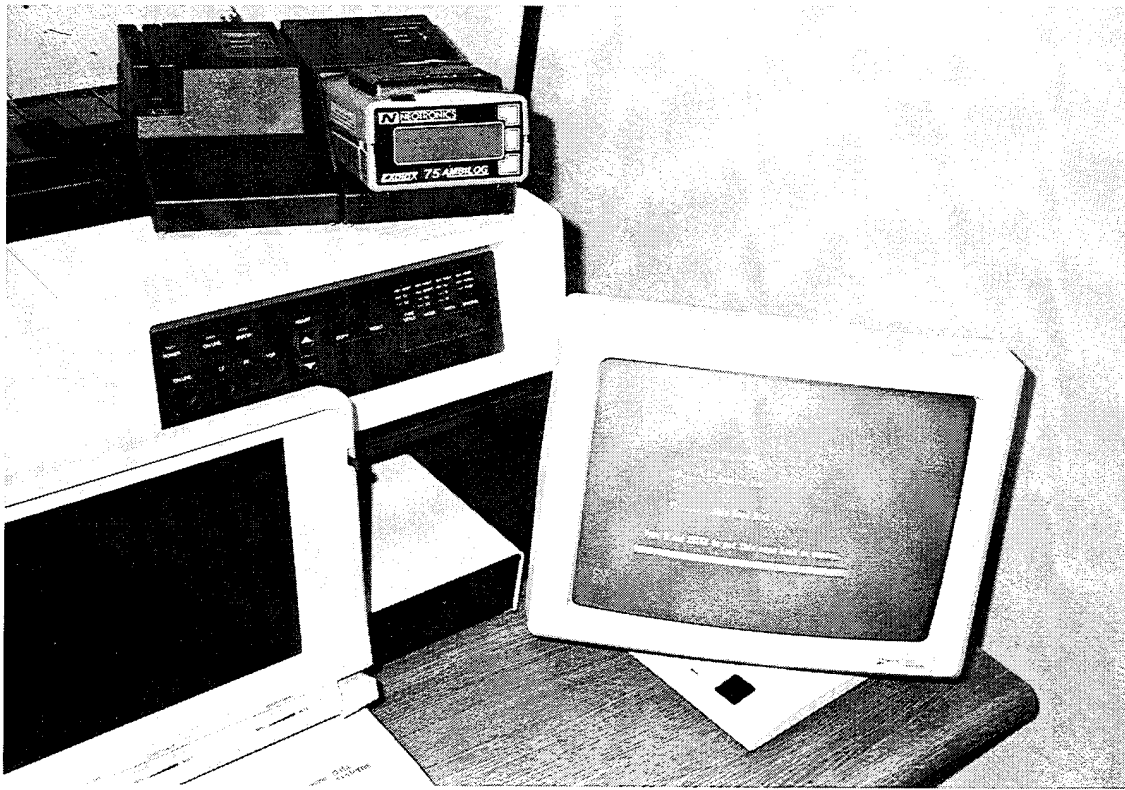

Figure B-1. Exotox 75 Gas Monitor and the System Data Interface for downloading data to the computer.

6. Digistrip III by Kayne Instruments. The Digistrip III was used to monitor the temperatures on the griddle for the performance testing of the griddle.

#### CALIBRATION OF INSTRUMENTS

The calibration of the instruments was completed before testing began, except for those instruments who that were still within their next scheduled calibration date. The TGM 555 monitor was calibrated days before the testing of formaldehyde concentrations within the MKT in the fall. The TGM 555 was initially calibrated in a lab. A day later the calibration of the TGM 555 was checked outside in the test environment, to assure the instrument was working accurately.

BLANK PAGE

APPENDIX C  
M-2 VERSUS M-3 BURNER

## M-2 versus M-3 Burner's Combustion Products

Figure C-1 and C-2 illustrate the difference in the concentration of carbon monoxide when the M-2 and M-3 burners were used within the MKT in the nonvent or baseline configuration. In the figures the average carbon monoxide concentration for the M-2 and M-3 burners are compared at an ambient temperature of 25°F and 35°F (Figures C-1 and C-2 respectively). These figures show the concentration of carbon monoxide within the MKT was similar for both burners. However, it appeared that the M-3 concentration for carbon monoxide was slightly lower than the M-2.

The concentration of oxygen within the MKT when the M-2 and M-3 burners were used in the nonvent or baseline configuration are shown in the lower graphs of Figure C-1 and C-2. The average oxygen concentration in Figures C-1 and C-2 is 19.9% when using the M-3 burners and 18.2% when using the M-2 burners. Just as with the carbon monoxide, the M-3 appeared to provide for slightly better air quality than the M-2.

### CONCLUSION

In the comparison of the M-2 and M-3 burners, the results show a slight advantage of the M-3 burner in the percent oxygen within the MKT. The carbon monoxide concentrations are similar. However, Figures C-1 and C-2 do not provide a thorough analysis for comparing the two burners. Other gases such as formaldehyde, toluene and benzene would need to be tested to draw a final conclusion.

### M-3 VS. M-2 FOR CARBON MONOXIDE - AMBIENT 25 F

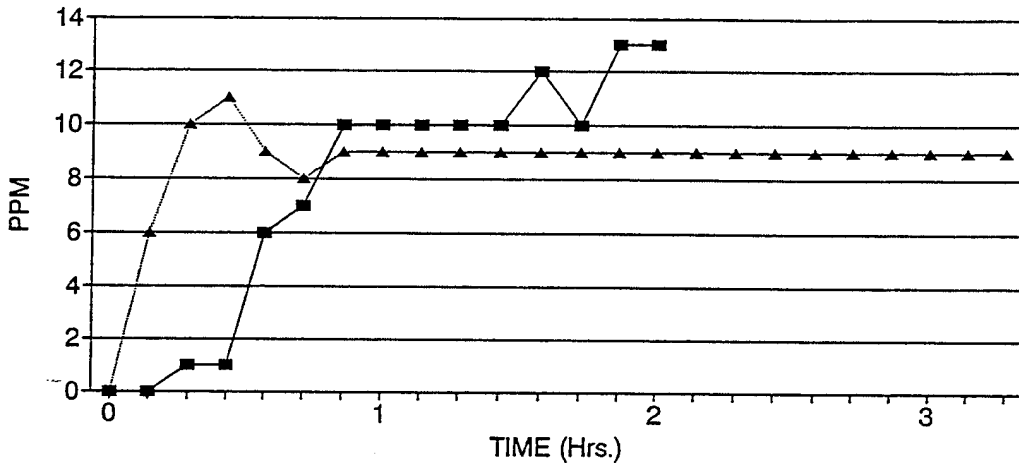

### M-3 VS. M-2 FOR OXYGEN - AMBIENT 25 F

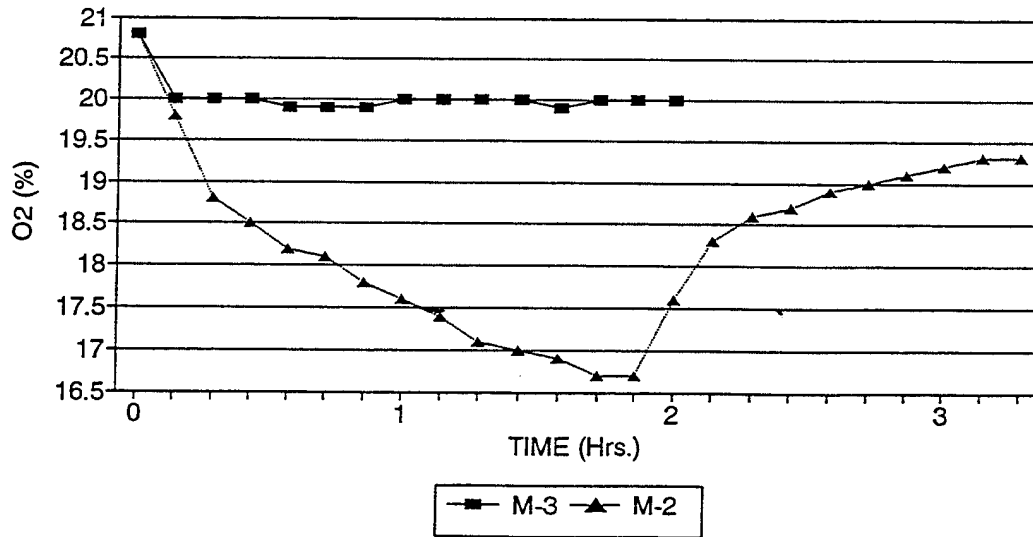
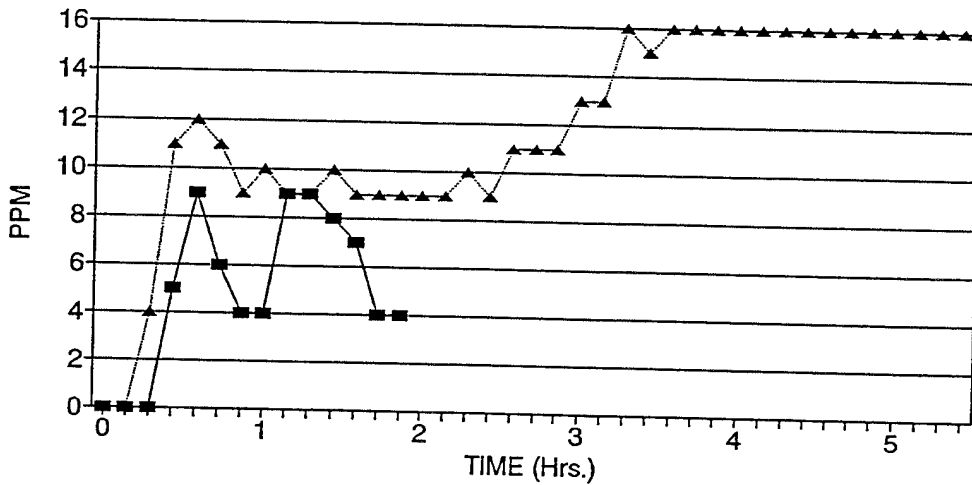

Figure C-1. M-3 versus M-2 burners for carbon monoxide and oxygen concentrations in the Mobile Kitchen Trailer in the nonvent configuration at an ambient temperature of 25°F.

### M-3 VS. M-2 FOR CARBON MONOXIDE - AMBIENT 35 F



### M-3 VS. M-2 FOR OXYGEN - AMBIENT 35 F

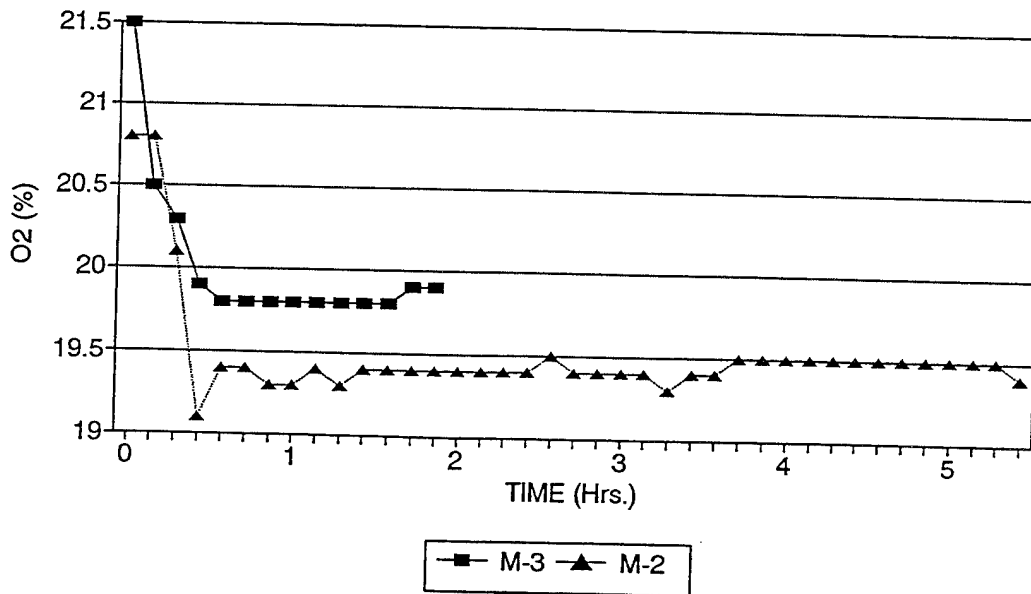

Figure C-2. M-3 versus M-2 burners for carbon monoxide and oxygen concentrations in the Mobile Kitchen Trailer in the nonvent configuration at an ambient temperature of 35°F.