

ESL-TR-89-36

HIGH-TEMPERATURE NO_x CONTROL PROCESS

J.R. KITRELL

KSE, INC.
P.O. BOX 368
AMHERST MA 01004

JANUARY 1995

FINAL REPORT

SEPTEMBER 1988 - MARCH 1989

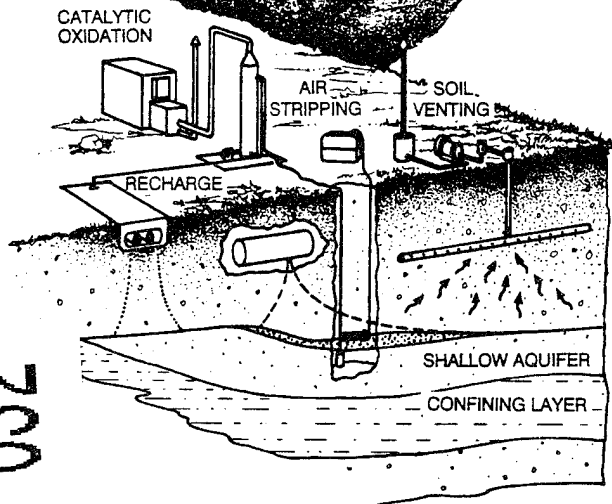
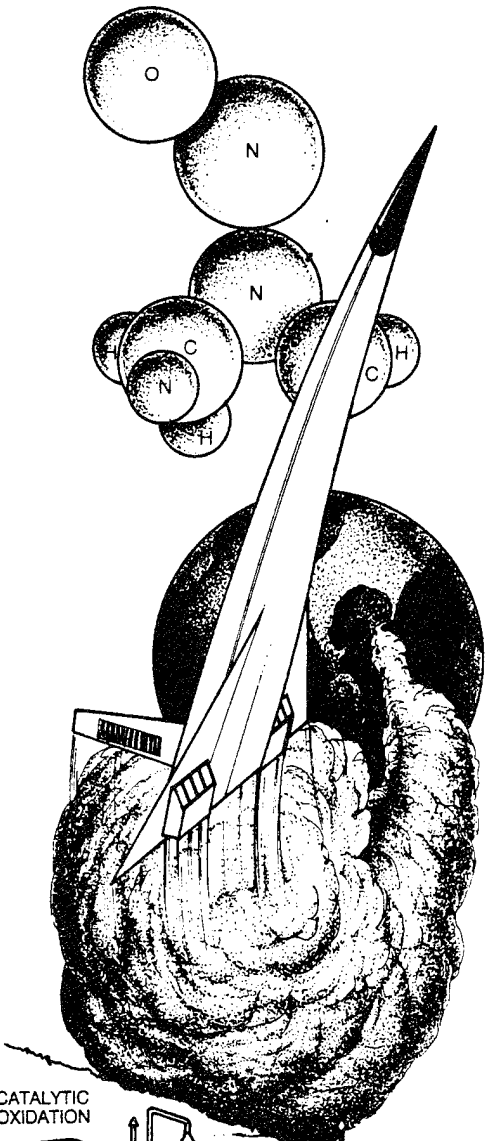

**APPROVED FOR PUBLIC RELEASE:
DISTRIBUTION UNLIMITED**

19950518 032



ENVIRONICS DIVISION
Air Force Civil Engineering Support Agency
Civil Engineering Laboratory
Tyndall Air Force Base, Florida 32403



NOTICES

This report was prepared as an account of work sponsored by an agency of the United States Government. Neither the United States Government nor any agency thereof, nor any employees, nor any of their contractors, subcontractors, or their employees, make any warranty, express or implied, or assume any legal liability or responsibility for the accuracy, completeness, or usefulness of any privately owned rights. Reference herein to any specific commercial product, process, or service by trade name, trademark, manufacturer, or otherwise, does not necessarily constitute or imply its endorsement, recommendation, or favoring by the United States Government or any agency, contractor, or subcontractor thereof. The views and opinions of the authors expressed herein do not necessarily state or reflect those of the United States Government or any agency, contractor, or subcontractor thereof.

When Government drawings, specifications, or other data are used for any purpose other than in connection with a definitely Government-related procurement, the United States Government incurs no responsibility or any obligation whatsoever. The fact that the Government may have formulated or in any way supplied the said drawings, specifications, or other data is not to be regarded by implication, or otherwise in any manner construed, as licensing the holder or any other person or corporation, or as conveying any rights or permission to manufacture, use, or sell any patented invention that may in any way be related thereto.

This technical report has been reviewed by the Public Affairs Office (PA) and is releasable to the National Technical Information Service (NTIS), where it will be available to the general public, including foreign nationals.

This report has been reviewed and is approved for publication.

JOSEPH D. WANDER, PhD

Technical Area Manager, Air Pollution Control Technology

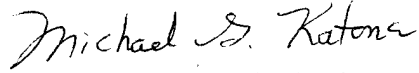
MICHAEL G. KATONA, PhD

EDWARD N. COPPOLA, Maj., USAF
Chief, Environmental Compliance Division

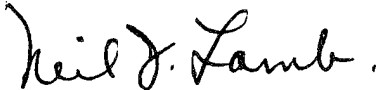
NEIL J. LAMB, Col, USAF, BSC
Director, Environics Directorate

REPORT DOCUMENTATION PAGE

Form Approved
OMB No. 0704-0188

Public reporting burden for this collection of information is estimated to average 1 hour per response, including the time for reviewing instructions, searching existing data sources, gathering and maintaining the data needed, and completing and reviewing the collection of information. Send comments regarding this burden estimate or any other aspect of this collection of information, including suggestions for reducing this burden, to Washington Headquarters Services, Directorate for Information Operations and Reports, 1215 Jefferson Davis Highway, Suite 1204, Arlington, VA 22202-4302, and to the Office of Management and Budget, Paperwork Reduction Project (0704-0188), Washington, DC 20503

| | | | | |
|--|---|--|--|--|
| 1. AGENCY USE ONLY (Leave blank) | | 2. REPORT DATE Jan 95 | 3. REPORT TYPE AND DATES COVERED Final (phase 1) 8809-8903 | |
| 4. TITLE AND SUBTITLE High-Temperature NOx Control Process | | | 5. FUNDING NUMBERS C: F08635-89-C-0065 PE: 65502F Project 3005 WU: 0032 | |
| 6. AUTHOR(S) J.R. Kittrell | | | | |
| 7. PERFORMING ORGANIZATION NAME(S) AND ADDRESS(ES) KSE, Inc. PO Box 363 Amherst MA 01004 | | | 8. PERFORMING ORGANIZATION REPORT NUMBER | |
| 9. SPONSORING / MONITORING AGENCY NAME(S) AND ADDRESS(ES) Armstrong Laboratory, Environics Directorate AL/EQS-OL 139 Barnes Drive, Suite 2 Tyndall AFB FL 32403-5323 | | | 10. SPONSORING / MONITORING AGENCY REPORT NUMBER ESL-TR-89-36 | |
| 11. SUPPLEMENTARY NOTES Project Officers: Maj Wayne P. Chepren, USAF, (HQ AFESC/RDVS) and Dr Joseph D. Wander (AL/EQS); DSN 523-6240/(904) 283-6240 | | | | |
| 12a. DISTRIBUTION AVAILABILITY STATEMENT Unlimited distribution | | | 12b. DISTRIBUTION CODE A | |
| 13. ABSTRACT (Maximum 200 words) KSE has shown that both mordenite and copper mordenite function as effective catalysts for selective catalytic reduction of NOx at medium-to-high temperatures. In this phase 1 SBIR effort, KSE performed calculations and performed limited bench experiments using synthetic exhaust gas to demonstrate that combinations of the two catalysts can be used to provide effective reduction of NOx over a wide range of temperatures in the presence of ammonia. Extensive design calculations were performed based on information from an obsolete jet engine test cell (JETC) and a number of unverified engineering assumptions. Although the interpretation of these computations was considered favorable by the contractor, several features of the proposed design appear to be unfavorable: the back pressure is calculated to be 10 inches wg, which is twice Radian's recommendation to EPA, and 10 times the Air Force's target value; | | | | |
| 14. SUBJECT TERMS Air pollution control; nitrogen oxides; combustion; gas turbine engines, test cells; stationary source | | | 15. NUMBER OF PAGES | |
| | | | 16. PRICE CODE | |
| 17. SECURITY CLASSIFICATION OF REPORT UNCLASSIFIED | 18. SECURITY CLASSIFICATION OF THIS PAGE UNCLASSIFIED | 19. SECURITY CLASSIFICATION OF ABSTRACT UNCLASSIFIED | 20. LIMITATION OF ABSTRACT UNLIMITED | |

13. Abstract (Continued)

the reagent is ammonia, which is a regulated emission and also flammable and toxic to biological systems; wind stress in a test cell places a tremendous requirement for structural strength of anything to be installed in the airflow's path.

Whereas this concept will not be pursued for JETCs, the wide range of applicable temperatures and claimed short contact time for reaction suggest that combinations of these catalysts may be practical for less-exotic applications.

| | |
|---------------------|-------------------------------------|
| Accession For | |
| NTIS CRA&I | <input checked="" type="checkbox"/> |
| DTIC TAB | <input type="checkbox"/> |
| Unannounced | <input type="checkbox"/> |
| Justification | |
| By | |
| Distribution / | |
| Availability Codes | |
| Dist | Avail and/or Special |
| A-1 | |

EXECUTIVE SUMMARY

A. OBJECTIVE

The overall goal of the Phase I research program was to examine the applicability of a recently developed catalyst formulation to the selective catalytic reduction (SCR) of oxides of nitrogen (NO_x) under the high-temperature conditions presumed to exist in jet engine test cells (JETCs) or incinerators. The catalyst system is unique in that (a) it exhibits very high activity, (b) it maintains this activity at temperatures of at least 600°C without promoting undesirable side reactions leading to reduced NO_x conversions, (c) it can be configured to provide high activity over a wide range of temperatures, and (d) it utilizes ammonia very efficiently, due to the absence of side reactions. The principal emphasis of the study was on the JETC.

B. BACKGROUND

The Air Force anticipates need for control of NO_x emissions from two major source categories involving exhaust temperatures far above those typical of utility boilers. Incineration of refractory organic materials, such as energetic materials, chemical agents, and medical wastes, uses temperatures as high as 760°C for extended periods of time, which promotes formation of high levels of NO_x . Stationary JETCs also emit large quantities of NO_x . As with peaking turbines in the utility industry, the concentrations of NO_x are relatively lower (100 - 200 ppm), but the quantities emitted are sufficient to cause brownish plumes. Exhaust temperatures at or above 480°C are not uncommon in jet engines. Any modification to the jet engine operating system must be so limited as to cause no change in the performance optimization of the system.

C. SCOPE

This report is the product of a Phase I Small Business Innovation Research project. It details a token laboratory evaluation of combinations of two published catalysts to conditions presumed to exist in JETCs. The main body of the report is development, from the same presumptions and a few unverified assumptions about JETC operating characteristics, of a detailed design for application of the two-catalyst technology to an obsolete JETC at Tinker AFB OK.

D. METHODOLOGY

Conventional technology was used to measure NO_x removal from a synthesized exhaust stream using combinations of two catalysts at several temperatures. Engineering models and arbitrary assumptions were used to translate information about a JETC at Tinker AFB OK into a proposed design for a control system.

E. TEST DESCRIPTION

A bench-scale setup was fitted with a catalyst bed (the composition being varying mixtures of two mordenite preparations) and maintained at one of several arbitrarily selected temperatures. A synthetic combustion exhaust stream was passed through the catalyst for treatment, and the concentrations of the nitrogenous oxides was determined before and after treatment.

F. RESULTS

Satisfactory results were observed, reductions by copper mordenite being very efficient from about 250 to 400°C, and reductions by hydrogen mordenite being effective at higher temperatures to more than 600°C. Results reported earlier also indicate efficient conversions at fairly short contact times, suggesting potential utility for these catalysts in SCR applications. Reactor designs are presented, projecting 80- to 90-percent conversion over the entire test cycle for both the J79-17G engine and the TF33-P3 engine (assuming laminar flow in the augments tube, that the exhaust is unaffected by passage through the JETC to the point of treatment, and that the engine can tolerate 10 inches wg of back pressure). The designs appear to be specific to the single JETC at Tinker AFB for which information was collected. Alternative designs were also presented for a catalyst block between the augments tube and the muffler, and designs are presented for an incinerator application.

G. CONCLUSIONS

As the design exceeds by 100 percent the pressure drop proposed by Radian in 1986, and the JETC to which it is scaled is obsolete and not widely distributed among Air Force installations, it will not be pursued. Additional considerations supporting the decision not to pursue development included that storage and use of a flammable, toxic liquid adjacent to and in a combustion facility also enhances both regulated emissions and health and safety hazards, and that several of the engineering assumptions employed are counterintuitive.

H. RECOMMENDATIONS

The mordenites may prove to be satisfactory for steady-state and near-steady-state SCR applications to sources that are insensitive to back pressure in contexts in which ammonia is an acceptable hazard to manage; however, for Air Force JETCs the concept of SCR appears to be incompatible with both pressure drop and structural integrity requirements.

TABLE OF CONTENTS

| Section | Title | Page |
|---------|---|------|
| I | INTRODUCTION | 1 |
| | A. OBJECTIVE | 1 |
| | B. BACKGROUND | 1 |
| | C. SCOPE | 3 |
| II | CATALYST SELECTION | 4 |
| | A. COPPER MORDENITE DATA | 6 |
| | B. HYDROGEN MORDENITE DATA | 7 |
| | C. CATALYST SELECTION | 10 |
| III | REACTOR SECTION DESIGN | 13 |
| | A. REACTOR DESIGN MODEL | 13 |
| | B. MODEL VALIDATION | 15 |
| | C. REACTOR DESIGN BASIS | 16 |
| | D. BASE CASE DESIGN: ENGINE TEST CELL | 19 |
| | E. BASE CASE DESIGN: INCINERATOR | 24 |
| | F. ALTERNATIVE DESIGNS | 27 |
| IV | OVERALL PROCESS DESIGN | 38 |
| | A. DESIGN BASIS | 41 |
| | B. OVERALL PROCESS DESCRIPTION | 42 |
| | 1. SCR Reactor Section | 47 |
| | 2. Process Piping | 47 |
| | 3. Emission Mounting Unit | 47 |
| | 4. Process Controller Unit | 48 |
| | 5. Ammonia Management System | 48 |
| | 6. Sampling and Monitoring System | 49 |
| | 7. Process Control | 50 |
| | 8. Cost Estimates | 71 |

TABLE OF CONTENTS (CONCLUDED)

| Section | Title | Page |
|---------|---|------|
| C. | MECHANICAL DESCRIPTION | 61 |
| 1. | Turbine Test Cell | 61 |
| 2. | Catalyst Block Design | 61 |
| 3. | Reactor Module | 61 |
| 4. | Loading an Unloading Mechanism | 61 |
| 5. | Ammonia Injection Grid | 62 |
| D. | INCINERATOR MECHANICAL SYSTEM DESCRIPTION | 62 |
| 1. | Catalyst Block Design | 65 |
| 2. | Catalyst Panel Design | 65 |
| 3. | Catalyst Housing | 65 |
| 4. | Loading and Unloading | 65 |
| 5. | Ammonia Injection Grid | 65 |
| E. | CATALYST FABRICATION AND COST | 66 |
| V | CONCLUSIONS AND RECOMMENDATIONS | 67 |
| A. | CONCLUSIONS | 67 |
| B. | RECOMMENDATIONS | 68 |
| | REFERENCES | 69 |

LIST OF FIGURES

| Figure | Title | Page |
|--------|--|------|
| 1 | Activity Maxima of Some NO _x Reduction Catalysts | 2 |
| 2 | High-Temperature Performance of Copper Mordenite Catalyst | 4 |
| 3 | Excellent Selectivity of Copper Mordenite Catalyst | 5 |
| 4 | First-Order Behavior for Copper Catalyst | 7 |
| 5 | Decrease in NO _x Conversion at Very High Temperature for Copper Catalyst | 8 |
| 6 | Arrhenius Behavior of First-Order NO _x Rate Constant for Copper Catalyst .. | 9 |
| 7 | First-Order Behavior for Mordenite Catalyst at High Temperatures | 10 |
| 8 | Arrhenius Behavior of First-Order NO _x Rate Constant at High Temperatures for Mordenite Catalyst | 11 |
| 9 | PPR Model Validation for Mordenite Catalyst: Low Temperature | 16 |
| 10 | PPR Model Validation for Mordenite Catalyst: Intermediate Temperature .. | 17 |
| 11 | PPR Model Validation for Mordenite Catalyst: High Temperature | 18 |
| 12 | PPR Model Validation for Dual-Bed Catalyst: Low Temperature | 19 |
| 13 | PPR Model Validation for Dual-Bed Catalyst: Intermediate Temperature ... | 20 |
| 14 | PPR Model Validation for Dual-Bed Catalyst: High Temperature | 21 |
| 15 | Illustrative Design Calculations for SCR Reactor | 22 |
| 16 | Base Case Reactor Design for J79-17G Engine Test Cell | 23 |
| 17 | Base Case Reactor Pressure Drop for J79-17G Engine Test Cell | 24 |
| 18 | Base Case Incinerator Reactor Design | 25 |
| 19 | Expanded Gap Spacing Incinerator Reactor Design | 26 |
| 20 | Alternate Reactor Design for TF33-P3 Engine Test Cell: 260°C | 28 |
| 21 | Alternate Reactor Design for TF33-P3 Engine Test Cell: 315°C | 29 |
| 22 | Alternate Reactor Design for TF33-P3 Engine Test Cell: 373°C | 30 |
| 23 | Alternate Reactor Design for TF33-P3 Engine Test Cell: 434°C | 31 |
| 24 | Reactor Design with Catalyst in Flat Bed: 371°C | 33 |
| 25 | Reactor Design with Catalyst in Flat Bed: 427°C | 34 |
| 26 | Reactor Design with Catalyst in Flat Bed: 482°C | 35 |
| 27 | Reactor Design with Catalyst in Flat Bed: 538°C | 36 |
| 28 | Reactor Design with Catalyst in Flat Bed: 593°C | 37 |
| 29 | Overall Process Schematic Design | 39 |
| 30 | Overall General Arrangement Diagram | 43 |
| 31 | Process and Instrumentation Diagram | 45 |
| 32 | Emission Monitoring Unit Process and Instrumentation Diagram | 51 |
| 33 | Process Control Unit | 53 |
| 34 | Test Cell | 59 |
| 35 | Incinerator | 63 |

LIST OF TABLES

| Table | Title | Page |
|-------|---|-------|
| 1 | ENGINE OPERATING CONDITIONS: J79-17G | 11 |
| 2 | TABULATION OF PPR DESIGN EQUATIONS | 14 |
| 3 | DESIGN BASIS FOR ENGINE TEST CELL | 18 |
| 4 | EXHAUST CONDITIONS FOR TF33-P3 ENGINE | 27 |
| 5 | EQUIPMENT COST ESTIMATE | 56-58 |

NOMENCLATURE

| | | |
|------------|---|--|
| D_{NO} | = | diffusivity of nitric oxide |
| e | = | surface roughness factor |
| f | = | friction factor |
| f_r | = | friction factor for rough surfaces, Equation (11) |
| f_s | = | friction factor for smooth surfaces, Equation (10) |
| g_c | = | gravitational conversion factor |
| k_s | = | intrinsic surface rate constant |
| K_e | = | effective rate constant of Equation (5) |
| K_w | = | dimensionless wall rate constant of Equation (8) |
| L | = | reactor length |
| Nu | = | Nusselt number |
| Nu_r | = | Nusselt number for rough surfaces |
| Nu_s | = | Nusselt number for smooth surfaces |
| R | = | one-half of gap width of parallel screens in reactor |
| Re | = | Reynolds number |
| Sc | = | Schmidt number |
| U | = | linear gas velocity |
| X | = | dimensionless reactor length of Equation (6) |
| x_{NO} | = | fractional conversion of NO |
| ρ | = | gas density |
| ΔP | = | reactor pressure drop |

SECTION I

INTRODUCTION

A. OBJECTIVE

The overall goal of the research program is the adaptation of an existing catalytic device to the selective catalytic reduction of NO_x exhausted by jet engine test cells or incinerators. In Phase I, basic data were collected to permit a complete design of the system. The specific objectives of the work program were as follows:

- 1) Selection of the optimal catalyst composition for operation at (a) 510°C and (b) 760°C , through laboratory data.
- 2) Design of the reactor section of the process.
- 3) Design of the overall process and process control system.

B. BACKGROUND

The Air Force has two major areas of need for control of oxides of nitrogen (NO_x), which involve exhaust temperatures substantially above typical utility boiler applications. Incineration of refractory organic materials, such as explosives, chemical agents, and medical wastes, requires high temperatures for extended periods of time. These conditions, which employ temperatures as high as 760°C , lead to formation of particularly high levels of NO_x . Stationary jet engine test cells also emit substantial quantities of NO_x . As with peaking turbines in the utility industry, the concentrations of NO_x are relatively lower (100 - 200 ppm) but the quantities emitted are sufficient to cause brownish plumes. Exhaust temperatures at or above 480°C are not uncommon in jet engines. Any modification to the jet engine operating system must be so limited as to cause no change in the performance optimization of the system.

Processes using ammonia for the selective catalytic reduction (SCR) of NO_x have been extensively developed over the past two decades. However, these SCR processes have been developed primarily for utility boilers, and are generally limited to constant operating temperatures near 400°C . These utility SCR systems may be ineffective for time-dependent or high-temperature emission sources. Heat-transfer devices may be used to cool the hot gas to about 400°C , but such SCR devices are expensive, large, difficult to control and maintain, and negatively influence engine performance (through their pressure drop). Furthermore, the catalysts developed for coal or oil

service are of relatively low activity, requiring large catalyst volumes. Finally, the chemical composition of these catalysts requires a relatively high ammonia consumption, adding to their operating costs.

The selective catalytic reduction (SCR) of nitrogen oxides uses ammonia (NH₃) in gaseous form, which is diluted in air to about 5 percent by volume and injected into the exhaust flue gas from an incinerator or from a jet engine. Conventional systems used to accomplish this employ metallic-oxide catalysts. For the reaction, covalently bound oxygen is drawn from the metallic oxide and then replaced by adsorption of oxygen from the air in the exhaust gas (Reference 1). These metallic-oxide catalysts require a reaction stoichiometry of at least one unit of NH₃ per unit of NO_x:

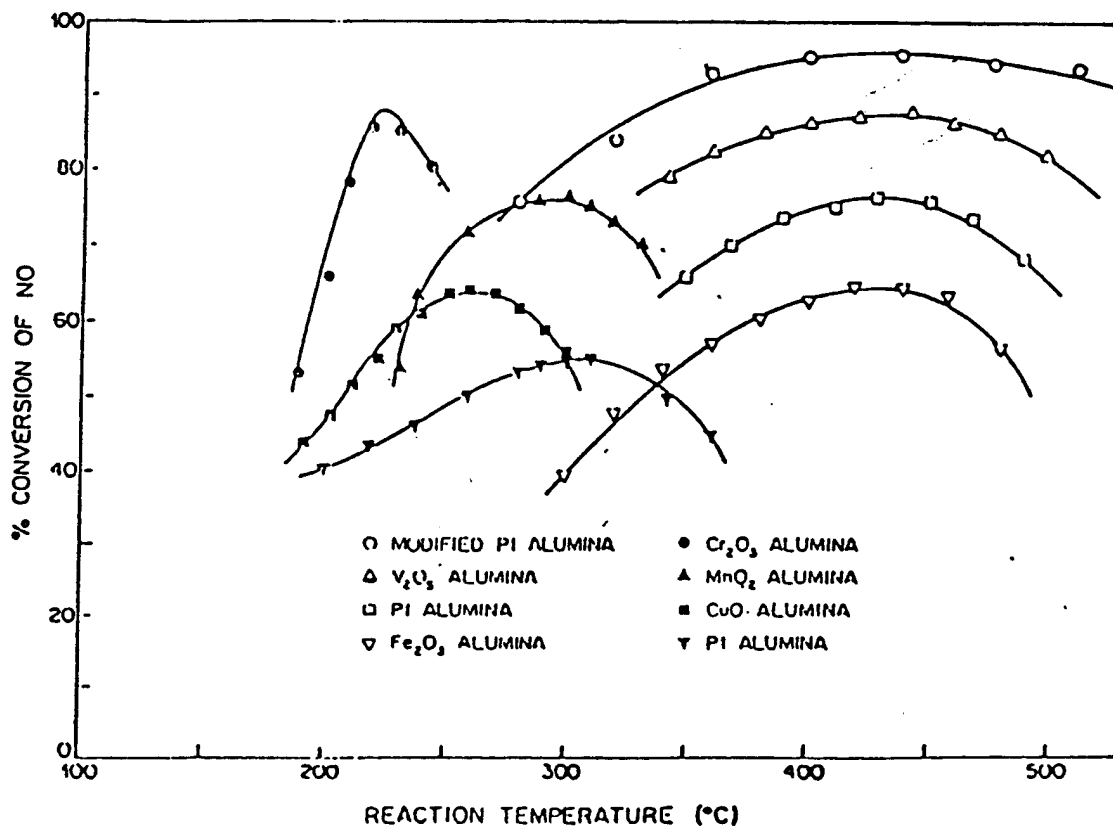
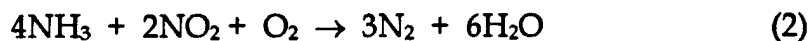
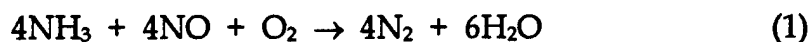

Figure 1. Activity Maxima of Some NO_x-Reduction Catalysts. (Space Velocity 20k hr⁻¹ [STP]) [From Yamaguchi (1976), Reference 3.]

Furthermore, with such conventional catalysts, the reaction temperature range is generally restricted to about 400°C (Reference 2). In addition, because the catalyst activity is relatively low, the amount of catalyst required is relatively large. This results in low space velocities (ratio of gas flow rate to catalyst volume). Figure 1 reports the results of various catalyst studies by Japanese researchers (Reference 3). Note that the catalytic conversion of the common vanadium catalyst peaks at 400°C. At higher temperatures, the oxygen in the metallic oxide catalysts converts substantial levels of NH₃ into NO_x, decreasing the observed conversion level, as typified by



This is undesirable for several reasons. Clearly, the reaction unnecessarily consumes ammonia, thus increasing operating costs. Second, to avoid the decline in performance above 400°C, the operating range of the catalyst must be restricted to about 400°C (Reference 2). This is particularly undesirable for stationary jet engine and incinerator applications, since heat transfer devices must be used to cool the gas to about 400°C. These devices are expensive, add pressure drop, and are difficult to control and maintain.

C. SCOPE

In the present program, a high-temperature SCR catalyst previously developed (References 4 and 5) by Dr. J.R. Kittrell, the principal investigator, was evaluated to ascertain its suitability for the military applications discussed above. Since the catalyst bed involves a mixture of two different catalysts, kinetic data had to be evaluated to ascertain the optimal mixture of catalysts. Then, the reactor design for the preferred catalyst had to be completed, balancing catalyst gap spacing, reactor length, NO_x conversion and pressure drop. Finally, the overall process design was to be completed, permitting an assessment of military application of the SCR system.

Because of the high activity of the catalyst, the design was specifically examined to determine if the catalyst could be incorporated into the existing engine test cell without incorporation of additional reactors. Indeed, this appears to be possible, using the muffler tubes as the reactor to hold the catalyst. Although cost evaluations were outside the scope of the study, some investment data were identified for future program guidance.

SECTION II

CATALYST SELECTION

The catalyst system employed for the KSE process is a mordenite plus copper mordenite dual-bed system. A zone of mordenite catalyst is upstream of a zone of copper mordenite catalyst. The amount of catalyst to be used in each zone depends primarily upon reactor temperature, and, to a lesser degree, on entering NO_x concentration. In the present task, reaction data are summarized to permit reactor design in Section III. Although the reactor configuration to be used in the reactor is to be of a low-pressure-drop design, KSE can confidently predict these design parameters from data collected in packed-bed reactors. Hence, packed-bed reactors, which are simpler to construct and operate, were used for the data collection.

The mechanistic behavior of the mordenite and the copper mordenite catalysts have been studied in a Ph.D. thesis (Reference 6) and their high-temperature dual-bed operation has been confirmed in an M.S. thesis (Reference 7), both supervised by the principal investigator, Dr. J.R. Kittrell. Briefly, the mordenite is a small-pore zeolite that is extremely stable at temperatures up to 800°C . The copper mordenite uses copper which is ion-exchanged into the mordenite on a molecular scale, to produce an extremely active SCR catalyst.

Considering first the copper mordenite catalyst, Figure 2 displays the continuing increase in conversion of nitric oxide as its temperature is increased, in contrast to deteriorating performance of a conventional vanadium catalyst. This is because the copper mordenite catalyst does not utilize lattice oxygen (Reference 6), as do the vanadium oxide or iron oxide catalysts (Reference 1). As a result, in contrast to the

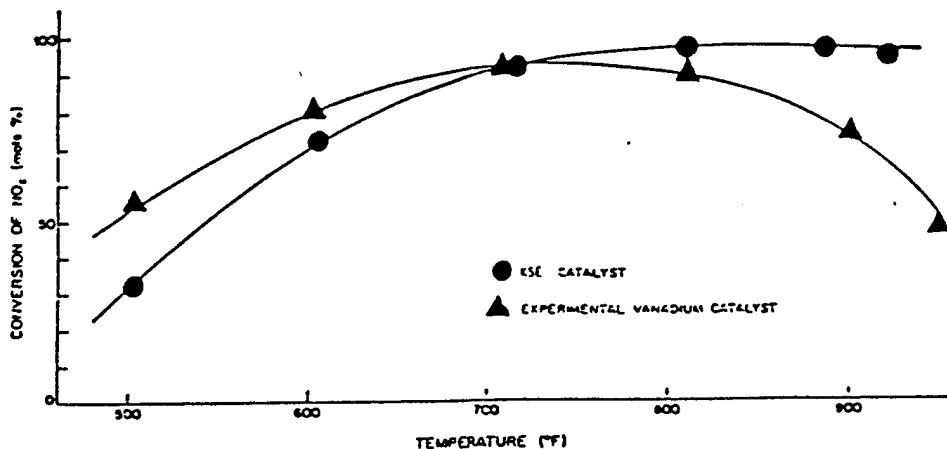
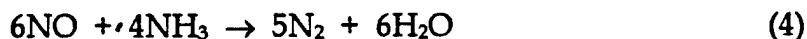

Figure 2. High-Temperature Performance of Copper Mordenite Catalyst.

reactions of Equations (1) and (2), the copper mordenite converts nitric oxide by the process



Because oxygen does not participate in Equation (4), the copper mordenite catalyst consumes less NH_3 . This has been confirmed experimentally (Reference 6), where the data of Figure 3 reflect the two-thirds ratio required by Equation (4). Because of this excellent selectivity, the catalyst can be operated at high temperatures and thus at high space velocity.

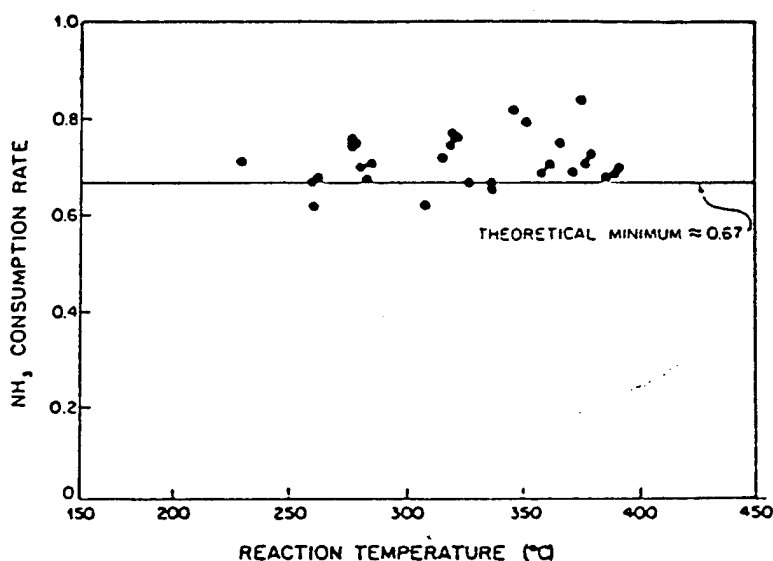

Figure 3. Excellent Selectivity of Copper Mordenite Catalyst.

Depending on space velocity, even the copper mordenite catalyst develops a nonselective oxidation of ammonia through Equation (3) at sufficiently high temperatures (over 500°C). At such high temperatures, the mordenite catalyst (without copper) develops appreciable activity, even though it is relatively less active at low temperatures of about 400°C. At these high temperatures, it is effective to use a prebed of mordenite to selectively remove most of the NH_3 by Equation (4), without any participation of Equation (3) (because no copper is present). Then, the high-activity copper mordenite is used to complete the reaction, after most of the NH_3 has been reacted with NO_x in the prebed.

For the data reported below, a laboratory flue gas was generated by a 100,000-Btu/hr Utica model 8GB04 home heating furnace that burned propane gas at a rate of 42 standard cubic feet per hour. Usually the flue gas contained 45 ppm of NO (as

measured by chemiluminescent analyzer). The concentrations of other flue gas components were 5.8 percent CO₂, 8.6 percent H₂O, 12.1 percent O₂, and 73.5 percent N₂, as determined by gas chromatography (for CO₂, O₂, and N₂) and hygrometer (for H₂O). A slip stream of flue gas was drawn from the furnace stack using a Gast Model 1550-P sliding vane pump. The gas flowed through a 3.81-cm diameter by 15.24-cm filter.

Since the cold-burning propane furnace does not produce enough NO, additional NO had to be added to the system to increase the concentration into the range of 200 to 1500 ppm. Ammonia was also added to approximately equal concentrations with the nitric oxide.

A packed-bed, continuous-flow, integral reactor was used to obtain the experimental data. The reactor was a vertical 3-foot x 3/8-inch O.D. Type 6061 aluminum tube with a piece of 40-mesh stainless steel screen inserted horizontally midway into the tube. The screen supported the 0.5-gram catalyst bed resting on a 3-inch gas preheating bed of 5-mm glass beads resting on top of the catalyst bed. The reactor was placed in a Lindberg HeviDuty Type 4357A three-zone furnace equipped with three 200°C to 1200°C controllers. The furnace had a large central automatic control zone, and two smaller preheat and afterheat zones.

Nitric oxide concentrations were measured with a Thermo Electron Chemiluminescent NO-NO_x Gas Analyzer, Model 10AR. Ammonia measurements were performed with Kitagawa indicator tubes.

The mordenite catalyst was purchased from the Norton Company of Akron, Ohio, as Zeolon 900H. The copper mordenite was produced by ion exchange of Zeolon 900H.

A. COPPER MORDENITE DATA

Data on reduction of NO_x by NH₃ have been investigated in many MS and Ph.D. programs directed by the principal investigator since 1970. It has been found that copper mordenite provides pseudo-first-order kinetics at temperatures below about 400°C, but that the kinetics become complicated by the parallel ammonia oxidation reaction at higher temperatures.

The data of Figures 4 and 5 confirm this expectation. The first-order behavior at temperatures of 266°C, 315°C, and 399°C is quite evident from Figure 4. In Figure 5, further increases in temperature to 597°C result in a declining conversion, obviously not first-order. This declining conversion is due to the onset of the reaction of Equation (3). The apparent activation energy of the Arrhenius plot of Figure 6 is 9 kcal/g-mole.

Note, from Figure 5, the extremely high space velocities with this catalyst, compared to those reported in Figure 1 for competitive catalysts.

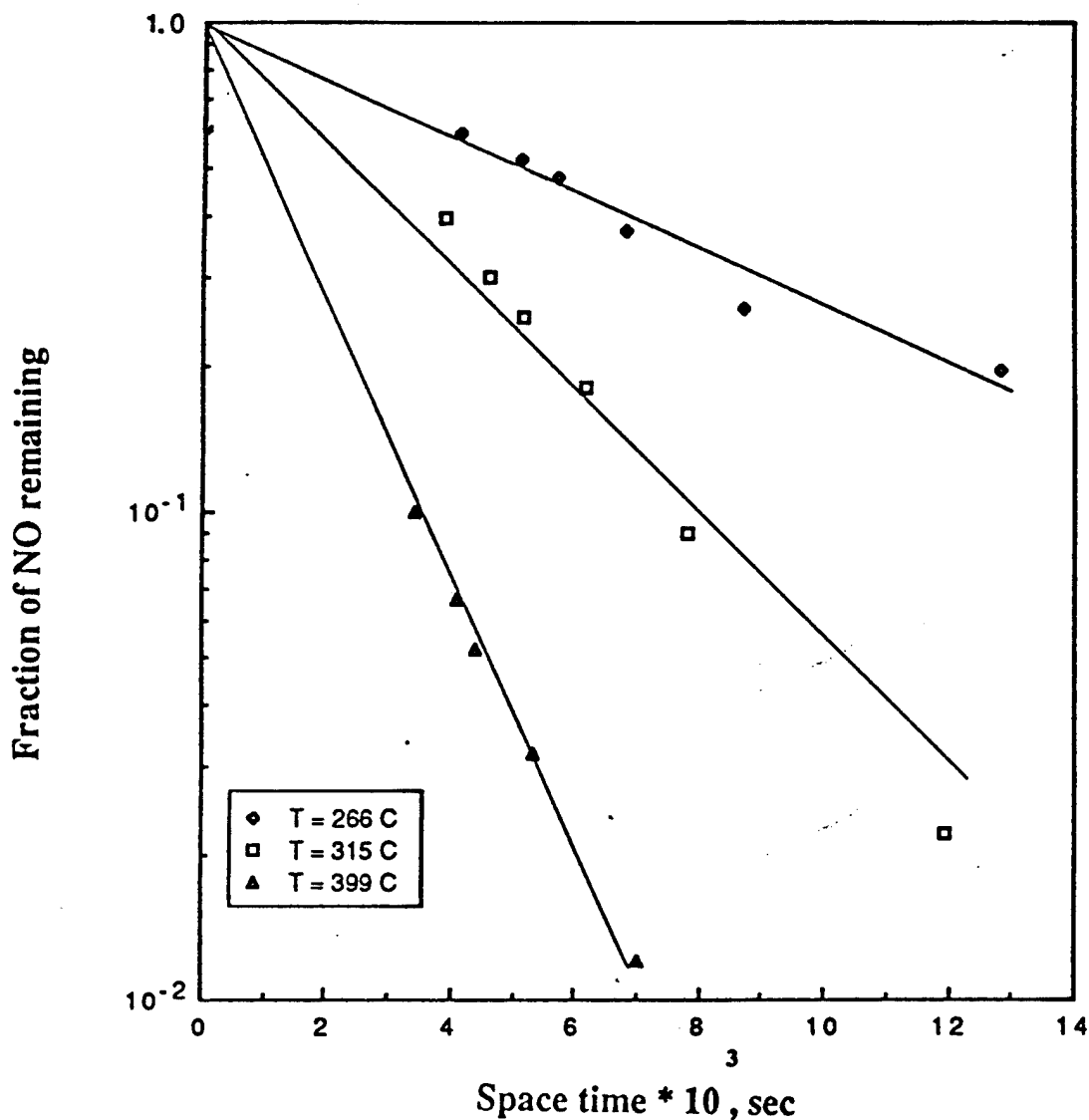

Figure 4. First-Order Behavior for Copper Catalyst; $\text{NH}_3/\text{NO} = 1.0$.

B. HYDROGEN MORDENITE DATA

When hydrogen mordenite is used as a catalyst for the selective conversion of nitrogen oxides by ammonia, it is unique compared to other catalytic systems in that it contains no catalytic metal, such as copper, vanadium, or platinum. These metals are normally considered to be adsorption sites for nitric oxide. The support, such as the zeolite, alumina, or titania, is effective for adsorption of ammonia, the other reactant. Unlike other supports, the small-pore mordenite appears able to adsorb some significant levels of nitric oxide, perhaps because of its small pore size distribution

(Reference 6); however, the nitric oxide adsorption on the mordenite is less than on the copper mordenite.

As a result, the mordenite catalyzed reaction rate is less at low temperatures than that catalyzed by copper mordenite. The rate data for mordenite are reported in Figure 7. Note, at 4×10^{-3} seconds space time, for example, that the mordenite catalyzed conversion at 414°C is less than that produced by the copper mordenite catalyst of Figure 4 at 399°C .

However, in the absence of the catalytic metal, the undesirable ammonia oxidation side reaction of Equation (3) does not occur at high temperatures. The mordenite catalyst does not promote oxidation reactions, whereas the metallic catalysts become highly active for this undesirable side reaction. As a result, the metallic catalysts shows a maximum in a conversion versus temperature plot, due to the formation of nitric oxide by Equation (3). This is evident for the copper mordenite in Figure 5 and for a variety of other common selective catalytic reduction (SCR) catalysts in Figure 1.

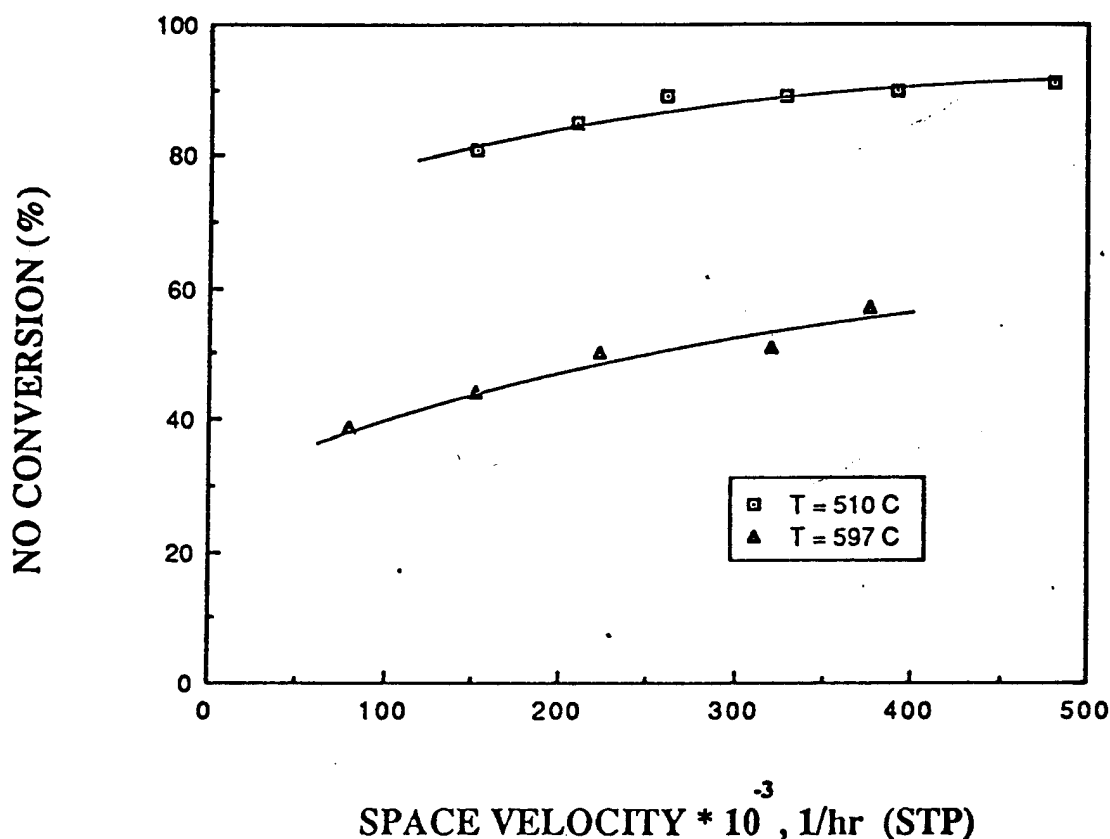

Figure 5. Decrease in NO_x Conversion at Very High Temperatures for Copper Catalyst; NH₃/NO_x = 1.0.

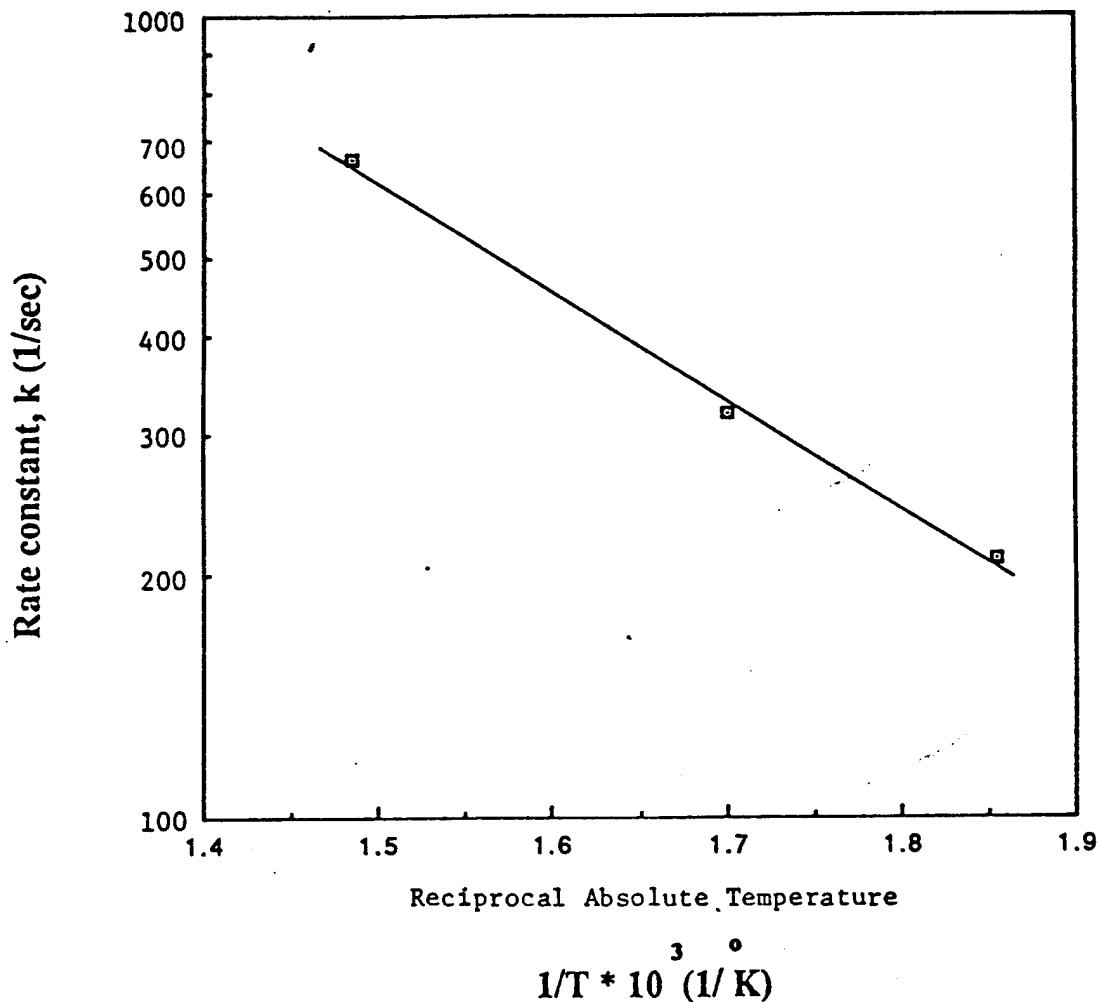

Figure 6. Arrhenius Behavior of First-Order NO_x Rate Constant for Copper Catalyst.

As a result, the hydrogen mordenite catalyst shows continuously increasing conversion with increasing temperature, as shown in Figure 7. By 554°C, the hydrogen mordenite is more active than the copper mordenite at any temperature between 266°C and 597°C, as evident by a comparison of Figure 7 to Figures 4 and 5. Note that the mordenite catalyst thus allows operation at extremely high space velocities.

As shown in Figure 7, the reaction is pseudo-first-order. The activating energy, from the Arrhenius plot of Figure 8, is 14,000 cal/g-mole.

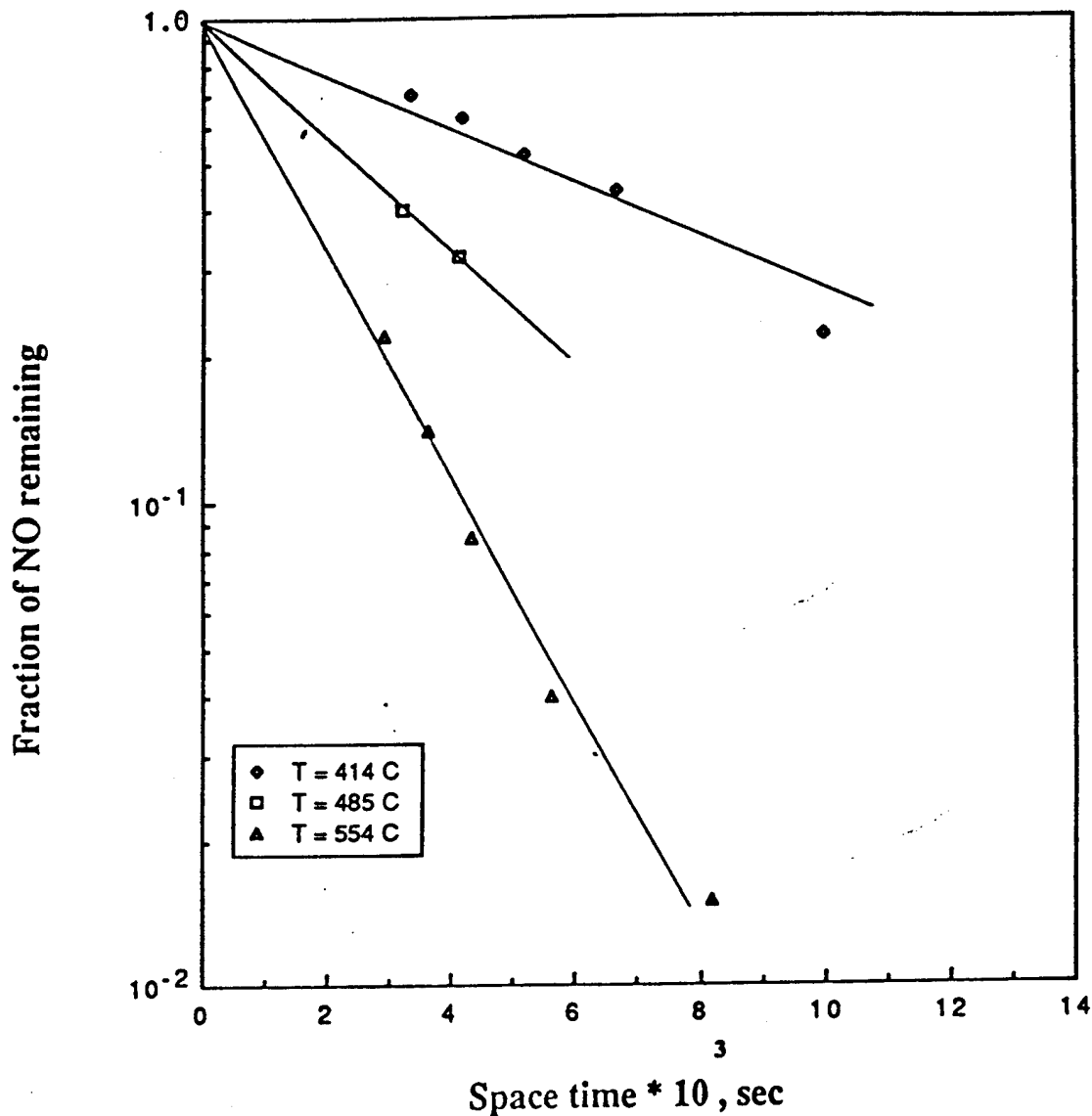

Figure 7. First-Order Behavior for Mordenite Catalyst at High Temperatures.

C. CATALYST SELECTION

The dual-bed catalyst concept entails placing a layer of mordenite upstream of a layer of copper mordenite. At low temperatures, the mordenite layer converts relatively little NO_x but the copper mordenite is highly active without significant contribution to the undesirable side reaction of Equation (3). At high temperatures, the mordenite catalyst converts all of the NH_3 and NO_x . Since no ammonia remains when the gas reaches the copper mordenite catalyst, the undesirable side reaction of Equation (3) does not occur, even at high temperatures. The amount of catalyst in each zone depends upon the specific temperatures and flow rates to be employed.

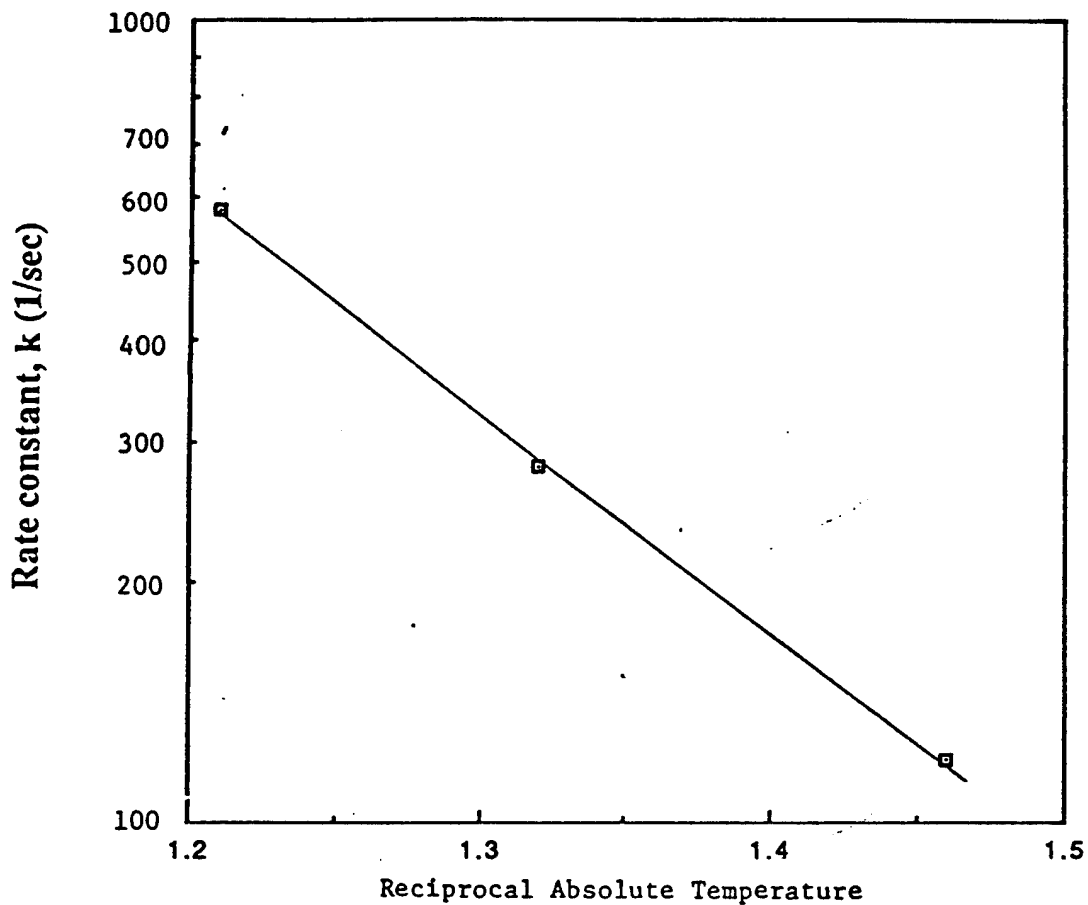

Figure 8. Arrhenius Behavior of First-Order Rate Constant for Reduction of NO_x at High Temperatures over Mordenite Catalyst.

For the J79-17G engine, typical exhaust conditions are as follows:

TABLE 1. ENGINE OPERATING CONDITIONS: J79-17G¹

| <u>Power Setting</u> | <u>Idle</u> | <u>30%</u> | <u>75%</u> | <u>100%</u> |
|------------------------------|-------------|------------|------------|-------------|
| Air Flow (lb/sec) | 45.2 | 97.7 | 143.6 | 164.8 |
| Outlet Temp (°C) | 315 | 314 | 507 | 609 |
| NO _x (ppm) | 9.5 | 18.0 | 52.5 | 84.0 |
| NO _x Rate (lb/hr) | 2.5 | 9.6 | 39.9 | 74.7 |

¹Data from Reference 13.

To select the appropriate fraction of each of the two beds, it is clear that primary attention should be directed at 75 and 100 percent power settings, where the NO_x emission rates are substantially higher.

Optimization of the two beds for these conditions may be conducted by trial designs using the results of Figures 4, 5 and 7. However, comparison of Figures 5 and 7 shows that 100 percent hydrogen mordenite is the preferred combination at temperatures of 507°C and above (75 to 100 percent power setting). For the lower power settings, a combination bed is optimal, of about 50 percent each. However, as will be shown in Section III, a reactor designed for 100 percent power setting with 100 percent hydrogen mordenite is also effective at lower power settings due to the lower total exhaust rate there. It appears that some low level of copper mordenite (perhaps 10 percent) may be desired for the application, but additional data will be necessary to confirm this, as discussed in Section III.

SECTION III

REACTOR SECTION DESIGN

In the low-pressure-drop reactor configuration, the catalysts are crushed to 20/30 mesh. A metal screen of a prescribed size and wire diameter is coated with an adhesive which has been selected and tested by KSE for this service. The crushed catalyst is spread over the adhesive, pressed, and cured at 200°C. With proper application procedures, a surface catalyst layer approximating that of close-packed spheres can be obtained. The inlet fraction could be coated with mordenite and the exit fraction with copper mordenite. The result is a bank of parallel passages coated with highly active catalyst, between which the reacting gases pass.

The resulting parallel-passage reactor (PPR) is far superior to conventional honeycomb low pressure drop modules used conventionally (Reference 2). The PPR is low cost, lightweight, able to be used with mordenite systems, and capable of utilizing any specified fraction of the two catalysts employed. The effect of wire screen size and catalyst size is important, and has been disclosed for an early-generation PPR (Reference 8).

A. REACTOR DESIGN MODEL

In this model, laminar flow between parallel plates with reaction is considered. Several assumptions are made to arrive at a computationally manageable model to describe the physicochemical process of interest. Assumptions are listed below:

1. Isothermal conditions;
2. Constant transport properties;
3. Fully developed laminar, Newtonian flow (i.e., the velocity profile is fully developed at the beginning of the catalytic plate);
4. Changes in the total moles due to reaction are too small to disturb the velocity profile;
5. Pseudo-first-order reaction in nitric oxide at the walls;
6. Velocity normal to flow is zero;
7. Axial dispersion of species is negligible;

TABLE 2. TABULATION OF PPR DESIGN EQUATIONS.

A. Fractional Conversion of NO

$$1 - X_{NO} = \exp(-4K_e X) \quad (5)$$

where

$$X = L/(R)(Re)(Sc) \quad (6)$$

R = one-half gap width

L = reactor length

B. Effective Rate Constant

$$\frac{1}{K_e} = \frac{1}{Nu} + \frac{1}{K_w} \quad (7)$$

$$K_w = k_s \quad R/D_{NO} \quad (8)$$

C. Reactor Pressure Drop

$$\Delta P = \frac{2fU^2 L \rho}{(4R)g_c} \quad (9)$$

U = linear velocity at reactor conditions

D. Friction Factors

$$\text{smooth: } f_s = \frac{0.0791}{(Re)^{0.25}} \quad (10)$$

$$\text{rough: } \frac{1}{\sqrt{f_r}} = 4 \log \left(\frac{4R}{e} \right) + 2.28 - 4 \log \{ 1 + 4.67(4R/(e)(Re)(\sqrt{f_r})) \} \quad (11)$$

e = surface roughness

E. Nusselt Numbers

$$\text{smooth: } Nu_s = 0.00575 (Re)^{0.8} (Sc)^{0.4} \quad Re > 10,000 \quad (12)$$

$$Nu_s = 0.009(Re)^{0.75} (Sc)^{0.33} \quad 3,000 < Re < 10,000 \quad (13)$$

$$\text{rough: } Nu_r = f_r (Nu_s / f_s) \quad (14)$$

$$Nu = 1.88516 + 0.1737 / (1 + 0.53K_w) \quad Re < 3,000 \quad (15)$$

Utilizing these assumptions, an equation for conservation of nitric oxide was developed by Ganti (Reference 9). He developed a general infinite series solution to the partial differential equation, providing the mixing cup concentration of nitric oxide as a function of reactor parameters.

This general series solution is extremely tedious to use to fit data and obtain rate constants. Hence, asymptotic approximations have been developed and validated (Reference 9) for this purpose. The results of the model are presented in Table 2. Additional details on the model and its validation are presented elsewhere (Reference 10).

B. MODEL VALIDATION

The model to be used to describe the behavior of the parallel passage reactor is presented in Equation (5) of Table 2. The model contains one adjustable parameter, the catalytic rate constant. All other parameters in the model are calculable from the fluid dynamics of the system. The rate constant is characteristic of the catalyst used, as determined in Section II for the present application.

Using the procedures of Ganti (Reference 9), the packed-bed-data constants can be converted readily into the coated-surface rate constants of Equations (19), (21) and (22). Although not required by the scope of the present program, approximate data were found in an MS thesis by Medros (Reference 7), which can be used to approximately validate this model.

These data were not collected for the purposes of the process design of the present study. In particular, for experimental convenience, the gaps between the parallel plates were very large and were not equidistant. As a result, the observed space velocities were relatively low. Although the results are therefore not directly applicable to the present program, they are useful to show that the model is capable of representing actual data.

Figures 9, 10 and 11 present data on a parallel-passage reactor in which 1500 ppm of NO_x in flue gas was converted by the mordenite catalyst. The reactor was 2-inches by 2-inches by 8-inches, and contained seven plates of catalyst. Medros (Reference 7) observed that the plates were substantially nonparallel, which allows gas to bypass the catalyst. This, in turn, leads to lower conversion than would be found for parallel plates, with the bias in the data increasing as the conversion increases. Also shown in Figures 9, 10 and 11 are the model predictions for this catalyst. The agreement with the data is excellent, the expected tendency (Reference 7) being to overpredict the actual data at high conversions (Figure 11).

Figures 12, 13 and 14 present a similar prediction from the model for data based upon a dual-catalyst system, corresponding to 50 percent mordenite above 50 percent copper mordenite in a dual-catalyst configuration. These data, also presented by Medros (Reference 7), do not represent the optimal catalyst configuration for the present design. They are simply used to

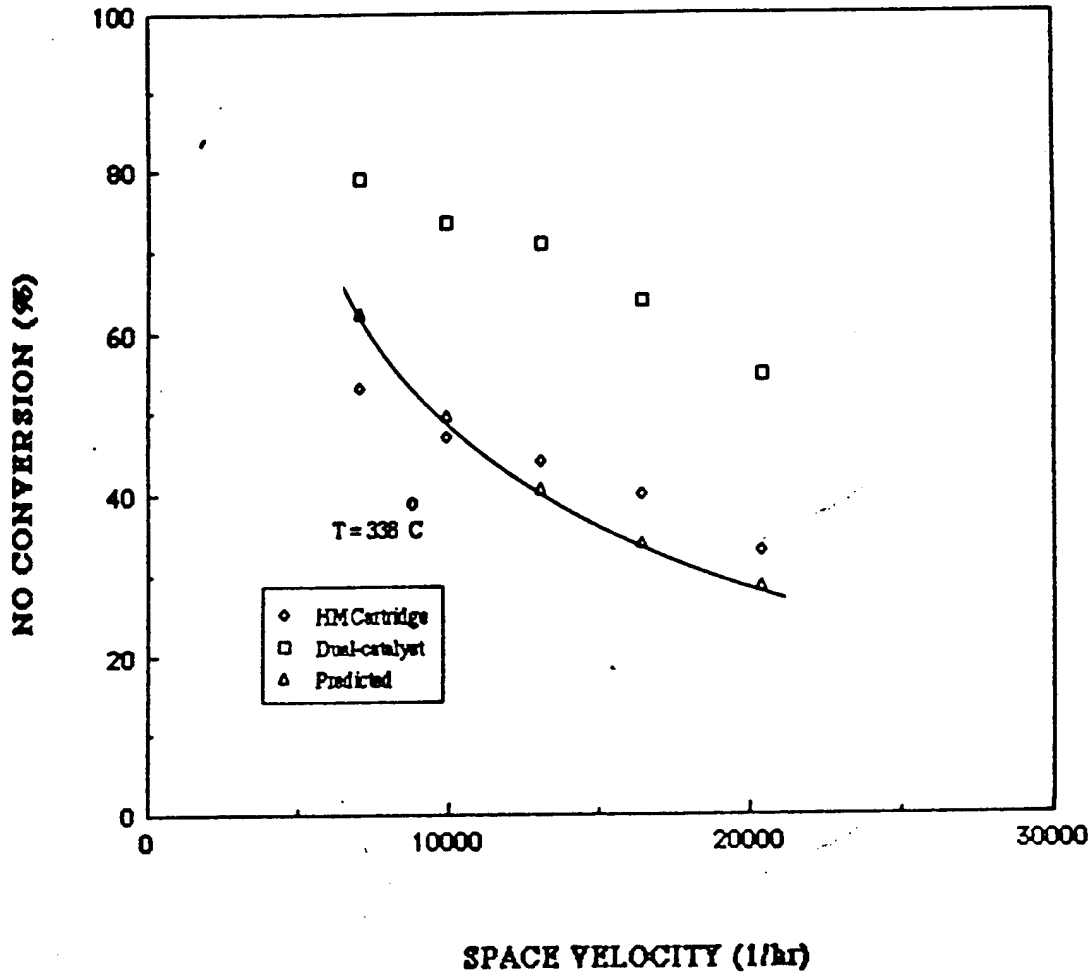

Figure 9. PPR Model Validation for Mordenite Catalyst: Low Temperature; Large, Irregular Gap Spacing.

portray the predictive ability of the model. Again, considering the known defect in the experimental reactor leading to bypassing of the gas, model overprediction at high temperatures (Figure 14) is expected. The overall predictive ability of the model is excellent.

C. REACTOR DESIGN BASIS

In a parallel-passage reactor (PPR) design, the temperature, flow rate, NO_x level, gap spacing between the plates, and the length of the plates are all variables that must be specified, and various combinations of these variables may be selected to provide an effective design. From these combinations, a design must be selected that provides both a target NO_x conversion and an acceptable pressure drop.

Approximately 100 such designs, representing various combinations of variables, were evaluated. An example of such a calculation is presented in Figure 15 for the J79-17G engine. Note that as the gap spacing between the plates is increased from 2-mm to 8-mm, an increasingly longer reactor is required to achieve a specified

NO_x conversion (as expected). Also, the pressure drop required to reach this conversion is lower. Such tradeoffs are typical in this design.

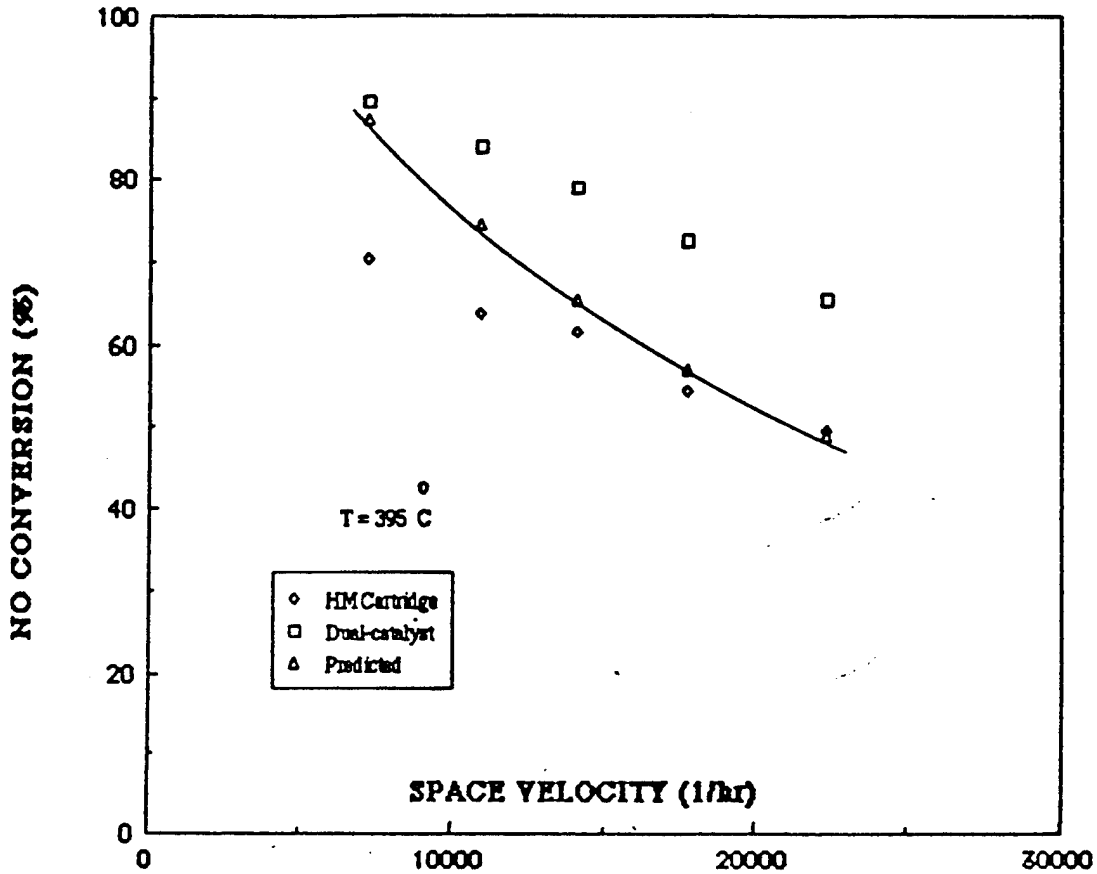

Figure 10. PPR Model Validation for Mordenite Catalyst: Intermediate Temperature; Large, Irregular Gap Spacing.

These preliminary studies determined that the catalyst can be configured as a roll of concentric cylinders of catalyst that can be slipped into each of the muffler tubes on an engine test cell. Because this greatly simplifies the retrofit requirements for test cell applications, this case was selected for the design basis. Alternative designs are presented in Section F, should a conventional rectangular reactor design be preferred.

The muffler design however, must be suitable for a range of conditions corresponding to a range of power setting. Because the base case test cell at Tinker Air Force Base contained fifty-six 3-foot diameter vent tubes from the ceiling of the blast room (Reference 12), the design consisted of 56 identical reactors, each representing a coil of catalyst in one of these tubes. The design basis is given in Table 3.

The afterburner mode assumes that the temperature has been reduced to 609°C by water injection, and, therefore, is not a new case relative to the 100 percent power setting case (T4Q4). The total flow is increased significantly from that case, due primarily to the mass of water injected for temperature control. As will be discussed below, however, the T4Q4 case is not the limiting design case, so the amount of water to be injected is not critical to the total design except that the temperature must be controlled to the range of 600°C to 650°C.

TABLE 3. DESIGN BASIS FOR ENGINE TEST CELL (13)

| <u>Design Case</u> | <u>T1Q1</u> | <u>T2Q2</u> | <u>T3Q3</u> | <u>T4Q4</u> | <u>T4Q4</u> |
|-----------------------------|-------------|-------------|-------------|-------------|------------------|
| No. of Reactors | 56 | 56 | 56 | 56 | 56 |
| Power Setting | Idle | 30% | 75% | 100% | A/B ^a |
| Total Flow, lb/sec | 50 | 108 | 160 | 183 | 200 |
| Temperature, °C | 315 | 314 | 507 | 609 | 609 |
| Inlet NO _x , ppm | 9.5 | 18 | 53 | 84 | 15 |

^a Afterburner operating

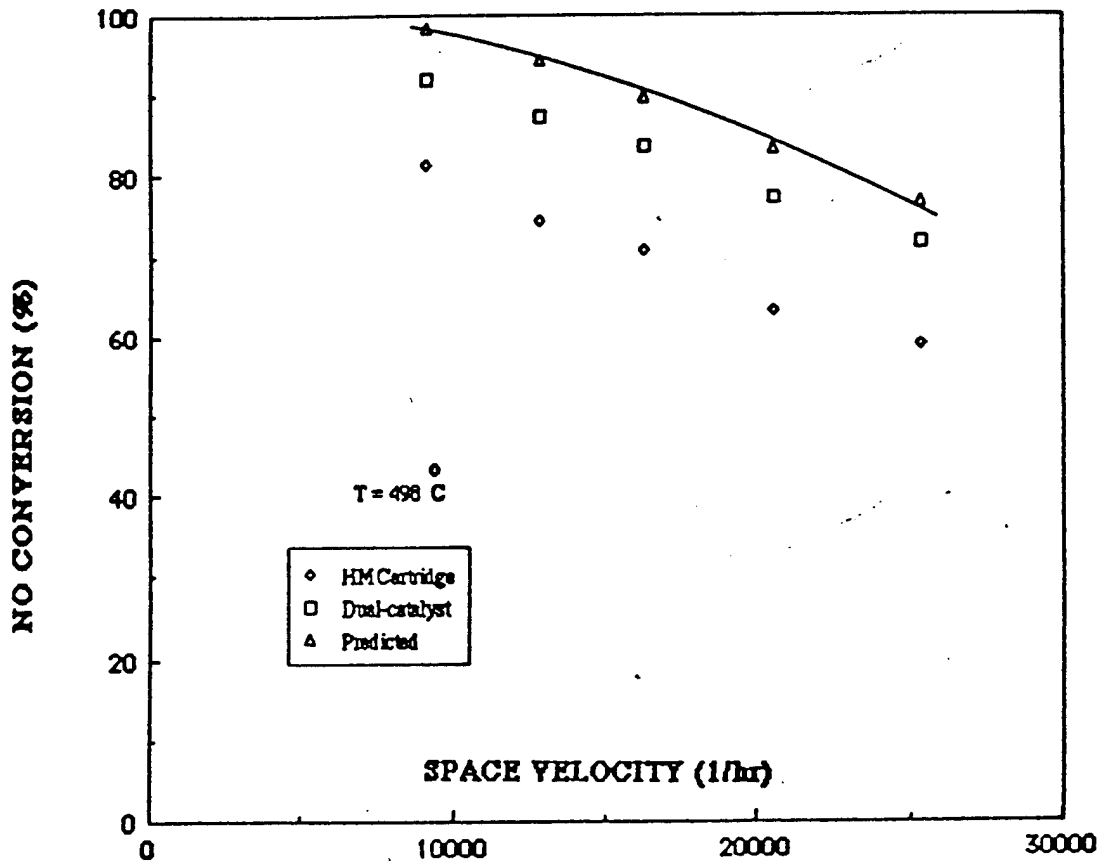

Figure 11. PPR Model Validation for Mordenite Catalyst: High Temperature; Large, Irregular Gap Spacing.

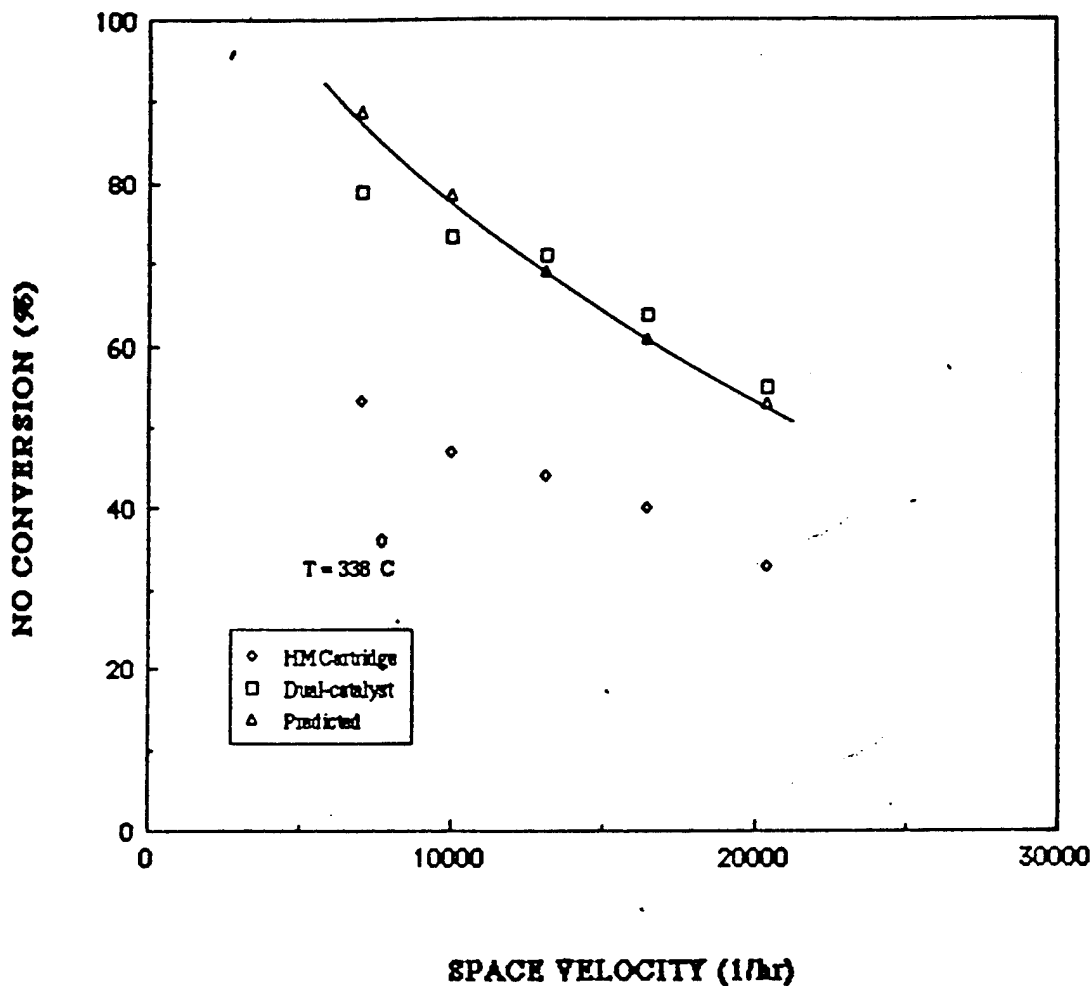

Figure 12. PPR Model Validation for Dual-Bed Catalyst: Low Temperature; Large, Irregular Gap Spacing.

D. BASE CASE DESIGN: ENGINE TEST CELL

From the 100 sets of assumed conditions calculated and discussed above, a gap spacing of 3- to 5-mm was concluded to provide the best tradeoff on reactor length and pressure drop. Figures 16 and 17 present the calculated NO_x conversion and reactor pressure drop for a 3-mm gap spacing (about 1/8-inch).

These figures represent the behavior of each of 56 catalyst coils inserted into the 56 individual vent tubes. Conversations with one of the suppliers of such vent tube

assemblies¹ suggest that the test cell can accommodate a pressure drop of 10 inches of water without generating backflow at the inlet of the ejector tube. Therefore, at the highest pressure drop case of Figure 17 (Case T4Q4), a reactor length of about 33 inches is acceptable. As seen from Figure 16, this predicts 95 percent conversion for all cases except Case T2Q2, which combines a relatively low temperature and high flow. That case exhibits 85 percent conversion, but as shown in Table 1 also has a low NO_x emission rate.

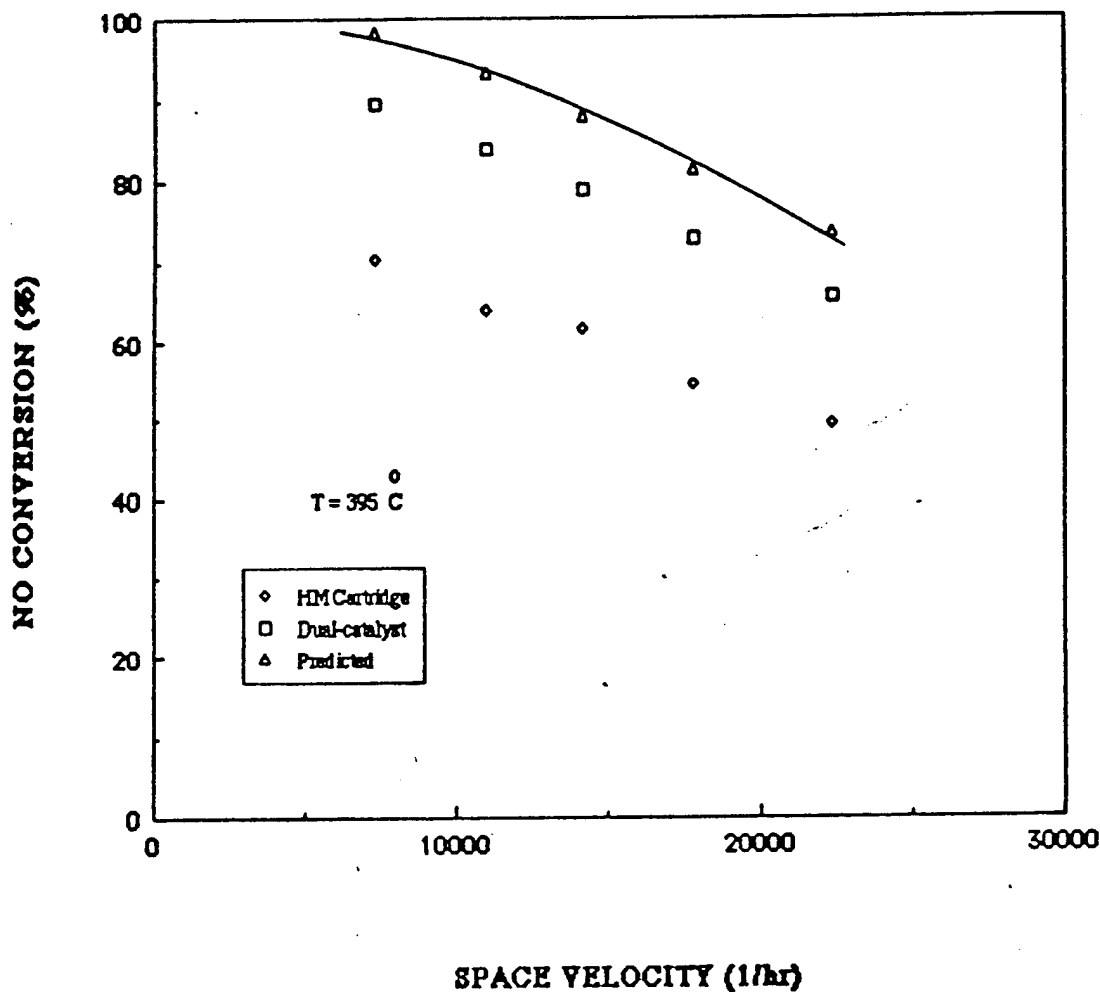

Figure 13. PPR Model Validation for Dual-Bed Catalyst: Intermediate Temperature; Large, Irregular Gap Spacing.

¹Personal Communication with Fred Judd, Aero Acoustics, Jacksonville, Florida, May (1989).

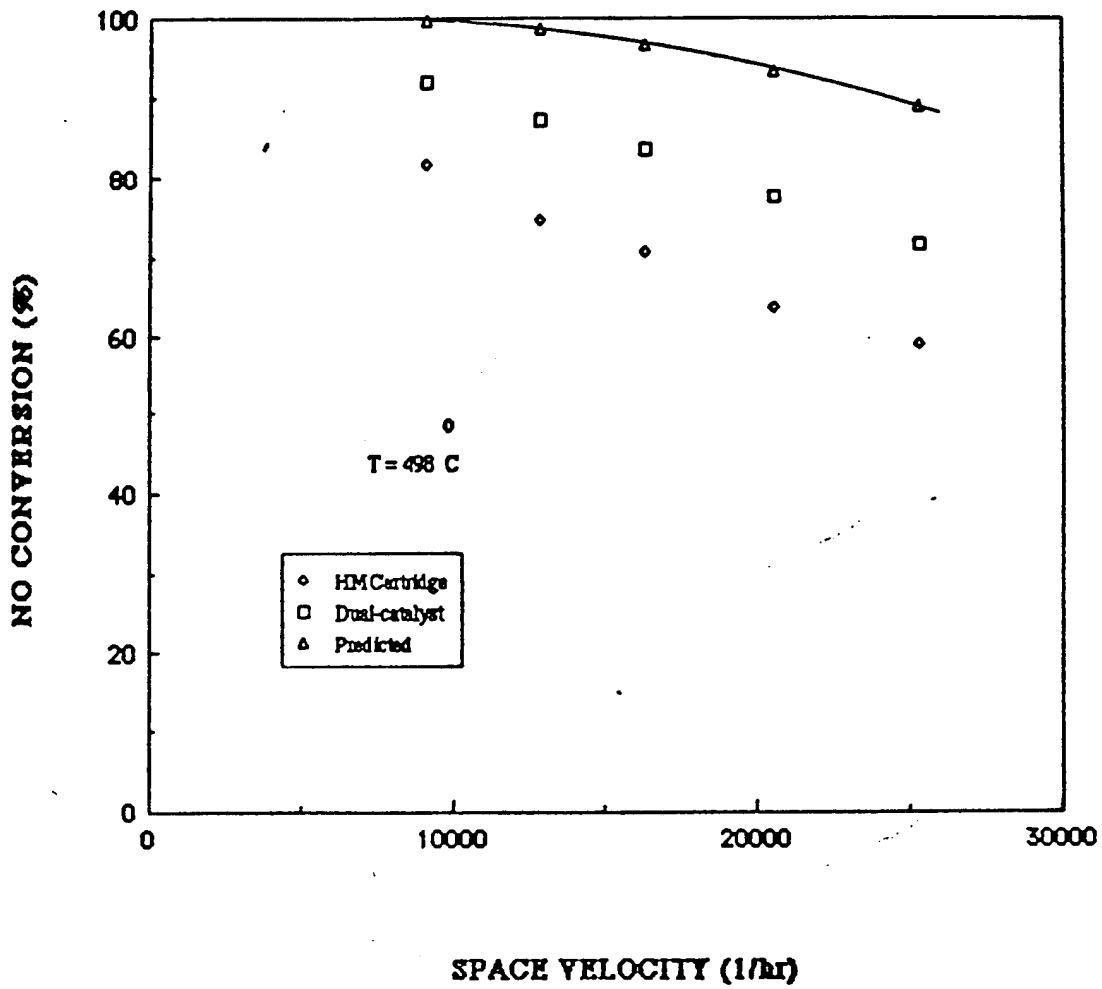

Figure 14. PPR Model Validation for Dual-Bed Catalyst: High Temperature; Large, Irregular Gap Spacing.

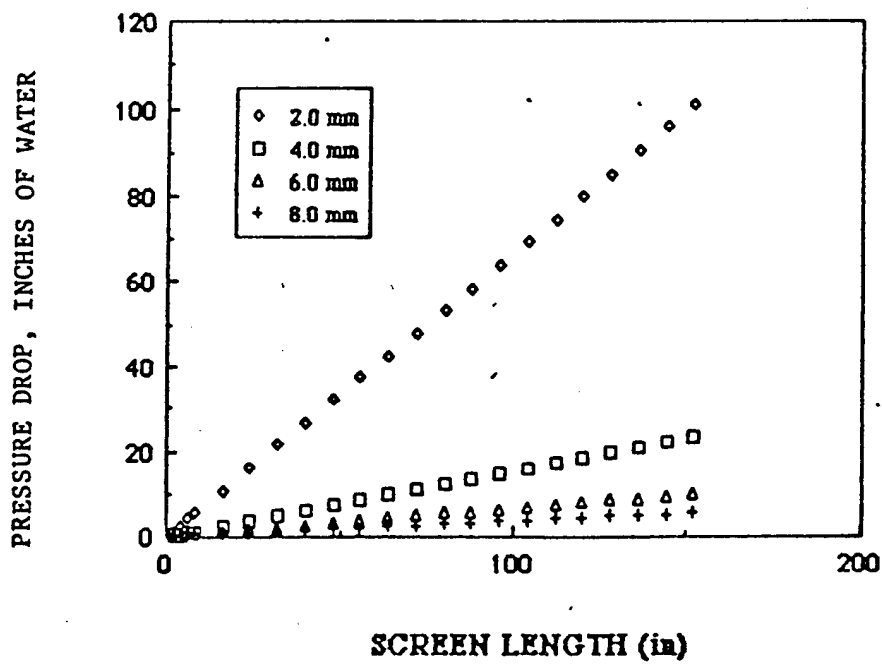
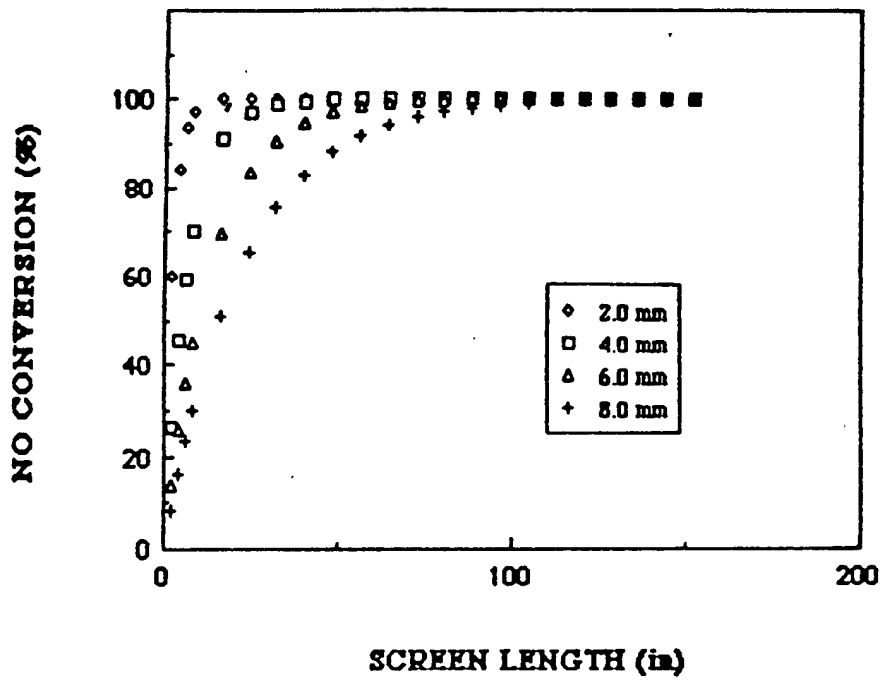

Figure 15. Illustrative Design Calculations for SCR Reactor; 183-lb/sec flow, 593°C, 21- by 21-foot ducts.

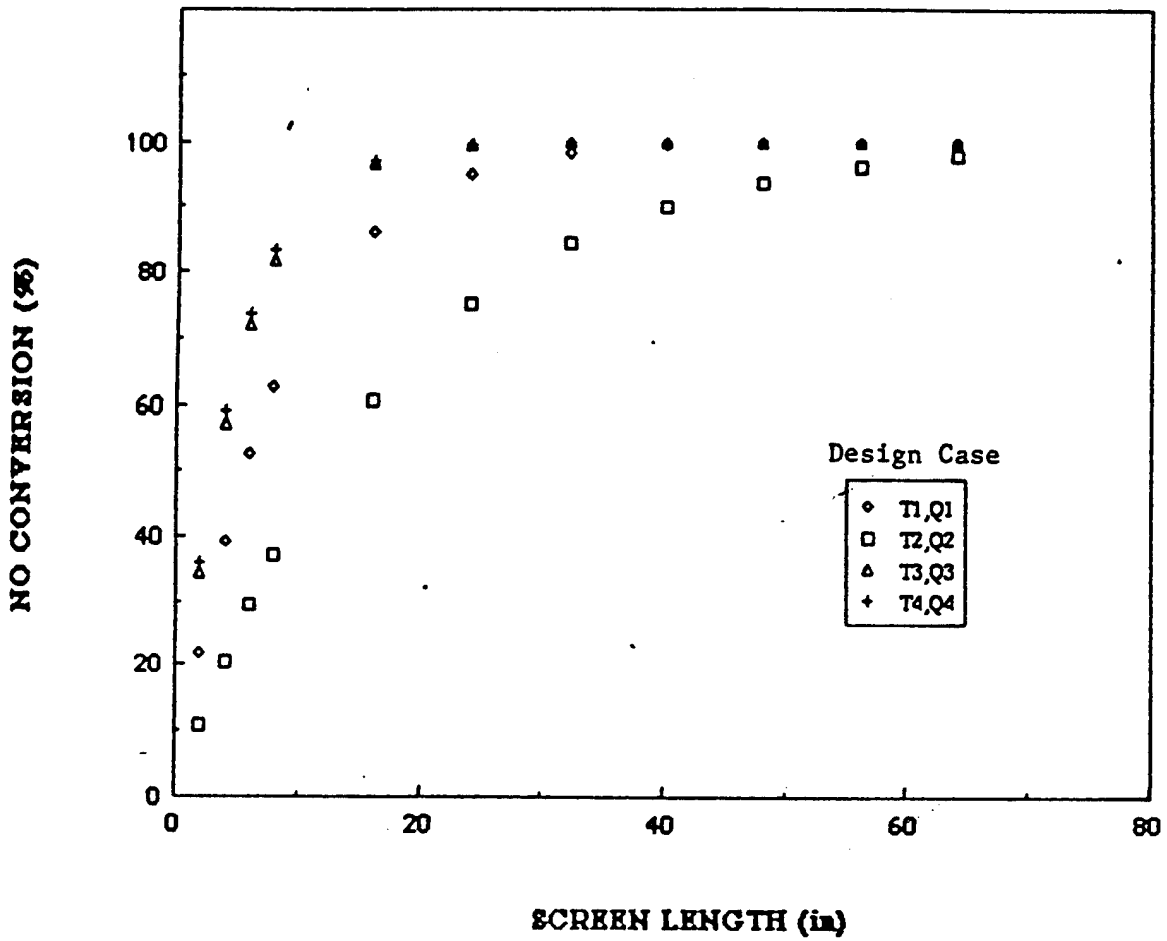

Figure 16. Base Case Reactor Design for J79-17G Engine Test Cell; Mordenite Catalyst for Muffler Vent Tubes, 3-mm Gap Spacing.

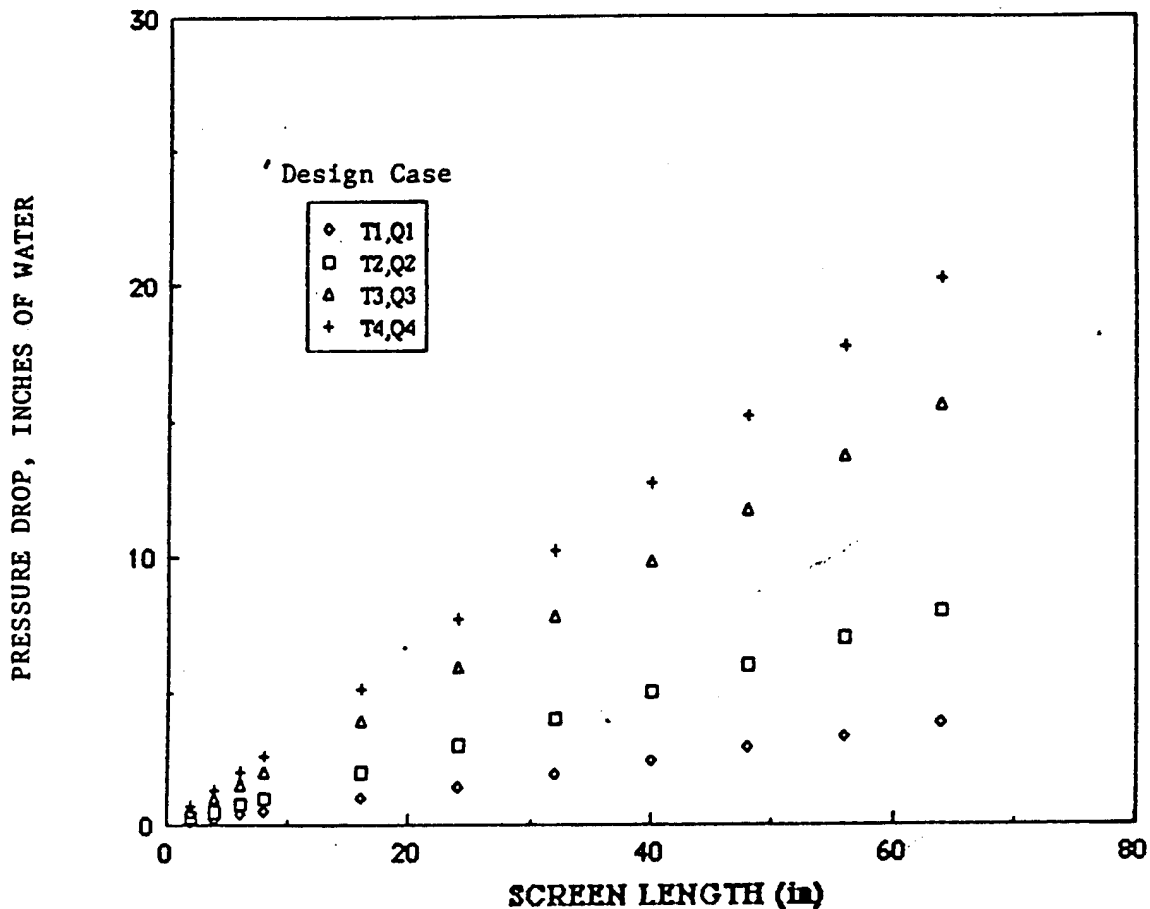

Figure 17. Base Case Reactor Design for J79-17G Engine Test Cell; Mordenite Catalyst for Muffler Vent Tubes, 3-mm Gap Spacing.

E. BASE CASE DESIGN: INCINERATOR

The design basis for the incinerator application is less defined than that of the jet engine test cell, due to the absence of such units in Air Force application. Thus, the design basis was selected to correspond to the von Roll rotary kiln for such applications. This unit is rated at 100 million Btu/hr, producing 40,000 standard cubic feet per minute of gas at 1200°C². Cooling this as by direct water injection to 600°C adds 10 lbs/sec of water, so the total flow becomes 64 lb/sec of gas, or 2760 actual cubic feet per second at 600°C. The inlet NO_x level is 3000 ppm.

For a 10-foot by 12-foot catalyst section, the reactor model predicts reactor performance as shown in Figure 18. It is apparent that a PPR with 4-mm to 6-mm gap spacing will convert 90 percent of the inlet NO_x with a length of less than 50 inches and with a pressure drop of less than 10 inches of water.

² Personal Communication with Fred Sigg, Van Roll, Inc., Atlanta, Georgia, April (1989).

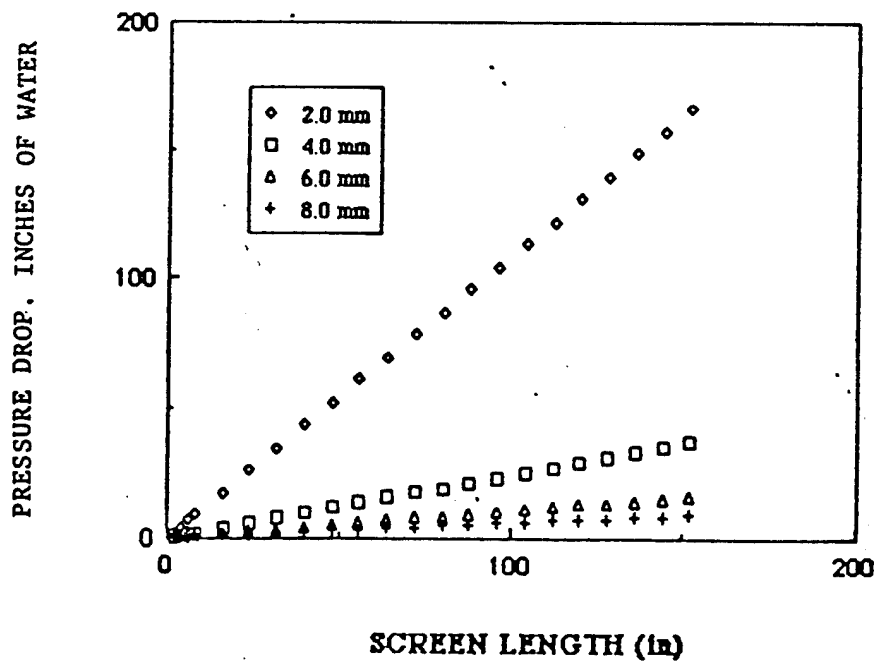
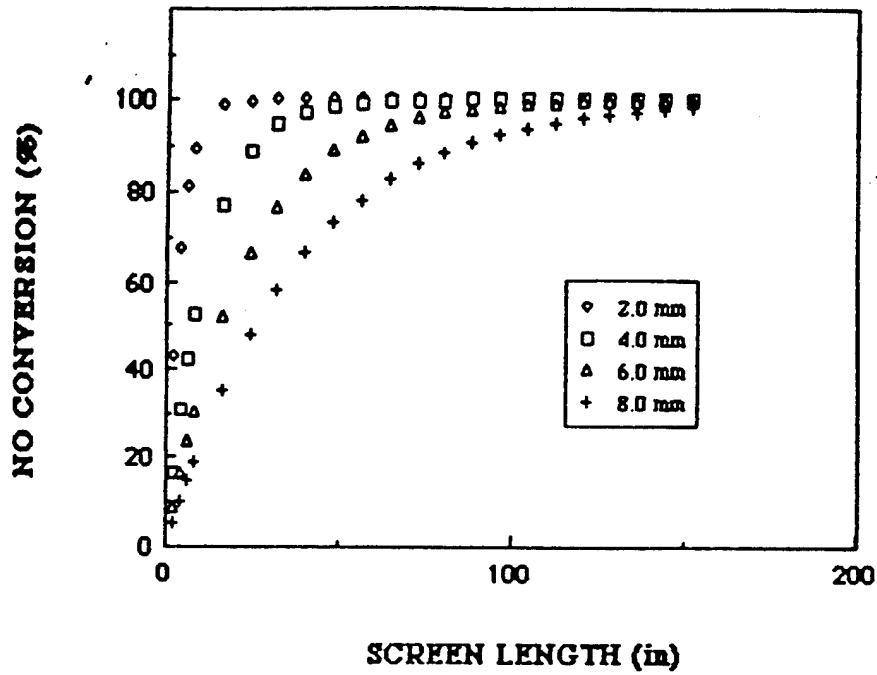

Figure 18. Base Case Incinerator Reactor Design; Mordenite Catalyst, 593°C.

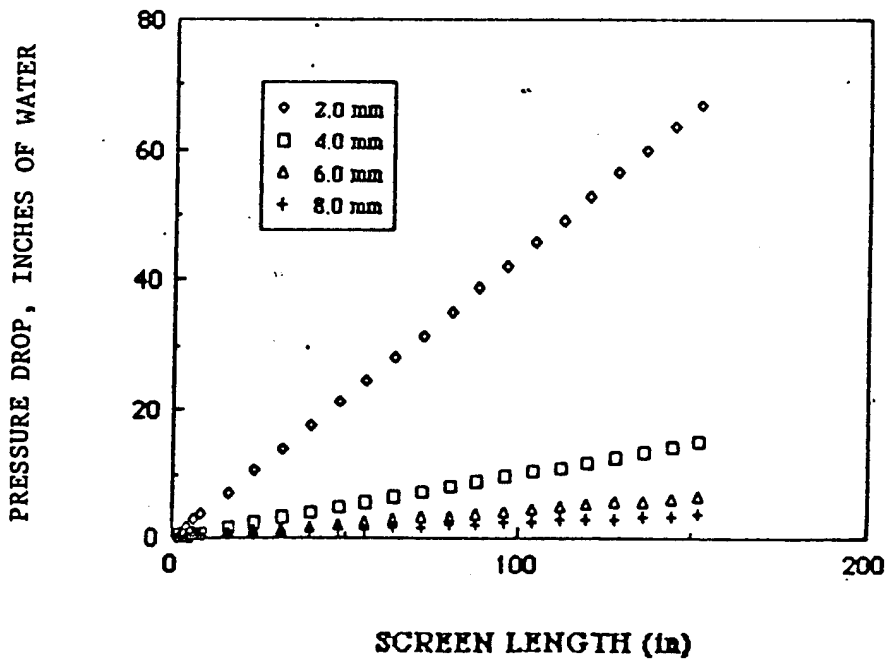
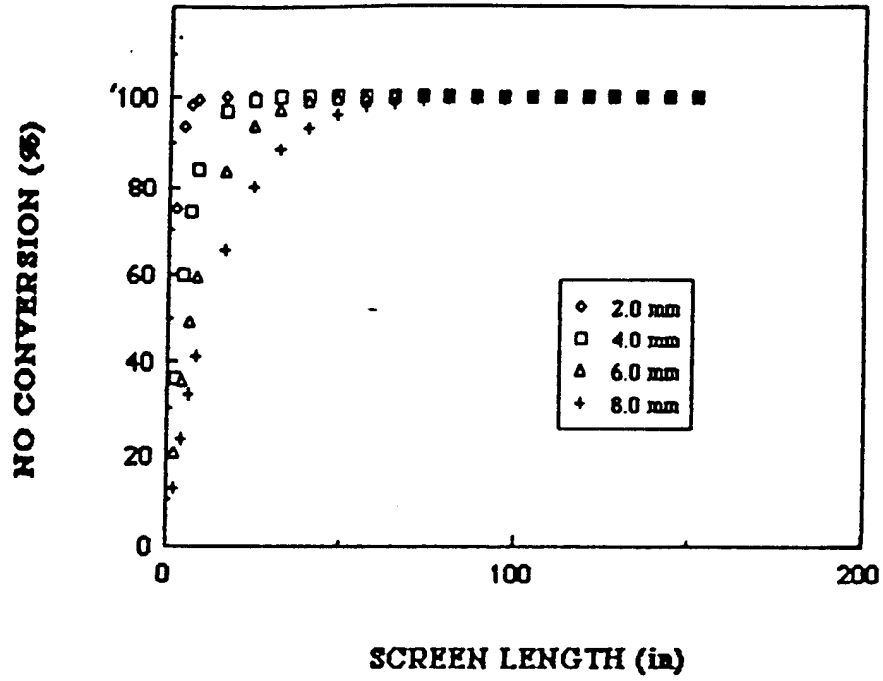

Figure 19. Expanded Gap Spacing Incinerator Reactor Design; Mordenite Catalyst, 593°C.

F. ALTERNATIVE DESIGNS

As discussed in Section III.D, the base case design for the J79-17G engine is characterized by relatively low exhaust flow rates of up to 200 lb/sec and relatively high temperatures of up to 609°C. The catalyst design performed very well under these conditions, using about 90 percent HM catalyst above 10 percent CuHM catalyst.

For many other engine applications, such as the TF33-P3, the system is characterized by higher exhaust flows and lower temperatures. Examples are shown in Table 4 (13).

TABLE 4. EXHAUST CONDITIONS FOR TF33-P3 ENGINE

| <u>Power Setting</u> | <u>Air Flow, lb/sec</u> | <u>Outlet Temperature, °C</u> |
|----------------------|-------------------------|-------------------------------|
| Idle | 81.2 | 276 |
| 30% | 187.5 | 304 |
| 75% | 285.3 | 380 |
| 100% | 318.2 | 425 |

For those lower temperatures and higher flow rates, it is desired to determine if a coiled catalyst system which is slipped into the existing muffler tubes on the test cell will be sufficient. Figures 20 through 23 present the results of design calculations based on 333 lb/sec of exhaust gas, at 260°C, 315°C, 373°C, and 434°C, respectively.

Figure 20 demonstrates that 90 percent conversion can be achieved using a copper mordenite catalyst length of about 30 to 40 inches and a design gap spacing of 3- to 4-mm. The pressure drop across the catalyst is less than 10 inches of water as designed. Since this temperature condition corresponds to the Idle power setting of Table 4, the air flow will be less than the assumed value of 333 lb/sec, so an even shorter bed would suffice.

Comparing Figures 21 through 23 to the entries of Table 4, it appears that a 25-inch bed length will be ample for the TF33-P3 engine at all power settings.

These results, in combination with those of Section III.D, indicate a common design is available for the entire size range of engines. It consists of a 20-inch layer of mordenite catalyst upstream of a 25-inch layer of copper mordenite catalyst, with 3-mm gap spacing, coiled and slipped into each of the exhaust muffler tubes.

An alternative design was evaluated for these cases, in which the catalyst was configured in a separate layer in the exhaust zone between the augments and muffler tubes. This offers the advantage of expanding the cross section available for flow to a 33-foot by 33-foot size, instead of inserting the catalyst coil in each of the muffler tubes.

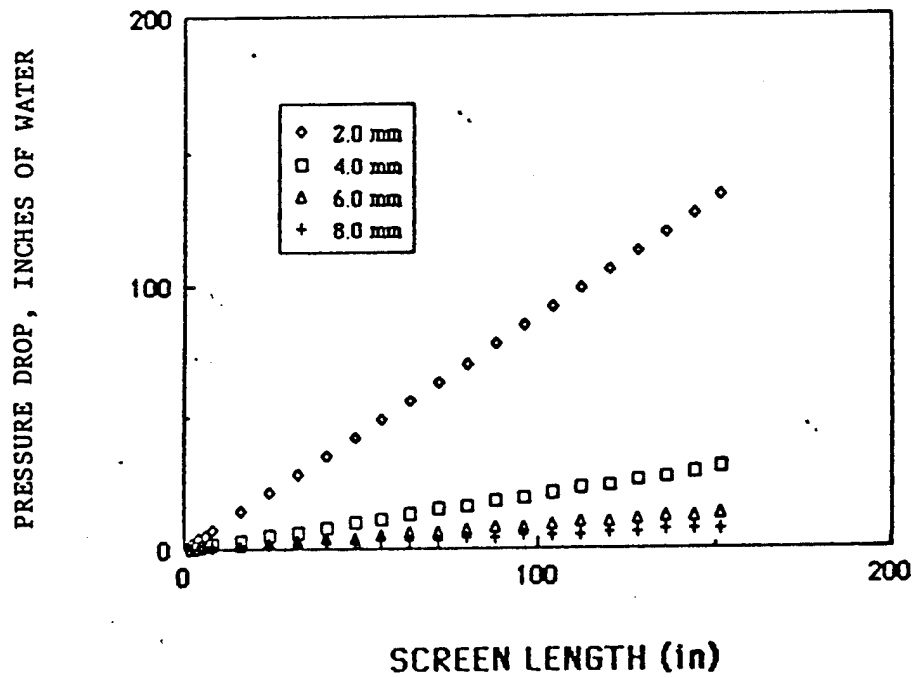
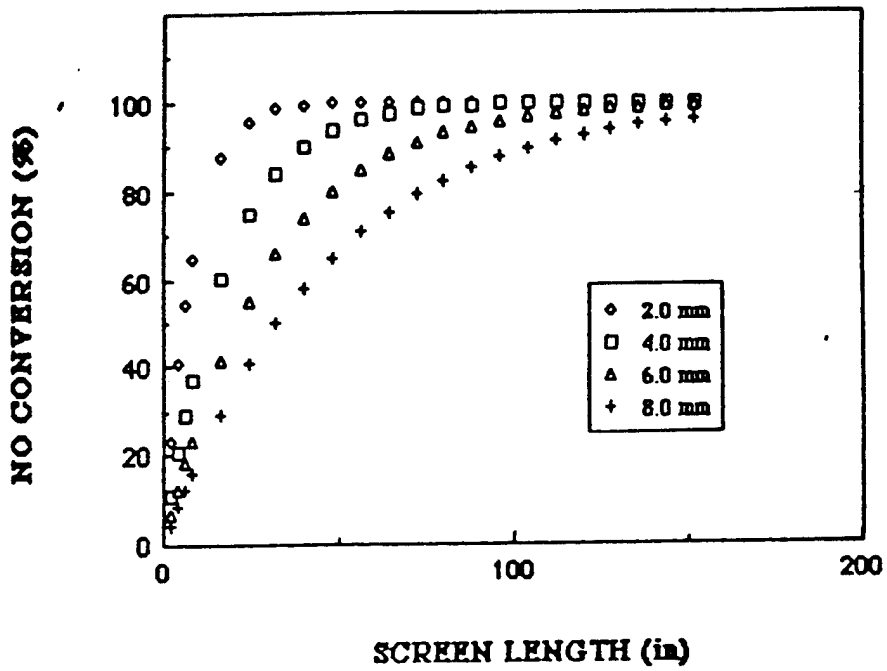

Figure 20. Alternative Reactor Design for TF33-P3 Engine Test Cell: 260°C, Copper Mordenite Catalyst in Muffler Vent Tubes.

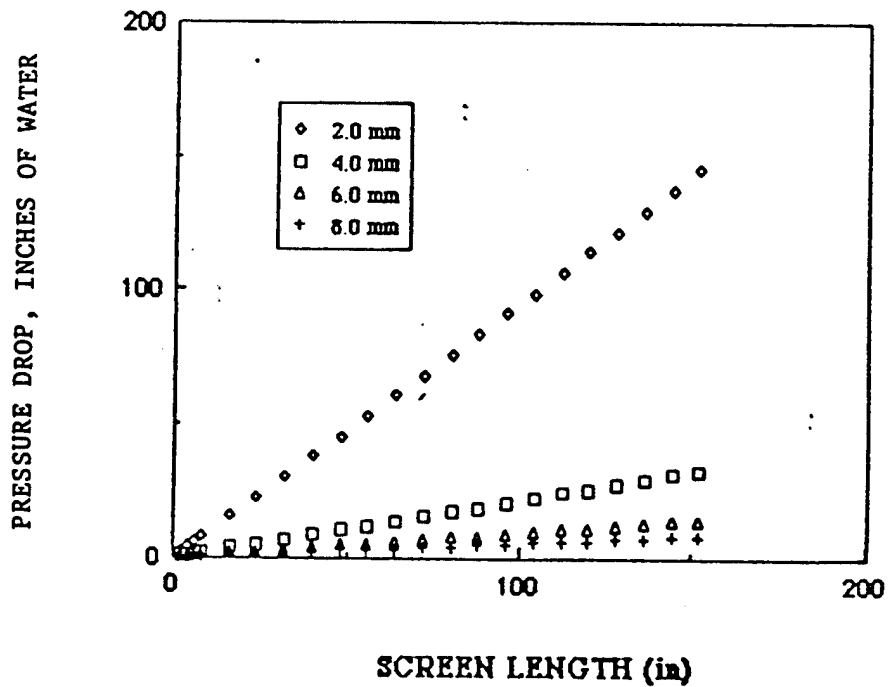
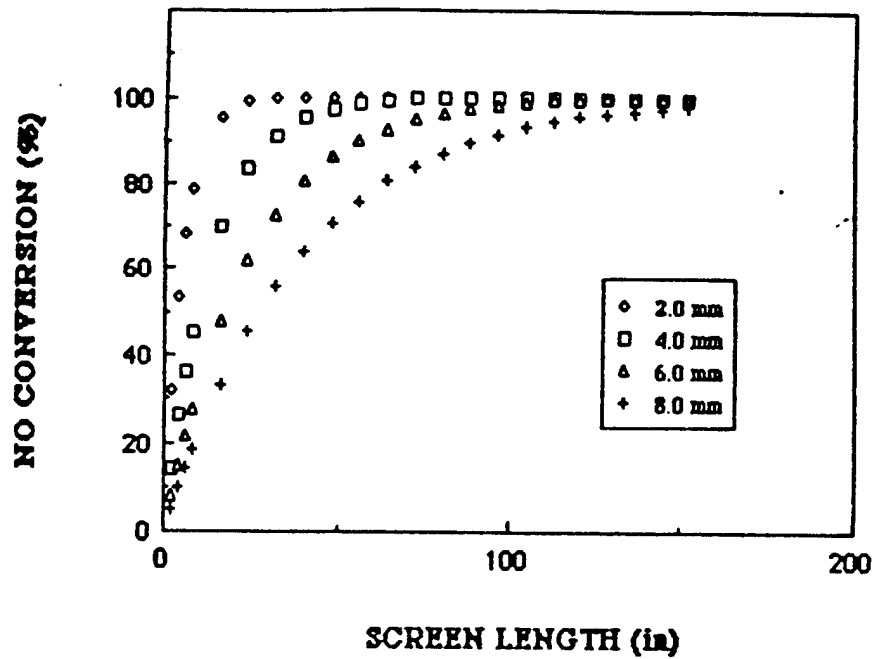

Figure 21. Alternative Reactor Design for TF33-P3 Engine Test Cell: 315°C, Copper Mordenite Catalyst in Muffler Vent Tubes.

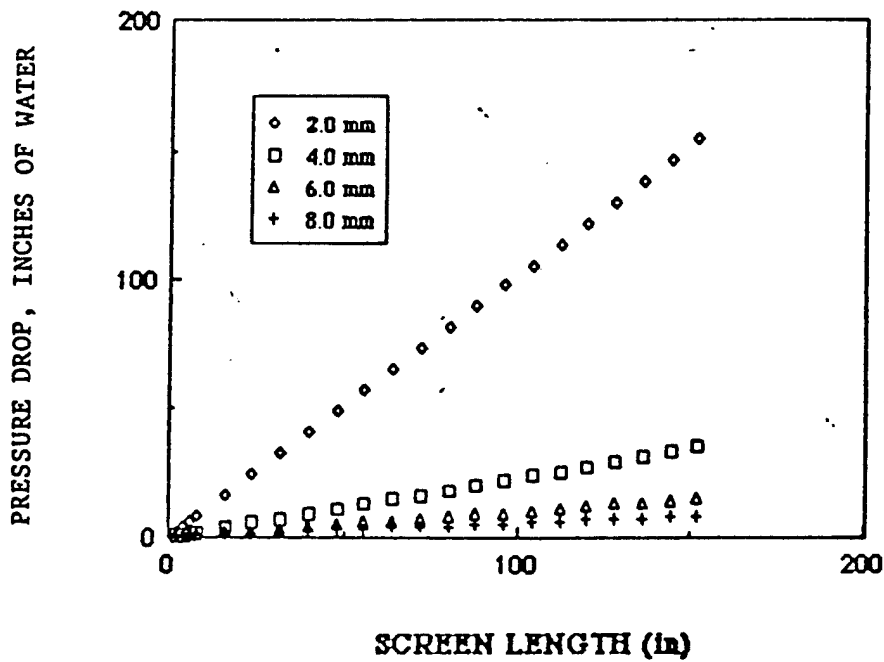
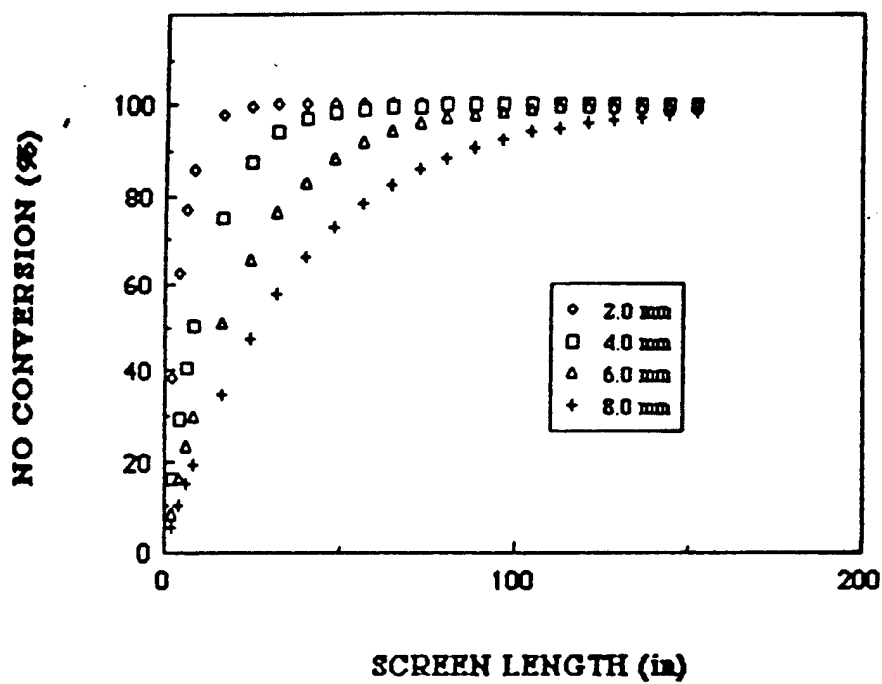

Figure 22. Alternative Reactor Design for TF33-P3 Engine Test Cell: 373°C, Copper Mordenite Catalyst in Muffler Vent Tubes.

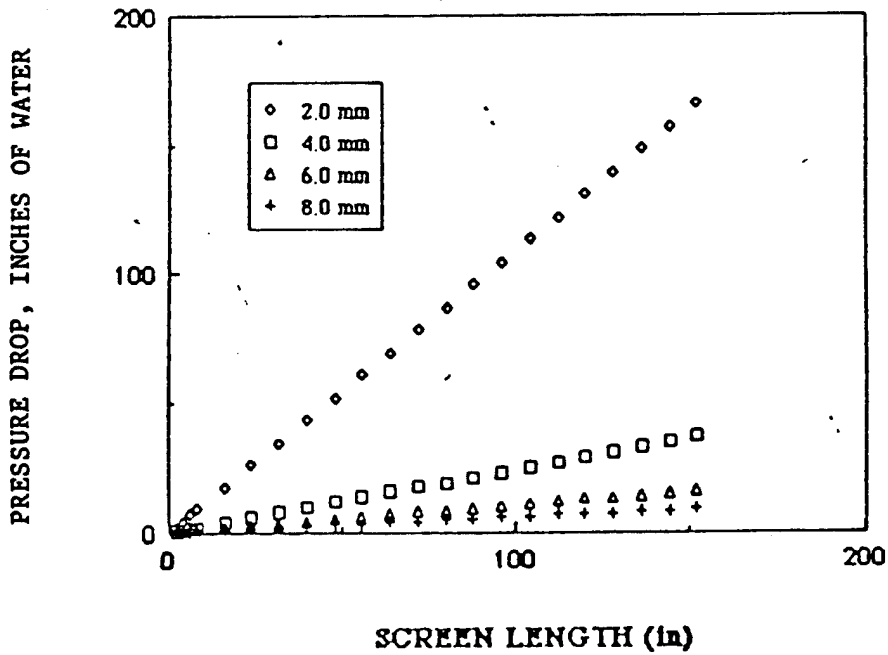
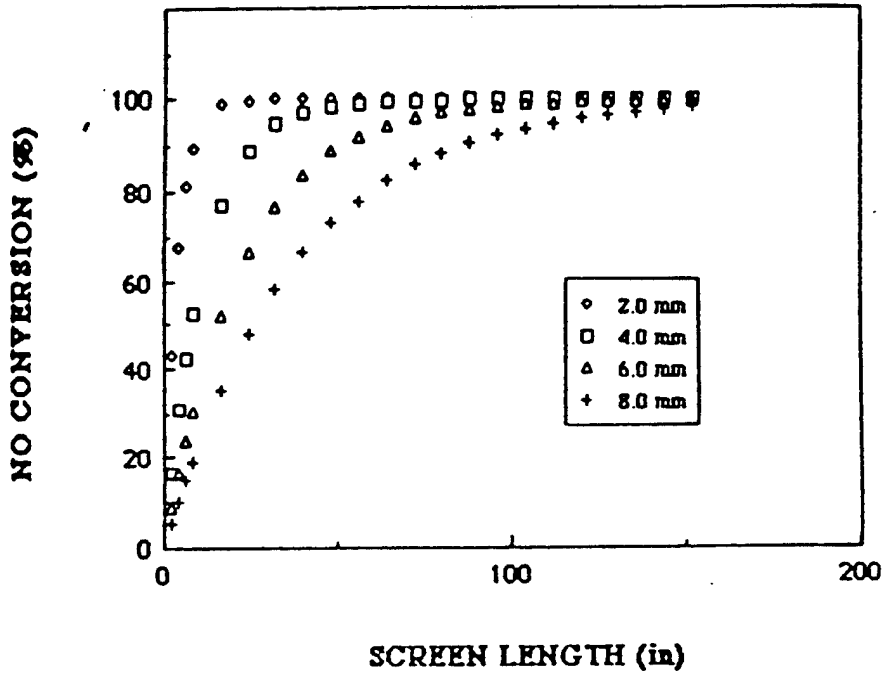

Figure 23. Alternative Reactor Design for TF33-P3 Engine Test Cell: 434°C, Copper Mordenite Catalyst in Muffler Vent Tubes.

It suffers the disadvantage of adding a new element to the exhaust chamber, at higher cost.

The results of the design calculations for this case are presented in Figures 24 through 28, at temperatures from 371°C to 593°C. All calculations assume a mordenite catalyst and a total flow of 333 lb/sec.

It is apparent that the system takes advantage of the selectivity of the mordenite catalyst, in requiring no cooling below about 650°C. Furthermore, the catalyst is sufficiently active that a bed depth of 5 to 25 inches is sufficient, depending upon temperature, with much less than 10 inches of water pressure drop for all designs.

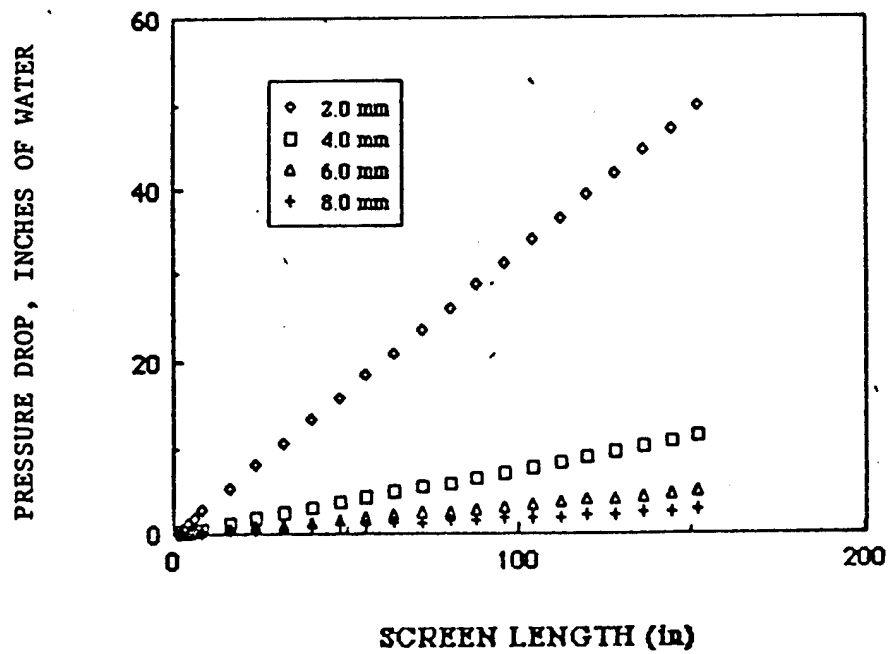
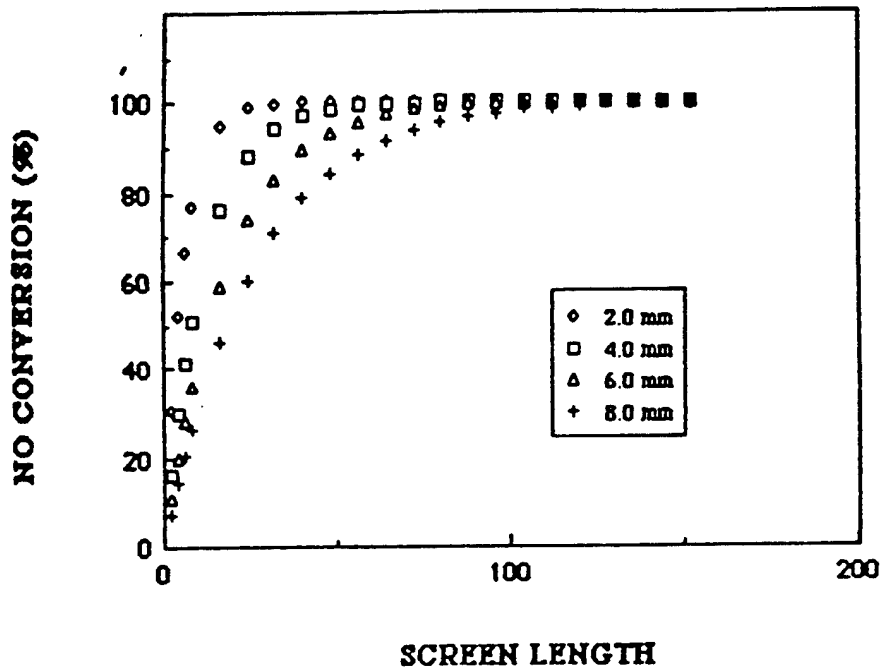

Figure 24. Reactor Design with Catalyst in Flat Bed: 371°C
 Mordenite Catalyst, 33- by 33-foot layer.

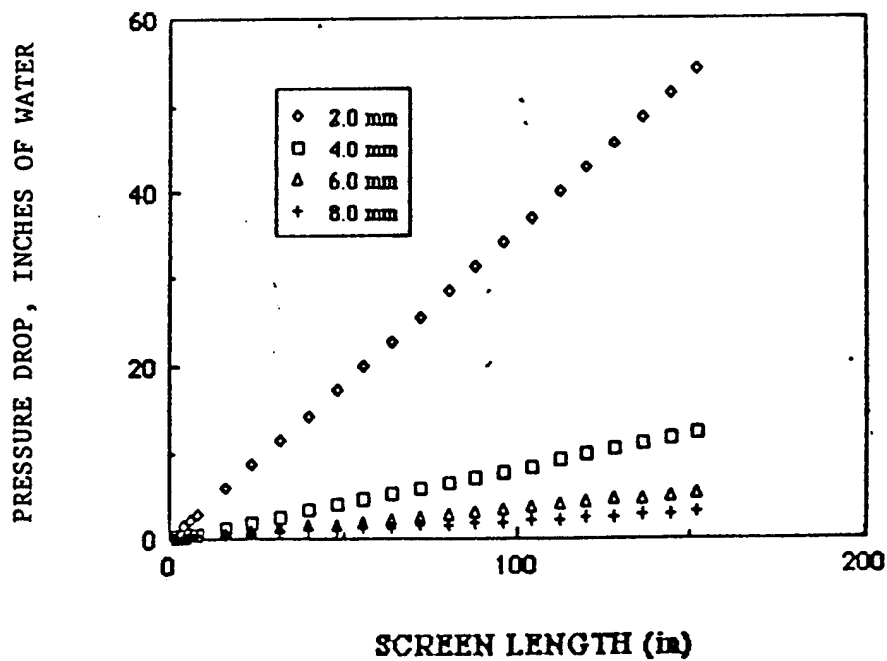
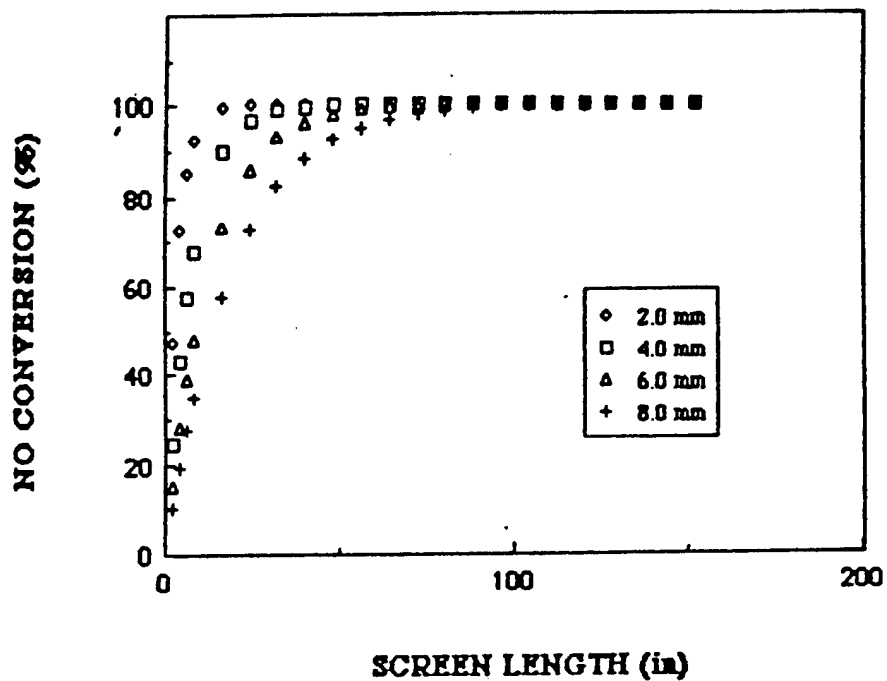

Figure 25. Reactor Design with Catalyst in Flat Bed: 427°C
 Mordenite Catalyst, 33- by 33-foot layer.

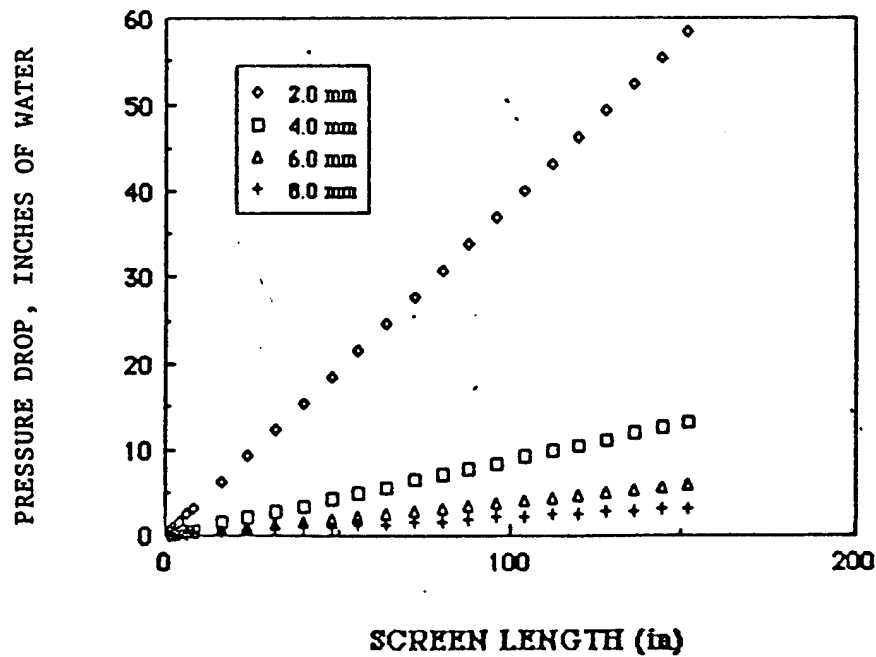
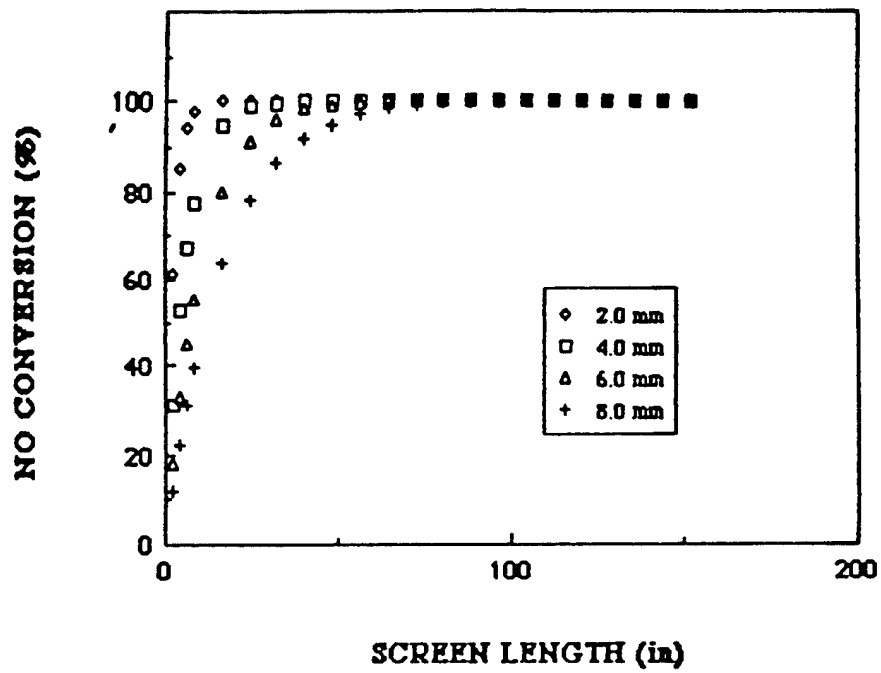

Figure 26. Reactor Design with Catalyst in Flat Bed: 482°C
Mordenite Catalyst, 33- by 33-foot layer.

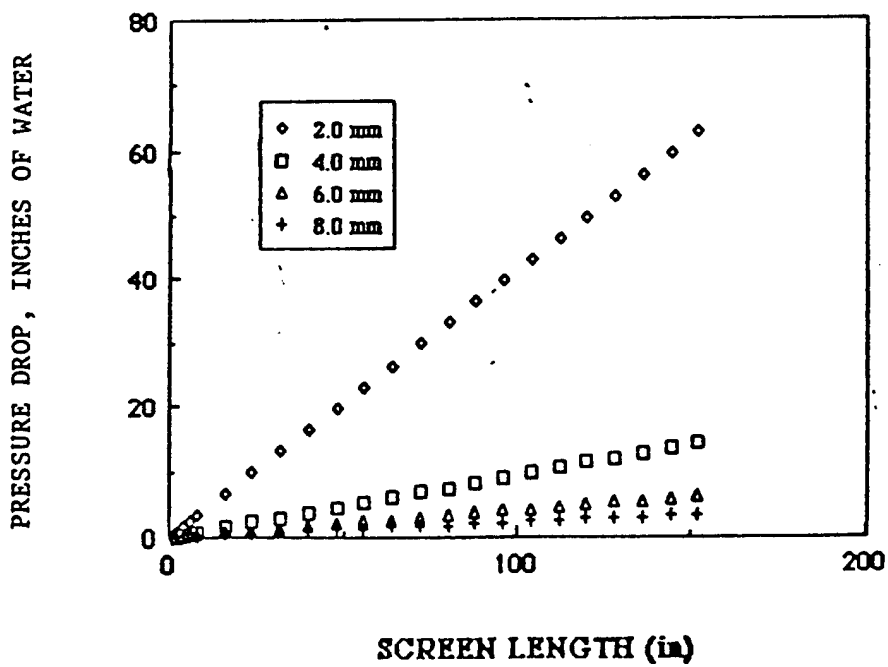
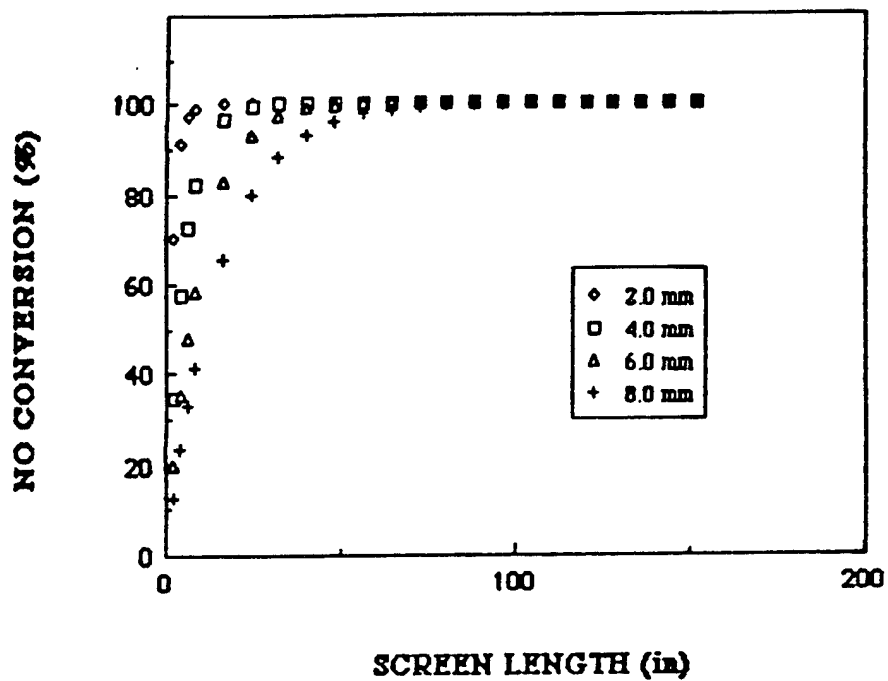

Figure 27. Reactor Design with Catalyst in Flat Bed: 538°C
Mordenite Catalyst, 33- by 33-foot layer.

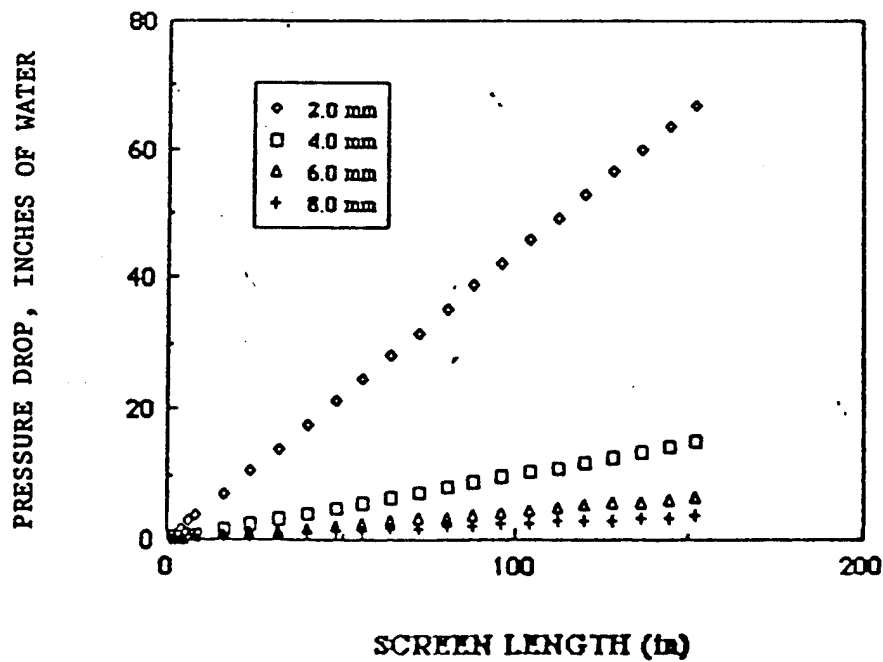
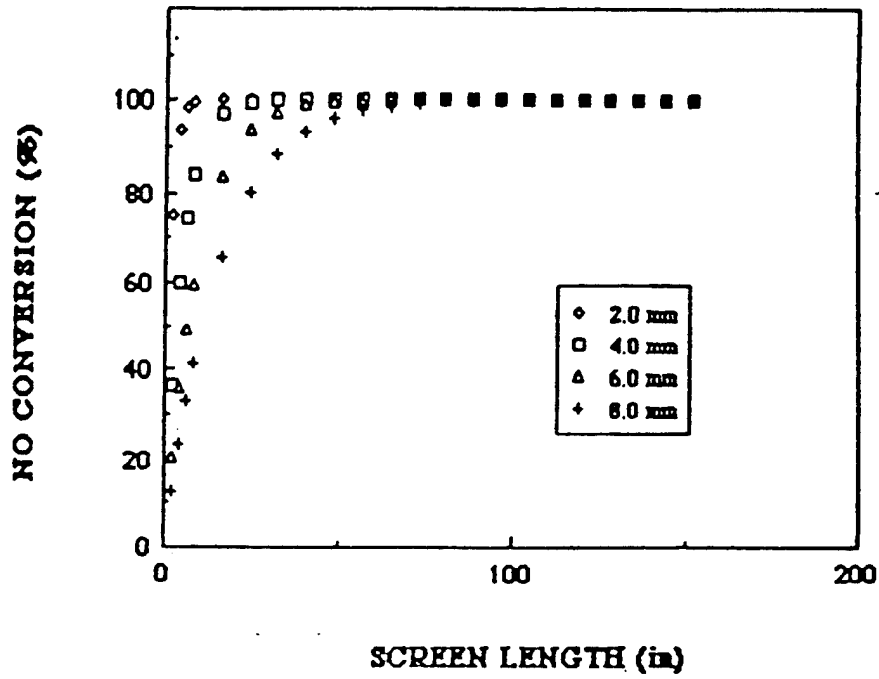

Figure 28. Reactor Design with Catalyst in Flat Bed: 593°C, Mordenite Catalyst, 33- by 33-foot layer.

SECTION IV

OVERALL PROCESS DESIGN

For the schematic flow diagram of the jet engine test cell retrofitted to contain the selective catalytic reduction system for NO_x control, refer to Figure 29, attached.

The inlet edge of the ejector tube has been modified to reduce the secondary air flow ejected into the jet engine exhaust gas by the addition of a front section. In View A-A, the ejector tube is reduced to create an inch of clearance around the end of the mounted engine. A different adaptor will be required for each type of engine tested, and will be remounted for each engine type. The inch clearance allows vibration and ease of mounting, while decreasing secondary air flow to less than 1/10th of the total exhaust gas, and the associated oversizing of the beds and increased pressure drop.

Two exhaust-gas water sprays are shown in View B-B, to control exhaust temperatures below 649°C, protecting the catalyst bed from excessive temperatures, particularly during afterburning power settings. The water spray is injected in a concentric circle within the exhaust cone. The catalyst is stable in moist air.

Ammonia injection is accomplished by a similar concentric ring. Flow of the ammonia will be designed to match the profile of NO_x in the ejector tube. Once the injection distribution is set, the ammonia will remain proportional to the NO_x level in the downstream system, should the NO_x not be evenly distributed across any later cross section of flow. Additional mechanical details are presented later.

Emergency exhaust blowers are provided to ventilate the engine compartment, if necessary, should any upset condition lead to ammonia leakage around the front end of the ejector tube.

Adjustable blockage plates are provided at the end of the ejector tube, to be moved to equalize flow access the vertical exhaust stack. Once these blockage plates have been placed properly, they will not be adjusted again in subsequent engine tests.

An optional secondary preheater is shown on the drawing, to preheat the catalyst bed if necessary for short duration engine tests. Additional data on the rate of heatup of the catalyst bed relative to the duration of the engine test is necessary to ascertain if this preheater is required in practice.

The base case reactor design is shown in the drawing, wherein the catalyst is inserted into the exhaust tubes. In an alternative design discussed in Section III.F, the catalyst can be mounted in a flat plate located between the optional preheater and the exhaust vent tubes.

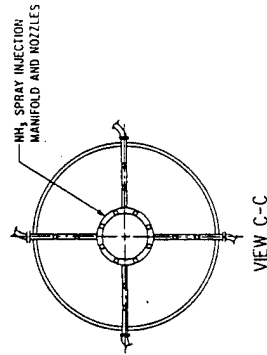
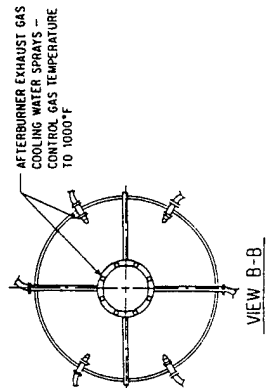
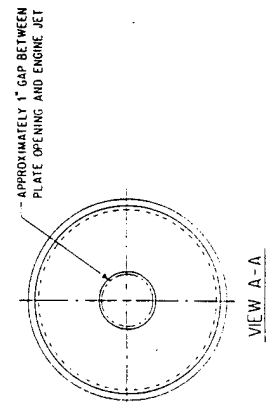
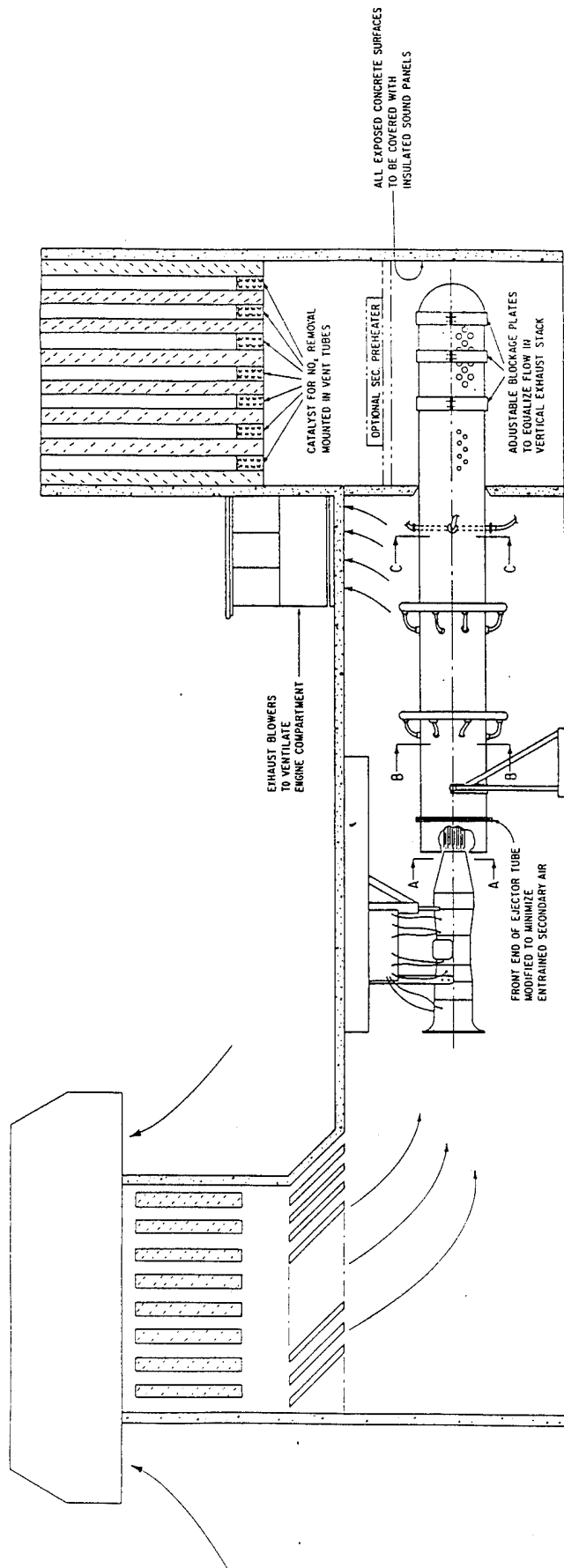

Figure 29. Overall Process Schematic Design.
39

(The reverse of this page is blank)

A. DESIGN BASIS

1. Reactor Inlet Conditions:

a. Turbine Test Cell

| | | |
|--------------|-----------|---------------------------------|
| Mass Flow | 163 | lbs/sec |
| Volume Flow | 7,600,000 | standard cubic feet per hour |
| Gas Velocity | 28 | ft/sec |
| Temperature | 400-600 | °C |

b. Incinerator

| | | |
|--------------|-----------|---------------------------------|
| Mass Flow | 63 | lbs/sec |
| Volume Flow | 2,920,000 | standard cubic feet per hour |
| Gas Velocity | 25 | ft/sec |
| Temperature | 600 | °C |

2. Gas Composition:

a. Gas turbine at 100 percent load

| | | |
|-----------------|----------|----------------|
| Nitrogen Oxides | 250 | ppmv |
| Water | R.H.+2.5 | volume percent |
| Carbon Dioxide | 2.5 | volume percent |
| Carbon Monoxide | 10 | ppmv max |
| Oxygen | 18 | volume percent |
| Nitrogen | balance | |

b. Incinerator at constant load

| | | |
|-----------------|-------------|----------------|
| Nitrogen Oxides | 3000 | ppmv |
| Oxygen | 5 | volume percent |
| Water | 15-20 | volume percent |
| Carbon Dioxide | unspecified | volume percent |
| Nitrogen | balance | |

3. Catalyst Specifications:

| | |
|---------------------|---|
| a. Test Cell | 36-inch diameter x 4 inches |
| Structural Material | 304 Stainless Steel |
| Assembly Detail | wound with 4-mm pitch on 1-inch mandrel |
| b. Incinerator | 2-foot x 2-foot x 4-inch |
| Structural Material | 304 Stainless Steel |
| Assembly detail | stacked 2-mm screens with 4-mm pitch |

B. OVERALL PROCESS DESCRIPTION

Exhaust gases exit the turbine at a rate of 7.6MM standard cubic feet per hour with a mass flow of 163 lbs/sec. The gas travels through the exhaust duct to the entrance of the selective catalytic reduction (SCR) module.

At this point the gas has a velocity of 7 ft/sec and a temperature of 482 to 593°C. In the space of the ejector tube just prior to the wall separation, the NH₃ vapor is introduced into the ejector tube for the purpose of mixing with the exhaust gas so the nitrogen oxides will be reduced effectively over the SCR catalyst.

At the exit of the reactor, the NO_x level will have been reduced by 80 to 90 percent compared with the NO_x concentration entering the control reactor. This can be adjusted by ammonia injection or the addition of catalyst layers.

The concentration of NO_x gas vented to atmosphere is controlled by an interactive SCR control system.

The SCR system consists of the following components:

1. SCR Reactor Section
2. Process Piping
3. Emission monitoring
4. Process controller

An overall general arrangement diagram is shown in Figure 30. A process and instrumentation diagram is shown in Figure 31. These drawings are prepared showing the base case design for the jet engine test cell (see Section III.D). However, they also apply to the alternative design for the jet

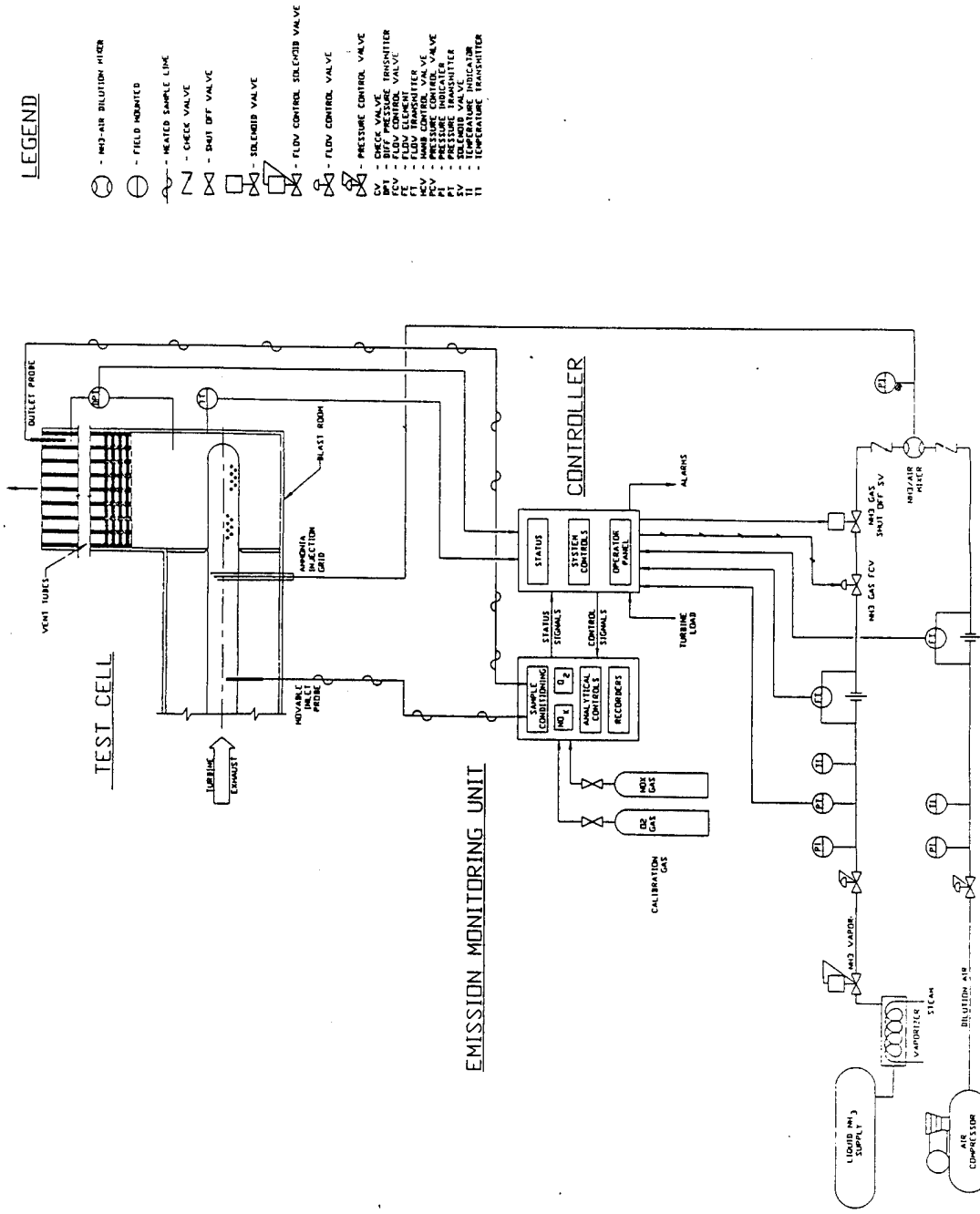

LEGEND

- - MD-AIR DILUTION MIXER
- - FIELD INDICATED
- — — HEATED SAMPLE LINE
- ⌵ - CHECK VALVE
- ⌵ - SHUT OFF VALVE
- ⌵ - SOLENOID VALVE
- ⌵ - FLOW CONTROL SOLENOID VALVE
- ⌵ - FLOW CONTROL VALVE
- ⌵ - PRESSURE CONTROL VALVE
- ⌵ - DIFF. PRESSURE TRANSMITTER
- PT - DIFF. PRESSURE TRANSMITTER
- FV - FLOW CONTROL VALVE
- TV - FLOW TRANSMITTER
- MV - MD-AIR MIXER VALVE
- PV - PRESSURE VALVE
- PI - PRESSURE INDICATOR
- SV - SHUT OFF VALVE
- TI - TEMPERATURE INDICATOR
- TT - TEMPERATURE TRANSMITTER

Figure 30. Overall General Arrangement Diagram.

(The reverse of this page is blank)

engine test cell (see Section III.F) and to the incinerator design (Section III.E), with appropriate modifications to the catalyst location and design.

1. SCR Reactor Section

The reactor section provides conditions necessary to reduce the concentration of NO_x within the exhaust gas. The reactor section consists of the SCR catalyst, an ammonia injection grid to uniformly disperse ammonia vapor into the exhaust stream, a differential pressure transmitter to monitor the pressure drop across the catalyst, and a temperature transmitter to monitor and record the gas temperature in the housing. Two sample extraction points, one upstream and once downstream of the SCR catalyst, monitor the concentration of NO_x . The sample point is equipped with a movable sample probe, allowing determination of the NO_x profile across the ejector tube. Self-regulating, heated samples lines attached to these two extraction points are used to transport samples to the emission monitoring equipment.

For the alternative engine test cell design, the catalyst is moved from the muffler tubes to a location about 4-feet below these tubes. The movable outlet probe is relocated between the catalyst section and the muffler tubes.

For the incinerator design, the mechanical layout is discussed later. The probes are located above and below the catalyst bed, but the other units of Figures 30 and 31 remain the same.

2. Process Piping

The process piping includes the necessary equipment to provide rapid and effective control of ammonia flow to the injection grid. A source of dilution air is required to produce a non-flammable NH_3 mix prior to injection and to enhance mixing in the duct. For the turbine application, expected flow rates for ammonia and dilution air are 1,900 standard cubic feet per hour and 411 standard cubic feet per minute, respectively. The incinerator application is calculated to require 22,800 standard cubic feet per hour of ammonia and 4,950 standard cubic feet per minute of dilution air. A dedicated air compressor is recommended as the source of dilution air.

The ammonia is stored as a liquid in a tank sized for 10 to 30 days of use utilizing two steam vaporizers. The ammonia piping includes the necessary temperature and pressure sensors and transmitters, a flow control valve and an emergency shutoff valve. In addition, isolation valves are strategically located to allow for routine maintenance.

3. Emission Monitoring Unit

The monitoring unit contains the necessary piping, filters, pumps and solenoids to condition the emission sample prior to introducing it into the gas

analyzers. A chemiluminescent NO_x analyzer and an electrochemical oxygen analyzer are used to analyze the emissions. Chart recorders document the emission levels as well as ammonia consumption and the reactor pressure drop. Additional details are presented later.

4. Process Controller Unit

A programmable logic controller (PLC) is used to monitor all required system variables. The PLC uses a status indicator panel and an operator interface panel to show when ammonia injection can be started and to announce any system alarms. Additional details are presented later.

5. Ammonia Management System

Dilution air from an industrial compressor is transported to the process piping skid. Requirements for the air are that it be provided at 30-60 pounds per square inch gauge at a temperature of 16-52°C. The nominal flow rate is 425 standard cubic feet per minute for the turbine application and 4,950 standard cubic feet per minute for the incinerator application. The air is regulated to 20 pounds per square inch gauge. The dilution air passes through an integral orifice plat, which has two taps on each side. These taps are used for a square-root extractor/transmitter, which indicates dilution flow to the PLC. The dilution air then passes through a check valve into the static NH₃/dilution mixer. The static mixer consists of a 1-inch ammonia pipe feeding into a 1.5-inch air dilution tee.

Liquid ammonia is stored in a vessel capable of holding enough ammonia for 10 to 30 days of operation. The tank is equipped with the proper drains and ports required for normal operation. In addition, ammonia vapor detectors are located at several points around and above the vessel to monitor for NH₃ vapor leaks. A steam vaporizer is located in the same area as the liquid tank. This vaporizer is capable of delivering the quantity of ammonia required for the NO_x reduction process. The two vaporizers are sized for the respective applications. An isolation solenoid, located at the beginning of the piping from the control room, can isolate the ammonia vapor at the source as conditions require. The vapor is delivered to the piping skid at a pressure of at least 30 pounds per square inch gauge and a temperature of at least 16°C. The expected flow of ammonia is 1,900 standard cubic feet per hour for the turbine application and 22,800 standard cubic feet per hour for the incinerator. At the piping skid, the vapor is regulated to 30 pounds per square inch gauge. Pressure is monitored downstream of the regulator prior to delivery through the ammonia integral orifice. This pressure is required to calculate ammonia flow. A pneumatic valve is used to control ammonia flow. Downstream of the flow valve, a shutoff solenoid controls absolute shutoff of the ammonia vapor as the PLC determines it necessary. The vapor then enters the static mixer with the dilution air and travels to the NH₃ injection grid.

The injection grid comprises the number of sparger legs needed to properly disperse the NH_3 into the duct stream. Each sparger leg has a hand valve that regulates the amount of ammonia passing into each leg. This design will allow compensation for maldistribution of NO_x in the duct.

6. Sampling and Monitoring System

Figure 32 contains details of the emission monitoring unit. Stainless steel probes are placed at two points of the transport duct. Point one is located in front of the SCR reactor section and point two is located at the stack after the SCR unit. The location of these probes for each design case is detailed above. A heat-traced line is placed between the probe and the sample-conditioning unit. A temperature of 175°C is maintained by regulating heaters with in-line monitors. This heating ensures proper gas analysis by preventing condensation of the sample prior to conditioning.

Drying of sample gas is accomplished in a dual-stage condenser/heat exchanger. The first pass is on the vacuum side of the positive displacement pump. The sample is passed through several spirals of tubing immersed in a coolant bath. A condensate trap is attached to collect condensed moisture. This trap is periodically cleaned by PLC command. A second cooling pass, on the positive-pressure side, removes most of the moisture remaining in the sample.

The sample gas is then cleaned by two levels of filtration. The first is a 10-micron filter designed to remove the large particulates that may have traveled through the sample line with the emission sample. This filter is periodically cleaned by initiation from the PLC. The second stage is a 5-micron coalescing filter, designed to remove smaller particulates and to prevent any carryover liquid from entering the sampling system.

The final stage of conditioning is accomplished by a membrane sample dryer. The dryer consists of a 12-inch tube filled with small capillaries. These capillaries are irrigated with clean, dry instrument air, which is maintained at a lower pressure than the sample. The capillaries are designed to allow moisture to pass from the higher pressure side to the lower pressure side. Only moisture will permeate the membrane. Such membrane dryers are widely used and accepted as a method of final moisture removal.

The emission sample is then introduced into the NO_x and oxygen analyzers. Each analyzer has its own pressure and flow regulating device to assure proper injection of required gases.

Two pumps, one for each sample extraction port, are utilized in this system. By constantly sampling both sample ports and dumping the emission samples until required by the PLC, analyzer stabilization times are greatly shortened.

Calibration gases can be introduced into the conditioning system upstream of all normal sample conditioning. This assures that the emission gases and calibration gases travel the same path to the analyzers.

Whenever the PLC detects a large turbine change, the unit will automatically switch to the inlet monitor and the feedforward process will begin again. This combination of feedforward/feedback assures the quickest response to stack NO_x transients while minimizing NH₃ usage.

7. Process Control

A layout of the process control unit is presented in Figure 33. The process controller is given all necessary inputs to properly evaluate system conditions at all times. The unit may be operated automatically, or selected operator-requested inputs may be carried out by the PLC.

During normal operation, the following conditions must be satisfied for the PLC to allow NH₃ injection to commence:

1. Turbine ON
2. SCR reactor temperature greater than (set point)
3. Dilution flow greater than (set point)
4. Instrument air greater than 40 pounds per square inch gauge.

All four permissives are required for proper SCR operations. Upon meeting the above conditions, an indicator lamp will light to indicate the ability to start ammonia injection. The flow will not begin automatically, because ammonia vapor is a regulated emission and the operator must be aware when the vapor is flowing. Automatic injection is possible but not advisable based upon experience.

While the SCR reactor is enabled for ammonia injection, the sampling system monitors the emission concentrations upstream from the SCR catalyst. This INLET NO_x value is used in the feedforward process of NO_x control. The PLC uses the inlet value, NH₃/NO_x design ratio, and duct

PROCESS GAS SAMPLES

SAMPLE CONDITIONING

GAS ANALYZERS

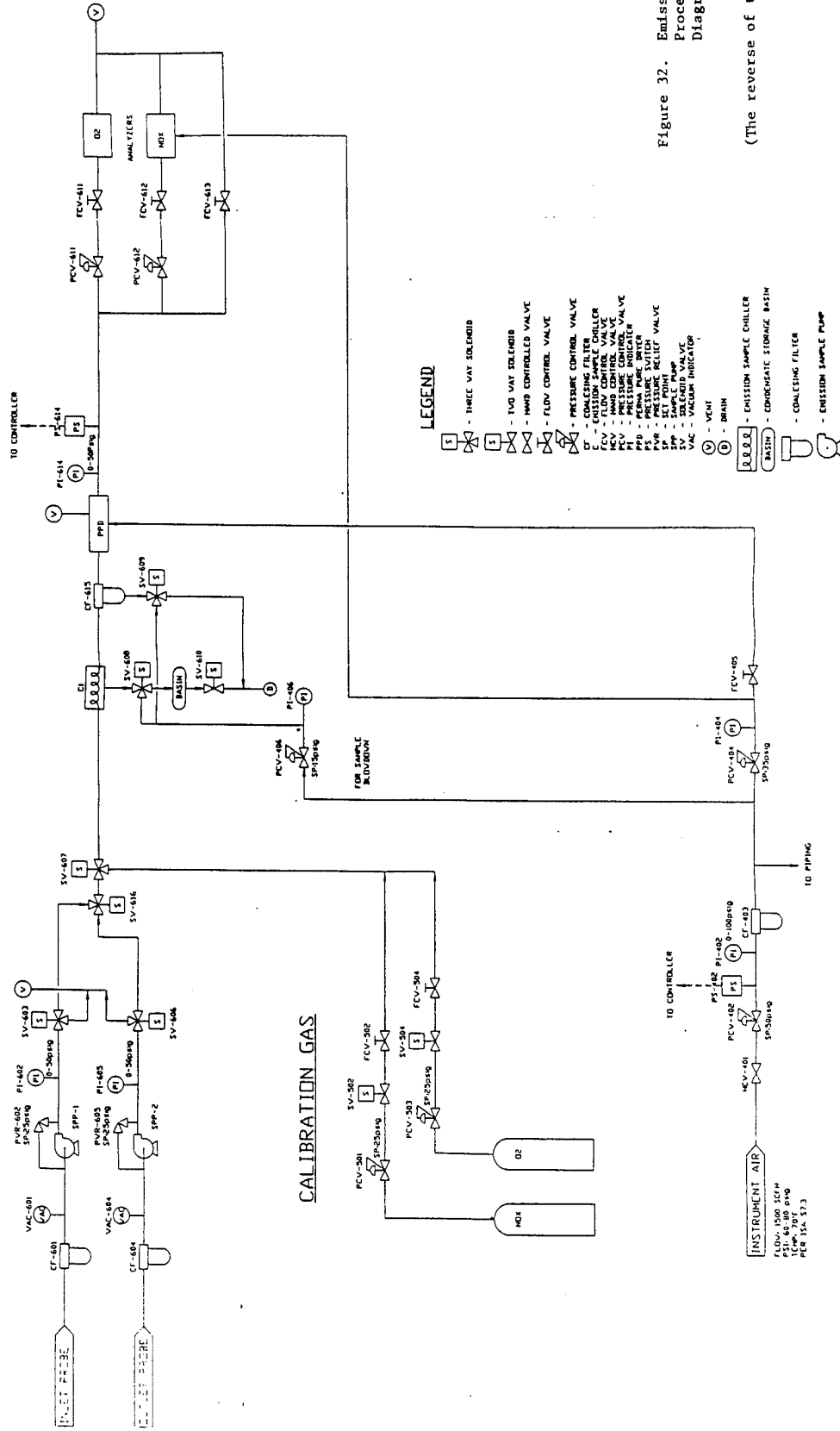
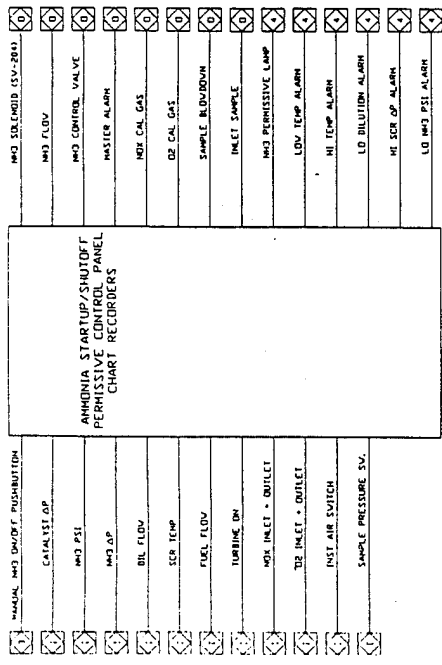

Figure 32. Emission Monitoring Unit Process & Instrumentation Diagram.

(The reverse of this page is blank)

A. PROCESS CONTROLLER



B. BASIC CONTROLLER LOGIC

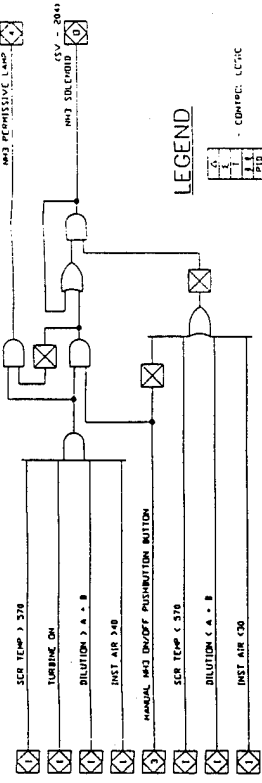

LEGEND

- (with symbol) - CONTROL LAMP
- (with symbol) - CONTROL OUTPUT
- (with symbol) - PUSHBUTTON
- (with symbol) - INPUT
- (with symbol) - AMPLIFIED
- (with symbol) - AND
- (with symbol) - OR
- (with symbol) - INVERTER
- (with symbol) - LEVEL (SHUT)
- (with symbol) - MAIN P.S.V.
- (with symbol) - VOLTAGE TO CURRENT

| | |
|---------------|-----------|
| DILUTION | |
| A - TEST CELL | 500 SCFM |
| B - INCHEATER | 1000 SCFM |

D. AMMONIA FLOW CONTROL

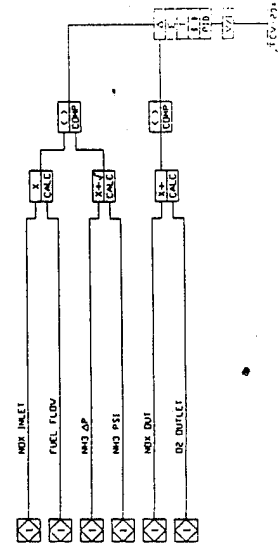

C. EMISSIONS MONITORING UNIT

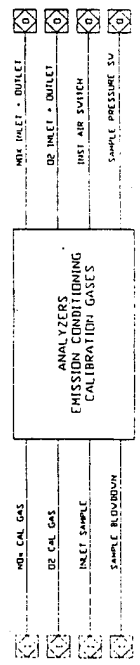

Figure 33. Process Control Unit.
53
(The reverse of this page is blank)

exhaust flow to calculate the required rate of delivery of ammonia necessary to reduce the incoming NO_x concentration to the desired exit concentration.

Upon injection of NH₃, the flow valve will automatically set to the point at which the ammonia injection will reduce the stack NO_x concentration below the permitted level. After ammonia injection starts, the system monitors the outlet emission concentration to fine-tune the ammonia flow. The decision to monitor inlet or stack concentrations, time delay of valve movement, and the amount of valve movement is preprogrammed into the PLC and is based upon field experience. Stack level compliance is limited solely to stabilization periods in the analyzers.

8. Summary of Cost Estimate in 1989 \$:

| | <u>Turbine</u> <u>Test Cell</u> | <u>Incinerator</u> |
|-------------------------------|------------------------------------|--------------------|
| Ammonia Dilution System | \$ 24,980 | \$ 24,980 |
| Sample Monitoring System | 29,740 | 29,740 |
| Process Control | 11,105 | 11,105 |
| Total Miscellaneous | 1,450 | 1,450 |
| Ammonia Vaporizer | 5,000 | 11,000 |
| | <hr/> | <hr/> |
| TOTAL EQUIPMENT | 72,275 | 78,275 |
| <u>Factored Estimate:</u> | | |
| Equipment | 73,000 | 79,000 |
| Engineering | 55,000 | 55,000 |
| Construction | 84,000 | 84,000 |
| Site Preparation | 58,000 | 74,000 |
| Quality Control | 15,000 | 15,000 |
| Project Management | 32,000 | 32,000 |
| | <hr/> | <hr/> |
| SUBTOTAL | 317,000 | 339,000 |
| Contingency 25 percent | <u>79,000</u> | <u>84,000</u> |
| TOTAL | \$ 396,000 | \$ 423,000 |

TABLE 5. EQUIPMENT COST ESTIMATE OF EMISSIONS MONITORING AND CONTROL EQUIPMENT

| DESCRIPTION | TAG | RANGE | ESTIMATED UNIT COST | TOTAL |
|---|------------------------|-------------------------|------------------------|--------------|
| <u>Ammonia/Dilution System</u> | | | | |
| Dilution Hand Valve | HCV-100 | ON/OFF | \$ 550 | \$ 550 |
| Dilution Pressure Regulator | PCV-101 | 0-60 PSIG | 275 | 275 |
| Temperature Indicator | TI-101,201 | 0-200°F | 75 | 150 |
| Pressure Indicator | PI-102,206 | 0-100 PSIG | 80 | 160 |
| Dilution Flow Element | FE-103 | | 2660 | 2660 |
| Flow Transmitter | FT-103 | | 1200 | 1200 |
| Dilution Check Valve | CV-104 | | 70 | 70 |
| NH ₃ Hand Valve | HCV-200 | ON/OFF | 580 | 580 |
| NH ₃ Pressure Regulator | PCV-201 | | 525 | 525 |
| NH ₃ Psi Indicator/Transmitter | PI/PT-201 | 0-100 PSIG | 550 | 550 |
| NH ₃ Flow Element | FE-203 | | 2200 | 2200 |
| NH ₃ Flow Transmitter | FT-203 | | 1200 | 1200 |
| NH ₃ Flow Control Valve | FCV-204 | | 1050 | 1050 |
| NH ₃ On/Off Solenoid | SV-204 | ON/OFF | 400 | 400 |
| NH ₃ Check Valve | CV-205 | | 110 | 110 |
| NH ₃ /Dilution Flow Valve | FCV-304 | | 975 | 975 |
| Y-Strainer | HCV-305 | | 1050 | 1050 |
| NH ₃ /Dil Manifold PSI Indicator | PI-301,306,307,308,309 | 0-50 PSIG | 80 | 400 |
| Sparger Flow Valve | FCV-307,308,309 | | 425 | 1275 |
| Catalyst Temp Transmitter | TT-303 | 0-1500°F | 375 | 375 |
| Catalyst Thermocouple | TC-303 | 0-1500°F | 600 | 600 |
| NH ₃ /Dilution Nozzle | | 100 PIECES | 70 | 7000 |
| Reactor Pressure Drop Xmitter | DPT-302 | 0-100" H ₂ O | 1200 | 1200 |
| I/P Converter | | | 425 | 425 |
| <u>Total Ammonia/Dilution System</u> | | | | <u>24980</u> |

**TABLE 5. EQUIPMENT COST ESTIMATE OF EMISSIONS MONITORING
AND CONTROL EQUIPMENT (CONTINUED)**

| DESCRIPTION | TAG | RANGE | ESTIMATED UNIT COST | TOTAL |
|---------------------------------------|--------------------------------|---------------|------------------------|--------------|
| <u>Sample Monitoring System</u> | | | | |
| Coalescing Filter | CF-601,603,403 | | 225 | 675 |
| Sample Pump | SPP-1,2 | | 650 | 1300 |
| Pressure Relief Valve | PRV-602,605 | 0-25 PSIG | 25 | 50 |
| Pressure Indicator | PI-602,605,406,404,614 | 0-50 PSIG | 80 | 400 |
| Three-Way Solenoid | SV-603,606,607,608,609, 616 | ON/OFF | 75 | 450 |
| Glycol Chiller | CI | | 600 | 600 |
| Pressure Control Valve | PCV-501,404 | 0-50 PSIG | 60 | 180 |
| Two-Way Solenoid | SV-502,504,610 | | 120 | 360 |
| Flow Control Valve | FCV-502,504,405 | | 230 | 690 |
| Pressure Control Valve | PCV-502,504,613,406,402 | 0-60 PSIG | 75 | 375 |
| Hand Control Valve | HCV-401 | ON/OFF | 275 | 275 |
| Pressure Switch | PS-402,614 | 0-100 PSIG | 200 | 400 |
| Vacuum Indicator | VAC-601,604 | 0-30 Hg | 80 | 160 |
| Pressure Indicator | PI-402 | 0-100 PSIG | 80 | 80 |
| Coalescing Filter | CF-615 | | 250 | 250 |
| Membrane Dryer | PPD | | 650 | 650 |
| Pressure Control Valve | PCV-611,612 | 0-30 PSIG | 75 | 150 |
| Flow Control Valve | FCV-611,612,613 | | 275 | 825 |
| NO _x Analyzer | NO _x | | 12000 | 12000 |
| O ₂ Analyzer | O ₂ | | 4700 | 4700 |
| Piping and Tubing | | | 870 | 870 |
| Air Conditioner/Heater | | | 1300 | 1300 |
| Heated Sample Lines | | \$15/ft @ 200 | 15 | 3000 |
| <u>Total Sample Monitoring System</u> | | | | <u>29740</u> |

TABLE 5. EQUIPMENT COST ESTIMATE OF EMISSIONS MONITORING AND CONTROL EQUIPMENT (CONCLUDED)

| DESCRIPTION | TAG | RANGE | ESTIMATED UNIT COST | TOTAL |
|-------------------------------|-----|-------|------------------------|--------------|
| <u>Process Control</u> | | | | |
| PLC Processor | | | 4660 | 4660 |
| Card Cage | | | 360 | 360 |
| Power Supply | | | 560 | 560 |
| Analog Input | | | 1370 | 1370 |
| Analog Output | | | 1370 | 1370 |
| Digital Input | | | 450 | 450 |
| Digital Output | | | 365 | 365 |
| Interface Panel | | | 1270 | 1270 |
| Transformer | | | 50 | 50 |
| Loop Supply | | | *100 | 100 |
| I/O Assemblies | | | 475 | 475 |
| Wire | | | 75 | 75 |
| <u>Total Process Control</u> | | | | <u>11105</u> |
| <u>Miscellaneous</u> | | | | |
| PLC/Emissions Cabinet | | | 1100 | 1100 |
| AC Breaker & Distribution Box | | | 350 | 350 |
| <u>Total Miscellaneous</u> | | | | <u>1450</u> |

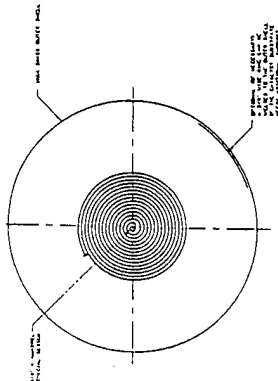

A. CATALYST MODULE
SCALE 1" = 8"

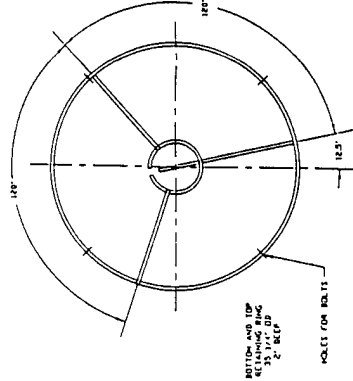

B. SPACER AND RETAINING RINGS
SCALE 1" = 8"

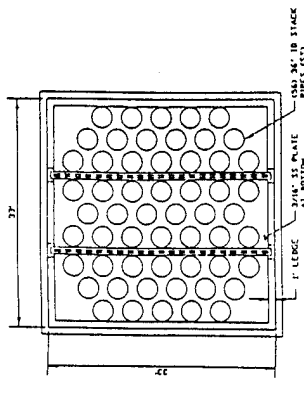

C. STACK PLAN VIEW ASSUMED
SCALE 1/4" = 1'-0"

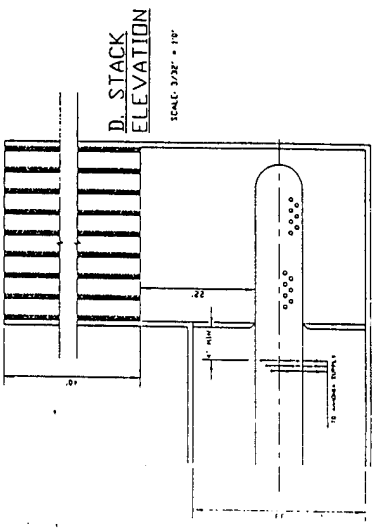

D. STACK ELEVATION
SCALE 3/32" = 1'-0"

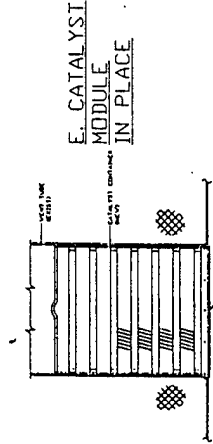

E. CATALYST MODULE IN PLACE

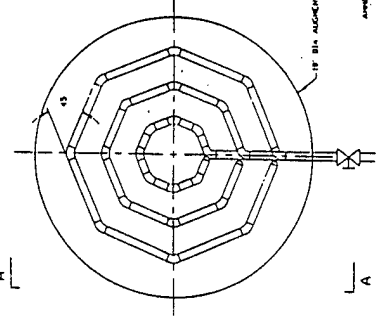

G. AMMONIA INJECTION GRID
SCALE 1/2" = 1'-0"

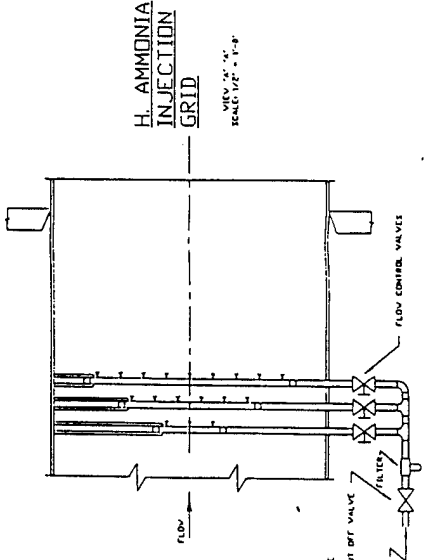

H. AMMONIA INJECTION GRID
SCALE 1/2" = 1'-0"

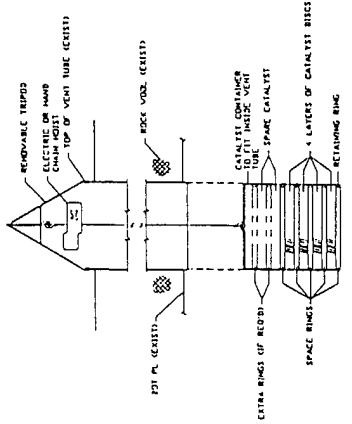

F. CATALYST SUPPORT MODULE AND LOADING MECHANISM

Figure 36. Test Cell.

(The reverse of this page is blank)

C. MECHANICAL DESCRIPTION

1. Turbine Test Cell Mechanical System Description

A detailed mechanical layout for the base case engine test cell design is presented in Figure 34. The mechanical portion of the NO_x abatement system consists of catalyst units and their containers and an ammonia injection grid (AIG). The catalyst units are round discs placed into cylindrical containers that, in turn, are to be located inside the stack vent tubes. The AIG will be installed in the augments tube upstream of the blast room and will comprise three circles or octagons of varying diameters for the purpose of injecting ammonia into the turbine exhaust stream in varying quantities across the cross section of the augments tube.

2. Catalyst Block Design

The catalyst disc is made up of a 4-inch-wide screen, which is continuously wound around a specially designed mandrel until the finished diameter of 36 inches is attained. A thin-gauge stainless steel outer shell is then wrapped around the screen and welded at the seam to retain the disc's shape. If necessary, two 3-inch-wide rings can be attached to the outer shell to provide additional support to the catalyst structure.

3. Reactor Module

The reactor module comprises a cylindrical container and a charge of catalyst discs. The discs are inserted into the container and are supported by retaining rings, which are bolted to the inside of the container. The discs are separated by spacer rings in the module to promote mixing between layers of catalyst.

4. Loading and Unloading Mechanism

The catalyst modules are intended to be brought into the blast room and placed under (or nearly under) the vent tube in which they will ultimately be located. A removable tripod with an electric or hand chain hoist will be placed on top of the appropriate vent tube and the hoist's hook will be lowered through the tube and directed to the appropriate catalyst module. The hook will engage a kinked bar on the module and the unit will then be lifted into place in the bottom of the vent tube. A support ring will bolt to the inside of the vent tube to hold the module in place. Unloading will be accomplished by lowering the hook to engage the kinked bar, lifting the module slightly to take the weight off the support ring, which will then be removed to allow the module to be lowered to the blast room floor.

5. Ammonia Injection Grid

The AIG is designed to take into account the uneven velocity distribution in the augments tube. Three concentric circles of pipe, each with a predetermined number of special spray nozzles on them, will inject ammonia distribution to suit the velocity profile. A filter will be installed on the supply line upstream of the flow control valves to protect the small orifices of the nozzles from clogging. See figure below for a sketch of a typical nozzle, for which all dimensions shown are in inches.

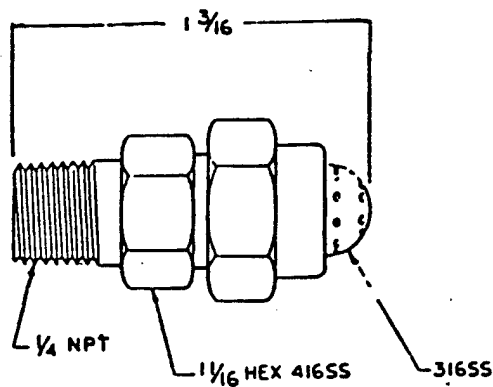

In design temperatures over approximately 550°C the preferred material for the ammonia ejection grid piping is ASTM A31Z TP304 (austenitic stainless steel). There is a possibility that ammonia being injected from the nozzles will come in contact with the stainless steel downstream and be converted to NO_x. This ammonia-to-NO_x conversion is temperature dependent; although it is not expected to be significant, it is a phenomenon that should be considered.

D. INCINERATOR MECHANICAL SYSTEM DESCRIPTION

Detailed mechanical layouts for the incinerator control system are presented in Figure 35. The mechanical portion of the NO_x abatement system consists of a catalyst housing, catalyst panels and an ammonia injection grid (AIG). The catalyst panels are made up of smaller 2-foot square blocks installed horizontally in a portion of the exhaust duct where the flow is directly vertically downwards, as recommended by von Roll, Inc.³. The AIG, which is located above the catalyst, is designed to provide as even a distribution of ammonia as possible over the catalyst area.

³ Personal Communication with Fred Sigg, Van Roll, Inc., Atlanta, Georgia, April (1989).

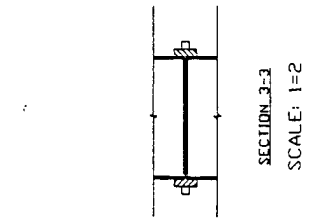

SECTION 1-1
SCALE: 1=2

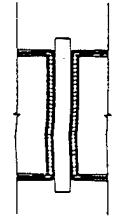

SECTION 2-2
SCALE: 1=2

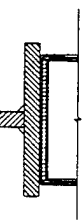

SECTION 3-3
SCALE: 1=2

C. CATALYST PANEL DETAILS

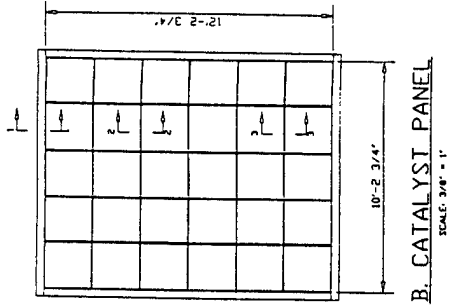

B. CATALYST PANEL
SCALE: 3/8" = 1"

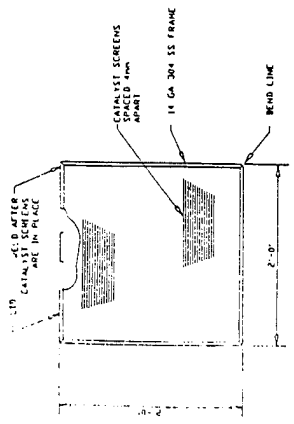

A. CATALYST MODULE
SCALE: 1/8" = 1'-0"

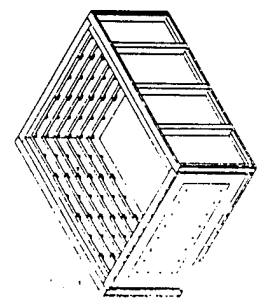

D. CATALYST HOUSING
SCALE: 3/16" = 1'-0"

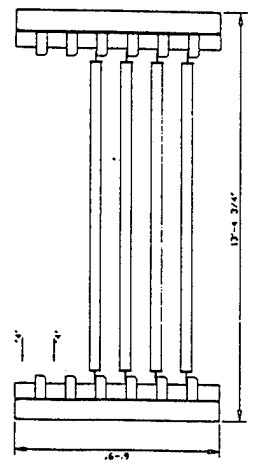

E. TRANSVERSE SECTION
SCALE: 1/2" = 1'-0"

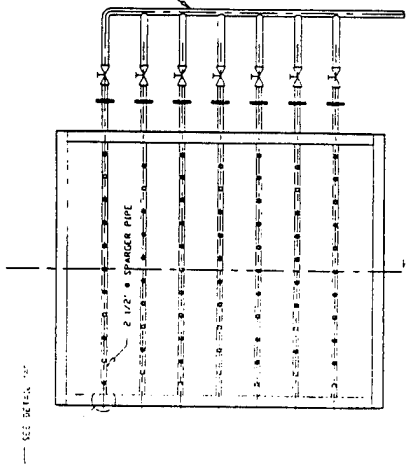

F. AMMONIA INJECTION GRID
SCALE: 3/8" = 1'-0"

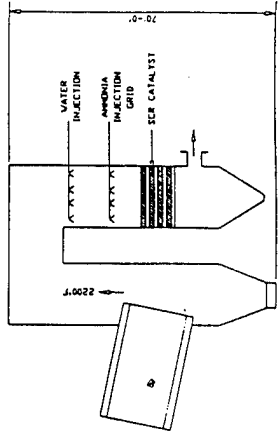

G. INCINERATOR GENERAL ARRANGEMENT
SCALE: NONE

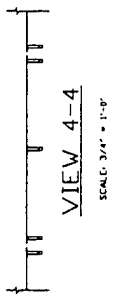

VIEW 4-4
SCALE: 3/4" = 1'-0"

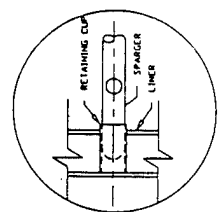

DETAIL 'X'

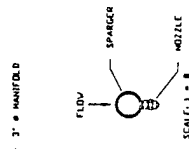

SCALE: 1" = 8"

Figure 35. Incinerator,
63
(The reverse of this page is blank)

1. Catalyst Block Design

The catalyst blocks are 2-feet by 2-feet by 4-inches deep and are made by placing 2-mm thick screens at 4-mm intervals in a channel-shaped frame.

2. Catalyst Panel Design

The catalyst panel comprises an array of catalyst blocks five across and six high. A T-shaped frame surrounds the blocks around the perimeter of the panel. Intermediate stiffeners add rigidity and aid in retaining the blocks in the panel. The blocks are not welded to each other or to structural members of the frame. Gaskets are provided between the frame and the block to prevent bypass of gas around the catalyst and to give allowance for possible differential thermal expansions. Rods are installed through the panel at the intersection of the retaining bars to provide a snug fit and to keep the bars close to the catalyst face.

3. Catalyst Housing

The catalyst housing is an internally insulated box with inlet and outlet flanges on the top and bottom, respectively. Inside the box are shelves that will support the catalyst panels.

4. Loading and Unloading

The catalyst is loaded by removing an access cover on the side of the unit, sliding the panels in horizontally, and replacing the access cover. The catalyst housing will be integral with the ductwork and will be designed to sustain loads from above.

5. Ammonia Injection Grid

The AIG is a series of spargers that branch from a manifold or header, which in turn connects to the ammonia supply line. The spargers will be subjected to high temperatures and therefore will be made of stainless steel. Each sparger will have a set of nozzles attached to it in a staggered pattern to evenly spray ammonia. The nozzles will be installed on the downstream side of each sparger to allow the spray pattern to develop better. Outside the ductwork, the spargers meet the manifold at flanged connections. If required, flow control valves can be installed on every branch to fine tune the ammonia flow.

E. CATALYST FABRICATION AND COST

The catalyst consists of mordenite (with copper mordenite for test cell use) attached to a screen by means of a high-temperature adhesive. The catalyst must be of sufficiently small mesh size to minimize internal diffusion at the extremely high reaction rates achieved, but not so small that it becomes completely immersed in the adhesive. Successful catalysts have been prepared from 50/100 mesh (9) to 20/30 mesh (7) by this procedure.

The catalyst is fabricated by coating a 4-inch wide strip of stainless steel mesh wire cloth (40 x 40 mesh) with a selected high-temperature adhesive. The ground catalyst is then dusted over the adhesive and pressed between rollers to a pressure of about 20 pounds per square inch. The catalyst-coated screen is then rolled up, with spacers to provide the desired gap spacing between the screen (3- to 4-mm). To form a 3-foot diameter roll, 363 linear feet of screen is used. After forming the coiled screen, the adhesive is heat treated to at least 200°C and usually 480°C to dry it. The resulting catalyst may then be used directly in the SCR application.

One such 4-inch-long coil of catalyst in a 3-foot diameter vent tube exhibits 121 ft² of surface area. To prepare a 24-inch deep catalyst zone requires six such coils, or 726 ft². To fill 56 vent tubes, 40,656 ft² of screen is needed. At a quoted price of \$1.70/ft², this screen cost is \$69,000. The screen for 56 vent tubes will contain approximately 2500 pounds of catalyst, at a cost of \$25,000. The total cost of the unit is thus estimated to be:

| | | |
|---------------------------------------|----|---------------|
| Catalyst/Screen Cost | \$ | 94,000 |
| Catalyst Container Fabrication (150%) | | 141,000 |
| Assembly/Field Fabrication | | <u>15,000</u> |
| TOTAL | \$ | 250,000 |

Although all catalysts to date have been manufactured using stainless steel screen, it is possible that less-expensive materials can be used since it need not have structural strength and since the screen is completely coated with high-temperature adhesive. A detailed review of the means to reduce the catalyst cost would be conducted in Phase II.

SECTION V

CONCLUSIONS AND RECOMMENDATIONS

A. CONCLUSIONS

From the Phase I program, the following conclusions are drawn:

1. The mordenite/copper mordenite catalyst system is well suited for Air Force applications to jet engine test cells or incinerators, in that
 - a. it exhibits extremely high activity, requiring small amounts of catalyst
 - b. it maintains this high activity at temperatures of at least 600°C, without promoting undesirable side reactions leading to decreased NO_x conversion
 - c. it can be configured to provide high activity over a wide range of temperatures, by proper balancing of the amounts of mordenite and copper mordenite catalysts, and
 - d. it utilizes ammonia very efficiently.
2. As a result of these characteristics, it is unnecessary to incur the cost, retrofit difficulties, and operational problems of heat transfer to reduce catalyst operating temperatures below 600°C, as conventional SCR systems require.
3. A minimum-impact retrofit appears possible, by inserting catalyst coils into existing vent tubes of the test cell muffler.
4. For smaller jet engines, the exhaust flow and temperature characteristics are such that a mordenite catalyst functions effectively in the vent tube reactor. For larger engines, a 50 percent mixture of mordenite over copper mordenite is effective in the vent tube reactor. The latter configuration will also function for smaller engines.
5. For high-temperature incinerators, the mordenite catalyst is suitable for NO_x control.
6. Conceptual process designs and instrumentation designs suggest that the dual-bed system can readily be adapted to Air Force applications in retrofit designs with minimal impact on operational considerations.

B. RECOMMENDATIONS

From the Phase I program, the following recommendations are made:

1. The mordenite--copper mordenite catalyst system appears highly suitable for engine test cell applications, and further demonstration of the concept should be undertaken.

2. The vent tube reactor is very easy to adapt to test cells, and scale-up and demonstration should be undertaken. The full-scale demonstration would consist of applying the catalyst shown to be effective in one tube, to the entire bank of 56 tubes. Laboratory studies should be undertaken at an appropriate scale to simulate one tube, demonstrating both catalyst fabrication and reactor operation. This program should lead to a low-cost field demonstration on one full sized tube in a field location.

3. The proper location of ammonia injectors should be established, to ensure that the high-temperature ejector tube or equipment does not catalyze undesired oxidation reactions of ammonia. If so, either the equipment must be painted with inert, high-temperature cement or the ammonia injection location moved downstream of the augmentor tube.

4. As with any parallel-passage reactor, the catalyst system should be capable of handling dust or unburned hydrocarbons. These characteristics of the exhaust gas must be fully evaluated, to ensure that a proper gap spacing has been selected.

REFERENCES

1. Kittrell, J.R., Willey, R.J., and Eldridge, J.W., "Mechanistic Model of the Selective Catalyst Reduction of Nitric Oxide with Ammonia," Ind. Eng. Chem. Prod. Res. Dev., **24**, 226 (1985).
2. Cichanowicz, J.E., "Selective Catalytic Reduction for Coal-Fired Power-Plants: Feasibility and Economics," EPRI CS-3603, RP 1256-7, October (1984).
3. Yamaguchi, M., Matsushita, K.M. and Takami, K., "Remove NO_x from HNO₃ Tail Gas," Hydrocarbon Processing, **55** (8), 101 (1976).
4. Kittrell, J.R. and Herman, D.H., "Process for Reducing Nitrogen Oxides," U.S. Patent 4,473,536, September 25 (1984).
5. Kittrell, J.R., Medros, F.G., and Eldridge, J.W., "Dual Catalyst System to Broaden the Window of Operability in the Reduction of NO_x with Ammonia," AIChE Meeting , New York, November 17 (1987).
6. Nam, I.S., "Experimental Study and Theoretical Modeling of NO_x Reactions," Ph.D. Thesis, Department of Chemical Engineering , University of Massachusetts, Amherst, 328pp. (1983).
7. Medros, F.G., "Experimental Investigation of a Dual-Catalyst for the Selective Catalytic Reduction of Nitric Oxide with Ammonia," M.S. Thesis, Department of Chemical Engineering, University of Massachusetts, Amherst, 368pp. (1987).
8. Kittrell, J.R., Darian, S.T., and Eldridge, J.W., "Catalysts for NO_x Reduction by Ammonia," Environmental Progress, **1** (2), 84 (1982).
9. Ganti, M.P., "Theoretical and Experimental Analysis of Parallel Plate Reactors," Ph.D. Thesis, Department of Chemical Engineering, University of Massachusetts, Amherst, 256pp. (1980).
10. Kittrell, J.R. and Eldridge, J.W., "Novel Catalyst Preparation Method for NO_x Control," Environmental Progress, **4** (2), 78 (1985).
11. "Process Removes NO_x from Exhaust Gases," Chem. Eng. News, p.6, December 22 (1986).

REFERENCES (CONCLUDED)

12. Spicer, C.W., Holdren, M.W., Miller, S.E., Smith, D.L., Smith, R.N., Kuhlman, M.R., and Hughes, D.P., Aircraft Emission Characterization: TF41-A2, TF30-P103, and TF30-P109 Engines, Report No. ESL-TR-87-027, Tyndall AFB, Florida, and Battelle, Columbus, Ohio, December (1987).
13. Spicer, C.W., Holdren, M.W., Miller, S.E., Smith, D.L., Smith, R.N., and Hughes, D.P., Aircraft Emissions Characterization, Report No. ESL-TR-87-63, Tyndall AFB, Florida, and Battelle, Columbus, Ohio, March (1988).