

AGARD

ADVISORY GROUP FOR AEROSPACE RESEARCH & DEVELOPMENT
7 RUE ANCELLE 92200 NEUILLY SUR SEINE FRANCE

AGARD ADVISORY REPORT 328

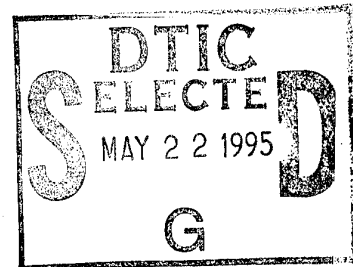

Structures and Materials Panel Working Group 26 on High Temperature Cyclic Behaviour of Aerospace Materials: Room Temperature Validation Tests of Ti-6Al-4V

(Le Comportement Cyclique Haute Température
des Matériaux Aérospatiaux:

Les Essais de Validation du Ti-6Al-4V
à Température Ambiante)

*This Advisory Report was prepared at the request of the
Structures and Materials Panel of AGARD.*

19950518 071

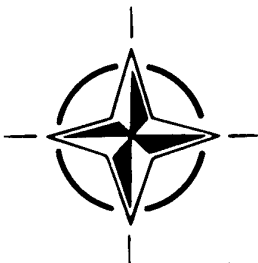

NORTH ATLANTIC TREATY ORGANIZATION

DISTRIBUTION STATEMENT A
Approved for public release;
Distribution Unlimited

AGARD

ADVISORY GROUP FOR AEROSPACE RESEARCH & DEVELOPMENT

7 RUE ANCELLE 92200 NEUILLY SUR SEINE FRANCE

AGARD ADVISORY REPORT 328

**Structures and Materials Panel
Working Group 26 on**

**High Temperature Cyclic Behaviour
of Aerospace Materials:**

**Room Temperature Validation Tests
of Ti-6Al-4V**

(Le Comportement Cyclique Haute Température
des Matériaux Aérospatiaux:

Les Essais de Validation du Ti-6Al-4V
à Température Ambiante)

Interim Report by

C. Wilkinson and C.R. Gostelow
Defence Research Agency
Materials and Structures Department
RAE Pyestock
Farnborough, Hants, U.K.

This Advisory Report was prepared at the request of the
Structures and Materials Panel of AGARD.

Accession For	
NTIS CRA&I	<input checked="" type="checkbox"/>
DTIC TAB	<input type="checkbox"/>
Unannounced	<input type="checkbox"/>
Justification	
By	
Distribution /	
Availability Codes	
Dist	Avail and/or Special
A-1	

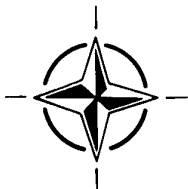

North Atlantic Treaty Organization
Organisation du Traité de l'Atlantique Nord

The Mission of AGARD

According to its Charter, the mission of AGARD is to bring together the leading personalities of the NATO nations in the fields of science and technology relating to aerospace for the following purposes:

- Recommending effective ways for the member nations to use their research and development capabilities for the common benefit of the NATO community;
- Providing scientific and technical advice and assistance to the Military Committee in the field of aerospace research and development (with particular regard to its military application);
- Continuously stimulating advances in the aerospace sciences relevant to strengthening the common defence posture;
- Improving the co-operation among member nations in aerospace research and development;
- Exchange of scientific and technical information;
- Providing assistance to member nations for the purpose of increasing their scientific and technical potential;
- Rendering scientific and technical assistance, as requested, to other NATO bodies and to member nations in connection with research and development problems in the aerospace field.

The highest authority within AGARD is the National Delegates Board consisting of officially appointed senior representatives from each member nation. The mission of AGARD is carried out through the Panels which are composed of experts appointed by the National Delegates, the Consultant and Exchange Programme and the Aerospace Applications Studies Programme. The results of AGARD work are reported to the member nations and the NATO Authorities through the AGARD series of publications of which this is one.

Participation in AGARD activities is by invitation only and is normally limited to citizens of the NATO nations.

Published June 1994

Copyright © AGARD 1994
All Rights Reserved

ISBN 92-835-0716-9



*Set and printed by Specialised Printing Services Limited
40 Chigwell Lane, Loughton, Essex IG10 3TZ*

Preface

This report contains all relevant information on the validation exercise conducted by participants of AGARD SMP WG26. Materials specification and distribution of Ti-6Al-4V specimens are presented along with the collated data from those participants that have supplied test results. Crack propagation and strain control low cycle fatigue data are discussed, along with a number of points of clarification regarding test technique.

Préface

Ce rapport contient toutes les informations utiles issues de la campagne de validation effectuée par les participants au WG 26 du Panel AGARD SMP. La spécification des matériaux ainsi que la distribution des échantillons Ti-6Al-4V sont présentées, avec les données recueillies auprès des participants qui ont fourni des résultats d'essais.

Les données obtenues pour la propagation des fissures et la fatigue oligocyclique lors des essais à déformation imposée sont discutées, ainsi qu'un certain nombre de points de clarification concernant les techniques d'essais.

Participating Laboratories

Participant	Contact	Code
Portuguese Air Force (Portugal)	Cpt. J.P.R.C. Pires	PAF
Middle East Technical University (Turkey)	Prof. M. Doruk	METU
University of Pisa (Italy)	Dr R. Galatolo	PISA
Fiat Avio (Italy)	Dr E. Campo	FIAT
CNR-ITM (Italy)	Dr M. Marchionni	ITM
IABG (Germany)	Dr P. Heuler	IABG
CEAT (France)	Dr E. Jany	CEAT
Ruston Gas Turbine (UK)	Dr D. Allen	GEC
Hellenic Air Force (Greece)	Mr L. Kompotiatis	KETA
SNECMA (France)	Mr J.C. Lautridou	SNEC
Defence Research Agency (UK)	Mr C. Gostelow	RAE
Naval Air Development Centre (US)	Dr C.E. Neu	NADC
IAR/NAE — originally NCR/NAE (Canada)	Dr P. Au	NAE

Contents

	Page
Preface/Préface	iii
Participating Laboratories	iii
1. Introduction	1
2. Objectives	1
3. Methods and Means of Accomplishment	1
4. Materials and Specimens	1
4.1 Material	1
4.2 Cut-up	1
4.3 Specimen Design	1
4.3.1 Compact Tension (CT)	3
4.3.2 Low Cycle Fatigue (LCF)	3
5. Test Procedures and Programmes	3
5.1 Test Procedures	3
5.2 Programme Status	3
5.3 Test Matrix	4
6. Results	
6.1 Compact Tension	4
6.1.1 Previous TX114.(SC33) Data	4
6.1.2 Data by WG26 Laboratories	4
6.2 Low Cycle Fatigue (LCF)	4
6.2.1 Basic Data	4
6.2.2 Data by WG26 Laboratories	4
6.2.3 Inter-lab Comparison	4
6.3 Dynamic Stress Strain Curve	4
7. Discussion	4
8. Conclusions	5
9. References	5
Appendices	
1. Notes for guidance: Handling Titanium LCF Specimens	17
2. Guidelines for AGARD-SMP WG26 Crack Growth (CT) Testing	17
3. Guidelines for AGARD-SMP WG26 Strain Controlled LCF Testing	18
4. Tabulated Strain Control LCF Data by Laboratory	21

1. INTRODUCTION

The cost of validating new materials and design methods is placing increased emphasis on laboratory data for component life and safety. In the aero gas turbine the use of higher strength materials has led to the introduction of damage tolerant concepts, and the need for elevated temperature crack growth data encompassing both complex loading and short crack behaviour. Similarly the introduction of materials with higher temperature capability has placed greater emphasis on the role of creep and on studies of strain control fatigue behaviour.

Within the family of AGARD nations, all are either manufacturers of or customers for advanced military engines. They thus have a common need for accepted international standards for materials testing, data analysis and data presentation, particularly as they relate to design, life and safety.

The member nations have a widespread collective involvement with Materials Testing, and have already gone a long way towards establishing standards for room temperature testing through AGARD-SMP TX114, latterly SC33. The parallel test programme described here, directed towards High Temperature Cyclic Behaviour, was a logical extension of that activity.

All laboratories involved with the activity have benefited from the exchange of information and experience that has occurred. Non participating laboratories will benefit from the testing standards that have emerged, allowing for meaningful data exchange to take place both within and between countries.

2. OBJECTIVES

The overall objective of the full programme, of which the testing of Ti-6Al-4V covered in this report forms part, is to establish internationally accepted and agreed methods for elevated temperature testing, data collection and data analysis for aerospace materials, particularly with regard to crack growth and low cycle fatigue.

Although the programme was initially designed for engine disc materials, the methods will be applicable to other high temperature materials and components. In particular the programme will have relevance to the high temperature airframe components which are seen as important for the next generation of high speed aircraft.

3. METHODS AND MEANS OF ACCOMPLISHMENT

The programme has been arranged in two phases, a room temperature *validation* programme using Ti-6Al-4V and a *core* programme on the nickel based alloy IN718 at 600°C.

The validation programme had a two fold objective: Firstly to validate laboratories who had not taken part in the previous TX114 exercise for room temperature crack growth testing. Secondly to test laboratories' capability of strain controlled fatigue testing at room temperature, to make it possible to separate out problems of testpiece design, gripping and extensometry from problems associated with furnaces and temperature control. In this respect Ti-6Al-4V is an ideal material as it has similar cyclic strain softening behaviour to IN718, and is well understood and documented.

To avoid the expense of laboratories with pre-existing strain control fatigue and elevated temperature testing capability having to re-equip, it was agreed that such laboratories would use their existing methods for the validation programme. For

such laboratories the initial room temperature LCF programme acted as an interlab comparison and, in the context of the overall programme, helped in the development of the test guidelines.

Laboratories without previous experience were given information on specimen design and extensometry from experienced participants and, in the case of Southern Flank Nations, offered support from the UK by way of visits to the RAE for their staff and the return visit of an RAE scientist to their laboratory. In the actual programme it was suggested that all laboratories needing to purchase equipment should consider standardising on the Rolls-Royce LCF specimen design and MTS side entry extensometers, the latter being the most common in use in the experienced laboratories.

Test guidelines were drawn up before actual testing began, based on existing documentation: in the case of crack growth, AGARD-R-766⁽¹⁾ and for the LCF the HTMT committee's code of practice for constant amplitude LCF testing at elevated temperatures⁽²⁾ which is similar to the VAMMAS methodology, modified and simplified in the light of experience of aerospace materials.

The actual test programme was small, emphasis on the initial programme being targeted on methodology rather than on creating databases. This enabled a realistic time limit of three years to be placed on the validation and core programmes.

4. MATERIALS AND SPECIMENS

4.1 Material

The Ti-6Al-4V was supplied by Rolls-Royce, Derby in the form of a segment from a heat treated 'black forging' of an RB211 fan disc similar to that used for the TX114 (SC33) 'Cold Disc Testing Programme' and reported in AGARD-R-766⁽¹⁾. The material (see Figure 1) has an alpha grain size of 13µm, beta grain size of 18µm and an alpha packet size of 14µm. Figure 2 shows the forging cut into three segments suitable for production of blanks.

The disc was heat treated prior to sectioning and delivery to RAE. The disc had been part of a validation exercise and as such should be considered as production standard material.

The heat treatment was:

Homogenising	945°C — 970°C	1Hr	Water Quench
Ageing	700°C	2Hr	Air Cool

4.2 Cut Up

The disc was sectioned in accordance with the cut up diagram reproduced as Figure 3. Once sectioned two courses of action were followed dependent on laboratory.

- (1) LCF blanks were supplied direct to participants for manufacture of specimens; these included blanks designated ITM, NAE, CEAT, IABG and SNECMA.
- (2) Specimens were supplied in a machined state, all designated RR (LCF) and CP (Compact Tension) being machined centrally by companies approved by Rolls-Royce to manufacture such specimens.

Distribution of blanks and/or specimens was in accordance with written requests from participants to the co-ordinator.

4.3 Specimen Design

In order to ensure that laboratories could use existing equipment, particularly furnaces, draw bars and extensometers, some variation in specimen design was permitted.

Included in this document are the various specimen geometries used by the participants.



Fig. 1 Transverse section through specimen RAE1 923 cycles X 800 Etched — Kroll's reagent

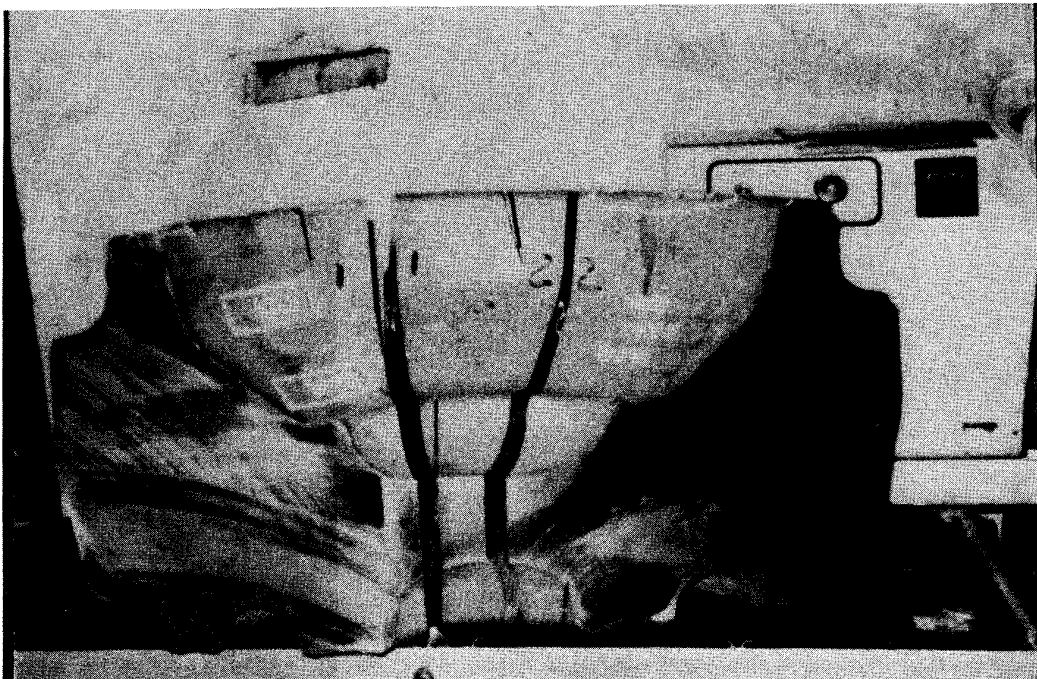

Fig. 2 Ti-6Al-4V "black forging" prior to production of specimens and blanks

4.3.1 Compact Tension (CT)

Drawings of the two compact tension designs used are shown in Figure 4(a), SNECMA, and Figure 4(b), other laboratories (CP).

4.3.2 Low Cycle Fatigue (LCF)

Drawings of the Low Cycle Fatigue specimens used are reproduced in Figure 6: 6(a) ITM, 6(b) NAE, 6(c) FIAT, 6(d) IABG, 6(e) RR and 6(f) RAE.

5. TEST PROCEDURES AND PROGRAMMES

5.1 Test Procedures

Prior to the commencement of the programme all potential participants were requested to forward details of their laboratory capabilities and methods for crack growth and low cycle fatigue testing. Following analysis of the returns, initial test guidelines were agreed. These have been amended in the light of experience gained.

Final test procedures for both crack propagation (CT) and LCF testing are included as Appendices 2 and 3. No major

problems have been encountered; however the following points should be noted.

Some difficulties have been experienced by laboratories when attempting to produce the trapezoidal waveform specified in the guidelines, and it has been agreed that they may use a triangular waveform of the same frequency. Additional tests have been conducted at RAE to cross-correlate between the two waveform types. It is anticipated that whilst not having an effect at room temperature, this could be of greater significance for the IN718 testing at 600°C.

With regards to the crack propagation testing, it should be stressed that the data have been collected from stress intensity ranges of the order of 15MPa/m. This was deemed necessary if the data base generated was to be of use in computer based lifing models.

5.2 Programme Status

To date, 70 specimens from the Ti-6Al-4V disc have been ordered and delivered. The status of the actual testing programme is detailed in Table 1, with shaded boxes denoting results supplied or specimens scrapped.

Table 1
Supply of Ti-6Al-4V specimens and blanks

No	Blank type designation							
	RR	CP	ITM	RAE	NAE	CEAT	IABG	SNEC
1		GEC	ITM	RAE	PAF		IABG	SNEC
2	NADC	GEC	ITM	RAE	PAF		IABG	SNEC
3	NADC	GEC	ITM	RAE	PAF		IABG	SNEC
4	NADC	NAE	FIAT	RAE	FIAT			
5		NAE	FIAT	RAE	FIAT			
6	KETA	XXX	FIAT	RAE	NAE			
7	KETA	NAE	FIAT	RAE	NAE			
8	RAE	XXX		RAE	NAE			
9		XXX		RAE				
10	PISA	XXX		RAE				
11	PISA	KETA		RAE				
12	PISA	KETA		RAE				
13	KETA	KETA						
14	KETA	ITM						
15	KETA	RGT						
16		RGT						
17		RGT						
18		METU						
19		METU						
20		METU						
21		ITM						
22		ITM						
23		PAF						
24		PAF						
25		PAF						

5.3 Test Matrix

The test matrix for the validation programme consisted of

CT Specimens

Specimen 1 to 3 — Stress intensity range 10-50 MPa \sqrt{m}

LCF Specimens

Specimen 1 Total strain range = 0.020mm/mm (2%)

Specimen 2 Total strain range = 0.010mm/mm (1%)

Specimen 3 Total strain range = 0.013mm/mm (1.3%)

6. RESULTS

All results received by the start of September 1991 have been included. Initial tests consisted of two room temperature tensile tests as a quality control check. These results have been reproduced as Table 2 below.

Table 2
Tensile properties of Ti-6Al-4V

Tensile Test No:	T1	T2
Gauge Length mm	28.00	28.00
Diameter mm	5.64	5.63
Area mm ²	24.98	24.98
Yield Load KN	22.87	23.39
Yield Stress MPa	916	940
Max. Load KN	24.83	24.87
Max. Stress MPa	994	999
Elongation %	11	11
R of A %	39	37

6.1 Compact Tension

Laboratories who were not participants in AGARD SMP TX114 (SC33) initially supplied crack growth (CT) data in various forms. Some supplied graphs, some 'a' vs 'N' data whilst others supplied da/dN vs ΔK data. This led to problems in data analysis and presentation, particularly for the inclusion of crack growth data in PC databases. Ideally the data should be supplied as 50 sets of data pairs for crack length and cycles, and laboratories were requested to re-submit data in this form.

The crack front is not uniform across the width of the specimen, as illustrated in Figure 5. The final crack length was measured by either (a) taking the average of five readings across the specimen, or (b) measuring crack area and dividing by specimen width.

6.1.1 Previous TX114 (SC33) Data

Published data of TX114⁽¹⁾ show that RAE data from the earlier programme fell well within the scatter bands and can therefore be used as a reference for this exercise. These data are plotted in Figure 7.

6.1.2 Data by WG26 Laboratories

Data received to date include three tests from NAE/NRC

(Figure 8), one test from KETA (Figure 9), three tests from GEC Whetstone (Figure 10), three tests from SNECMA (Figure 11), three tests from METU (Figure 12), and one from PAF (Figure 13). For comparison purposes all CT data are reproduced in Figure 14.

6.2 Low Cycle Fatigue (LCF)

All participating laboratories were requested to conduct fully reversed strain controlled low cycle fatigue tests at room temperature on the Ti-6Al-4V material in order to check the stability of the extensometry used.

6.2.1 Basic Data

Data obtained at RAE prior to the programme commencing are included for completeness.

6.2.2 Data by WG26 Laboratories

To date, results from six laboratories have been received totalling 18 individual tests; three from NADC, two from PISA, one from KETA, three from CNR/ITM, three from IABG, nine from RAE and three from NAE/NRC. The results are tabulated by laboratory in Appendix 4.

Fractography showed that specimens with lives of over 10,000 cycles showed intergranular cracking (Figure 15a). Specimens cycled between higher strain limits, and having shorter lives, exhibited mixed mode cracking (Figure 15b). Striated crack growth can be clearly seen in all specimens (Figure 16).

6.2.3 Inter-Lab Comparisons

The strain controlled LCF results from all laboratories are plotted in Figure 17. Figure 17a shows total strain range plotted against cycles to failure whilst Figure 17b plots elastic strain range against cycles. From these it can be seen that over most of the range there is surprisingly good agreement between laboratories.

6.3 Dynamic Stress-Strain Curve

For completeness a dynamic stress strain curve is plotted in Figure 18. This was obtained by incrementally increasing the strain range in a single specimen and noting the load range of the stabilised loop at each increment.

7. DISCUSSION

The results of the compact tension crack growth testing demonstrate that the AGARD-R-766 test procedures are robust and easily followed by both experienced and inexperienced laboratories. The additional support given in this programme concerning specification and availability of suitable test equipment was of added benefit. Indeed in the case of pulsed DC equipment at least one supplier was advertising compatibility with AGARD standards! It is believed that the extension of testing to IN718 at 600°C will be relatively straightforward.

One problem encountered was the variation in methodology used by laboratories to reduce the data set to 50 pairs and 'a' and 'N' values, and the tendency of laboratories with computer data collection systems to forward much more data than was required or could be reasonably handled in the PC databases. The data requirements in terms of modelling and databases perhaps need to be further explored and specified. This is also true of LCF data.

The LCF programme again demonstrated the robustness of the guidelines issued, the majority of the data falling in a quite

narrow scatterband. In comparing data it should be noted that scatter of an order of magnitude is often seen within a single laboratory for load controlled testing. By introducing the requirement for both static and dynamic moduli to be measured, and the requirement to produce a $\frac{1}{4}$ cycle and $\frac{1}{2}$ life hysteresis loop, most anomalous results were easily identified and explained.

For the future, a problem remains about the amount of data required to validate a test result, and the necessity of reducing the data included in design databases to a handleable amount. This might again benefit from further discussion at the conclusion of the full core programme and perhaps be the subject of further AGARD SMP activity.

8. CONCLUSIONS

The majority of the room temperature validation test programme on Ti-6Al-4V has been completed and included in this report. The results show that the test guidelines are ade-

quate, that the laboratories participating in the AGARD-SMP WG26 activity produce comparable data, and that the core test programme can be completed and analysed within the programme timescales.

Perhaps the most interesting observation on the benefits of the test programmes to date, both TX114 and WG26, is that the AGARD test guidelines are becoming used as "standard procedures" within many laboratories and in a number of other international collaborative programmes under the auspices of various agencies.

9. REFERENCES

- (1) AGARD Engine Disc Cooperative Test Programme AGARD-R-766, A J A Mom, M D Raizenne, Aug 1988.
- (2) A code of practice for Constant-Amplitude Low Cycle Fatigue Testing at elevated temp. — UK High Temperature Mechanical Testing Committee, 1986.

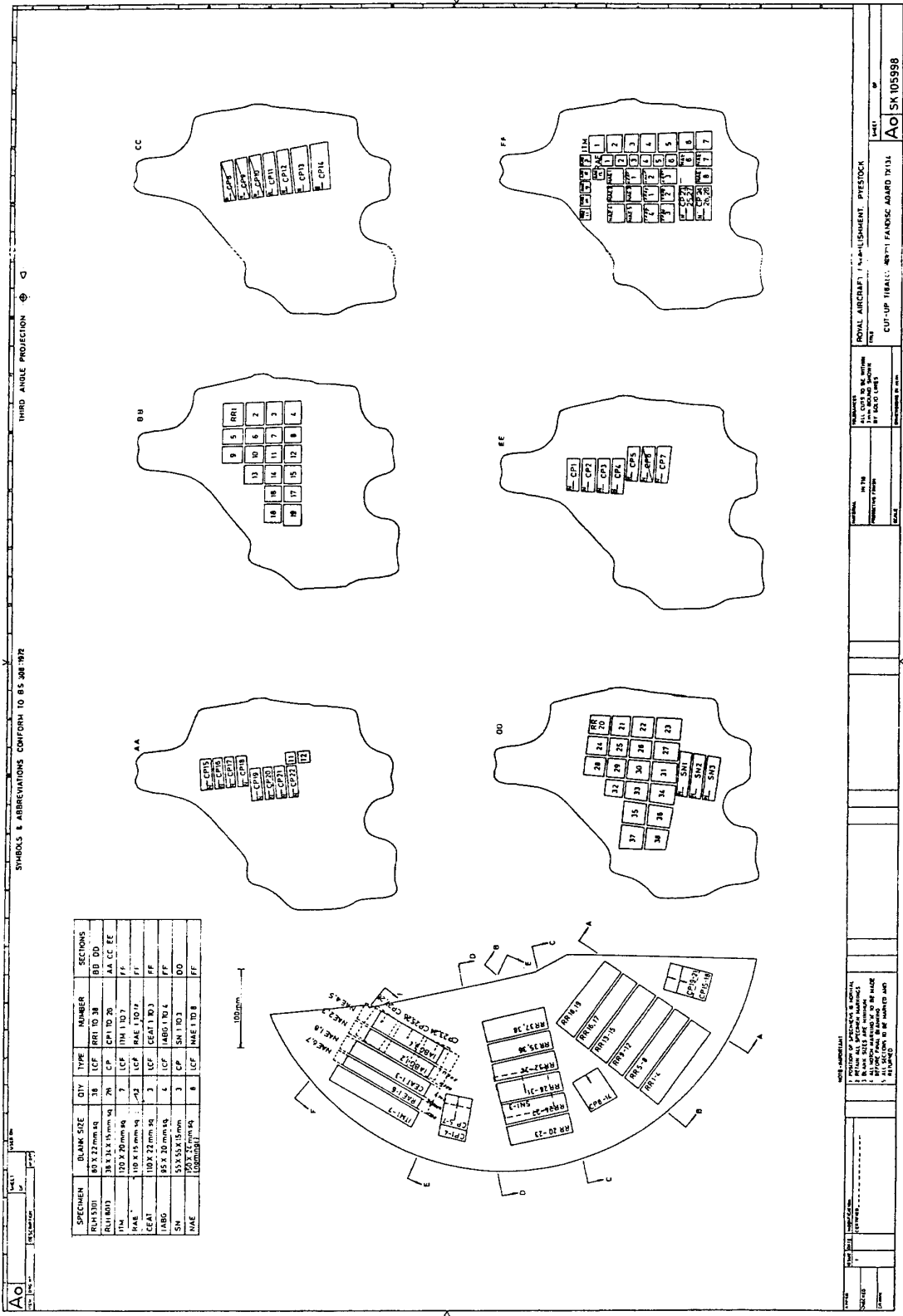
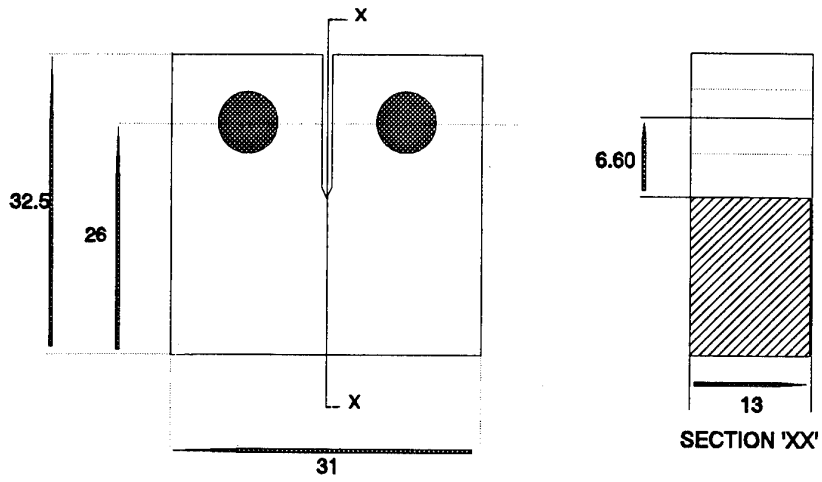

Fig. 3 Cut-up drawing of Ti-6Al-4V RB211 fan disc forging

a)



b)

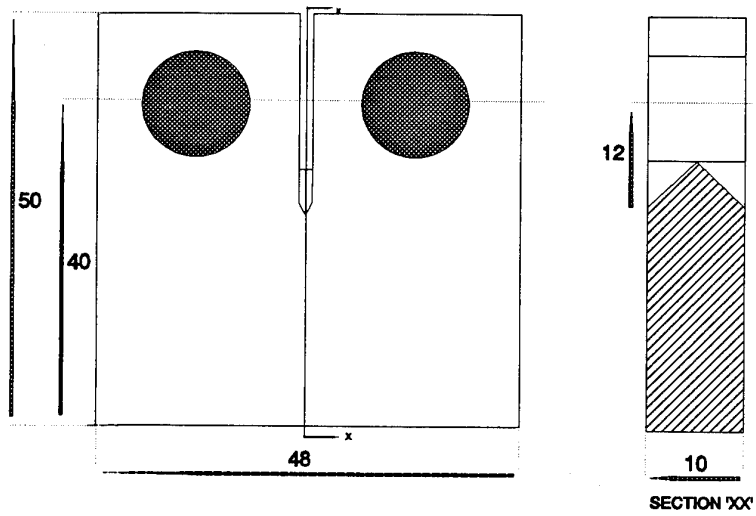

Fig. 4 Design of CT specimens a) CP b) SNEC

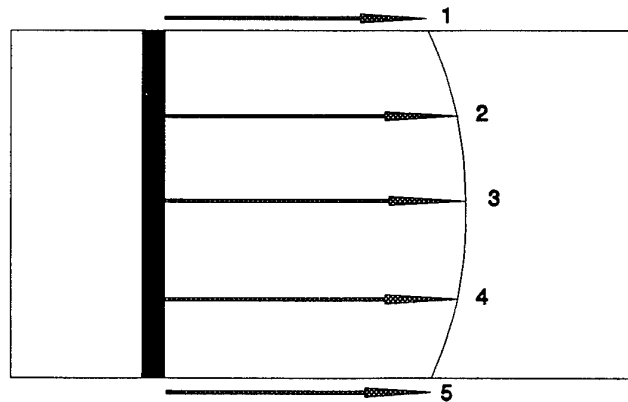

Fig. 5 Schematic of crack length measurement

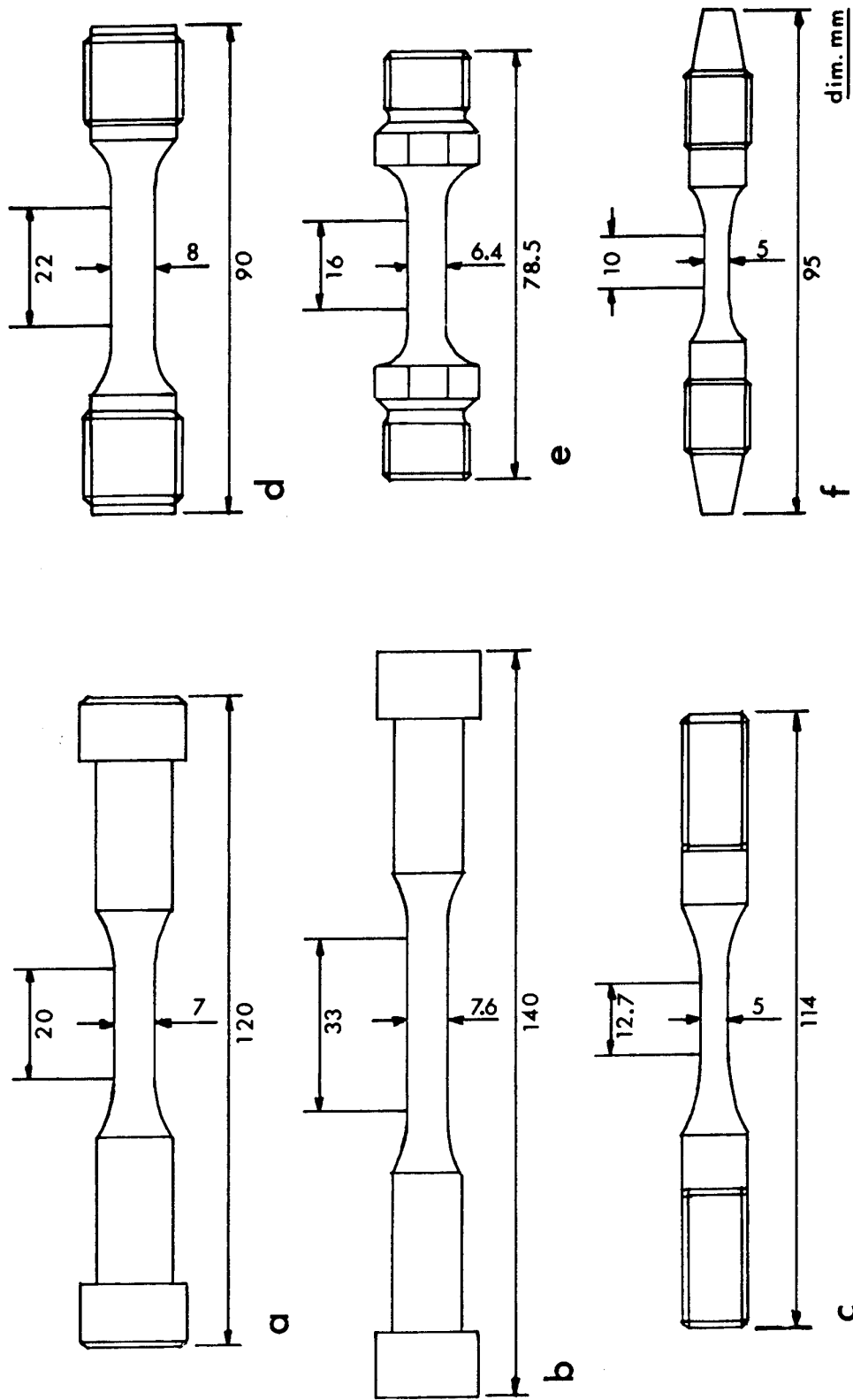

Fig. 6 Design of LCF specimens used in AGARD-SMP WG26 (a) ITM (b) NAE (c) FIAT (d) IABG (e) RR (f) RAE

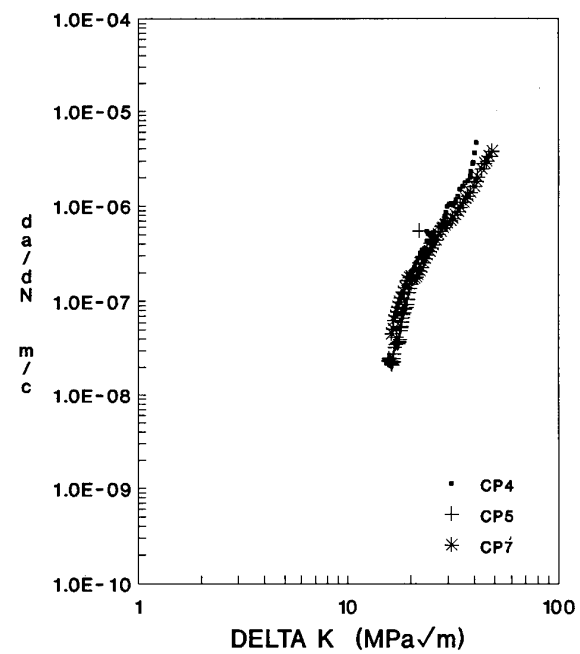
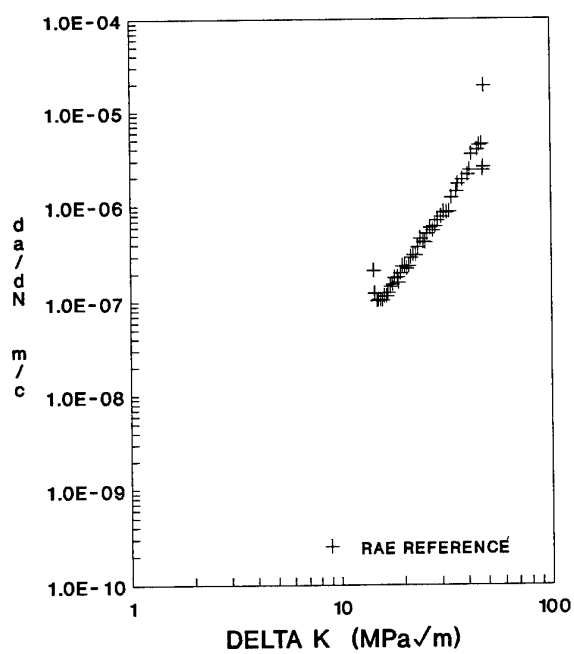
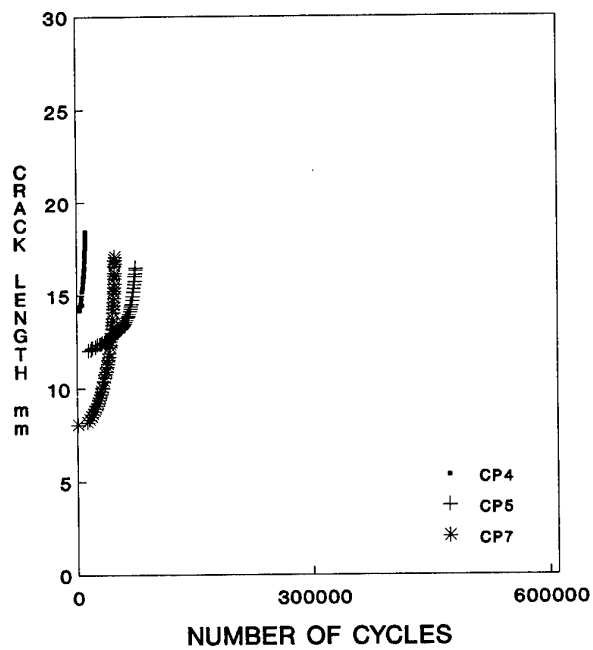
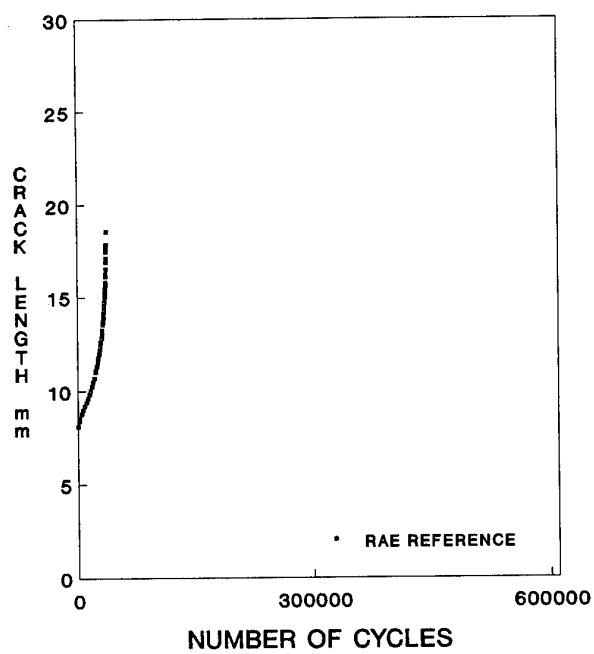

Fig. 7 RAE crack growth data, (a) a v N , (b) da/dN v ΔK

Fig. 8 NAE crack growth data, (a) a v N , (b) da/dN v ΔK

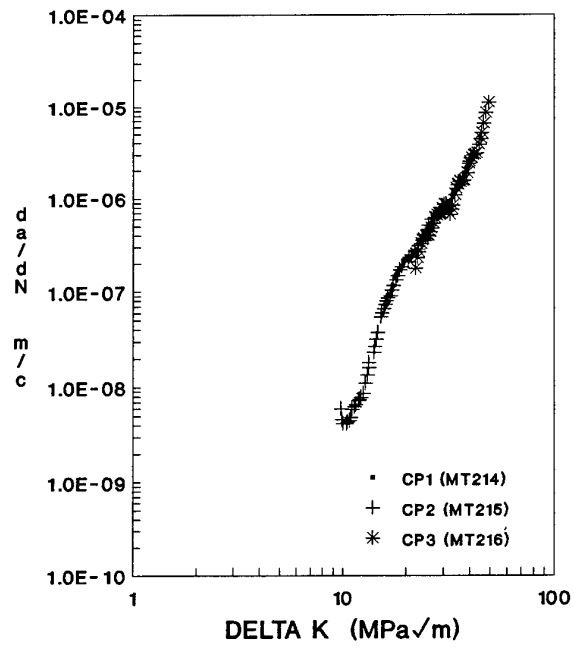
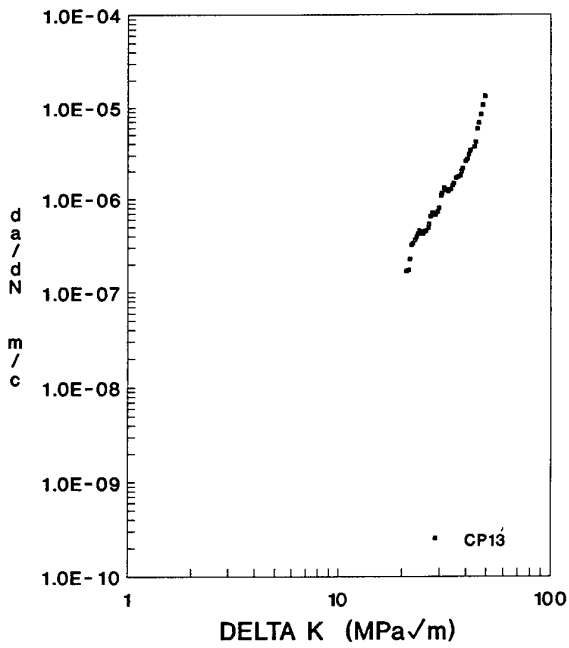
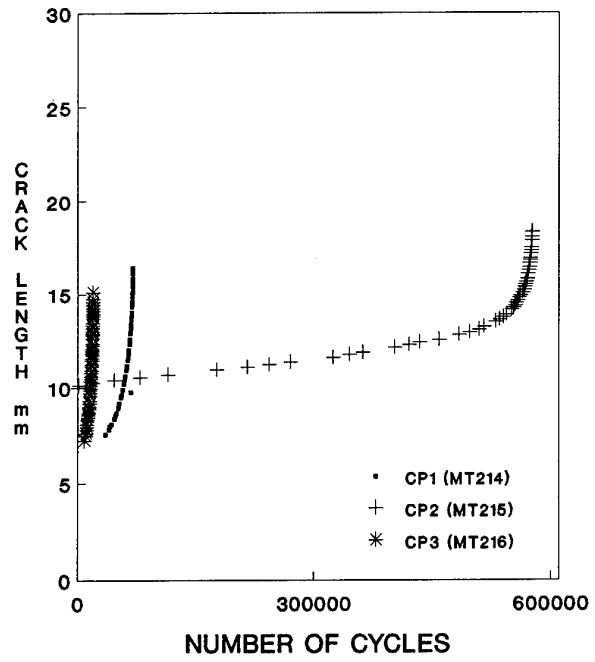
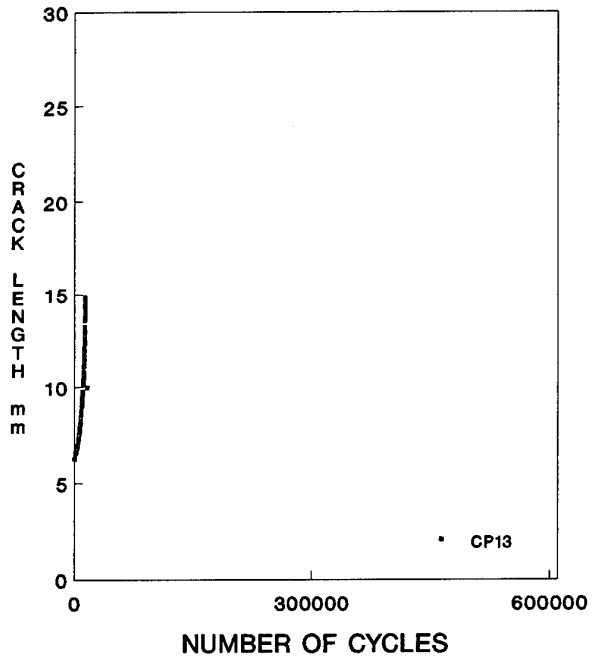

Fig. 9 KETA crack growth data, (a) $a \text{ v } N$, (b) $da/dN \text{ v } \Delta K$

Fig. 10 GEC crack growth data, (a) $a \text{ v } N$, (b) $da/dN \text{ v } \Delta K$

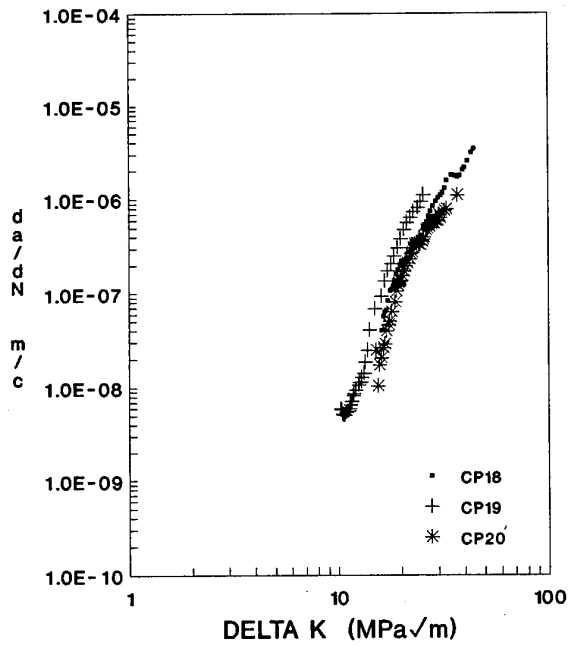
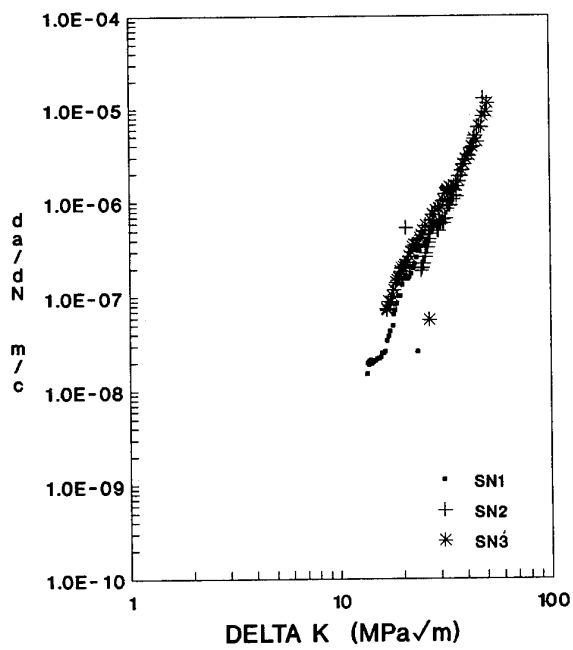
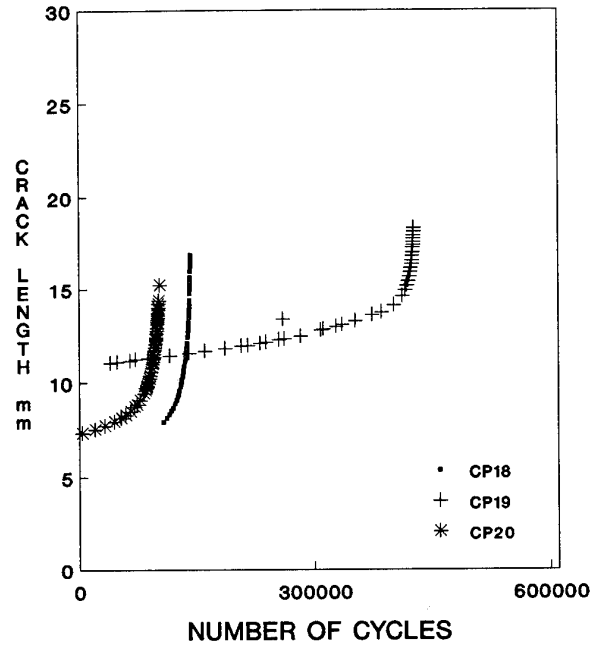
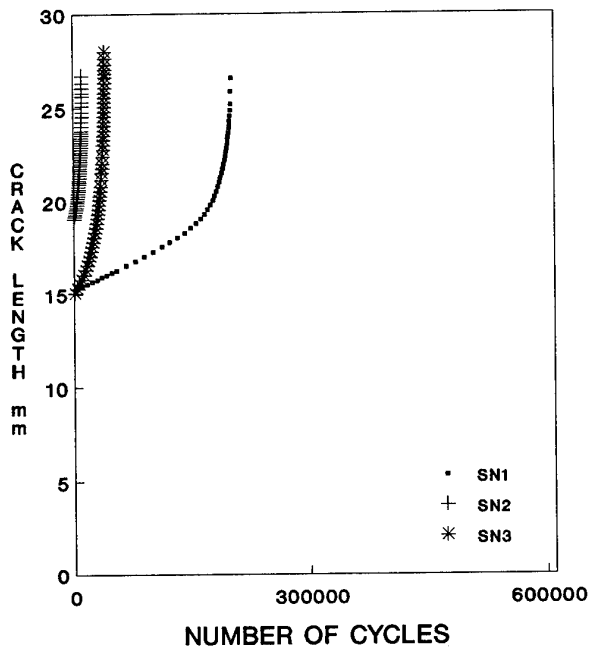

Fig. 11 SNECMA crack growth data, (a) a v N , (b) da/dN v ΔK

Fig. 12 METU crack growth data, (a) a v N , (b) da/dN v ΔK

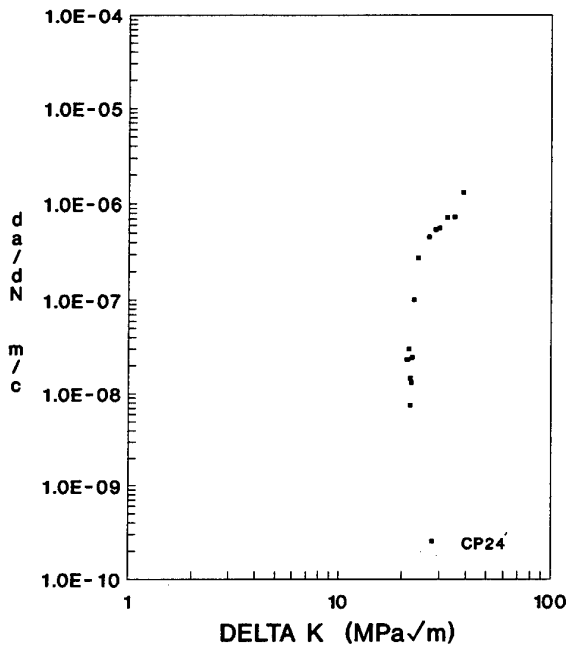
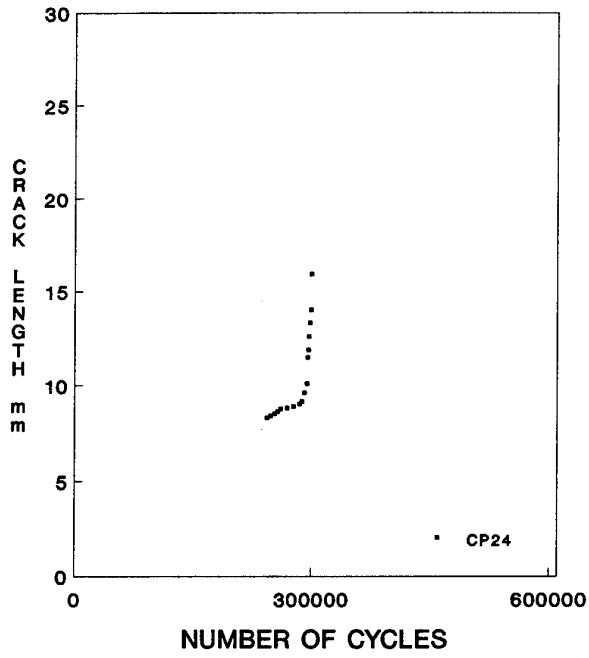

Fig. 13 PAF crack growth data, (a) a v N , (b) da/dN v ΔK

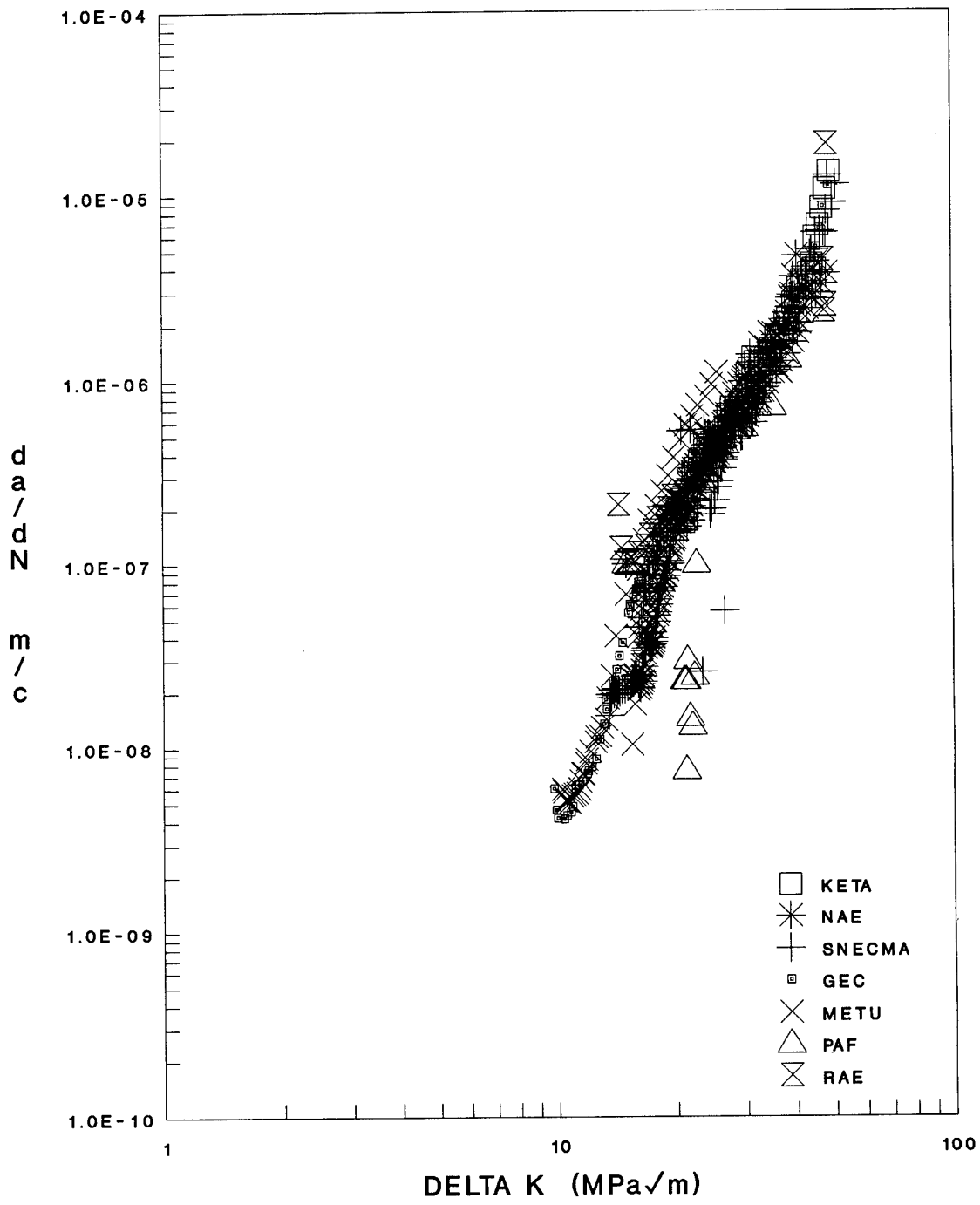

Fig. 14 Combined crack growth data, da/dN v ΔK



15a LCF RAE5 5345 cycles



15b LCF RAE6 10376 cycles

Fig. 15 Fractography of low cycle fatigue specimens

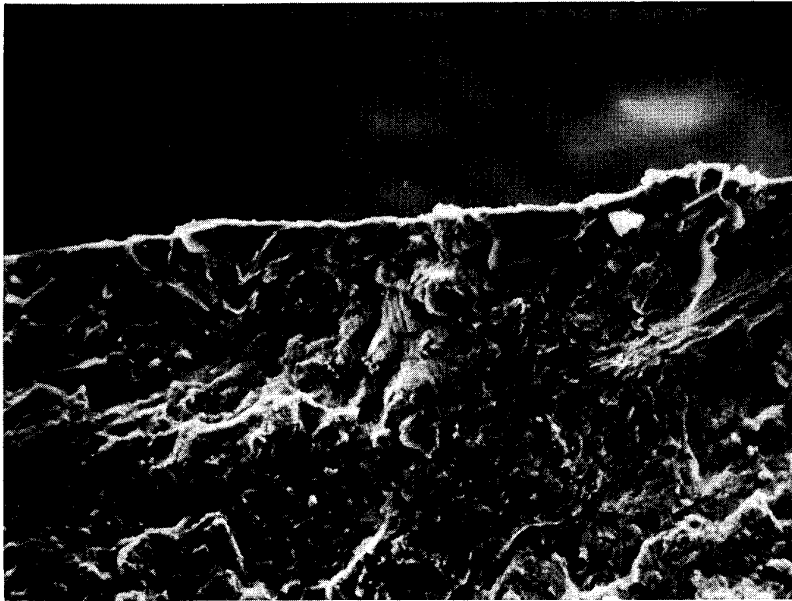

16a LCF RAE5 5345 cycles



16b LCF RAE5 5345 cycles

Fig. 16 Striated crack growth close to initiation site

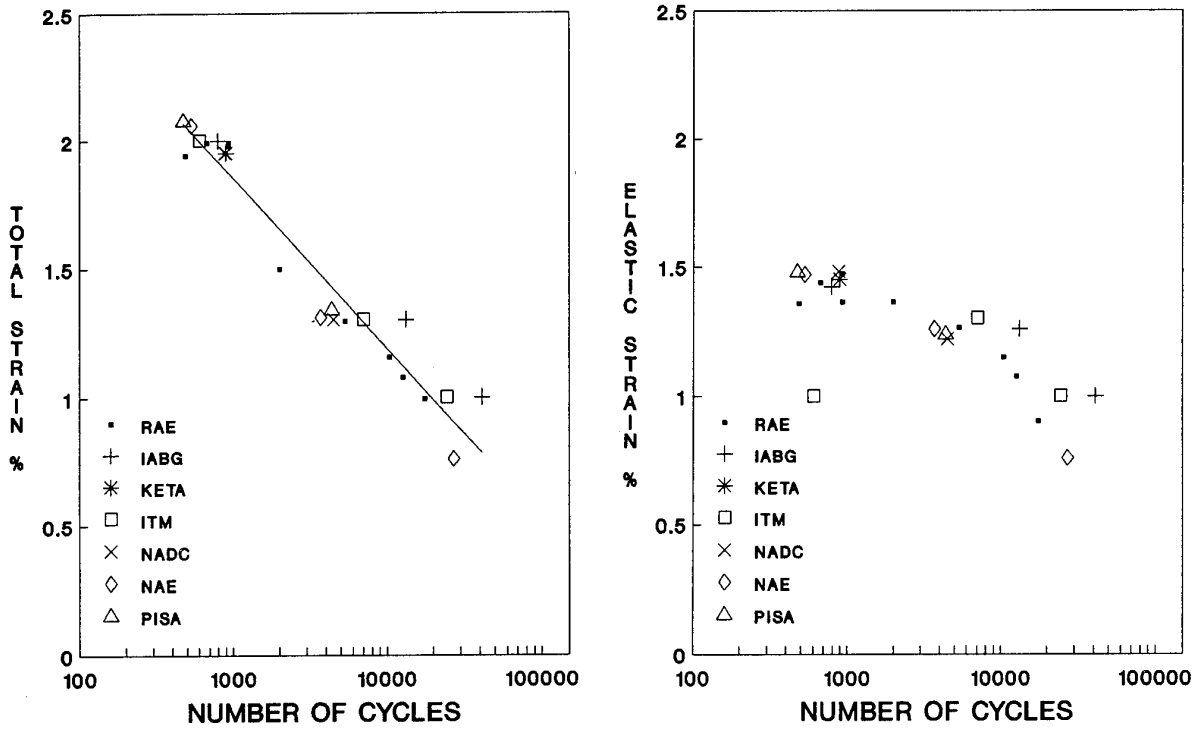

Fig. 17 Combined LCF data, (a) total strain v No. of cycles (b) elastic strain v No. of cycles

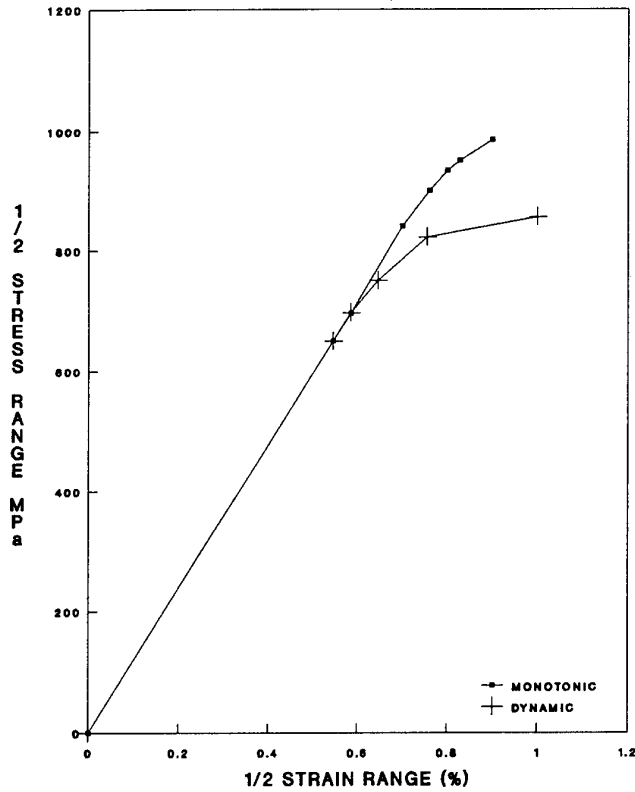

Fig. 18 Dynamic stress-strain Ti-6Al-4V 21°C

Appendices

1. Notes for guidance: Handling titanium LCF specimens
2. Guidelines for AGARD WG26 crack growth (CT) testing
3. Guidelines for AGARD WG26 strain controlled LCF testing
4. Tabulated Ti-6Al-4V strain controlled LCF data by laboratory

APPENDIX 1

NOTES FOR GUIDANCE: HANDLING TITANIUM LCF SPECIMENS

SPECIAL PRECAUTIONS:

To avoid problems of contamination care must be taken when handling titanium alloy specimens.

It is strongly recommended that the gauge length be cleaned with alcohol after installation in the testing machine.

Although not mandatory in WG26, where tests are on Ti-6Al-4V at room temperature, this is particularly important at elevated temperatures (in excess of 500°C) where fingermarks can cause premature crack initiation due to hot salt stress corrosion in small laboratory specimens.

APPENDIX 2

GUIDELINES FOR AGARD-SMP WG26 CRACK GROWTH (CT) TESTING

Introduction

These guidelines have been prepared to ensure consistency of testing and reporting in the elevated temperature crack propagation testing programme carried out under AGARD-SMP WG26 using compact tension (CT) specimens.

The test methods will follow closely those developed under AGARD TX114 for room temperature testing, modified and expanded where necessary for elevated temperatures. Details of the TX114 procedures can be found in AGARD-R-766 Appendix A, pages 54-73. Where no alternative is given, the details specified in AGARD-R-766 Appendix A will apply.

The test programme is divided into two components. Room temperature validation testing, mandatory only for those laboratories not participants in TX114, and the core testing programme on IN718.

Part 1 – Room Temperature Validation Programme

1.1 Material

Ti-6Al-4V disc material identical to that used in TX114.

1.2 Test methods

As AGARD-R-766 Appendix A, Section 3.3.

1.3 Reporting

As AGARD-R-766 Appendix A, Section 4.

Part 2 – Core Test Programme

2.1 Alloy and Test Temperature

IN718 supplied as pancake forgings by SNECMA and tested at 600°C.

Material will be supplied as finished testpieces to dimensions given in AGARD-R-766 Appendix A, Figure A1c.

An additional block of material approx. 30×20×10mm will be supplied for use as a reference block (dummy specimen).

2.2 Test method

The test method must follow exactly that defined in AGARD-R-766 Appendix A, Section 3.3, including the use of a reference block or dummy specimen. The reference block must be of a similar material to the actual test specimen and mounted adjacent to it in the furnace.

The temperatures of the specimen and reference blocks must be maintained within 5°C of each other.

2.3 Temperature measurement

For radiant heating (furnaces) the temperature should be measured by Pt/Pt-13%Rh thermocouples spot welded to the back face of the CT specimen and to the reference block. The actual temperature of the specimen and reference must be monitored and recorded throughout the test.

Test temperature data must also be recorded each time PD data are logged.

2.4 Heating schedule

The test should be commenced not less than one hour and not more than 24 hours after the specimen has reached the test temperature.

2.5 Insulation of wires

Thermocouple wires and current leads should be insulated using glass fibre sleeving or ceramic sheaths.

2.6 Test conditions and PD measurement

As AGARD-R-766 Appendix A, Section 3.3.3 paragraphs 2, 3, 4, 5 and 6.

When tests are interrupted to allow PD readings to be taken (see paragraph 6) time on load should not exceed two seconds to avoid excessive stress relaxation at the crack tip. The exact method used, including hold times and data collection sequences, must be reported.

2.7 Displacement measurement

Laboratories with the ability to measure front face or load line displacement are requested to report such results in addition to PD values. This is not mandatory. Full details of the method used should be reported.

2.8 Post failure examination

Allow the specimen to cool and separate the two halves of the CT specimen under tensile loading. Take an optical photograph of the complete fracture surface (×10). The final crack length and shape will be clearly visible due to oxidation.

Examine the fracture surfaces and assess the predominant mode of fatigue crack growth at high temperature.

If an SEM is available, a detailed fractographic analysis should be carried out. Three SEM images (×500) to be recorded for each specimen at positions on the fracture surface corresponding to approximate stress intensity factor

levels of 20, 30 and 50 MPa/m. This is not mandatory.

2.9 Retention of specimens

Specimens should be stored in a dry atmosphere so that further post test examination can be carried out if found necessary.

3.0 Presentation of Results

As AGARD-R-766 Appendix A, Section 4:

1. Specimen number
2. da/dN v ΔK curve (graphical paper supplied)
3. 50 data sets (a_i v N_i)
4. Additional comments as necessary

Plus — for IN718 tests

5. 50 data sets of raw data (corresponding to 3) V_+ , V_{ref+} , N , T , T_{ref} , D_{fl} or D_{ff}^* where:
 - D_{fl} = load line displacement
 - D_{ff} = front face displacement
 - T = specimen temperature
 - T_{ref} = reference block temperature

+ — Where pulsed DC is used, voltages should be given for both the current on and current off conditions

* — Not mandatory

6. Fractographic results

APPENDIX 3

GUIDELINES FOR AGARD-SMP WG26 STRAIN CONTROLLED LCF TESTING

Introduction

The Guidelines have been prepared to ensure consistency of testing and reporting in the strain controlled low cycle fatigue testing programme carried out under AGARD WG26. They are in two parts. The first gives details of the materials and test conditions and the second the required data and the details of the testing procedure that should be reported. Annexe 1 defines the symbols and the relationships between the parameters.

Note: Particular attention should be paid to all aspects of calibration of measuring instruments (load cells, extensometers, thermocouples) and to the estimation of the uncertainties associated with the measurements.

Part 1 — Materials and Test Conditions

1.1 Alloys and test temperatures

Alloy	Cyclic deformation characteristics	Test temperature °C
Ti-6Al-4V	softening	room temp.
IN718	softening	600°C ± 2

Materials will be supplied either as finished specimens or as heat-treated blanks for specimen preparation by participants.

1.2 Specimen

If using own design of specimen:

Preparation — machine or grind as appropriate, avoiding overheating or introducing significant surface strains.

Surface finish — Ra 0.3 μm . Longitudinally polished over gauge length.

1.3 Alignment

The maximum allowed bending strain must not exceed 5% of the minimum axial strain range applied during the test programme.

1.4 Heating up schedule

The test should be commenced not less than one hour and not more than 24 hours after the specimen temperature has reached the test temperature.

1.5 Test parameters

- a. Control mode total strain
- b. Cycle shape triangular
- c. Strain ratio (min strain/max strain) -1
- d. Frequency 10 cpm
- e. Initial load (first quarter cycle) tensile
- f. Strain ranges:

Alloy	Total strain ranges, mm/mm		
Ti-6Al-4V	0.02	0.013	0.01
IN718	0.02	0.012	0.008

1.6 Number of tests

Two specimens to be tested at each of the three agreed strain ranges for IN718. For the Ti-6Al-4V validation testing, conduct one test at the largest strain range and one at the lowest. If the third specimen has not been required it may be used for the intermediate strain range.

1.7 Temperature measurement

For radiant heating (furnaces) the temperature should be measured by Pt/Pt-13%Rh thermocouples tied to the gauge length. At least two thermocouples should be used to establish that the temperature is uniform (within 5°C) over the gauge length. The actual temperature of the specimen must be monitored and recorded throughout the test.

Thermocouples should be tied to the specimen using glass fibre or refrasil string passing through the wires behind the bead and then wrapped round the specimen and over the bead to protect it from radiant heat.

1.8 Initial system check

Cycle specimen between ± 300 MPa in load control whilst at room temperature and check (i) that the load extension curve is straight (ii) that the modulus is acceptable.

For the IN718 specimens repeat the above when the furnace has stabilised at 660°C.

Youngs modulus at 20°C:	IN718	approx 205 GPa
	Ti-6Al-4V	approx 120 GPa

1.9 Recording of data and test termination

Sufficient records should be obtained to allow presentation of the data as indicated in Part 2 of this Guideline and to permit the retrospective application of different failure criteria for comparative purposes. Consequently, testing should be continued to specimen fracture or until the tensile load has decreased by 50% of the maximum tensile load observed during the test. Finally, break the specimen at room temperature if not already fractured.

1.10 Post-Failure examination

Examine fracture surface and assess the predominant mode of fatigue cracking at high temperature, eg transgranular, intergranular or mixed (mixed = > 30% of both). Also examine the gauge length for signs of additional cracking.

1.11 Retention of specimens

Specimens should be stored in a dry atmosphere so that further post-test examination can be carried out should this become necessary to elucidate the reasons for differences in mechanical behaviour.

If a defect is found at the initiation site, half the specimen should be returned to the co-ordinator.

Part 2 — Presentation of Test Results

2.1 Specimen description

Drawing of specimen design.

Specimen machining and surface preparation procedures (longitudinal average roughness $R_a = \mu\text{m}$)

2.2 Description of equipment

Testing machine:

Capacity: $\pm \dots \text{kn}$ Range of load: $\dots \text{kN} = 10\text{V}$

Type of actuator:

hydrostatic bearings
teflon bearings
additional guide

Calibration of load measuring system

Heating:

Resistance furnace

Induction

Radiant furnace

Estimation of the axial gradient of temperature over the gauge length: $\pm \dots \text{ }^\circ\text{C}$ (ASTM E 606: $< \pm 2^\circ\text{C}$)

Variation of temperature for the duration of the test:
 $\pm \dots \text{ }^\circ\text{C}$ (ASTM E 606: $< \pm 2^\circ\text{C}$)

Calibration of thermocouples

Extensometry:

Axial:

Description of the extensometer used (sketch-photo)

Direct extensometry:

gauge length: $\dots \text{mm}$
measurement range: $\dots \text{mm}$ for 10V

Indirect extensometry:

describe the calculation of the gauge length and of the strain calibration procedure and results

Specimen fixtures:

Method of ensuring axial loading

Axially-aligned loading bars

Parallel platen grips

Die-set

Liquid metal grips

Other — please specify

2.3 Testing conditions

Alignment

Give details of the method used for checking specimen alignment.

Test parameters

Any difference from prescribed test parameters should be reported.

Describe mode of control, that is, continuous strain control, strain limit control, axial strain feedback, diametral strain feedback, etc.

Recorded values

Evaluation of the modulus of elasticity E:

E_o , by cycling in the elastic domain before test at the test temperature

E_m , from the stress-strain hysteresis loop at mid-life as described in Annexe 1.

Record data:

Load versus time

Extension (command and feedback) versus time

Load versus extension

Temperature versus time

Recorder type

X-Y; $Y_1 - Y_2(t)$; digital voltmeter; peak detector

Supply a copy of the records:

Stress:strain (or load:extension if this not possible) hysteresis loops during the first cycle and at least one other cycle before the 10th cycle. Sufficient further curves should be supplied to fully characterise the stress:strain behaviour throughout the test, eg about 10 loops per test. One of these curves must be at approximately half life ($\pm 10\%$). Ideally one should be the cycle before test termination.

Tensile and compressive stress as a function of accumulated cycles for the complete duration of the test.

Temperature as a function of accumulated cycles for the complete duration of the test.

2.4 Results

The symbols used for the presentation of results are indicated in Annexe 2.

Please supply:

1. A tabulation of the results for all test specimens on form provided.
2. The monotonic stress-strain curves for each test (1st quarter cycle).
3. The half life hysteresis curve plotted as stress v strain for each test.
4. The variation of $\Delta\epsilon_t$, $\Delta\epsilon_e$, $\Delta\epsilon_p$, $\Delta\sigma$, σ_{min} , σ_{max} and T as a function of N for each specimen.
5. The data requested at 2.3.

2.5 Fractography

Please supply:

1. Optical or SEM photograph showing position of crack initiation area compared with the extensometer position.

Where SEM facilities are available:

2. SEM image ($\times 500$) of the initiation area and identification (if possible) of the initiation origin.
3. Image ($\times 200$) of the specimen fracture surface near the initiation area.

2.6 Comments

Complete the information required by comments on your tests including comments on the results of fractographic observations and any additional examinations or metallurgical observations.

Acknowledgement

These guidelines are a direct adaption of those prepared in 1985 by G B Thomas and C Amzallag for an EEC Community Bureau of Reference programme.

ANNEXES TO APPENDIX 3

1. Calculation of modulus at mid life
2. Schematic of data presentation and symbols

APPENDIX 3: ANNEXE 1

Determination of E (Compliance) at Mid-Life

- (a) Take compliance values from the ascending and descending loop branch.
- (b) Define a range $\sigma_1 - \sigma_2$ on the branch, where the compliance is taken as follows (see figure)
 - measured $\Delta\sigma$
 - the range for the descending loop branch is given by $\sigma'_1 = \sigma_{\max} - \Delta\sigma/20$ and $\sigma'_2 = \sigma_1 - \Delta\sigma/3$
 - accordingly for the ascending loop branch $\sigma''_1 = \sigma_{\min} + \Delta\sigma/20$ and $\sigma''_2 = \sigma'_1 + \Delta\sigma/3$
- (c) Carry out a linear regression analysis on the data points between σ_1 and σ_2 (if data are in a digital format) or draw lines covering the slope of the hysteresis loop between σ_1 and σ_2 .

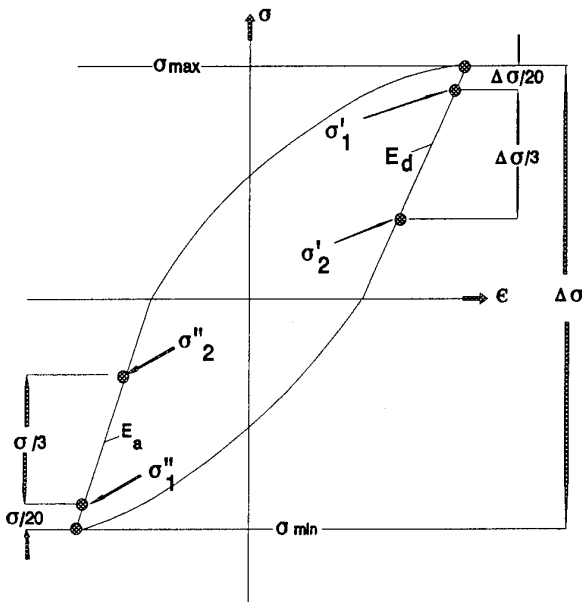

APPENDIX 3: ANNEXE 2

Data Presentation and Symbols

A.1 The experimental data are the following:

- a. the characteristics of the test
 - $\Delta\epsilon_t$ = total strain range, $\epsilon_{\max} - \epsilon_{\min}$
 - $\dot{\epsilon}_t$ = total strain rate

- b. the recordings of tensile load (F_T) and compressive load (c) versus time (or number of cycles)
- c. the recordings of load-displacement loops, continuously in the beginning of the test, then periodically.

A.2 On the continuous recordings of load versus time, the values of F_T and F_C are taken for a sufficient number of cycles over the fatigue life.

These values are used to draw the variation of $\Delta\sigma$, and $\sigma_{\text{mean}}^{\frac{100 \times N}{N_f}}$ versus the number of cycles or the percentage of the life

A.3 The partition of strains is made as follows:

$\Delta\epsilon_p$, imposed during the test, is measured

$\Delta\epsilon_e$, is measured

$\Delta\epsilon_c$, is obtained by difference: $\Delta\epsilon_c = \Delta\epsilon_t - \Delta\epsilon_p$

A.4 Elastic modulus at mid-life

$$E_m = \Delta\sigma / \Delta\epsilon_e$$

A.5 Definition of failure:

There are five possible failure definitions:

- a. total separation or fracture of the specimen into two parts;
- b. a drop in the peak tensile stress of a pre-selected percentage of the maximum peak tensile value during the test;
- c. cusp formation in the compressive portion of the hysteresis loop, such that the size of the cusp has grown to some pre-selected percentage of the peak compressive stress;
- d. a change in the rate-of-change of cyclic load range that exceeds some pre-selected percentage change;
- e. asymmetric load drop (tension load/compression load); ie, a drop in the peak tensile stress that is some pre-selected percentage greater than a corresponding change in the peak compressive stress.

Definition (b) applies correctly only to strain hardening and stable materials. (A pre-selected percentage of 25% was used in the French Round Robin Programme.)

The other definitions can be applied to all material behaviour.

A.6 Symbols:

a) Specimen

l_0 = initial gauge length

$l = l_0(1 + e)$: length for a displacement e

l_u = ultimate length

ϕ_0 = initial diameter

S_0 = initial section

S = section for a displacement e with $S_0 \times l_0 = S \times l$

S_u = ultimate section

b) Low cycle fatigue test

E = modulus of elasticity

ν_e = elastic Poisson's ratio

ν_p = plastic Poisson's ratio

$\dot{\epsilon}_t$ = total strain rate

N_s = number of cycles corresponding to the conventional stabilised cycle

N_x = number of cycles corresponding to a drop of $x\%$ of the maximum load in tension

N_f = number of cycles at fracture of the specimen

$t_f = N_f \times \text{period of the cycle} = \text{time to failure}$

c) **Units**
 Load in N, stress in MPa, strain in mm/mm, length in mm, section in mm², strain rate in s⁻¹.

n, n' : monotonic, cyclic strain hardening exponent

K, K' : monotonic, cyclic strength coefficient

C_e : fatigue strength coefficient

C_p : fatigue ductility coefficient

d) **Functional relationships**

d.1 Stress - strain behaviour

Cyclic: $\sigma_a = K' \times (\epsilon_{pa})^n$

Monotonic: $\sigma_{a0} = K \times (\epsilon_{pa0})^n$

d.2 Fatigue - life relationships

$\Delta\epsilon_p = C_p \times N_f^{-m}$

$\Delta\epsilon_e = C_e \times N_f^{-p}$

where the variables ϵ_{pa} , ϵ_{pa0} , $\Delta\epsilon_p$, $\Delta\epsilon_e$ were defined previously and the constants are:

APPENDIX 4

Tabulated Strain Control LCF Data by Laboratory

- a. NADC 3
- b. PISA 2
- c. KETA 1
- d. CNR/ITM 3
- e. IABG 3
- f. RAE 9
- g. IAR/NRC 3

Values corresponding to the "stabilised" cycle $N = N_s$	F_T, σ_T : maximum load, stress in tension F_c, σ_c : maximum load, stress in compression with $\sigma = F/S$
	<hr/> $\Delta\sigma = \sigma_T + \sigma_c$ = stress range $\sigma_a = \Delta\sigma/2$ = stress amplitude $\sigma_{mean} = (\sigma_T - \sigma_c)/2$ = mean stress value <hr/> $\Delta\epsilon_t$ = total strain range $\Delta\epsilon_e$ = elastic strain range = $\Delta\epsilon_t - \Delta\epsilon_p$ $\Delta\epsilon_p$ = plastic strain range = width of the cycle at zero load $\epsilon_a = (\Delta\epsilon)/2$ = strain amplitude
Values corresponding to the first quarter of cycle $N = 1/4$	σ_{a0} = stress ϵ_{pa0} = plastic strain

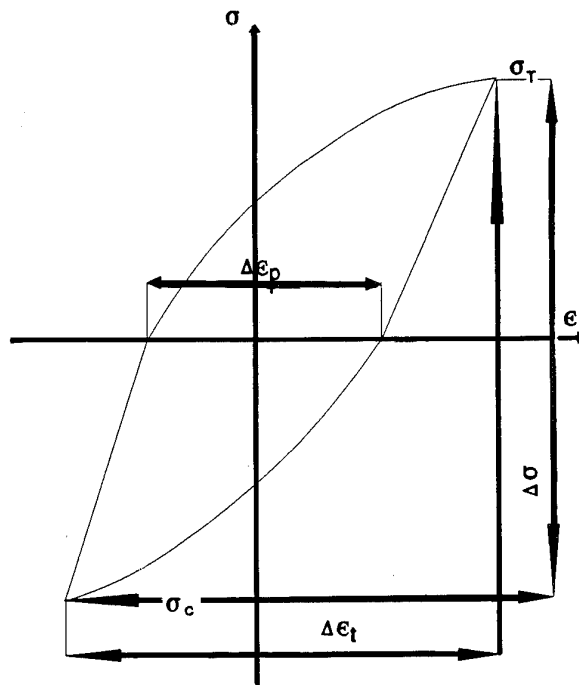

AGARD WC26 - CONSTANT AMPLITUDE LOW-CYCLE FATIGUE TEST RESULTS

CONTROL MODE : EXTENSION

MATERIAL: Ti 6Al 4V

LOADING CYCLE: 10 cpm Triangular R - -1

TEMPERATURE (°C): 20

Specimen Ref. No.	Values at mid life cycle N_x						Values at 1/4 cycle		Endurance (cycles)		Modulus of Elasticity		location of failure ***
	Strain Range			Stress (MPa)			Stress (MPa) σ_m	Plastic strain ϵ_{p0}	N_r	N_x	First cycle E_0 (GPa)	mid life E_m (GPa)	
	Total Strain $\Delta \epsilon_T$	Plastic Strain $\Delta \epsilon_p$	Elastic Strain $\Delta \epsilon_E$	Tensile σ_T	Compress. σ_C	Range $\Delta \sigma$							
RR3	1.95	0.47	1.48	851	897	1749	903		877		120	115	1
RR4	0.99	0.00	0.99	621	608	1229	587+			26340	122	122	1
RR2	1.30	0.08	1.22	816	649	1466	769	0.00023	4485				1

* N_x Number of cycles corresponding to drop of x % relative to σ_r max
 ** Location of failure (S = subsurface)
 (1) Inside gauge length
 (2) At knife edge
 (3) Outside gauge length
 (4) Did not fail

TEST LABORATORY NADC

DATE 21/09/90
 TINADCI.ECF

suggest low 3rd cycl

AGARD WG26 - CONSTANT AMPLITUDE LOW-CYCLE FATIGUE TEST RESULTS

MATERIAL: Ti-6Al-4V

CONTROL MODE : EXTENSION

TEMPERATURE (°C): 21

LOADING CYCLE: 10 cpm Triangular R = -1

Specimen Ref. No.	Values at mid life cycle N_x						Values at 1/4 cycle		Endurance (cycles)		Modulus of Elasticity		location of failure **
	Strain Range			Stress (MPa)			Stress (MPa) σ_{∞}	Plastic strain ϵ_{p0}	N_r	N_x	First cycle E_0 (GPa)	mid life E_m (GPa)	
	Total Strain $\Delta \epsilon_T$	Plastic Strain $\Delta \epsilon_p$	Elastic Strain $\Delta \epsilon_E$	Tensile σ_T	Compress. σ_C	Range $\Delta \sigma$							
RR10	2.08	0.598	1.48	895	-996	1891			470	*	118.02		
RR12	1.34	0.100	1.24						4360		122.0		

* N_x Number of cycles corresponding to drop of x% relative to σ_1 max
 ** Location of failure (S = subsurface)
 (1) Inside gauge length
 (2) At knife edge
 (3) Outside gauge length
 (4) Did not fail

AGARD WG26 - CONSTANT AMPLITUDE LOW-CYCLE FATIGUE TEST RESULTS

CONTROL MODE : EXTENSION

MATERIAL: Ti 6Al 4V

LOADING CYCLE: 10 cpm Triangular R = -1

TEMPERATURE (°C): 20

Specimen Ref. No.	Values at mid life cycle N_x						Values at 1/4 cycle		Endurance (cycles)		Modulus of Elasticity		location of failure **
	Strain Range			Stress (MPa)			Stress (MPa) $\sigma_{1/4}$	Plastic strain $\epsilon_{p1/4}$	N_f	N_x *	First cycle E_o (GPa)	mid life E_m (GPa)	
	Total Strain $\Delta \epsilon_T$	Plastic Strain $\Delta \epsilon_p$	Elastic Strain $\Delta \epsilon_e$	Tensile σ_T	Compress. σ_C	Range $\Delta \sigma$							
RAE2	0.995	0.000	0.995	633	597	1230	732	0.000	17579	*	123	123	
RAE3	1.077	0.000	1.077	637	665	1302	628	0.000	12643		122	121	
RAE6	1.154	0.005	1.149	675	720	1395	688	0.000	10376		123	120	
RAE4	1.496	0.138	1.362	811	852	1663	862	0.050	1995		119	118	
RAE1	1.979	0.616	1.363	829	887	1716	975	0.200	923		113	116	
RR8	1.939	0.582	1.357	825	950	1784	964	0.200	484		128		

* N_x Number of cycles corresponding to drop of x % relative to σ_1 max

** Location of failure (S = subsurface)

(1) Inside gauge length

(2) At knife edge

(3) Outside gauge length

(4) Did not fail

TEST LABORATORY RAE PROPULSION

DATE 04/10/90

T1RAEP1.ECF

AGARD WG26 - CONSTANT AMPLITUDE LOW-CYCLE FATIGUE TEST RESULTS

CONTROL MODE : EXTENSION

MATERIAL: Ti 6Al 4V

LOADING CYCLE: 10 cpm Triangular

TEMPERATURE (°C): 21

Specimen Ref. No.	Values at mid life cycle N_x						Values at 1/4 cycle		Endurance (cycles)		Modulus of Elasticity		location of failure
	Strain Range			Stress (MPa)			Stress (MPa) σ_w	Plastic strain ϵ_{pwo}	N_r	N_x	First cycle E_o (GPa)	mid life E_m (GPa)	
	Total Strain $\Delta \epsilon_T$	Plastic Strain $\Delta \epsilon_P$	Elastic Strain $\Delta \epsilon_E$	Tensile σ_T	Compress. σ_C	Range $\Delta \sigma$							
RAE12	1.992	0.52	1.472	866.8	-897.5	1764.4	840.2	0.21%	927	*	115.5	121.05	1
RAE7	1.992	0.556	1.437	806.2	-723	1529	842	0.125%	668		105.4		1
RAE5	1.293	0.029	1.264	750.0	-765	1513.4	760.9	0.00	5345		116.0	117.55	2

* N_x Number of cycles corresponding to drop of x.% relative to σ_1 max
 ** Location of failure (S = subsurface)
 (1) Inside gauge length
 (2) At knife edge
 (3) Outside gauge length
 (4) Did not fail

TEST LABORATORY RAE PROPULSION

DATE 27/7/91
 TIRAEP2.ECF

AGARD WC26 - CONSTANT AMPLITUDE LOW-CYCLE FATIGUE TEST RESULTS

CONTROL MODE : EXTENSION

MATERIAL: Ti-6Al-4V

LOADING CYCLE: 10 cpm

TEMPERATURE (°C): 20

Specimen Ref. No.	Values at mid life cycle N_x						Values at 1/4 cycle		Endurance (cycles)		Modulus of Elasticity		location of failure **
	Strain Range			Stress (MPa)			Plastic strain ϵ_{p0}	N_r	N_x	First cycle E_0 (GPa)	mid life E_m (GPa)		
	Total Strain $\Delta \epsilon_T$	Plastic Strain $\Delta \epsilon_P$	Elastic Strain $\Delta \epsilon_E$	Tensile σ_T	Compress. σ_C	Range $\Delta \sigma$							
ITM3	1.0		1.0	575	559	1134	546	24440	*	125	115	1	
ITM1	1.3		1.3	734	740	1474	701	7020				1	
ITM2	2.0	1.0	1.0	870	1011	1811	1396	600				1	

* N_x Number of cycles corresponding to drop of $x\%$ relative to σ_r max
 ** Location of failure (S = subsurface)
 (1) Inside gauge length
 (2) At knife edge
 (3) Outside gauge length
 (4) Did not fail

TEST LABORATORY ITM

DATE
TITM1.ECF

AGARD WG26 - CONSTANT AMPLITUDE LOW-CYCLE FATIGUE TEST RESULTS

MATERIAL: Ti-6Al-4V

CONTROL MODE : EXTENSION

TEMPERATURE (°C): 21

LOADING CYCLE: 10 cpm Triangular R = -1

Specimen Ref. No.	Values at mid life cycle N_x						Values at 1/4 cycle		Endurance (cycles)		Modulus of Elasticity		location of failure **
	Strain Range			Stress (MPa)			Stress (MPa) σ_m	Plastic strain ϵ_{p0}	N_r	N_x	First cycle E_o (GPa)	mid life E_m (GPa)	
	Total Strain $\Delta \epsilon_T$	Plastic Strain $\Delta \epsilon_P$	Elastic Strain $\Delta \epsilon_E$	Tensile σ_T	Compress. σ_C	Range $\Delta \sigma$							
IABG1	2.00	0.578	1.422	798	-840	1638	948	0.205	788	786	118.3	118.50	1
IABG2	1.30	0.040	1.260	748	-758	1506	790	0.000	13263	13073	118.3	121.65	1
IABG3	1.00	0.000	1.000	611	-595	1206	597	0.000	41120	-	118.3	120.80	4

* N_x Number of cycles corresponding to drop of x % relative to σ_1 max
 ** Location of failure (S = subsurface)
 (1) Inside gauge length
 (2) At knife edge
 (3) Outside gauge length
 (4) Did not fail

TEST LABORATORY IABG
 DATE
 Filename TIMABG1.ECF

REPORT DOCUMENTATION PAGE

1. Recipient's Reference	2. Originator's Reference AGARD-AR-328	3. Further Reference ISBN 92-835-0716-9	4. Security Classification of Document UNCLASSIFIED/ UNLIMITED
5. Originator	Advisory Group for Aerospace Research and Development North Atlantic Treaty Organization 7 Rue Ancelle, 92200 Neuilly sur Seine, France		
6. Title	HIGH TEMPERATURE CYCLIC BEHAVIOUR OF AEROSPACE MATERIALS: ROOM TEMPERATURE VALIDATION TESTS OF Ti-6Al-4V		
7. Presented at			
8. Author(s)/Editor(s) C. Wilkinson and C.R. Gostelow	9. Date June 1994		
10. Author's/Editor's Address Defence Research Agency Materials and Structures Department RAE Pyestock, Farnborough, Hants, U.K.	11. Pages 34		
12. Distribution Statement	There are no restrictions on the distribution of this document. Information about the availability of this and other AGARD unclassified publications is given on the back cover.		
13. Keywords/Descriptors Titanium alloys Thermal cycling tests Crack Propagation Validity	Fatigue — materials Aluminum containing alloys Vanadium containing alloys		
14. Abstract	<p>Materials specification and distribution of Ti-6Al-4V specimens are presented along with the collated data from those participants that have supplied test results. Crack propagation and strain control low cycle fatigue data are discussed, along with a number of points of clarification regarding test technique.</p> <p>This report, sponsored by the Structures and Materials Panel of AGARD, contains all relevant information on the validation exercise conducted by participants of Working Group 26.</p>		

<p>AGARD Advisory Report 328 Advisory Group for Aerospace Research and Development, NATO HIGH TEMPERATURE CYCLIC BEHAVIOUR OF AEROSPACE MATERIALS: ROOM TEMPERATURE VALIDATION TESTS OF Ti-6Al-4V By C. Wilkinson and C.R. Gostelow Published June 1994 34 pages</p> <p>Materials specification and distribution of Ti-6Al-4V specimens are presented along with the collated data from those participants that have supplied test results. Crack propagation and strain control low cycle fatigue data are discussed, along with a number of points of clarification regarding test technique.</p> <p>P.T.O.</p>	<p>AGARD-AR-328</p> <p>Titanium alloys Thermal cycling tests Crack propagation Validity Fatigue — materials Aluminum containing alloys Vanadium containing alloys</p>	<p>AGARD Advisory Report 328 Advisory Group for Aerospace Research and Development, NATO HIGH TEMPERATURE CYCLIC BEHAVIOUR OF AEROSPACE MATERIALS: ROOM TEMPERATURE VALIDATION TESTS OF Ti-6Al-4V By C. Wilkinson and C.R. Gostelow Published June 1994 34 pages</p> <p>Materials specification and distribution of Ti-6Al-4V specimens are presented along with the collated data from those participants that have supplied test results. Crack propagation and strain control low cycle fatigue data are discussed, along with a number of points of clarification regarding test technique.</p> <p>P.T.O.</p>	<p>AGARD-AR-328</p> <p>Titanium alloys Thermal cycling tests Crack propagation Validity Fatigue — materials Aluminum containing alloys Vanadium containing alloys</p>
<p>AGARD Advisory Report 328 Advisory Group for Aerospace Research and Development, NATO HIGH TEMPERATURE CYCLIC BEHAVIOUR OF AEROSPACE MATERIALS: ROOM TEMPERATURE VALIDATION TESTS OF Ti-6Al-4V By C. Wilkinson and C.R. Gostelow Published June 1994 34 pages</p> <p>Materials specification and distribution of Ti-6Al-4V specimens are presented along with the collated data from those participants that have supplied test results. Crack propagation and strain control low cycle fatigue data are discussed, along with a number of points of clarification regarding test technique.</p> <p>P.T.O.</p>	<p>AGARD-AR-328</p> <p>Titanium alloys Thermal cycling tests Crack propagation Validity Fatigue — materials Aluminum containing alloys Vanadium containing alloys</p>	<p>AGARD Advisory Report 328 Advisory Group for Aerospace Research and Development, NATO HIGH TEMPERATURE CYCLIC BEHAVIOUR OF AEROSPACE MATERIALS: ROOM TEMPERATURE VALIDATION TESTS OF Ti-6Al-4V By C. Wilkinson and C.R. Gostelow Published June 1994 34 pages</p> <p>Materials specification and distribution of Ti-6Al-4V specimens are presented along with the collated data from those participants that have supplied test results. Crack propagation and strain control low cycle fatigue data are discussed, along with a number of points of clarification regarding test technique.</p> <p>P.T.O.</p>	<p>AGARD-AR-328</p> <p>Titanium alloys Thermal cycling tests Crack propagation Validity Fatigue — materials Aluminum containing alloys Vanadium containing alloys</p>

<p>This report, sponsored by the Structures and Materials Panel of AGARD, contains all relevant information on the validation exercise conducted by participants of Working Group 26.</p> <p>ISBN 92-835-0716-9</p>	<p>This report, sponsored by the Structures and Materials Panel of AGARD, contains all relevant information on the validation exercise conducted by participants of Working Group 26.</p> <p>ISBN 92-835-0716-9</p>
<p>This report, sponsored by the Structures and Materials Panel of AGARD, contains all relevant information on the validation exercise conducted by participants of Working Group 26.</p> <p>ISBN 92-835-0716-9</p>	<p>This report, sponsored by the Structures and Materials Panel of AGARD, contains all relevant information on the validation exercise conducted by participants of Working Group 26.</p> <p>ISBN 92-835-0716-9</p>

AGARD

NATO  OTAN

7 RUE ANCELLE · 92200 NEUILLY-SUR-SEINE

FRANCE

Télécopie (1)47.38.57.99 · Téléc 610 176

DIFFUSION DES PUBLICATIONS

AGARD NON CLASSIFIEES

Aucun stock de publications n'a existé à AGARD. A partir de 1993, AGARD détiendra un stock limité des publications associées aux cycles de conférences et cours spéciaux ainsi que les AGARDographies et les rapports des groupes de travail, organisés et publiés à partir de 1993 inclus. Les demandes de renseignements doivent être adressées à AGARD par lettre ou par fax à l'adresse indiquée ci-dessus. *Veillez ne pas téléphoner.* La diffusion initiale de toutes les publications de l'AGARD est effectuée auprès des pays membres de l'OTAN par l'intermédiaire des centres de distribution nationaux indiqués ci-dessous. Des exemplaires supplémentaires peuvent parfois être obtenus auprès de ces centres (à l'exception des Etats-Unis). Si vous souhaitez recevoir toutes les publications de l'AGARD, ou simplement celles qui concernent certains Panels, vous pouvez demander à être inclut sur la liste d'envoi de l'un de ces centres. Les publications de l'AGARD sont en vente auprès des agences indiquées ci-dessous, sous forme de photocopie ou de microfiche.

CENTRES DE DIFFUSION NATIONAUX

ALLEMAGNE

Fachinformationszentrum,
Karlsruhe
D-7514 Eggenstein-Leopoldshafen 2

BELGIQUE

Coordonnateur AGARD-VSL
Etat-Major de la Force Aérienne
Quartier Reine Elisabeth
Rue d'Evere, 1140 Bruxelles

CANADA

Directeur du Service des Renseignements Scientifiques
Ministère de la Défense Nationale
Ottawa, Ontario K1A 0K2

DANEMARK

Danish Defence Research Establishment
Ryvangs Allé 1
P.O. Box 2715
DK-2100 Copenhagen Ø

ESPAGNE

INTA (AGARD Publications)
Pintor Rosales 34
28008 Madrid

ETATS-UNIS

NASA Headquarters
Attention: CF 37, Distribution Center
300 E Street, S.W.
Washington, D.C. 20546

FRANCE

O.N.E.R.A. (Direction)
29, Avenue de la Division Leclerc
92322 Châtillon Cedex

GRECE

Hellenic Air Force
Air War College
Scientific and Technical Library
Dekelia Air Force Base
Dekelia, Athens TGA 1010

ISLANDE

Director of Aviation
c/o Flugrad
Reykjavik

ITALIE

Aeronautica Militare
Ufficio del Delegato Nazionale all'AGARD
Aeroporto Pratica di Mare
00040 Pomezia (Roma)

LUXEMBOURG

Voir Belgique

NORVEGE

Norwegian Defence Research Establishment
Attn: Biblioteket
P.O. Box 25
N-2007 Kjeller

PAYS-BAS

Netherlands Delegation to AGARD
National Aerospace Laboratory NLR
P.O. Box 90502
1006 BM Amsterdam

PORTUGAL

Força Aérea Portuguesa
Centro de Documentação e Informação
Alfragide
2700 Amadora

ROYAUME UNI

Defence Research Information Centre
Kentigern House
65 Brown Street
Glasgow G2 8EX

TURQUIE

Millî Savunma Başkanlığı (MSB)
ARGE Daire Başkanlığı (ARGE)
Ankara

Le centre de distribution national des Etats-Unis ne détient PAS de stocks des publications de l'AGARD.

D'éventuelles demandes de photocopies doivent être formulées directement auprès du NASA Center for Aerospace Information (CASI) à l'adresse suivante:

AGENCES DE VENTE

NASA Center for
Aerospace Information (CASI)
800 Elkridge Landing Road
Linthicum Heights, MD 21090-2934
United States

ESA/Information Retrieval Service
European Space Agency
10, rue Mario Nikis
75015 Paris
France

The British Library
Document Supply Division
Boston Spa, Wetherby
West Yorkshire LS23 7BQ
Royaume Uni

Les demandes de microfiches ou de photocopies de documents AGARD (y compris les demandes faites auprès du CASI) doivent comporter la dénomination AGARD, ainsi que le numéro de série d'AGARD (par exemple AGARD-AG-315). Des informations analogues, telles que le titre et la date de publication sont souhaitables. Veuillez noter qu'il y a lieu de spécifier AGARD-R-*nnn* et AGARD-AR-*nnn* lors de la commande des rapports AGARD et des rapports consultatifs AGARD respectivement. Des références bibliographiques complètes ainsi que des résumés des publications AGARD figurent dans les journaux suivants:

Scientific and Technical Aerospace Reports (STAR)
publié par la NASA Scientific and Technical
Information Program
NASA Headquarters (JTT)
Washington D.C. 20546
Etats-Unis

Government Reports Announcements and Index (GRA&I)
publié par le National Technical Information Service
Springfield
Virginia 22161
Etats-Unis
(accessible également en mode interactif dans la base de
données bibliographiques en ligne du NTIS, et sur CD-ROM)



Imprimé par *Specialised Printing Services Limited*
40 Chigwell Lane, Loughton, Essex IG10 3TZ

AGARD

NATO  OTAN

7 RUE ANCELLE · 92200 NEUILLY-SUR-SEINE

FRANCE

Telefax (1)47.38.57.99 · Telex 610 176

DISTRIBUTION OF UNCLASSIFIED

AGARD PUBLICATIONS

AGARD holds limited quantities of the publications that accompanied Lecture Series and Special Courses held in 1993 or later, and of AGARDographs and Working Group reports published from 1993 onward. For details, write or send a telefax to the address given above. *Please do not telephone.*

AGARD does not hold stocks of publications that accompanied earlier Lecture Series or Courses or of any other publications. Initial distribution of all AGARD publications is made to NATO nations through the National Distribution Centres listed below. Further copies are sometimes available from these centres (except in the United States). If you have a need to receive all AGARD publications, or just those relating to one or more specific AGARD Panels, they may be willing to include you (or your organisation) on their distribution list. AGARD publications may be purchased from the Sales Agencies listed below, in photocopy or microfiche form.

NATIONAL DISTRIBUTION CENTRES

BELGIUM

Coordonnateur AGARD — VSL
Etat-Major de la Force Aérienne
Quartier Reine Elisabeth
Rue d'Evere, 1140 Bruxelles

CANADA

Director Scientific Information Services
Dept of National Defence
Ottawa, Ontario K1A 0K2

DENMARK

Danish Defence Research Establishment
Ryvangs Allé 1
P.O. Box 2715
DK-2100 Copenhagen Ø

FRANCE

O.N.E.R.A. (Direction)
29 Avenue de la Division Leclerc
92322 Châtillon Cedex

GERMANY

Fachinformationszentrum
Karlsruhe
D-7514 Eggenstein-Leopoldshafen 2

GREECE

Hellenic Air Force
Air War College
Scientific and Technical Library
Dekelia Air Force Base
Dekelia, Athens TGA 1010

ICELAND

Director of Aviation
c/o Flugrad
Reykjavik

ITALY

Aeronautica Militare
Ufficio del Delegato Nazionale all'AGARD
Aeroporto Pratica di Mare
00040 Pomezia (Roma)

LUXEMBOURG

See Belgium

NETHERLANDS

Netherlands Delegation to AGARD
National Aerospace Laboratory, NLR
P.O. Box 90502
1006 BM Amsterdam

NORWAY

Norwegian Defence Research Establishment
Attn: Biblioteket
P.O. Box 25
N-2007 Kjeller

PORTUGAL

Força Aérea Portuguesa
Centro de Documentação e Informação
Alfragide
2700 Amadora

SPAIN

INTA (AGARD Publications)
Pintor Rosales 34
28008 Madrid

TURKEY

Milli Savunma Başkanlığı (MSB)
ARGE Daire Başkanlığı (ARGE)
Ankara

UNITED KINGDOM

Defence Research Information Centre
Kentigern House
65 Brown Street
Glasgow G2 8EX

UNITED STATES

NASA Headquarters
Attention: CF 37, Distribution Center
300 E Street, S.W.
Washington, D.C. 20546

The United States National Distribution Centre does NOT hold stocks of AGARD publications.

Applications for copies should be made direct to the NASA Center for Aerospace Information (CASI) at the address below.

SALES AGENCIES

NASA Center for
Aerospace Information (CASI)
800 Elkridge Landing Road
Linthicum Heights, MD 21090-2934
United States

ESA/Information Retrieval Service
European Space Agency
10, rue Mario Nikis
75015 Paris
France

The British Library
Document Supply Centre
Boston Spa, Wetherby
West Yorkshire LS23 7BQ
United Kingdom

Requests for microfiches or photocopies of AGARD documents (including requests to CASI) should include the word 'AGARD' and the AGARD serial number (for example AGARD-AG-315). Collateral information such as title and publication date is desirable. Note that AGARD Reports and Advisory Reports should be specified as AGARD-R-*nnn* and AGARD-AR-*nnn*, respectively. Full bibliographical references and abstracts of AGARD publications are given in the following journals:

Scientific and Technical Aerospace Reports (STAR)
published by NASA Scientific and Technical
Information Program
NASA Headquarters (JTT)
Washington D.C. 20546
United States

Government Reports Announcements and Index (GRA&I)
published by the National Technical Information Service
Springfield
Virginia 22161
United States
(also available online in the NTIS Bibliographic
Database or on CD-ROM)



Printed by Specialised Printing Services Limited
40 Chigwell Lane, Loughton, Essex IG10 3TZ