

# NAVAL POSTGRADUATE SCHOOL MONTEREY, CALIFORNIA



## THESIS

**SEAKEEPING ASPECTS OF SLICE HULLS**  
by

**Stephen B. Peffers**

**March 1995**

**Thesis Advisor:**

**Fotis A. Papoulias**

**Approved for public release; distribution is unlimited.**

19950606 030

**DTIC QUALITY INSPECTED 3**

# DISCLAIMER NOTICE

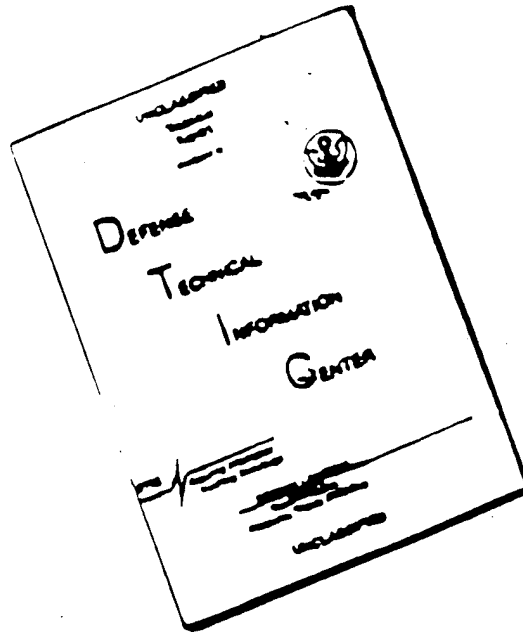

THIS DOCUMENT IS BEST  
QUALITY AVAILABLE. THE COPY  
FURNISHED TO DTIC CONTAINED  
A SIGNIFICANT NUMBER OF  
PAGES WHICH DO NOT  
REPRODUCE LEGIBLY.

# REPORT DOCUMENTATION PAGE

Form Approved OMB No. 0704-0188

Public reporting burden for this collection of information is estimated to average 1 hour per response, including the time for reviewing instruction, searching existing data sources, gathering and maintaining the data needed, and completing and reviewing the collection of information. Send comments regarding this burden estimate or any other aspect of this collection of information, including suggestions for reducing this burden, to Washington Headquarters Services, Directorate for Information Operations and Reports, 1215 Jefferson Davis Highway, Suite 1204, Arlington, VA 22202-4302, and to the Office of Management and Budget, Paperwork Reduction Project (0704-0188) Washington DC 20503.

1. AGENCY USE ONLY <i>(Leave blank)</i>	2. REPORT DATE March 1995	3. REPORT TYPE AND DATES COVERED Master's Thesis	
4. TITLE AND SUBTITLE SEAKEEPING ASPECTS OF SLICE HULLS		5. FUNDING NUMBERS	
6. AUTHOR(S) Peffer, Stephen		8. PERFORMING ORGANIZATION REPORT NUMBER	
7. PERFORMING ORGANIZATION NAME(S) AND ADDRESS(ES) Naval Postgraduate School Monterey CA 93943-5000		10. SPONSORING/MONITORING AGENCY REPORT NUMBER	
9. SPONSORING/MONITORING AGENCY NAME(S) AND ADDRESS(ES)		11. SUPPLEMENTARY NOTES The views expressed in this thesis are those of the author and do not reflect the official policy or position of the Department of Defense or the U.S. Government.	
12a. DISTRIBUTION/AVAILABILITY STATEMENT Approved for public release; distribution is unlimited.		12b. DISTRIBUTION CODE	
13. ABSTRACT <i>(maximum 200 words)</i> *  Seakeeping calculations are performed for a new hull design, SLICE. This hull type is a variation of a Small Waterplane Twin Hull (SWATH) ship, with the primary difference of discontinuous fore and aft buoyancy pods. Emphasis in this work is placed on understanding the applicability and limitations of a standard strip theory approach to coupled heave and pitch motions in regular and random seas. It is shown that the coupled pitch and heave natural periods change with forward speed and wave direction, unlike the SWATH case where the uncoupled heave natural period remains approximately constant. The results of this study indicate that the problem of resonant frequencies between the port and starboard pods does not appear to limit the applicability of two-dimensional hydrodynamic calculations, while the use of potential flow theory underestimates heave and pitch damping for SLICE hulls.			
14. SUBJECT TERMS Hydrodynamic Coefficients, Heave and Pitch natural frequencies		15. NUMBER OF PAGES 108	
		16. PRICE CODE	
17. SECURITY CLASSIFICATION OF REPORT Unclassified	18. SECURITY CLASSIFICATION OF THIS PAGE Unclassified	19. SECURITY CLASSIFICATION OF ABSTRACT Unclassified	20. LIMITATION OF ABSTRACT UL

NSN 7540-01-280-5500 Standard Form 298 (Rev. 289) Prescribed by ANSI Std. Z39-18 298-102



Approved for public release; distribution is unlimited.

## SEAKEEPING ASPECTS OF SLICE HULLS

Stephen B. Peffers  
Lieutenant Commander, United States Navy  
B.S., United States Naval Academy, 1984

Submitted in partial fulfillment  
of the requirements for the degree of

**MASTER OF SCIENCE IN MECHANICAL ENGINEERING**  
from the  
**NAVAL POSTGRADUATE SCHOOL**  
March 1995

Author:

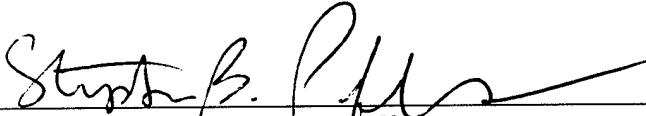
  
Stephen B. Peffers

Approved by:

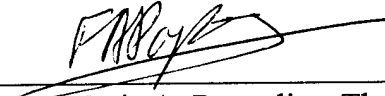
  
Fotis A. Papoulias, Thesis Advisor

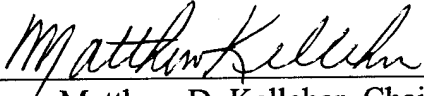
  
Matthew D. Kelleher, Chairman  
Department of Mechanical Engineering

Accession For	
NTIS CRA&I	<input checked="" type="checkbox"/>
DTIC TAB	<input type="checkbox"/>
Unannounced	<input type="checkbox"/>
Justification .....	
By .....	
Distribution /	
Availability Codes	
Dist	Avail and/or Special
A-1	



## ABSTRACT

Seakeeping calculations are performed for a new hull design, SLICE. This hull type is a variation of a Small Waterplane Twin Hull (SWATH) ship, with the primary difference of discontinuous fore and aft buoyancy pods. Emphasis in this work is placed on understanding the applicability and limitations of a standard strip theory approach to coupled heave and pitch motions in regular and random seas. It is shown that the coupled pitch and heave natural periods change with forward speed and wave direction, unlike the SWATH case where the uncoupled heave natural period remains approximately constant. The results of this study indicate that the problem of resonant frequencies between the port and starboard pods does not appear to limit the applicability of two-dimensional hydrodynamic calculations, while the use of potential flow theory underestimates heave and pitch damping for SLICE hulls.



## TABLE OF CONTENTS

I. INTRODUCTION.....	1
A. GENERAL.....	1
II. MODELING OF THE SLICE.....	5
A. STRIP THEORY METHOD.....	5
B. SOLVING THE HYDRODYNAMIC COEFFICIENTS.....	6
C. BUILDING THE SLICE MODEL.....	12
III. RESULTS AND DISCUSSION.....	23
A. GENERAL.....	23
B. ADDED MASS AND DAMPING COEFFICIENTS.....	24
1. Sectional Added Mass and Damping Coefficients.....	24
2. Total Added Mass and Damping Coefficients.....	44
C. RESPONSE AMPLITUDE OPERATORS.....	47
1. Different Ship Speeds.....	47
2. Different Wave Directions.....	65
IV. CONCLUSION AND RECOMMENDATIONS.....	89
A. CONCLUSIONS.....	89
B. RECOMMENDATIONS.....	90
APPENDIX: INPUT FILE FOR SHIPMO.BM.....	91
REFERENCES.....	97
INITIAL DISTRIBUTION LIST.....	99

## I. INTRODUCTION

### A. GENERAL

The study of the hydrodynamic properties of any hull design depends on good theoretical analysis that can be validated by model experiments and full scale sea trials. In this paper a computer model was used to predict the hydrodynamic coefficients and motions of a new hull form in different wave conditions and speeds. These results can be validated by comparing them with the vast amount of data that has been collected on a similar hull shape. This new hull form has been designated the SLICE and is shown in Figure 1. The existing hull shape that has been thoroughly tested by the U. S. Navy is the

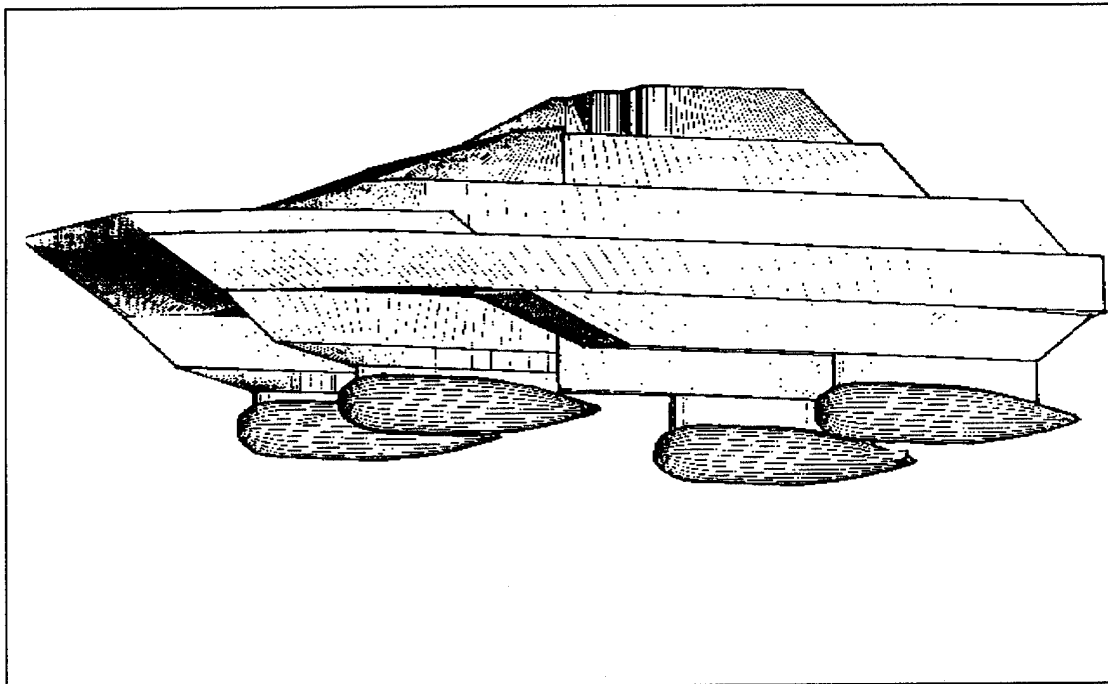

Figure 1. SLICE Hull Design

Small Waterplane Area Twin Hull (SWATH) ship and it is shown in Figure 2.

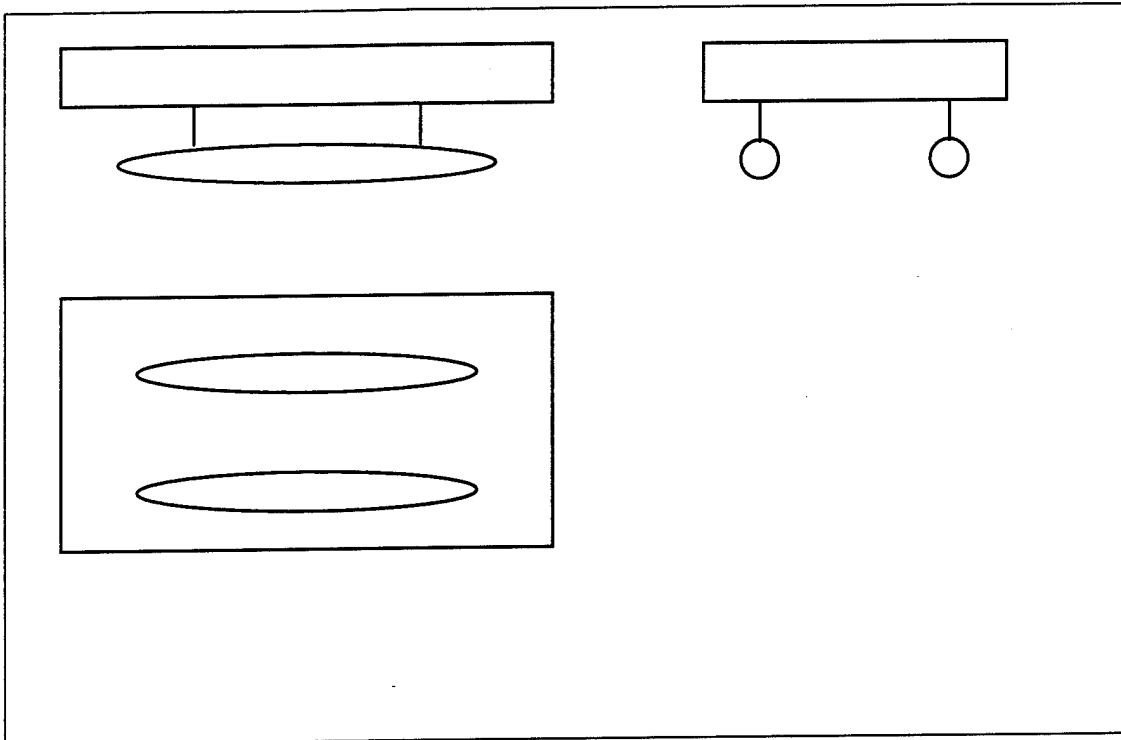

Figure 2. SWATH Hull Design

The similarities between the two hull designs are obvious. The SWATH ships consist of two underwater submarine type hulls which are connected to a main platform area by slender struts. This design greatly reduces the amount of waterplane area required for a ship with the same displacement as a monohull ship. Typically this design requires as little as 20 percent of the waterplane area that have been used for a similar size monohull ship. Since the SWATH design requires less waterplane area and it also lowers the buoyant volume of the ship due to the underwater hulls, this reduces the excitation forces of the waves and makes the natural periods of heave and pitch modes longer. This is a definite advantage over monohull ships because it means that it takes a much longer wave than those found in normal storm conditions to excite a large vertical motion in the

SWATH ship. The SWATH ship also allows for a large amount of flexibility in the design of a specific ship to meet specified guidelines such as operating environment and mission. Given all the advantages of this hull design, there are some minor limitations on these ships, but these problems have been identified and solved. One of the interesting hydrodynamic problems that has occurred because of the small waterplane area is the reduction in vertical stability caused by very little damping supplied by the submerged hulls. To alleviate this problem, active control stabilizing fins are used to provide more stability to the ship. In an effort to reduce the drag resistance of the SWATH, thus improving the fuel efficiency and top speed, a similar hull design has been developed. This new hull design known as the SLICE, is being considered for use as an all-purpose stable platform that can maintain high speeds in various sea states and be more efficient to operate. The SLICE uses the same technology as the SWATH but separates the underwater hull into four submerged pods each connected to the main deck structure. This design will further reduce the waterplane area and the drag of the underwater hulls. In order to try and predict the seakeeping performance and hydrodynamic coefficients of this new hull design, a model of the underwater portion of the hull was developed and used in a computer program that simulates different wave forces, wave direction, and ship speed. Chapter II will explain the computer program that was used and the method of modeling the underwater portion of the SLICE. Chapter III will analyze and discuss the data that was collected from the computer program and predicts the seakeeping performance of the SLICE hull design in various wave directions and speeds. Chapter IV will summarize the results and make recommendations for future analysis of the hydrodynamic properties of the SLICE hull.



## II. MODELING OF THE SLICE

### A. STRIP THEORY METHOD

The computer program used for predicting the hydrodynamic coefficients is a strip theory program called SHIPMO.BM developed by Robert F. Beck and Armin W. Troesch. This program was written in FORTRAN 77 and will calculate many different aspects of ship motion and shear and bending moments at various points, given a wide variety of inputs. I have concentrated on the ship motion results calculated in this program and have only been concerned with those inputs that will affect these results. The methods of calculating the ship motions are based on the strip theory approach of Salvesen, Tuck, and Faltinsen (1970). The calculations were made using both regular waves and irregular waves (using the ISSC Spectrum) in an infinite sea. The calculation of the hydrodynamic coefficients was made assuming a two-dimensional potential flow at each cross section of the ship. The strip theory approach assumes a long slender body and the flow across each of the small sections is relatively constant over the entire hull length. The use of the strip theory is somewhat more difficult on twin or quad hull ships such as the SLICE compared to the work on monohull ships. Three distinct considerations should be included in the hydrodynamic coefficients for this type of ship:

1. Hydrodynamic interactions between the two hulls.
2. The viscous damping effects. This cannot be neglected because for SLICE ships it is of the same order of magnitude as wave making damping. As expected for a lightly damped system, neglect of viscous damping effects would yield unrealistically large motion amplitudes at the resonant frequencies.
3. The effect of stabilizing fins. A SLICE ship may react similar to that of a SWATH, which becomes unstable in the vertical plane, at and beyond a certain speed, because of the small waterplane area, since the SLICE has an even smaller waterplane area. This problem is expected to persist. This instability is mainly caused by a destabilizing pitch moment, often referred to as the Munk moment, which is proportional

to the square of the forward velocity of the body. The use of stabilizing fins helps to restore the stability of the ship. The stabilizing fins can also improve the damping effects to the motion of the ship through the hydrodynamic lift generated by an angle of attack that results from the combination of the forward motion and the vertical motion of the fins.

## B. SOLVING THE HYDRODYNAMIC COEFFICIENTS

The computer program used was programmed to predict these hydrodynamic coefficients for catamaran type hulls that are completely submerged. A brief description of the theoretical method used to calculate the hydrodynamic coefficients is presented. The linear simultaneous equations that must be solved are:

$$\sum_{j=1,2,3,4,5,6} \left\{ -\omega_e^2 (M_{jk} + A_{jk}) + i\omega_e B_{jk} + C_{jk} \right\} \zeta_k = F_j^I + F_j^D \quad (1)$$

$$j = 1,2,3,4,5,6 \quad k = 1,2,3,4,5,6$$

where

- $\zeta_k$  = complex amplitude of motion in the  $k^{\text{th}}$  direction
- $\zeta_1$  = surge
- $\zeta_2$  = sway
- $\zeta_3$  = heave
- $\zeta_4$  = roll
- $\zeta_5$  = pitch
- $\zeta_6$  = yaw
- $M_{jk}$  = mass matrix
- $A_{jk}$  = added mass matrix
- $B_{jk}$  = damping matrix
- $C_{jk}$  = hydrostatic restoring force matrix
- $F_j^I$  = Froude Krylov exciting force in  $j^{\text{th}}$  mode of motion

$F_j^D$  = Diffraction exciting force in  $j^{\text{th}}$  mode of motion

The calculations of the coefficients in the equations of motion are found by using the formulas listed in Tables 1 and 2. The exciting forces are computed by the formulas listed in Table 3. The variables listed in Tables 1,2 and 3,  $a_{jk}$ ,  $b_{jk}$ , and  $\psi_{jk}$ , refer to the two-dimensional added mass, damping and potential coefficients. These quantities are found by solving at each cross section the following boundary value problem:

$$\nabla^2 \psi_k(y,z) = 0 \quad \text{in the fluid domain} \quad (2)$$

subject to

$$-\omega^2 \psi_k + g(\partial \psi_k / \partial z) = 0 \quad \text{on } z = 0 \quad (3)$$

$$\partial \psi_k / \partial N = i\omega_e N_k \quad \text{on body surface} \quad (4)$$

$$\text{Lim } z \rightarrow -\infty \quad \nabla \psi_k \rightarrow 0 \quad \text{for deep water} \quad (5)$$

The sectionals added mass and damping are formed by integrating the potentials over the body boundary as follows:

$$\omega_e^2 a_{jj} - i\omega_e b_{jj} = -\rho i \omega_e \int N_j \psi_j dl \quad j = 1,2,3,4 \quad (6)$$

$$\begin{aligned} \omega_e^2 a_{13} - i\omega_e b_{13} &= \omega_e^2 a_{31} - i\omega_e b_{31} \\ &= -\rho i \omega_e \int N_1 \psi_3 dl \end{aligned} \quad (7)$$

$$\omega_e^2 a_{24} - i\omega_e b_{24} = \omega_e^2 a_{42} - i\omega_e b_{42}$$

$$=-\rho i \omega_e \int N_2 \psi_4 dl \quad (8)$$

For a port and starboard symmetric body with no mooring lines or other outside restraints, the horizontal plane motions are decoupled from the vertical plane motions. Thus, equation (1) may be solved as two sets of three equations for  $j=1,3,5$  and  $j=2,4,6$ . It should be noted that the motion calculations just described are for a slender body in an ideal fluid. To obtain good motion predictions the coefficients in Tables I and II must be corrected for viscous effects and appendage lifting effects. The program allows the user to input additional viscous damping in surge and/or roll.

$$A_{11} = \int a_{11} dx$$

$$B_{11} = \int b_{11} dx$$

$$A_{13} = \int a_{13} dx$$

$$B_{13} = \int b_{13} dx$$

$$A_{31} = A_{13}$$

$$B_{31} = B_{13}$$

$$A_{15} = -\int x a_{13} dx - (U_0/\omega_e^2) B_{13}$$

$$B_{15} = -\int x b_{13} dx + U_0 A_{13}$$

$$A_{51} = -\int x a_{13} dx + (U_0/\omega_e^2) B_{31}$$

$$B_{51} = -\int x b_{31} dx - U_0 A_{13}$$

$$A_{33} = \int a_{33} dx$$

$$B_{33} = \int b_{33} dx$$

$$A_{35} = -\int x a_{33} dx - (U_0/\omega_e^2) B_{33}$$

$$B_{35} = -\int x b_{33} dx + U_0 A_{33}$$

$$A_{53} = -\int x a_{33} dx + (U_0/\omega_e^2) B_{33}$$

$$B_{53} = -\int x b_{33} dx + U_0 A_{33}$$

$$A_{55} = \int x^2 a_{33} dx + (U_0^2/\omega_e^2) A_{33}$$

$$B_{55} = \int x^2 b_{33} dx + (U_0^2/\omega_e^2) B_{33}$$

$$C_{33} = \rho g \int B(x) dx$$

$$C_{35} = C_{53}$$

$$= -\rho g \int x B(x) dx$$

$$C_{55} = \rho g \nabla GM_L + LCF^2 C_{33}$$

$$\equiv \rho g \int x^2 B(x) dx$$

Table 1. Vertical Mode Coefficients

$A_{22} = \int a_{22}dx$	$B_{22} = \int b_{22}dx$
$A_{24} = A_{42}$ $= \int a_{24}dx$	$B_{24} = B_{42}$ $= \int b_{24}d\xi$
$A_{26} = \int xa_{22}dx + (U_o/\omega_e^2)B_{22}$	$B_{26} = \int xb_{22}dx - U_oA_{22}$
$A_{44} = \int a_{44}dx$	$B_{44} = B_e$
$A_{46} = \int xa_{24}dx + (U_o/\omega_e^2)B_{24}$	$B_{46} = \int xb_{24}dx - U_oA_{24}$
$A_{62} = \int xa_{22}dx - (U_o/\omega_e^2)B_{22}$	$B_{62} = \int xb_{22}dx + U_oA_{22}$
$A_{64} = \int xa_{24}dx - (U_o/\omega_e^2)B_{24}$	$B_{64} = \int xb_{24}dx + U_oA_{24}$
$A_{66} = \int x^2a_{22}dx + (U_o^2/\omega_e^2)A_{22}$	$B_{66} = \int x^2b_{22}dx + (U_o^2/\omega_e^2)B_{22}$
$C_{44} = \rho g \nabla GM_T$	
All integrals are over the ship length.	

Table 2. Horizontal Mode Coefficients

$$F_j = F_j^I + F_j^D$$

$F_j^D$  = Diffraction Exciting Force

$$F_j^I = \int_L e^{-ikx \cos\beta} f_j(x) dx \quad j = 1,2,3,4$$

$$F_5^I = -\int_L e^{-ikx \cos\beta} x f_3(x) dx$$

$$F_6^I = \int_L e^{-ikx \cos\beta} x f_2(x) dx$$

$f_j(x)$  = sectional Froude-Krylov exciting force for infinite depth

$$= \rho g a \int_{C_x} N_j e^{-iky \sin\beta} e^{kz} dl \quad j = 1,2,3,4$$

$$F_j^D = \int_L e^{-ikx \cos\beta} h_j(x) dx \quad j = 1,2,3,4$$

$$F_5^D = -\int_L e^{-ikx \cos\beta} (x + (U_0/\omega_0)) h_3(x) dx$$

$$F_6^D = \int_L e^{-ikx \cos\beta} (x + (U_0/\omega_0)) h_2(x) dx$$

$h_j(x)$  = sectional diffraction exciting force for infinite depth

$$= \rho a \omega_0 \int_{C_x} (iN_3 + N_1 \cos\beta + N_2 \sin\beta) e^{-iky \sin\beta} e^{kz} \psi_j(y,z) dl$$

$$j = 1,2,3,4$$

Table 3. Summary of Exciting Forces

### C. BUILDING THE SLICE MODEL

The computer program that was used to calculate the hydrodynamic data was SHIPMO.BM written by Robert F. Beck and Armin W. Troesch. This program has been designed to calculate many different aspects of ship motion given a variety of inputs. The first step in using this program is to accurately model the ship's underwater hull for use in the program. The method used to model the underwater portion of the hull must be very specific and follow the guidelines that are set up in the program. The descriptive hull points must be inputted in the manner shown below in Figure 3.

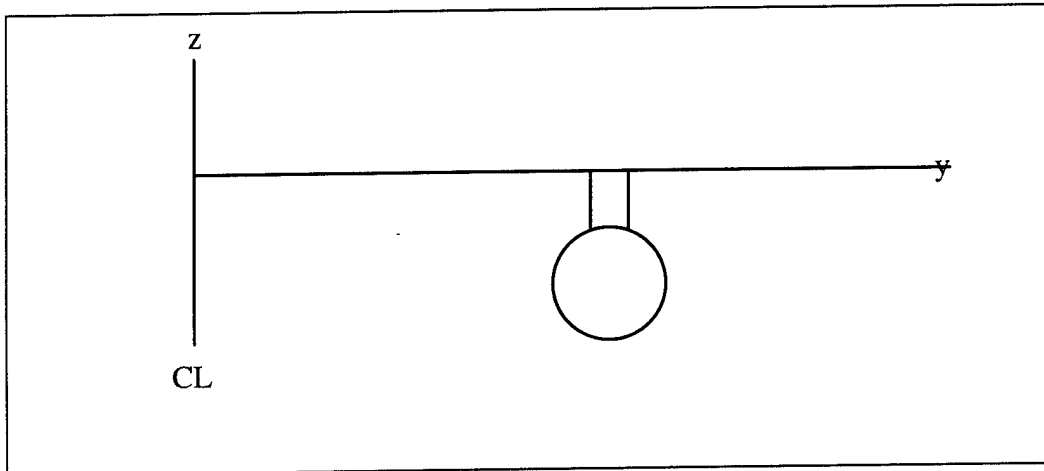

Figure 3. Input of SLICE Hull

The program assumes that the ship is symmetric about the centerline so only half the ship's dimensional data is inputted into the program. The points are inputted into a data file in a (y,z) format that describes the hull shape. The y-axis is the waterline of the ship and this offset distance is started at point number 1 and continued around the hull. The z-axis is a negative distance below the waterline and this distance is included in the y,z coordinates of each point. The program inputs this data file for use in the calculations. A maximum of 15 points are allowed at each station. The ship was divided into 19 stations at frames that best described the underwater hull and the coordinates of each station were inputted into the program. These stations do not have to be equidistant

from each other. A sample of the input file used has been included in the Appendix. The following set of Figures show each of the stations as they were inputted into the input file.

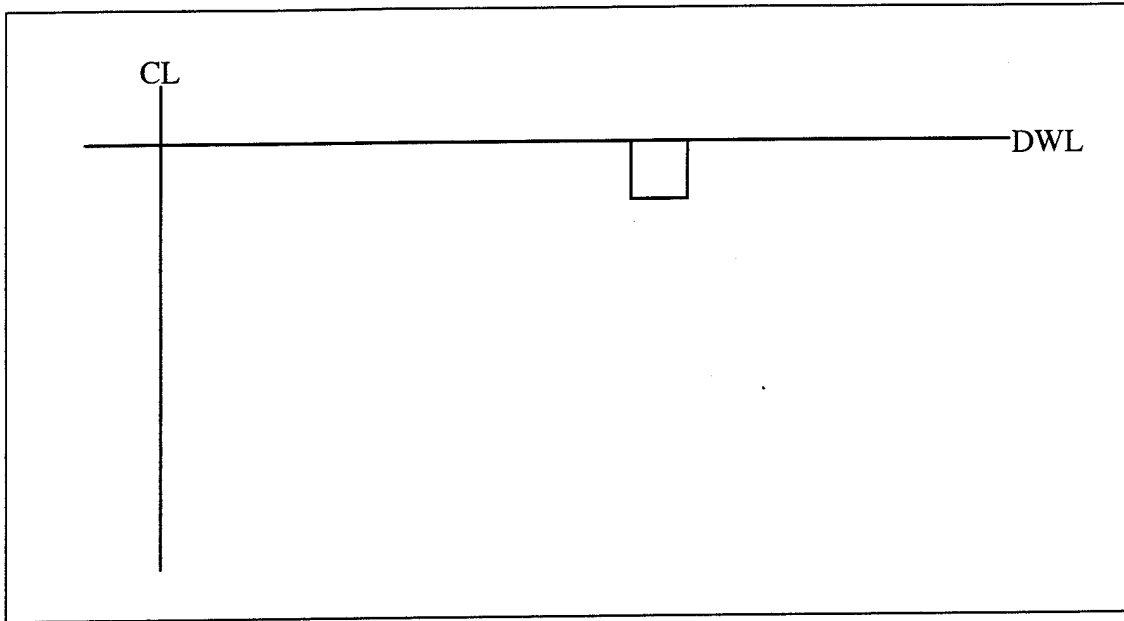

Figure 4. Station 1 (Frame 3)

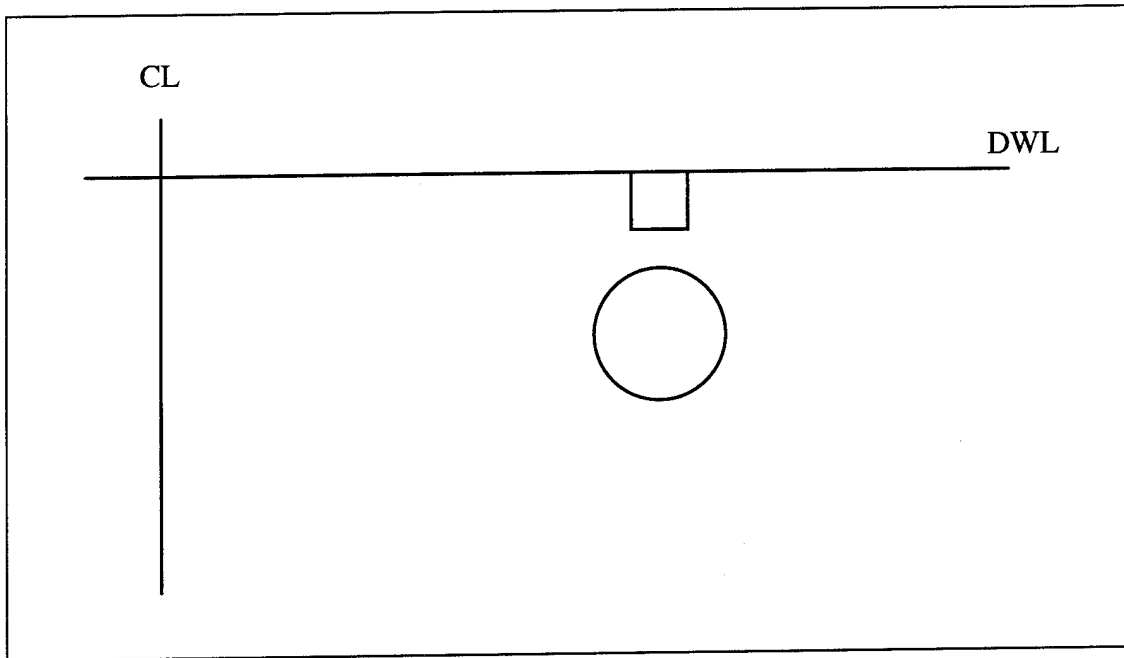

Figure 5. Station 2 (Frame 5)

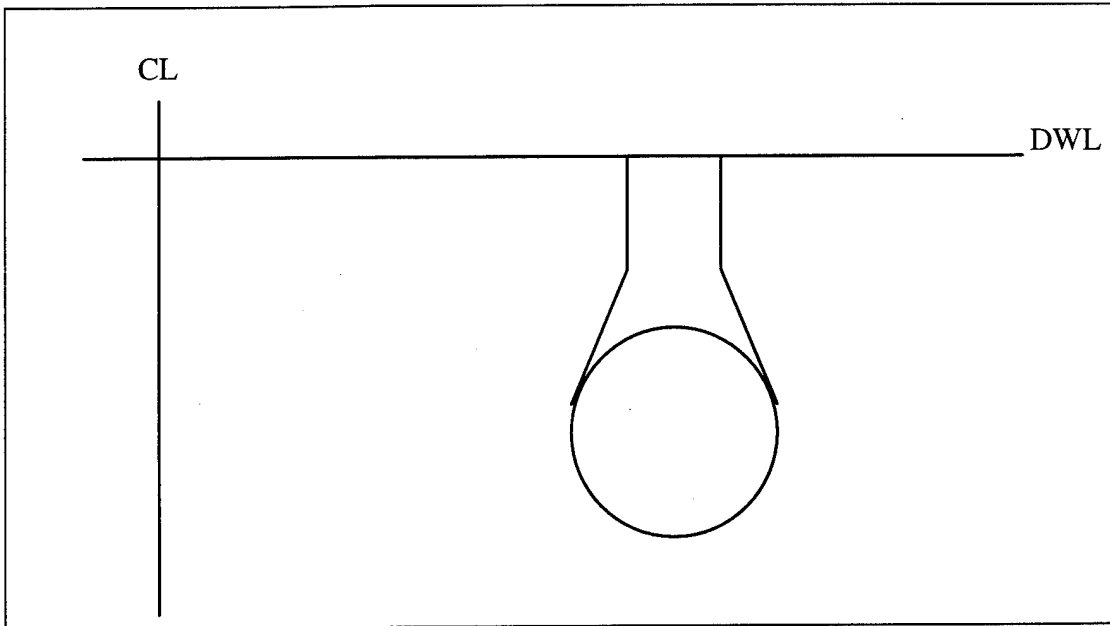

Figure 6. Station 3 & 4 (Frame 10 & 15)

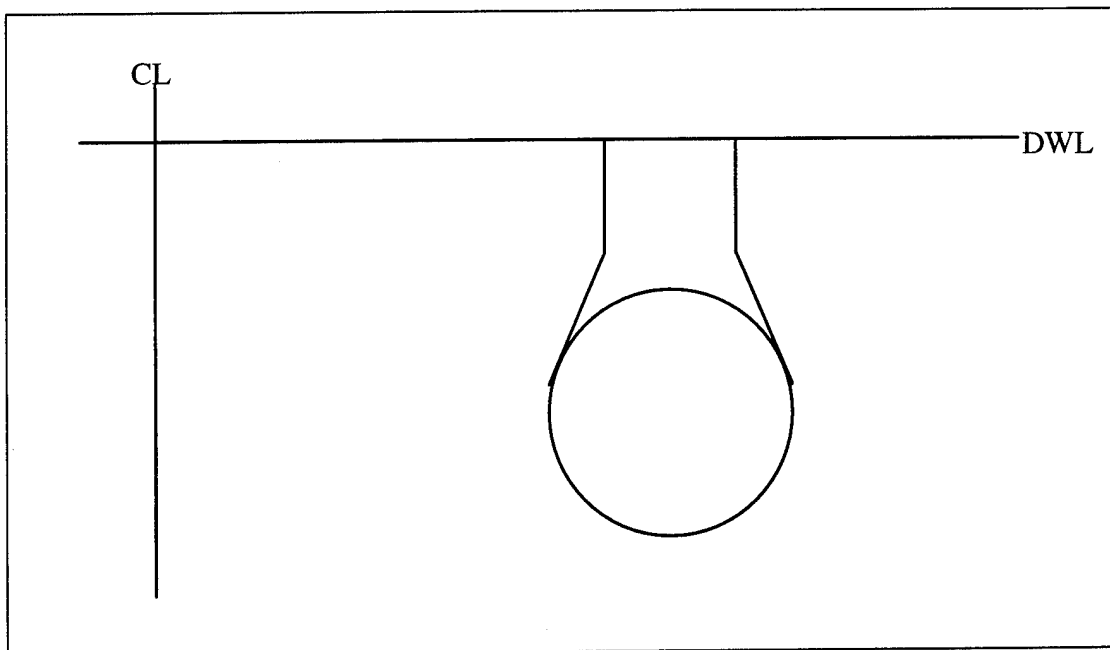

Figure 7. Station 5 (Frame 20)

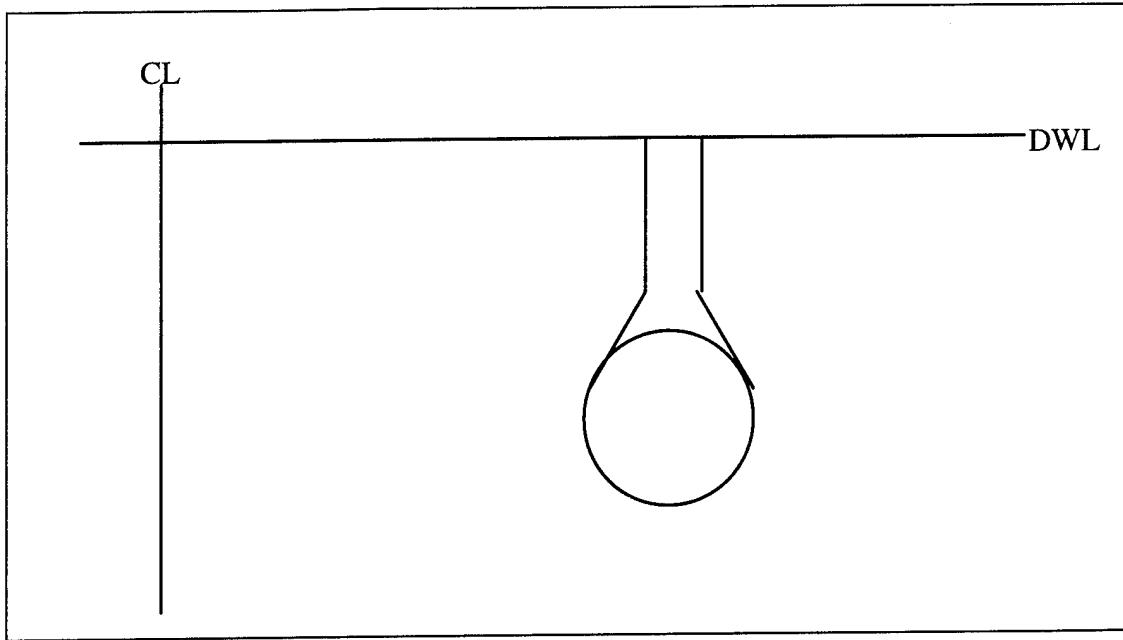

Figure 8. Station 6 (Frame 25)

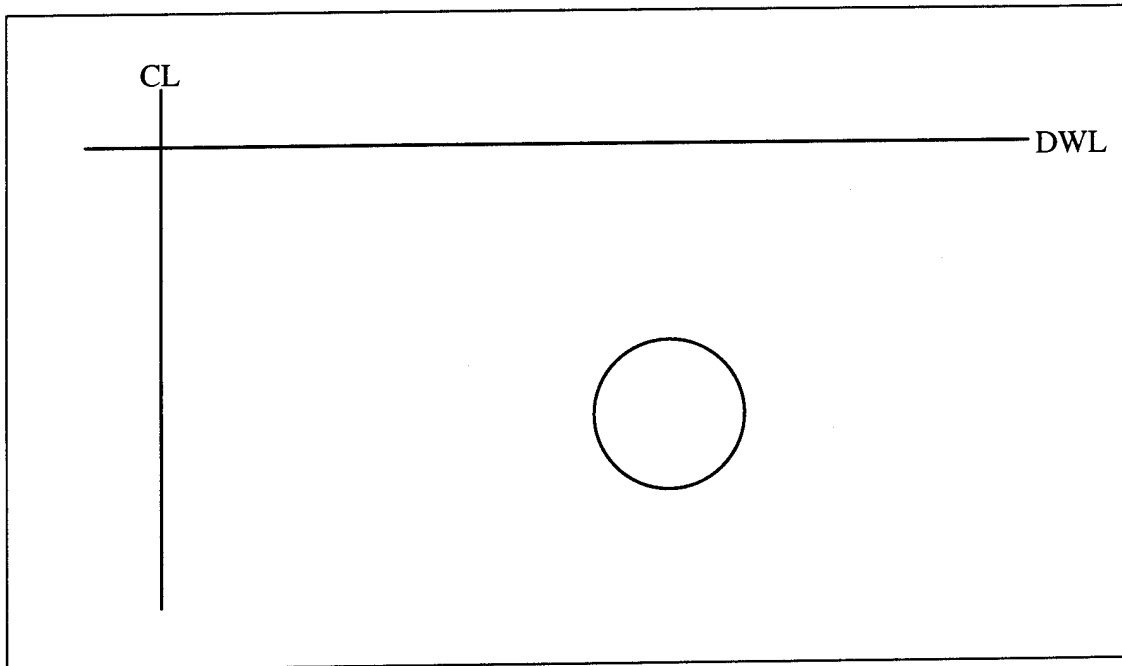

Figure 9. Station 7 (Frame 29)

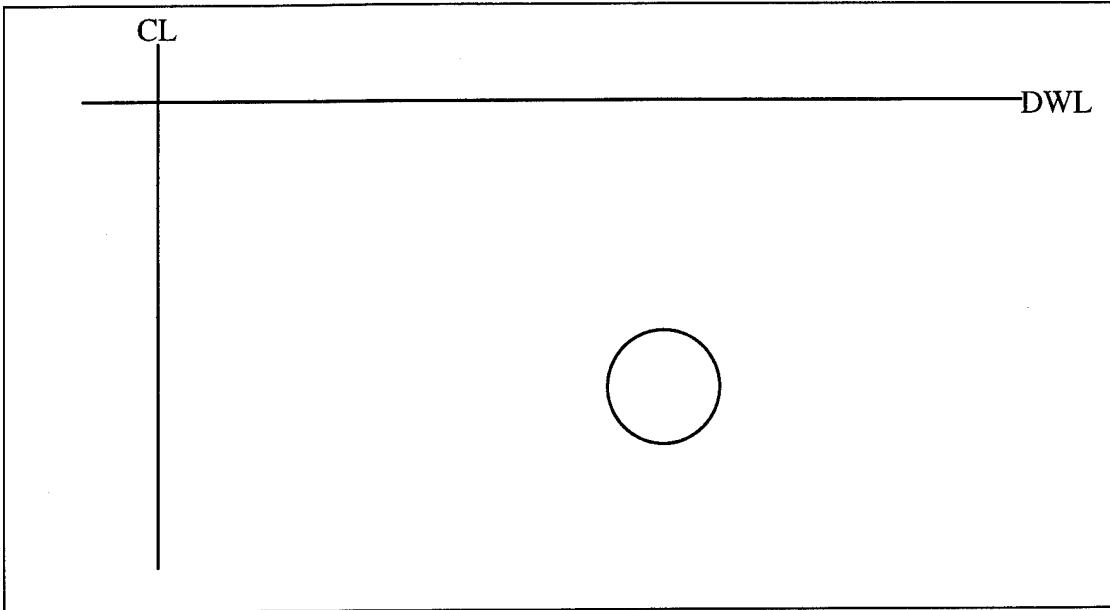

Figure 10. Station 8 (Frame 32)

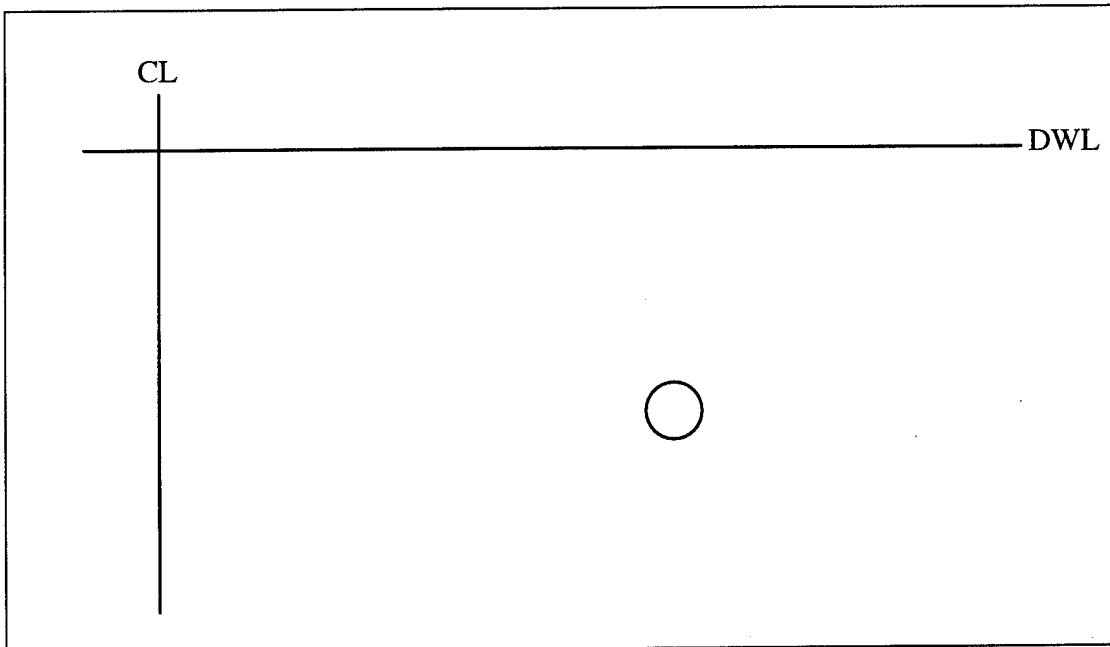

Figure 11. Station 9 (Frame 36)

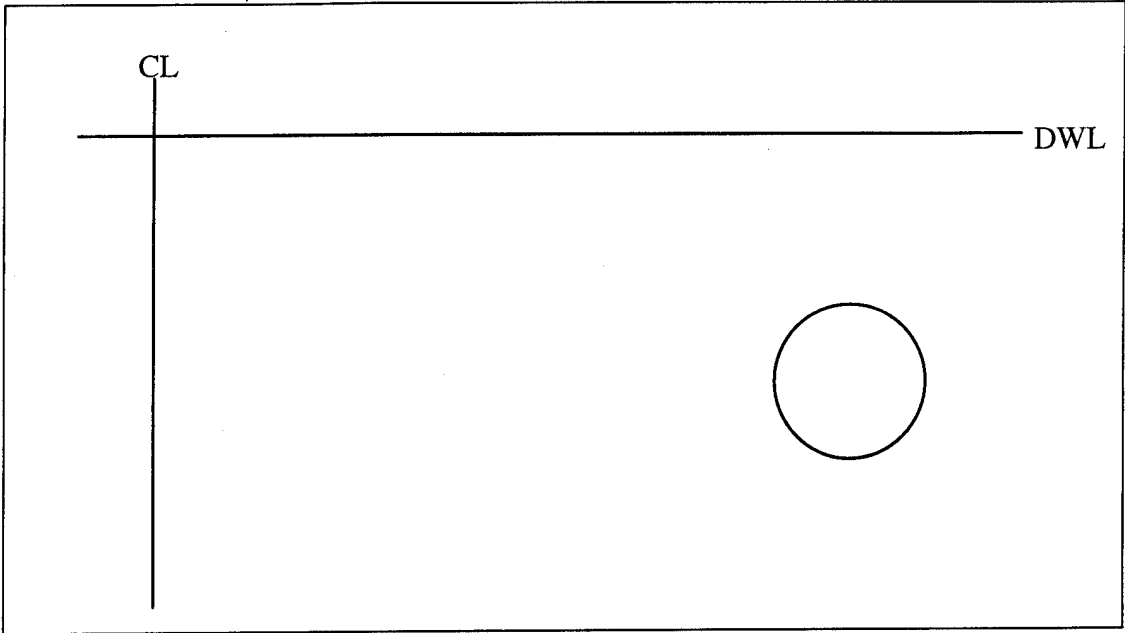

Figure 12. Station 11 (Frame 55)

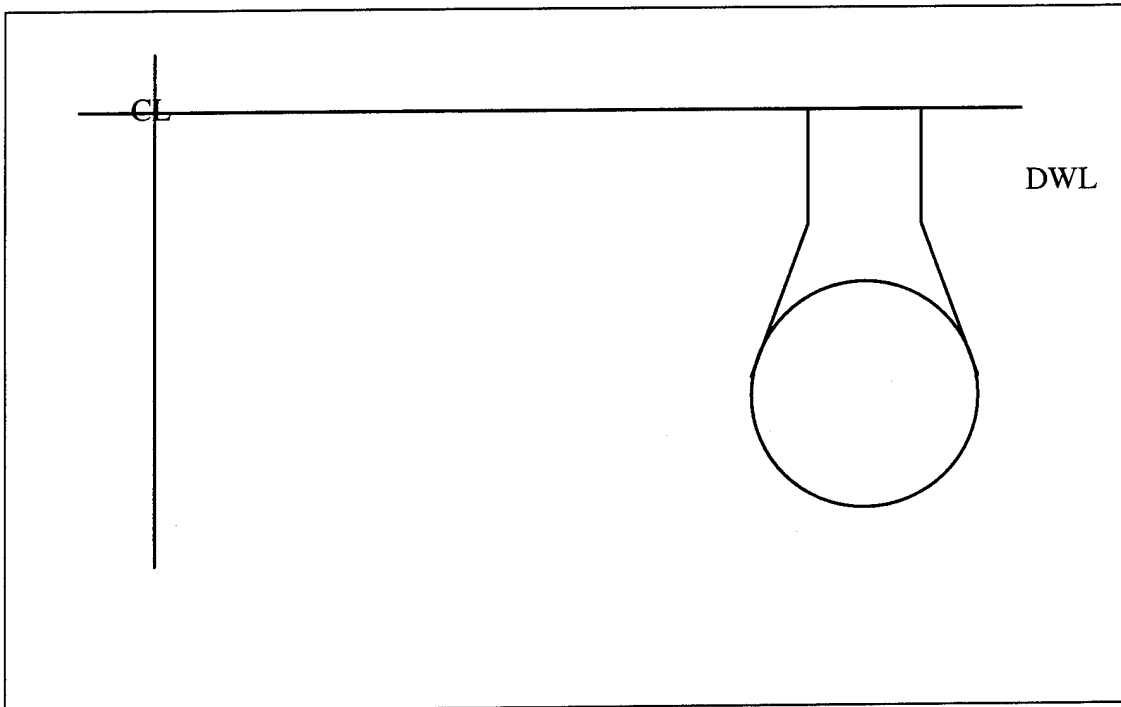

Figure 13. Station 12 (Frame 57)

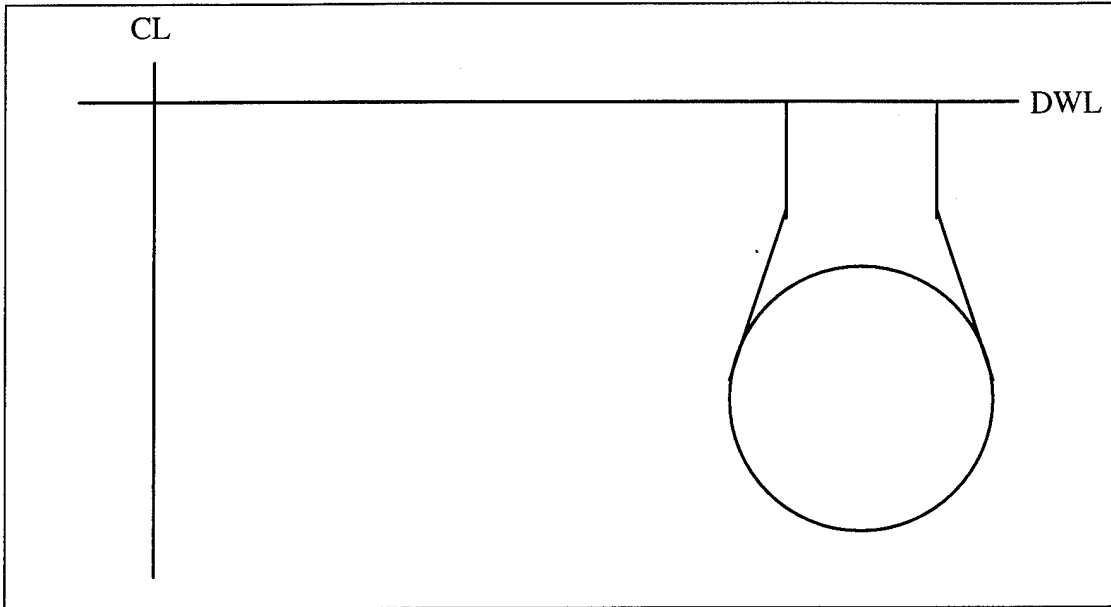

Figure 14. Station 13 & 14 (Frame 62 & 67)

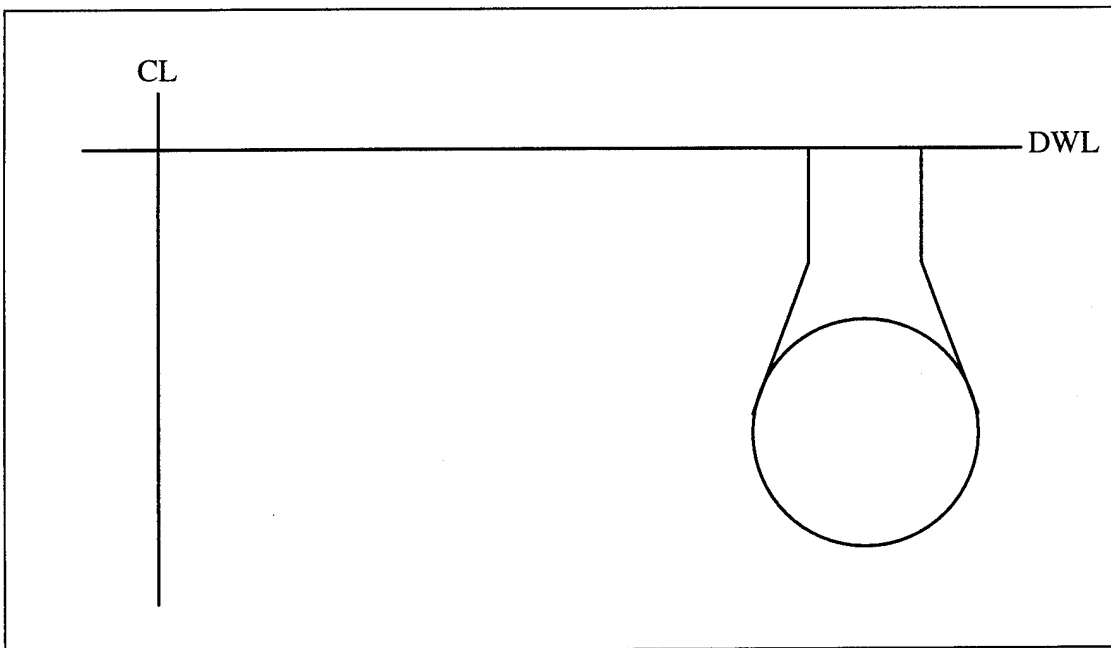

Figure 15. Station 15 (Frame 71)

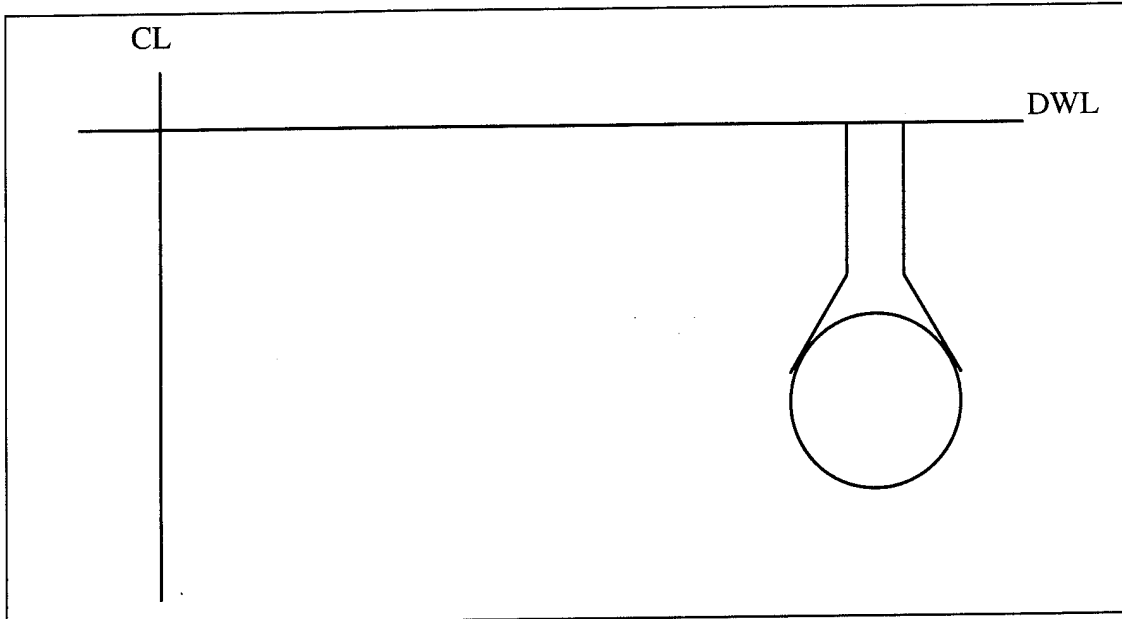

Figure 16. Station 16 (Frame 75)

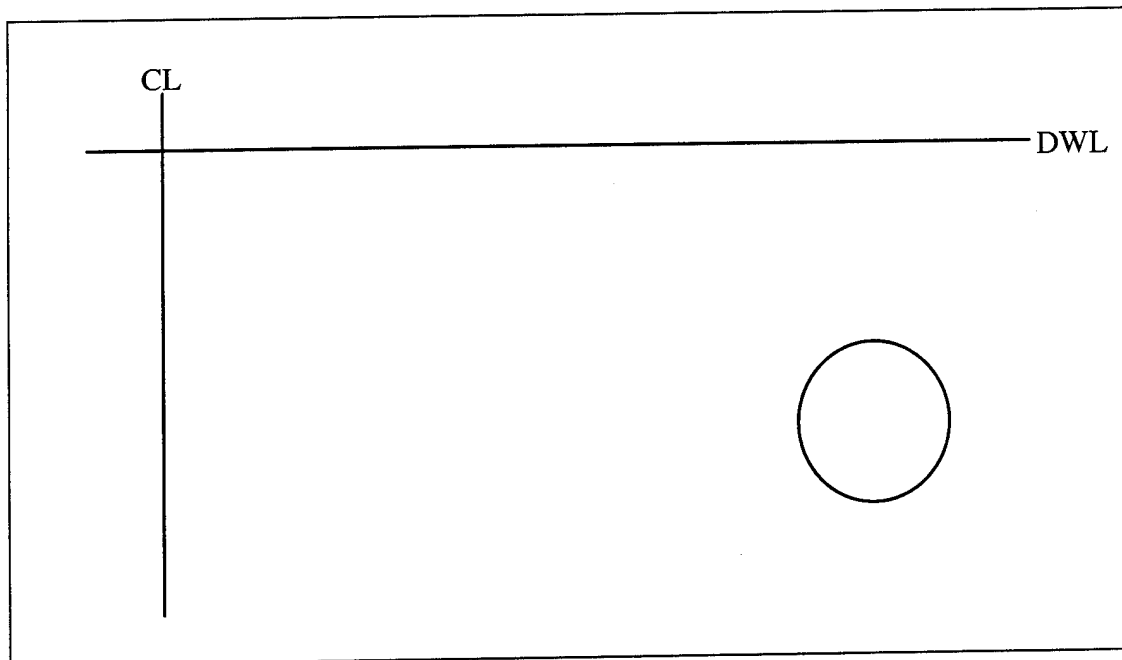

Figure 17. Station 17 (Frame 79)

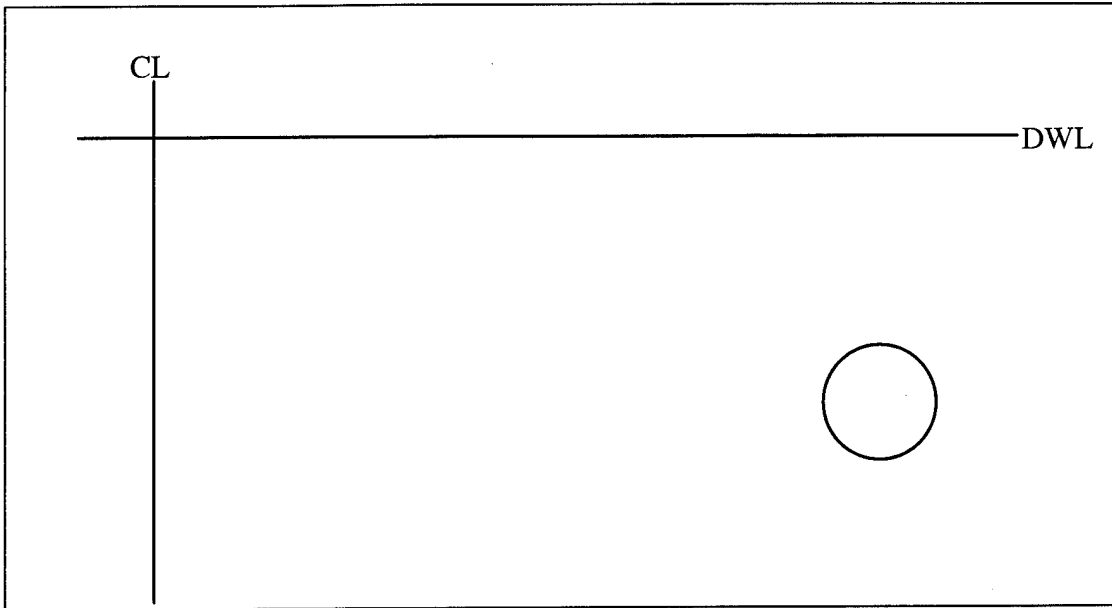

Figure 18. Station 18 (Frame 82)

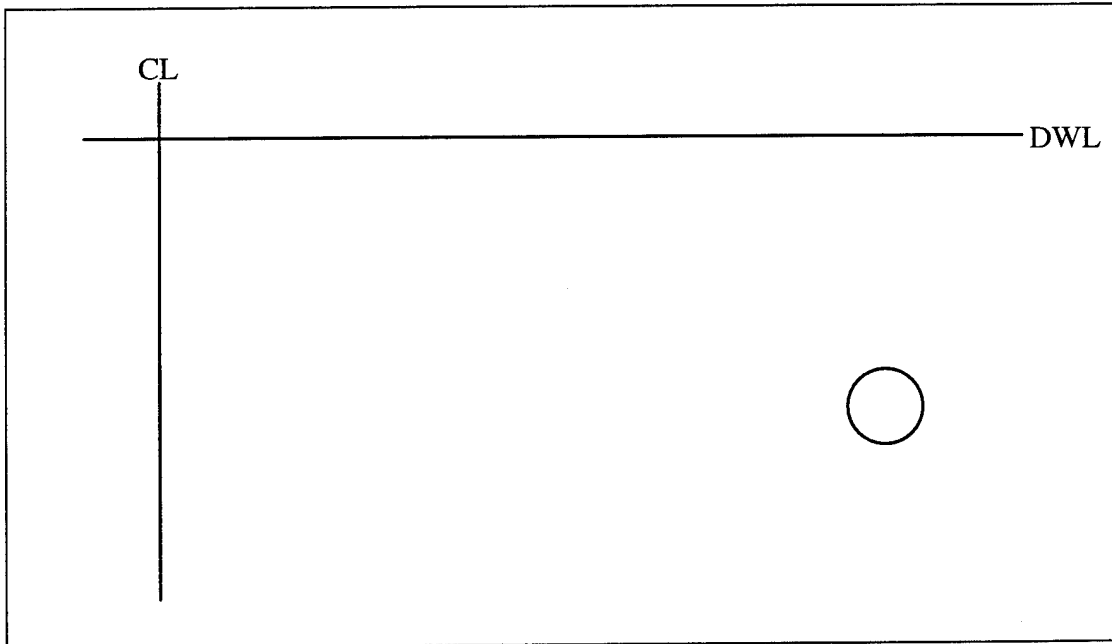

Figure 19. Station 19 (Frame 86)



### III. RESULTS AND DISCUSSION

#### A. GENERAL

The ability to predict the trends and general magnitudes of a ship's motion is a very valuable tool in ship design, especially when there is very little experimental data available. Currently there has been no theoretical modeling of the SLICE for the purpose of studying the hydrodynamic properties of this hull form. There is a reasonable amount of data available for the SWATH ship and this information can be used for comparison purposes but the two hull designs do differ and the results can not be expected to match completely. The study of this paper deals primarily with vertical plane motion only and in two-dimensional potential flow. The added mass coefficients and damping coefficients for heave motion,  $A_{33}$  and  $B_{33}$ , respectively are developed. Also the added mass coefficients and the damping coefficients for pitch motion,  $A_{55}$  and  $B_{55}$ , respectively are developed in the program. Initially these values are predicted for various wave directions and zero speed. Due to the complexity of calculating these hydrodynamic coefficients for the SLICE hull, the viscous damping effects must also be considered. The major damping contributor for the SLICE hull is no longer the wavemaking damping but the damping contributed by the viscous effects of the fluid. Even the effects of the wave generating ability of the struts of the pods since there are four struts and they are offset from each other will effect the fluid flow. If the viscous effects are neglected then the amplitude of the coefficients will react similar to that of an underdamped linear system. There will be a spiked peak in the area of resonant frequency. Unfortunately it is very difficult to calculate the viscous damping for this hull design. These results must be interpreted with these effects in mind.

## B. ADDED MASS AND DAMPING COEFFICIENTS

### 1. Sectional Added Mass and Damping Coefficients

The added mass and damping hydrodynamic coefficients for heave and pitch motion were calculated for each section of the SLICE. The results are presented in Figures 20-37, with  $a_{33}$  and  $b_{33}$  graphed versus omega. The graphs correspond with the respective stations that were presented in the previous chapter. This data is for zero speed and irregular waves. The sectional hydrodynamic coefficients calculated by this program are in nondimensional form. The nondimensional coefficients of omega,  $a_{33}$ , and  $b_{33}$  for each station are defined as:

$$\text{OMEGA} = \omega_E^2 T / g$$

$$a_{33} = a_{33} / M$$

$$b_{33} = b_{33} / M \sqrt{gL}$$

where

$\omega_e$  = frequency for the appropriate OMEGA value

M = mass of ship

L = length of ship

g = acceleration of gravity

T = time

The added mass and damping coefficients found by the SHIPMO program for the SLICE hull correspond to the same values for the SWATH hull. There are only a few discrepancies found at the first two stations. These discrepancies are some fluctuations at the lower frequencies and a couple of negative values. The station where the problems occur have very little waterplane area and thus contribute relatively nothing to the overall

hull effects. Since these results correlate relatively well to what is expected, this justifies the use of the strip theory approach to solving the equations of motion.

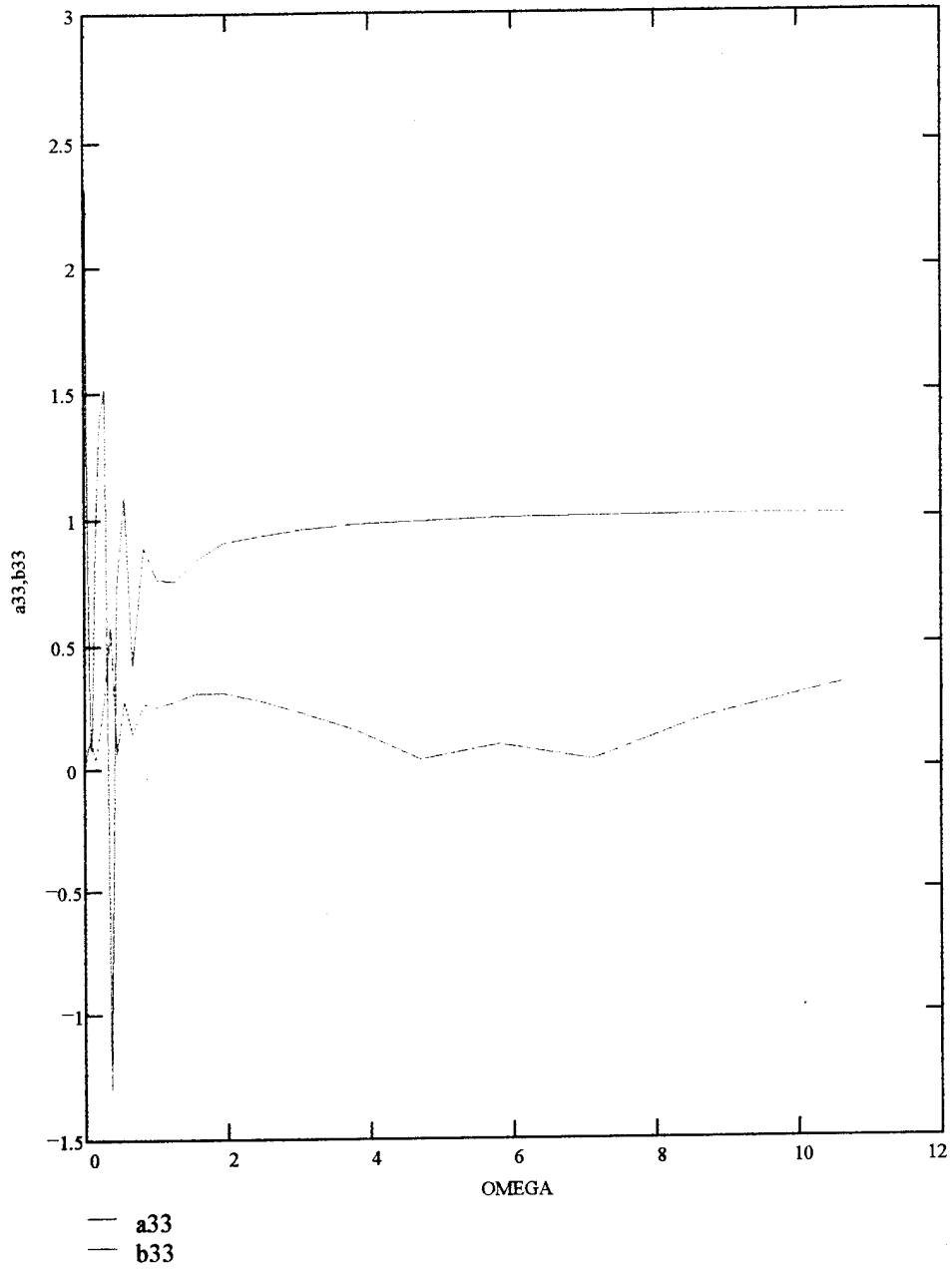

Figure 20. Station 1

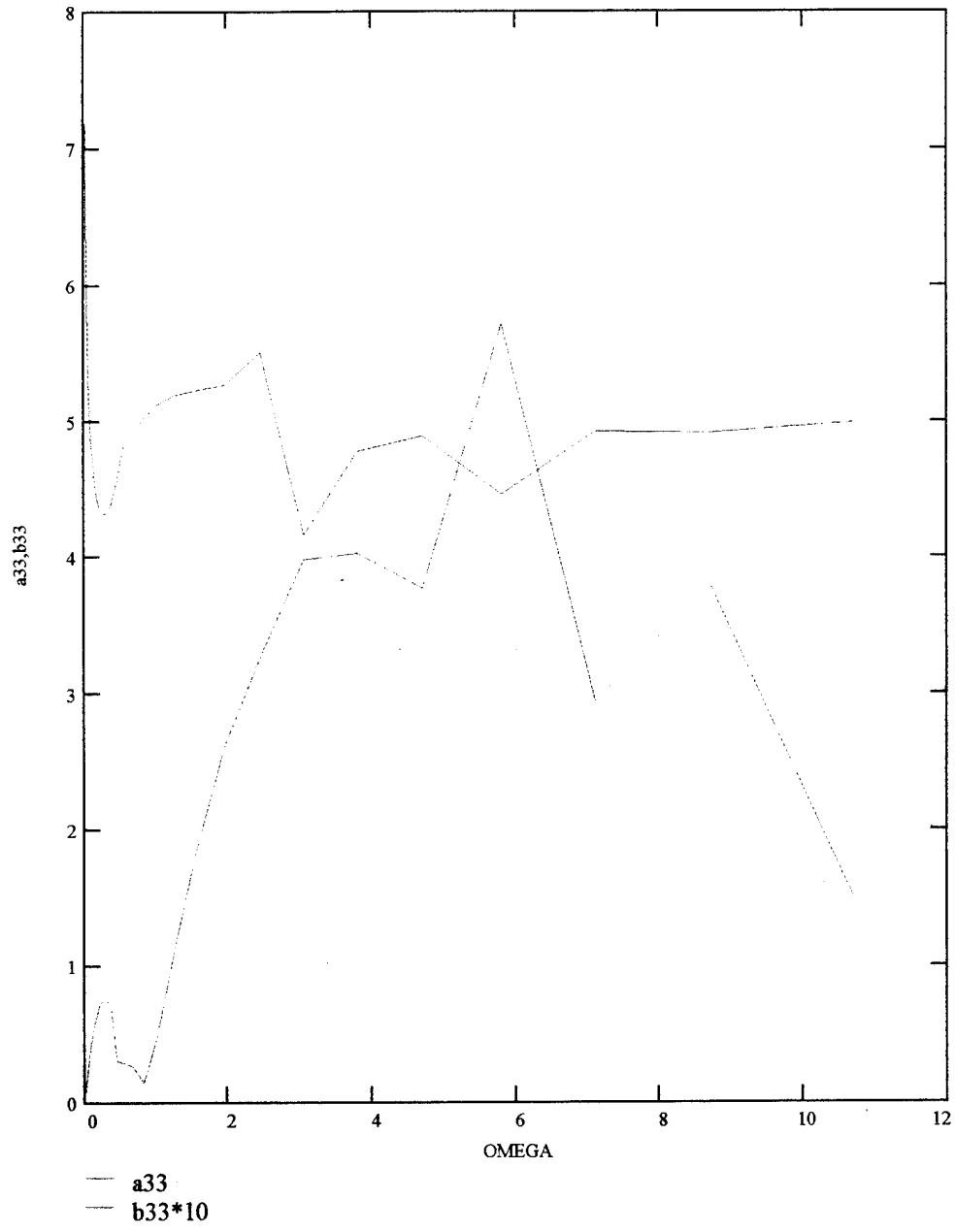

Figure 21. Station 2

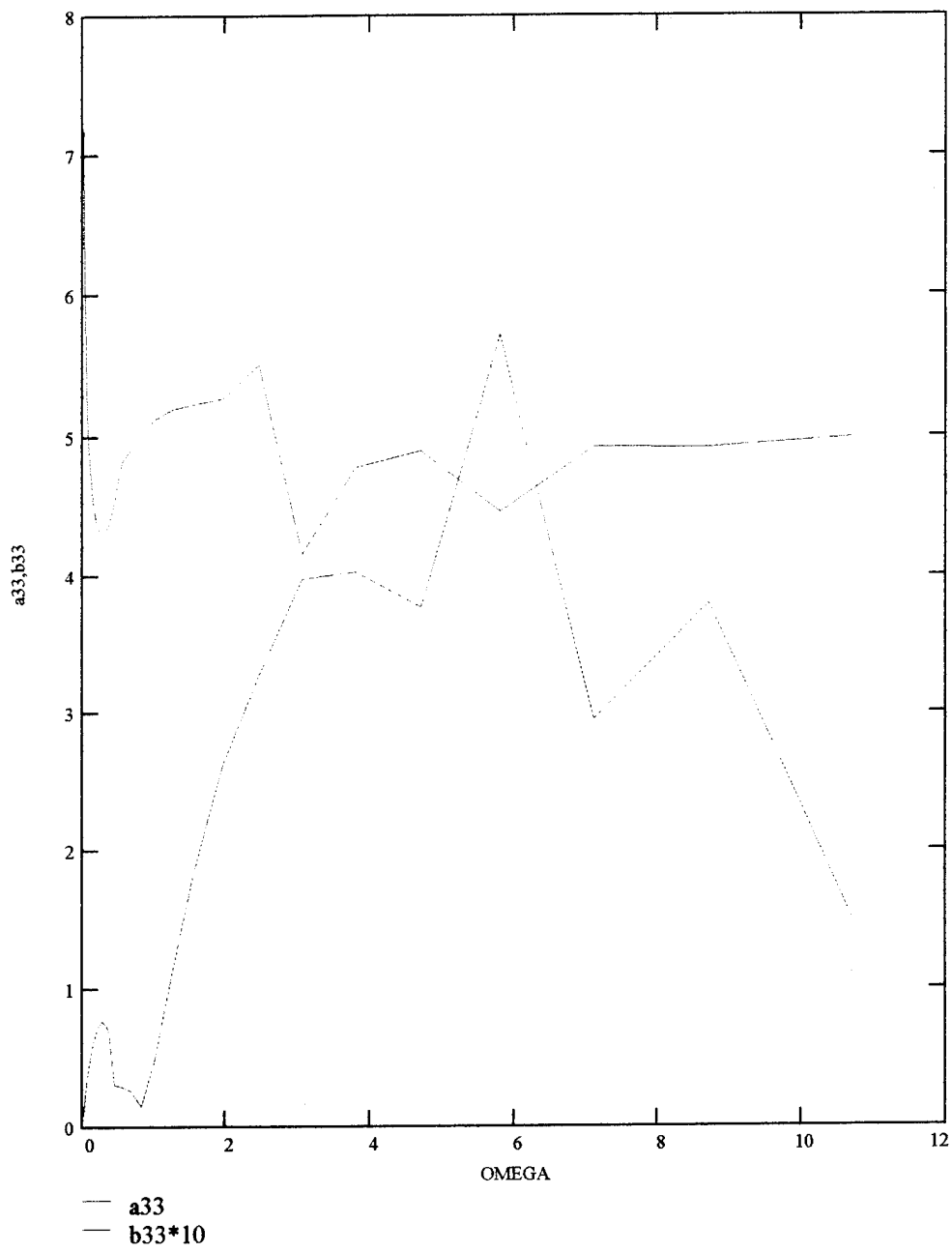

Figure 22. Station 3

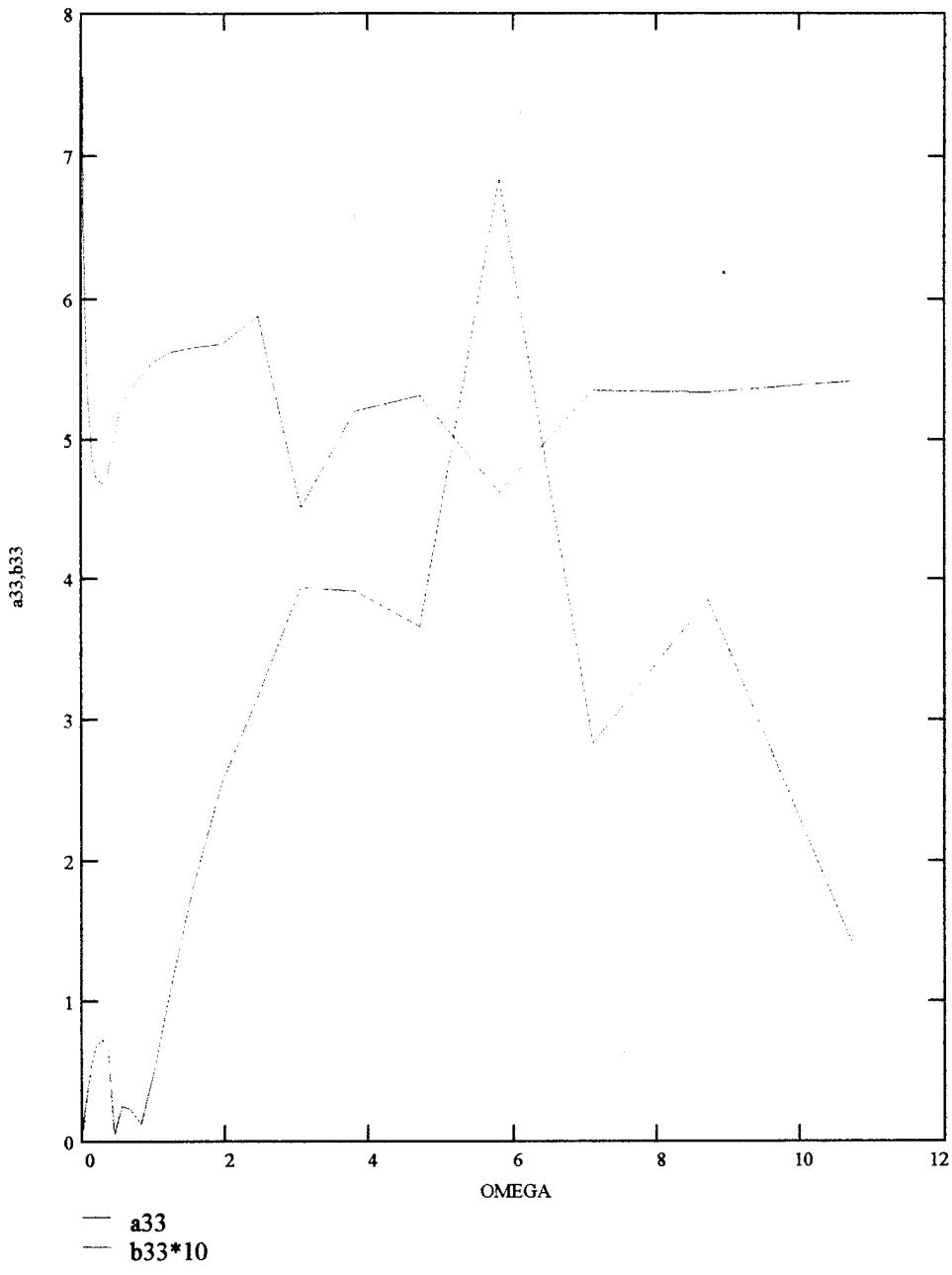

Figure 23. Station 4

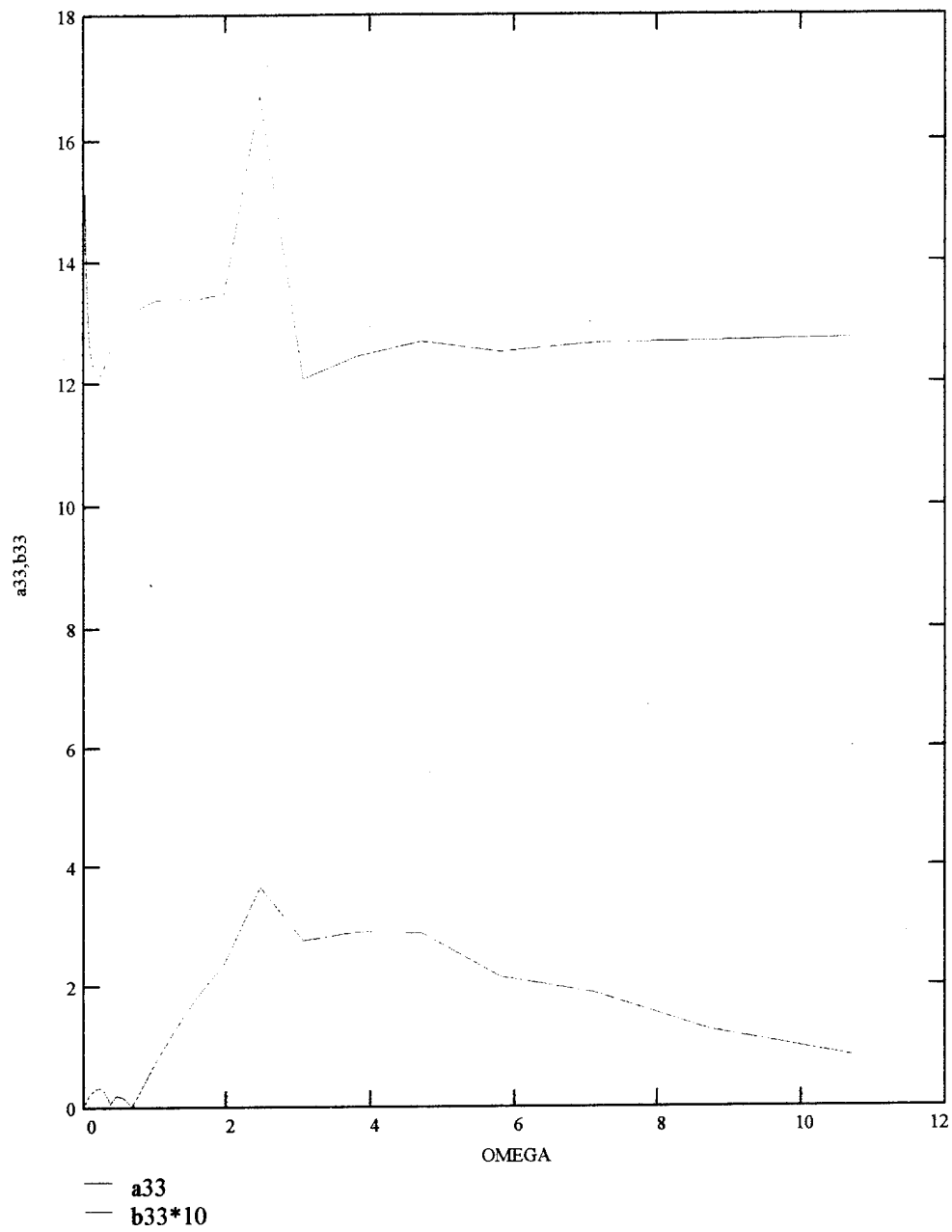

Figure 24. Station 5

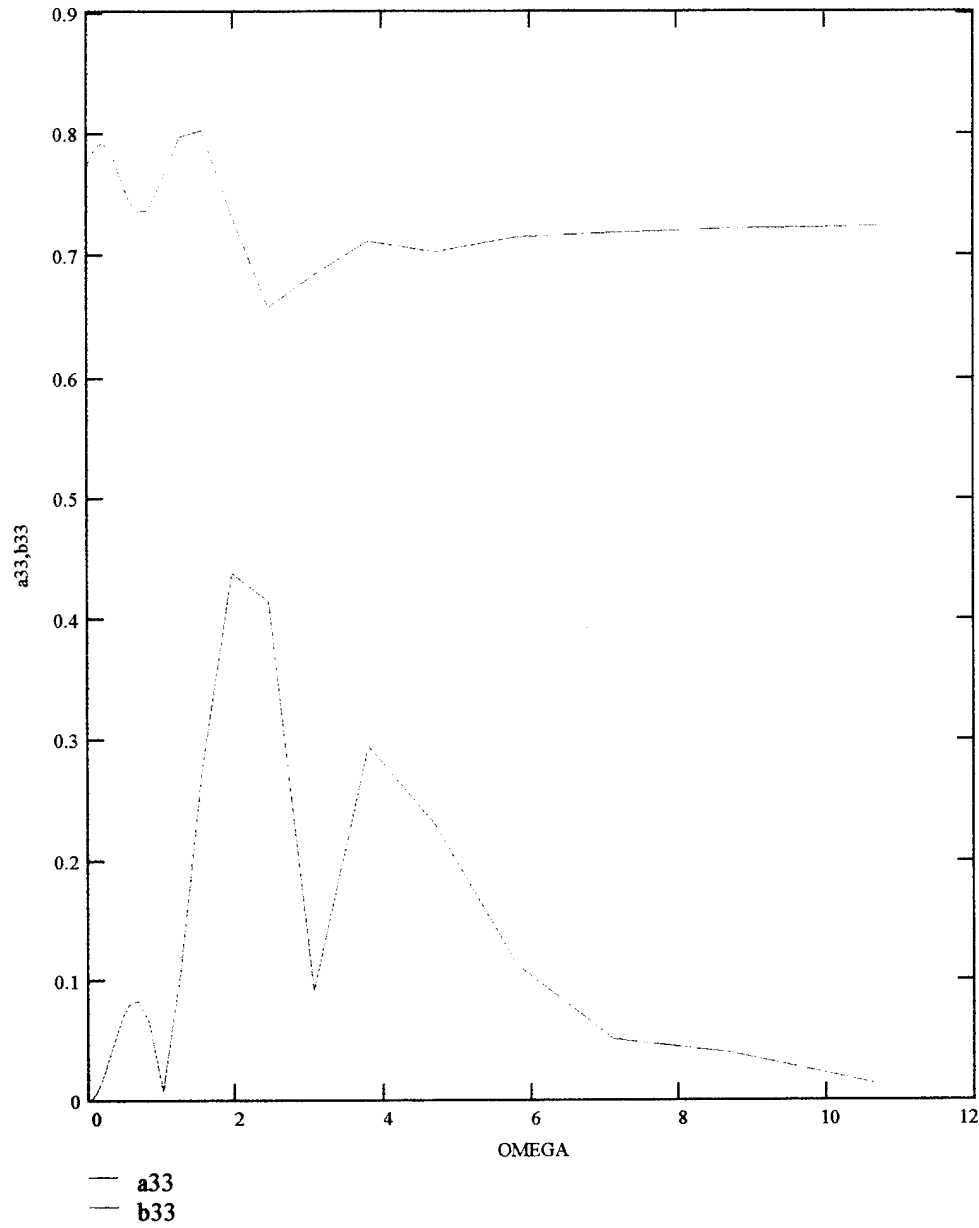

Figure 25. Station 6

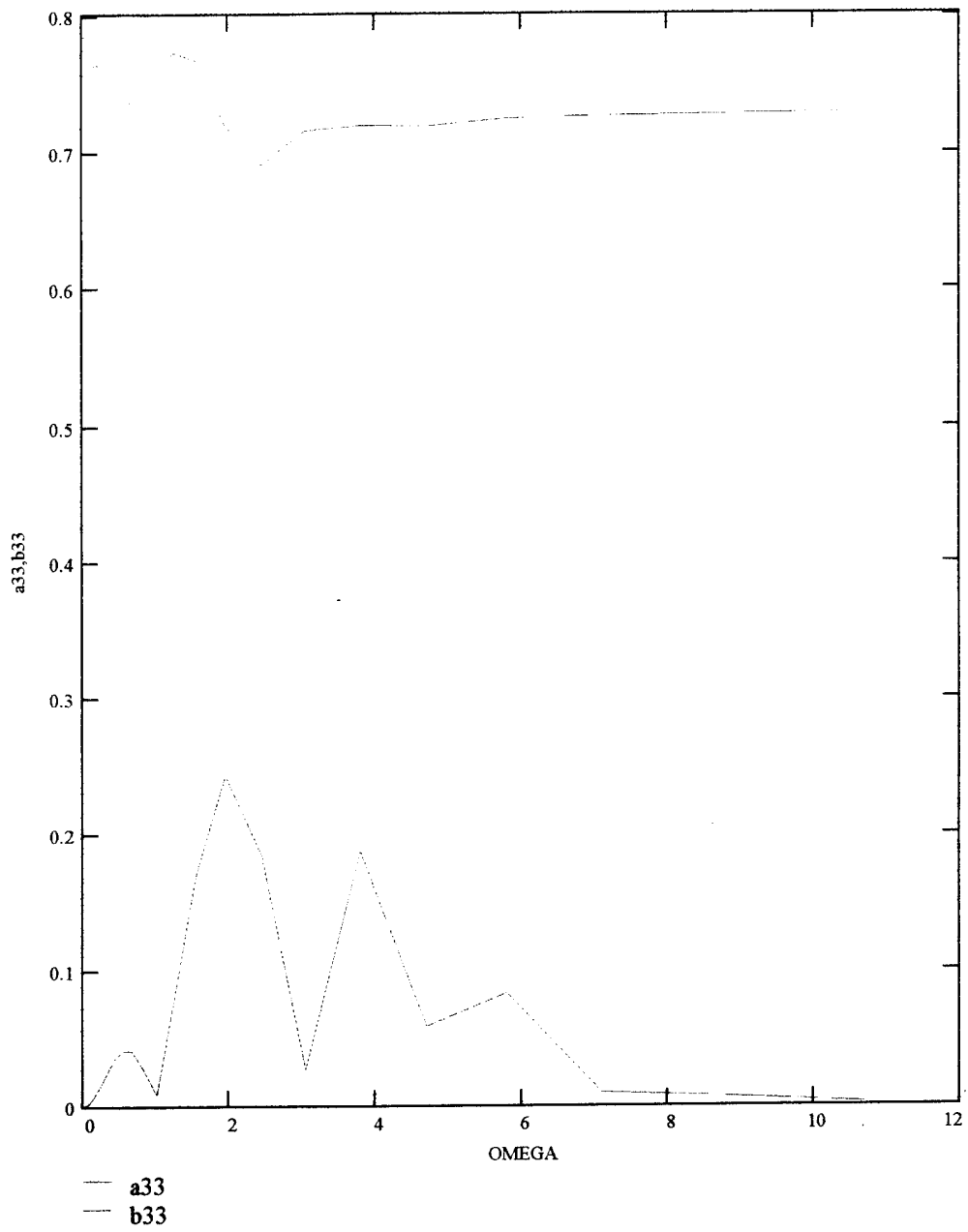

Figure 26. Station 7

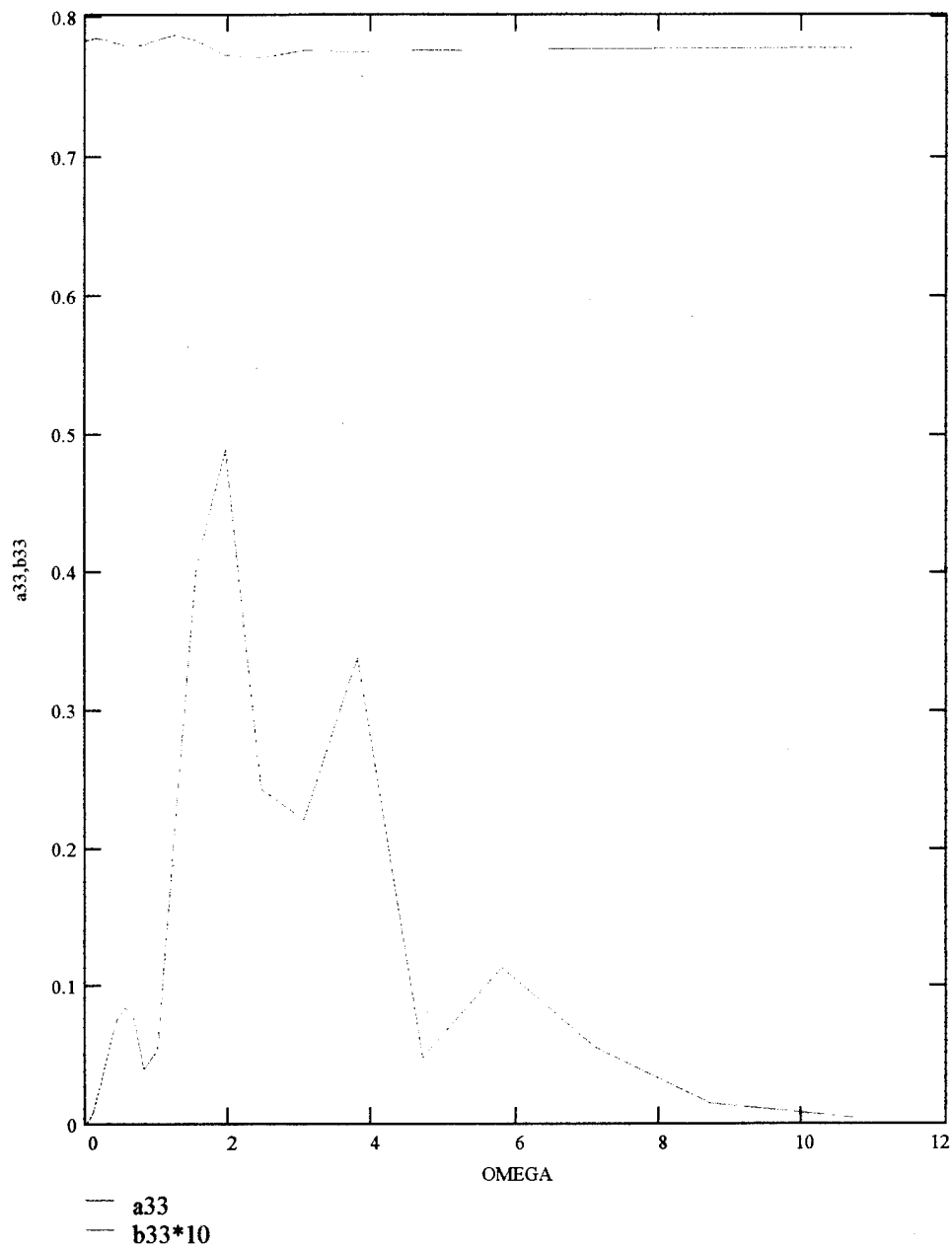

Figure 27. Station 8

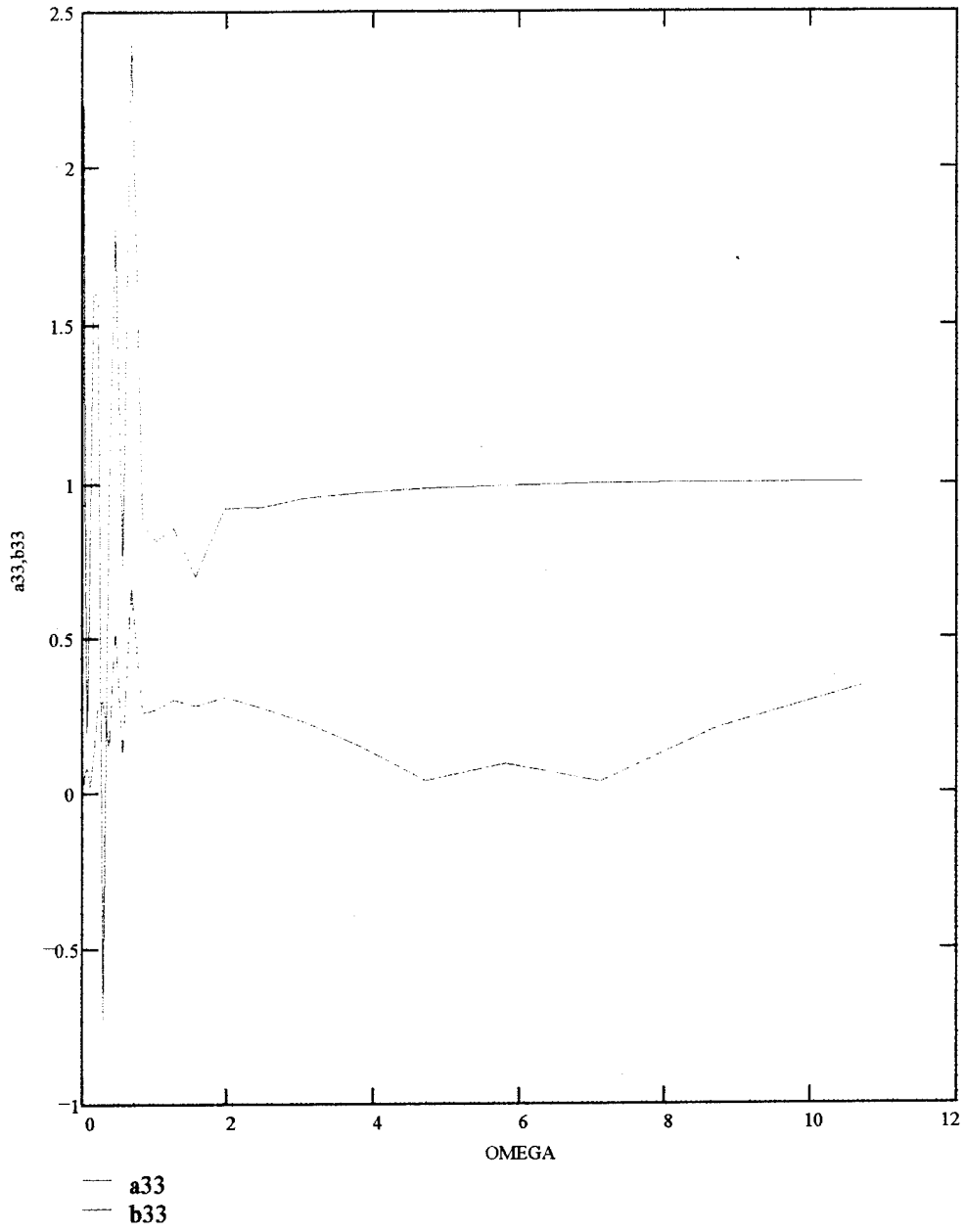

Figure 28. Station 9

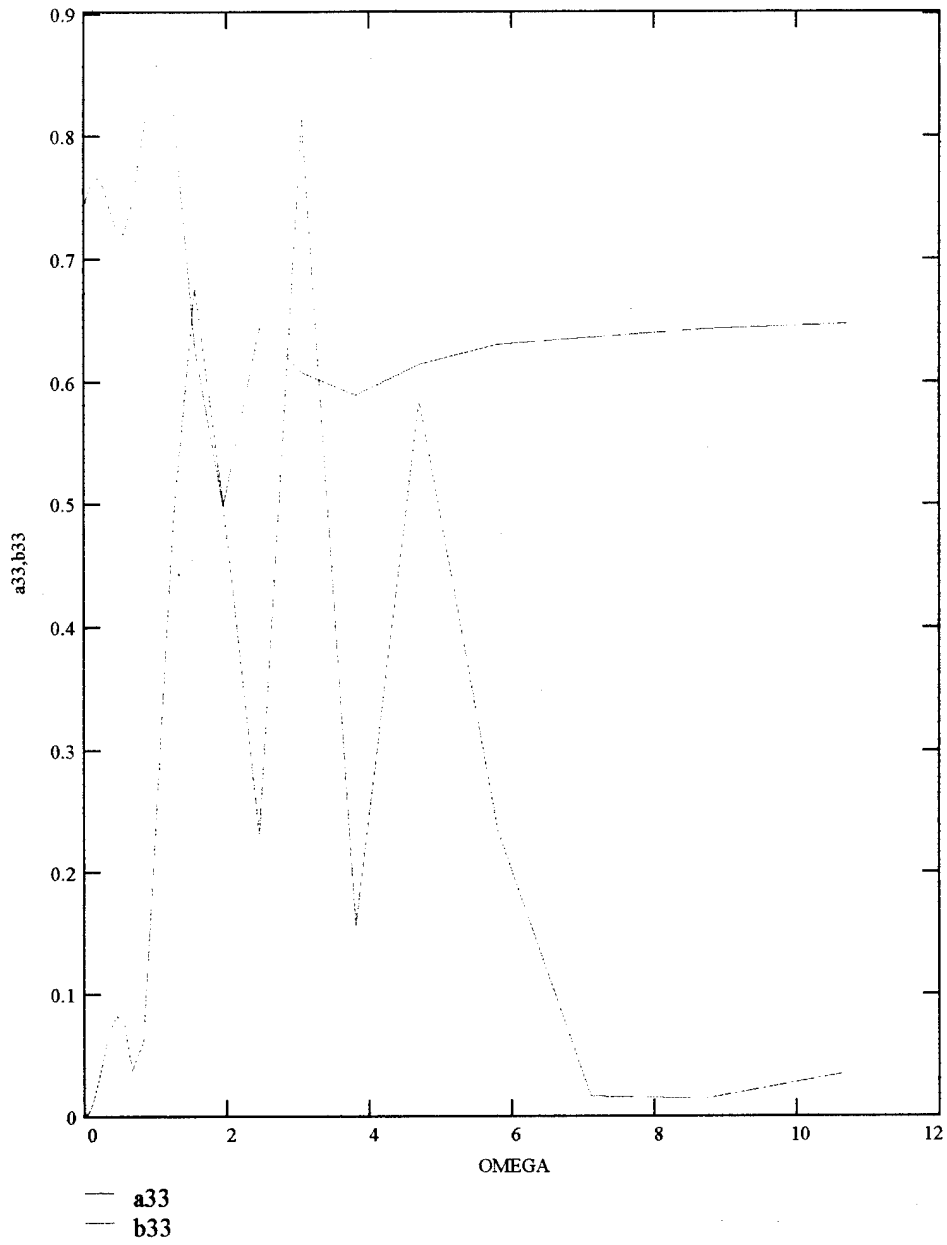

Figure 29. Station 11

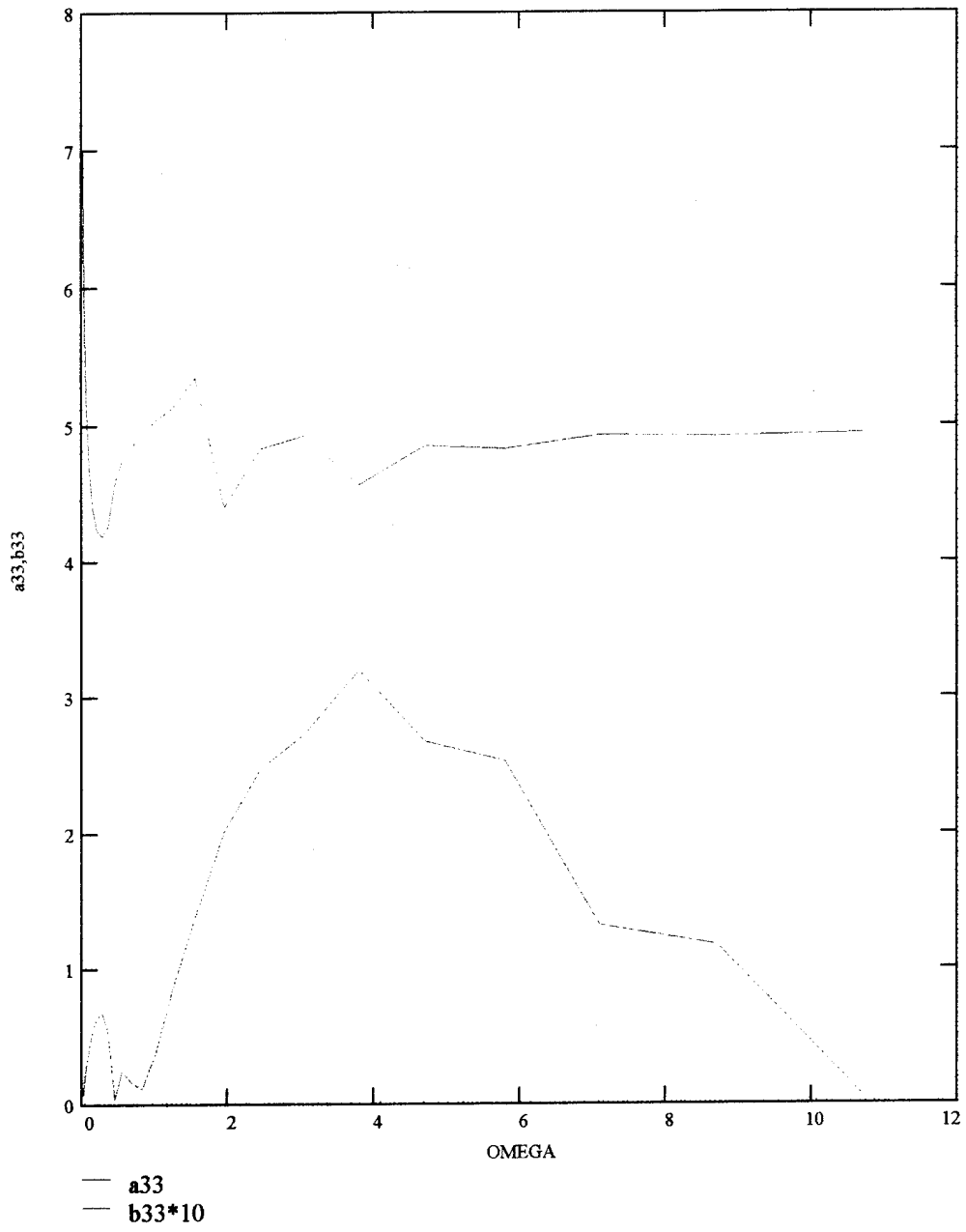

Figure 30. Station 12

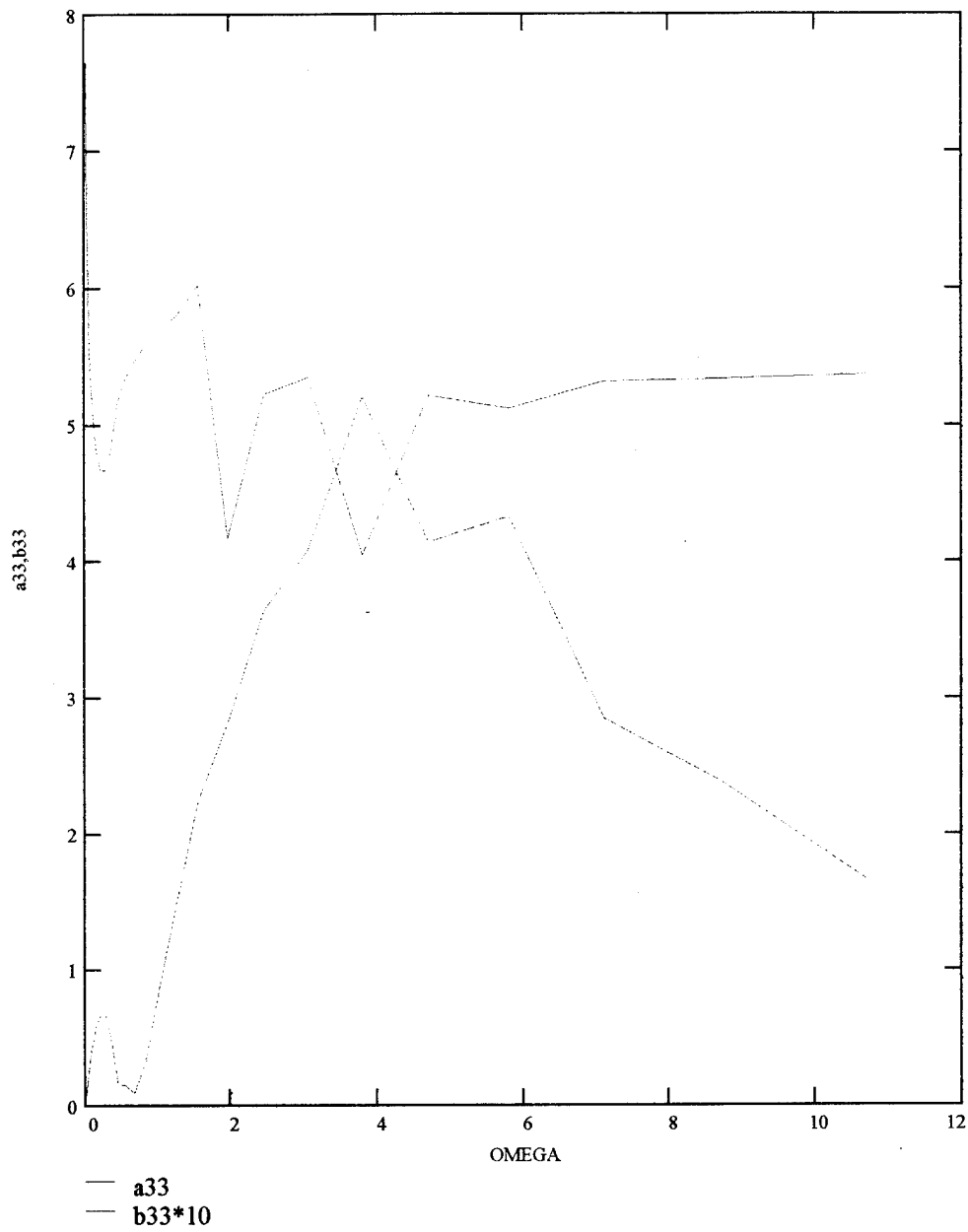

Figure 31. Station 13

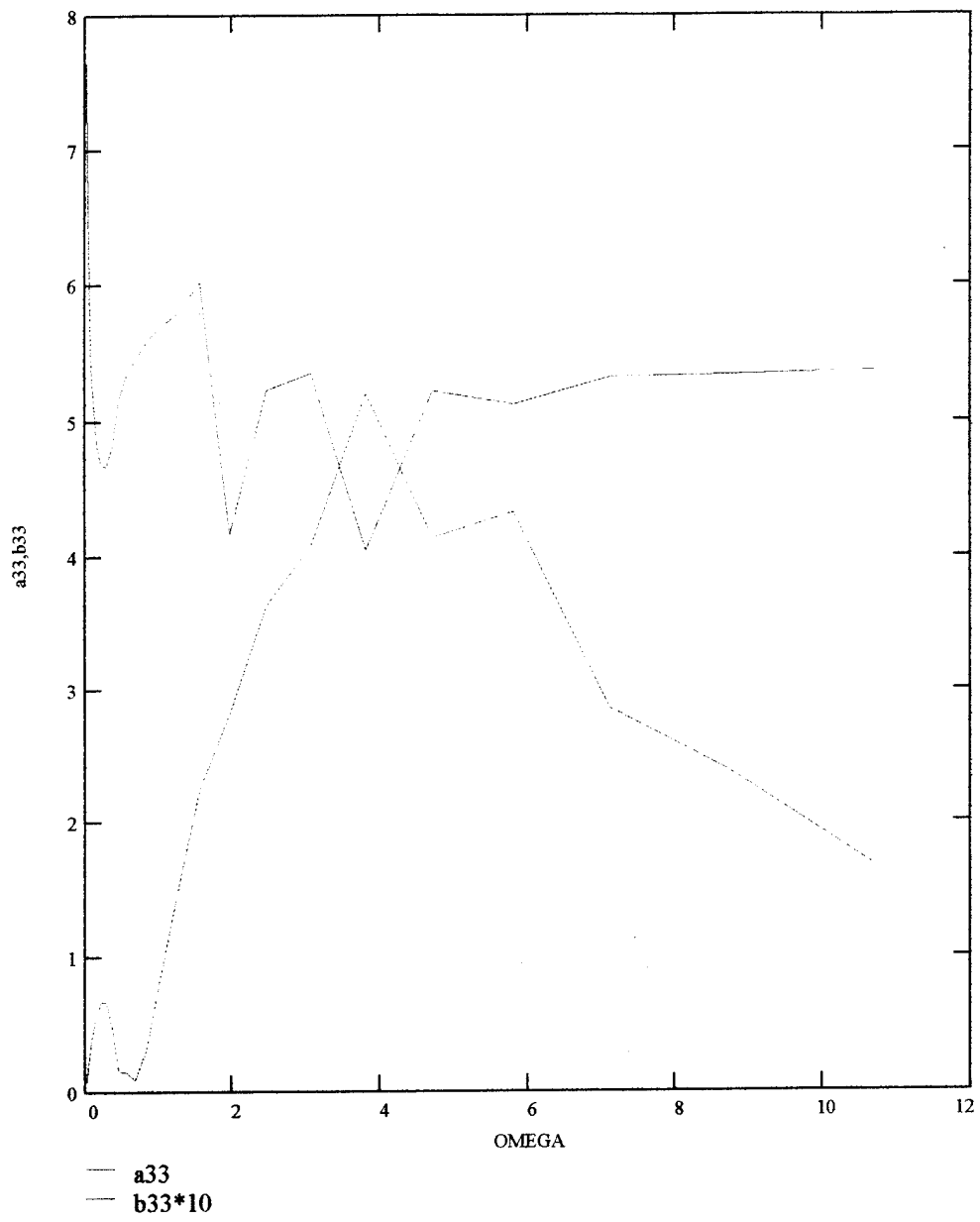

Figure 32. Station 14

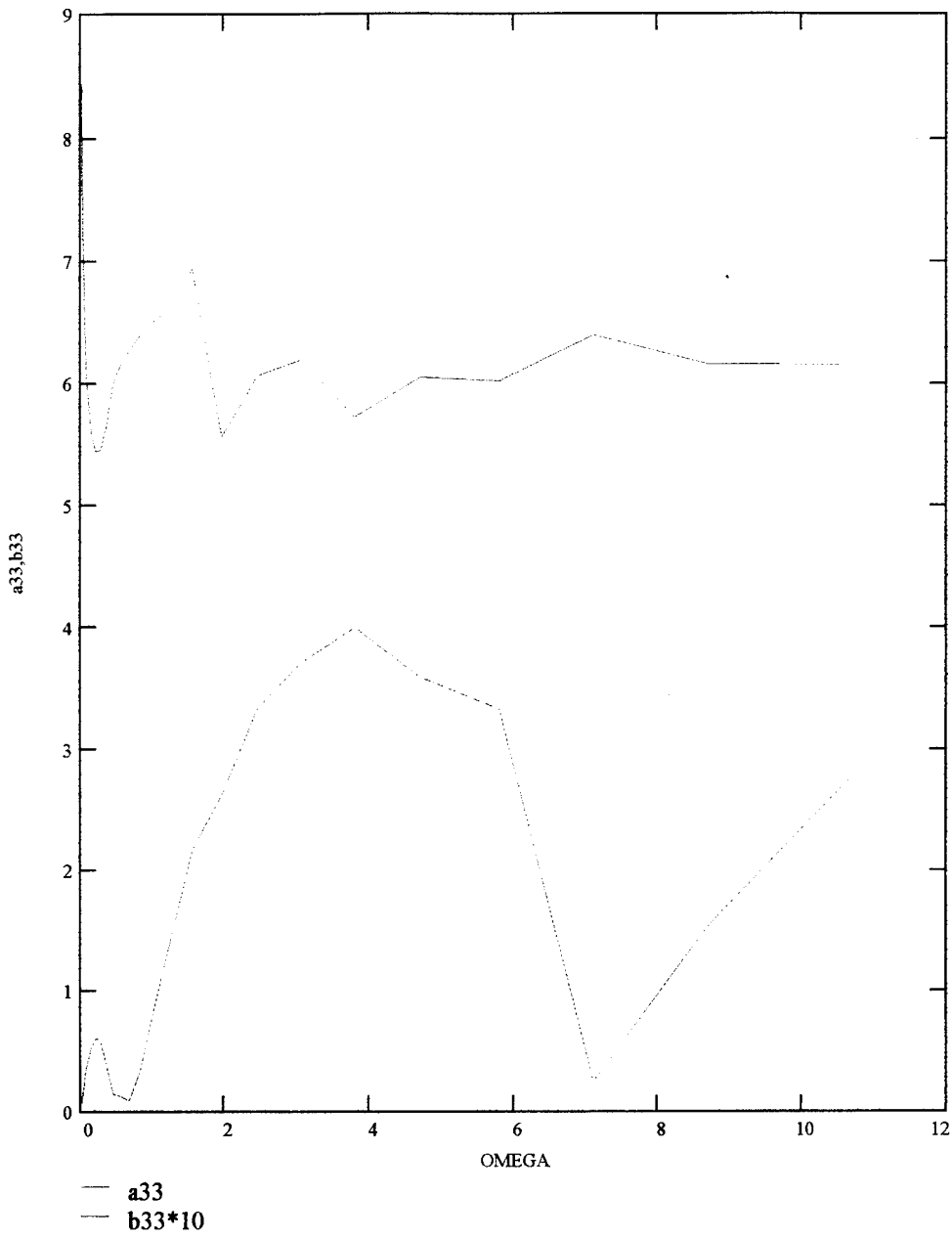

Figure 33. Station 15

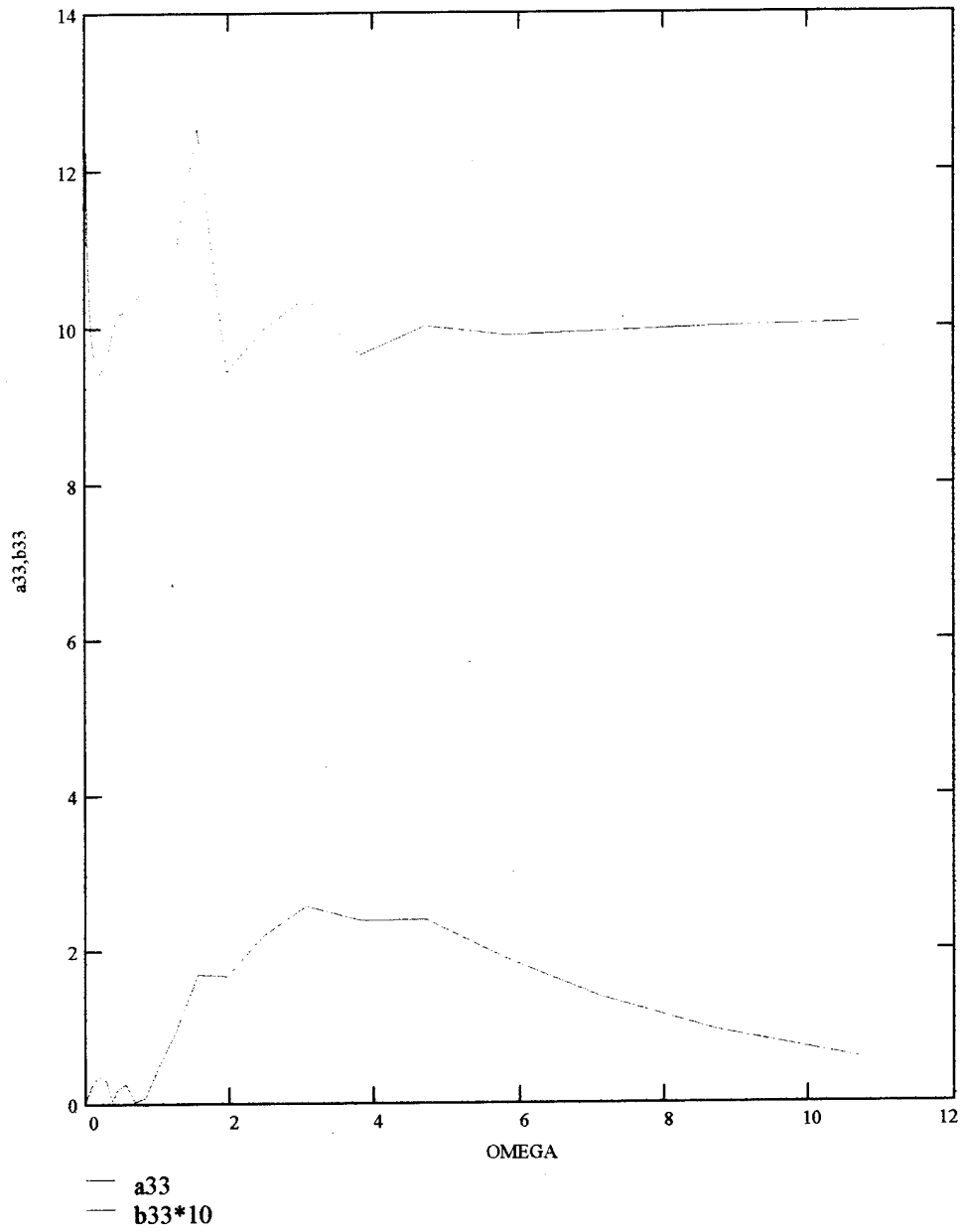

Figure 34. Station 16

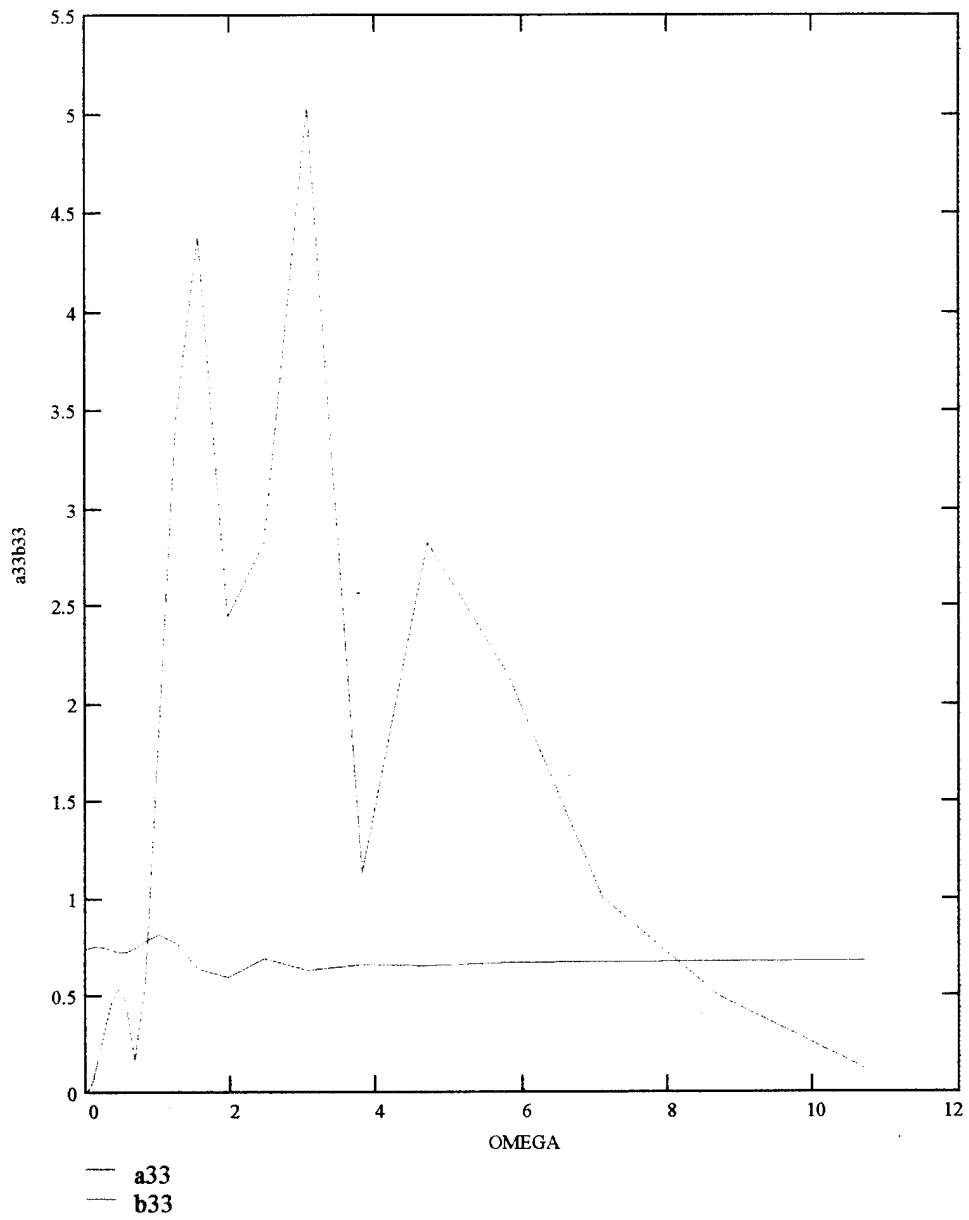

Figure 35. Station 17

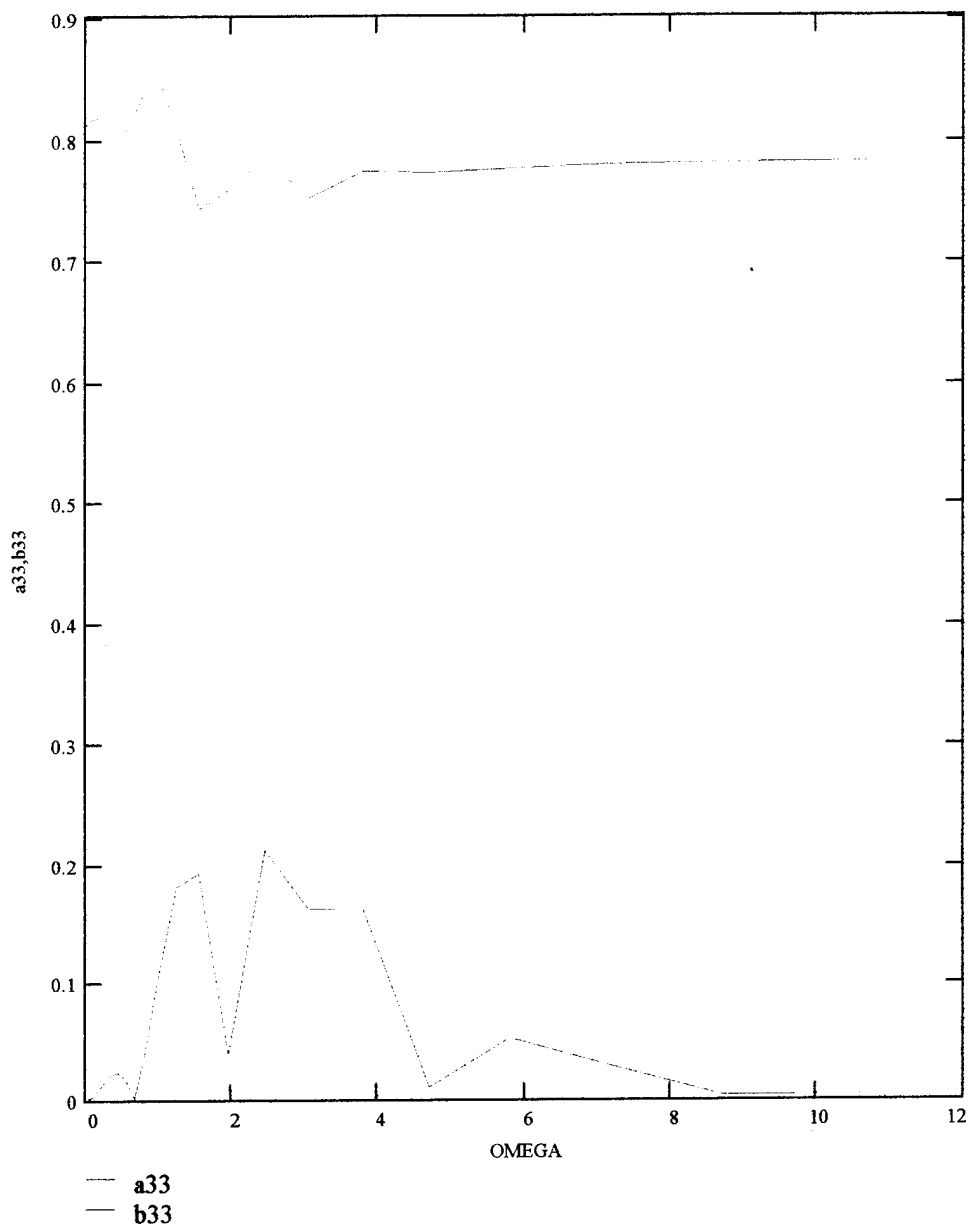

Figure 36. Station 18

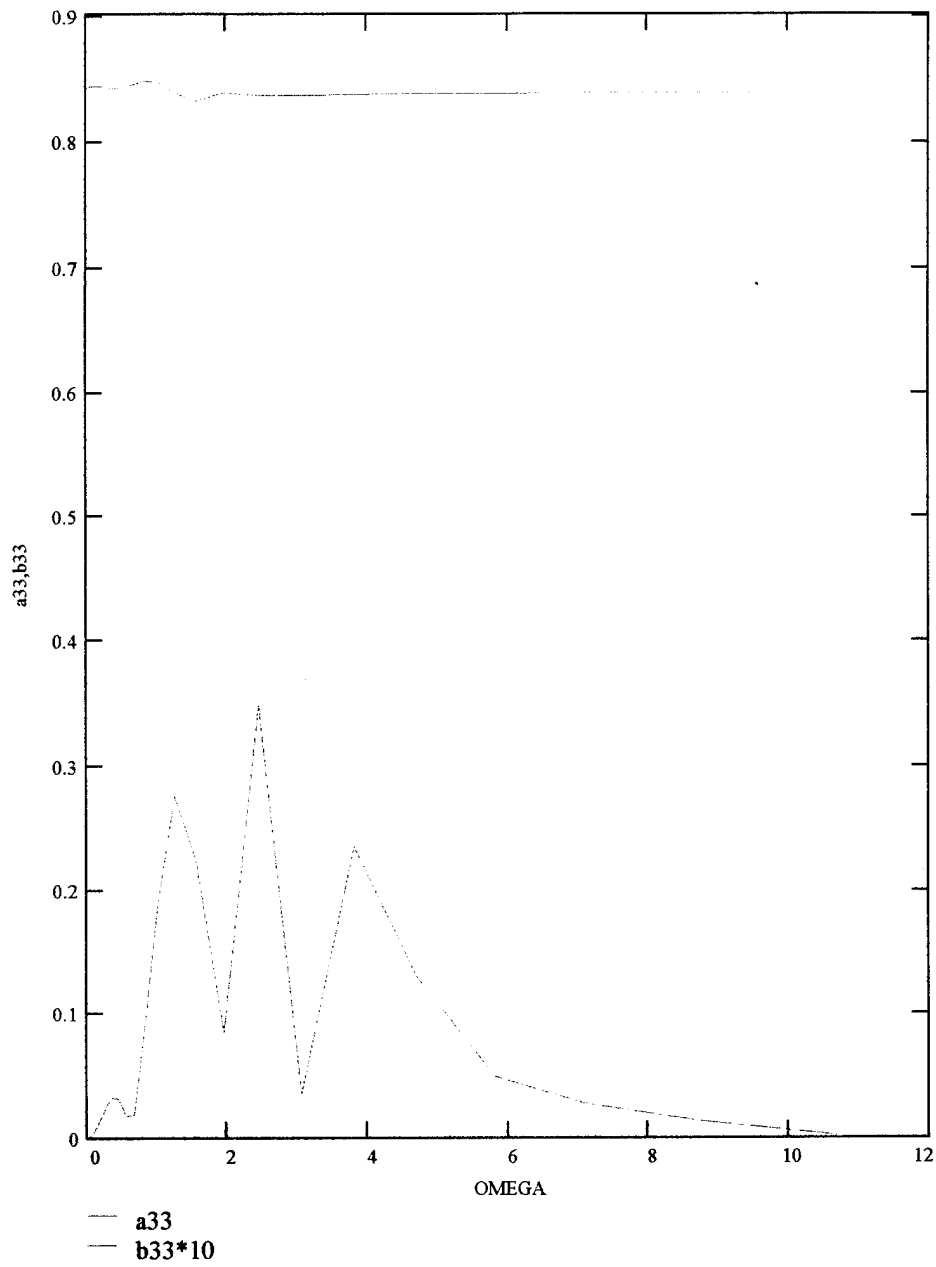

Figure 37. Station 19

## 2. Total Added Mass and Damping Coefficients

The total added mass and damping coefficients for the entire hull shape was calculated for zero speed and the data is presented in Figures 37-38. The hydrodynamic coefficients  $A_{33}$ ,  $A_{35}$ ,  $A_{55}$ ,  $B_{33}$ ,  $B_{35}$ , and  $B_{55}$  are graphed versus the wave frequencies. These results are presented in nondimensional form and they are calculated in the same manner as the sectional added mass and damping coefficients were in the previous section. These results are very similar to the results found for the SWATH hull thus this also justifies the use of the strip theory approach and the SHIPMO computer program.

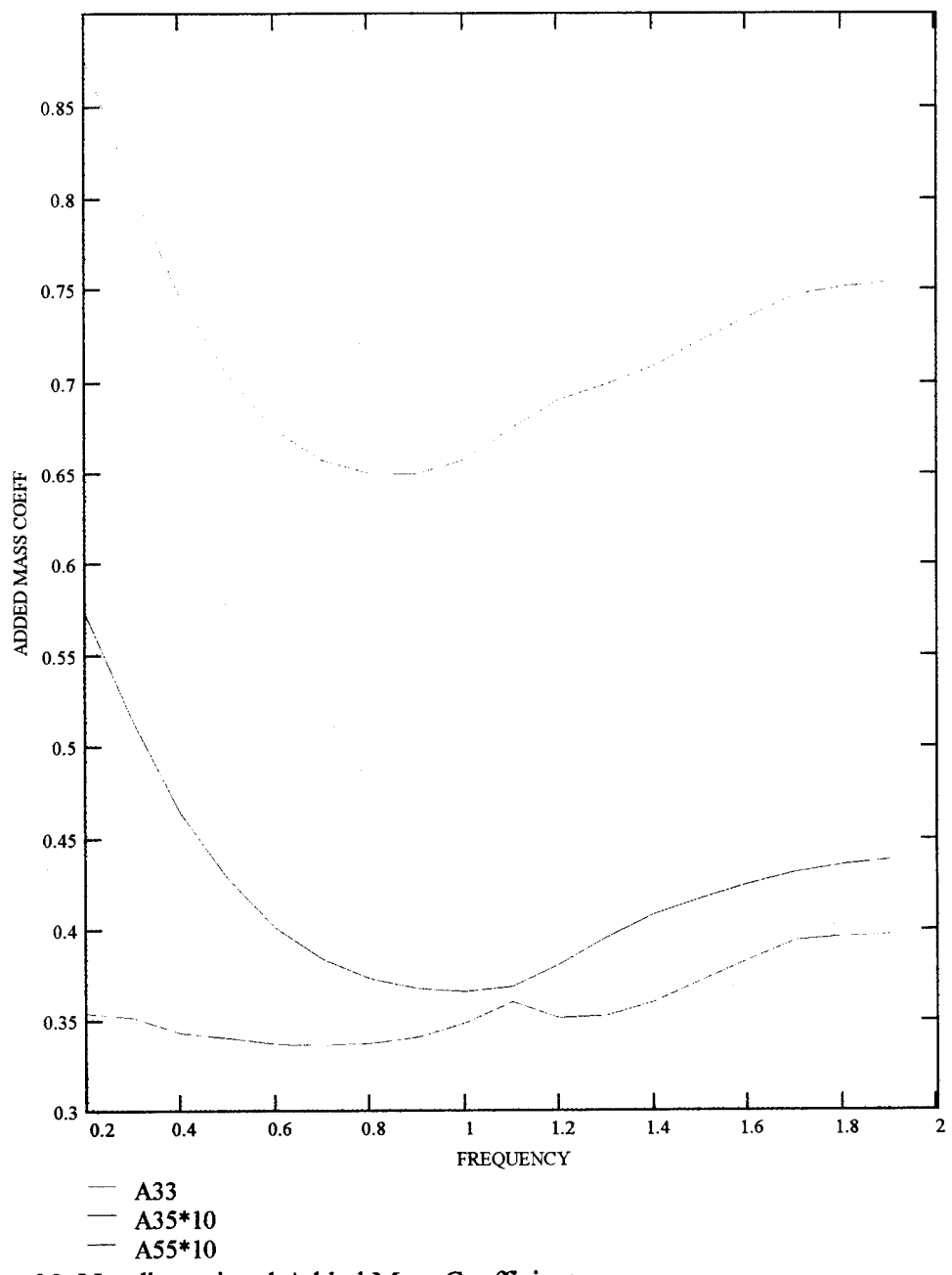

Figure 38. Nondimensional Added Mass Coefficients

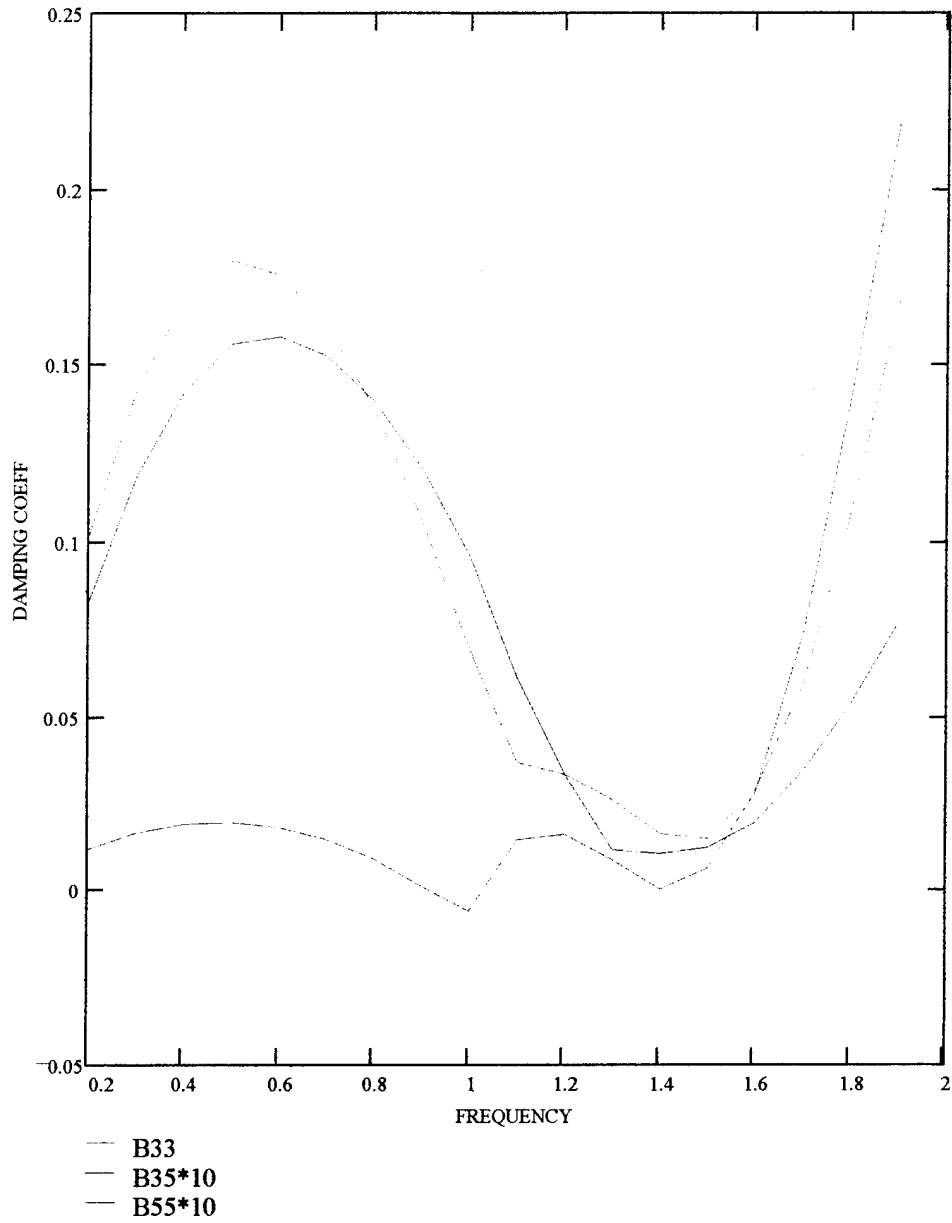

Figure 39. Nondimensional Damping Coefficients

## C. RESPONSE AMPLITUDE OPERATORS

### 1. Different Ship Speeds

The response amplitude operator, RAO, shows the amount of motion amplitude per unit wave height. All the results from the computer program are nondimensional. The RAO's for heave and pitch are calculated and analyzed for different ship speeds. The results are presented in Figures 40-61 and the data is graphed with the heave and pitch amplitudes versus wave to ship length for speeds of zero to twenty-five knots. The heave RAO shows the amount of heave per wave amplitude and for this computer input the wave amplitude was 1 foot. The heave and pitch data graphed in the following figures are in nondimensional form and the data is nondimensionalized by the following equations:

$$\zeta_3^* = \zeta_3 / \text{wave amplitude (heave)}$$
$$\zeta_5^* = \zeta_5 / (\text{wave amplitude} \times \text{wave number}) \text{ (pitch)}$$

The heave data is self explanatory with its presentation. The pitch information requires more calculations in order to make it understandable. The nondimensionalizing of the pitch varies with the wavelength because of the wave number which is defined as  $2\pi/\text{wavelength}$ . An example of calculating the nondimensional pitch that corresponds to 15 degrees of pitch at a wave to ship length of one is as follows:

$$\zeta_5^* = \frac{15 \times \left( \frac{2\pi}{180} \right)}{\frac{2\pi}{108}}$$
$$\zeta_5^* = 9$$

For different wave to ship ratios this nondimensional number will change for a specific degree of pitch.

Some of the graphs have an unreasonable high peak at a certain wave to ship length and this is due to the fact that the computer program does not take into account the effects of viscous damping that can influence the results for a hull shape such as the SLICE. Neglecting this information only affects the amount of the amplitude and not the location of the heave or pitch resonant peak. Unlike monohull ships in which viscous damping has very little effect compared to the wave forces, viscous damping does have a significant amount of effect on a hull design such as the SLICE. Again this will only affect the magnitude of the results, while the trend of the data is still preserved. The resonant frequency of pitch increases as the speed increases for head on type waves. For beam and following waves, the resonant frequency slightly decreases as the speed increases. This same trend occurs for the heave period.

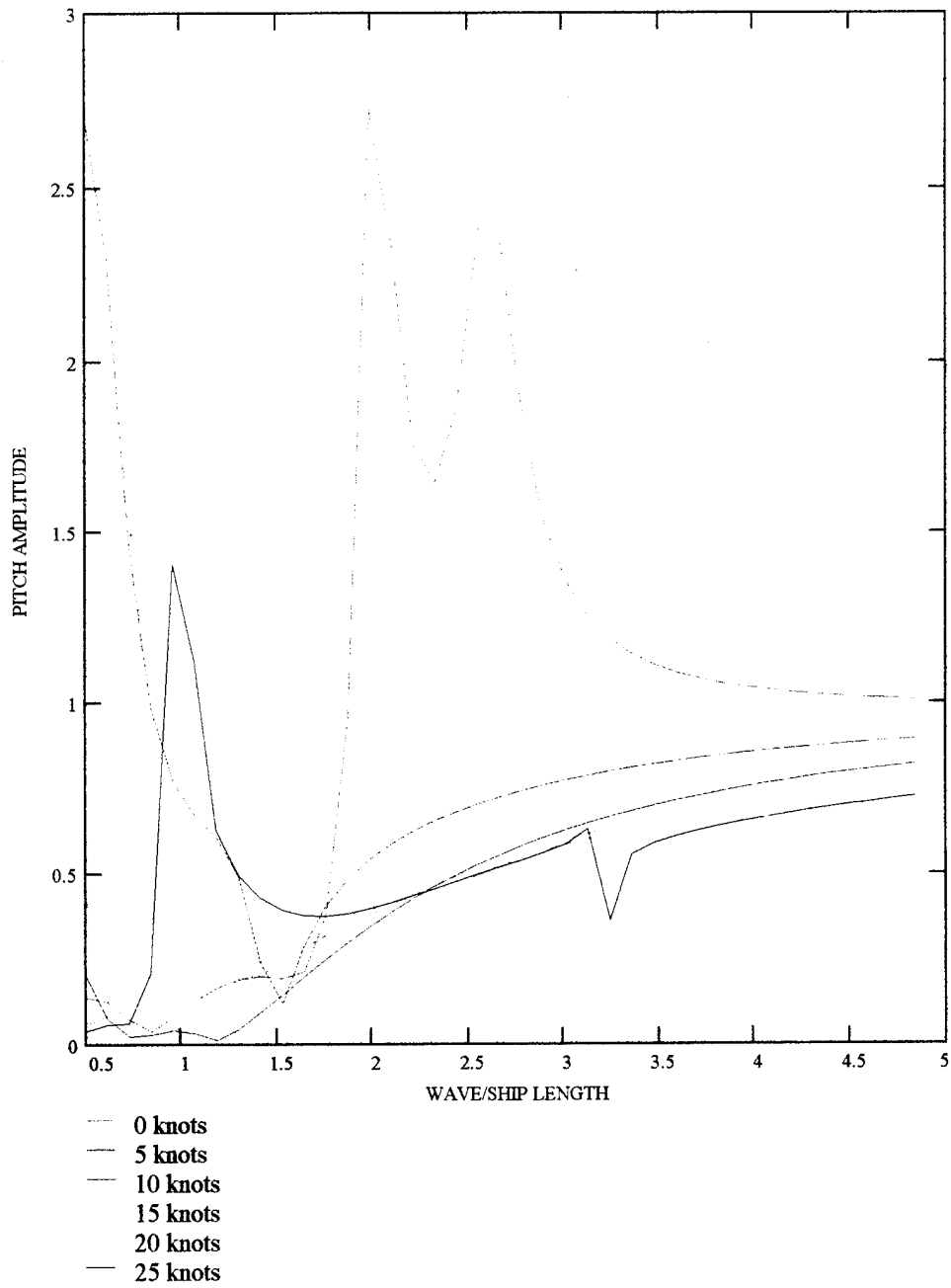

Figure 40. Wave Direction-0 Degrees, Speed 0-25 Knots

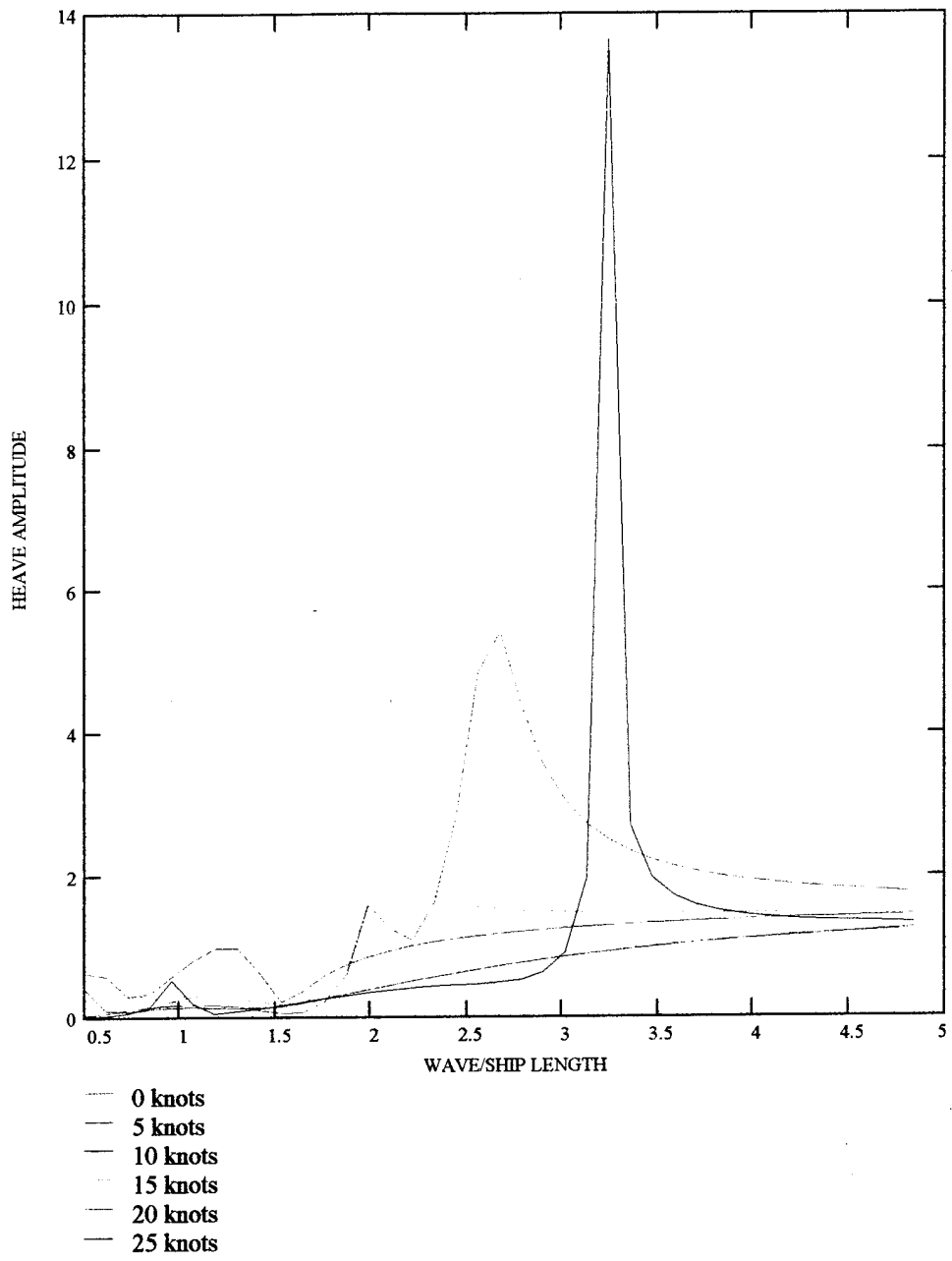

Figure 41. Wave Direction-0 Degrees, Speed 0-25 Knots

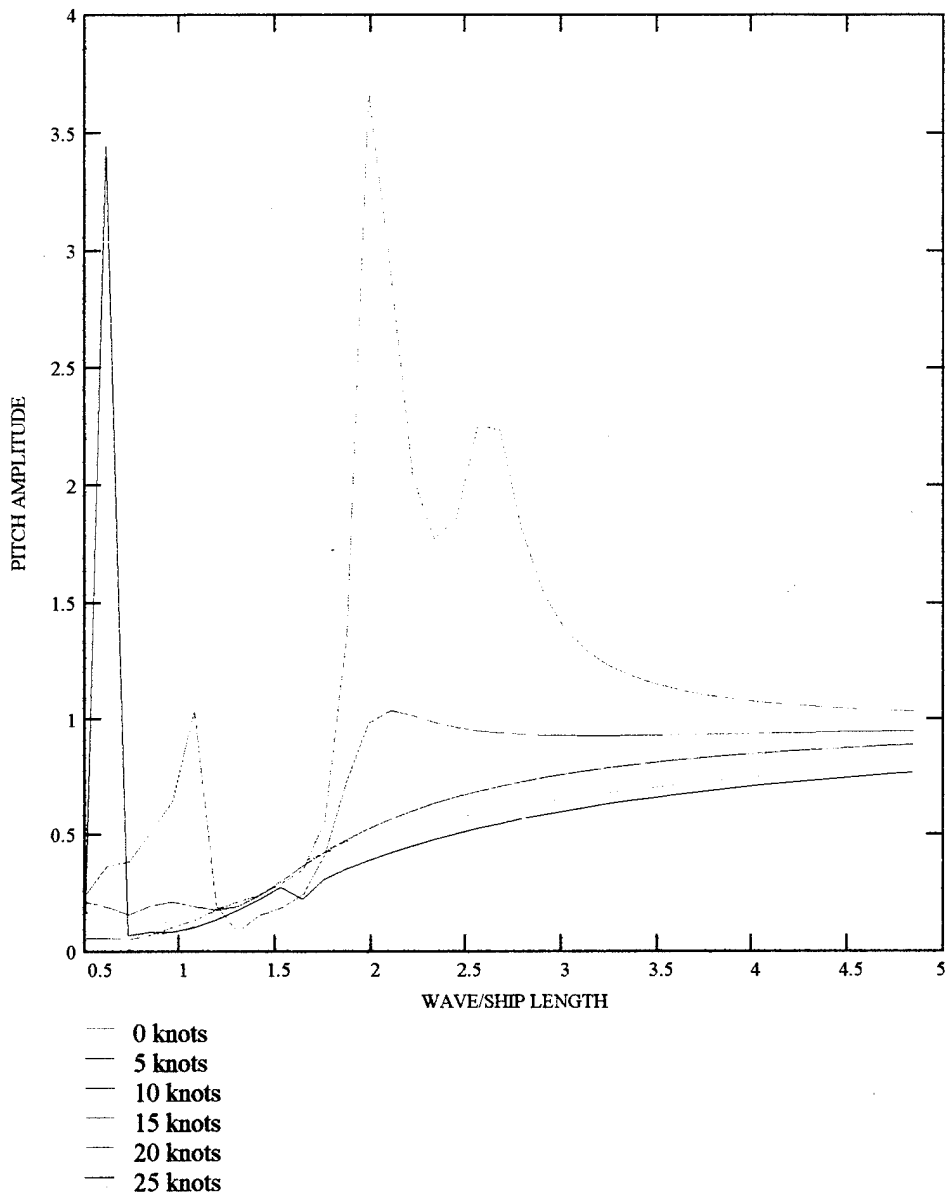

Figure 42. Wave Direction-45 Degrees, Speed 0-25 Knots

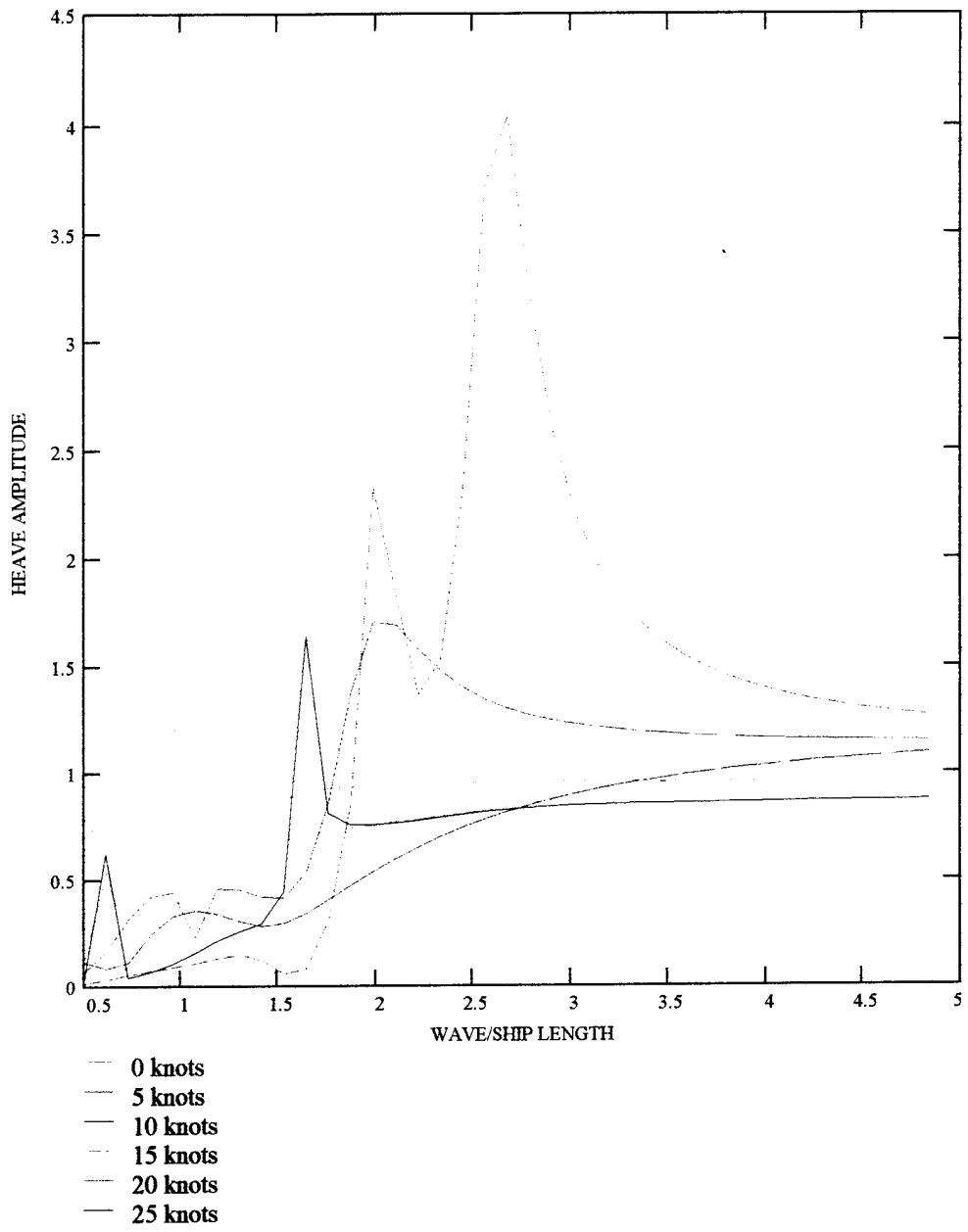

Figure 43. Wave Direction-45 Degrees, Speed 0-25 Knots

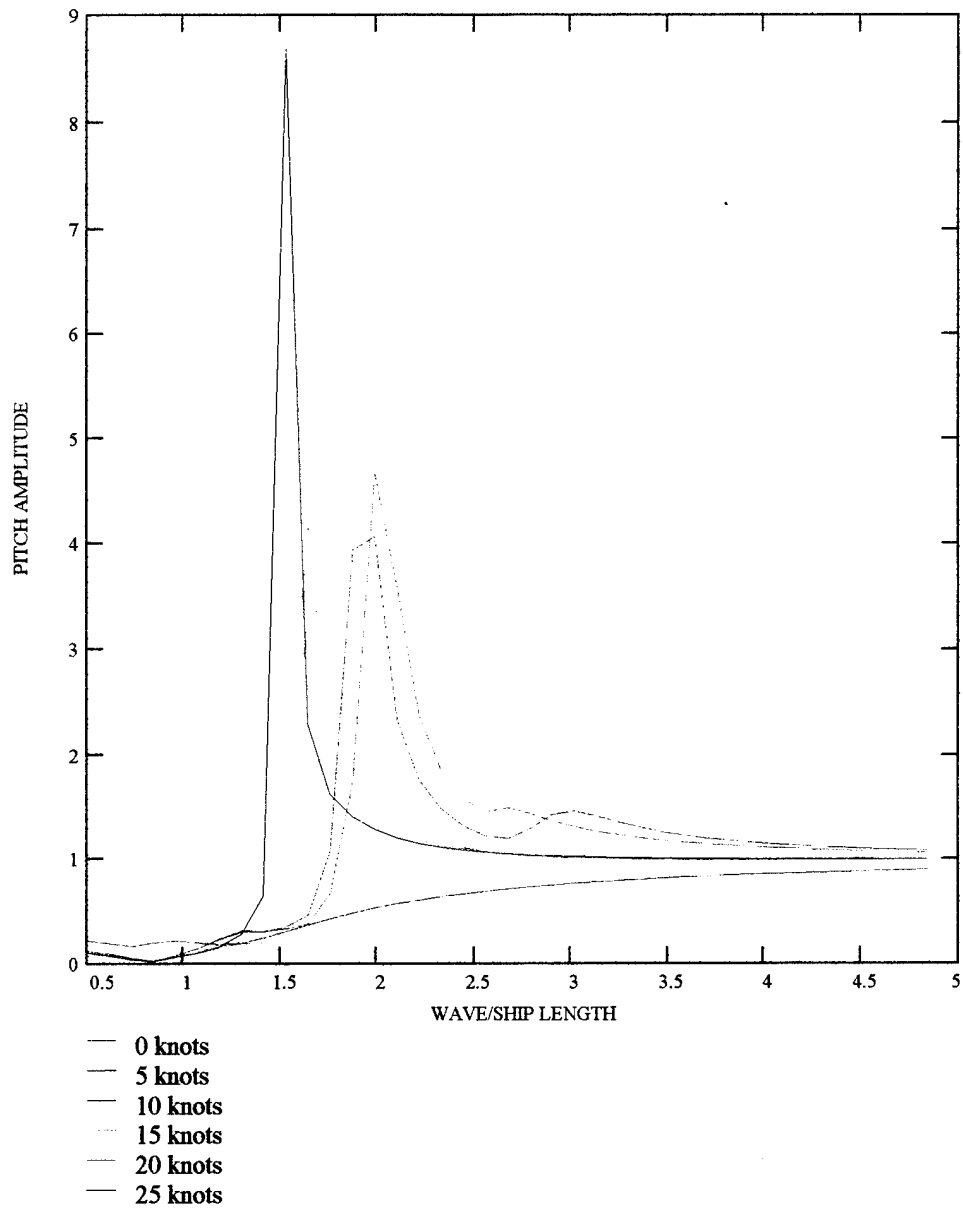

Figure 44. Wave Direction-90 Degrees, Speed 0-25 Knots

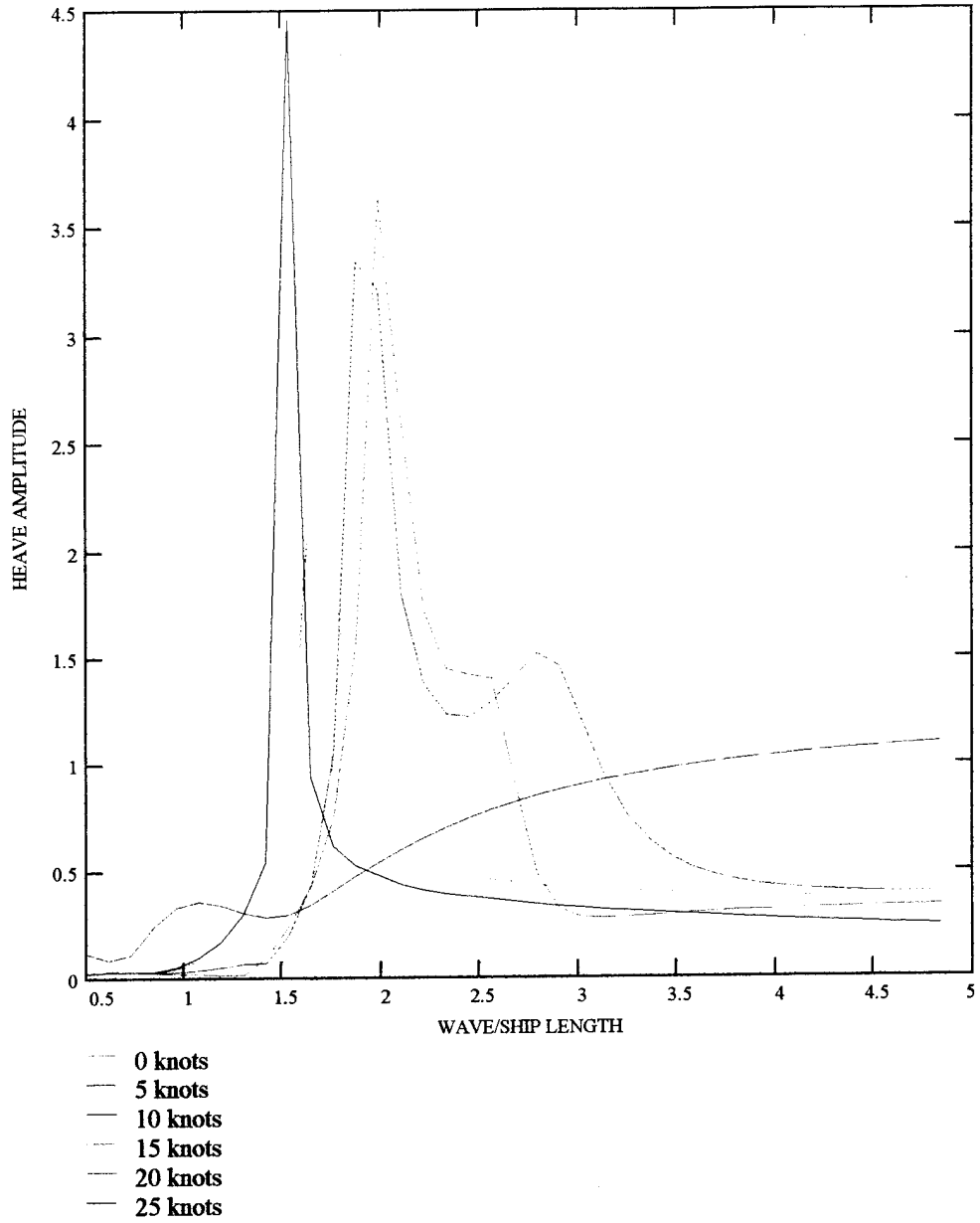

Figure 45. Wave Direction-90 Degrees, Speed 0-25 Knots

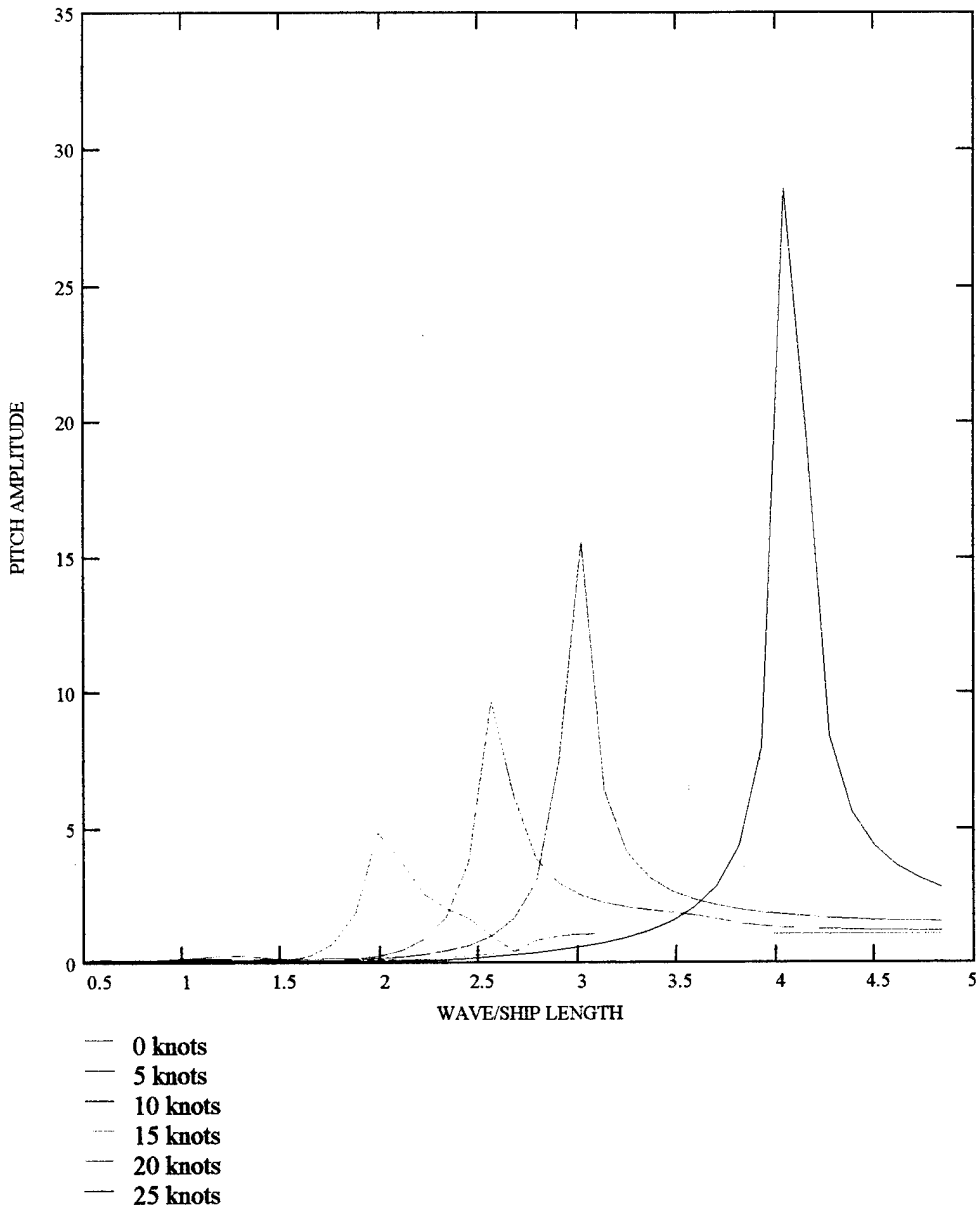

Figure 46. Wave Direction-135 Degrees, Speed 0-25 Knots

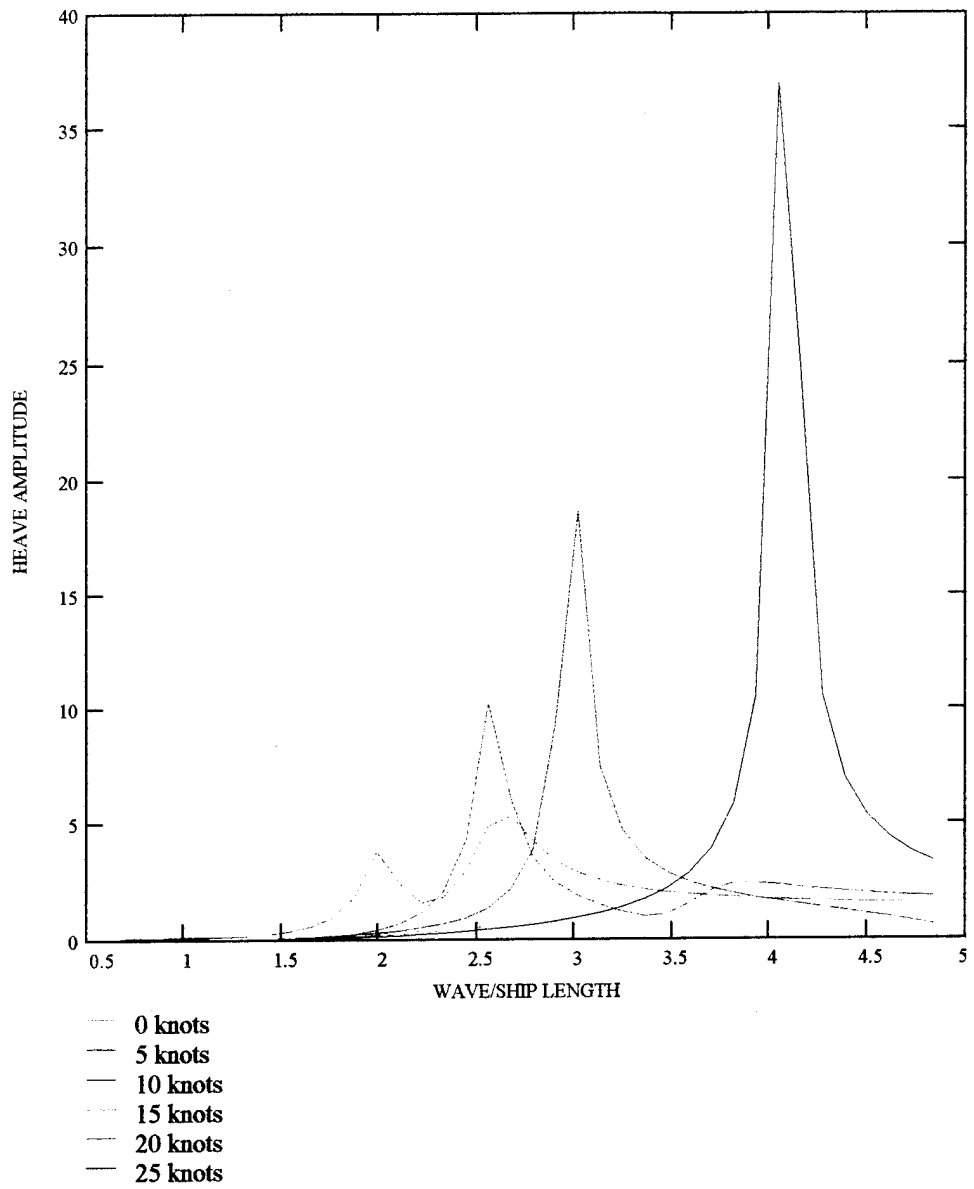

Figure 47. Wave Direction-135 Degrees, Speed 0-25 Knots

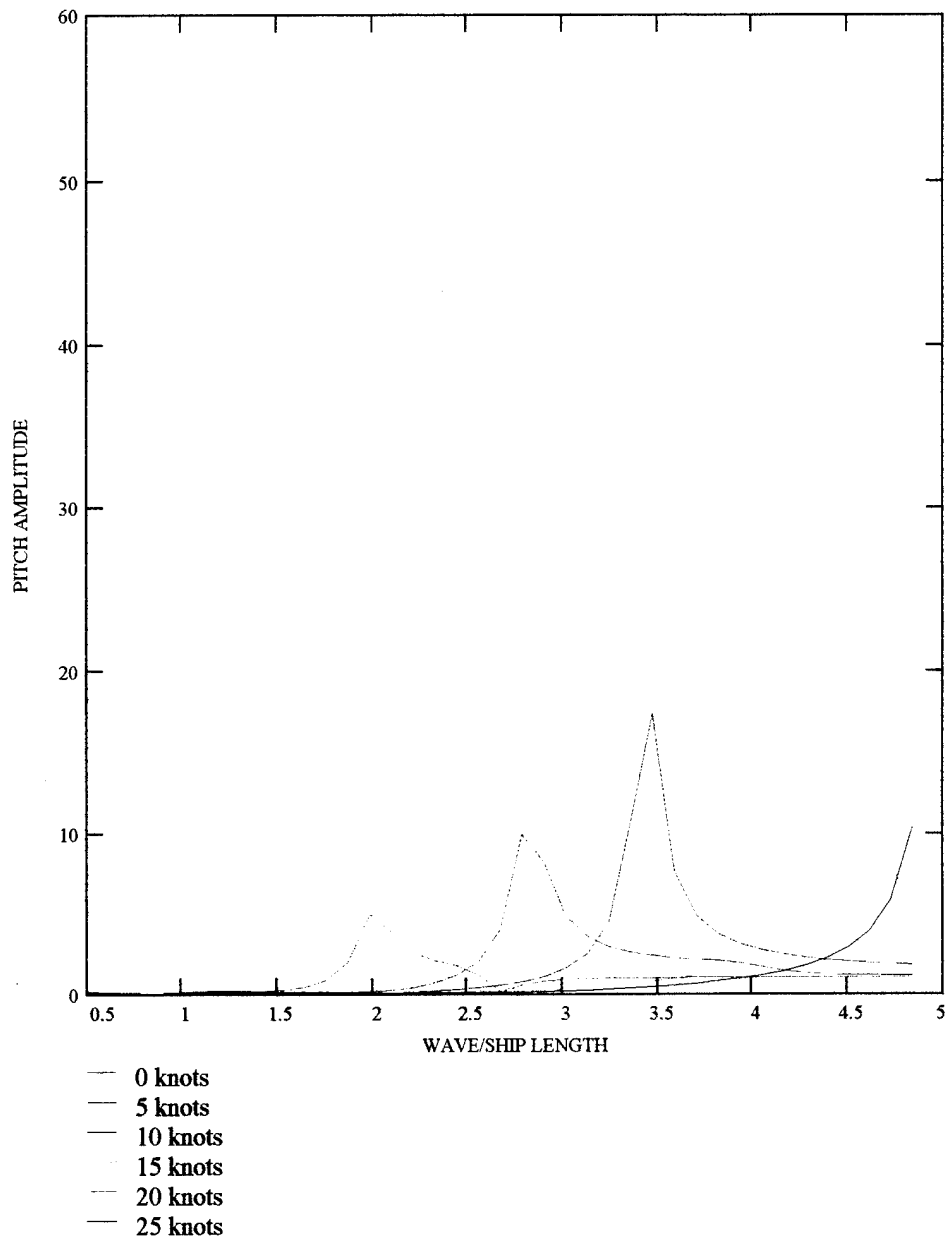

Figure 48. Wave Direction-180 Degrees, Speed 0-25 Knots

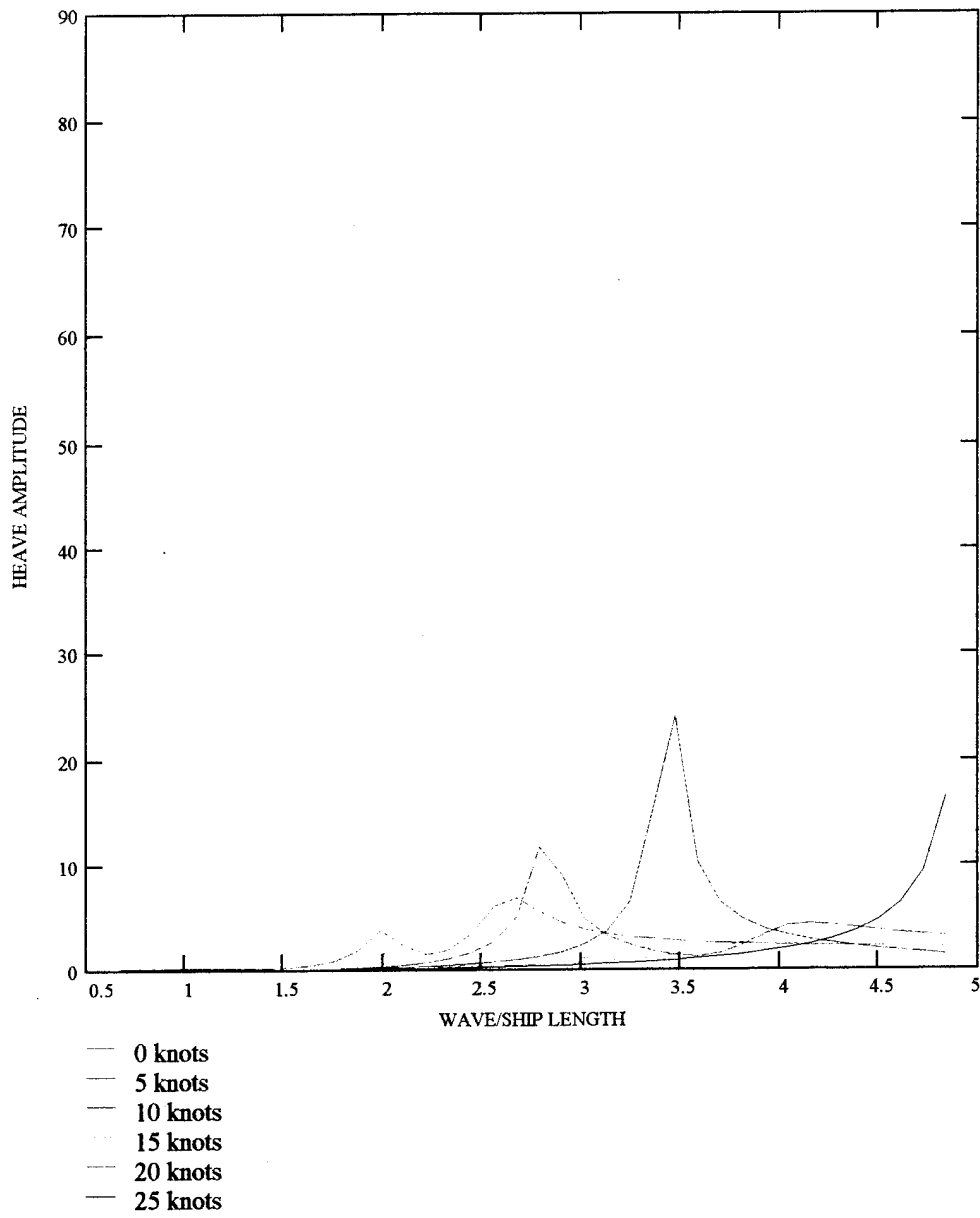

Figure 49. Wave Direction-180 Degrees, Speed 0-25 Knots

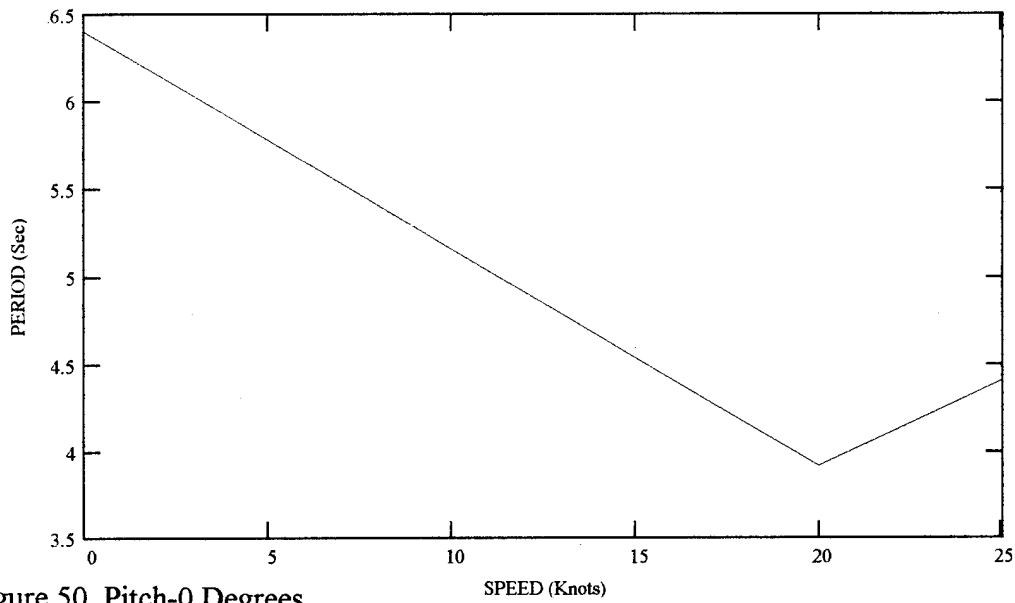

Figure 50. Pitch-0 Degrees

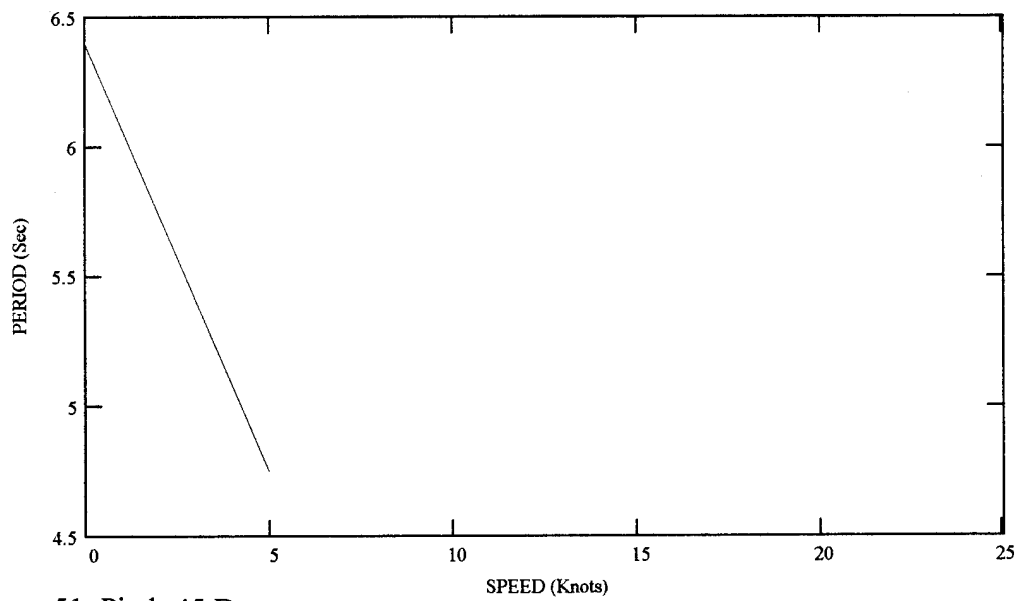

Figure 51. Pitch-45 Degrees

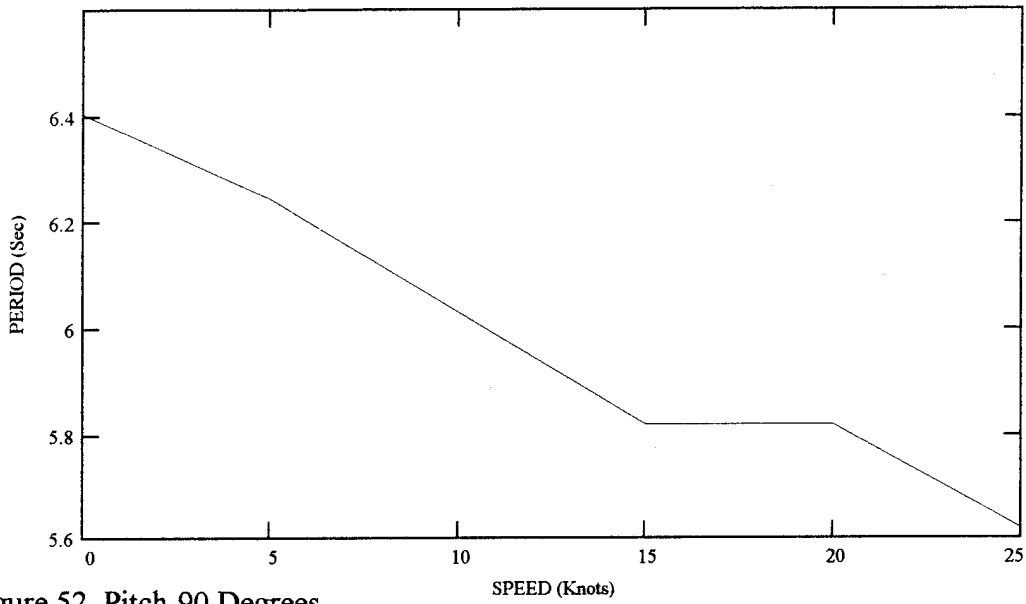

Figure 52. Pitch-90 Degrees

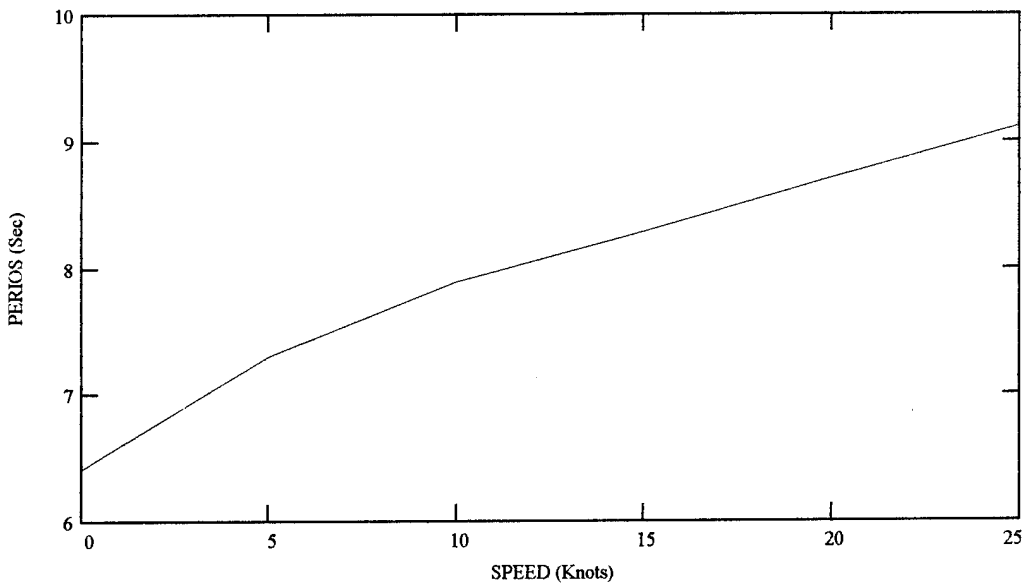

Figure 53. Pitch-135 Degrees

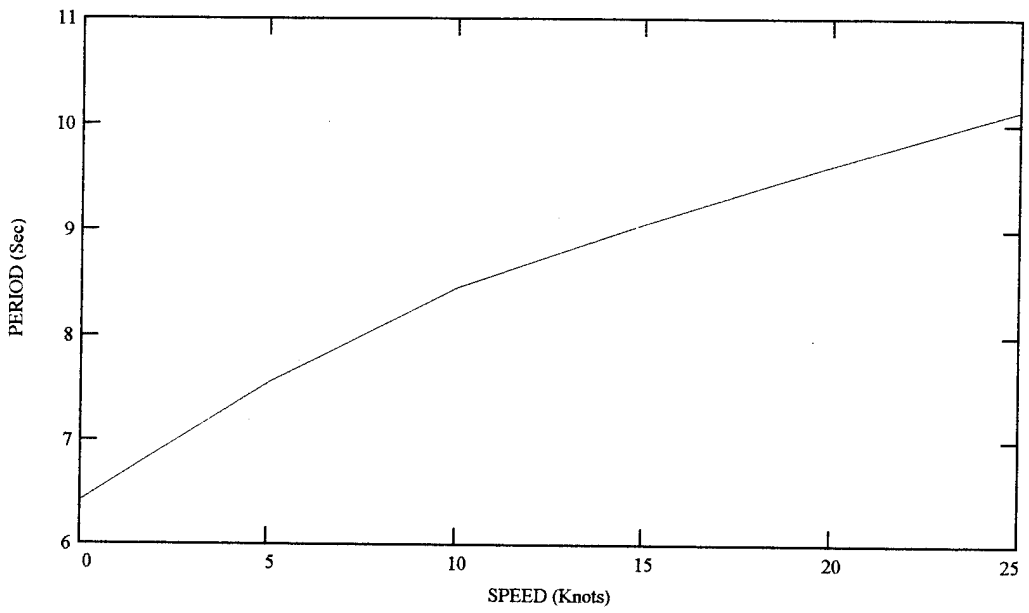

Figure 54. Pitch-180 Degrees

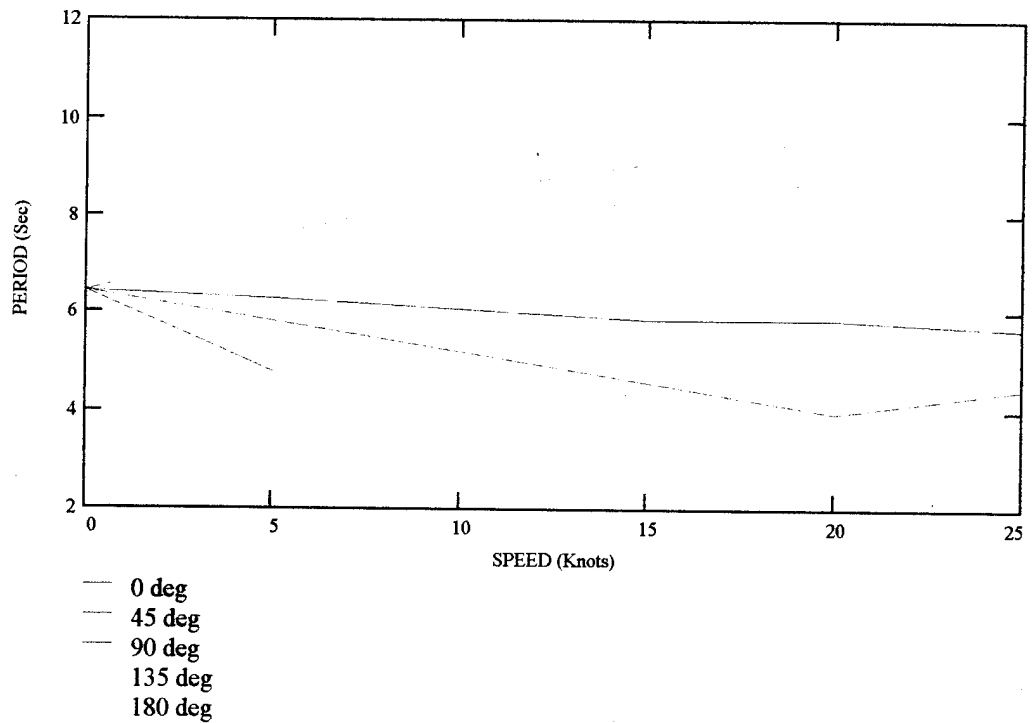

Figure 55. Pitch-All Angles

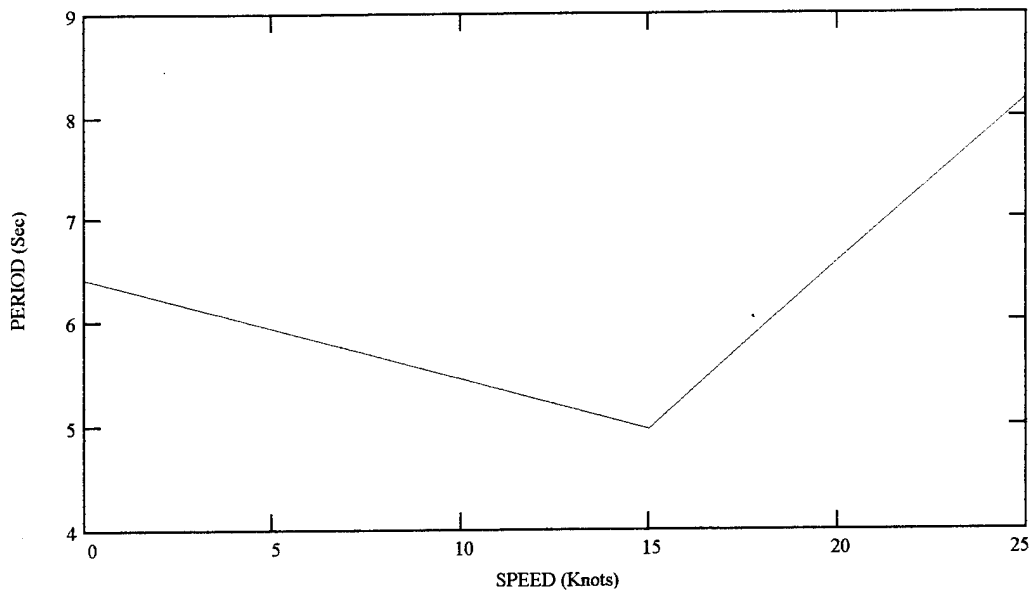

Figure 56. Heave-0 Degrees

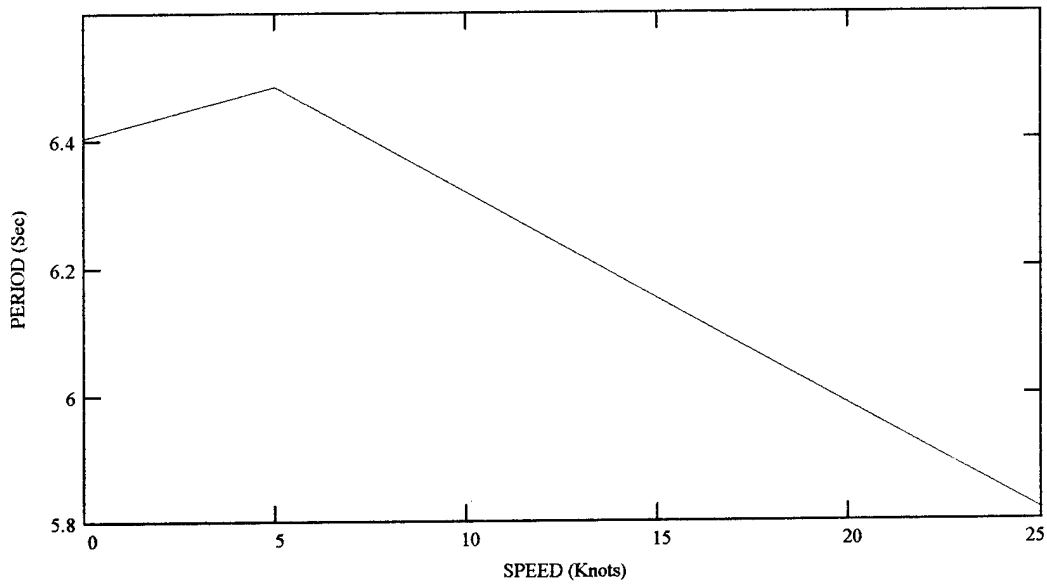

Figure 57. Heave-45 Degrees

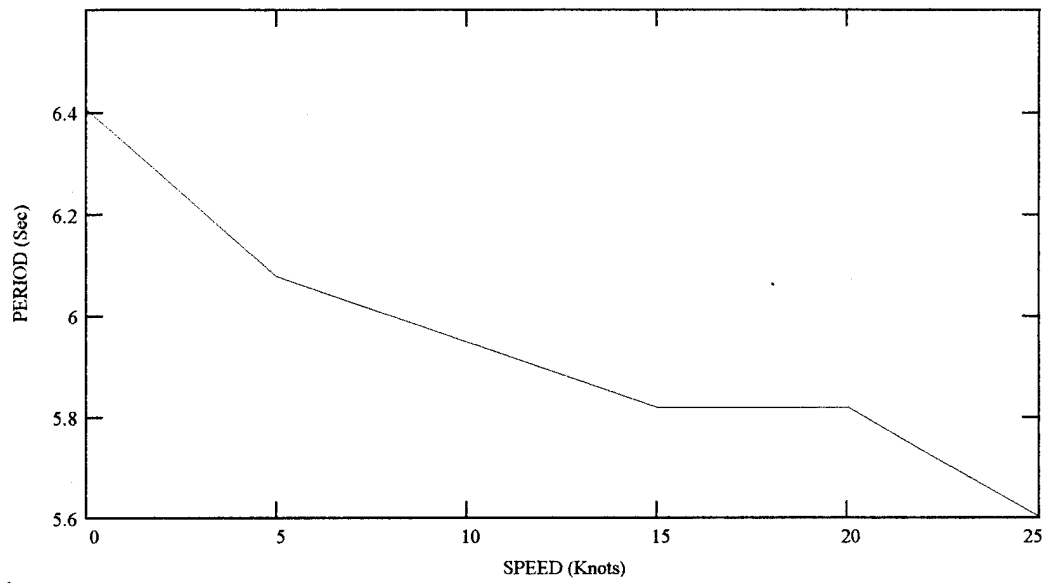

Figure 58. Heave-90 Degrees

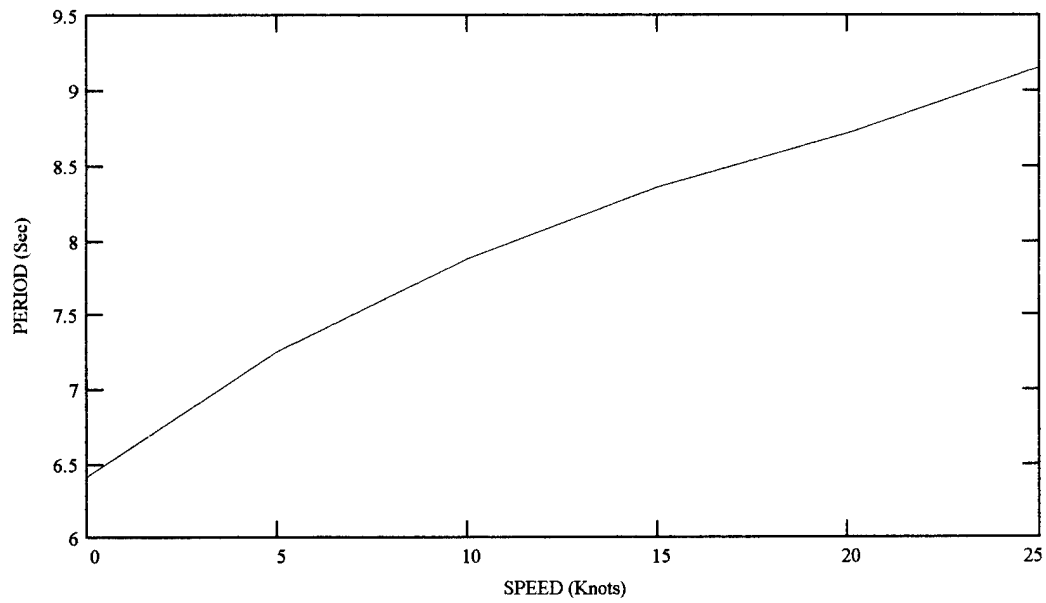

Figure 59. Heave-135 Degrees

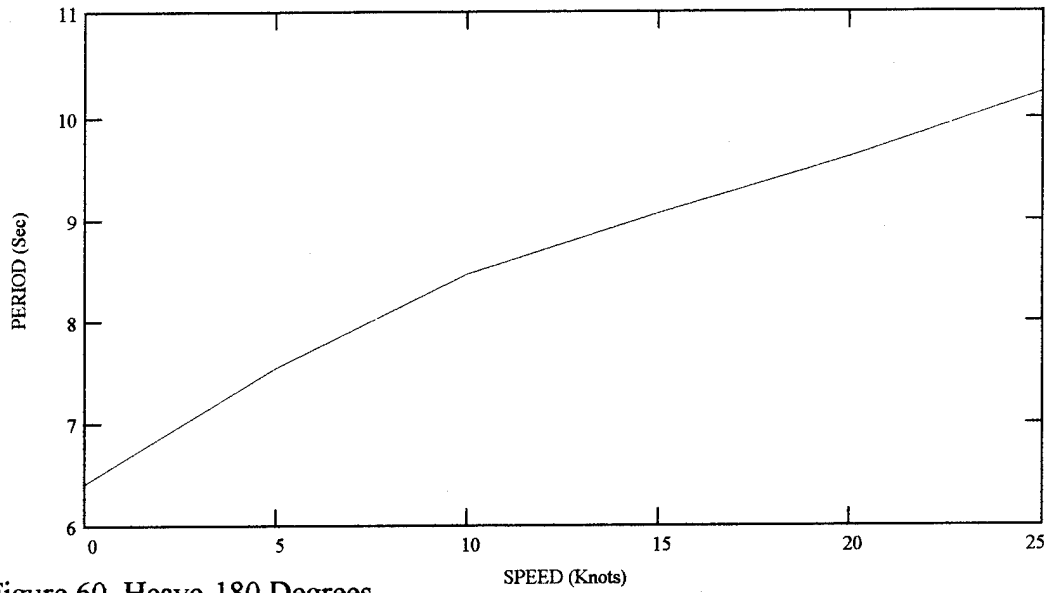

Figure 60. Heave-180 Degrees

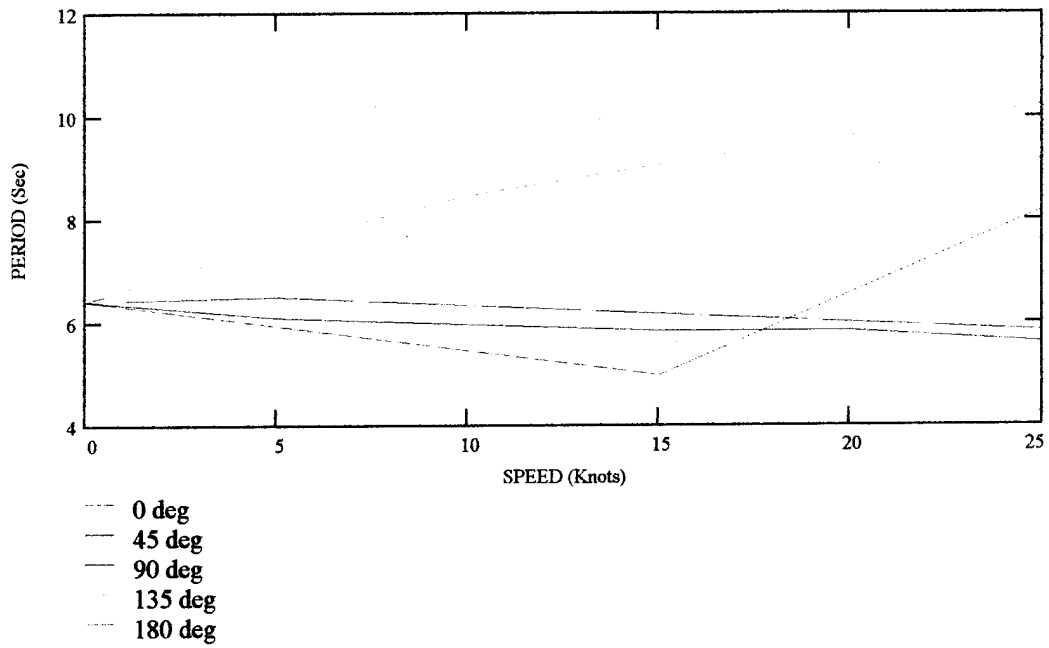

Figure 61. Heave-All Angles

## 2. Different Wave Directions

The RAO's for the heave and pitch motion were calculated for different wave directions and ship speed. The wave direction varied from head on seas to following seas in 45 degree increments. Figure 62 explains the relationship between the wave direction and the ship's heading.

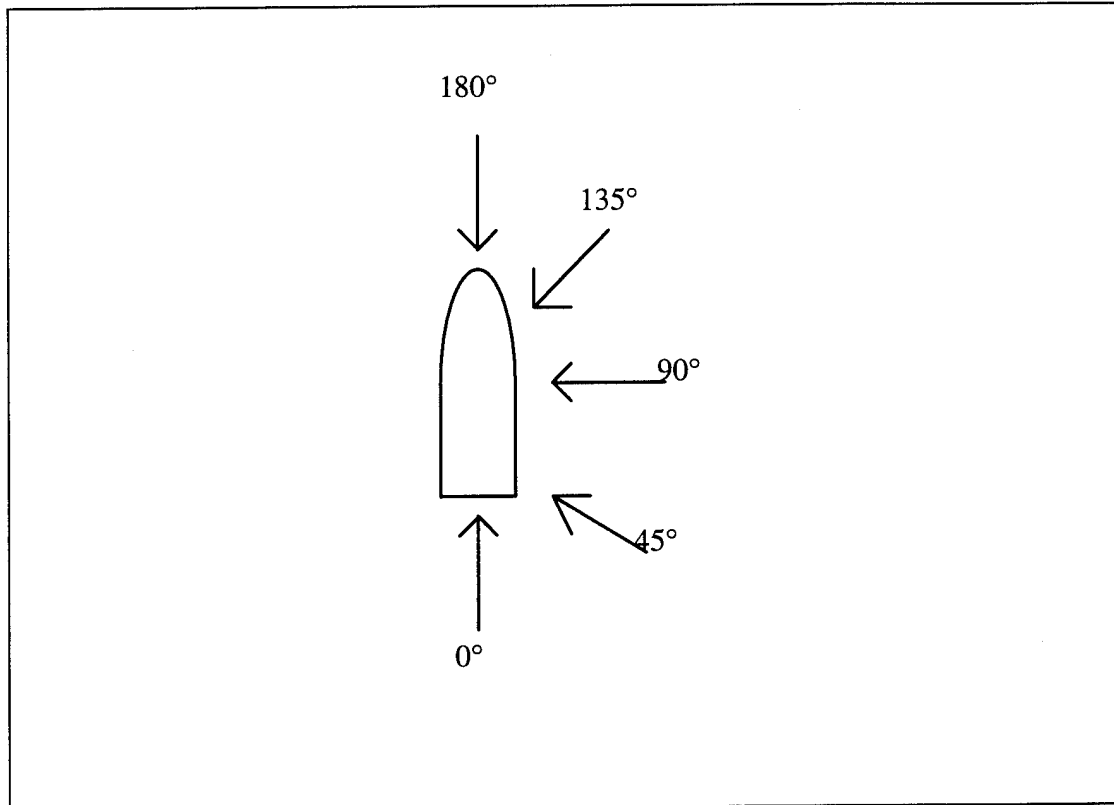

Figure 62. Wave Direction in Respect to Ship Heading

The heave and pitch RAO's are in the some nondimensional form that was explained in the previous section. The pitch natural period increases for different speeds as the wave direction moves from a following sea to a head on sea. The same phenomenon occurs for the heave natural period. Figures 63-92 show the relationship between heave and pitch and wave direction.

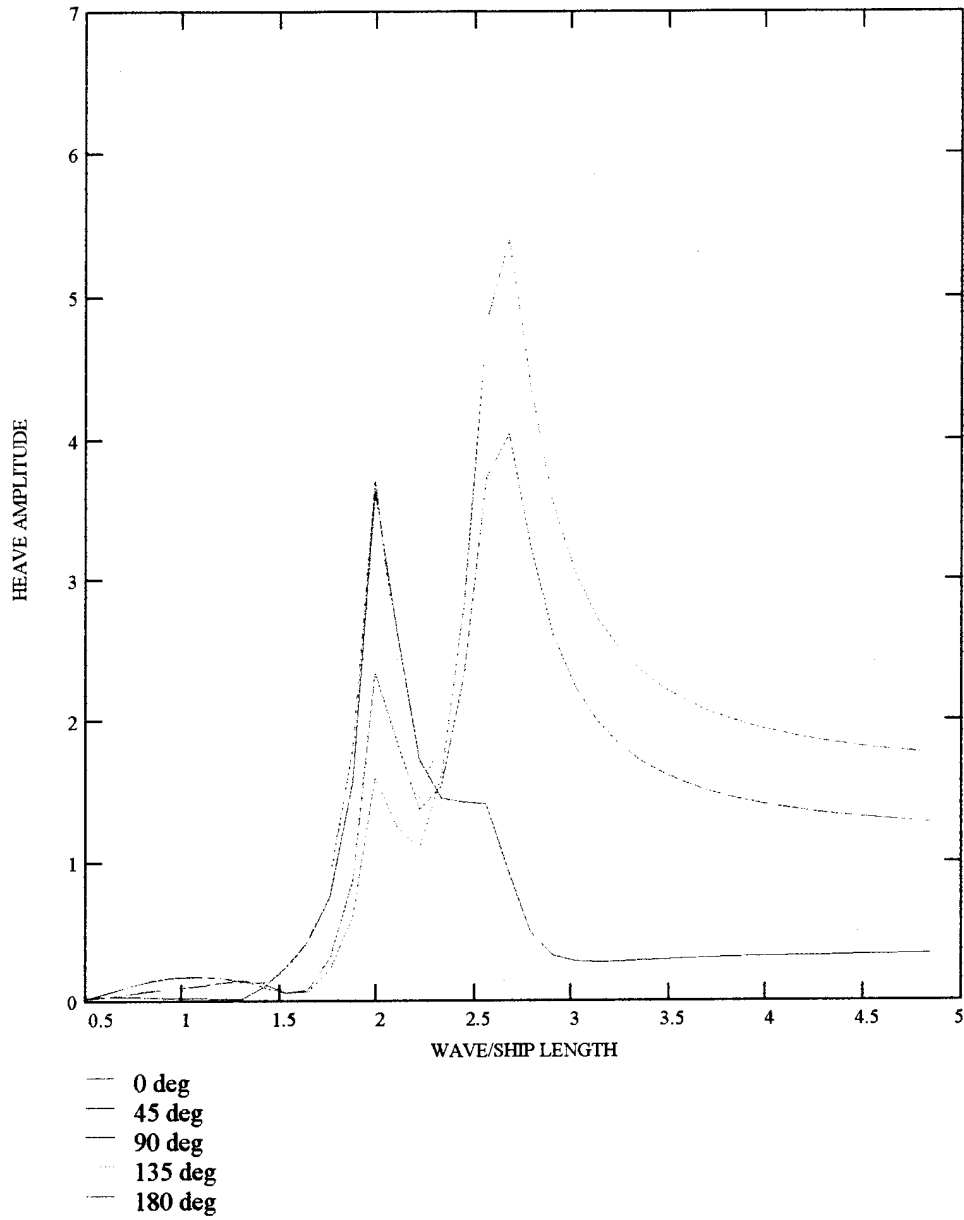

Figure 63. Speed 0 knots

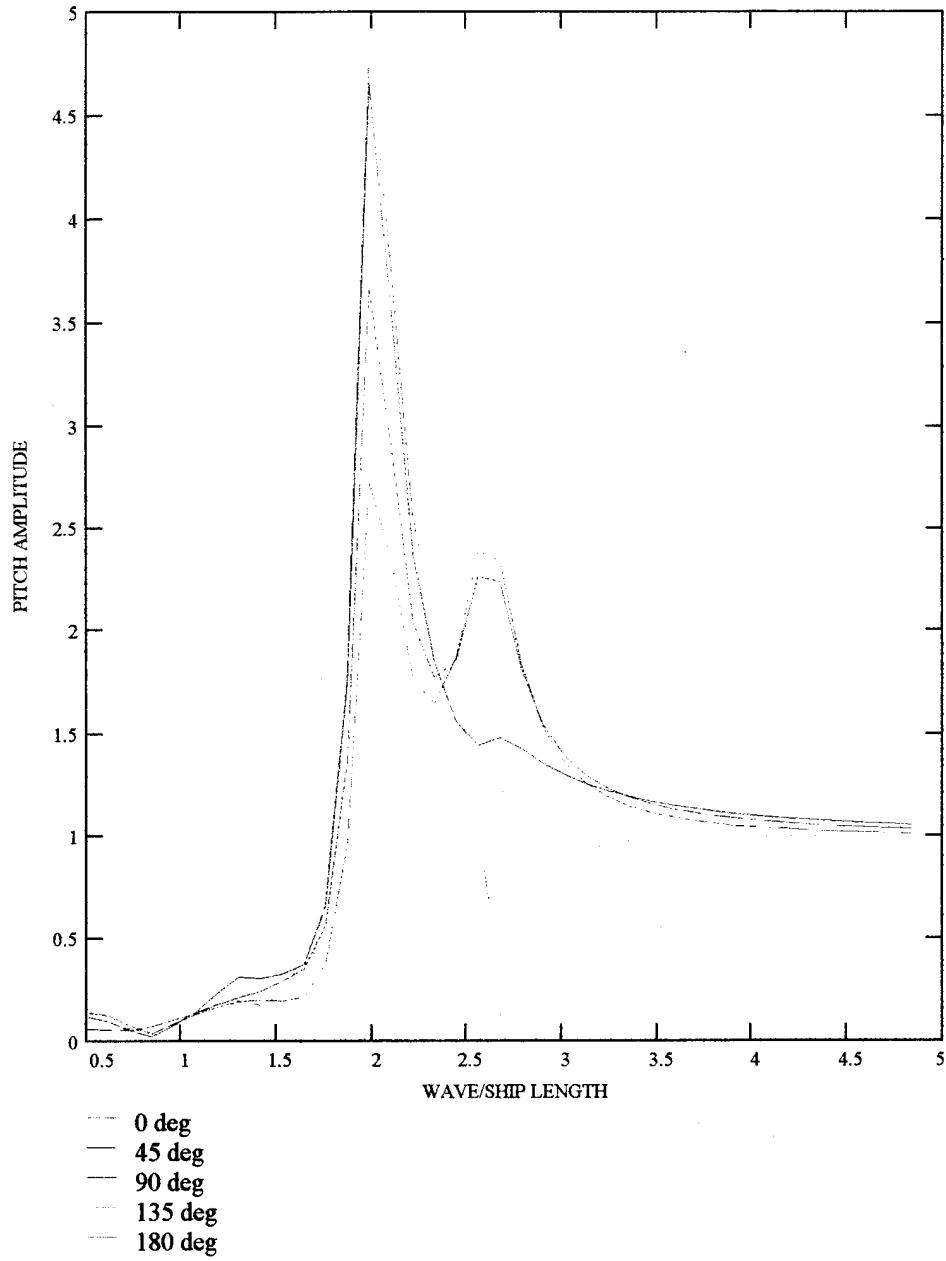

Figure 64. Speed 0 knots

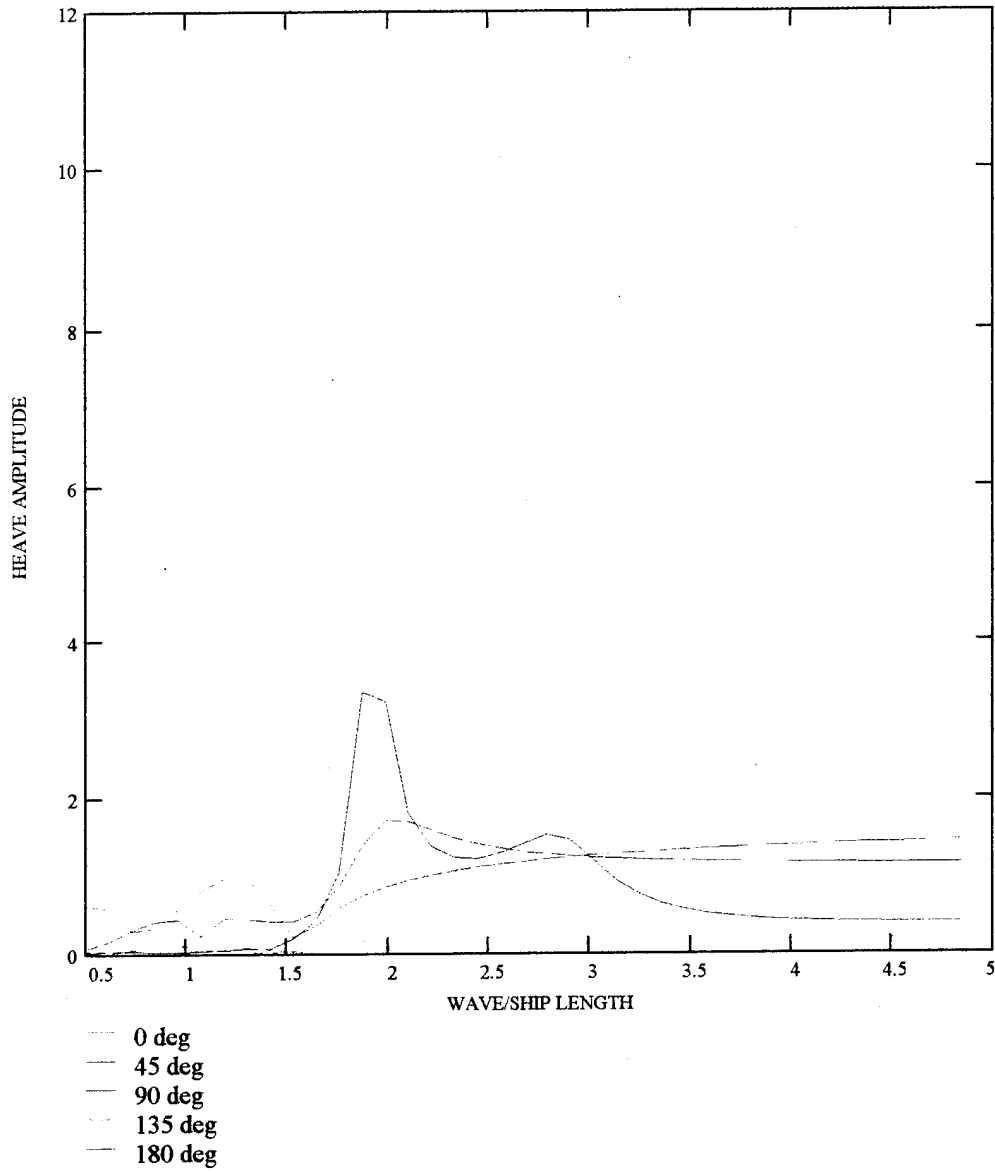

Figure 65. Speed 5 knots

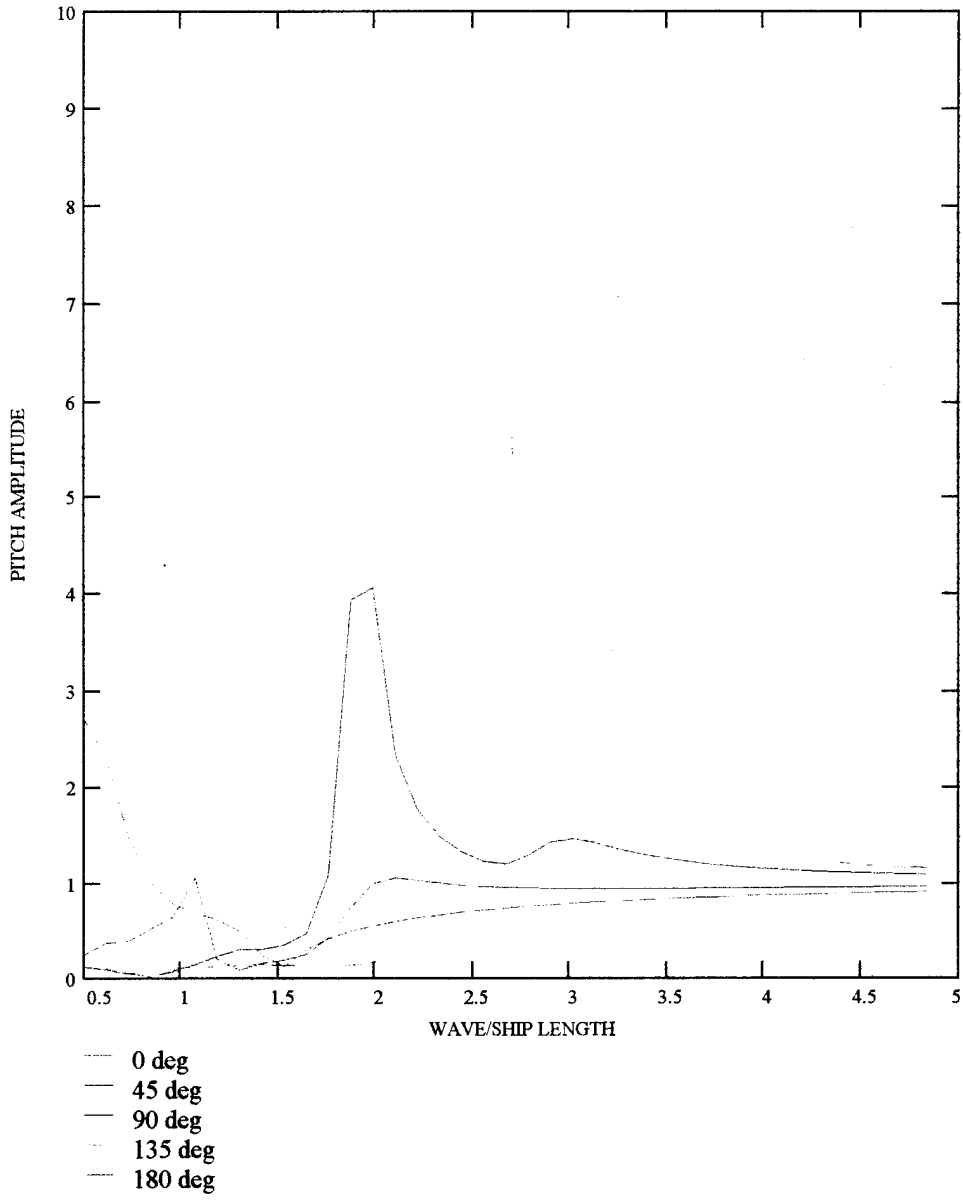

Figure 66. Speed 5 knots

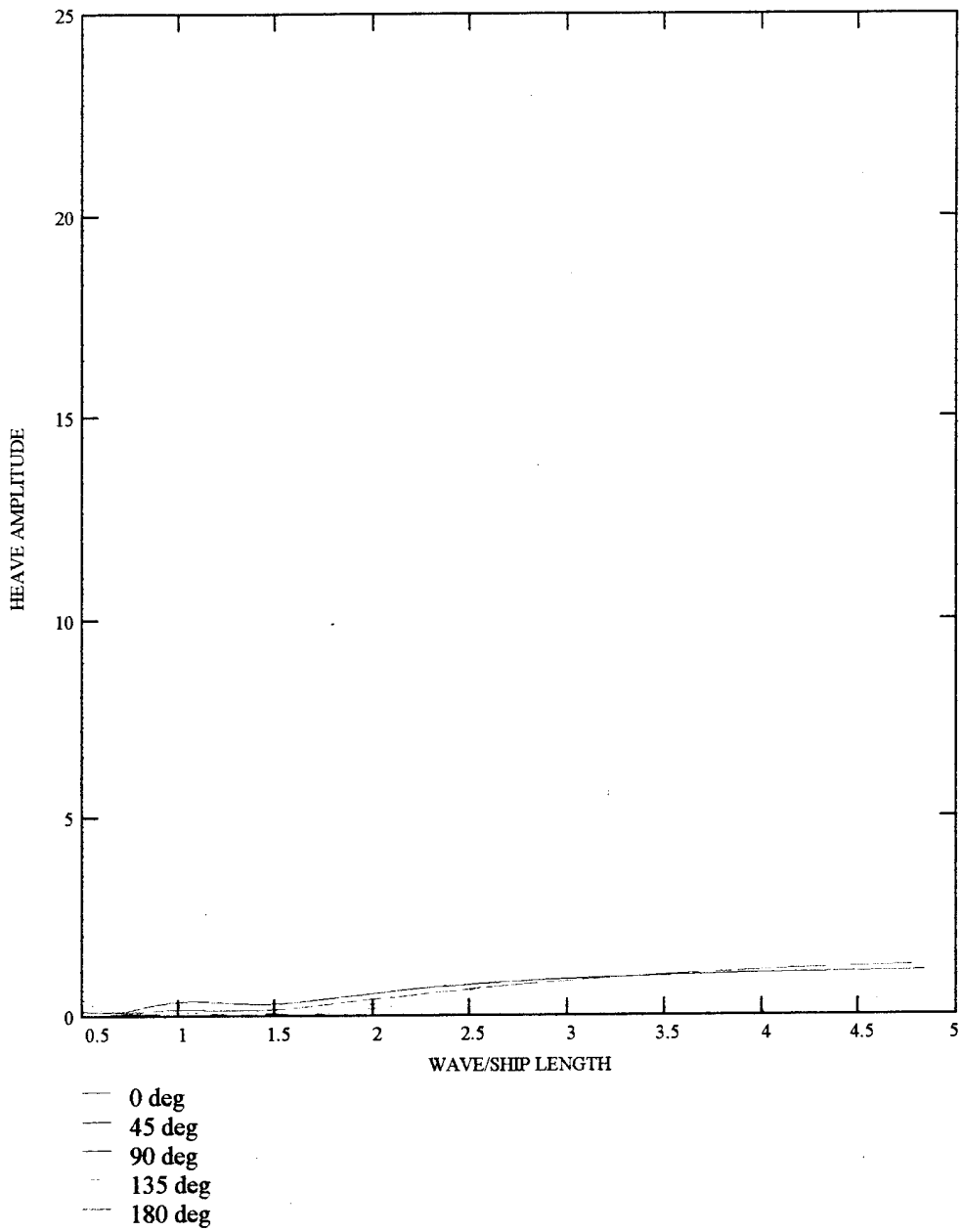

Figure 67. Speed 10 knots

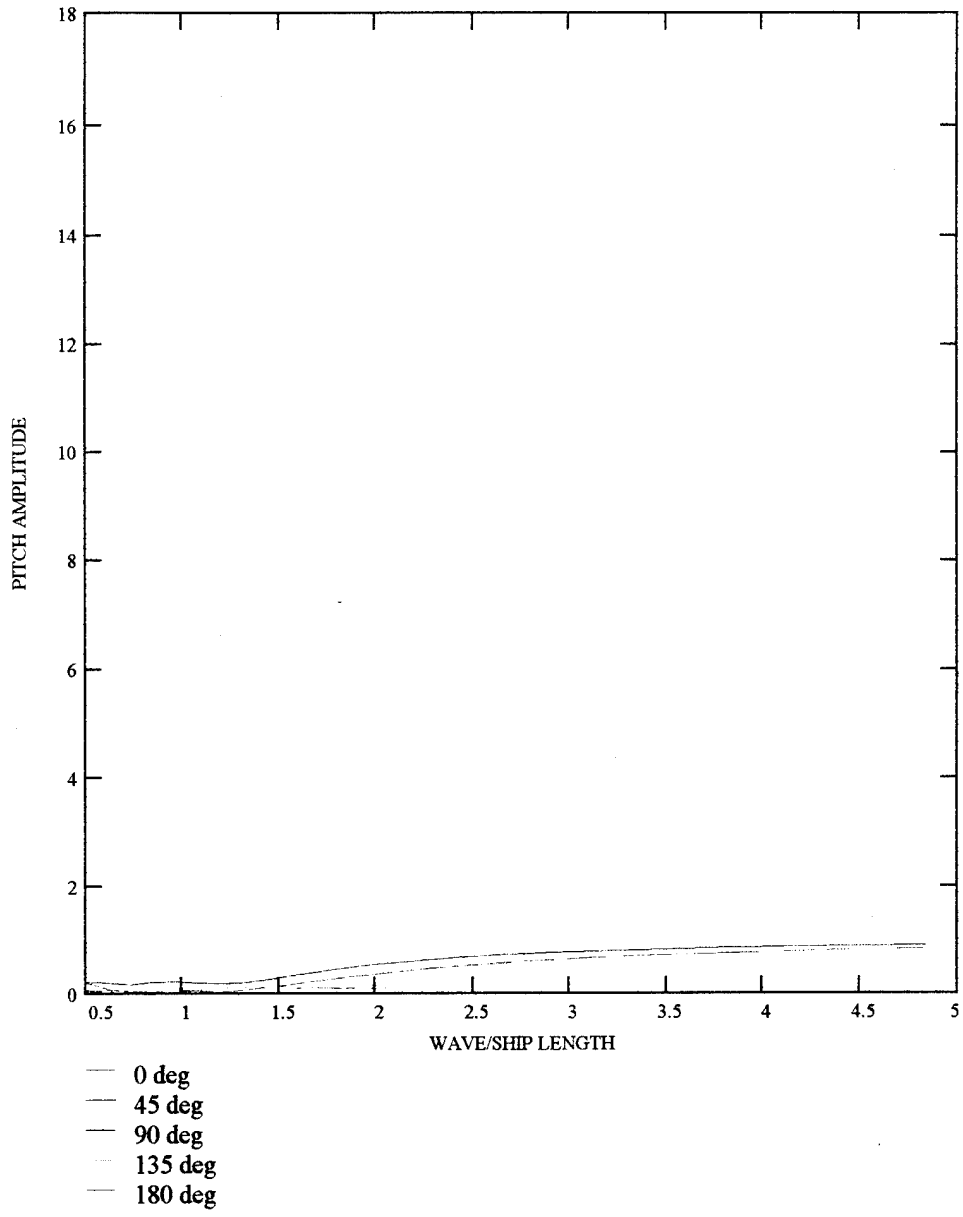

Figure 68. Speed 10 knots

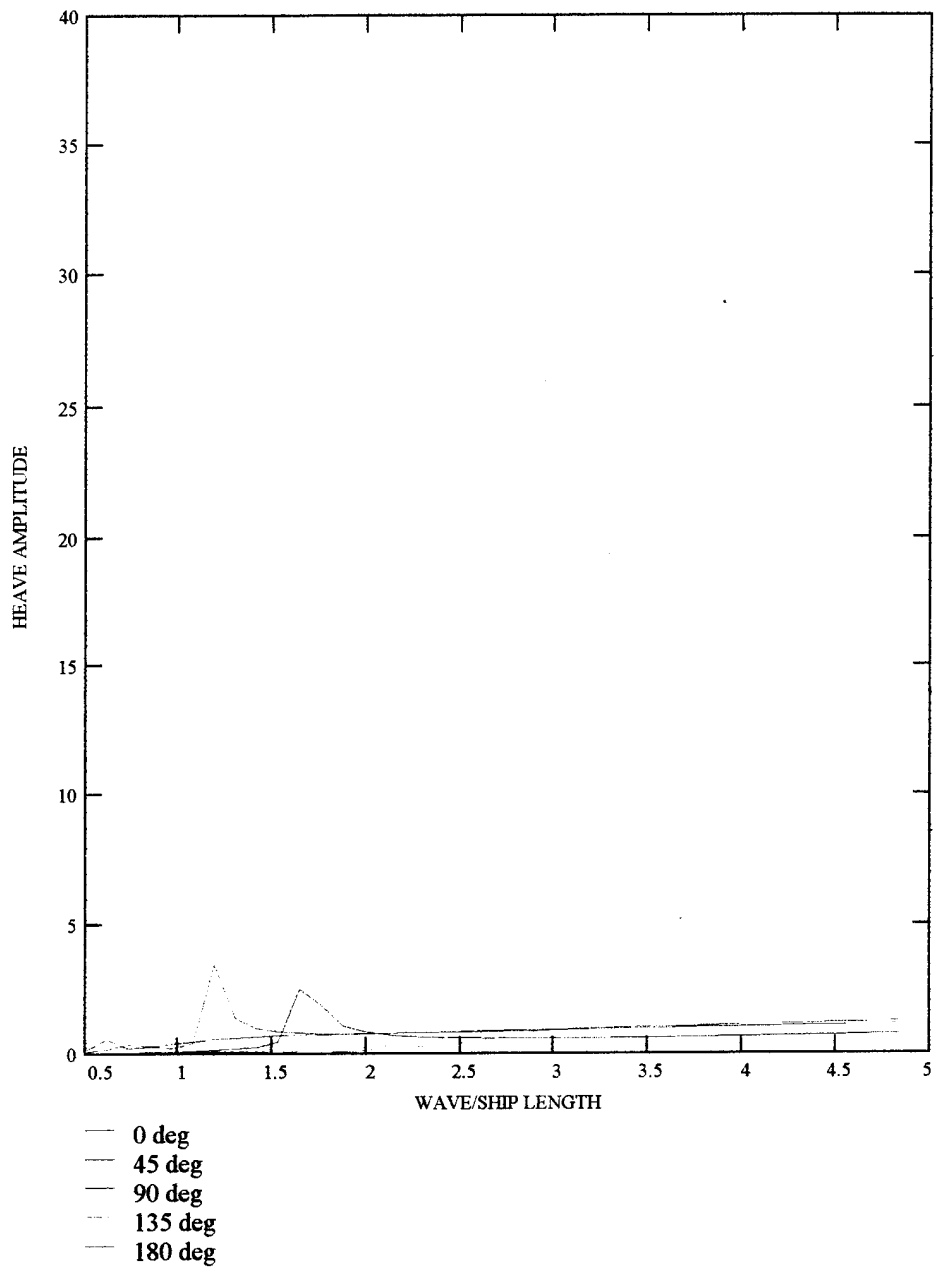

Figure 69. Speed 15 knots

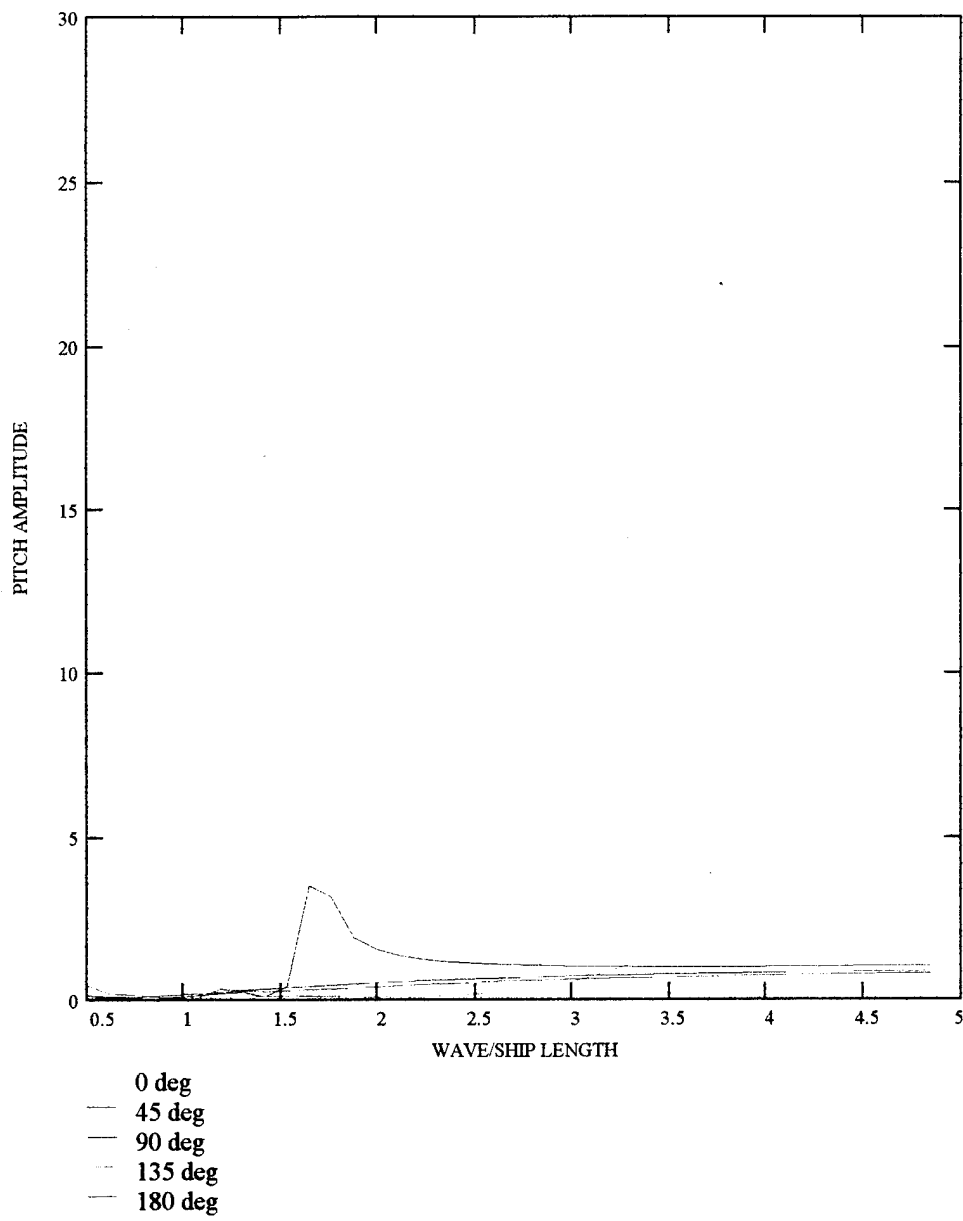

Figure 70. Speed 15 knots

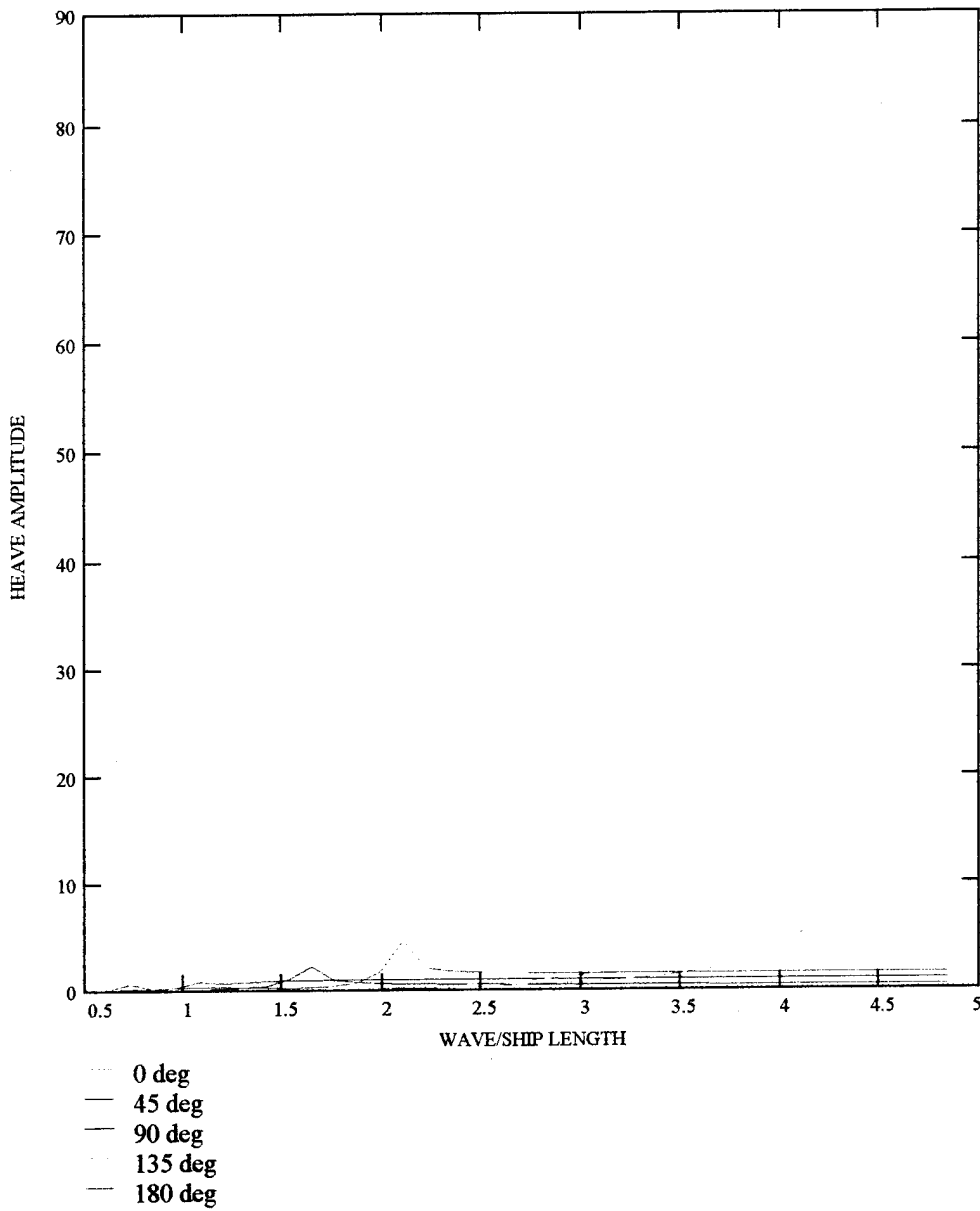

Figure 71. Speed 20 knots

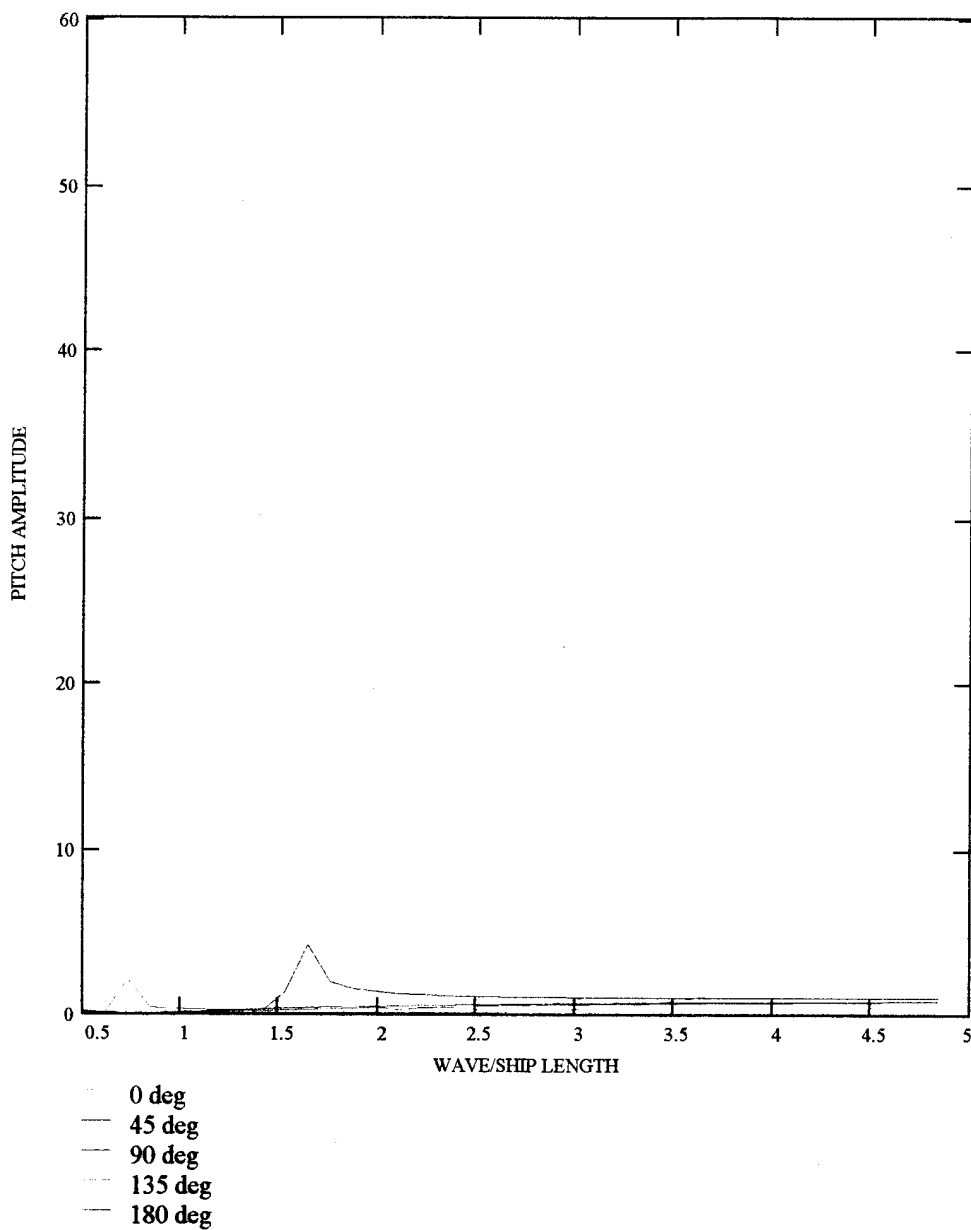

Figure 72. Speed 20 knots

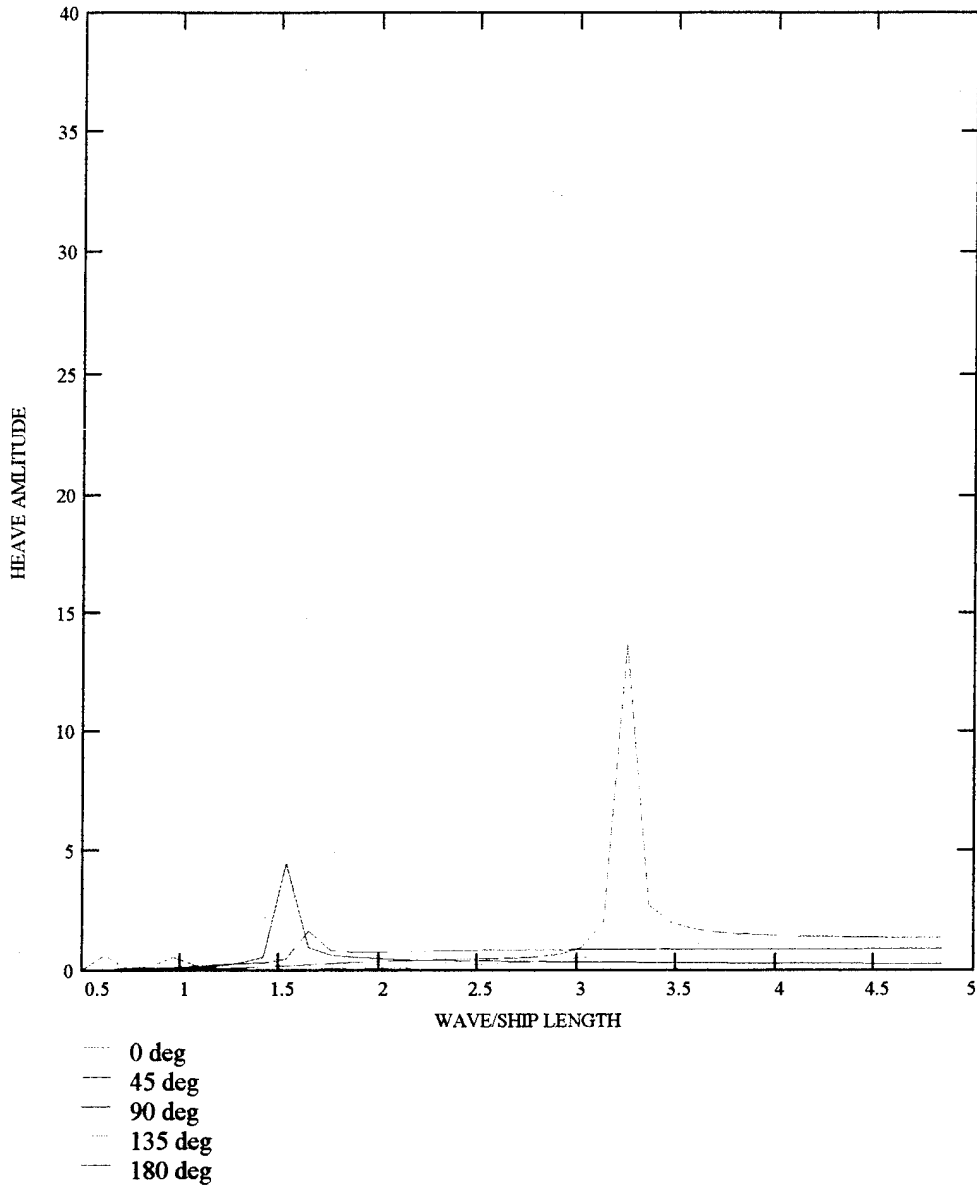

Figure 73. Speed 25 knots

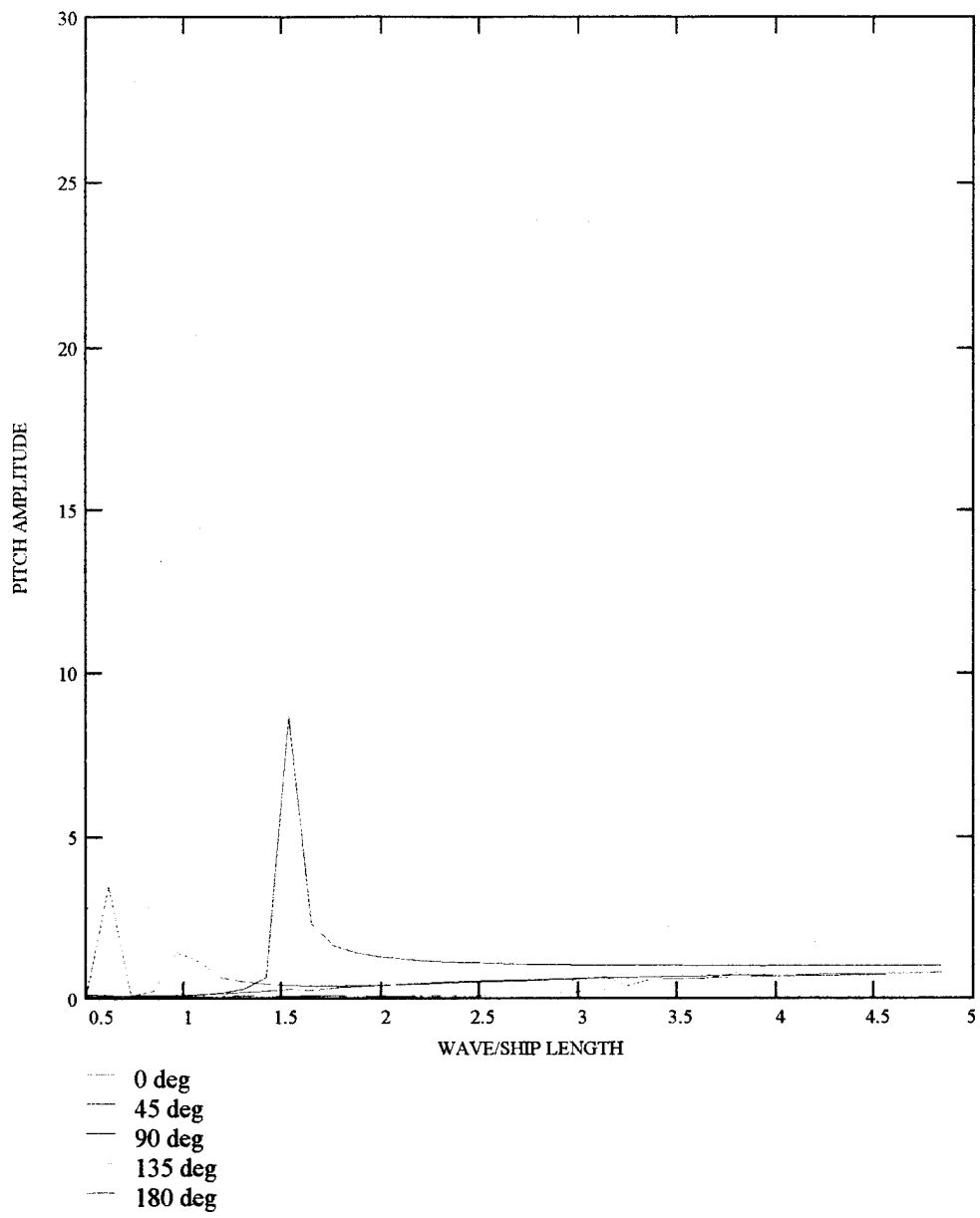

Figure 74. Speed 25 knots

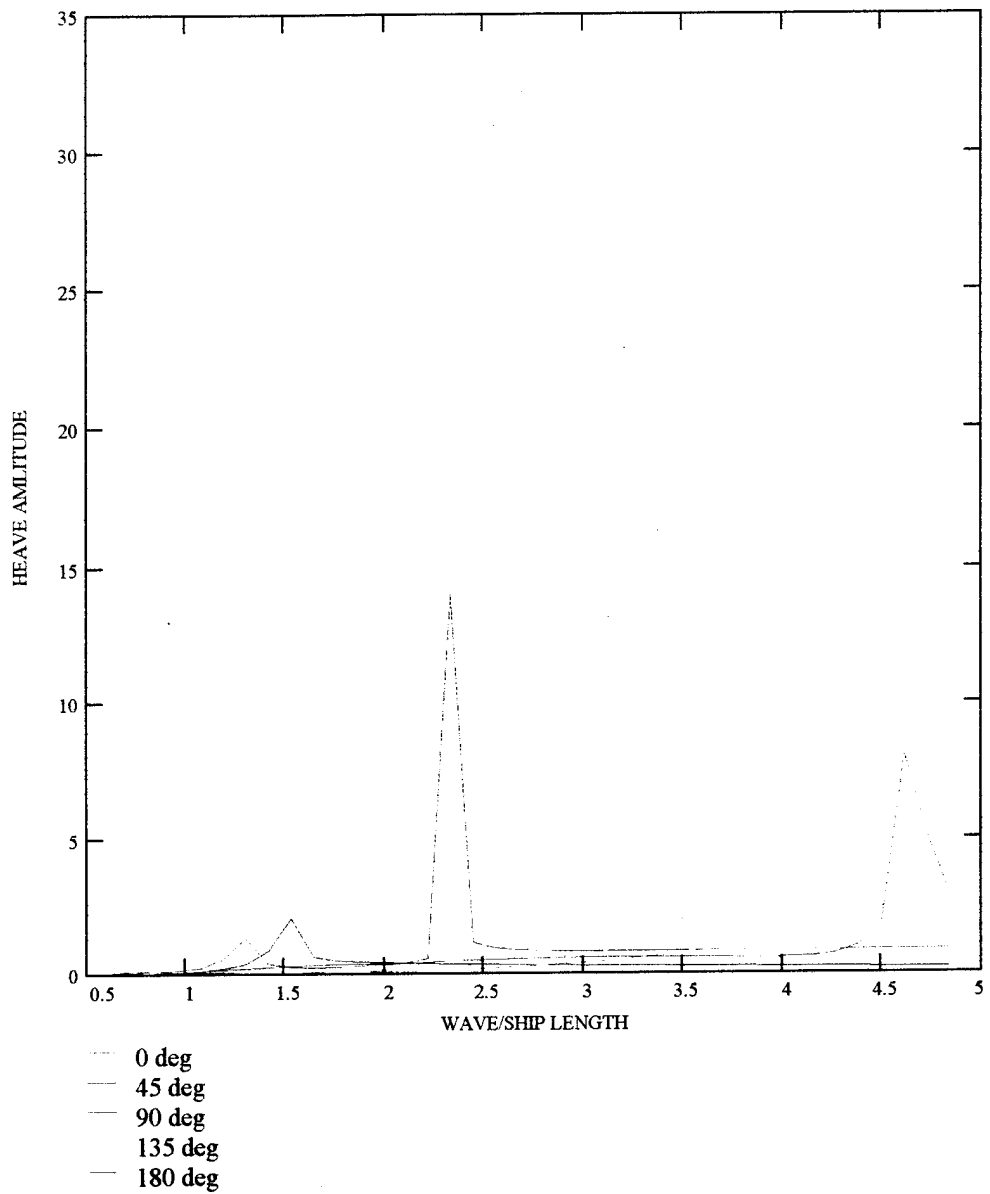

Figure 75. Speed 30 knots

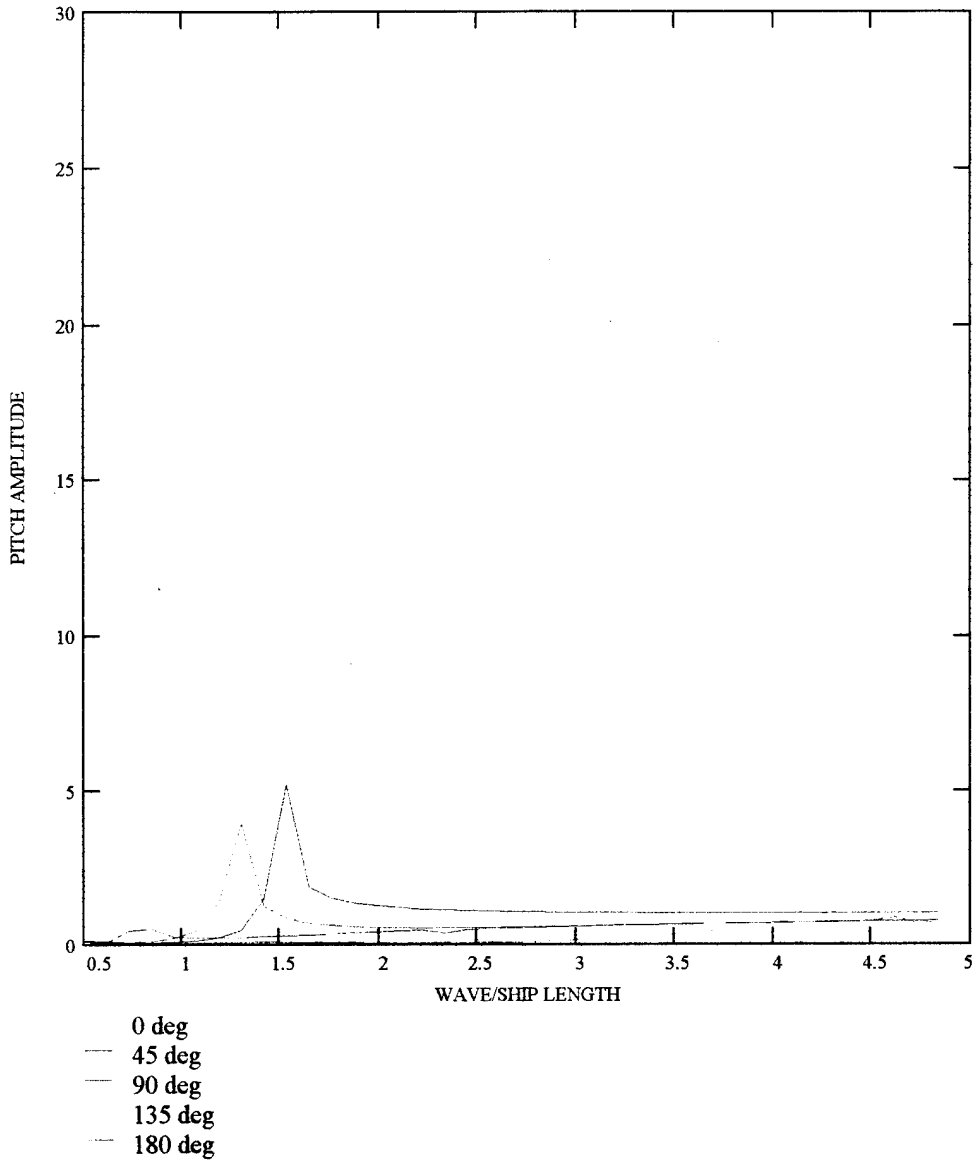

Figure 76. Speed 30 knots

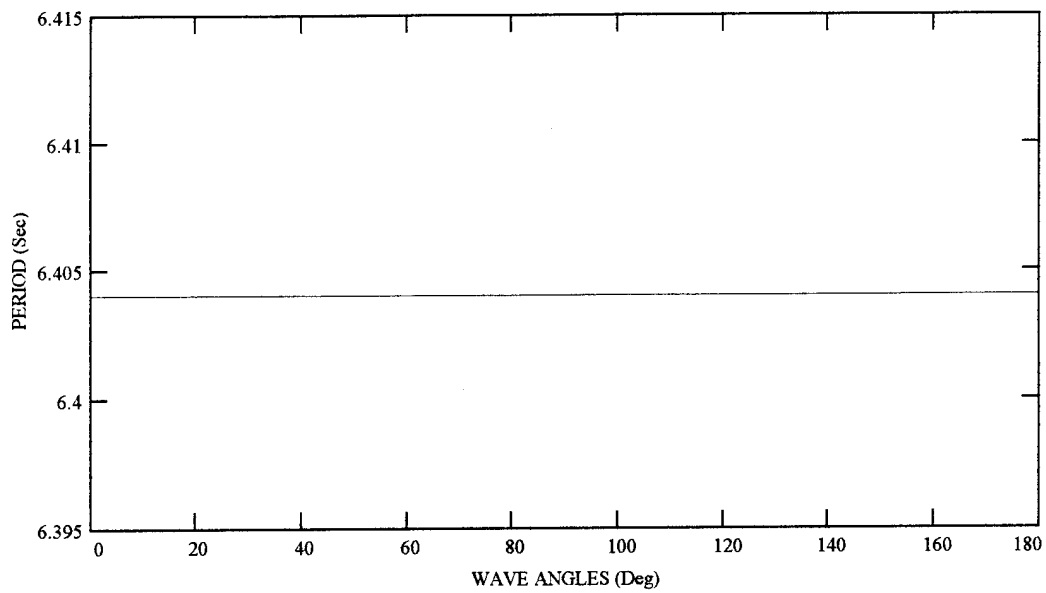

Figure 77. Pitch 0 Knots

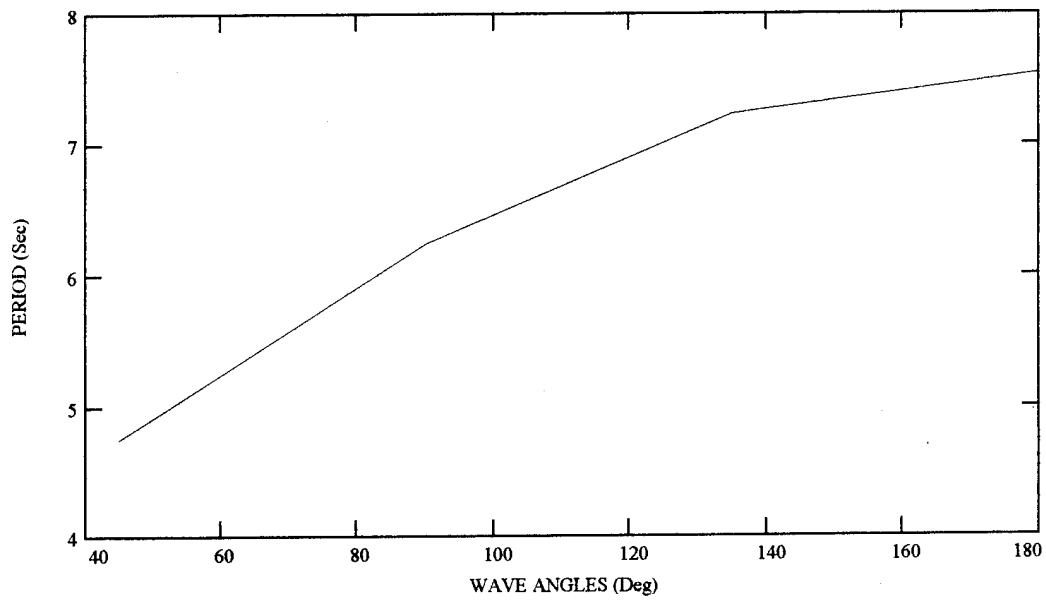

Figure 78. Pitch 5 Knots

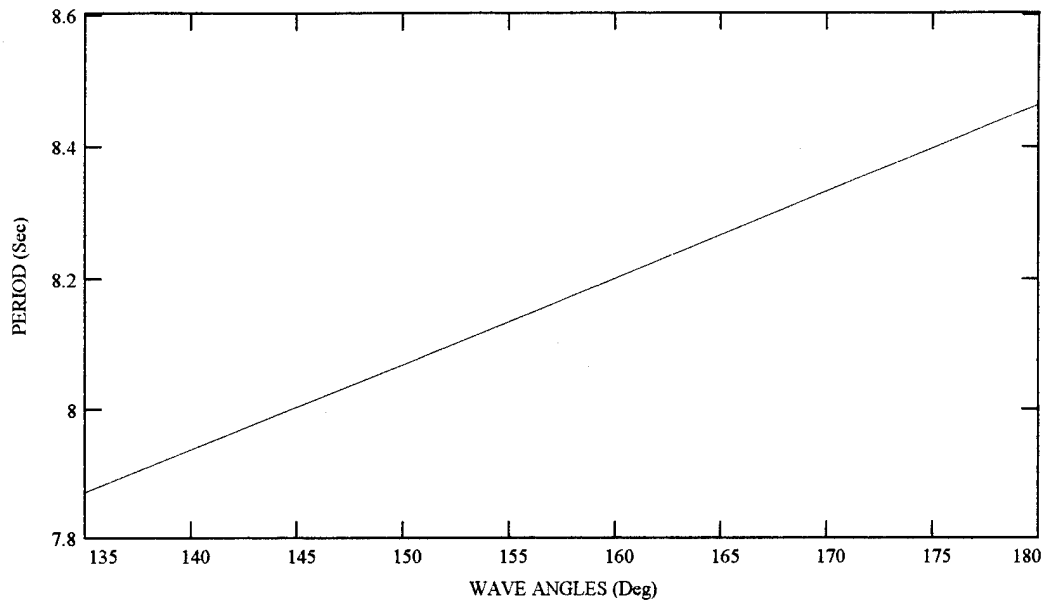

Figure 79. Pitch 10 Knots

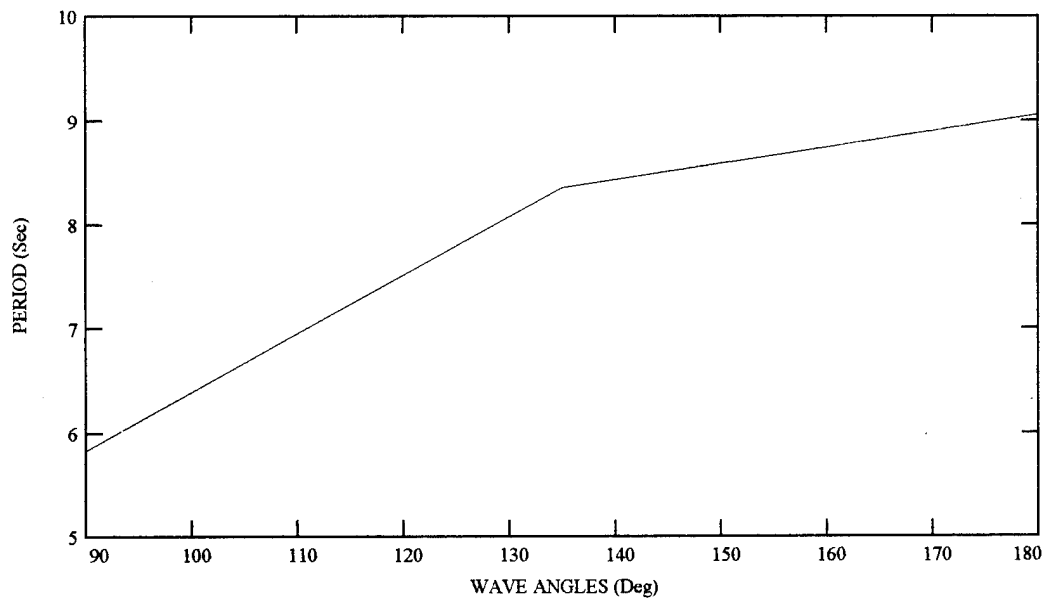

Figure 80. Pitch 15 Knots

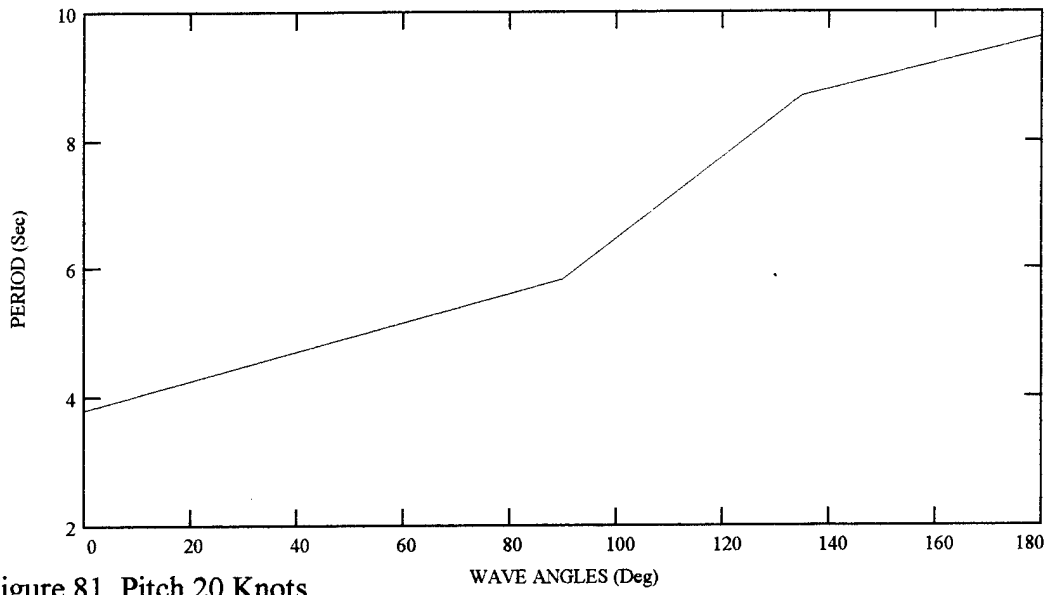

Figure 81. Pitch 20 Knots

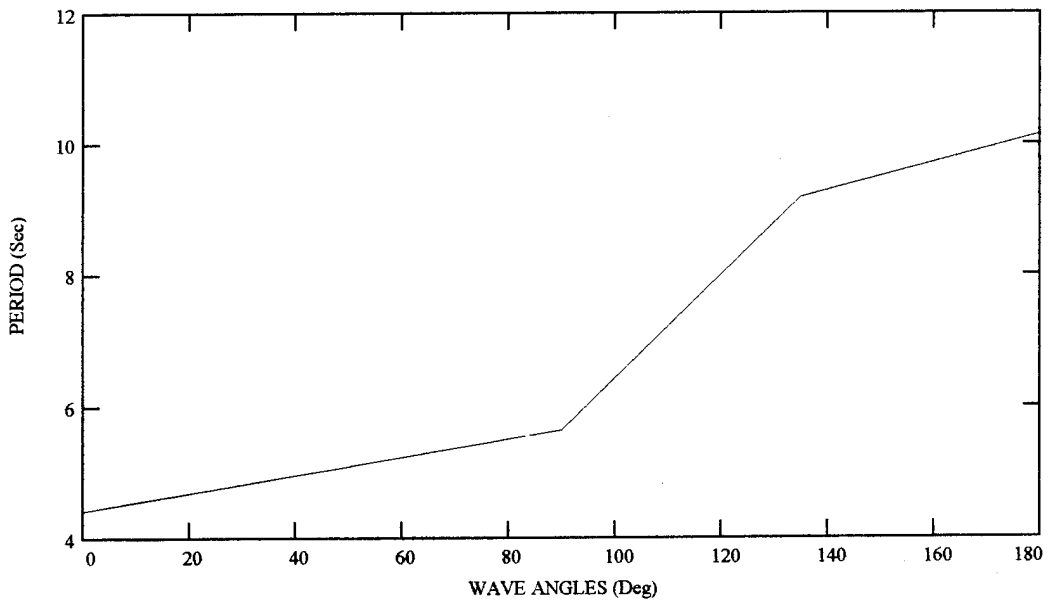

Figure 82. Pitch 25 Knots

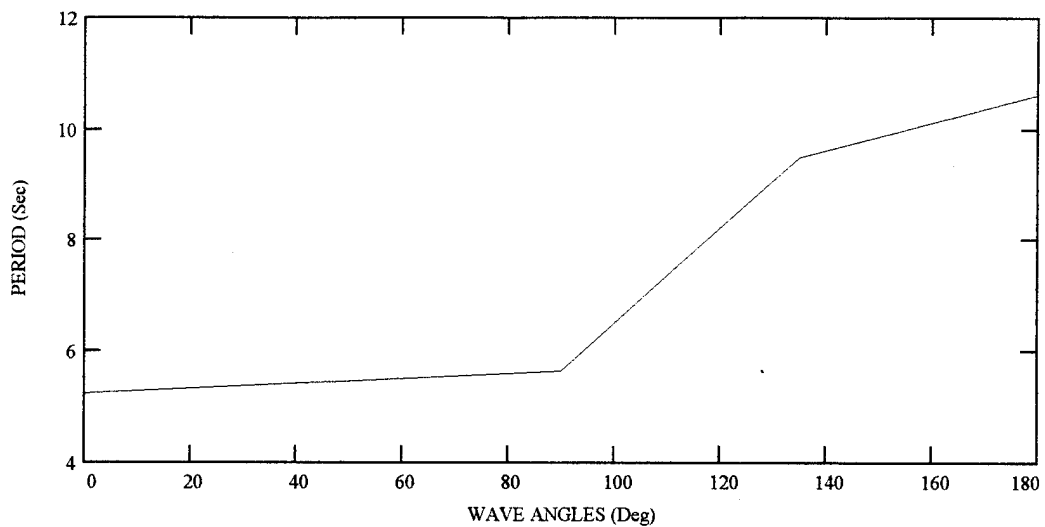
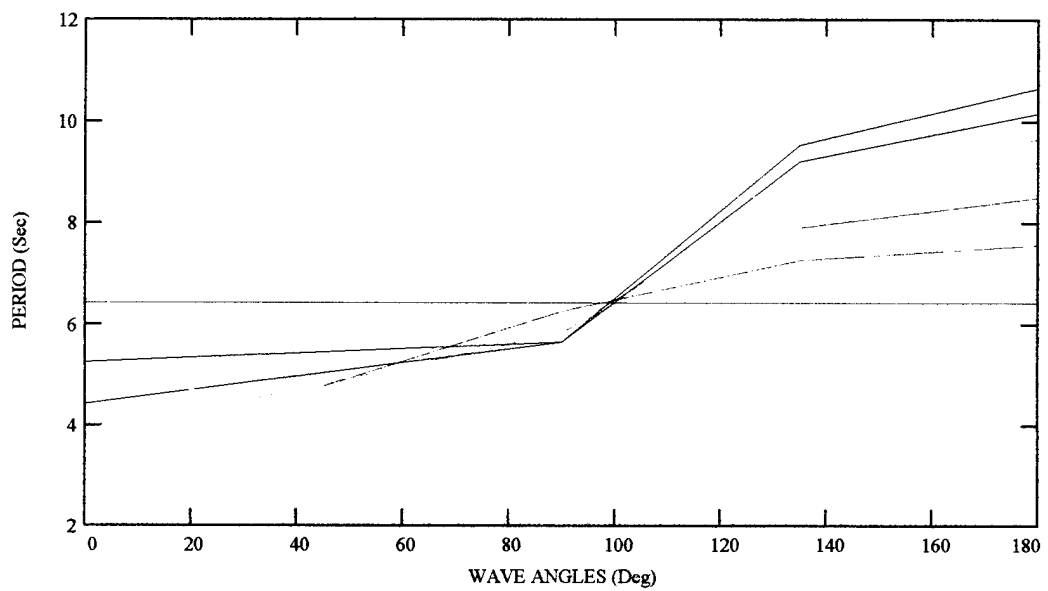

Figure 83. Pitch 30 Knots



- 0 knots
- 5 knots
- 10 knots
- 15 knots
- 20 knots
- 25 knots
- 30 knots

Figure 84. Pitch All Angles

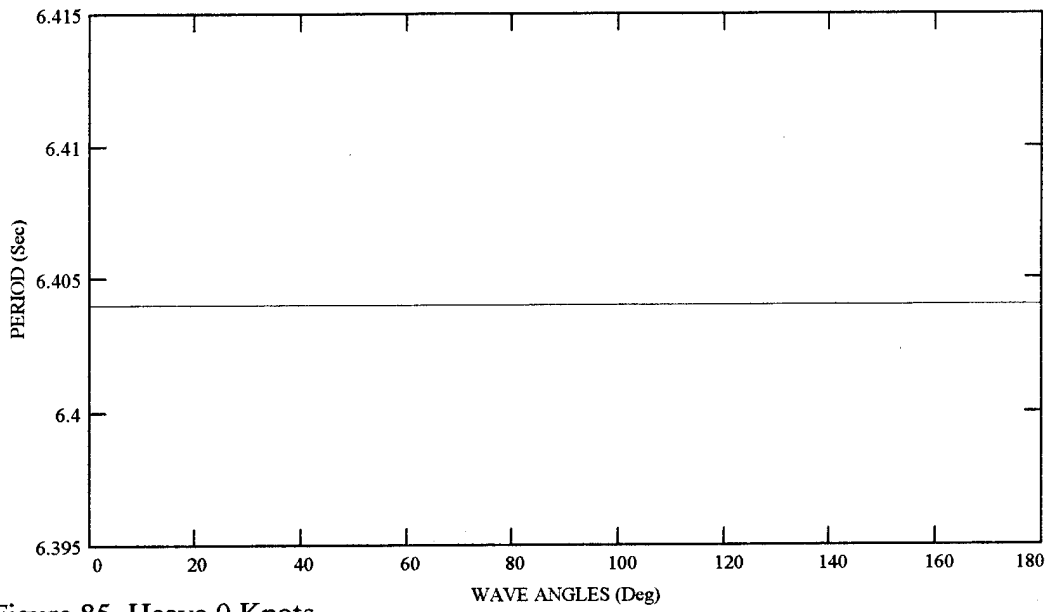

Figure 85. Heave 0 Knots

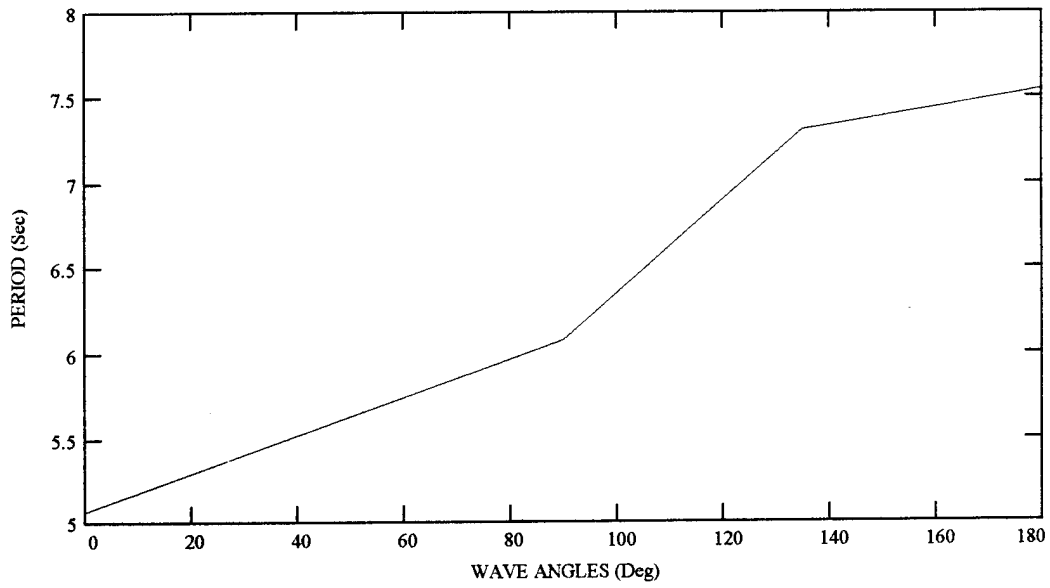

Figure 86. Heave 5 Knots

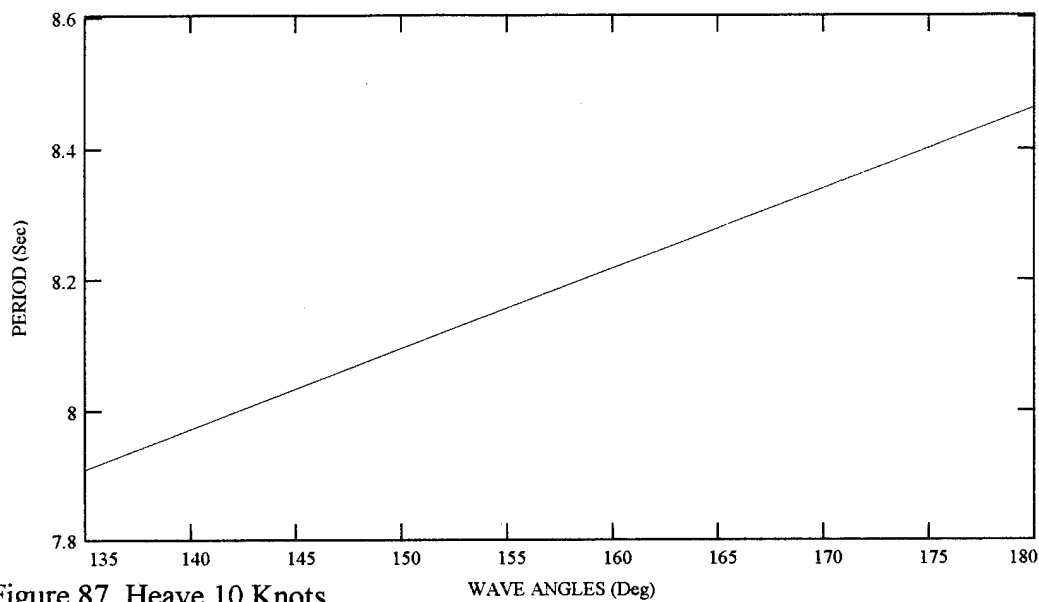

Figure 87. Heave 10 Knots

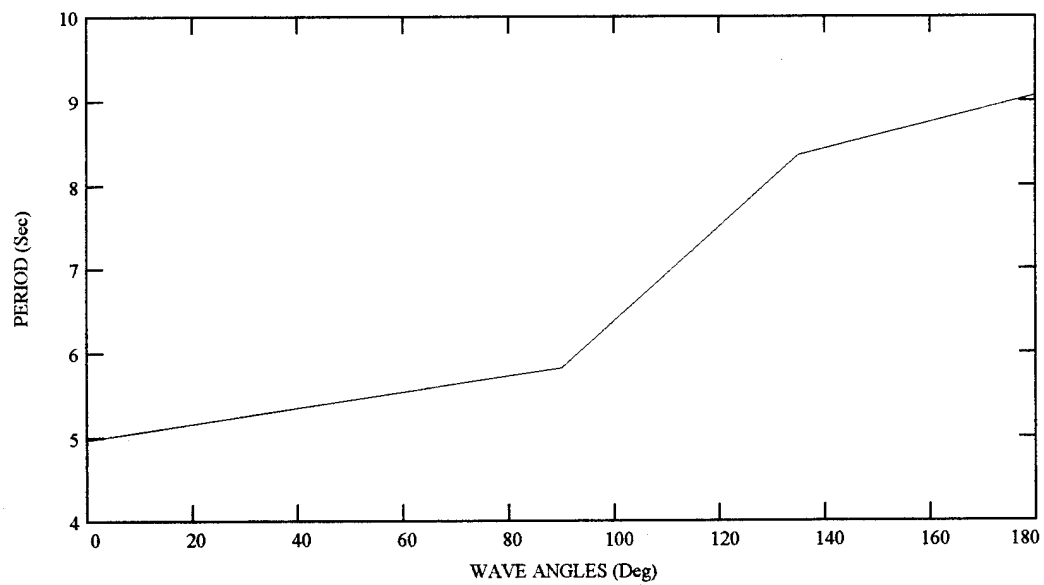

Figure 88. Heave 15 Knots

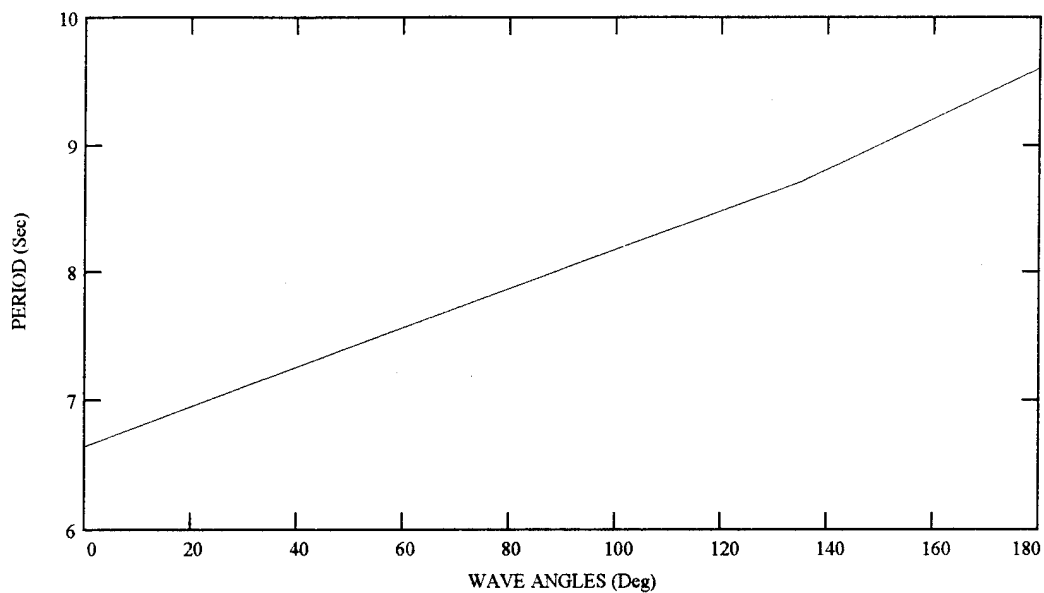

Figure 89. Heave 20 Knots

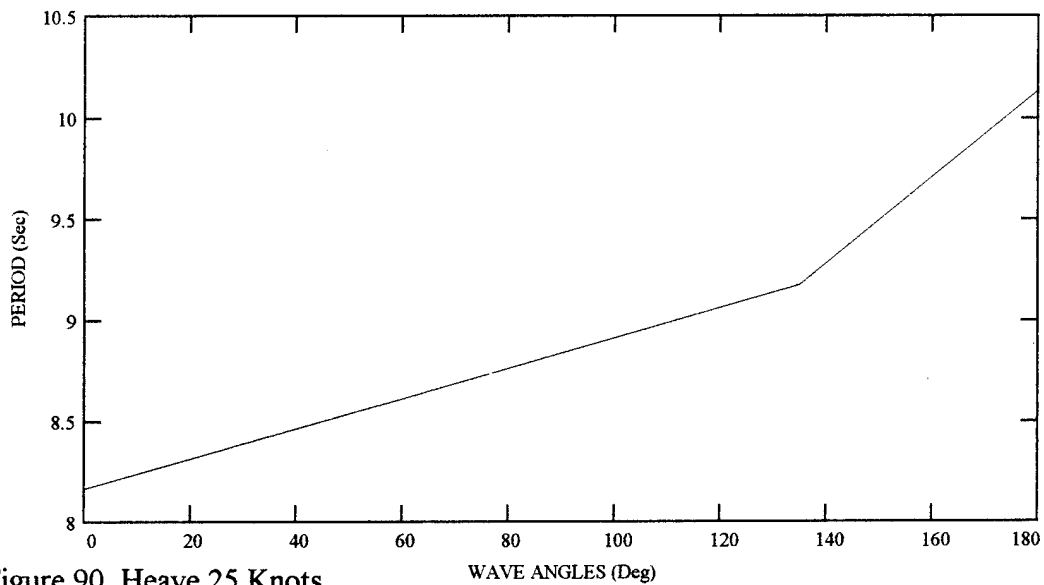

Figure 90. Heave 25 Knots

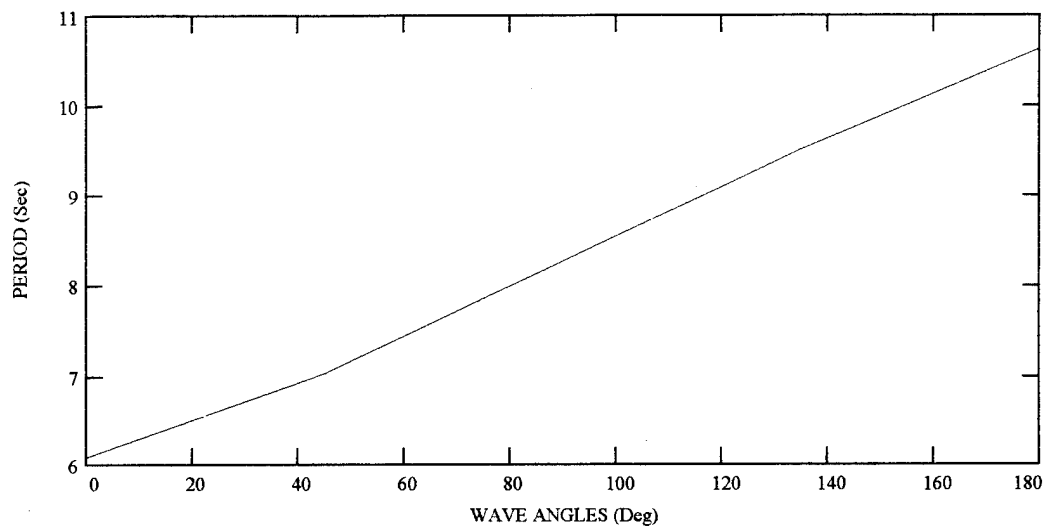
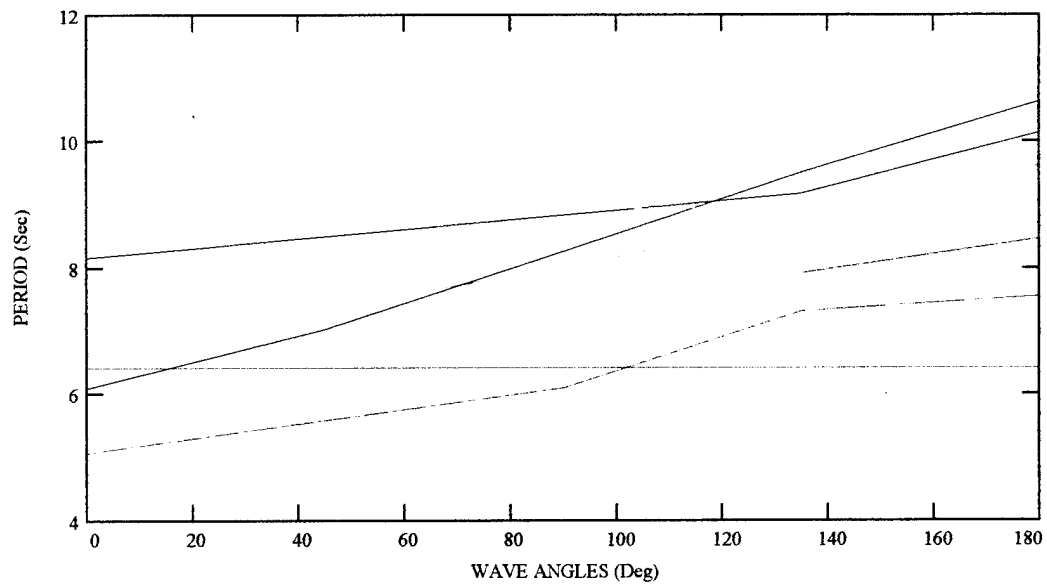

Figure 91. Heave 30 Knots



- 0 knots
- 5 knots
- 10 knots
- 15 knots
- 20 knots
- 25 knots
- 30 knots

Figure 92. Heave All Speeds



## IV. CONCLUSION AND RECOMMENDATIONS

### A. CONCLUSIONS

In trying to predict the seakeeping characteristics of the SLICE hull, it was necessary to first validate the use of the strip theory method for the SLICE hull design. The computer program used to calculate the motion data uses two-dimensional potential flow theory in solving the hydrodynamic coefficients in the equations of motion. The results for the added mass and damping coefficients for the SLICE hull were similar to similar results for the SWATH hull. The problem of resonant frequencies, which is typical for two-dimensional SWATH hydrodynamic calculations did not appear to create difficulties in the overall added mass and damping characteristics. This verified the use of the strip theory method to solve for this data. Once this method proved effective it was possible to use the other motion data that was predicted by the computer program. The heave and pitch amplitude were studied at various speeds and wave direction. It was able to locate the natural period of the waves in which resonance occurred for heave and pitch at different speeds and wave direction. It was possible to show that the period for heave increased for all speeds as the wave moved from a following wave to a head-on wave. The same trend was followed for the period in the pitch motion. As the wave direction was changed for higher speeds the period for heave increased and the period decreased for lower speeds as the wave moved from a following to a head-on wave. Again the same trend occurred for the period in the pitch motion. This information is valuable to predict motions while the ship is still in the design stages of development. It is possible to design the ship such that the natural frequency of the ship will not match the resonant frequency of the encountering waves in the environment that the ship will be designed to operate.

## **B. RECOMMENDATIONS**

In order to continue the study of the seakeeping characteristics for the SLICE hull design it will be necessary to include viscous damping into the calculations to better represent what is actually happening. Viscous damping is a large portion of the total damping of this type of hull design. It will also be necessary to incorporate some type of active controls on this hull to stabilize the vertical motion of the ship. Furthermore, yaw and sway motions must be studied along with heave and pitch.

APPENDIX

SAMPLE INPUT DATA OF SLICE HULL FOR SHIPMO.BM:

TEST DATA FOR SLICE TEST

0 0 0 0 1 0 1 0 1 0 1 0 0 19 1  
105.0000 1.9905 32.1740 1.26E-05 0.0  
30.5000 -36.0000 1.0000  
4 34.5 0.0 0  
14.3333 0.0000  
14.3333 -1.3333  
15.6667 -1.3333  
15.6667 0.0000  
13 32.5 0.0 0  
14.0000 0.0000  
14.0000 -2.3333  
14.0000 -5.2500  
13.0000 -5.7500  
12.0000 -8.0000  
13.0000 -10.3333  
15.0000 -11.0000  
17.0000 -10.3333  
18.0000 -8.0000  
17.0000 -5.7500  
16.0000 -5.2500  
16.0000 -2.3333  
16.0000 0.0000  
11 27.5 1.0 0  
13.5000 0.0000  
13.5000 -2.7500  
12.0000 -5.1250  
11.0000 -8.0000  
12.0000 -10.6667  
15.0000 -12.0000  
18.0000 -10.6667  
19.0000 -8.0000  
18.0000 -5.1250  
16.6667 -2.7500  
16.6667 0.0000  
11 22.5 1.0 0  
13.5000 0.0000  
13.5000 -2.7500  
12.0000 -5.1250

11.0000 -8.0000  
12.0000 -10.6667  
15.0000 -12.0000  
18.0000 -10.6667  
19.0000 -8.0000  
18.0000 -5.1250  
16.6667 -2.7500  
16.6667 0.0000  
11 17.5 1.0 0  
13.5000 0.0000  
13.5000 -3.2500  
12.0000 -5.3333  
11.0000 -8.0000  
12.0000 -10.7500  
15.0000 -12.0000  
18.0000 -10.7500  
18.7500 -8.0000  
18.0000 -5.3333  
16.5000 -3.2500  
16.5000 0.0000  
11 12.5 0.0 0  
14.2500 0.0000  
14.2500 -4.0000  
13.0000 -5.7500  
12.0000 -8.0000  
13.0000 -10.2500  
15.0000 -11.0000  
17.0000 -10.2500  
18.0000 -8.0000  
17.0000 -5.7500  
15.7500 -4.0000  
15.7500 0.0000  
11 8.5 0.0 1  
15.0000 -5.7500  
14.0000 -6.2500  
12.8750 -8.0000  
13.0000 -9.1250  
14.0000 -10.0000  
15.0000 -10.2500  
16.0000 -10.0000  
17.0000 -9.1250  
17.3333 -8.0000  
16.0000 -6.2500

15.0000 -5.7500  
9 5.5 0.0 1  
15.0000 -6.5000  
14.0000 -6.7500  
13.5000 -8.0000  
14.0000 -9.2500  
15.0000 -9.5000  
16.0000 -9.2500  
16.5000 -8.0000  
16.0000 -6.7500  
15.0000 -6.5000  
9 1.5 0.0 1  
15.0000 -7.2500  
14.6250 -7.5000  
14.2500 -8.0000  
14.6250 -8.5000  
15.0000 -8.7500  
15.3750 -8.5000  
15.7500 -8.0000  
15.3750 -7.5000  
15.0000 -7.2500  
4 0.0 0.0 0  
14.5000 0.0000  
14.5000 -1.0000  
15.5000 -1.0000  
15.5000 0.0000  
13 -17.5 0.0 1  
22.0000 -5.0000  
21.0000 -5.2500  
20.0000 -6.0000  
19.0000 -8.0000  
20.0000 -10.2500  
21.0000 -10.7500  
22.0000 -11.0000  
23.0000 -10.7500  
24.0000 -10.2500  
25.0000 -8.0000  
24.0000 -6.0000  
23.0000 -5.2500  
22.0000 -5.0000  
15 -19.5 0.0 0  
20.6667 0.0000  
20.6667 -3.6667

20.0000 -5.0000  
19.0000 -6.0000  
18.3333 -8.0000  
19.0000 -10.0000  
20.0000 -11.0000  
22.0000 -11.6667  
24.0000 -11.0000  
25.0000 -10.0000  
25.6667 -8.0000  
25.0000 -6.0000  
24.0000 -5.0000  
23.5000 -3.6667  
23.5000 0.0000  
11 -24.5 1.0 0  
20.5000 0.0000  
20.5000 -3.0000  
19.0000 -5.1250  
18.0000 -8.0000  
19.0000 -10.5000  
22.0000 -12.0000  
25.0000 -10.5000  
26.0000 -8.0000  
25.0000 -5.1250  
23.5000 -3.0000  
23.5000 0.0000  
11 -29.5 1.0 0  
20.5000 0.0000  
20.5000 -3.0000  
19.0000 -5.1250  
18.0000 -8.0000  
19.0000 -10.5000  
22.0000 -12.0000  
25.0000 -10.5000  
26.0000 -8.0000  
25.0000 -5.1250  
23.5000 -3.0000  
23.5000 0.0000  
11 -33.5 0.0 0  
20.6667 0.0000  
20.6667 -3.3333  
19.0000 -5.7500  
18.2500 -8.0000  
19.0000 -10.0000

22.0000 -11.5000  
25.0000 -10.0000  
25.7500 -8.0000  
25.0000 -5.7500  
23.3333 -3.3333  
23.3333 0.0000  
11 -37.5 0.0 0  
21.3333 0.0000  
21.3333 -4.0000  
20.0000 -5.5000  
19.0000 -8.0000  
20.0000 -10.2500  
22.0000 -11.0000  
24.0000 -10.2500  
25.0000 -8.0000  
24.0000 -5.5000  
23.0000 -4.0000  
23.0000 0.0000  
13 -41.5 0.0 0  
22.0000 -5.7500  
21.0000 -6.0000  
20.0000 -7.0000  
19.7500 -8.0000  
20.0000 -9.3333  
21.0000 -10.3333  
22.0000 -10.2500  
23.0000 -10.3333  
24.0000 -9.3333  
24.2500 -8.0000  
24.0000 -7.0000  
23.0000 -6.0000  
22.0000 -5.7500  
9 -44.5 0.0 1  
22.0000 -6.5000  
21.0000 -6.8750  
20.5000 -8.0000  
21.0000 -9.1250  
22.0000 -9.5000  
23.0000 -9.1250  
23.6667 -8.0000  
23.0000 -6.8750  
22.0000 -6.5000  
9 -48.5 0.0 1

22.0000 -7.3333  
21.6667 -7.6667  
21.3333 -8.0000  
21.6667 -8.3333  
22.0000 -8.6667  
22.3333 -8.3333  
22.6667 -8.0000  
22.3333 -7.6667  
22.0000 -7.3333  
-3.0000 0.0000  
9999.0 0.0 0.0  
7 1.5 15.0 -8.0  
1.0000 52.5000 525.0000 12.0000 0.0000 50.0000 8.3333  
0.8500  
0.0000 180.0000 45.0000  
0.0

## REFERENCES

- Beck, R. F. and Troesch, A. W., "Documentation and User's Manual for the Computer Program SHIPMO.BM," Report No. 89-2, 1989.
- Fein, J. A., Ochi, M. D., and McCreight, K. K., "The Seakeeping Characteristics of a Small Waterplane Area, Twin-Hull (SWATH) Ship," 13th Symposium of Hydrodynamics, 1987.
- Lee, C. M., "Theoretical prediction of Motion of Small Waterplane Area Twin-Hull (SWATH) Ships in Waves," David W. Taylor Naval Ship Research and Development Center, Report 760046, 1976.
- Lee, C. M. and Curphey, R. M., "Prediction of Motion, Stability, and Wave Load of Small-Waterplane-Area, Twin-Hull Ships," SNAME Transactions, vol. 85, pp. 94-130, 1977.
- McCreight, K. K., "Assessing the Seaworthiness of SWATH Ships," SNAME Transactions, vol. 95, pp. 189-214, 1987.
- Papoulias, F. A., "Dynamics of Marine Vehicles," Informal Lecture Notes for ME 4823, Naval Postgraduate School, Monterey, California, Summer 1993.



## INITIAL DISTRIBUTION LIST

	No. Copies
1. Defense Technical Information Center Cameron Station Alexandria, VA 22304-6145	2
2. Dudley Knox Library, Code 52 Naval Postgraduate School Monterey, CA 93943-5101	2
3. Chairman, Code ME Department of Mechanical Engineering Naval Postgraduate School Monterey, CA 93943-5000	1
4. Professor Fotis A. Papoulias, Code ME/PA Department of Mechanical Engineering Naval Postgraduate School Monterey, CA 93943-5000	6
5. Naval Engineering Curricular Office, Code 34 Naval Postgraduate School Monterey, CA 93943-5100	1
6. Stephen Peffers 1056 Halsey Dr. Monterey, CA 93940	2