

C & C TECHNOLOGIES, INC.

A TECHNICAL REPORT

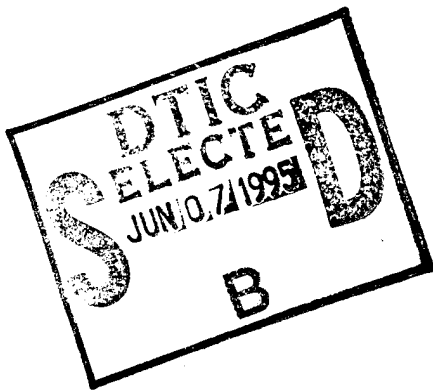

on

CR 7410-95-0024

SEA LION TELEMETRY SYSTEMS ANALYSIS

for

NRL CONTRACT N00014-94-P-6601

19950605 101

MARCH 28, 1994

DTIC QUALITY INSPECTED 3

Approved for public release;
Distribution is unlimited.

SEA LION TELEMETRY SYSTEMS ANALYSIS

GENERAL

In support of the Naval Research Laboratory's Sea Lion program to instrument the remotely operated vehicles with multibeam bathymetry and imagery systems, it is necessary to demonstrate a telemetry system capable of handling the high data rates characteristic of this sensor suite at ranges of several miles on moving platforms. The telemetry system will have the capacity to deliver data at very high rates (possibly up to 8 megabits per second). Such a system will facilitate the relay of bathymetric data from the Sea Lions to a mother ship.

SPECIFIC

Task 2 of Contract N00014-94-P-6601 states "The contractor shall research and determine what telemetry systems are commercially available with regard to high data rate telemetry systems, their specifications, leadtimes, and costs. The commercial systems shall be ranked from the compiled information. Factors for consideration are: (1) data rates; (2) transmission methods; (3) software compatibility; (4) hardware configuration; (5) anticipated reliability; and, (6) cost." This report will outline the results of our investigation of the commercial availability of telemetry systems capable of meeting the technical requirements of the Sea Lion project..

Criteria searched:

- 1) Data rate
- 2) Transmission method
- 3) Software Compatibility
- 4) Hardware configuration
- 5) Anticipated reliability
- 6) Cost
- 7) Lead time
- 8) Availability of evaluation units

Two types of transmission systems were identified and investigated, narrow band and spread spectrum systems. A desk top comparison was made between the two types of systems to determine which technology best suits the Sea Lion project requirements. A summary follows:

Narrow-band with space diversity combination reception.

- 1) Up to 10 Mbits/sec.
- 2) Narrow-band FSK modulated microwave carrier utilizing space diversity reception.
- 3) Compatible with most LAN transmission formats utilizing a bridge interface.
- 4) Numerous discrete components, more cabling and space required.

Distribution/	
Availability Codes	
Dist	Avail. and/or Special
A-1	

- 5) Anticipate more maintenance due to number of components in system, with less link reliability.
- 6) Over \$100,000.
- 7) Quoted 180 days to gather all components in system.
- 8) Not readily available off the shelf.

Spread Spectrum.

- 1) 256 Kbits/sec minimum, up to 2Mbits utilizing compression.
- 2) Spread spectrum, direct sequence spreading modulation.
- 3) Compatible with most LAN transmission formats utilizing a bridge interface.
- 4) Fewer components, greater system integration, less cabling and space required..
- 5) Anticipate less physical maintenance with greater link reliability.
- 6) Under \$30,000.
- 7) Normally only the time required to ship from the factory.
- 8) Available off the shelf, determined by manufacturers willingness to participate.

Representative narrow band telemetry system price and component breakdown as quoted from Broadcast Microwave Services, Inc.

Narrow-band telemetry system with space diversity combination receiver, Sea Lion mobile terminal.

Quantity	Item	Unit price	Total price
1	6 db Omni Antenna	\$ 2,650.00	\$ 2,650.00
1	Antenna diplexer and circulator assembly	\$ 4,450.00	\$ 4,450.00
1	Command Receiver, L band	\$14,800.00	\$14,800.00
1	Video / Data Transmitter, L band, 10 watts	\$12,700.00	\$12,700.00
1	Pre-modulation filter assembly	\$ 3,950.00	\$ 3,950.00
2	PCM / FSK encoder / decoder	\$ 1,950.00	\$ 3,900.00
2	Frame / packet bit synchronizer	\$ 2,600.00	\$ 5,200.00
1	Translation Bridge	\$ 4,200.00	\$ 4,200.00
			Total: \$51,850.00

Shipboard control terminal

Quantity	Item	Unit price	Total price
2	6 db Omni Antenna	\$ 2,650.00	\$ 5,300.00
2	Antenna diplexer and circulator assembly	\$ 4,450.00	\$ 8,900.00
2	Command Receiver, L band	\$14,800.00	\$29,600.00
1	Video / Data Transmitter, L band, 10 watts	\$12,700.00	\$12,700.00
1	1200 MRC diversity combiner	\$26,127.00	\$26,127.00

1	Pre-modulation filter assembly	\$ 3,950.00	\$ 3,950.00
2	PCM / FSK encoder / decoder	\$ 1,950.00	\$ 3,900.00
2	Frame / packet, bit synchronizer	\$ 2,600.00	\$ 5,200.00
1	Translation Bridge	\$ 4,200.00	\$ 4,200.00
			Total: \$99,877.00

Overall narrow-band telemetry system total price: \$151,727.00

Representative spread spectrum telemetry system price and component breakdown as quoted from Cylink.

Quantity	Item	Unit Price	Total Price
2	Airlink 256 Digital Spread Spectrum Radio	\$3,195.00	\$6,390.00
2	Gandalf Bridge with Optimizer Software	\$2,100.00	\$4,200.00
2	Antennas, Omni, 860-940 Mhz.	\$ 866.00	\$1,732.00
			Overall Total: \$12,322.00

NARROW BAND

Ayden Vector / Walt Schelmet
 Loral Conic / Al Hackstaff
 Berg Systems / Pete Kelly
 AP Labs / Rich Grohal
 Microdyne / Dwight Turner

California Microwave / Jerry Vettrus
 Emhiser Research, Inc./ Jay Lawson
 Militech Corp/ Dean Dixon
 BMS/ R. B. Anderson

SPREAD SPECTRUM

Digital Radio Corp / Arvin Perry
 Proxim Inc / Tom Mitchels
 Cylink / Mickey Marks
 Western Multiplex Corp. / Harold Rhodes
 Aironet / Tim Clark

Solectek Corp / Dean Fledderjohn
 Harris Corp / Byron Knight

These criteria and telemetry systems were discussed in a meeting between C & C Technologies and NRL personnel. Spread spectrum technology was determined to be best suited for the Sea Lion Project based on the criteria noted above and that spread spectrum systems investigated do not require an FCC license. Narrow band systems do require an FCC license. Mr. Harris and his staff at NRL determined that the requirement for a license would cause unacceptable delays in the Sea Lion project in that the process takes in excess of 180 days.

SPREAD SPECTRUM TELEMETRY SYSTEMS WERE RANKED AS FOLLOWS:

System price and component breakdown as quoted from *Cylink*.

Quantity	Item	Unit Price	Total Price
2	Airlink 256 Digital Spread Spectrum Radio	\$3,195.00	\$6,390.00
2	Gandalf Bridge with Optimizer Software	\$2,100.00	\$4,200.00
2	Antennas, Omni, 860-940 Mhz.	\$ 866.00	\$1,732.00
	Overall Total:		\$12,322.00

Specifications

Cylink Airlink 256

Data rate:	Raw data transfer rate of 256 thousand bits / second
Frequency:	902-928 Megahertz. (L band)
Power output:	1 Watt transmitter power
System (spreading) gain:	119 db
Effective range:	Measured out to 3.0 miles
Physical size:	2.125" high x 8.5" wide x 10.5" length
Weight:	8.5 pounds
System hardware:	Radio, bridge, antenna, coax cable and interconnect wiring
Power requirements:	120 VAC
Power consumption:	20 watts

System price and component breakdown as quoted from *Aironet*.

Quantity	Item	Unit Price	Total Price
2	Arlan 620 Ethernet Bridges	\$2,495.00	\$4,990.00
2	Antennas, Omni, 860-940 Mhz	\$ 866.00	\$1,732.00
	Overall Total		\$6,722.00

Specifications

Solectek Airlan

Data rate:	Raw data transfer rate of 2 Million bits / second
Frequency:	902-928 Megahertz (L band)
Power output:	250 Milliwatts
System (spreading) gain:	na
Effective range:	untested, predicted to be 1.5 miles
Physical size:	3.4" high x 13.0" wide x 15.7" length
Weight:	14 pounds

System hardware: Radio, Antenna, Coax and interconnecting wiring
 Power requirements: 120 VAC
 Power consumption: 73 watts

System price and component breakdown as quoted from *Solectek*.

Quantity	Item	Unit Price	Total Price
2	AIRLAN/BRIDGE	\$4,999.00	\$9,998.00
2	3ft antenna cable and connectors	\$ 49.00	\$ 98.00
2	Antennas, Omni, 860-940 Mhz	\$ 866.00	\$1,732.00
		Overall Total	\$11,828.00

Specifications

Aironet Arlan 620

Data rate: Up to 1.35 Million bits / second
 Frequency: 902-928 Megahertz (L band)
 Power output: 1 Watt transmitter power
 System (spreading) gain: N/A
 Effective range: predicted to be up to 3 miles
 Physical size: 1.9" high x 9.6" wide x 9.6" length
 Weight: 3 pounds
 System hardware: Radio, Coax cable, antenna, various interconnect cables
 Power requirements: 125 volts AC
 Power consumption: N/A

Copies of the systems specification sheets for telemetry systems that were investigated are attached. Many of the systems investigated were eliminated from testing due to cost, power output (expected range), data rate or availability.

ATTACHMENTS:

- a. AIRONET, AIRLAN 620 specifications sheet.
- b. CYLINK, AirLink, specifications sheet.
- c. SOLECTEK, AIRLAN/Bridge Unit, specifications sheet.
- d. WESTERN MULTIPLEX CORPORATION, Lynx, specifications sheet.
- e. Proxim, Inc., RangeLAN2/Bridge, specifications sheet.
- f. Persoft, Inc., INTERSECT REMOTE BRIDGE. specifications sheet.
- g. BROADCAST MICROWAVE SERVICES. Inc., specifications sheets.
- h. LORAL Instrumentation, specifications sheets.
- i. EMHISER RESEARCH, Inc., specifications sheets.
- j. Microdyne, specification sheets.

ARLAN 620 FEATURES AND SPECIFICATIONS

SPECIFICATIONS	ARLAN 620	ARLAN 620E	SPECIFICATIONS	ARLAN 620	ARLAN 620E
SIZE/WEIGHT			ANTENNAS		
Length:	9.6" (24.4 cm)	9.6" (24.4 cm)	Detachable Dipole standard	8" (20.3 cm)	7" (17.8 cm)
Width:	9.6" (24.4 cm)	9.6" (24.4 cm)	Remote optional	Omnidirectional whip	Desktop dipole
Height:	1.9" (4.8 cm)	1.9" (4.8 cm)	Directional optional	Yagi	
Weight:	3 lb. (1.4 kg)	3 lb. (1.4 kg)	RANGE		
POWER			Indoor dense office	300' (91 m)	150' (45.7 m)
Ext. Power Supply	125 VAC	240 VAC	Indoor open office	600' (183 m)	300' (91.4 m)
DC input terminal	Standard	Standard	Open factory/warehouse	3000' (914 m)	1500' (457.2 m)
RADIO			Outdoor line-of-sight	6 miles (9.7 km)	3 miles (4.8 km)
Radio Frequency	902 - 928 MHz	2.460 GHz	LAN INTERFACE		
Number of Channels	12 selectable	7 selectable	Protocol independent	Standard	Standard
Data Transfer Rate	Up to 1.35M bps	230K bps to 1M bps	IEEE 802.3 & Ethernet	Standard	Standard
Transmit Power	1W max.	100mW max.	10Base2 (thin) via BNC T	Standard	Standard
Certification	FCC and DOC	DTI MPT 1349	10Base5 (thick) via DB-15 AUI	Standard	Standard

ENVIRONMENTAL CHARACTERISTICS: Operating Temp. 32°F to 104°F [0°C to 40°C]

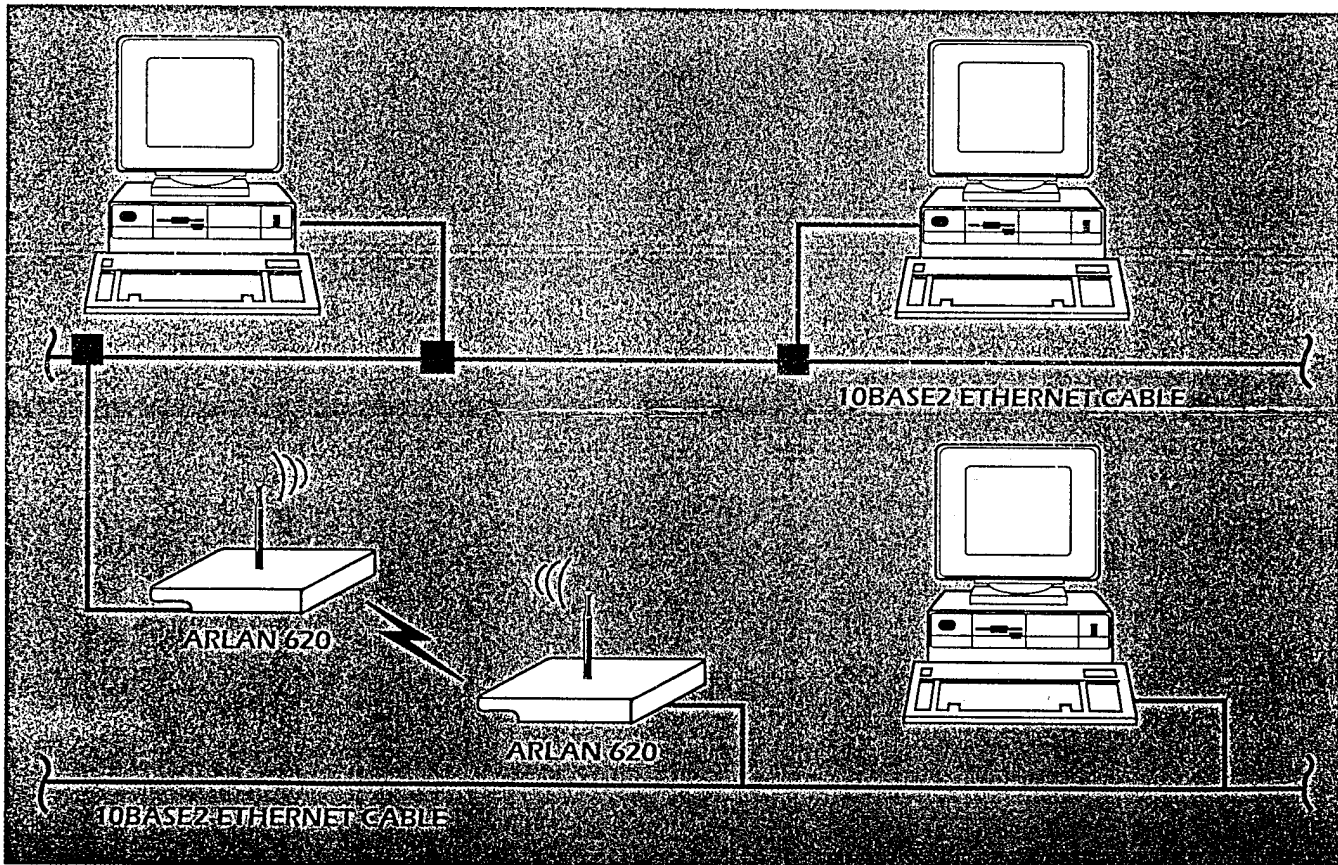

AIRONET Wireless Communications, Inc. / P.O. Box 5292, Akron, Ohio 44334-0292 / 216-873-2000 / 800-800-8016

AirLink Specifications

Model	Data Rate	Interface	Order Number
AirLink VF	Analog voice	2 wire	12999-010
AirLink 64	64 kb/s sync or 19.2 kb/s async	V.11	12842-010
		RS-232	12482-110
		EIA-530	12482-210
AirLink 128	128 kb/s sync or 38.4 kb/s async	V.11	12482-020
		RS-232	12482-120
		EIA-530	12482-220
AirLink 256	256 kb/s sync	V.11	12482-030
		EIA-530	12482-230

General

- Operating Frequency 902 - 928 MHz
- Modulation Type Spread Spectrum: BPSK
- Spreading Code Direct Sequence
- System Gain

AirLink VF	128 dB
AirLink 64	125 dB
AirLink 128	122 dB
AirLink 256	119 dB
- RF Connector TNC
- Antenna 6" Omni-directional (opt.)
24" Directional Yagi (opt.)

User Interface

- Front Panel LED: Radio link ok/down
Power on/off
- Rear Panel BNC connector for
burst synchronization
Switch panel for
configuration

Connector Interface

- Connector

RJ11: 2 wire (VF only)
V.11: 34 pin Winchester female
RS-232: DB25 female
EIA-530: DB25 female

Specifications subject to change without notice

Cylink is a registered trademark and AirLink is a trademark of Cylink Corporation.

The performance specifications are for optimum conditions and may be affected by location, environment, and other operating considerations.

Transmitter Specifications

- Maximum Power Output 28 dBm
- Frequency Stability 10 ppm
- Frequency Source Synthesized
- Bandwidth

AirLink VF	2.5 MHz
AirLink 64	5.0 MHz
AirLink 128	10 MHz
AirLink 256	20 MHz

Receiver Specifications

- Unfaded BER <10⁻¹⁰
- Sensitivity

AirLink VF	-100 dBm
AirLink 64	-97 dBm
AirLink 128	-94 dBm
AirLink 256	-91 dBm

Electrical/Mechanical

- Power Requirements 110 or 220 VAC, external power supply
- Power Consumption 20w
- Dimensions 2.125"H x 8.5"W x 10.5"L
(55 mmH x 215 mmW x 265 mmL)
- Weight 8.5 lbs (3.85 kg)

FCC Certification

- FCC Part 15 certified
- FCC identifier: G83AirLink
- Equipment class: spread spectrum transmitter



Cylink Limited U.K.
Tel: +44-256-468186
Fax: +44-256-24156

310 N. Mary Avenue • Sunnyvale, CA 94086
Tel: 408-735-5800 • Fax: 408-735-6643

Cylink Corporation (Singapore)
Tel: +65-336-6577
Fax: +65-334-1429

FEATURES

Hardware

- Coverage up to 3 miles with directional antenna
- Capable of linking networks in multiple buildings
- Data Rate: 2 Mbps
- Spread Spectrum radio technology: 902-928 MHz
- No license required for operation
- Power output 250 mw
- Uses IEEE 802.3 Ethernet protocol (IEEE 802.5 Token Ring available soon)
- Media access protocol: Ethernet CSMA/CA
- Optional DES encryption chip
- Compatible with all SOLECTEK, NCR, and DEC wireless products
- One year limited warranty (optional 2 year warranty)
- Toll-free support

AirBridge Software

- MAC layer operation
- Transparent bridge forwarding and filtering
- Compatible with all Ethernet network operating systems (NOS) including all versions of NetWare and NetWare Life, Microsoft LAN Manager, 3Com 3+, DEC Pathworks, Banyan Vines, IBM LAN, TCP/IP, and Artisoft LANtastic

SPECIFICATIONS

AIRLAN/Bridge Unit

Height:	3.4 in.
Width:	13.0 in.
Length:	15.7 in.
Weight:	14 lbs.
Power Consumption:	110-120 VAC 60 Hz 73 Watts
Certification:	FCC Class B
Temperature:	0°C to 40° C

CONFIGURATION

The minimum AIRLAN/Bridge configuration requires one bridge unit to be installed at each building location to be linked. Multiple bridge units can be installed to link more than two buildings. The YAGI antenna is mounted on the roof of the building, or in an area with an unobstructed view of the reciprocal antenna.

(Note: Solectek recommends the use of an optional VGA monitor and keyboard when installing the units and positioning the antennas.)

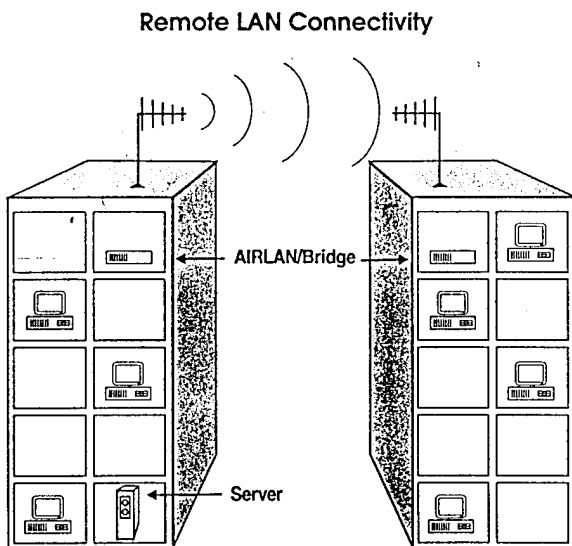

AIRLAN Pays For Itself In Less Than One Year!

	AIRLAN	T-1	DDS
Speed	2 Mbps	1.5 Mbps	54/64 Kbps
Installation*	\$ 0	\$1,300	\$1,200
Monthly Fees	\$ 0	\$ 640	\$ 400
Annual Fees	\$ 0	\$7,680	\$4,800
CSU/DSU	\$ 0	\$1,500/end	\$1,100/end
Remote Ethernet Bridge**	\$4,999/end	\$2,300/end	\$1,900/end
Total Cost Year 1	\$9,998	\$16,580	\$12,000
Total Cost Year 2	\$ 0	\$ 7,680	\$ 4,800

* Assumes a 1 mile link; Pacific Bell installation and fees.

** Long distance directional antennas extra.



Solectek Corporation
6370 Nancy Ridge Drive
San Diego, CA 92121
(800) 437-1518
(619) 450-1220 Tel
(619) 457-2681 FAX

Made in the U.S.A.

AIRLAN is a trademark of Solectek Corporation.

All other trademarks are the property of their respective companies.

Developer tested only. Novell makes no warranty with respect to this product.

708-00513

Other AIRLAN Products from Solectek

AIRLAN/PCMCIA is a credit card sized wireless Ethernet adapter designed to provide complete mobility among notebook computer users equipped with a single Type II PCMCIA slot. This self-contained unit is ideal for roaming users who require instant access to the LAN. Compatible with all SOLECTEK, NCR, and DEC wireless products.

AIRLAN/Internal are wireless network interface cards (NICs) designed to easily extend wired Ethernet networks. Available in AT and Micro Channel versions, these wireless network adapters support all major network operating systems and use spread spectrum radio signals to penetrate walls, ceilings and floors up to 800 feet from the server.

AIRLAN/Hub is a wireless access point which links an AIRLAN wireless network to a wired LAN. It can be used to easily integrate multiple topologies with AIRLAN workgroups, and eliminates wireless distance limitations by connecting to any point on the wired backbone.

AIRLAN/Parallel is a wireless parallel port LAN adapter which eliminates the need to open a PC and install an adapter card. It is ideally suited for mobile network needs, particularly among portable computers.



System

Single Hop Performance:

System Gain	118 dB nom
BER Non-faded	<10 ⁻⁹
Acquisition Time	200 msec, max
Transmission Delay	50 µsec, max (radio only) 100 µsec, max (10 mile path) 200 µsec, max (30 mile path)

Channel Plan (Std)

Pair A	2.410 GHz / 2.453 GHz
Pair B	2.430 GHz / 2.473 GHz

Transmitter

Output Power	1W max at antenna port (+28 dBm nom, +27 dBm min)
Spurious/Harmonics	-65 dBc
Frequency Range	2.4 - 2.4835 GHz
Frequency Selection	Synthesizer DIP switch
Increments	100 kHz
IF Frequency	70 MHz
Modulation	QPSK
Coding	Direct sequence
Code Length	127 bits
Spreading Rate	16 times

Antenna/Diplexer

Antenna	2, 4, 6 foot parabolic recommended
Mechanics	External antenna, Antenna Coupling Unit integral to shelf
Antenna Port	N-type female connector
Impedance	50 ohms
Return Loss	17 dB minimum
Frequency Spacing	43 MHz T-R (std)
RF Filter Type	7 cavity

Receiver

Noise Figure	6 dB max at antenna port
Receive Level	-40 dBm nominal -30 dBm maximum, no errors 0 dBm maximum, no damage -90 dBm threshold (1E-6 BER)
Image Rejection	80 dB minimum
AGC Range	60 dB
Frequency Range	2.4-2.4835 GHz
Frequency Selection	Synthesizer DIP switch
Increments	100 kHz
IF Frequency	70 MHz
Processing Gain	>10 dB

Digital Interface

Digital Capacity	1 x T1
Data Rate	1.544 MB/s
Digital Interface	DSX-1, meets CCITT G.823 AT&T Pub 62411 Bellcore TR-TSY-000499
Connector	15-pin, D-type subminiature female, DTE, or Bantam jacks (2)
Line Code	AMI or B8ZS (strap selectable)
Line Build Out	0-280 feet/280-660 feet

Indicators, Test Points, Alarms

Transmit	LED's	MOD ALM (logic level), XMTR ALM, BPV, DATA LOSS, AIS
	Test Points	VAR (synthesizer varactor voltage), +10V, +5V "B", -19V, +5V, GND
Receive	LED's	EYE (BER threshold), RF LEV, CHIP SYNC LOSS, RCVR ALM
	Test Points	EYE I, EYE Q, CLOCK, AGC I, EYE I AMP, EYE Q AMP, VAR, +10V, +10V "B", +5V, -15V, GND

Temperature and Environment

Meets all specs	0 to +50 deg C
Operational	-10 to +55 deg C
Storage	-40 to +70 deg C
Humidity	95% non-condensing
Altitude	15,000 feet

Power

Input Voltage	-21 to -56 V DC Optional AC power supply
Power Consumption	22 W @ -24V DC, 24W @ -48V DC
Fuse	2A 3AG (fast-blow)
Connectors	Barrier strip, plug-in type

Mechanics

Width	17.2"
Height	3.5"
Depth	15"
Weight	13 lbs

FCC Information

FCC Identifier	HZB-LYNX12
Rule Parts	Part 15.247
Frequency Range	2.4-2.4835 GHz
Output Power	1 Watt max.

All specifications are subject to change without notice.



310 Harbor Blvd. • Belmont, CA 94002 • (415) 592-8832
Telex (VIA RCA) 295114 WESMUX • Fax (415) 592-4249

Western Multiplex designs and manufactures
quality communications equipment:

Microwave Radio	Baseband Amplifiers	Pilot Equipment
Frequency Conversion	Baseband Filters	Video Equipment
Frequency Generation	Baseband Bridges	Test Equipment
Protection Systems	Baseband Accessories	Translation Equipment

RangeLAN2/Bridge

RangeLAN2/Bridge Specifications

Network information

Network Interfaces

Ethernet: 10BASE5 (Thick) 15 pin AUI
10BASE2 (Thin) BNC
10BASET(Twisted-Pair)

Network Support IEEE 802.3 Ethernet
RangeLAN2 Wireless

LAN card interfaces

Wireless RangeLAN2/ISA
Wired Standard Ethernet adapter

Communication Speeds

RangeLAN2/ISA: 1.6Mbps (uncompressed)
Ethernet: 10Mbps

RangeLAN2/ISA specifications

Network information

Media access protocol: RangeLAN2 CSMA/CA
(Proxim version of CSMA/CA optimized for spread spectrum
radio; includes patented contention management protocol)

Error detection/correction: Spread spectrum encoding, decoding

Addressing: IEEE compliant

Ethernet standard compliancy: IEEE 802.3 packet types

Security: Hardware scrambling
Software encryption through:
- 10 channels
- 16 domains per network
- Over 1 million encryption I.D. choices per domain

Radio

Frequency band: 2.4 - 2.483 GHz
Radio technology: Spread spectrum
Spread spectrum technique: Frequency hopping
Independent channels: 10
Output power: 100 mW
Channel structure: 10 channels, 15 subchannels per channel

Other

Warranty: 2 years
Regulatory approval: Will meet FCC Part 15 Class B licensing requirements



Proxim, Inc.
295 North Bernardo Avenue
Mountain View, CA 94043
(415) 960-1630 Fax: (415) 964-5181
BBS: (415) 960-2419 9600 N81

This device has not been approved by the Federal Communications Commission.
This device is not, and may not be offered for sale or lease, or sold or leased until
the approval of the FCC has been obtained.

INTERSECT™ REMOTE BRIDGE

INTERSECT REMOTE BRIDGE - Ethernet

Technical Specifications

Media Support:	Thick, thin, and twisted-pair media types
Range:	Up to three miles between Intersect Remote Bridges
Maximum Throughput:	100% utilization of 2.0 Mbps
Packet Format:	Any valid IEEE 802.3 or Ethernet frame from a minimum of 64 octets to a maximum of 1518 octets, including CRC

System Requirements

Intersect Remote Bridge connects a single LAN segment at a time when used in conjunction with another such licensed unit. To connect two physically separated Ethernet LANs, a minimum of two Intersect Remote Bridge units are required. Other configurations can be used; contact Persoft for details.

Product Components

- Intersect Remote Bridge
- One omnidirectional antenna with five-foot coaxial cable
- One directional antenna with 33-foot extension cable
- RangeFinder software for optimizing antenna alignment
- Intersect Remote Bridge User Manual

License

- Licensed for use in the United States, Canada, and Mexico. International customers, call Persoft for more information.

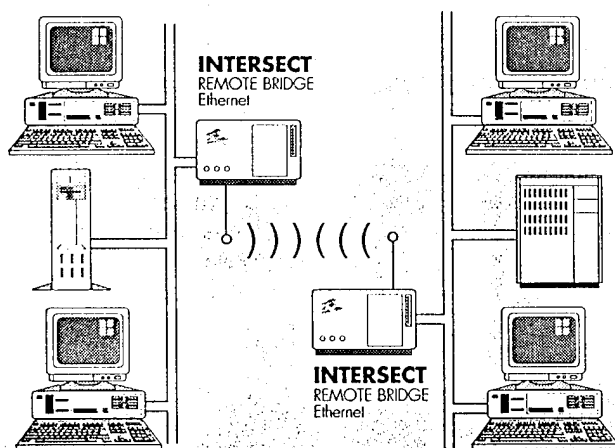

INTERSECT REMOTE BRIDGE - Token Ring

Technical Specifications

Media Support:	Type 1 shielded twisted-pair media types (any type 3 unshielded twisted pair with balun)
Range:	Up to three miles between Intersect Remote Bridges
Maximum Throughput:	100% utilization of 2.0 Mbps
Packet Format:	Any valid IEEE 802.5 source routed frame from a minimum of 18 octets to a maximum of 4504 octets

System Requirements

Intersect Remote Bridge connects a single Token Ring at a time when used in conjunction with another such licensed unit. To connect two physically separated Token Ring LANs, a minimum of two Intersect Remote Bridge units are required. Intersect Remote Bridge-Token Ring is sold in pairs only.

Product Components

- Intersect Remote Bridge
- One omnidirectional antenna with five-foot coaxial cable
- One directional antenna with 33-foot extension cable
- RangeFinder software for optimizing antenna alignment
- Intersect Remote Bridge User Manual

License

- Licensed for use in the United States, Canada, and Mexico. International customers, call Persoft for more information

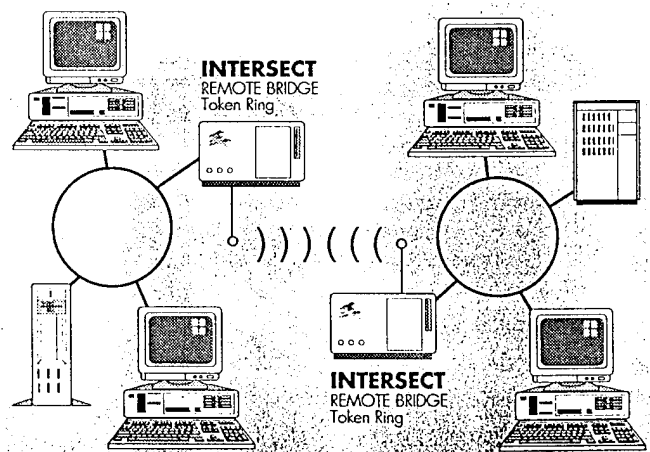

Specifications subject to change without notice.

Persoft is a registered trademark and Intersect is a trademark of Persoft, Inc. All other products and services mentioned are properties of their respective owners.

©1992, Persoft, Inc. All Rights Reserved. 9/92

persoft

CONNECTIVITY SOLUTIONS
DOS • Windows • Ethernet • Token Ring

Persoft, Inc., 465 Science Dr., P.O. Box 44953, Madison, Wisconsin 53744-4953 U.S.A., Phone (608) 273-6000, Fax (608) 273-8227
European Headquarters, World Trade Center, Beursplein 37, P.O. Box 30237, 3001 DE Rotterdam, The Netherlands



P.O. Box 84630
San Diego, CA 92138-4630
5795 Kearny Villa Rd
San Diego, CA 92123

January 25, 1994

CNC TECHNOLOGIES
500 Dover Blvd.
Lafayette, LA 70503

Attention: Mr. David Brumley

Subject: BMS Datalink Systems
Multiple Dolphin/Sea Lion

Dear David,

I have sent you an abridged copy of the technical description of the system BMS is providing to the Coastal Systems Station. This system provides only for communication and control to a single dolphin remote vehicle. However, several vehicles could be controlled by the same mother-ship station by using different frequencies for each dolphin and a frequency agile receiver at the mother ship. Control data (downlink) and sensor data (uplink) signals would be done sequentially to each dolphin. I have also supplied a budgetary hardware quote so you can evaluate the relative cost of the microwave components.

Please review this data and then we can discuss your requirements in more detail.

Very truly yours,

A handwritten signature in cursive script that reads "R.B. Anderson". The signature is written in dark ink and is positioned above the printed name and title.

R.B. Anderson
Manager Government Sales

RBA:ke



**Broadcast
Microwave
Services, Inc.**

P.O. Box 84630
San Diego, CA 92138-4630
5795 Kearny Villa Rd
San Diego, CA 92123
Phone: 619/560-8601
FAX 619/560-1637

Naval Coastal System Station
3925 Revision A
November 2, 1993
60 Days

Customer: _____
Quotation #: 120 Days ARO
Date: Net 30
San Diego, California
* Deliveries made within California
are subject to CA state sales tax.

CONTINUATION SHEET

ITEM	QUANTITY	DESCRIPTION	UNIT PRICE	TOTAL PRICE
		<u>SHIPBOARD DATA TERMINAL (SDT)</u>		
1.1	1 ea	Command Transmitter TBT-200-10ATL 1710-1850 MHz, Agile 10 Watts, L-Band	\$11,950.	\$ 11,950.00
1.2	1 ea	Transmitter Control Box TCB-100	750.	750.00
1.3	1 ea	Diplexer	3,750.	3,750.00
1.4	1 ea	Video Receiver TBR-200-AVL 1710-1850 MHz, Agile Data Subcarrier Demodulator 115 VAC	14,150.	14,150.00
1.5	2 ea	Data Receiver TBR-200-AVL 1710-1850 MHz, Agile 115 VAC	14,150.	28,300.00
1.6	2 ea	Pulse Forming Network PFN-2800	2,950.	5,900.00
1.7	1 ea	IRIG VCO Channel Bank 6 ea VCO	11,950.	11,950.00
1.8	1 ea	Steerable Antenna & Pedestal TBA-2000A, 2'x4' Antenna Feed	24,950.	24,950.00
				3

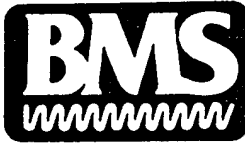

**Broadcast
Microwave
Services, Inc.**

P.O. Box 84630
San Diego, CA 92138-4630
5795 Kearny Villa Rd
San Diego, CA 92123
Phone: 619/560-8601
FAX 619/560-1637

Customer: Naval Coastal Systems
Quotation #: 3925 Revision A
Date: November 2, 1993

CONTINUATION SHEET

ITEM	QUANTITY	DESCRIPTION	UNIT PRICE	TOTAL PRICE
1.9	1 ea	Pan & Tilt Controller	16,000.	16,000.00
1.10	Set	Interconnect Cables (50 Feet)	2,350.	2,350.00
1.11	1 ea	LNA Assembly LNA-202	3,850.	3,850.00
1.12	1 ea	RF Power Splitter	2,850.	2,850.00
1.13	1 ea	Antenna Tower (25') w/Guying System	8,000.	8,000.00
1.14	1 ea	Test Cable and Attenuator	1,800.	1,800.00
			Ship Sub-Total	\$136,550.00
		<u>ROV DATA TERMINAL (RDT)</u>		
2.1	1 ea	Video Transmitter TBT-200-10AVL 1710-1850 MHz, Agile w/Data Subcarrier 28 VDC	\$12,700.	\$ 12,700.00
2.2	2 ea	Data Transmitter TBT-200-10AVL 1710-1850 MHz, Agile 28 VDC	11,950.	23,900.00
2.3	3 ea	Transmitter Control Box TCB-100	750.	2,250.00
2.4	1 ea	Diplexer and Circulator Assembly	4,450.	4,450.00
2.5	1 ea	Command Receiver TBR-50ATL w/LNA 1710-1850 MHz, Agile 28 VDC	14,800.	14,800.00
2.6	1 ea	Receiver Control Box RCB-100L (28 VDC)	750.	750.00



P.O. Box 84630
 San Diego, CA 92138-4630
 5795 Kearny Villa Rd
 San Diego, CA 92123
 Phone: 619/560-8601
 FAX 619/560-1637

Customer: Naval Coastal Systems
 Quotation #: 3925 Revision A
 Date: November 2, 1993

CONTINUATION SHEET

ITEM	QUANTITY	DESCRIPTION	UNIT PRICE	TOTAL PRICE
2.7	2 ea	Pre-Mod Transmit Filter Assembly PMF-4000	3,950.	7,900.00
2.8	1 ea	IRIG VCO Discriminator Channel Bank 6 Channels	14,950.	14,950.00
2.9	1 ea	Interconnect Cables 15 Cables	1,800.	1,800.00
ROV Sub-Total				<u>\$ 83,500.00</u>

BMT-SERIES TRANSMITTERS

BMT-15

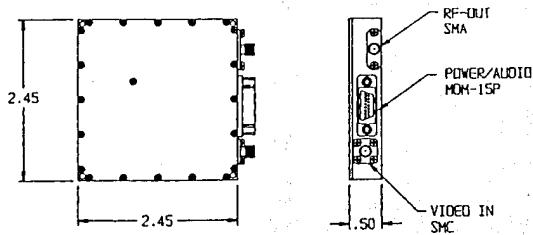

BMT-25, 35

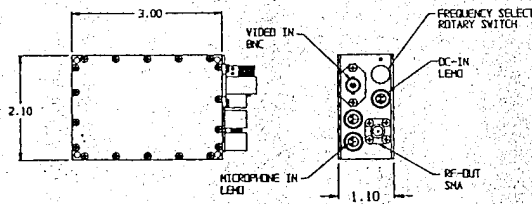

BMT-45, 55

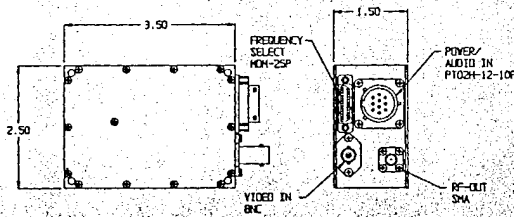

BMR-SERIES RECEIVERS

BMR-70

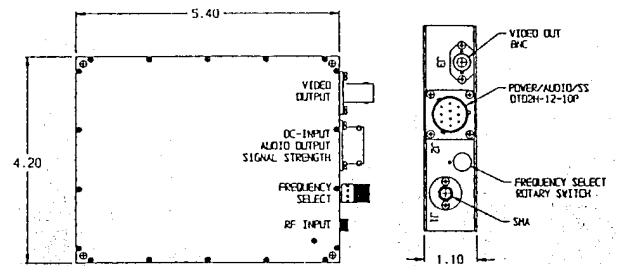

BMR-150

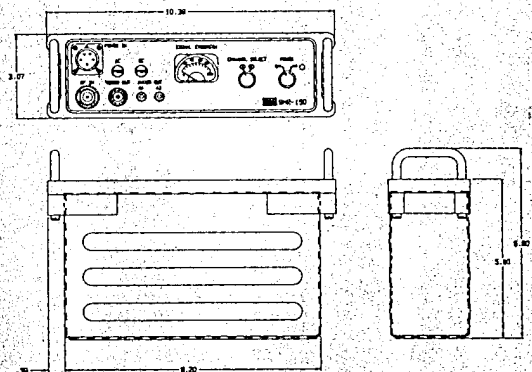

ORDERING INFORMATION

BMT-SERIES TRANSMITTERS

	<i>BMT-15</i>	<i>BMT-25, 35</i>	<i>BMT-45, 55</i>
Frequency Band	1.4 - 5.0 GHz	1.4 - 5.0 GHz	1.4 - 5.0 GHz
Maximum Power Output	.25 watt	3 watt	10 watt
Volume	3 in ³	7 in ³	13 in ³
Weight	4 oz.	8 oz.	15 oz.

BMR-SERIES RECEIVERS

	<i>BMR-70</i>	<i>BMR-150</i>
Frequency Band	1.4 - 5.0 GHz	1.4 - 5.0 GHz
Input Power	11-32 VDC	11-32 VDC; 115/230VAC
Volume	25 in ³	150 in ³
Weight	25 oz.	under 6 lbs.

Available Receiver Options: LNA, Switchable IF, Autotrack, Remote Control
 Available Signal Formats: NTSC (525 lines), PAL (625 lines)

Note: Other frequency bands and configurations available. Consult the factory for details.

SALES OFFICE

5795 Kearny Villa Road P.O. Box 84630
 San Diego, CA 92123 San Diego, CA 92138-4630
 (619) 560-8601
 FAX (619) 560-1637

BMS Broadcast
 Microwave
 Services, Inc.

Connector Pin Assignments

Input and output is through either four standard BNC connectors (standard) or a 15-pin D-type connector (optional) mounted at the computer's rear panel. Signals are available on the board at J1, a 15-pin D footprint, and jumpered to the four BNCs as shown in the figure on page 1. The user can alter this factory-set configuration by unsoldering an undesired I/O line and resoldering in the appropriate PCB J1 location.

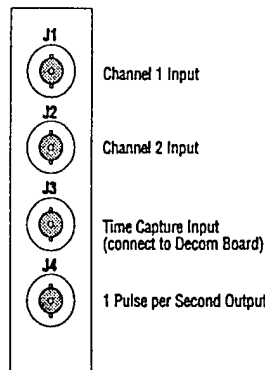

TCR741 Specifications

Inputs/Outputs

Input time codes	IRIG A, B, G, XR3, 2137, NASA 36
Carrier range	125 Hz to 800 kHz
Direction	Forward or reverse
Modulation ratio	2:1 to 6:1
Amplitude	400 mV to 10V high cycle peak-to-peak
Input impedance	600 Ω
Time capture input pulse	TTL, rising or falling edge active, 50 ns min. pulse width
Latency	300 μ sec (time from request to interrupt)
Output Pulse	1 PPS, TTL level, 75 Ω , strobe accuracy within 5 μ secs of "On Time", one carrier cycle duration

Operating Environment

Temperature	0 to 70° C
Relative humidity	10 to 80%
Altitude	1000 ft. below sea level to 10,000 ft. above sea level

Non-Operating Environment

Temperature	-50 to 125° C
Relative humidity	5 to 95%
Altitude	1000 ft. below sea level to 20,000 ft. above sea level

Physical Characteristics

Module dimensions	Full length 8-bit IBM PC AT compatible card
Slots	One 8-bit IBM PC AT slot
Power	5V @ 150 mA +12V @ 50 mA -12V @ 50 mA

Power Consumption

+5V supply	450 mA typical; 550 mA max.
+12V supply	60 mA typical; 100 mA max.
-12V supply	140 mA typical; 180 mA max.
Power dissipation	4.7 W typical (16 BTU/hr)

General Environmental

Operating temperature range	0 to 50°C
Storage temperature range	-20 to +70°C
Humidity	0 to 30% non-condensing
Weight	10 oz. (290g)
Size	Full slot

The TCR741 Module is compatible with the following Visual Instruments:

- d☆STAR (DOS) Data Acquisition Software Package
- VTS (Windows) Data Acquisition Software Package
- Telemetry SDK Software Development Kit
- Decom/Simulator Module
- Bit Synchronizer Module
- Digital-to-Analog Converter Module

LORAL
Instrumentation

15378 Avenue of Science
San Diego, CA 92128-3407
619/674-5100 Fax 619/674-5145
800/351-8483

71 Buckingham Avenue
Slough, Berkshire SL1 4PN, UK
44/753-696488
Fax 44/753-696218

Acquisition

The VTS graphical user interface offers an easy-to-learn and intuitive way of acquiring data and verifying that you have locked onto the data correctly. A fully configured system hosts several Visual Instruments modules:

Decom/Simulators, Bit Synchronizers, IRIG Time Code Readers, and Digital-to-Analog Converters for stripcharts. Command buttons, drop-down list boxes, scroll bars, and push buttons illustrate and define settings for each instrument.

Database

The VTS Decom Frame View decommutates data via an interactive graphical model of the PCM frame. By building a frame consisting of rows and columns, each cell represents a corresponding parameter. The model easily supports multi-occurrences (sub-commutation, super-commutation). Avoid any confusion over what data is actually being acquired. After acquiring and extracting data, you are ready to perform real-time activities.

Real-Time Activities

Real-time activities are broken down into three categories: display, processing, and archiving. The VTS does all three.

Displays

Animate your displays in a variety of formats, including your own! Drag-and-drop toolboxes allow you to choose from bar charts, cross plots, dials, strip charts, etc., for displaying data.

Processing

VTS converts raw values to engineering units and simultaneously performs alarm checking.

Archiving

Archive 100% of any and all data to your PC's hard disk. Later you can convert this file into an ASCII format. Increase your archiving throughput rates with faster third-party hard disks and hard disk controllers.

System Requirements

- Intel 386/486 PC (or compatible) with math coprocessor
 - DOS 5.0 or higher; Microsoft Windows 3.1 or higher
 - Windows-compatible mouse
 - 4 MB RAM minimum memory (8 MB recommended)
 - 120 MB or higher hard disk (200 MB recommended)
 - Accelerated VGA Graphics Controller recommended
 - Visual Instruments Decom/Simulator Module (DSM719)
-

VTS Data Acquisition Software is compatible with the following Visual Instruments:

- Telemetry SDK Software Development Kit
- Decom/Simulator Module
- Bit Synchronizer Module
- Time Code Reader Module

VTS Specifications

Parameter Database

Size of database	Up to 32K parameters (2 to 3K is recommended)
Portability	Import and export database in ASCII format
Data Type	Integer, unsigned, offset binary, sign magnitude, Long, and Real

Programming the Simulator

Simulate entire PCM frame	Yes
Clock	External or PC clock $\div 1$, $\div 4$, or $\div 8$
Output	NRZ-L signal with data and clock
Functions	Square wave, triangle wave, saw tooth wave, sine wave, cosine wave, random values, or constant values
Amplitudes	Programmable for each signal simulated
Offsets	Programmable for each signal simulated
Samples/Periods	Programmable for each signal simulated
Number of words	Up to 32K

Real-Time Operations

Graphic

Types of Displays	Strip charts, crossplot, bar graph, gauge, and text
Number of open windows	Determined by amount of available memory in the computer
Program display refresh rate	Yes
Graphs sizable	Yes

Processing

Polynomials or EU equations	Yes, up to 4th order polynomials: $a_0 + a_1x + a_2x^2 + a_3x^3 + a_4x^4$
Alarm monitoring	In limits, out of limits

Data Storage and Retrieval

Selectable parameters for archiving	Yes
Definition file name	Yes
Data conversion into ASCII	Yes
Throttle playback speed	Yes
Archive throughput rates	Rates of 1 to 3 Mbps depending on hard disk and controller in the computer

LORAL
Instrumentation

15378 Avenue of Science
San Diego, CA 92128-3407
619/674-5100 Fax 619/674-5145
800/351-8483

71 Buckingham Avenue
Slough, Berkshire SL1 4PN, UK
44/753-696488
Fax 44/753-696218

Connector Pin Assignments

Input or output is through a standard 37-pin D-type male connector at the computer's rear panel. For soldered connections, a standard 37-pin D-type female (ITT/Cannon DC-37S or equivalent) is the correct mating part. Insulation displacement (flat cable) connectors are available from Amp (#745242-1), 3M, Winchester, Robinson-Nugent, etc.

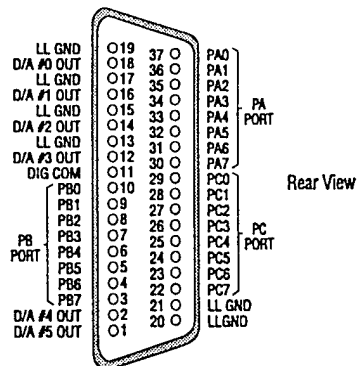

DAC770 Specifications

D/A Converters

Channels	6
Resolution	12-bits (1 part in 4095 decimal)
D/A type	DAC-80N (six used)
Latches	Double buffered with optional simultaneous update
Linearity	$\pm 1/2$ -bit
Monotonicity	$\pm 1/2$ -bit
Temperature drift of zero	1 ppm typical; 3 ppm max. (full scale)
Temperature drift of gain	15 ppm typical; 30 ppm max. (full scale)
Output ranges	0 to +5V 0 to +10V -2.5 to +2.5V -5 to +5V -10 to +10V 4 to 20 mA (current sink to ground)

Voltage Output Characteristics

Load current	± 5 mA max.
Short circuit current	40 mA max.
Output resistance	< 0.1 Ω
Settling time	4 μ s max. to 0.01% for full-scale step

Current Loop Characteristics

Type	4 to 20 mA constant current sink to ground
Output resistance	100 M Ω
Min. loop excitation voltage	+6V
Max. loop excitation voltage	+36V

Digital Inputs/Outputs

Type	8255 PPI
Number	24 lines (three 8-bit ports)
Control	Each port software programmable as input or output Supports all 8255 operating modes

TTL/DTL/CMOS compatible input characteristics:

Logic low level	-0.5V min. to +0.8V max.
Logic high level	+2.4V min. to +5.0V max.
Input current	+1 μ A (logic high or low)

TTL/DTL/CMOS compatible output characteristics:

Output low sink current	1.1 mA at $V_{ol} = 0.45V$
Output high source current	-200 μ A at $V_{oh} = 2.4V$
Darlington drive current*	-1 mA min. -4 mA max. at 1.5V

*Available on any 8 pins simultaneously from PB and PC ports

Power Consumption

+5V supply	450 mA typical; 550 mA max.
+12V supply	60 mA typical; 100 mA max.
-12V supply	140 mA typical; 180 mA max.
Power dissipation	4.7 W typical (16 BTU/hr)

General Environmental

Operating temperature range	0 to 50°C
Storage temperature range	-20 to +70°C
Humidity	0 to 30% non-condensing
Weight	10 oz. (290g)
Size	Full slot

The DAC770 Module is compatible with the following Visual Instruments:

- d☆STAR (DOS) Data Acquisition Software Package
- Telemetry SDK Software Development Kit
- Decom/Simulator Module
- Bit Sync Module
- Time Code Reader Module

LORAL

Instrumentation

15378 Avenue of Science
San Diego, CA 92128-3407
619/674-5100 Fax 619/674-5145
800/351-8483

71 Buckingham Avenue
Slough, Berkshire SL1 4PN, UK
44/753-696488
Fax 44/753-696218

Connector Pin Assignments

Input or output is through a standard 25-pin D-type female connector or two BNC connectors at the computer's rear panel.

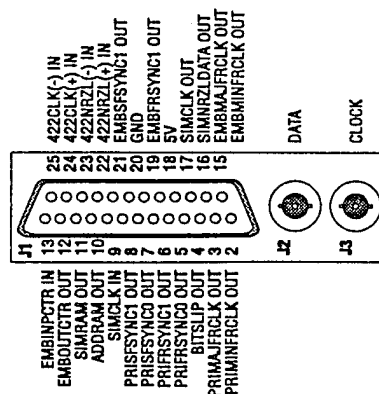

DSM719 Specifications

Decom:

Inputs

Internal	NRZ-L data and clock
External (rear panel)	2 BNC connectors (TTL levels, 75 Ω impedance or user changeable) and DB-25 (RS-422)
External clock	0° synchronous
External data	NRZ-L PCM serial
Bit rate maximum	10 Mbit/sec

Outputs

Rear Panel Connector	DB-25
Status Output	Search, verify, lock, check
Format	2 bits each for primary frame and primary subframe
Sync Pulse	Word, frame, subframe pulses
Simulator	NRZ-L data and clock

Frame Characteristics

Max bit errors in sync pattern	Programmable 0 to 64 bits
Search to lock strategy	Programmable 1 to 4 consecutive frames
Lock to search strategy	Programmable 1 to 4 consecutive frames
Data alignment	MSB or LSB
Sync polarity	Normal or alternating

Minor Frame:

Words per minor frame	1 to 32640*
Word length	8 to 16 bits variable
Sync pattern	8 to 64 bits any combination of 1,0, or X
Sync aperture	Programmable window ± 0 or ± 1 bit
Data polarity	Manual (normal/inverted) or automatic

Major Frame:

Major frame size	32,640 words*
Minor frames/major frame	1 to 8,160 maximum
Synchronization methods	Subframe ID; Sync Code; Unique Recycling Code (URC); Frame Code Complement (via URC)

Embedded Asynchronous Frame:

Embedded frame size	32,640 words maximum*
Word length	Fixed (8 to 16 bits)
Synchronization methods	Subframe ID; Sync Code; Unique Recycling Code (URC); Frame Code Complement (via URC)

* If both embedded and primary frames are being monitored simultaneously, then 16,320 words are allocated to each.

Simulator:

Functions

Capability	Exercise primary modes of operation
Simulated functions	Software-dependent
Clock	Base PC clock; PC clock $\div 4$ and 16; external clock (up to 10 MHz)
Output	NRZ-L data and clock

Power Consumption

+5V supply	1.2 Amps max.
+12V supply	60 mA typical; 100 mA max.
-12V supply	140 mA typical; 180 mA max.
Power dissipation	4.7 W typical (16 BTU/hr)

General Environmental

Operating temperature range	0 to 50°C
Storage temperature range	-20 to +70°C
Humidity	0 to 30% non-condensing
Weight	10 oz. (290g)
Size	Full slot

The DSM719 Module is compatible with the following Visual Instruments:

- d☆STAR (DOS) Data Acquisition Software Package
- VTS (Windows) Data Acquisition Software Package
- Telemetry SDK Software Development Kit
- Bit Synchronizer Module
- Time Code Reader Module
- Digital-to-Analog Converter Module

LORAL
Instrumentation

15378 Avenue of Science
San Diego, CA 92128-3407
619/674-5100 Fax 619/674-5145
800/351-8483

71 Buckingham Avenue
Slough, Berkshire SL1 4PN, UK
44/753-696488
Fax 44/753-696218

Connector Pin Assignments

Input or output is through two standard BNC connectors or one RS-422 (8-pin) connector at the computer's rear panel.

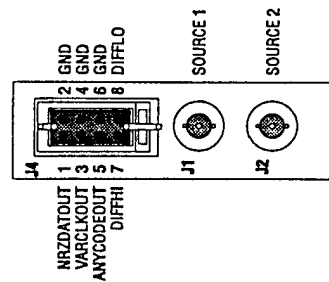

BSM730 Specifications

Inputs

IRIG code formats	NRZ-L,M,S; BiΦ-M,S; DBiΦ-M,S; DM-M,S; RZ; RNRZ-L; M2-M,S
Bit rate	NRZ codes 10 bps - 15 Mbps Other codes 10 bps - 7.5 Mbps

PCM Data:

Single-ended	Two separate BNCs
RS-422	BNC
AC offset	Up to 100% of signal amplitude at frequencies up to 0.1% of bit rate
DC offset	±20 V @ high impedance ± 8 V @ low impedance
Impedance	Single-ended; 10 KΩ, < 50 pf, nominal; or 75 Ω
Usable input range	0.25 to 20 V peak-to-peak

Outputs

BNC Connectors (TTL buffered):

NRZ-L	Data in NRZ-L form
Clock	NRZ-L data clock, 0°, 90°, 180°, or 270°
Tape	User selects analog tape output in any of the above IRIG formats

Functions

Bit decisions and synchronization	Output clock and data to PCM decommutator
IRIG code conversion	Output to analog tape or other external equipment through rear panel connector
Detector type	Integrate/Dump or Filter/Sample
Tuning resolution	0.1%
Track range	0.1 to 15.0% adjustable in 0.1% increments
Capture range	±(½ track range + ¼ loop bandwidth setting)
Loop bandwidth	Selectable 0.1, 0.3, 1, 2, 3%

Bit Error Rate:

NRZ Codes	Within 1.0 dB of theoretical up to 3.75 Mbps; within 1.5 dB up to 7.5 Mbps; within 2.0 dB up to 15 Mbps
All other codes	Within 1.0 dB of theoretical up to 1.9 Mbps; within 1.5 dB up to 3.8 Mbps; within 2.0 dB up to 7.5 Mbps
Acquisition time	Within 10 data transitions, NRZ-L, SNR ± 15 dB
Minimum transition density	3.12% with input 8 dB SNR
Sync threshold	Minimum SNR for sync acquisition is 0 dB for transition density ≥ 50%

Flywheeling with Continuous 1s or 0s

NRZ Codes	Sync is maintained through strings as long as 512 bits once every 2047 bits
Other Codes	Indefinite after sync is achieved

Conditions	SNR ≥ 12 dB; LBW = 0.1%, track range = 0.5%; No jitter, AM or baseline perturbations. The difference between the programmed bit rate and input frequency is ≤ 0.1%
------------	--------------------------------------------------------------------------------------------------------------------------------------------------------------------

Flywheeling with Data Dropouts

NRZ Codes	Sync is maintained through dropouts as long as 512 bits once every 2047 bits
Other codes	Sync is maintained through dropouts as long as 128 bits once every 2047 bits
Conditions	SNR ≥ 12 dB; LBW = 0.1%, track range = 0.5%; No jitter, AM or baseline perturbations. The difference between the programmed bit rate and input frequency is ≤ 0.1%
Soft Bit Mode	Normal or Invert

Physical Characteristics

Module dimensions	Full-length 16-bit IBM PC AT compatible card
Slots	One 16-bit IBM PC AT slot*
Power	5V @ 3.0 Amps typical

*depending on your PC, an additional slot may be required

Power Consumption

+5V supply	3 A typical ±5%
+12V supply	110 mA typical ±5%
-12V supply	175 mA typical ±5%
-5V supply	250 mA typical ±5%

The BSM730 Module is compatible with the following Visual Instruments:

- d☆STAR (DOS) Data Acquisition Software Package
- VTS (Windows) Data Acquisition Software Package
- Telemetry SDK Software Development Kit
- Decom/Simulator Module
- Time Code Reader Module
- Digital-to-Analog Converter Module

LORAL
Instrumentation

15378 Avenue of Science
San Diego, CA 92128-3407
619/674-5100 Fax 619/674-5145
800/351-8483

71 Buckingham Avenue
Slough, Berkshire SL1 4PN, UK
44/753-696488
Fax 44/753-696218

TRANSMITTERS

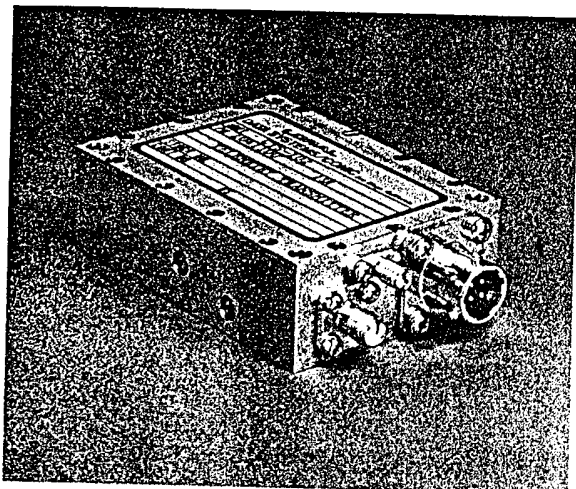

CTS-100 SERIES

Hybrid FM Telemetry Transmitters

Frequency Range:

- 2200-2300 MHz (single frequency)

Output Power:

- 2 Watts (CTS-102) • 5 Watts (CTS-105)

Input Power:

- 28, ± 4 Vdc
- CTS-102: 0.65 A max. • CTS-105: 1.5 A max.

Frequency Stability:

- $\pm 0.003\%$ of specified frequency
($\pm 0.002\%$ available)

Frequency Response:

- 10 Hz-1.0 MHz, ± 1.5 dB

Carrier Deviation:

- ± 1 MHz

Temperature Range:

- -20°C to $+70^{\circ}\text{C}$ (baseplate)

Size & Weight:

- CTS-102: 2.875" x 2.00" x 0.875"; 7 oz. max.
- CTS-105: 3.00" x 2.375" x 0.875"; 10 oz. max.

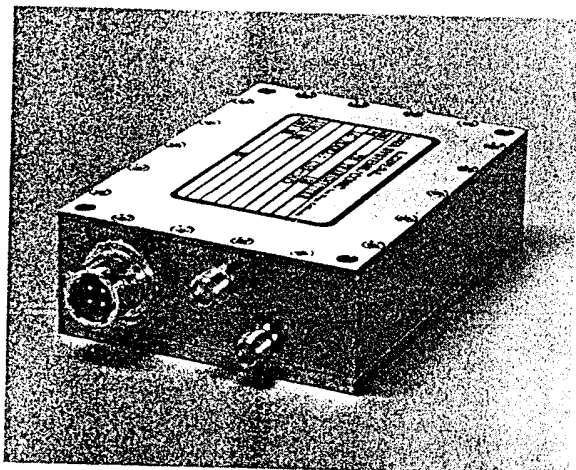

CSS-500 SERIES

Synthesized FM Transmitters

Applications: Video and Telemetry

Frequency Range:

- 1710 - 2300 MHz (2 bands); in
1.0 MHz steps over a 100 MHz BW

Output Power:

- 2 W (CSS-502) • 5 W (CSS-505)

Input Power:

- 2 W : 1A • 5 W : 1.5A • 28, ± 4 Vdc

Frequency Stability:

- $\pm 0.002\%$ per IRIG 106-86

Frequency Response:

- 10 Hz-6.0 MHz; 3 dB points

Deviation Sensitivity:

- Video: 4 MHz/Vp • TLM: 100 kHz/Vp

Temperature Range:

- -20°C to $+70^{\circ}\text{C}$ (baseplate)

Size & Weight:

- 2W/5W: 3.5" x 2.5" x 1.0"; 10 oz. maximum

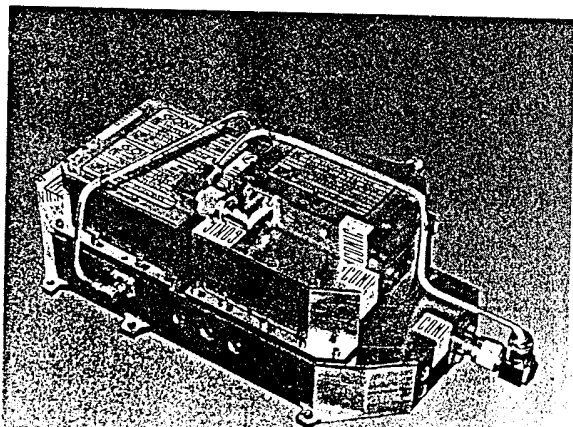

CTS-540 VI

High Power Airborne Video Transmitter

Frequency Range:

- 1710 to 1850 MHz, single frequency

Output Power:

- 40 Watts min.

Input Power:

- 28, ± 4 Vdc; 12 Amperes max.

Frequency Stability:

- $\pm 0.005\%$ of center frequency (unmodulated)

Carrier Deviation:

- ± 4 MHz (with CCIR-405 filter)

Frequency Response:

- 16 Hz to 10 MHz

Temperature Range:

- -20°C to $+70^{\circ}\text{C}$, standard; -55°C to
 $+100^{\circ}\text{C}$, optional

Options:

- Tailored frequency response
- Video compression, multi-channel

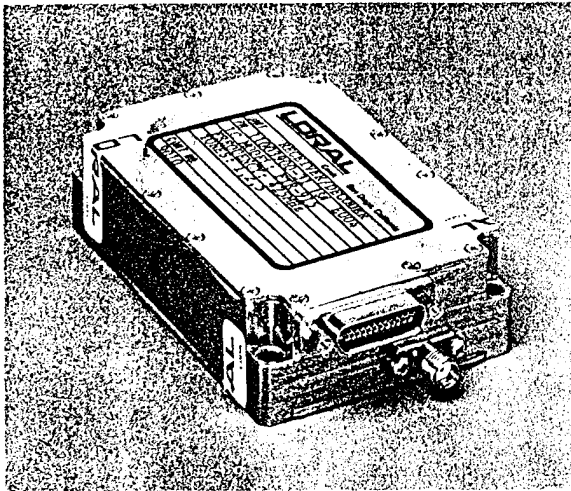

FTR-915

Miniature Flight Termination Receiver/Decoder (Fully Hybridized)

Frequency Range:

- 405–486 MHz

IF Bandwidth:

- $> \pm 90$ kHz for 3 dB response
- $< \pm 180$ kHz for 60 dB response

Threshold Sensitivity:

- $< 2 \mu\text{V}$

Command Sequence:

- Tone channel assignments can be any IRIG channel from 1 through 20

Temperature Range:

- -54°C to $+85^\circ\text{C}$

Size & Weight:

- 3.35" x 2.25" x 0.925"; 8.0 ounces max.

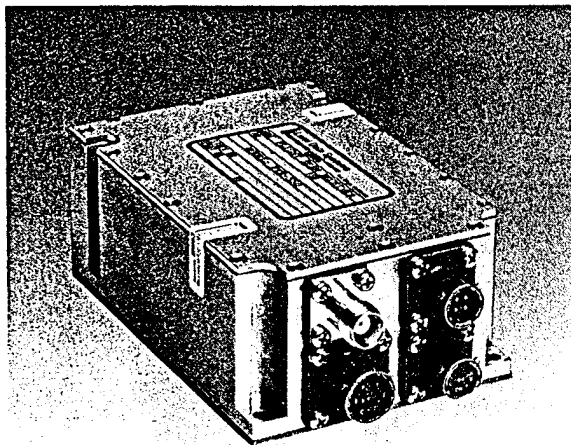

FTR-550

Flight Termination Receiver

Frequency Range:

- 405–486 MHz

Dual Conversion:

IF Bandwidth:

- $> \pm 90$ kHz for 3 dB response
- $< \pm 180$ kHz for 60 dB response

Threshold Sensitivity:

- $< 2 \mu\text{V}$

Command Sequence:

- Tone channel assignments can be any IRIG channel from 1 through 20

Temperature Range:

- -54°C to $+85^\circ\text{C}$

Size & Weight:

- 4.5" x 3.1" x 1.8"; 22 ounces max.

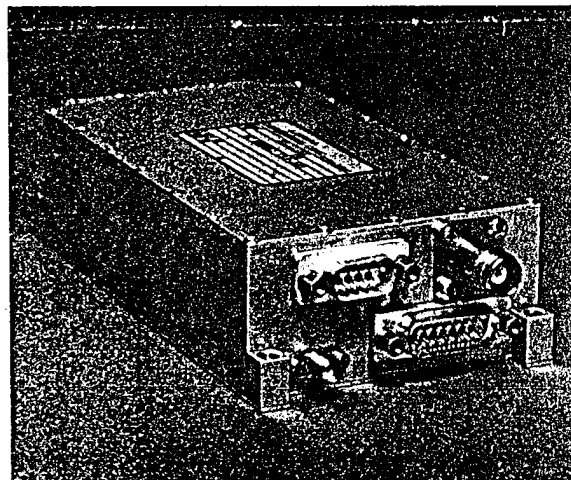

CAR-800 SERIES

FM Receivers

Features:

- Synthesized LO for remote selection of up to 200 RF carrier frequencies
- Low-noise front end for high sensitivity
- AGC provides wide dynamic range and constant group delay
- LO stability of $\pm 0.0025\%$
- Designed for medium and wide information bandwidths
- Meets missile/aircraft environments
- AM and signal strength telemetry analog

Frequency Range:

- 1.4 GHz to 2.4 GHz, standard
- 100 MHz bandwidth

IF Bandwidth:

- 200 kHz to 20 MHz, standard

Temperature Range:

- -20°C to $+70^\circ\text{C}$, standard
- -55°C to $+85^\circ\text{C}$, available

Size & Weight:

- 6.05" x 3.2" x 1.55"; 30 ounces

ENCODERS/DECODERS

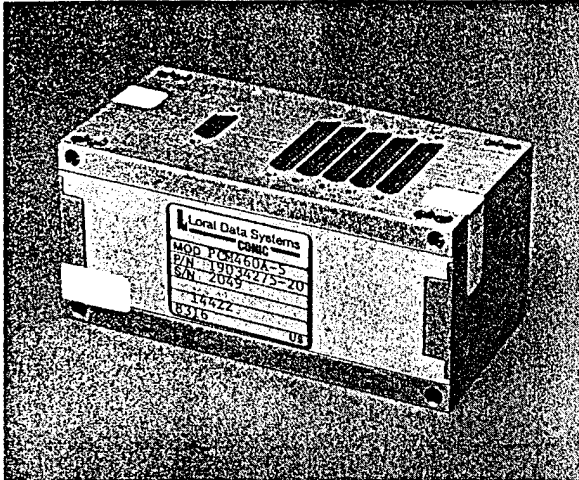

PCM-460A Miniature Encoder System

Features:

- PROM programmable
- Up to 256 data channel capacity
- Programmable gain and offset
- BIT rate up to 1 Mbps
- Modular construction for expansion

Mechanical:

Size: 1.75" x 1.80" x 4.20" max.

Environmental:

- Temperature: -40°C to +85°C
- Vibration:
 - °Sine 10g, 50 to 2000 Hz, 3 axes
 - °Random 0.2g²/Hz, 20 to 2000 Hz, 3 axes
- Shock: 275g, Half-Sine, 1 ms, 3 axes
100g, Half-Sine, 11 ms, 3 axes
- Acceleration: 110g, 3 axes
- Altitude: Unlimited

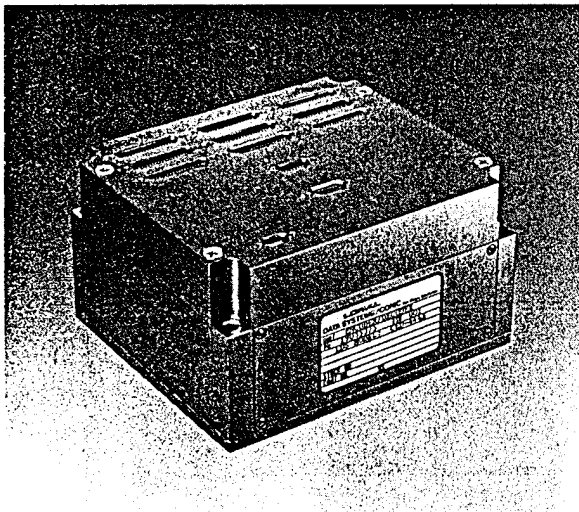

CED-444A Airborne Encoder/Decoder

Ideal for Command and Control Applications

Features:

- PROM programmable
- Analog and digital inputs
- Analog and digital output ports
- Modular construction for expansion
- Government-approved Embedded Encryption/Decryption

Mechanical:

Size: 3.0" x 5.25" x 6.30" max.

Environmental:

- Temperature: -40°C to +85°C
- Vibration: 10g rms, 3 axes
- Shock: 100g, 11 ms, 3 axes
- Acceleration: 100g, 3 axes
- Altitude: Unlimited

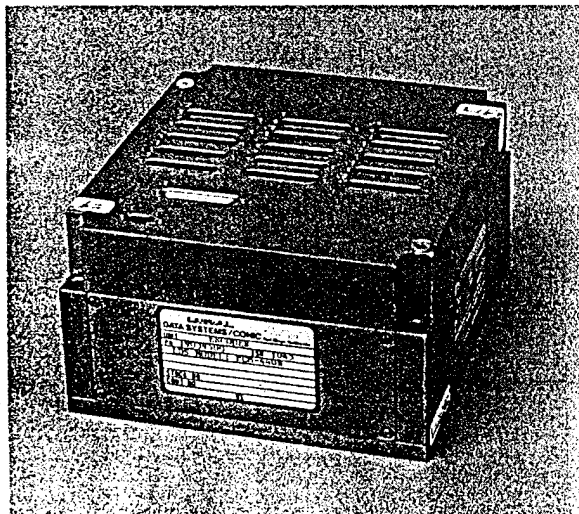

PCM-440B PCM Encoder System

Features:

- PROM programmable
- Over 1000 data channel capacity
- Government-approved Embedded Encryption/Decryption
- Operates as Master or Remote
- MIL-STD-1553 Interface Module
- BIT rate up to 3.1 Mbps
- 12-bit resolution
- Programmable gain and offset

Mechanical:

Size: 3.0" x 5.25" x 5.20" max.

Environmental:

- Temperature: -40°C to +85°C
- Vibration: 10g rms, 3 axes
- Shock: 100g, 11 ms, 3 axes
- Acceleration: 100g, 3 axes
- Altitude: Unlimited

TRANSPONDERS

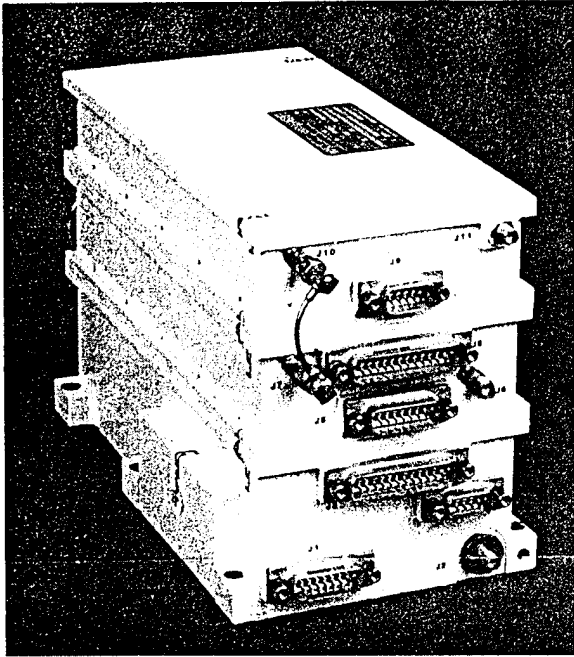

Loral Conic space-qualified subsystems and components have earned the reputation for reliability, innovation and performance over two decades; confirmed by **no space failures**. These transponders provide telemetry, tracking and command (TT&C) interfaces between their respective earth stations and spacecraft on any S-Band frequency. Both can operate in coherent and non-coherent modes. Proven packaging provides for EMI, environmental and radiation requirements consistent with long life and high reliability in space.

Features:

MODEL CXS-600

- STDN compatible
- Low input power
- Modular construction
- Swept acquisition
- Coherent; 240/221
- 2 Watts
- Ranging turnaround

MODEL CXS-800A

- SGLS compatible
- Low input power
- Modular construction
- Fast acquisition
- Coherent; 256/205
- 0.2 or 3 Watts
- Two SCO's

POWER AMPLIFIERS

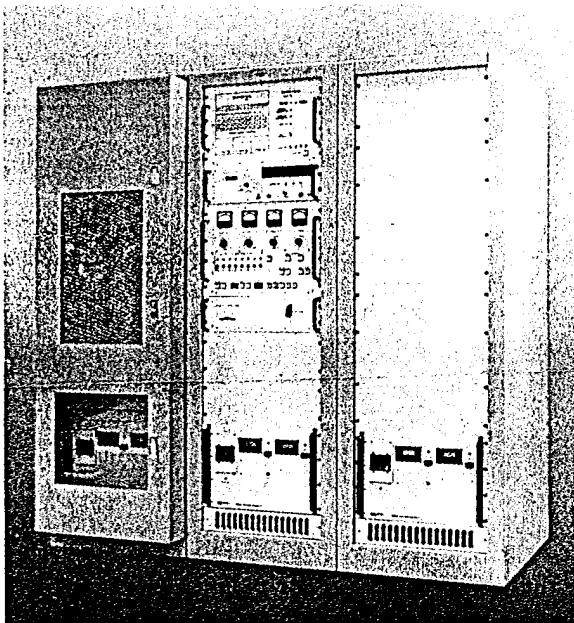

Loral Conic high-power amplifiers (HPAs) use solid-state parallel combining techniques to produce power levels at microwave frequencies formerly available only from tubes. Loral Conic builds high reliability HPAs for a variety of operating frequencies - UHF to S Band and for a wide range of applications, such as satellite ground control facilities, data links, communications, telemetry and C³ countermeasures. The unit pictured to the left is capable of producing over 2500 watts of power in the 1750 to 1850 MHz band. It was designed for use in the worldwide network of SGLS tracking stations.

Features:

- Frequency bands to 2300 MHz
- Solid-state microwave designs
- CW power levels to 10 kW
- Remote control, BITE, soft failure features
- MIL-Q-9858A quality levels
- Very high MTBF

**EMHISER RESEARCH, INC.**

2705 Old Highway 40 West
PO Box 189
Verdi, Nevada 89439-0189

TEL (702) 345-2705
FAX (702) 345-2484

Facsimile Transmittal

To:

Dave Alleman
C&C Technologies
TEL (318) 981-1442
FAX (318) 988-1016

Number of Pages to Follow: 3

From:

Emhiser Research, Inc.
Jay Lawson
TEL (702) 345-2705
FAX (702) 345-2484

Date: 28 Jan 1994

Dave,

Here is some preliminary information on our products. We are mailing a short form catalog to you that will describe our other products. The transmitter and receiver shown here are standard products, available in about 45 days ARO. The transmitter is sold for \$1,248.00 ea and the receiver for \$4,538.00. We also make digital or video transmitters and receivers.

When you decide what type of equipment will suit your needs for the Navy, we will be happy to try to provide you with the equipment to test the system. Please contact me when you have further questions

Originals Mailed
 Originals Not Mailed (unless requested)

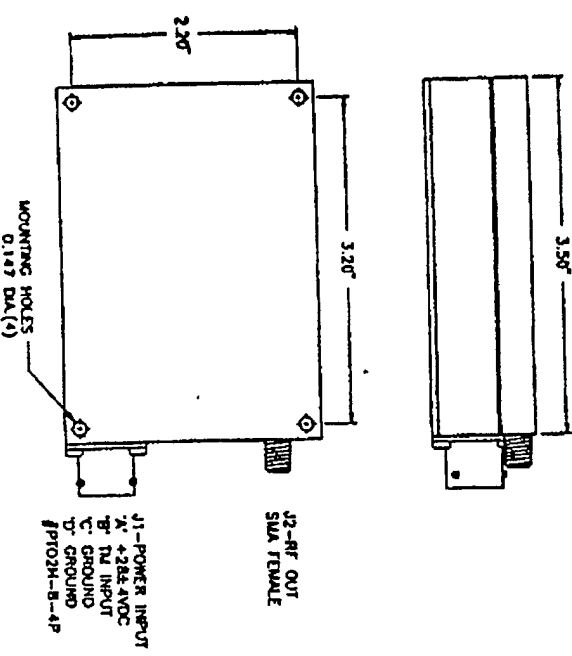
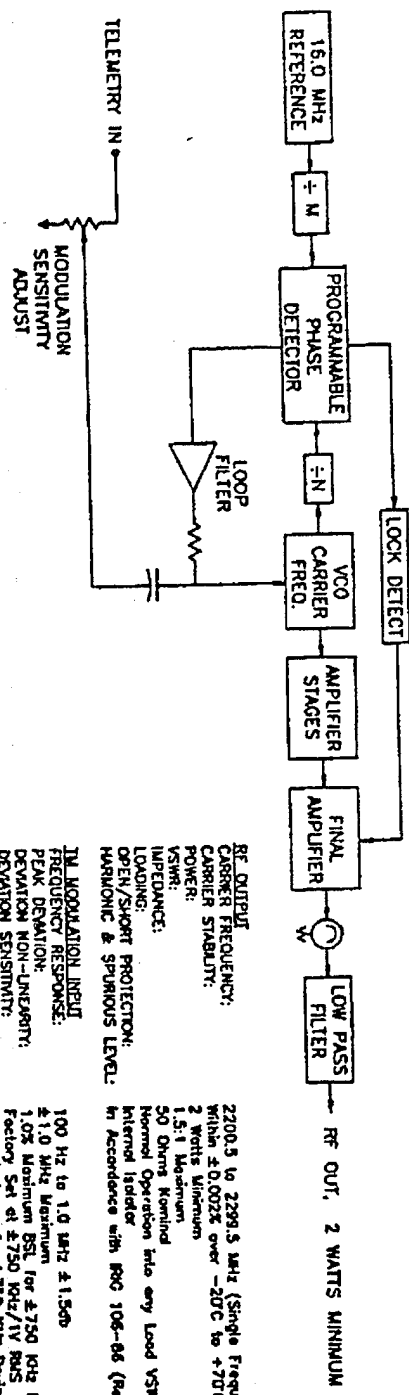

J1 - POWER INPUT
 A. +28.5VDC
 B. IN INPUT
 C. GROUND
 D. GROUND
 #PT02H-B-4P

J2 - RF OUT
 SMA FEMALE

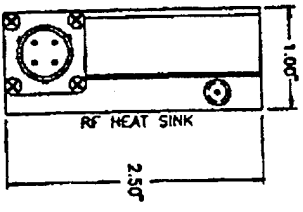

HEAT SINK

PHYSICAL CHARACTERISTICS

PER OUTLINE DRAWING
 12 oz. Maximum
 WEIGHT:

ENVIRONMENTAL SPECIFICATIONS

TEMPERATURE: Operating: -20°C to +70°C; Storage: -5°C to +125°C
 VIBRATION: 20 G's, 20 Hz to 2 KHz, 3 Axes
 SHOCK: 1/2 Sin, 100 G's Pk, 11 ms, 3 Axes
 ACCELERATION: 100 G's, 3 Axes
 ALTITUDE: Unlimited
 HUMIDITY: To 95% at any Temperature forming Frost or Condensation

POWER REQUIREMENTS

+28 ± 4 VDC: Reverse Polarity Protected
 1.0 Amp Maximum
 INPUT CURRENT:

FM MODULATION INPUT

FREQUENCY RESPONSE: 100 Hz to 1.0 MHz ± 1.5db
 PEAK DEVIATION: ± 1.0 MHz Maximum
 DEVIATION NON-LINEARITY: 1.0% Maximum BSL for ± 750 KHz Deviation
 DEVIATION SENSITIVITY: Factory Set at ± 750 KHz/1V RMS
 HARMONIC DISTORTION: 1.0% Maximum for ± 750 KHz Deviation
 5% Maximum
 10 KHz Maximum
 INCIDENTAL, PK: 100K Ohms Maximum
 INPUT IMPEDANCE: 100K Ohms Maximum

RF OUTPUT

CARRIER FREQUENCY: 2200.5 to 2299.5 MHz (Single Frequency)
 CARRIER STABILITY: Within ± 0.002% over -20°C to +70°C
 POWER: 2 Watts Minimum
 VSWR: 1.5:1 Maximum
 LOADING: 50 Ohms Nominal
 Normal Operation into any Load VSWR and Phase Angle
 Internal Indicator
 in Accordance with R90 106-86 (Revised Sep 89)

DATE	91 08 20	<p>EMHISER RESEARCH, INC. 2705 OLD HIGHWAY 40 WEST PALMBOX 189 VEGAS, NEVADA 89433-0189 U.S.A. TEL: 702-345-2705 FAX: 702-345-2484</p>
DWM	L3	
APVO		TELEMETRY TRANSMITTER 2 WATTS
DC		SINGLE FREQUENCY, AC COUPLED
CAGE CODE IDENT NO.	60666	MODEL NO. ETT-08E1A202-00

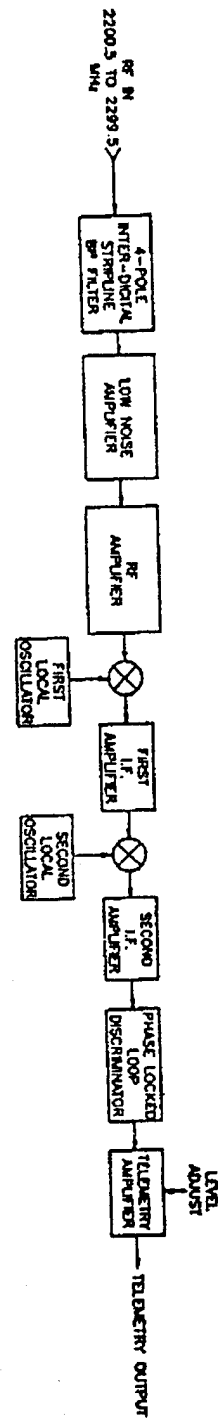

RF INPUT FREQUENCY RANGE: 2200.5 to 2299.5 MHz (Single Frequency)
APERTURE: 50 Ohms Nominal
VSWR: 1.5:1 Maximum
POWER: +10 dBm Maximum without Damage
SENSITIVITY: -90 dBm for 54%/M or 10 dB (1.0 MHz Telemetry Bandwidth)
NOISE FIGURE: 5 dB Maximum

LOSSES: Within 3.0002% over -20°C to +70°C
STABILITY: 520 MHz
1ST I.F.: 21.4 MHz
2ND I.F.: 4 MHz Nominal
RF BANDWIDTH: -60 dB Maximum

DEMODULATED TELEMETRY OUTPUT: Within 3.1dB 100 Hz - 1.0 MHz Rate to 1.5 MHz Pk-Pk Deviation
TELEMETRY RESPONSE: Factory Set to 1V Pk-Pk for 1.5 MHz Pk-Pk Deviation
OUTPUT LEVEL: 75 Ohms
IMPEDANCE:

POWER REQUIREMENTS: 28 & 4 VDC, Reverse Polarity Protected
INPUT VOLTAGE: 400 mA Maximum

ENVIRONMENTAL SPECIFICATIONS:
TEMPERATURE: Operating: -20°C to +70°C; Storage: -54°C to +125°C
VIBRATION: 20 G's, 5 Hz to 2 kHz, 3 Axes
SHOCK: 1/2 G's, 100 G's Pk, 11 ms, 3 Axes
ACCELERATION: 100 G's, 3 Axes
ALTITUDE: 100,000 Feet
HUMIDITY: to 95% of any Temperature forming Frost or Condensation

PHYSICAL CHARACTERISTICS:
DIMENSIONS: Per Outline Drawing
WEIGHT: 32 oz. Maximum

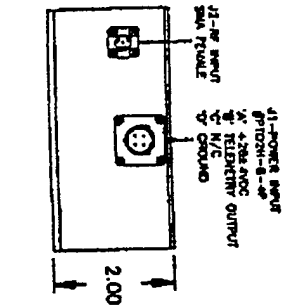
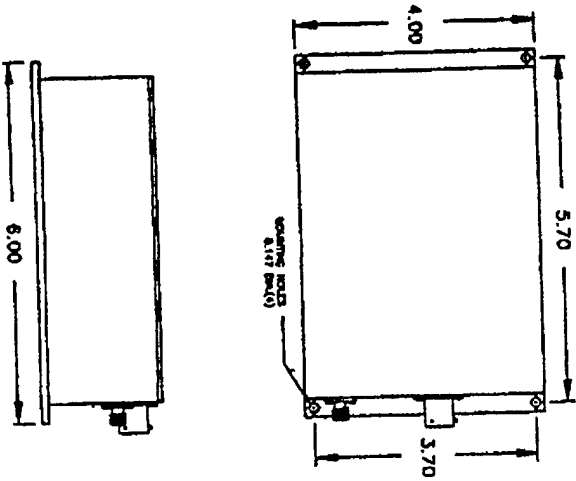

DATE	91 08 16	 EMHISER RESEARCH, INC. 2705 OLD HIGHWAY 40 WEST PALM BEACH VERDE, NEVADA 89439-0889 TEL: 702-345-2705 FAX: 702-345-2484 U.S.A.
DRAWN	LS	
APP'D		
QC		
CODE IDENT NO.	80666	MODEL NO. ETR-48E1A-00
TELEMETRY RECEIVER SINGLE FREQUENCY, AC COUPLED 2200.5 TO 2299.5 MHz		



EMHISER RESEARCH, INC. designs and manufactures a complete line of airborne and ground-based telemetry equipment.

Founded in 1978 in Ridgecrest, California by a group of telemetry engineers, the company's growth soon prompted a move to the Reno, Nevada area in 1981. Emhiser Research, Inc. now has a new research, development, and production facility in the picturesque town of Verdi (ten miles west of Reno). This facility is configured for total program management from the design and prototype stages through full production.

All Emhiser Research products are designed for harsh military environments and many have been range qualified. Numerous patents have resulted from our imaginative designs. For example, a recent phase locked loop breakthrough allows us to DC couple channelized transmitters and receivers with deviations and bandwidths ranging from narrowband through video.

Using surface mount technology and advanced RF, digital, and analog techniques, we are able to design and produce miniature, ruggedized, affordable units to your system and program needs. Our workmanship and quality system conform to the highest military standards.

Emhiser Research telemetry equipment has been supplied to all military branches on both a prime and subcontract basis. Defense companies served include: Beechcraft, Boeing, Hughes, Northrop, Rockwell, Teledyne, Texas Instruments, and many more.

Our Canadian affiliate, established in 1983, focuses on the research and development of advanced products to serve the growing international telemetry market.

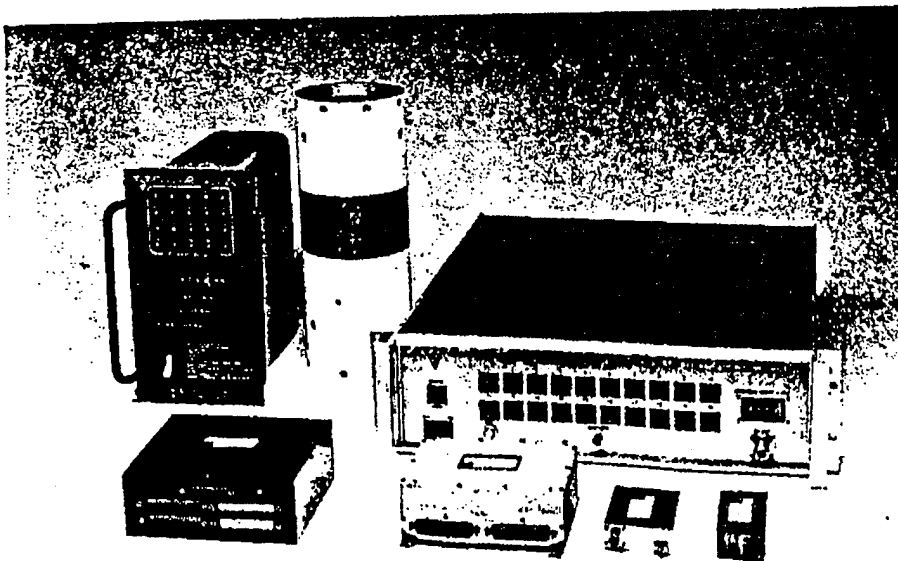

EMHISER RESEARCH, INC.
2705 Old Highway 40 West
P.O. Box 189
Verdi, Nevada USA 89439
TEL (702) 345-2705
FAX (702) 345-2484

EMHISER RESEARCH LIMITED
110 Bowes Street
Parry Sound, Ontario
Canada P2A 2L7
TEL (705) 746-4268
FAX (705) 746-4414

- Telemetry Transmitters and Receivers
- Video Transmitters and Receivers
- Command Transmitters and Receivers
- Seismic Transmitters and Receivers
- Locator Beacon Transmitters
- Satellite Transmitters
- Flight Termination Receivers
- Discriminators
- PCM Encoders and Decoders
- Voltage Controlled Crystal Oscillators

MODEL 3220-PC GENERAL DESCRIPTION

The Model 3220-PC Diversity Combiner is designed for use with either two 1400-MR or two 1200-MR Telemetry Receivers. The 3220-PC is a dual-channel optimal ratio diversity combiner capable of simultaneous pre-detection and post detection operation. It is a completely solid-state device utilizing the latest developments in logic technology, exhibiting a high degree of stability and reliability. Modular construction techniques are used throughout the unit to simplify maintenance and reduce down time.

The 3220-PC provides for wide bandwidths, improved circuitry control and fast acquisition phase lock loop. Improved control circuitry consists of the normal AGC control from the receiver and an AM weighting circuit to cover fast signal fades such as multi-path and flame attenuation. The tracking loop capture range is ± 160 KHz and the acquisition mode is fully automatic. The selected tracking loop capture range is achieved with an internal sweep circuit. Activated upon loss of lock, it drives the combiner VCO through the sweep acquisition range until lock is reacquired. The logic control function is utilized to automatically switch channel selection of the combiner when the internal phase lock loop is searching.

When operating under normal conditions, the AGC levels from the receiver are a true measure of the quality of the received data, and combiner weighting is a direct function of these levels. Certain applications (high multi-path environments, for example) may require that combiner weighting include the addition of an AM component. Normally, the AGC control adequately provides for wide dynamic ranges and slow fade rates; at high fade rates the 3220-PC utilizes a fast response internal AM detector whose output is summed with the normal AGC to provide an AM/AGC control for optimal combining under high fade rate conditions.

The combiner and associated receivers are completely independent as they do not share any closed loops. Initial setup consists of normalizing the receiver AGC slopes and zeroing out any DC offset present in the AGC voltages using only front panel controls. When operating in the local mode, the 3220-PC utilizes push button switches for selecting various modes of operation; indicators are used for monitoring signal levels and record carrier frequency. Light emitting diodes indicate the status of the logic circuitry (three for predetection, and three for the post detection circuit). Also located on the front panel are the ZERO and VIDEO LEVEL screwdriver adjustment pots which are used to adjust various levels. A phase lock open switch is used for breaking the predetection circuit phase lock loop; a push button switch is used to select local operation and an indicator lights when operating in the LOCAL mode.

Optional modules installed in the combiner allow either FM, PM, PSK or the 1458-D Multi-Mode Digital Demodulators, for real time data detection, as well as the 3295-BSF Fixed Frequency Bit Synchronizer, to be used as front panel plug-in units.

The combiner functions can be set up and controlled in a local mode utilizing the front panel controls, or remotely using either the RS-232C interface or the IEEE-488 bus. Up to ten setups comprised of Video Filter Bandwidth, Video Gain, Fine Tune and Pre-D Down Converter Frequency can be stored and recalled, locally or remotely. A front panel keyboard provides access to the microprocessor for local display and verification of selected combiner functions on easy-to-read, high visibility LED readouts.

The 3220-PC is a self-contained unit with a built-in ± 15 and ± 5 volt power supply which supplies regulated power to the modules. The unit is 19½ inches in overall depth and 7 inches in height and 19 inches wide, and is designed to be mounted in a standard 19-inch equipment rack.

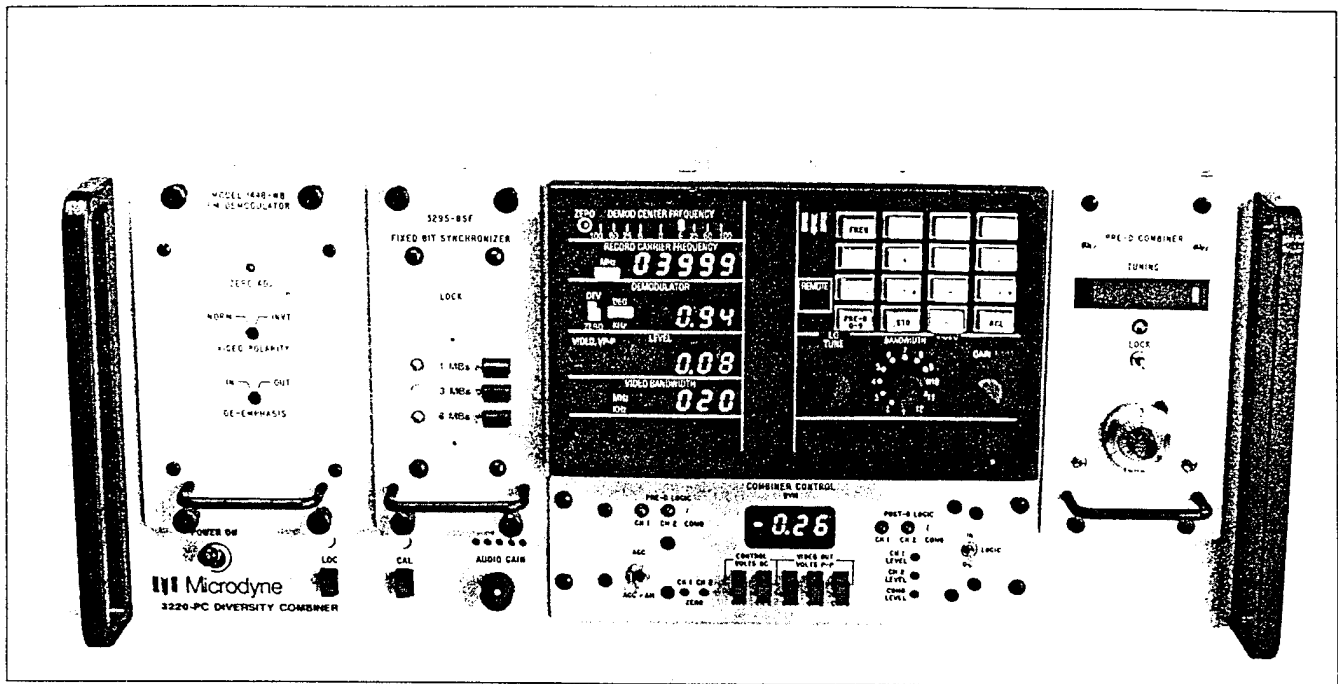

**WIDEBAND 20 MHZ PREDETECTION AND WIDEBAND POST
DETECTION COMBINING WITH OPTIONAL DEMODULATOR AND
BIT SYNCHRONIZER CAPABILITY BUILT IN**

FEATURES

- Microprocessor controlled for local or remote control using an IEEE-488 or RS-232C interface
- Optimum Ratio Diversity Combining — Over wide dynamic ranges and at extremely fast fade rates
- AM/AGC Combining — Gives optimal ratio combining when the fade rates exceed the receiver capability
- Simultaneous Predetection and Post-Detection Modes
- Logic Control of Channel Selection
- Bit-Error-Rate-Characterized — Tested in terms of BER for fading signals including pseudo-random noise fade rates
- Expanded Bandwidths — Accommodates 15 MHz Pre-D bandwidths

OPTIONS

- FM, PM & PSK Demodulators are available as plug-ins
- Programmable Pre-Detection Record Down Convertor
- Bit Synchronizer available Up to three (3) fixed bit rate units may be installed
- Front panel plug-in accessory module available for optional modules

MODEL 3220-PC SPECIFICATIONS

ELECTRICAL

Type of Combining

Simultaneous pre- and post-detection combining, dual channel, optimal ratio, AGC controlled, including an absolute value AM detector to maintain optimal ratio combining at extremely fast fade rates.

Signal-to-Noise Improvement
(equal S/N ratios)

2.5 dB

Signal-to-Noise Improvement
(unequal inputs S/N ratios)

$S/N \text{ combined} = 10 \log (Pr 1 + Pr 2) - .5 \text{ dB}$
PR 1 = C/N power ratio Channel 1
PR 2 = C/N power ratio Channel 2

PRE-DETECTION COMBINING MODE

Input/Output Frequency

20MHz

Input Level

-10 dBm \pm 15 dB

Output Level

-10 dBm

Impedance

50 Ohms

Bandwidth

15 MHz

PRE-D RECORD DOWN CONVERTER (OPTIONAL)

Input Frequency

20 MHz

Input Level

-10 dBm nominal

Impedance

50 Ohms

Output Center Frequency

Any frequency between 25 KHz to 5 MHz in 25 KHz steps

Data Bandwidth

5 MHz maximum

Output Level

0V to 2V p-p, adjustable

Output Impedance

75 Ohms

POST-D COMBINING MODE

Post-D Inputs

Frequency

10 Hz to 5 MHz

Level

1 to 8V p-p; 2V p-p nominal

Impedance

75 Ohms

Post-D Combined Outputs

Frequency

10 Hz to 5 MHz, +1 dB, -3 dB

Level

2V p-p nominal, adjustable

Impedance

75 Ohms

REMOTE STATUS

Pre-Detection Combiner

Lock/Unlock

PM/PSK Demod

Lock/Unlock

Fine Tune

\pm 250 KHz

Pre-D Record Frequency

4 digits

Video Gain

00-63

Video Bandwidth

1-6

20 MHz VCO Fine Tune

\pm 250 KHz

SPECIFICATIONS

AGC INPUTS

Slope	Approximately logarithmic
Impedance	10K Ω
Voltage Range	0 to -10V
Common Mode Rejection	Less than 0.5 dB variation in combined output with simultaneous variations of both AGC inputs over their full range.
Control Signal Rejection	Less than 0.5 dB variation in combined output over full AGC dynamic range

LOGIC INPUTS

Level	TTL compatible
Function	Selects the better channel at the combined outputs when a receiver channel fails to meet criteria for optimal ratio combining.

CONTROL FUNCTION

20 MHz VCO Fine Tune for PM Demod	Either local front panel control or remote control, utilizing the RS-232C and/or IEEE-488 interface buses; may be obtained for the following combiner functions: ± 250 KHz
Video Filters	Select 1 of 5 (or bypass)
Video Gain	Gain control setting 00-63 dB
Mode Selection	Calibrate, Local, Remote
Pre-D Record (optional)	Frequency (4 digits, 25 KHz to 5 MHz in 25 KHz steps)
Bit Synchronizer (optional)	Bit Rate: Fixed (customer specified) (optional) up to three units may be installed in the front panel slot NRZ 100 BPS to 10 MBPS BI- ϕ 50 BPS to 5 MBPS

MECHANICAL

Weight	Approximately 60 pounds
Size	7" H x 19" W x 19.5" D

POWER REQUIREMENT

120/240V AC, 50-400 Hz
Less than 80 Watts

ENVIRONMENTAL

Temperature Range	
Operating	0 to 50°C
Storage	-62° to +70°C
Altitude	
Operating	to 15,000 feet
Storage	to 50,000 feet
Relative Humidity	to 95%



Microdyne

Excellence In Communications Technology

P.O. Box 7213 • 491 Oak Road • Ocala, Florida 32672-0213
(904) 687-4633 • Fax (904) 687-3392

REPORT DOCUMENTATION PAGE

Form Approved
OBM No. 0704-0188

Public reporting burden for this collection of information is estimated to average 1 hour per response, including the time for reviewing instructions, searching existing data sources, gathering and maintaining the data needed, and completing and reviewing the collection of information. Send comments regarding this burden or any other aspect of this collection of information, including suggestions for reducing this burden, to Washington Headquarters Services, Directorate for Information Operations and Reports, 1215 Jefferson Davis Highway, Suite 1204, Arlington, VA 22202-4302, and to the Office of Management and Budget, Paperwork Reduction Project (0704-0188), Washington, DC 20503.

1. Agency Use Only (<i>Leave blank</i>).	2. Report Date. March 1994	3. Report Type and Dates Covered. Contract Report	
4. Title and Subtitle. A Technical Report on Sea Lion Telemetry Systems Analysis on NRL Contract N00014-94-P-6601		5. Funding Numbers. <i>Program Element No.</i> 0603785N <i>Project No.</i> R1987 <i>Contract No.</i> N00014-94-P-6601 <i>Accession No.</i> DN252113 <i>Work Unit No.</i> 74-5137-A5	
6. Author(s).		8. Performing Organization Report Number.	
7. Performing Organization Name(s) and Address(es). C & C Technologies 500 Dover Blvd. Lafayette, LA 70503		10. Sponsoring/Monitoring Agency Report Number. NRL/CR/7440--95-0024	
9. Sponsoring/Monitoring Agency Name(s) and Address(es). Naval Research Laboratory Marine Geosciences Division Stennis Space Center, MS 39529-5004		11. Supplementary Notes.	
12a. Distribution/Availability Statement. Approved for Public Release; Distribution is Unlimited.		12b. Distribution Code.	
13. Abstract (<i>Maximum 200 words</i>). In support of the Naval Research Laboratory's Sea Lion Program to instrument the remotely operated vehicles with multibeam bathymetry and imagery systems, it is necessary to demonstrate a telemetry system capable of handling the high data rates characteristic of this sensor suite at ranges of several miles on moving platforms. The telemetry system will have the capacity to deliver data at very high rates (possibly up to 8 megabits per second). Such a system will facilitate the relay of bathymetric data from the Sea Lions to a mother ship. SPECIFIC			
14. Subject Terms. Autonomous; Vehicles; Sensors; Dolphin/EM100; Sea Lion; Multibeam Acoustic Sounding; Hydrographic Survey Sensor.		15. Number of Pages. 34	
		16. Price Code.	
17. Security Classification of Report. Unclassified	18. Security Classification of This Page. Unclassified	19. Security Classification of Abstract. Unclassified	20. Limitation of Abstract. SAR