

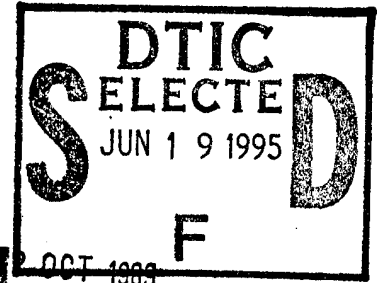

DEPARTMENT OF THE ARMY  
ARMY DEVELOPMENT AND EMPLOYMENT AGENCY  
FORT LEWIS, WASHINGTON 98433-5000



REPLY TO  
ATTENTION OF:

MODE-EXD

MEMORANDUM FOR

Commander, CACDA, ATTN: ATZL-TSM-MC (COL Duckworth), Fort Leavenworth, KS  
66027-5300

PM OPTADS, ATTN: SPIS-CC-OTDS-PM (COL Doyle), Fort Monmouth, NJ 07703

SUBJECT: Results of Experimentation with MCS Segment 10.02.1 Software

1. **PURPOSE.** The purpose of this memorandum is to present the results of experimentation with MCS 10.02.1 software to include testing methodology used by AES. Since no formal issues for experimentation were provided AES (other than to determine whether fixes/enhancements to MCS segment 10.02.1 worked) this report will provide a chronology of AES experimentation and the findings, conclusions and recommendations concerning the software. More detailed procedures/findings are documented in the enclosed OMNIBUS Contractor's reports. Since AES does not have access to the MCS 10.02.1 source code, it can only define test conditions and results.

2. **BACKGROUND.**

a. On 5 September 1989, AES received nine copies of MCS Segment 10.02.1 software from Ford Aerospace, Leavenworth, Kansas. A Ford Aerospace tester accompanied the software and briefed AES personnel on the changes made to MCS Version 10.02 software.

b. ADEA initially conducted two days of laboratory evaluation (6-7 Sep 89) on the software concentrating primarily on those fixes/enhancements that had been made in the following areas: File Transfer, SUMREP, Free Text Message, and Tape Copy. Commercial autodial capability was not examined. In addition, AES evaluated the training implications of the fixes/enhancements. Results of the initial experimentation were documented and forwarded to TSM MCS and PM OPTADS on 12 September (Enclosure 1).

c. On 7 September, the results of the laboratory experimentation were reviewed with the 9ID(MTZ) G3/MCS office and a decision made to issue the 10.02.1 software to the 9ID(MTZ) for use on CPX CABER CALM. The decision to accept the software was based on the fact that the fixes made to MCS 10.02.1 were sufficient improvement to warrant issue a week prior to a division CPX. The 9ID(MTZ) used MCS 10.02.1 on CPX CABER CALM during the period 11-15 September. During the CPX, AES and Ford Aerospace personnel evaluated the software as it was being used.

This document has been approved  
for public release and sale; its  
distribution is unlimited.

19950508 059

2 OCT 1989

MODE-EXD

SUBJECT: Results of Experimentation with MCS Segment 10.02.1 Software

d. On 14 September after reviewing software usage during the CPX, it was decided that additional laboratory evaluation was required to examine SITDEF parameters, relay problems with the file transfer utility and the use of multiple address lists. Representatives from AES, 9ID(MTZ), Ford Aerospace and PM OPTADS participated in that review process. A methodology was developed for an additional week of laboratory experimentation and scheduled for 19-22 September. The OMNIBUS contractor provided AES an evaluation of the CPX CABER CALM observations on 19 September (Enclosure 2).

e. The OMNIBUS Contractor completed the laboratory evaluation on 25 September and provided AES a final report on 26 September (Enclosure 3).

f. AES experimentation included using the software in both a pure MCS environment and in the 9ID(MTZ) environment using packet-switching.

### 3. FINDINGS.

#### a. File Transfer Relay.

(1) Using MCS 10.02, file transfer problems (relay through a TCP) were experienced approximately 95% of the time resulting in a crash of the relaying TCP. Similar relay problems did not occur with 10.02.1. File transfer problems occurred less than 5% of the time with less catastrophic results.

(2) File transfer operations performed well with one, five and ten page text files created in the Integrated Business Package word processor.

(3) The file transfer utility continued to work well until eight aborted file transfer messages were accrued during a given working session in MCS. After eight file transfer messages had aborted, for any reason, continued file transfer operations were not feasible until the user restarted MCS. File transfer on the LAN was not affected by this condition.

(4) Use of multiple address lists was not a factor in any problems encountered with file transfers.

#### b. Free Text Message.

(1) Transmission of Free Text messages of page lengths of one, five and ten pages were created and transmitted successfully.

(2) Use of the Word Processing Variable Function Key (VFK) caused MCS to fail.

#### c. SUMREP.

(1) The SUMREP allows the commander the ability to look one level down using the data resident in his friendly forces data base.

2 OCT 1989

MODE-EXD

SUBJECT: Results of Experimentation with MCS Segment 10.02.1 Software

(2) The SITDEF parameters are deleted when receiving either a database replication or restoration. This occurred even with the Ford Aerospace "patch," which was not applied to 9ID(MTZ) tapes.

d. Tape Copy. The tape copy utility was successfully performed 24 times.

e. Training Considerations. Changes to the Technical Manual and a brief information paper (prepared by OMNIBUS) appeared to provide 9ID(MTZ) adequate information on the changes to MCS 10.02.

f. MCS 10.02.1 was not compatible with backup MCS 10.02 operational files or MCS 10.02 databases created prior to the CPX. These files caused the host system to crash.

4. CONCLUSIONS.

a. File Transfer Relay. Fixes made to this utility have improved its performance significantly. Very few problems were experienced during experimentation.

b. Free Text Message. Software fixes have successfully expanded message length to ten pages. The Word Process VFK must be corrected if this utility is to be used fully.

c. SUMREP. Deletion of SITDEF parameters during database replication or restoration is a serious problem that degrades the operational effectiveness of MCS 10.02.1.

d. Tape Copy. The tape copy utility functions works well and no additional efforts are required.

e. The training impact of 10.02.1 is minimal, and no special training is required.

f. MCS 10.02.1 is not compatible with 10.02.

5. RECOMMENDATIONS.

a. That Ford Aerospace perform the software engineering necessary to provide fixes for the problems noted above.

Accession For	
NTIS CRA&I	<input checked="" type="checkbox"/>
DTIC TAB	<input type="checkbox"/>
Unannounced	<input type="checkbox"/>
Justification	
By	
Distribution /	
Availability Codes	
Dist	Avail and/or Special
A-1	

2 OCT 1989

MODE-EXD

SUBJECT: Results of Experimentation with MCS Segment 10.02.1 Software

b. That a final build to 10.02.1 be completed prior to 18 October 1989 in order to provide a complete division software set to the 9ID(MTZ) before it undergoes its next CPX (6-10 Nov 89).

3 Encls

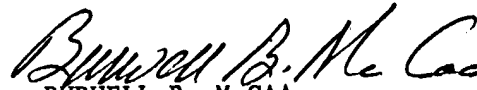

BURWELL B. McCAA  
COL, IN  
Deputy Commander

CF:

Commander, CACDA, ATTN: ATZL-CAE/ATZL-CAC, Fort Leavenworth, KS 66027

Deputy PEO, Command and Control Systems, ATTN: SPIS-CC, Fort Monmouth, NJ  
07703

Deputy PEO, Communications Systems, ATTN: SPIS-CM, Fort Monmouth, NJ 07703

Commander, Signal Center, ATTN: ATZH-CD, Fort Gordon, GA 30905

**ENCLOSURE 1**

**INITIAL RESULTS OF EXPERIMENTATION WITH MCS VERSION 10.02.1**

**(dated 12 September 1989)**



DEPARTMENT OF THE ARMY  
ARMY DEVELOPMENT AND EMPLOYMENT AGENCY  
FORT LEWIS, WASHINGTON 98433-5000

REPLY TO  
ATTENTION OF:

MODE-EXD

12 September 1989

MEMORANDUM FOR

Commander, CACDA, ATTN: ATZL-TSM-MC (COL Duckworth), Fort Leavenworth, KS  
66027-5300

PM OPTADS, ATTN: SPIS-CC-OTDS-PM (COL Doyle), Fort Monmouth, NJ 07703

SUBJECT: Initial Results of Experimentation with MCS Version 10.02.1

1. On Tuesday evening, 5 September 1989, AES received 9 copies of MCS Version 10.02.1 software from Ford Aerospace, Leavenworth, Kansas. Included with the software was a copy of the Ford Aerospace Test Report (dated 1 Sep 89). A Ford Aerospace tester, Ms Bardot, accompanied the software and briefed AES personnel on testing completed by Ford Aerospace and the status of the software.
2. ADEA conducted two days of evaluation on the software concentrating primarily on those fixes/enhancements that had been made in the following areas: File Transfer Relay, SUMREP, Free Text Message, and Tape Copy. Commercial autodial capability was not looked at. In addition, AES evaluated the training implications of the fixes/enhancements.
3. The results of the two days of evaluation are explained in the attached OMNIBUS Outline Test Report (enclosure 1) along with the methodology used in these short experiments. In summary, the following items were noted:
  - a. File Transfer Relay. This area was a significant concern to AES and the 9ID because of the catastrophic failures experienced during the 9ID July CPX. While not all file transfers were successful, the rate of success was a dramatic improvement over previous experiences.
  - b. Free Text Message. Transmission of Free Text messages of page lengths of 1, 5, and 10 pages were created and transmitted successfully. However, use of the Word Processing VFK caused MCS to fail.
  - c. SUMREP. The SUMREP utilities required installation of a patch that was not included in the file system delivered in the tapes from Ford Aerospace. The capability of the SUMREP to provide the user the ability to look one level down was evaluated and performed as required.
  - d. Tape Copy. The tape copy utility was performed 24 times and was successful in each case.
  - e. User Training Considerations. The requirements for user training with 10.02.1 were evaluated concurrently with each part of the experiment. The training implications were considered minimal and a brief information paper was prepared to assist the user. The draft changes to the software manual were provided to the user.

MODE-EXD

SUBJECT: Initial Results of Experimentation with MCS Version 10.02.1

4. Based on the results of the limited experimentation conducted by AES with MCS 10.02.1, the 9ID G3/MCS Office decided to furnish the division the software revision prior to 9ID CPX CABER CALM. On Friday morning, 8 September, 21 copies of the software were issued to the 9ID. The 9ID felt that the fixes and enhancements made to MCS 10.02.1 were significant enough to warrant issue to the division for use during their CPX. The 9ID made that decision knowing full well the implications of issuing software with additional operating instructions just prior to the CPX.

5. ADEA will further evaluate the MCS 10.02.1 software during the 9ID CPX (12-15 Sep 89). Additional laboratory examinations of the software will commence immediately after the CPX and final comments/recommendations will be provided to you on 26 September 1989.

Encl

  
BURWELL B. McCAA  
COL, IN  
Deputy Commander

**OMNIBUS  
OUTLINE TEST REPORT  
MANEUVER CONTROL SYSTEM 10.02.1**

This test did not attempt to provide for a complete validation of MCS 10.02.1. Instead, it made an operational-level evaluation of the system to determine if the 9ID (MTZ) should implement the system in CPX CABER CALM to be conducted 10 - 15 SEP 89. The objectives were derived from the specific features of the system that were known to have been changed and the requirements for user training:

- (1) File Transfer
- (2) Free Text Message Editor - Up to 10 pages
- (3) SUMREP
- (4) Tape Copy

The test was organized into four parts; one for each of the objectives identified for testing. Commercial Autodial was not included in the test at this time. Test networks were established in Bldg 8B21 for Part 1 and Bldg 8B2 for Parts 2 - 4 of the experiment (see test network diagrams).

**PART 1: FILE TRANSFER**

a. File Transfer on 4 Wire.

(1) One-Direction File Transfer with Relay. This test was performed in the network configuration displayed next. The standard 4W CDP 16000 -6DB was used. Wire was used to directly connect the PCIUs. A 40 Kbyte file was sent from the AC to the remote TCP in order to cause the local TCP to relay the message. All message transmissions were successful. The file at the receiving system was compared using UNIX utilities with the source file at the sending system and was found to be identical.

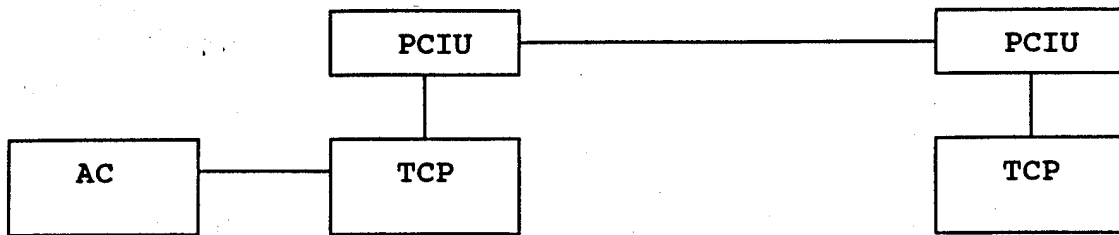

Test Network Diagram Bldg 8B21 Part 1a(1)

(2) Bi-Directional File Transfer. This test was performed in the network configuration displayed next. The standard 4W CDP 16000 -6DB was used. Wire was used to directly connect the PCIUs. A 40 Kbyte file was sent at nearly the same time from each TCP to the other TCP. Five iterations of the test produced the following results:

- 3 - Both messages acknowledged
- 1 - One of the 2 messages aborted
- 1 - 1 TCP experienced deconfiguration of Channel

The files that were transmitted and acknowledged were compared, using UNIX utilities, with the source file at the sending system, In one instance they were found to differ.

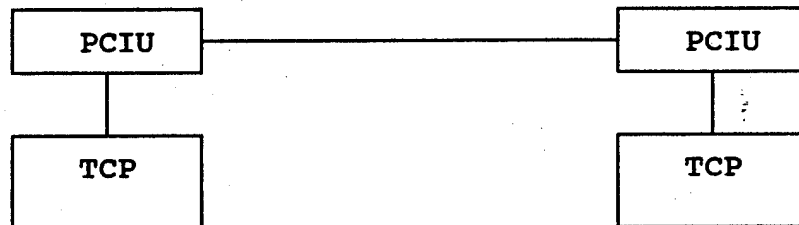

Test Network Diagram Bldg 8B21 Part 1a(2)

b. File Transfer with IPSE.

(1) One-Direction File Transfer with Relay. This test was performed in the network configuration displayed next. The standard 4W CDP 16000 -6DB was used. An IPSE was used to network the 2 systems. A 40 Kbyte file was sent from the AC to the remote TCP in order to cause the local TCP to relay the message. All message transmissions were successful. The file at the receiving system was compared using UNIX utilities with the source file at the sending system and was found to be identical.

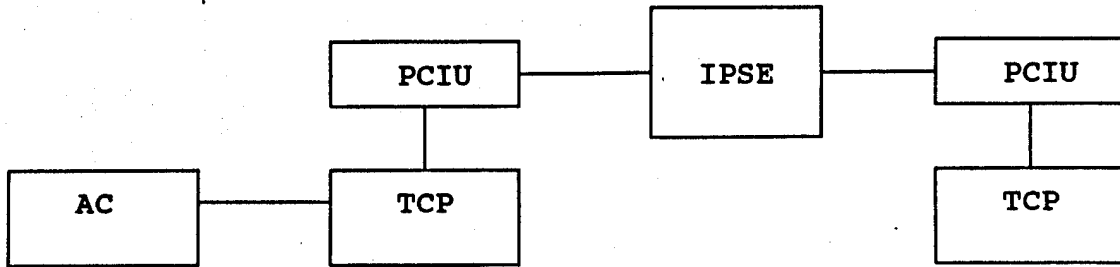

Test Network Diagram Bldg 8B21 Part 1b(1)

(2) Bi-Directional File Transfer. This test was performed in the network configuration displayed next. The standard 4W CDP 16000 -6DB was used. An IPSE was used to network the 2 systems. A 40 Kbyte file was sent at nearly the same time from each TCP to the other TCP. Five iterations of the test produced the following results:

- 4 - Both messages acknowledged
- 1 - One of the 2 messages aborted

The files that were transmitted and acknowledged were compared, using UNIX utilities, with the source file at the sending system and were found to differ in several instances.

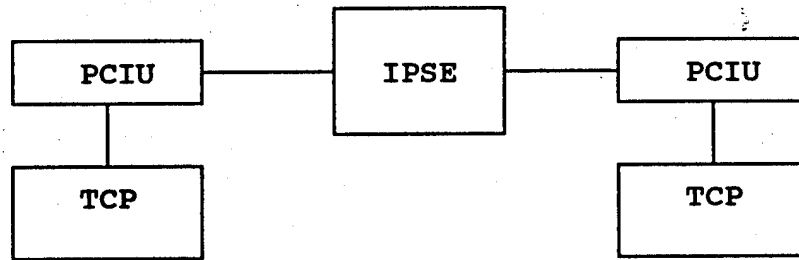

Test Network Diagram Bldg 8B21 Part 1b(2)

c. File Transfer with DCIU Surrogate. The tests outlined above were repeated with DCIU II Rev H2 (PCIU Surrogate). The results were approximately the same.

**PART 2 FREE TEXT MESSAGE EDITOR - UP TO 10 PAGES**

a. The free text message with the page count enlarged to 10 pages was evaluated for its functionality and for the effect that use of the larger message would have when transmitted to the TMC (GRiD Compass) running TMC10.02.02. Communications was performed in a network with 2 TCPs connected on a 4-wire circuit using the standard 4W CDP 16000 -6DB. Each TCP was networked to a TMC. One by a 2-wire circuit:

**CHANNEL CONFIGURATION**

```
DEVICE ..... 2-WIRE
  MODULATION ..... FSK-188C
  DATA RATE ..... 1200 BPS
  OUTPUT LEVEL ..... 0DB
  KEY LENGTH ..... 1.5 SECONDS
  STOP BITS .....
  PARITY .....
  LINE TYPE .....
COMM MODE SELECTOR CONTROL .....
WAIT CLEAR CHANNEL ..... YES
DELAY AFTER CLEAR ..... 1.0 SECONDS
PROTOCOL ..... MCS
  CIPHER MODE .....
  ERROR CONTROL ..... EDC AND TDC
  NUMBER OF RETRIES ..... 3
  RETRY INTERVAL ..... 30 SECONDS
  TRANSMISSION FORM ..... ABRIDGED
```

The other TCP was networked by secure single channel radio with a TMC system.

**CHANNEL CONFIGURATION**

```
DEVICE ..... KY-57 (VRC-12)
  MODULATION ..... NRZ
  DATA RATE ..... 16000 BPS
  OUTPUT LEVEL ..... 0DB
  KEY LENGTH ..... 1.5 SECONDS
  STOP BITS .....
  PARITY .....
  LINE TYPE .....
COMM MODE SELECTOR CONTROL ..... CMSC EMULATED
WAIT CLEAR CHANNEL ..... YES
DELAY AFTER CLEAR ..... 1.0 SECONDS
PROTOCOL ..... MCS
  CIPHER MODE .....
  ERROR CONTROL ..... EDC AND TDC
  NUMBER OF RETRIES ..... 3
  RETRY INTERVAL ..... 22 SECONDS
  TRANSMISSION FORM ..... ABRIDGED
```

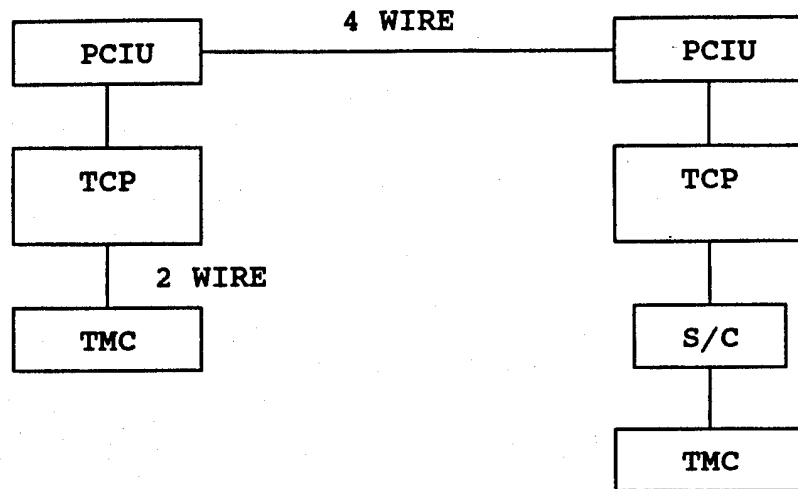

Test Network Diagram Bldg 8B2 Part 2

b. Create Free-Text Messages of page lengths of 1, 5 and 10 pages were created and transmitted from each of the TCPs to the other TCP. All transmissions were successful.

c. Messages were also sent from the TCPs to the TMC Grid Compass systems. This appeared to approximate the success rate of the July CPX, although, time did not permit a sufficient number of trials to establish a meaningful rate of success or failure. It did fail under moderate levels of bi-directional traffic.

d. The effect of the larger message at the TMC was favorable. The TMC was able to receive the message and to display and print it. Once it received the larger message, the CAMG template for its own free text message was enlarged to the size of the largest message received and it was also enabled to create the larger size message.

e. The Word Processing VFK in the Free Text Message format is designed to provide several other VFK selectable options for that purpose. It was found that selection of the Word Processing VFK caused the MCS to fail. The system would terminate MCS and return the user to the Main Menu every time. However, the basic Free Text Editor remains usable without the additional word processing features.

### **PART 3 SUMREP**

a. The SUMREP utilities required installation of a patch (/users/mcs/bin/mcs dated SEP 6) that was not included in the file system delivered in the tapes. It was not possible to produce distribution tapes for the 9 ID (MTZ) CPX CABER CALM that would include the patch without altering the existing system build. Further, time would not permit waiting to begin testing after a subsequent build could be sent from Leavenworth. Therefore, the system was tested without the benefit of the patch.

b. The SUMREP is designed to provide the user the capability to display a composite SITREP of all subordinate units (3 to a page). This function performs as required. However, the requirement that the report can be transmitted to a another system is not feasible without the patch. However, the existing capability provides the output of the required information product if the data is maintained on the local system.

**PART 4 TAPE COPY:** The tape copy system provides the user a utility to perform a copy from a source tape to a target tape. This utility was performed 24 times and was successful in each case.

**USER TRAINING CONSIDERATIONS:** The requirements for user training were evaluated concurrently with each part of the experiment. The improved file transfer utilities are transparent to the user and have no impact on training. The use of the Free Text Message format requires no new procedures, other than that the Word Processing VFK not be used. The SUMREP procedures are similar to those already in place for the SITREP and are quite intuitive. The Tape copy will not be required in the CPX, therefore, the issue of training is considered to be of minimal impact. A brief information paper and on-site orientations can provide the necessary assistance to the user.

**ENCLOSURE 2**

**OMNIBUS CPX CABER CALM TEST REPORT**

**(provided AES on 19 September 1989)**

**OMNIBUS**  
**CPX CABER CALM TEST REPORT**  
**MANEUVER CONTROL SYSTEM 10.02.1**

CPX CABER CALM provided an environment in which MCS 10.02 could be evaluated under realistic conditions. The system was used with packet-switching. The following items are identified as problems or issues associated with operation of the system in the CPX environment.

1. Problem: The SITDEF parameters are deleted as a result of receiving either a database replication or restoration. This result occurs with MCS 10.02.1 as implemented in 9 ID (MTZ) and with the patch installed.
  
2. Problem: File Transfer Utility is much improved; the relay problem identified in 10.02, Rev2 is fixed. However, other problems remain. MCS continue to become disabled by loss of communications (operator alerts 115, 132 and 134 are often displayed at these times) or by loss of keyboard control: Selector box is moveable but selections can not be made. Only the IBP and DOS utilities remain usable. This appears to result from files remaining open from previous file transfers; thus, no file descriptors available. This problem is not related to use of IPSE or DCIUs; it can be replicated with 2 TCPs using standard channel codes, linked by PCIUs with 2-wire or 4-wire cable.
  
3. Problem: Use of multiple address lists, with more than 4 addressees, produces high rates of transmission aborts. The aborts occur at the sending TCP. Apparently, the relative order in the list for messages that abort is random. This problem requires additional testing by ADEA to determine:
  - a. Is problem on Wide Area Network, only?
  
  - b. Is this problem unique to the application in 9 ID (MTZ) where packet-switching vs circuit-switching is used?
  
  - c. Are there other related conditions that contribute to the failure?

4. ISSUE: Change to MCS10.02.1 included new data management structures that made the version incompatible with backups of MCS Operational Files or MCS Databases from earlier systems. It is recognized that such changes will continue to be necessary in order that MCS can continue to mature as a system. Yet, such changes produce a host of problems in the user's sector. A solution may be to provide users with a conversion program that will convert old back up files into current data management structures.

**ENCLOSURE 3**

**OMNIBUS OUTLINE TEST REPORT FOR MCS 10.02.1**

**(provided AES on 26 September 1989)**

**Enclosure 3**

**OMNIBUS**  
**OUTLINE TEST REPORT**  
**MANEUVER CONTROL SYSTEM 10.02.1**

**GENERAL:** This report describes the Omnibus test activity focused on the File-Transfer and Multiple Address List utilities included in the current version of the MCS. The test was performed in 2 segments: one using a purely MCS environment and the other including the use of packet-switching with the IPSE. An overview and the basic conclusions are described next. The Executive Summary will cover the tests, beginning with: MCS LAN (Local Area Network) testing; MCS WAN (Wide Area Network) testing and finally; the WAN supported by packet-switching (IPSE). The observations made with the system in the 9 ID (MTZ) CPX CABER CALM are included in a separate section at the end of this report

EXECUTIVE SUMMARY

MCS LAN:

(1) The LAN was organized with addresses assigned as depicted in the Figure 1.

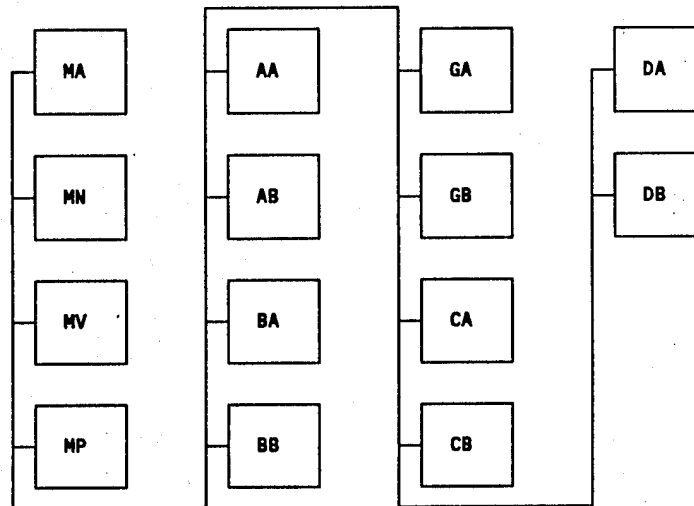

Figure 1 - LAN

(2) The File Transfer and Multiple Address List utilities performed well in a LAN-only environment. Text files were transmitted individually or by use of Multiple Address Lists of from 2 to 12 addressees. The text files used throughout the testing were created in the Integrated Business Package Word Processor. Three files of different sizes were used:

- "1\_page" - one text page, 3887 bytes
- "5\_page" - five text pages, 20983 bytes
- "10\_page" - ten text pages, 42353 bytes

(3) All file transfers were originated at a single system (MA) without other data activity on the LAN. There were no aborted messages observed in this portion of the test.

(4) As a final test, file transfer messages were forced to abort by sending file transfers to a "dummy" system (an address assigned as "XX" that was not an actual system). Up to 12 such aborted messages were accrued with no apparent effect on subsequent capability to perform file-transfer actions.

MCS WAN:

(1) The WAN was organized with addresses assigned as depicted in the Figure 1.

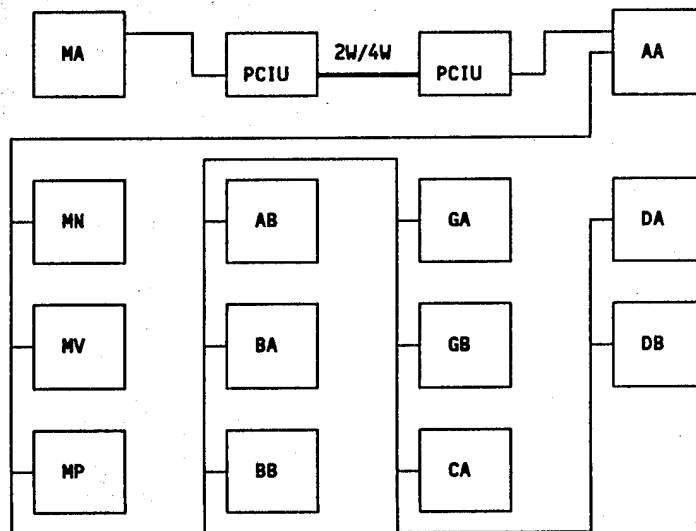

Figure 2 - WAN

(2) The network consisted of a TCP (MA), from which messages were generated, and a TCP connected by LAN (AA) to 11 ACs (See Figure 2). The 2 TCPs were connected by way of PCIUs with cable links. Standard MCS channel codes were also tested in different portions of the test with the corresponding cable configuration:

4W FSK-188C 1200 -6DB  
4W CDP 16000 -6DB  
2W FSK-188C 1200 -6DB  
2W CDP 16000 -6DB

(3) There were no aborted messages observed with three of the 4 channel codes; the 4W CDP 16000 -6DB produced a small number of aborted messages with one-way data flow. The level increased slightly with a low level of bi-directional traffic.

(4) File Transfer messages were forced to abort by sending file transfers to a "dummy" system (an address assigned as "XX" that was not an actual system). After each aborted file transfer, a file transfer would be executed to one addressee or with a multiple address list including up to 12 addressees. When a total of 8 aborted file transfer messages were accrued during a single working session in MCS, no further file-transfer actions were possible. The system could recover only if the user exited from MCS and then re-initiated work by reentering MCS. It must be emphasized that this result came only from aborted file-transfer messages. Eight or more aborted free text messages appeared to have no effect on subsequent file transfer activity.

(5) The inability to continue file transfer activity as described above was not always apparent. The transmission attempts, after 8 aborts had been forced, would appear successful at the sending and at the relay TCPs; output queues would ultimately decrement to "0". At the receiving nodes, the message header would occasionally indicate that the file transfer was not complete. But in most instances, it would appear as if the transfer was successful until the user retrieved the file in IBP; it would contain no data. Examination of the file size data showed that the size varied on a successful file transfer from one that was not successful. Essentially, the file size would be slightly larger. For example the 1 page text file would appear as 4704 bytes in the file system of the receiving system at the beginning of the transfer process. At completion of a successful transfer, the file size would change to 3887 bytes, the same as the source file. If the transfer was unsuccessful, the size remained at 4704 bytes. The console error "xmit\_temp cannot create" is also displayed within the shell when the transfer is unsuccessful.

(6) Free text messages are not effected by the this condition. With 8 accrued aborts of either free text or file transfer messages, successful free text transmission remained possible. There were no test efforts performed, however, to determine if other types of aborted messages would produce similar results. And no effort was taken to determine if messages other than free text may be impeded by the accrual of 8 aborted messages.

PACKET SWITCHING:

(1) The packet-switching segment of the test was performed with 4-Wire High Speed channel code with the following options:

```
OLD NAME: 4W CDP 16000 -6DB      NEW NAME: 4W CDP 16000 IPSE
-----
CHANNEL CONFIGURATION
DEVICE..... 4-WIRE
MODULATION..... COND DIPHASE
DATA RATE..... 16000 BPS
OUTPUT LEVEL..... 00B
KEY LENGTH..... 0.1 SECONDS
STOP BITS.....
PARITY.....
LINE TYPE.....
COMM NODE SELECTOR CONTROL.....
WAIT CLEAR CHANNEL.....
DELAY AFTER CLEAR..... SECONDS
PROTOCOL..... MCS
CIPHER MODE.....
ERROR CONTROL..... EDC AND TDC
NUMBER OF RETRIES..... 3
RETRY INTERVAL..... 30 SECONDS
TRANSMISSION FORM..... ABRIDGED
```

(2) The files transferred and the methods of testing for performance with packet-switching were the same as for the MCS WAN test segment described above. Failure of file transfers occurred once 8 aborted file transfer messages had been observed.

## OBSERVATIONS FROM 9 ID (MTZ) CPX CABER CALM

CPX CABER CALM: The CPX provided an environment in which MCS 10.02.1 could be evaluated under realistic conditions. The system was used with packet-switching. The following items are identified as problems or issues associated with operation of the system in the CPX environment.

(1) Problem: The SITDEF parameters are deleted as a result of receiving either a database replication or restoration. This result occurs with MCS 10.02.1 as implemented in 9 ID (MTZ) and with the patch installed.

(2) ISSUE: Change to MCS10.02.1 included new data management structures that made the version incompatible with backups of MCS Operational Files or MCS Databases from earlier systems. It is recognized that such changes will continue to be necessary in order that MCS can continue to mature as a system. Yet, such changes produce a host of problems in the user's sector. A solution may be to provide users with a conversion program that will convert old back up files into current data management structures.

### CONCLUSIONS

File transfer operations will perform well until 8 aborted file transfer messages are accrued during a given working session in MCS. After 8 file transfer messages have aborted, for any reason, continued file transfer operations are not feasible until the user restarts MCS. File transfer on the LAN is not effected by this condition. Use of the list is not a relevant factor to the file transfer problem.