

(DRAFT)
TECHNICAL REPORT - STUDY/SERVICES
TRADEOFF STUDIES, SYSTEM REQUIREMENTS ANALYSIS,
SYSTEM DESIGN ANALYSIS
(Data Items A002, A005, A006)

Structured Systems & Software, Inc., 23141 Plaza Pointe Dr., Laguna Hills, California 92653-1425

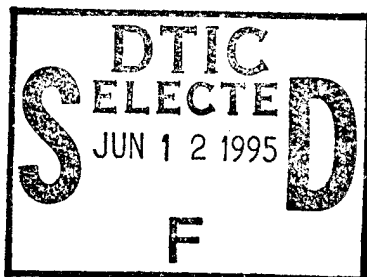

This document has been approved
for public release and sale; its
distribution is unlimited.

DTIC QUALITY INSPECTED 3

19950608 095

(DRAFT)
TECHNICAL REPORT - STUDY/SERVICES
TRADEOFF STUDIES, SYSTEM REQUIREMENTS ANALYSIS,
SYSTEM DESIGN ANALYSIS
(Data Items A002, A005, A006)

GPS/GLONASS STUDY
CONTRACT DAAL02-91-C-0089

92-41B1-003
January 31, 1992

Accession For	
NTIS CRA&I	<input checked="" type="checkbox"/>
DTIC TAB	<input type="checkbox"/>
Unannounced	<input type="checkbox"/>
Justification	
By <i>form 50</i>	
Distribution /	
Availability Codes	
Dist	Avail and/or Special
<i>A-1</i>	

Prepared for:
U.S. Army Harry Diamond Laboratories
2800 Powder Mill Road
Adelphi, Maryland 20783-1197

DTIC QUALITY INSPECTED 3

Prepared by:
Structured Systems & Software, Inc.
23141 Plaza Pointe Drive
Laguna Hills, California 92653

1.0 INTRODUCTION

This technical report presents interim results for the GPS/GLONASS study, contract number DAAL02-91-C-0089. Specifically, the results of tasks 1 through 3 , GPS/GLONASS Research and Tradeoff Analysis, System Requirements Analysis, and System Design Analysis are addressed.

2.0 GPS/GLONASS RESEARCH AND TRADEOFF ANALYSIS

A tradeoff is performed between a GPS-only versus a GPS/GLONASS capability.

2.1 Suitability to Tracking.

2.1.1 Receiver

A receiver capable of operating with both the GPS and GLONASS satellites is not currently available in an off-the-shelf configuration. Several manufacturers, including 3S Navigation, are developing such receivers, but their availability in a size and cost comparable to GPS equipment is still two to five years away. There is no insurmountable obstacle to achieving these size and cost objectives. A GPS/GLONASS receiver would require the same processing horsepower as a GPS-only receiver. Given the proximity of the frequencies involved, a single antenna can receive both systems' signals. The same synthesizer and front-end amplifier as for a GPS receiver can be used. The only major differences are the need for wider front-end filtering, a second IF section and a programmable second LO source to select desired satellites. We estimate that this translates into a 20 to 30 % increase in size, cost and power.

2.1.2 Availability of GLONASS

As was stated in the previous section, there is currently no off-the-shelf GLONASS receiver. Availability of the GLONASS constellation, i.e. whether the system will ever be fully deployed and the constellation maintained at a satisfactory level (especially in light of the current small average satellite lifetime expectancy of nine months versus the GPS seven years) is the subject of intense debate. Economic considerations alone might dictate a slow deployment. There are, however, several additional considerations, including:

a. a keen European and a developing Japanese interest in a less-than-full dependence on a system controlled by the US DoD;

b. a realization that the GLONASS augmentation of GPS would go a long way toward providing an acceptable level of system integrity, the lack of which is a major objection to universal acceptance of GPS, especially for mission-critical applications such as aircraft navigation;

c. strong, unambiguous statements made by Russian representatives at the December 30 meeting at Minsk committing to deploying the GLONASS system by 1996 and making it available for at least 15 years.

2.1.3 Spoofing Potential

A spoofer typically duplicates the signal broadcast by a satellite, introducing sufficient ranging error to lead to an erroneous position solution by the user. As such, and to be effective, it needs to spoof most if not all satellites which could be selected by a user in the target area. Clearly, then, a GPS/GLONASS capability which would double the constellation, would lead to a much reduced spoofing susceptibility.

2.2 Potential Advantages to Dual System

2.2.1 Faster Acquisition Time

Advantages include a faster acquisition time in the cold start mode, as more satellites are visible at any given time and location, thereby increasing the probability of acquisition.

2.2.2 Better Coverage in Obstructed Environment

This is one of the primary advantages of the dual implementation. Especially for the applications considered here, where it is essential that tracking be continuous even when surrounded by buildings, trees or mountains, the increased constellation will greatly enhance operational capability.

To this end, computer simulations were performed to quantify this advantage. The fully deployed 24-satellite constellations were used for both the GPS and GLONASS systems. Visibility and Position Dilution of Precision (PDOP) plots were generated for several mask angles and locations.

The ARINC SEM35 software was used to generate the data. The primary high altitude 24 satellites GPS constellation almanac, provided with the software was used. Almanac for the full 24 satellites GLONASS constellation was generated by 3S Navigation based on published descriptions of the GLONASS system.

Three locations were chosen:

- a. High latitude (Alaska): 70° N, 150° W
- b. Mid latitude (Adelphi): 40° N, 77° W
- c. Zero latitude (Ecuador): 0° , 80° W

Mask angles were: 5, 15, 30, 45, and 60 degrees.

To compare GPS and GLONASS characteristics, plots of satellite visibility as well as PDOP were generated for the 3 locations and 5 mask angles and for a period of 24 hours. They are included in Appendix A for the 5 and 15 degrees mask angles.

The following observations were made concerning the two constellations:

a. For low mask angles, 5 and 15 degrees, GPS visibility is better at high and low latitudes than at medium latitudes, with the better geometry (PDOP) at the low latitudes. GLONASS offers better visibility at the high latitudes and geometry is about the same at all latitudes.

b. For medium mask angles, 30 degrees, GPS visibility does not vary significantly with latitude, but the best PDOP is obtained at the mid-latitudes. GLONASS still offers more visibility at high latitudes, and for these mask angles PDOP is also clearly better at the high latitudes.

c. For high mask angles, 45 and 60 degrees, GPS offers better visibility at the mid latitudes while GLONASS still shows better characteristics at the high latitudes.

Overall, it is clear that GLONASS favors the high latitudes, while GPS performance varies depending on the mask angle, with a slight advantage provided at the mid latitudes.

With these characteristics, one would expect an enhanced overall performance as well as a lesser dependence on latitude with the dual GPS/GLONASS system than with either system alone.

2.2.2.1 Dual Versus Single System Performance

Since the ARINC software can only accommodate 24 satellites per almanac file, it was not possible to evaluate the combined constellation over a full 24 hours period. Instead, a 3 hour segment, from 6 am to 9 am UTC was selected for our analysis. Mask angles of 30, 45 and 60 degrees were utilized. Lower mask angles would have required to reduce the time period further (as more satellites are visible) and the advantage of dual operation is more pronounced at medium and high mask angles, making them more interesting to study.

The following satellites were visible at least some time during the selected time period and were included in the almanac files generated for each case:

- a. For High latitudes: GPS: 1,2,5,8,11,13,20,22,23,24
GLONASS: 1,2,3,4,9,10,11,16,18,19,20,21
- b. For Medium latitudes: GPS: 1,2,3,5,11,12,15,23,24
GLONASS: 2,3,4,5,15,17,18,19,20
- c. For Low latitudes: GPS: 2,11,12,15,17,23,24
GLONASS: 3,4,5,6,14,15,18,19

Plots were generated for satellite visibility and PDOP at the three locations and for mask angles of 30, 45 and 60 degrees. Full GPS, full GLONASS, and dual GPS/GLONASS constellations were used. These plots are included in Appendix B.

The following observations were made regarding dual operation versus either GPS or GLONASS:

- a. As expected, the dual system improves visibility and reduces PDOP at all latitudes.

b. At 30 degrees mask angle, the dual system provides 6 to 10 satellites and smooth PDOP (4 to 6), versus 3 to 6 satellites and high (>10 with peaks) PDOP for either system alone.

c. At 45 degrees mask angle, the dual system provides 4 to 9 satellites and PDOP of 6 to 15 versus 1 to 4 satellites and no solution for either system.

d. At 60 degrees mask angle, the dual system offers 2 to 4 satellites and a usually poor solution versus 0 to 2 satellites and no solution for either system.

Although the capabilities of the dual system are not without limits, as shown for the 60 degrees mask angle, it is clear from the limited analysis performed here, that it does greatly enhance satellite visibility and to a lesser extent geometry, i.e. performance. Clearly, as mask angles increase, even the availability of additional satellites do not always improve accuracy, as good geometry, i.e. PDOP, requires spatially distributed satellites, i.e. both high elevation and low to medium elevations at evenly spaced azimuths. This explains the relatively small performance enhancement at 60 degrees mask angle, and the limited improvement at 45 degrees.

2.2.3 Improved Accuracy

Visibility and associated PDOP issues were addressed in the previous section. This section first addresses system accuracy at the measurement level. Position accuracy is then obtained by multiplying measurement accuracy by PDOP.

2.2.3.1 Measurement Accuracy

A pseudorange measurement error budget is presented for a GPS C/A code receiver in Table 2-1.

If one also factors in the Selective Availability (SA) contributions, the projected Standard Positioning Service (SPS) horizontal accuracy is 100 meters (2drms). This approximately leads to a 50 meters (1σ), and considering an HDOP of 2.0 we obtain a measurement accuracy of 25 meters.

A similar error budget is not available for the GLONASS system. An MIT Lincoln Laboratory paper (Ref.1) determined via measurement sampling and analysis that GLONASS measurement accuracy was 7 meters (1σ). Closer inspection of

the work done on this paper indicates that mean values (i.e. 50% probabilities) were used instead of the RMS values. A better estimate for the range accuracy would therefore be 8.75 meters, or about exactly the SPS GPS accuracy available without SA implemented.

TABLE 2-1. GPS C/A CODE MEASUREMENT ERROR BUDGET

<u>ERROR SOURCE</u>	<u>ERROR (METERS)</u>
Space/Control Clock error	3.05
Ephemeris	2.62
Iono Delay	6.40
Tropo Delay	0.30
Receiver Noise/ Quantization/ Channel Bias	2.44
Multipath	3.05
<u>R.S.S.</u>	<u>8.51 meters</u>

Since the likelihood of SA being discontinued is, at best, slim, the GLONASS measurement accuracy of 8.75 meters is quite attractive compared with the GPS measurement accuracy of 25 meters.

2.2.3.2 Dual Operation Accuracy Issues

The major software issue relating to dual GLONASS/GPS operations has to do with timing. Specifically, in a GPS-only or GLONASS-only configuration, all measurements include a receiver clock error with respect to either GPS or GLONASS time, whichever system is being used. As this error is common to all measurements, it will only affect the time estimate and not the position or velocity estimates.

In the case of dual operation, some measurements will include a receiver-to-GPS clock error, while others will

include a receiver-to-GLONASS clock error. Clearly, the relation between the GPS and GLONASS time references has to be known for accurate position accuracies to be achieved.

The following brief analysis clarifies the issue.

A GPS pseudorange measurement can be represented as:

$$PR_{GPS} = R + c(\delta t_{R_{GPS}} - \delta t_{SV_{GPS}}) + \delta_{atmos} + noise$$

where:

PR_{GPS} is a GPS PR measurement,

$\delta t_{R_{GPS}}$ is the receiver clock error with respect to GPS time,

$\delta t_{SV_{GPS}}$ is the GPS satellite clock error with respect to GPS time,

δ_{atmos} are the atmospheric delay errors (iono and tropo).

A GLONASS pseudorange measurement can be represented as:

$$PR_{GLN} = R + c(\delta t_{R_{GLN}} - \delta t_{SV_{GLN}}) + \delta_{atmos} + noise$$

with similar definitions for its components.

Any solution based on a combination of GPS and GLONASS measurements would require the determination of two receiver clock offsets, namely $\delta t_{R_{GPS}}$ and $\delta t_{R_{GLN}}$, instead of only one. Filter state vectors could be increased to include this additional unknown, requiring five measurements instead of four. Alternatively, if the GPS-to-GLONASS time difference relationship could be determined ahead of time, GLONASS (or GPS) measurements could be software corrected to the GPS (or GLONASS) time base, thereby negating the problem, i.e.

$$\begin{aligned} PR_{GLN} &\rightarrow PR_{GLN} + c(t_{GLN} - t_{GPS}) \\ &= R + c(\delta t_{R_{GLN}} - \delta t_{SV_{GLN}}) + \delta_{atmos} + noise \\ &\quad + c(t_{GLN} - t_{GPS}) \\ &= R + c(\delta t_{R_{GLN}} + t_{GLN} - t_{GPS} - \delta t_{SV_{GLN}}) + \delta_{atmos} + noise \\ &= R + c(t_R - t_{GPS} - \delta t_{SV_{GLN}}) + \delta_{atmos} + noise \end{aligned}$$

$$= R + c(\delta t_{R_{GPS}} - \delta t_{SVGLN}) + \delta_{atmos} + \text{noise}$$

Either way, this issue can be handled with limited effort.

GPS time is related to UTC(USNO), while GLONASS time is related to Moscow time or UTC(SU). As was shown in the work performed by Daly (Ref.2), the difference can reach several μ secs and is therefore extremely significant to overall dual mode accuracy. This work also showed that the relation between the two references can be measured and communicated to users in a timely manner to allow dual operation.

Another issue in the dual mode operation is the different ellipsoids used by the two systems, the World Geodetic Survey 1984 (WGS-84) ellipsoid for GPS and the Soviet Geocentric Coordinate System 1985 (SGS-85) for GLONASS. Since satellite data broadcast by GLONASS are in SGS-85 ECEF coordinates, whereas GPS ephemeris data and satellite position algorithms are based on WGS-84, the relationship between these two ellipsoids has to be clearly defined.

2.2.3.3 Overall Accuracy

The overall positioning accuracy can be obtained, in a statistical sense, by multiplying the measurement accuracy with the Position Dilution Of Precision (PDOP). In the previous section, it was shown that GLONASS measurement accuracy of 8.75 meters was achievable, whereas GPS accuracy with SA implemented would yield 25 meters accuracy.

Assuming a PDOP of 4.0, this leads to 35 meters (1σ) accuracy for GLONASS and 100 meters (1σ) for GPS.

The accuracy of the dual operation would depend on the combined effect of improved PDOP over either system alone, coupled with the reduced accuracy of GPS measurements versus GLONASS measurements, as well as the residual error in the estimate of the difference between time references.

The following analysis assesses the accuracy achievable in the dual mode of operation as compared to the GPS-only and GLONASS-only modes.

The relation between PR accuracy and position accuracy can be represented, in a statistical sense, as

$$\delta X = PDOP \cdot \delta PR$$

where

δX is the position accuracy
 PDOP is the position dilution of precision
 δPR is the PR accuracy

The PR accuracy depends on the accuracy of individual measurements. If some are GPS measurements and some are GLONASS measurements, the δPR expression is a combination of both accuracies, as follows:

$$\delta PR = (n_{gps} UERE_{gps} + n_{gl'n} UERE_{gl'n}) / N + n_{small} R_{clock} / N$$

where:

n_{gps} is the number of GPS measurements,

$n_{gl'n}$ is the number of GLONASS measurements,

$N = n_{gps} + n_{gl'n}$ is the total number of satellites tracked by the user, typically four,

n_{small} is the smaller of n_{gps} and $n_{gl'n}$,

$UERE_{gps}$ is the User Equivalent Range Error, i.e. the estimated accuracy of a GPS PR measurement,

$UERE_{gl'n}$ is the User Equivalent Range Error, i.e. the estimated accuracy of a GLONASS PR measurement,

R_{clock} is the error in the estimate of the difference between time references

The last term is needed in the dual mode since this error will also degrade position accuracy.

The criterion is then to minimize

$$PDOP (n_{gps} UERE_{gps} + n_{gl'n} UERE_{gl'n} + n_{small} R_{clock})$$

Assuming $N = 4$,

we get a criterion

$$C_1 = \text{PDOP}(n_{\text{gps}}(\text{UERE}_{\text{gps}} - \text{UERE}_{\text{gln}} - R_{\text{clock}}) + 4(R_{\text{clock}} + \text{UERE}_{\text{gln}}))$$

or

$$C_2 = \text{PDOP}(n_{\text{gps}}(\text{UERE}_{\text{gps}} - \text{UERE}_{\text{gln}} + R_{\text{clock}}) + 4 \text{UERE}_{\text{gln}})$$

for $n_{\text{gln}} \leq n_{\text{gps}}$ and $n_{\text{gln}} \geq n_{\text{gps}}$, respectively.

CASE I. GPS SA IMPLEMENTED

Let us assume the following values:

$$\begin{aligned} \text{UERE}_{\text{gps}} &= 25 \text{ meters} \\ \text{UERE}_{\text{gln}} &= 8.75 \text{ meters} \\ R_{\text{clock}} &= 3 \text{ meters} \end{aligned}$$

We obtain:

$$C_1 = \text{PDOP}(13.25 n_{\text{gps}} + 47)$$

$$C_2 = \text{PDOP}(19.25 n_{\text{gps}} + 35)$$

The criterion, for several values of n_{gps} is:

n_{gps}	C
0	35 PDOP
1	54.25 PDOP
2	73.5 PDOP
3	86.75 PDOP
4	100 PDOP

As the dual operation will usually provide a smaller PDOP than either of the two systems alone, PDOP can be assumed to be smaller for values of 1, 2 and 3. The full GPS approach is obviously the worst. Depending on the PDOP reduction from the full GLONASS system, achieved by using 1, 2 or 3 GPS satellites, these cases will be optimal.

Based on the results obtained in the previous section, we can assume the following representative values for PDOP for a medium mask angle (30 degrees) situation:

GPS-only : 10
 GLONASS-only: 10
 Dual GPS/GLONASS: 5

If we then use these values for the calculation of the criterion C, above, (using the same value of 5 for all dual operation modes, which is of course not strictly correct), we get:

n_{gps}	C
0	350
1	271.25
2	367.5
3	433.75
4	1000

From the above, we conclude that:

a. given the choice between GPS satellites with SA and GLONASS satellites, GLONASS is the better choice

b. the dual use of both systems improves accuracy further through reduced PDOP.

CASE II. GPS SA NOT IMPLEMENTED

Let us assume the following values:

$UERE_{gps} = 8.51$ meters
 $UERE_{gln} = 8.75$ meters
 $R_{clock} = 3$ meters

We obtain:

$$C_1 = PDOP(-3.24 n_{gps} + 47)$$

$$C_2 = PDOP(2.76 n_{gps} + 35)$$

The criterion, for several values of n_{gps} is:

n_{gps}	C
0	35 PDOP
1	37.76 PDOP
2	40.52 PDOP
3	37.28 PDOP
4	34.04 PDOP

Using the same PDOP values as for case I, we obtain:

n_{gps}	C
0	350
1	188.80
2	202.60
3	186.40
4	340.40

We conclude that:

a. Dual operation will always provide better accuracy as geometry improvement dwarfs residual clock errors.

b. If measurement accuracies are equivalent, improvement ratio is slightly less than PDOP ratio.

2.2.3.4 System Integrity

Integrity is a major obstacle for widespread acceptance of GPS (or GLONASS). In the case of operation with a single system, it can be tested by comparing an overdetermined solution using the various possible combinations to arrive at a solution. For example, in the case of five satellites, there are five combinations of four satellites. If one satellite is providing "bad" measurements, one of the five solutions will be good, whereas the other four will be poor, thereby pointing to the bad satellite. But this approach requires calculating many solutions, thereby putting an increased computational burden on the receiver processor.

An alternate approach would be to process all-in-view. This, with a combination of residual tests, would rapidly point to a bad satellite, without requiring the calculation of multiple solutions. This requires at least five and preferably more satellites in view at any given time. Either system alone cannot provide this under all but very optimal visibility conditions. The dual GPS/GLONASS implementation, with its doubled constellation, would provide a much better integrity capability.

2.2.4 Power Consumption

Power consumption would be increased with the dual implementation as compared to either system alone. But as stated in section 2.1, this increase should not exceed 20 to 30 % and should not be a driver in system implementation.

2.3 Tradeoff Issues.

Advantages and disadvantages of the dual GPS/GLONASS implementation versus GPS only are presented in Table 2-2. GPS and GLONASS characteristics affecting dual operation are presented in Table 2-3.

Table 2-2. GPS/GLONASS VS GPS ONLY

<u>ADVANTAGES</u>	<u>DISADVANTAGES</u>
* Better Accuracy due to:	* Slightly more complex Receiver
* Better Geometry	
* GLONASS unaffected by SA	* GLONASS future not secure
* Better Availability due to more satellites in view	* GLONASS not under US control
* Better Integrity with all-in-view implementation	* Unproven GLONASS Reliability
	* No available off-the-shelf hardware

Table 2-3. GPS VS GLONASS CHARACTERISTICS IMPACTING DUAL OPERATION

<u>SIMILARITIES</u>	<u>DIFFERENCES</u>
* Spread Spectrum Systems	* GLONASS: Frequency Division
* 24 satellites	GPS: Code Division
* Frequency Bands allowing use of a Single Antenna	* GLONASS: ECEF sat. data transmitted GPS: orbital parameters transm.
	* Different Geodetic Coordinate Systems
	* GLONASS Time related to UTC(SU), GPS Time related to UTC(USNO)
	* Different ranging Codes and Frequencies
	* GPS 1 day vs GLONASS 8 day Ground Track Period

3.0 SYSTEM REQUIREMENTS ANALYSIS

In this section, we identify the requirements necessary to accomplish the taggant mission.

3.1 Concept of Operation of Positioning/Transmitting Device

The logical elements of the Positioning/Transmitting Device are depicted in Figure 3-1. The positioning task is performed by a satellite-based radiopositioning system, GPS-only or GPS/GLONASS. When requested via the Position Transceiver, the Positioning subsystem turns on to full

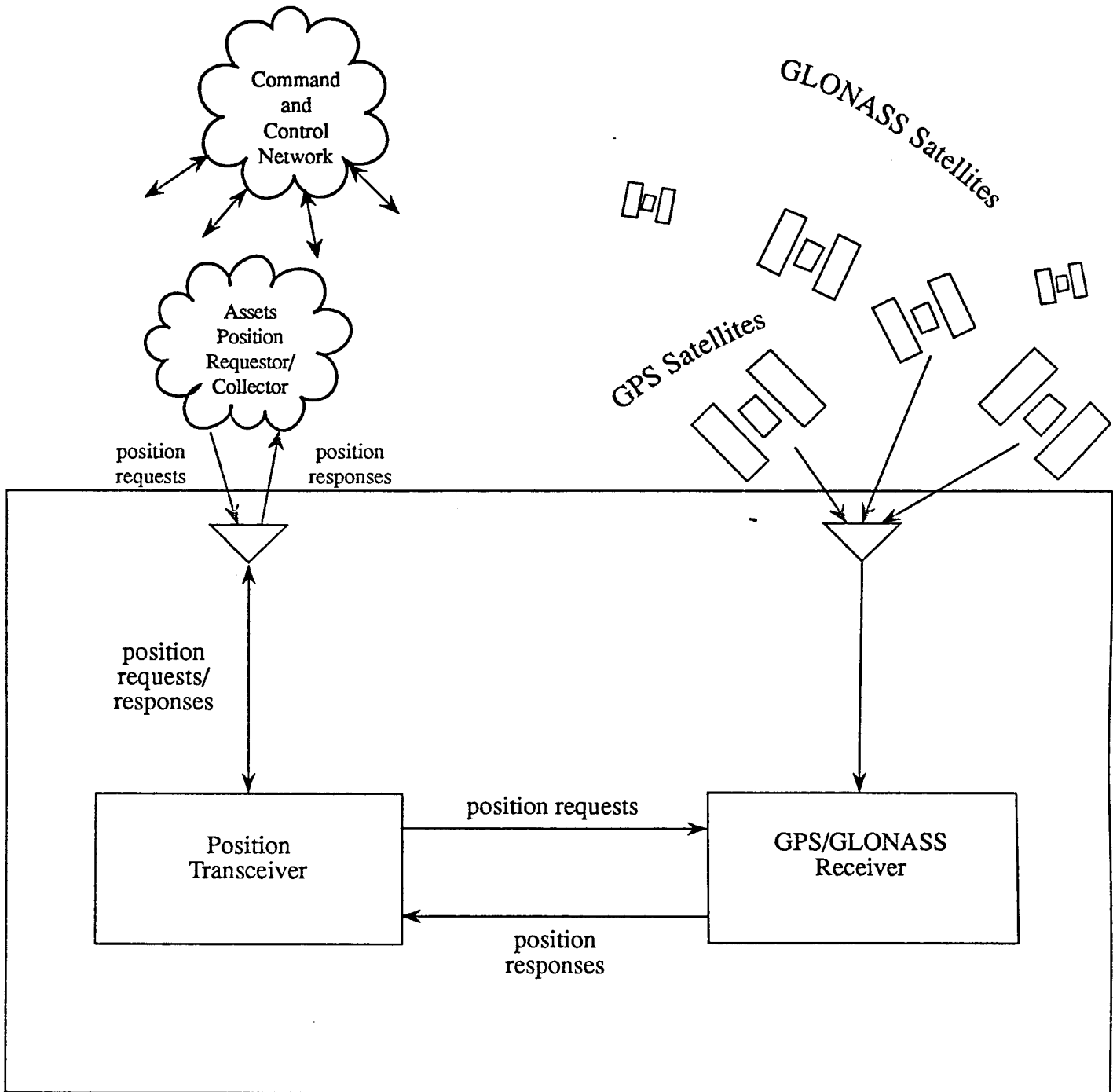

Figure 3-1 Logical Elements of Positioning/Transmitting Device

power, acquires the selected satellites and generates a position output, which is then broadcast to the requester by the transmitting subsystem. As part of the positioning request, the update period is provided to the positioning subsystem so as to allow the positioning device to reenter the quiescent mode between updates and only turning itself on as needed for the specified update period. This on-demand activation allows efficient power management, since the Device will draw minimal power while in the inactive mode.

A disadvantage of this approach is the need for the receiver to reacquire satellites for every update, as well as the filter settling time required for each solution. Unless update periods are smaller than one minute, the on/off approach described above is the preferred one. For shorter update periods, little is gained by it.

Requirements for the Positioning Subsystem are addressed in the following sections. The Transceiver subsystem is considered an off-the-shelf item with requirements driven by its intended mission, and beyond the scope of this study.

3.2 Large Scale Assets to be Tracked

There are several missions for the taggant:

- a. the tracking of a single vehicle engaged in legal (e.g. public safety vehicle) activities,
- b. the tracking of a vehicle or small group of vehicles engaged in illegal activities (e.g. drug runner),
- c. the tracking of a military formation. In this case, the tracked vehicle(s) could be cooperative or not.

Vehicles involved include ground, sea and air platforms, and cover therefore a wide range of dynamics. Positioning requirements for these vehicles vary and are addressed in the next section.

3.3 Positioning Requirements

Positioning requirements vary depending on the mission, the type of vehicle tracked (i.e. its dynamics), whether a

single vehicle or a formation is being tracked, the environment, i.e. rural or urban, open or concealed surroundings.

CLASS	DYNAMICS	ENVIRONMENT	ACCURACY	UPDATE
Single Ground	<100MPH <1 g	Urban	50 m	10 sec
Single Ground	<100MPH <1 g	Rural	150 m	30 sec
Single Air	<600MPH <5g	high/open space	150 m	10 sec
Single Air	<300MPH <5g	low/canyons	150 m	5 sec
Single Sea	<30 MPH <1 g	Open seas	150 m	30 sec
Single Sea	<30 MPH <1 g	river/swamps	50 m	10 sec
Formation Ground	<100MPH <1 g	Urban/forest	150 m	30 sec
Formation Ground	<100MPH <1 g	Rural/Open	300 m	60 sec
Fixed vehicle/ Container	0.0	All	150 m	300 sec

3.4 Other Requirements

Additional requirements include the ability to conserve power, as discussed in section 3.1, especially for non-cooperating targets where the taggant installation had to be concealed with the associated size and power limitations. This can be done by utilizing a remote turn-on for on-demand activation.

Easy installation is also important as it needs to be performed on a variety of platforms, often under life-threatening conditions. Size must be small as it must be

concealed. The required level of ruggedness depends on the specific application. Reception must be assured in various situations. Tracking in urban environments when surrounded by high buildings is difficult, and this is where the dual GLONASS/GPS implementation is most useful. Multipath needs to be controlled or utilized (for example, for an antenna mounted below a car bumper and receiving the satellite signals reflected from the ground).

4.0 SYSTEM DESIGN ANALYSIS

In section 2.0, tradeoffs between a dual GPS/GLONASS system and a GPS only system were discussed. From this analysis, it is clear that for all their similarities, there are significant differences between the GPS and GLONASS.

The frequency division multiplexing approach versus the GPS code multiplexing approach requires an antenna with a sufficiently broad bandwidth to accommodate both systems. Such antennas are available and do not present a problem. As the RF frequencies are different, different IF sections have to be developed. The different approach used by GLONASS for the broadcast of satellite data, as well as the differences in the remainder of the data transmission format and contents require the development of new software. The same is true for the reconciliation of the time references, as was addressed in the previous section.

The taggant positioning subsystem, if based on a dual GPS/GLONASS capability requires the development of a GPS/GLONASS engine meeting difficult size and power requirements. The basic dual capability is provided by the 3S Navigation R-100 receiver. The R-100 is described in the next section, followed by a discussion on the modifications necessary to meet the taggant requirements.

4.1 3S Navigation R-100 GPS/GLONASS Receiver

This receiver is developed for hosting on an IBM PC-compatible expansion board. A block diagram is presented in Figure 4-1. The R-100 allows for continuous, Nyquist-sampled, coherent tracking of GPS and GLONASS signals. Combined processing is tightly integrated, and individual satellite tracking channels can be assigned to any GPS or GLONASS satellite. The R-100 includes a broadband antenna, an RF/IF subsystem, and a GPS/GLONASS Digital

Signal Processor. Control is exercised via the PC host, utilizing either NMEA 0183 formatted commands or an interactive menu interface.

The R-100 continuously tracks up to 12 GLONASS or 6 GPS C/A code signals in the L1 band, or a combination of both. Additional expansion boards can be used to track more satellites.

Additional design details are discussed below and summarized in Table 4-1, R-100 GPS/GLONASS Receiver Configuration and Specification.

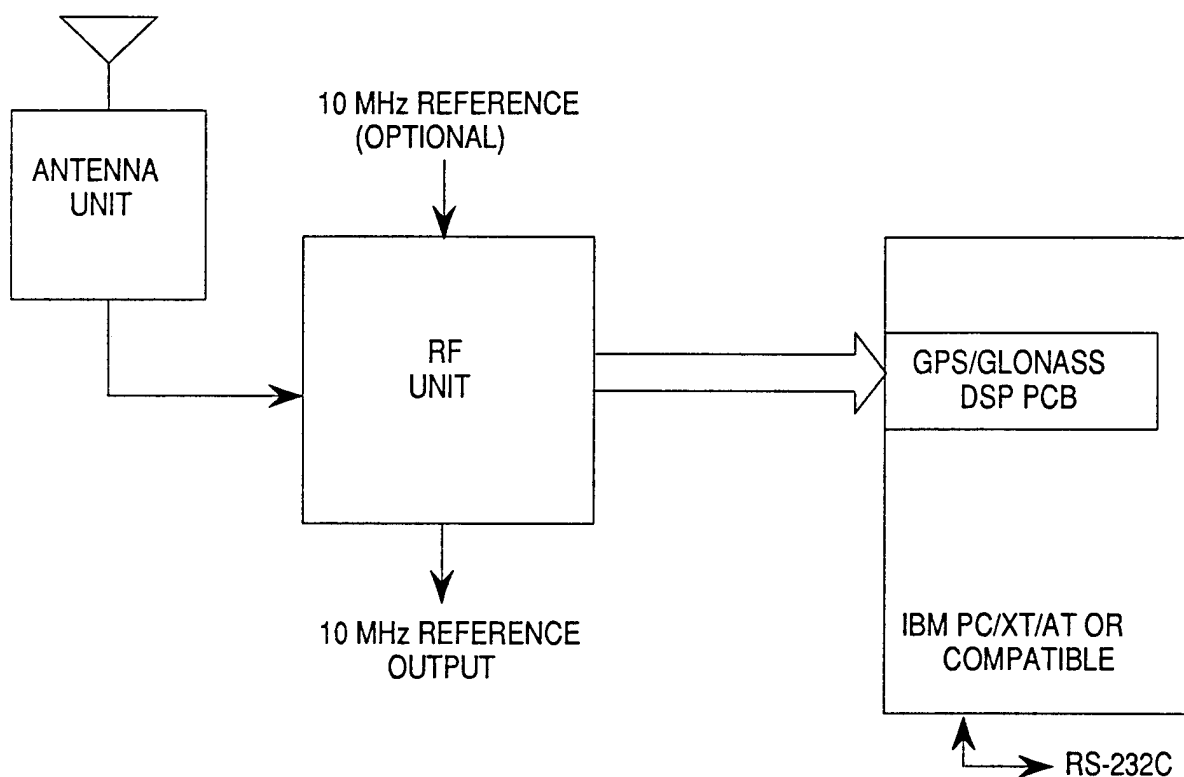

Figure 4-1. R-100 Functional Block Diagram

Table 4-1. R-100 GPS/GLONASS Receiver Configuration and Specification.

CONFIGURATION

Basic System	L1 Antenna/PreAmp Assembly L1 RF/IF Unit GPS/GLONASS Digital Signal Processor (plugs into IBM PC-compatible expansion slot) Host computer, IBM PC/AT-compatible Software on 3 1/2" diskette (pre-loaded on hard disk) Installation Guide and Users Manual
Portable Host (Optional)	Portable IBM PC/AT-compatible host computer
GLONASS Logging (Optional)	Bernoulli 90 megabyte cartridge disk drive added to host computer configuration. Logging software on 3 1/2" diskette.

SPECIFICATION

Receiver	Channels, combined GPS and GLONASS per the linear equation $a + 2b \leq 12$, where: <ul style="list-style-type: none"> a. up to 12 channels GLONASS C/A code, L1 frequency b. up to 6 channels GPS C/A code, L1 frequency All channels are continuous Nyquist-sampled, coherent tracking
GLONASS Logging (Optional)	GLONASS data messages compressed by removing repeating data bits that can be correctly modelled. Compressed data messages and measurements of pseudo range and delta range logged to Bernoulli 90 megabyte disk drive.
Performance	Accuracy: 35ft. (10 meters) RMS with PDOP <3 (Position) and no GPS Selective Availability. Accuracy: ± 200 ns RMS referenced to GPS time. GPS accuracy is reduced when Selective Availability is turned on.
Velocity	Up to 600 mph (960 km/hr)
Power Requirement	115 VAC
Mechanical Outline	Outline and connector layout of PC plug-in board enables installation in IBM PC XT/AT-compatible computers.

[more on reverse side]

Table 4-1. R-100 GPS/GLONASS Receiver Configuration and Specification. (Continued)

Overall Dimensions	13.25" x 3.75" x 0.75" PC plug-in board 17" x 10" x 1.75" RF/IF assembly 4" x 4" x 12" antenna/pre-amp assembly
Weight	NTE 30 lbs with portable PC host. NTE 50 lbs with standard PC host. NTE 60 lbs with standard PC host, Bernoulli disk drive.
Operation	Operation is via the host PC. A selection of utility programs on the PC enable access to the receiver.
Environmental	Temperature: As for host PC (operating) Storage: -25° to +85°C Humidity: 95% Antenna: -25° to 70°C
Interfaces	Data interface via PC bus connector. Antenna input is to RF/IF assembly. RF/IF output interfaced to PC plug-in board via cable.
Timing	Timing (1 pulse/sec) output referenced to GPS (time). Timing output via rear panel BNC connector. Time resolution ± 60 ns.
Antenna	Upper hemispherical coverage, right hand circularly polarized. Integral preamplifier/filter.
Manuals	Installation Guide and Users Manual.

4.1.1 Antenna/Preamp Assembly

A circularly polarized L1 broadband marine-grade antenna was selected for the R-100. The assembly includes a preselection filter and low noise amplifier. It has sufficient gain to permit cable lengths of up to 100 feet.

4.1.2 RF/IF Unit

This unit amplifies and filters the RF signal, downconverts to various intermediate frequencies (IF), selectively amplifies the desired spectra, downconverts to near baseband, and digitizes in-phase and quadrature-phase samples at 17.5 MHz. The unit synthesizes its own 10 MHz reference frequency or accepts an external input.

4.1.3 Digital Signal Processor

This subsystem receives digital samples from the RF/IF Unit and performs continuous Nyquist-sampled tracking of multiple GPS and/or GLONASS satellites. It tracks phase and frequency errors due to clock drifts, satellite Doppler, receiver platform motion and thermal noise. It selects healthy satellites that provide best solution geometry. It also provides fast sequencing all-in-view tracking. Satellite almanac and ephemeris data are extracted from the satellite messages and transferred to the data processor for solution generation.

4.1.4 Data Processor and User Interface (PC Host Computer)

This subsystem provides receiver control and display capabilities. The navigation software computes filtered two- or three-dimensional position and velocity solution for all visible and/or healthy satellites. Various displays are available, as well as hard-disk storage of output data for post-processing.

4.2 Positioning Subsystem Design

Although the R-100 goes a long way towards providing the required positioning capability, it is not yet an off-the-shelf product, it is not autonomous (requires PC), it is fairly large and heavy (see Table 4-1), it requires 115 V.

Availability of a GPS/GLONASS engine meeting the taggant requirements is probably two to five years away.

No technological breakthroughs are needed to achieve this design, as similar engines are available for GPS and could be modified for dual GPS/GLONASS operation. But sizeable financial commitments are needed to attempt such a development. Given the current uncertain future of GLONASS as well as the potential availability of other GPS augmentation systems, most leading manufacturers are currently in a "wait-and-see" mode.

Additional required design features, including the remote turn-on for power management, the potential use of multipath signals reflected off the pavement to an antenna concealed below a car bumper need to be investigated as to their feasibility and/or practicality. The design impact of the requirements for concealed installation and operation, possibly leading to multiple configurations depending on the target vehicle, need to be addressed after these requirements have been specified by the users.

5.0 LIST OF REFERENCES

1. P. Misra & All, Integrated Use of GPS and GLONASS in Civil Aviation Navigation II: Experience with GLONASS, Proceedings ION GPS-91, Albuquerque, NM, September 1991
2. P. Daly & All, Satellite Time Transfer between UTC(USNO) and UTC(SU) Using Navstar GPS and GLONASS, Proceedings ION GPS-91, Albuquerque, NM, September 1991

6.0 APPENDICES

6.1 APPENDIX A.
RESULTS WITH GPS AND GLONASS FULL CONSTELLATIONS.
SINGLE SYSTEM OPERATION.

I. GPS-ONLY OPERATION FOR 24 HOURS

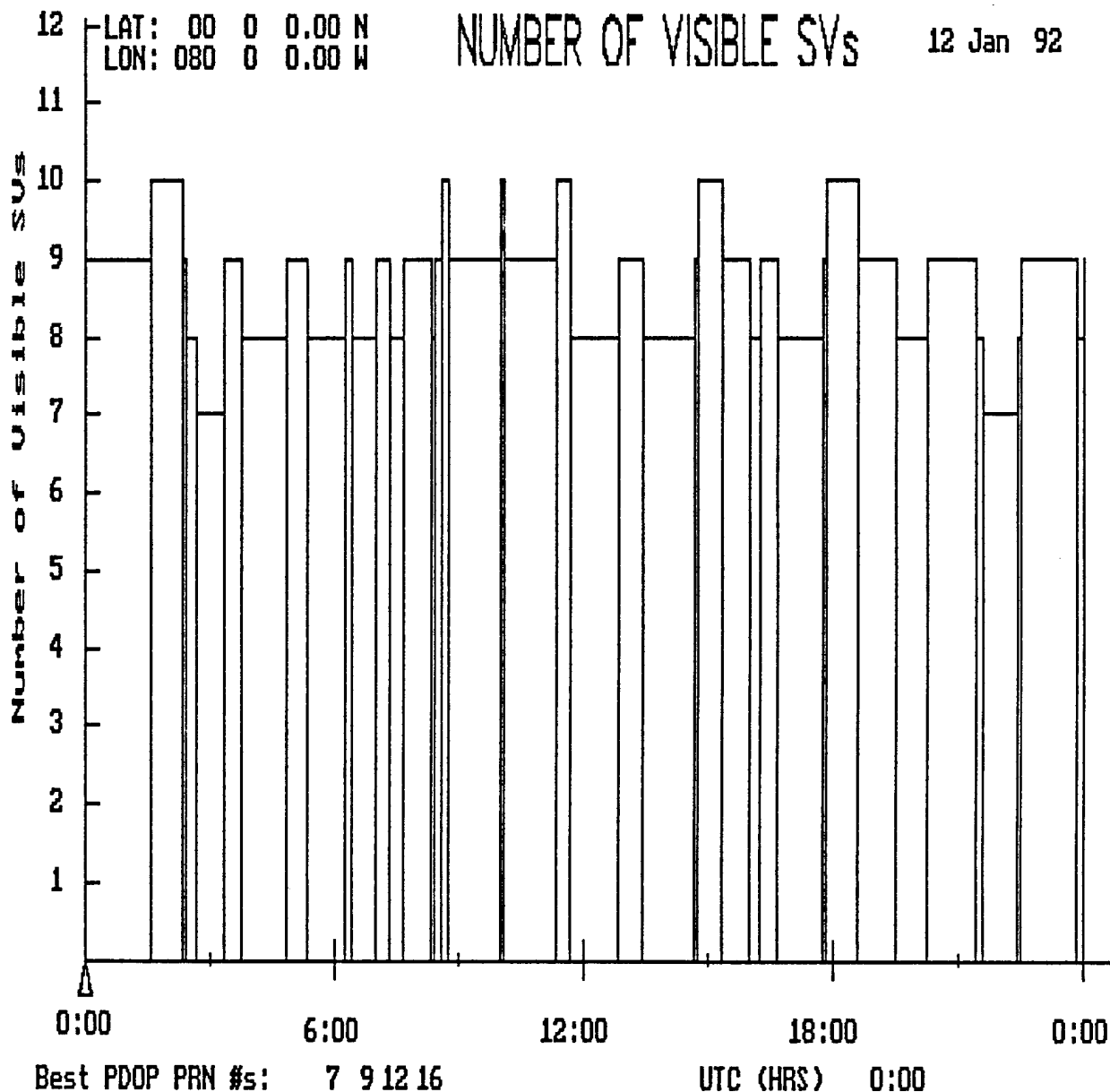

Figure A-1. Number of Visible GPS Satellites At Low-Latitudes. Mask Angle of 5 Degrees.

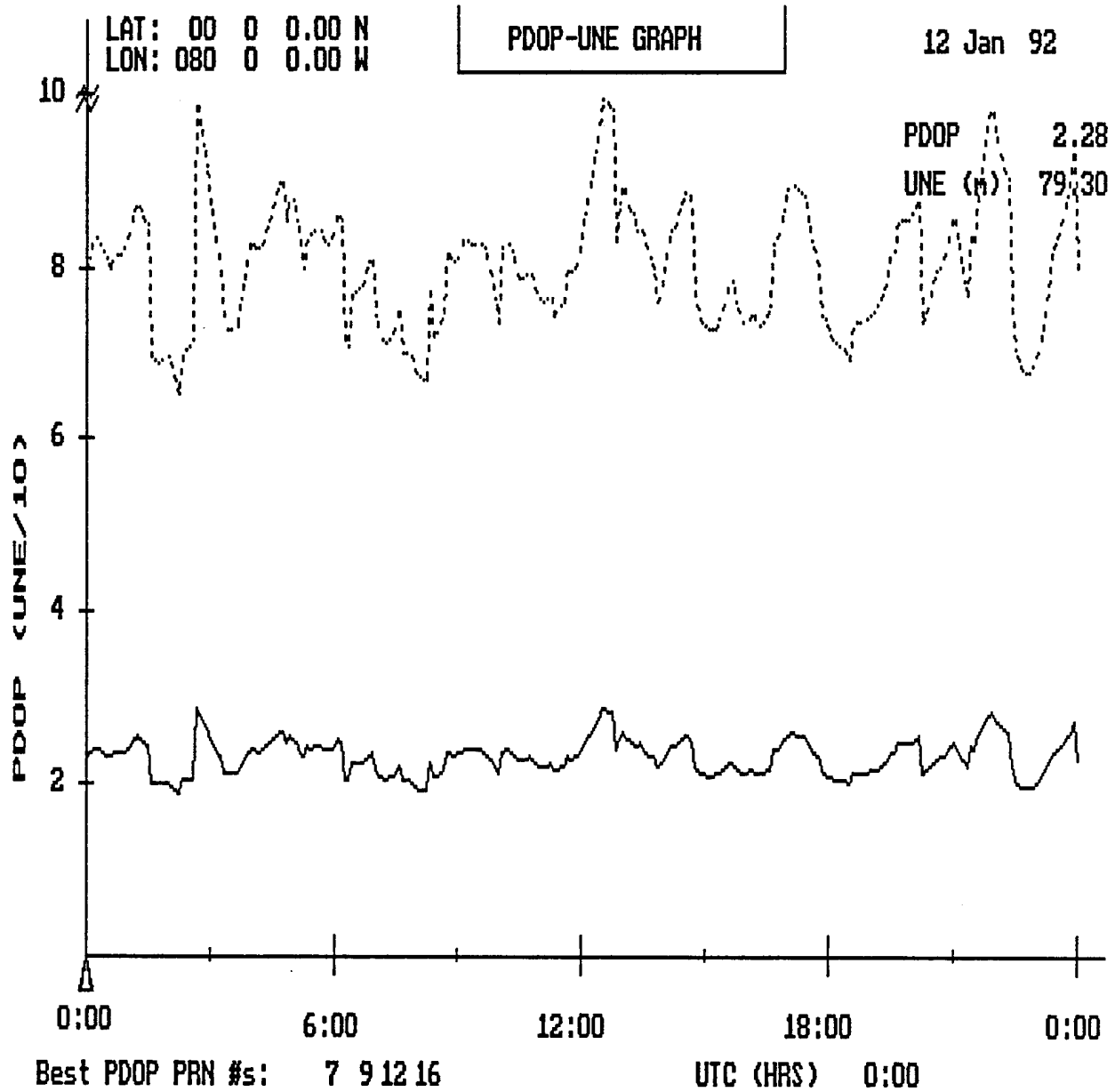

Figure A-2. GPS PDOP At Low-Latitudes.
Mask Angle of 5 Degrees.

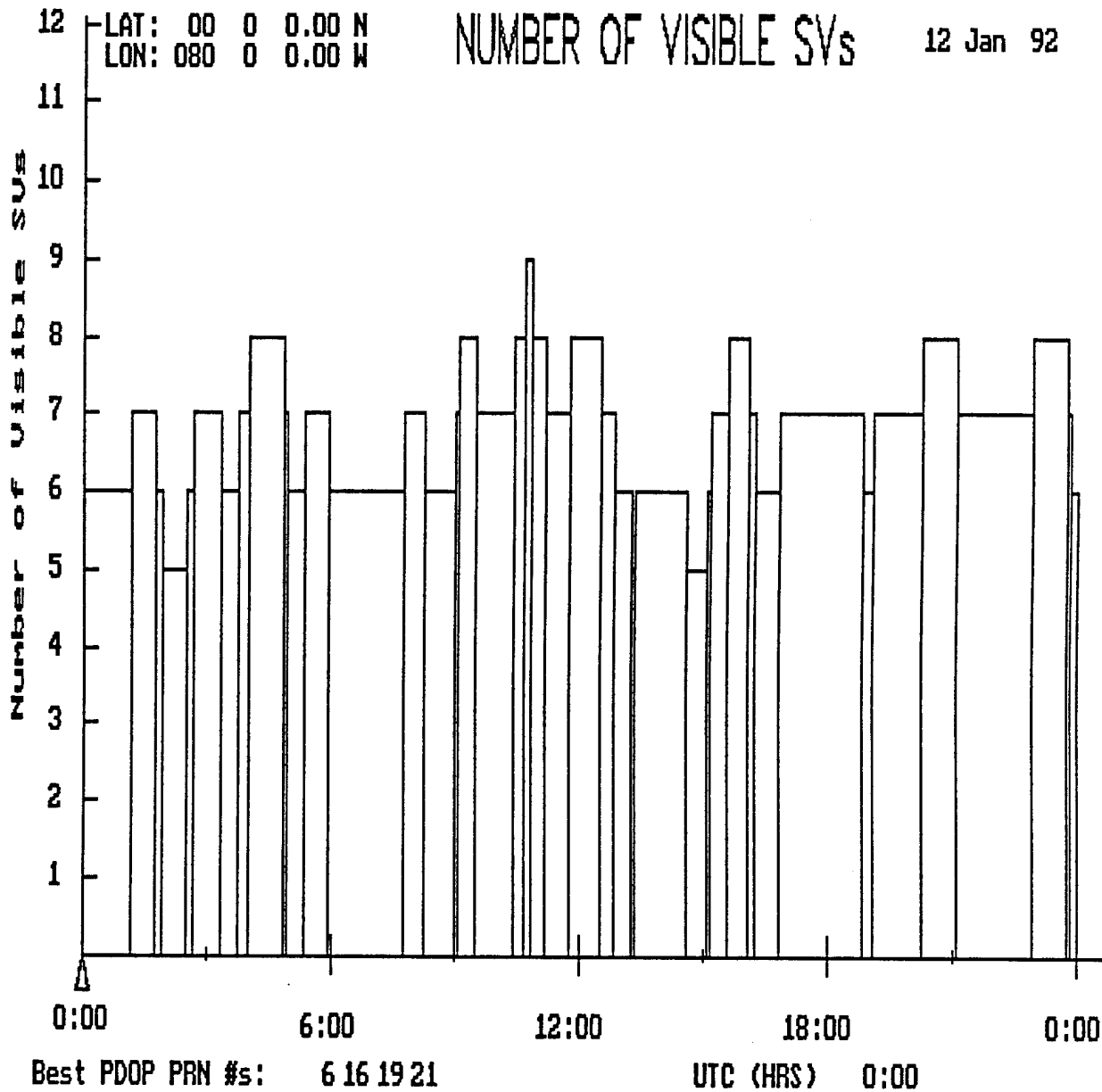

Figure A-3. Number of Visible GPS Satellites At Low-Latitudes. Mask Angle of 15 Degrees.

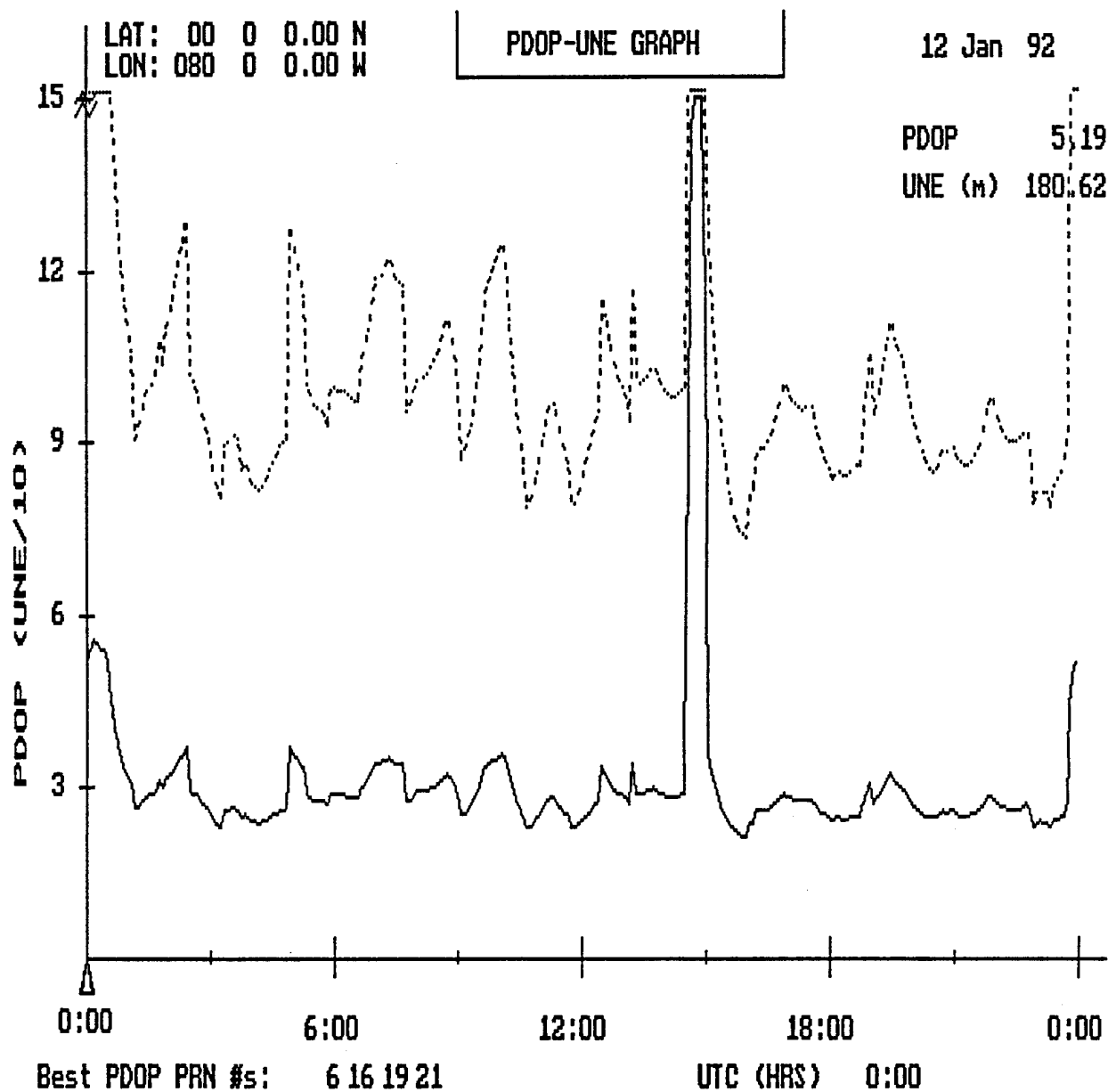

Figure A-4. GPS PDOP At Low-Latitudes.
Mask Angle of 15 Degrees.

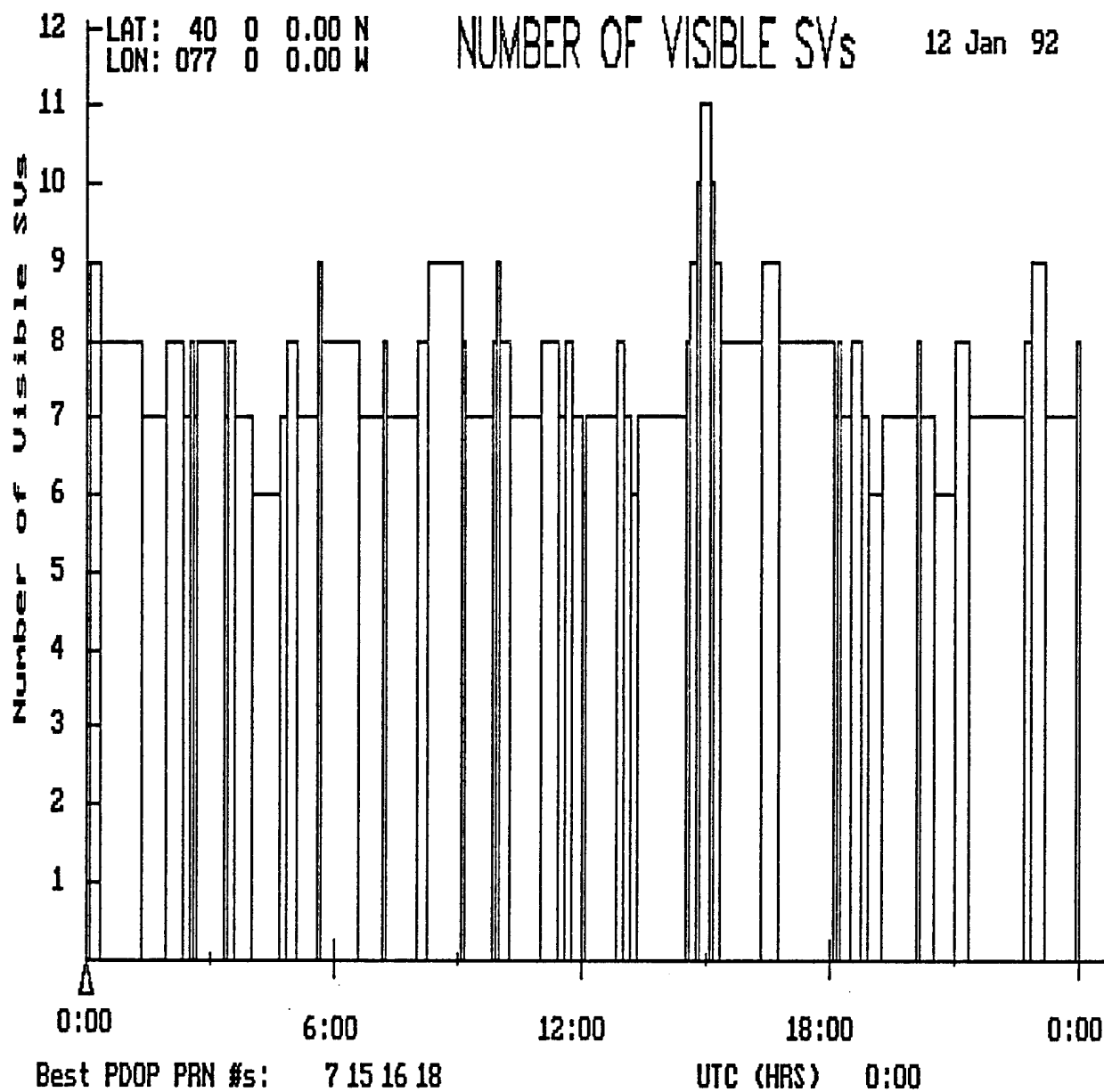

Figure A-5. Number of Visible GPS Satellites At Mid-Latitudes. Mask Angle of 5 Degrees.

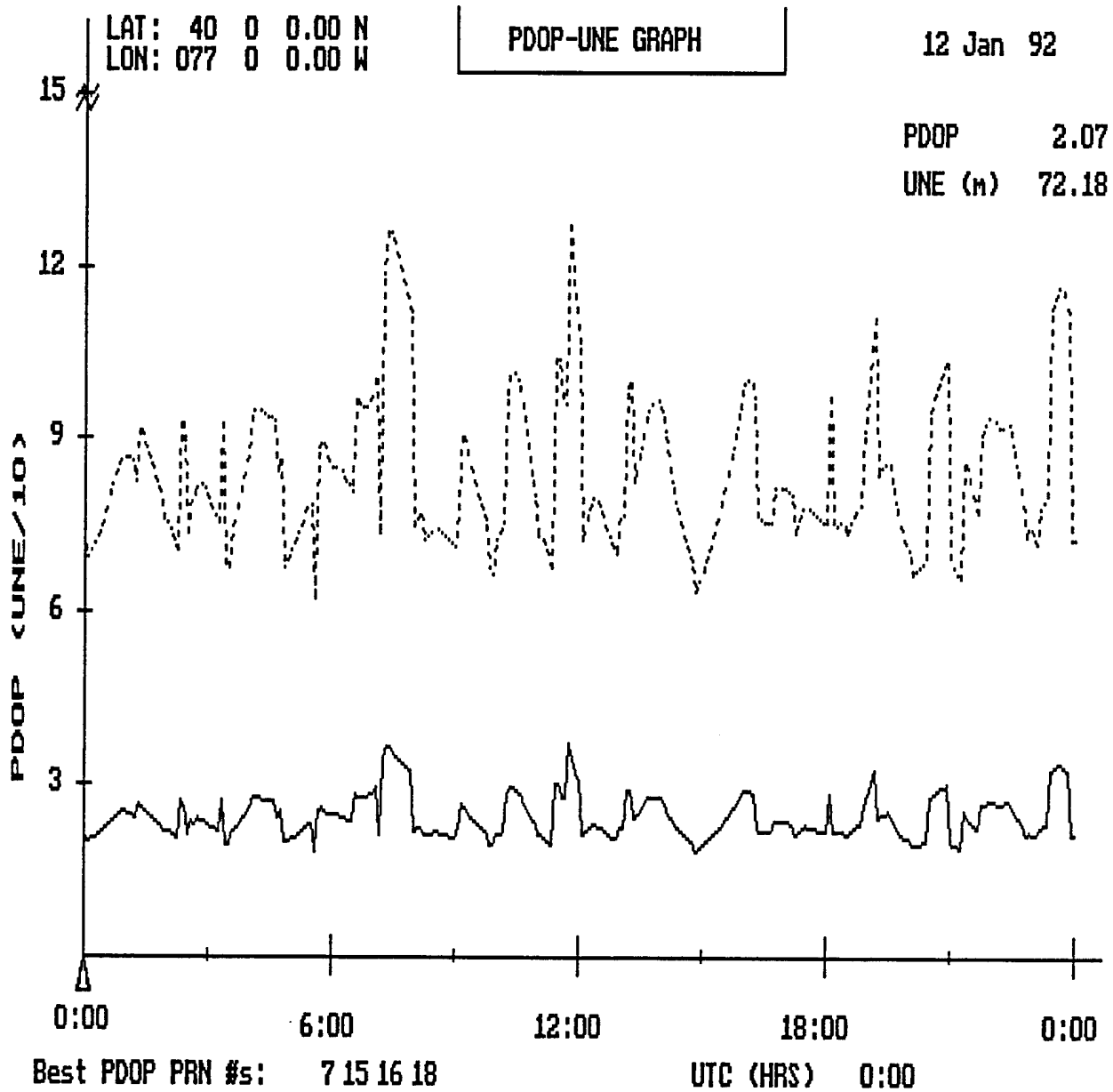

Figure A-6. GPS PDOP At Mid-Latitudes.
Mask Angle of 5 Degrees.

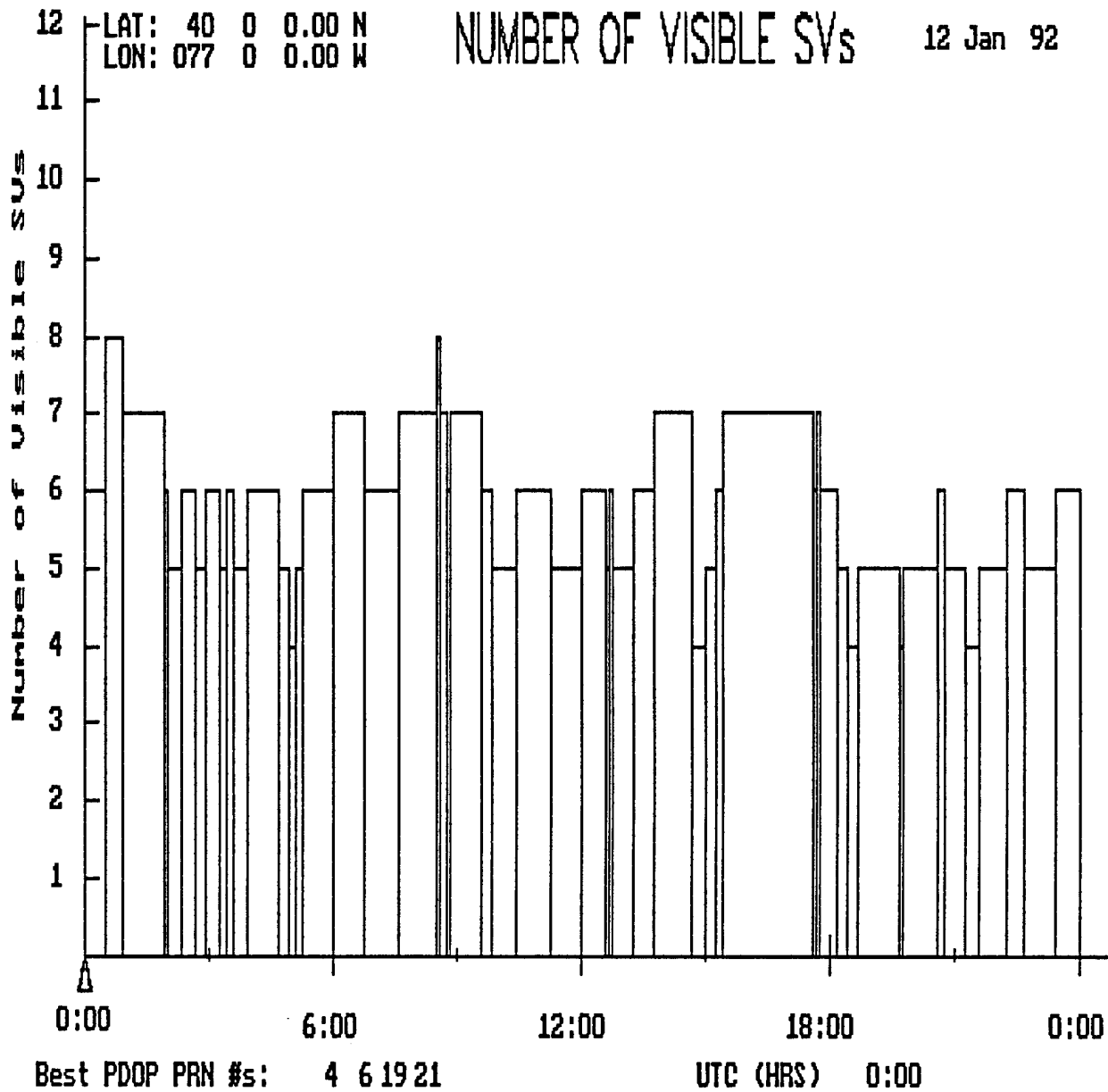

Figure A-7. Number of Visible GPS Satellites At Mid-Latitudes. Mask Angle of 15 Degrees.

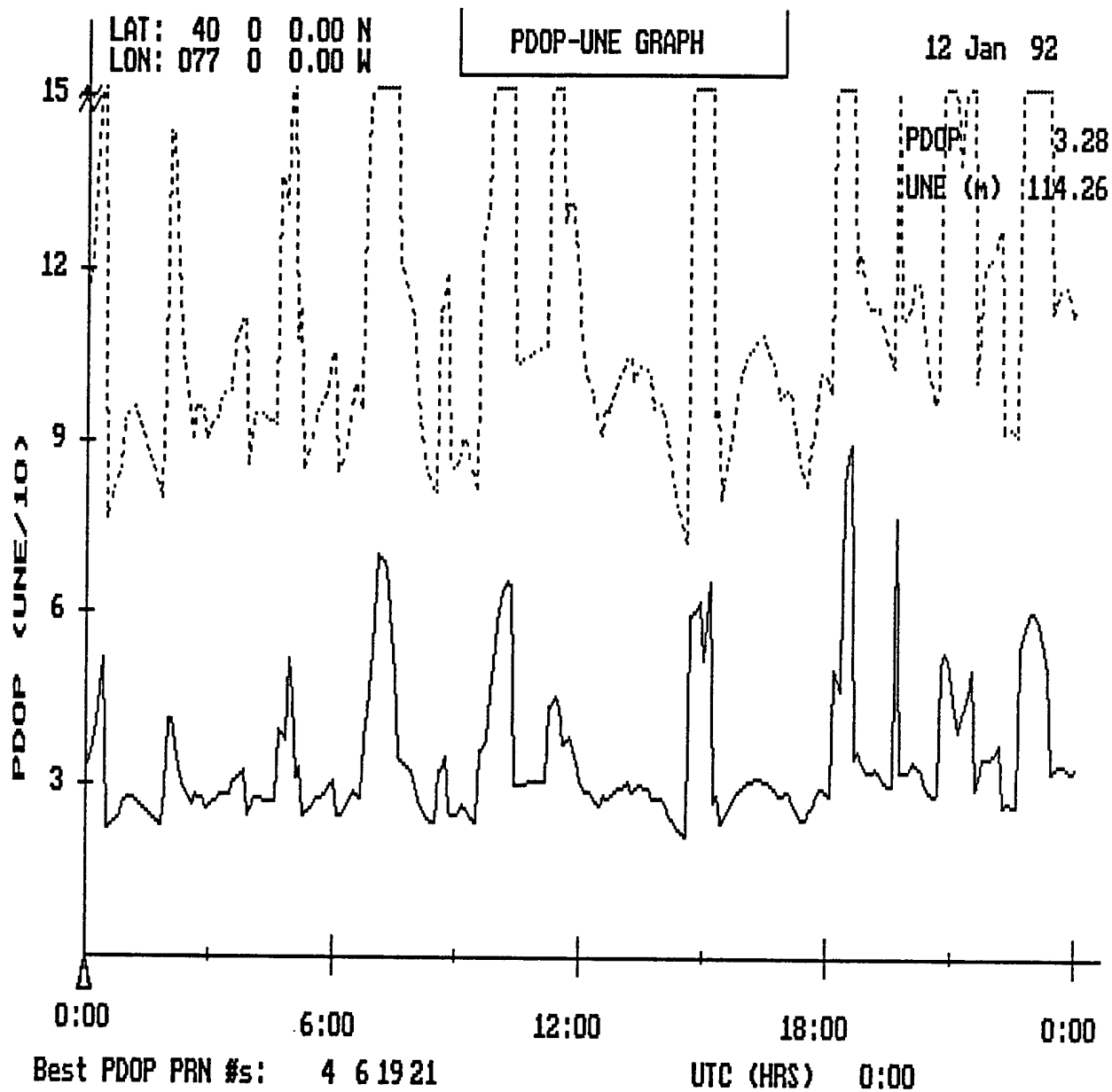

Figure A-8. GPS PDOP At Mid-Latitudes.
Mask Angle of 15 Degrees.

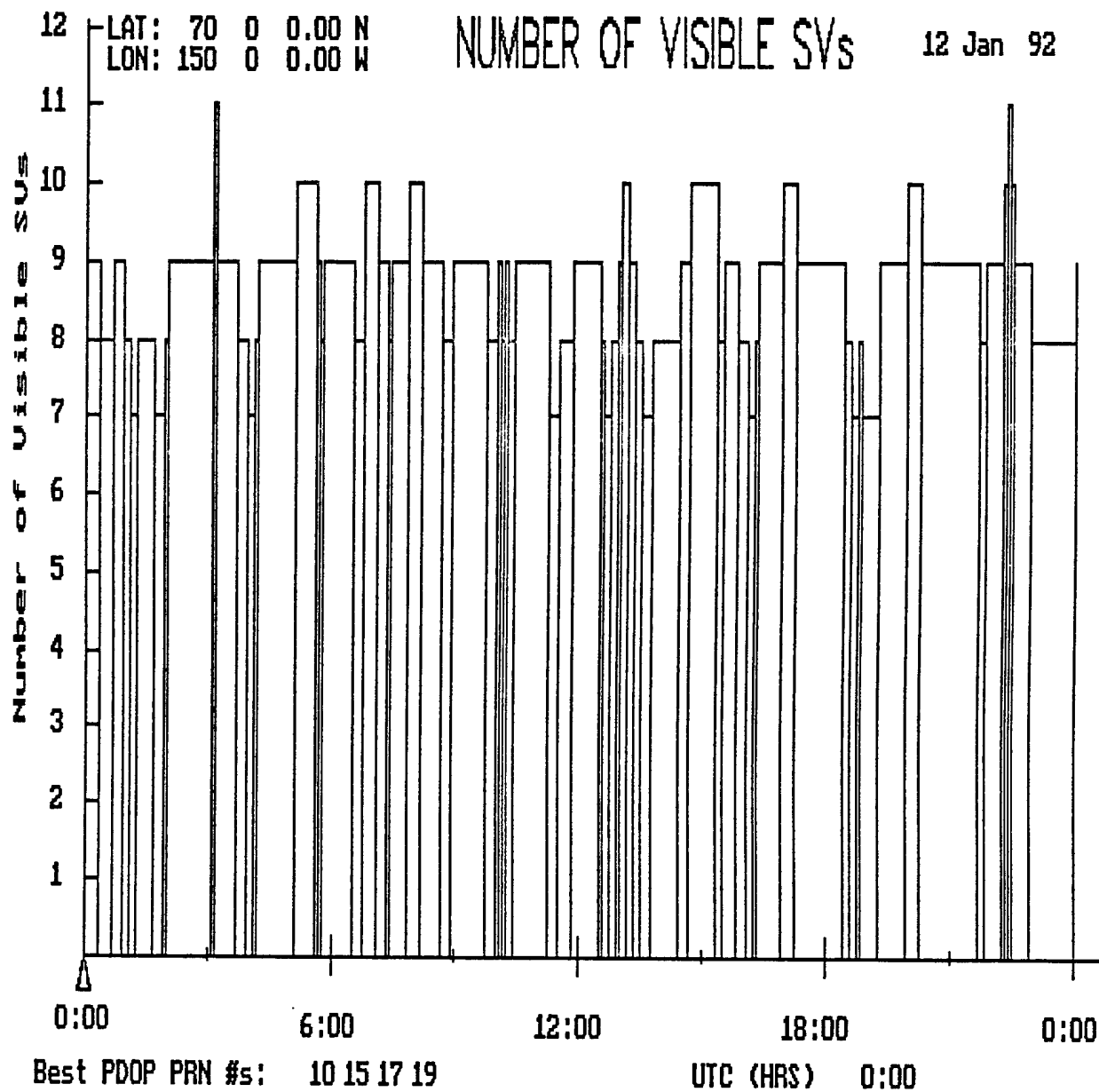

Figure A-9. Number of Visible GPS Satellites At High-Latitudes. Mask Angle of 5 Degrees.

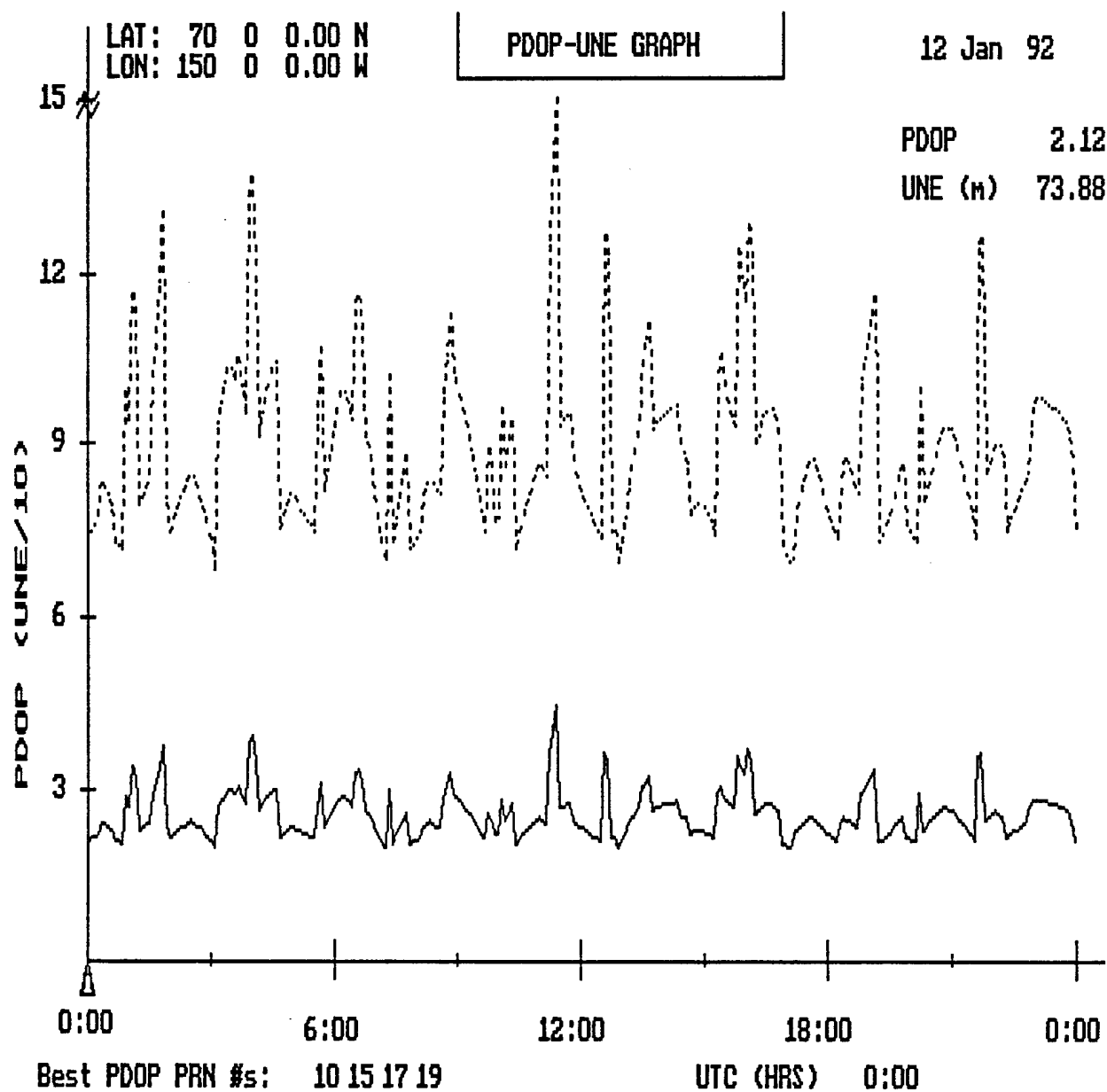

Figure A-10. GPS PDOP At High-Latitudes.
Mask Angle of 5 Degrees.

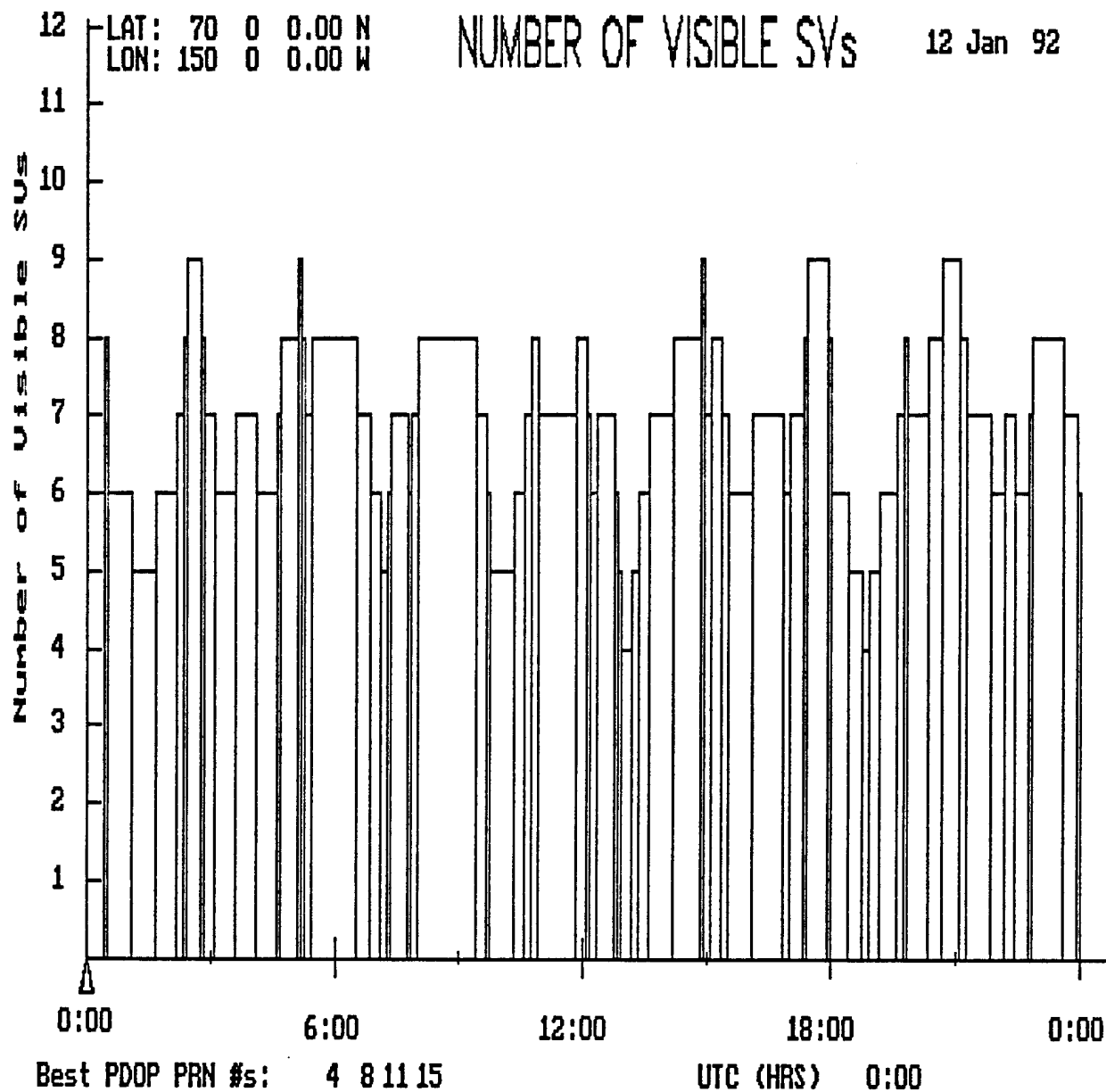

Figure A-11. Number of Visible GPS Satellites At High-Latitudes. Mask Angle of 15 Degrees.

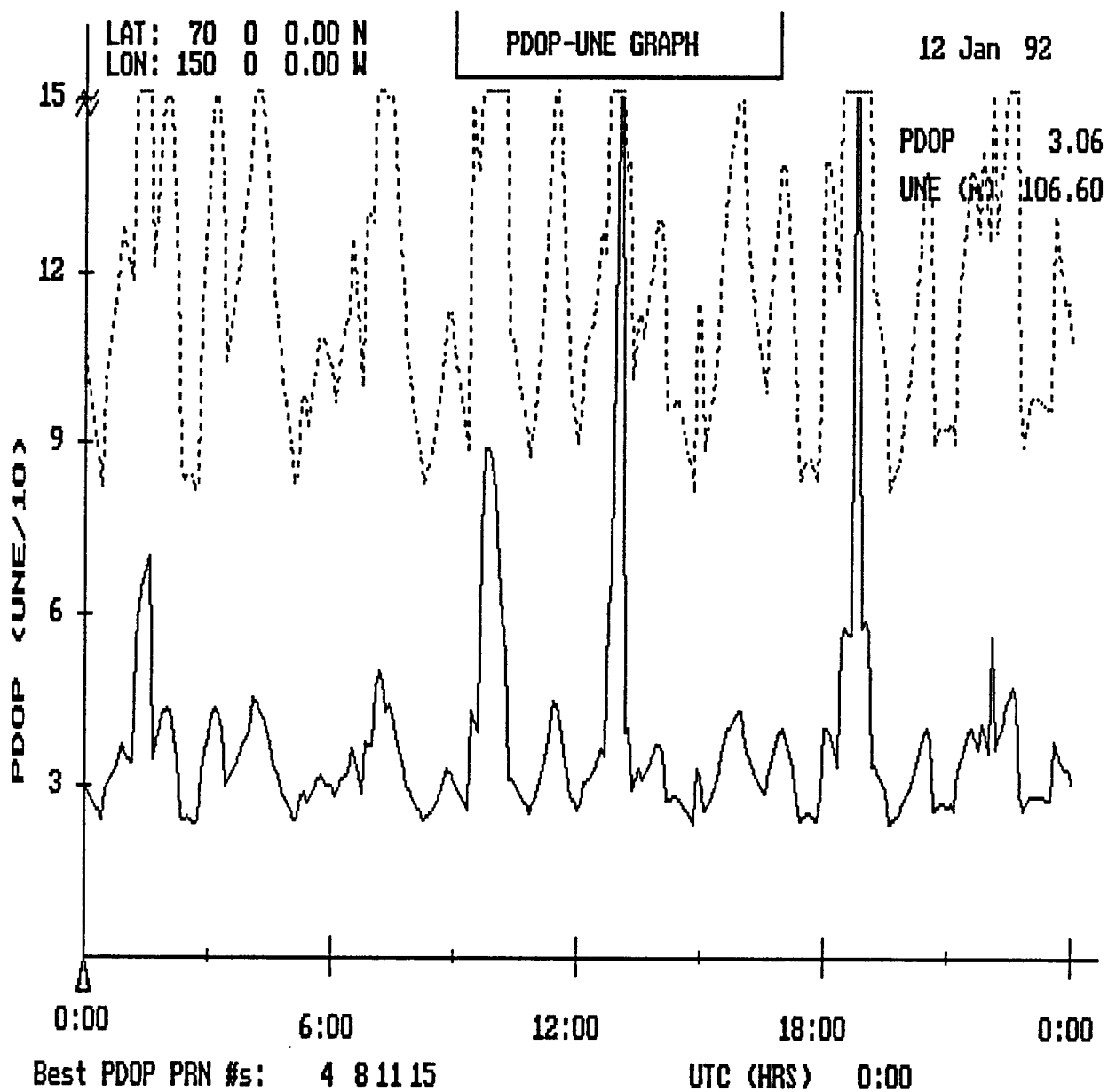

Figure A-12. GPS PDOP At High-Latitudes.
Mask Angle of 15 Degrees.

II. GLONASS-ONLY OPERATION FOR 24 HOURS

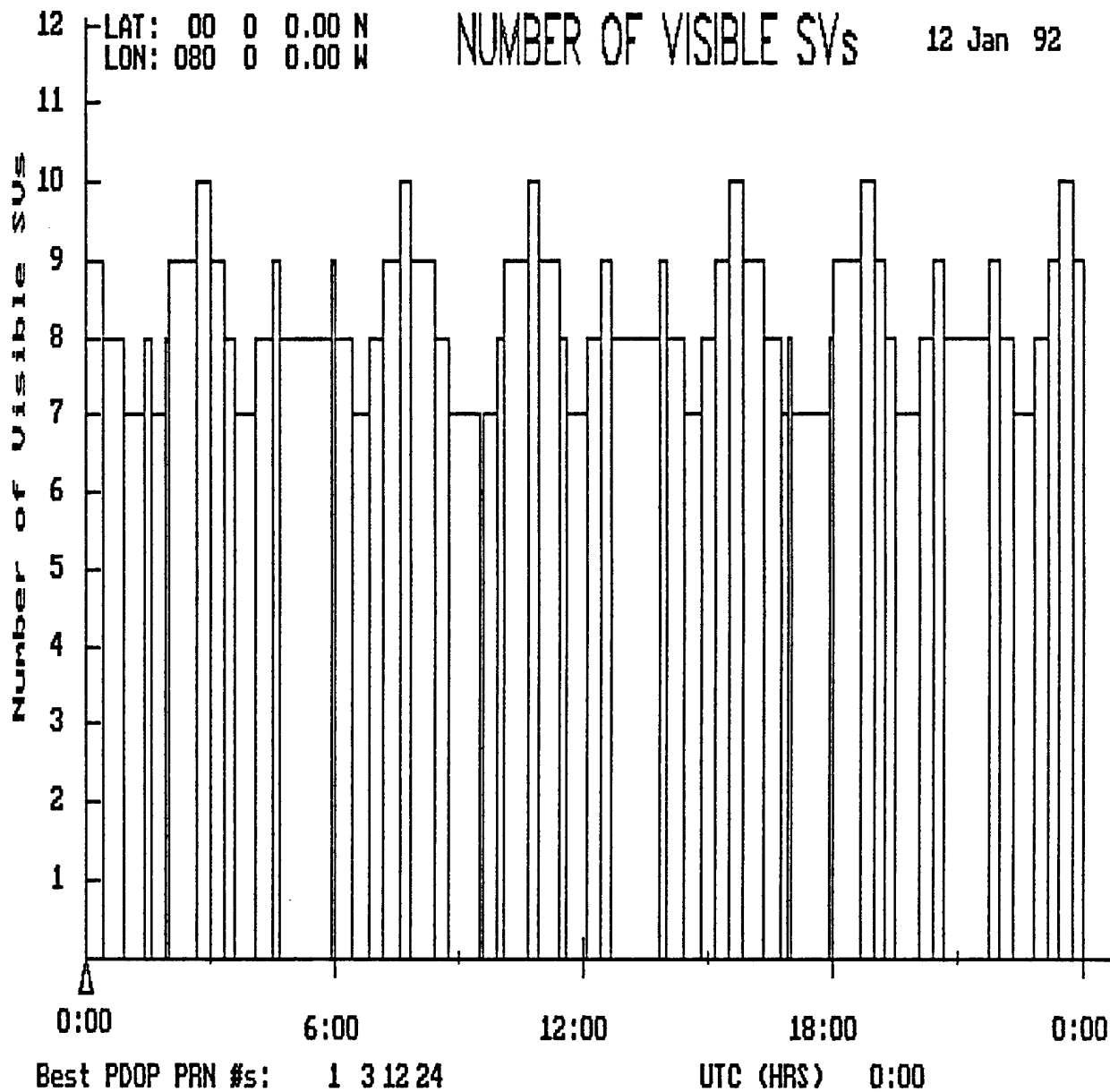

Figure A-13. Number of Visible GLONASS Satellites At Low-Latitudes. Mask Angle of 5 Degrees.

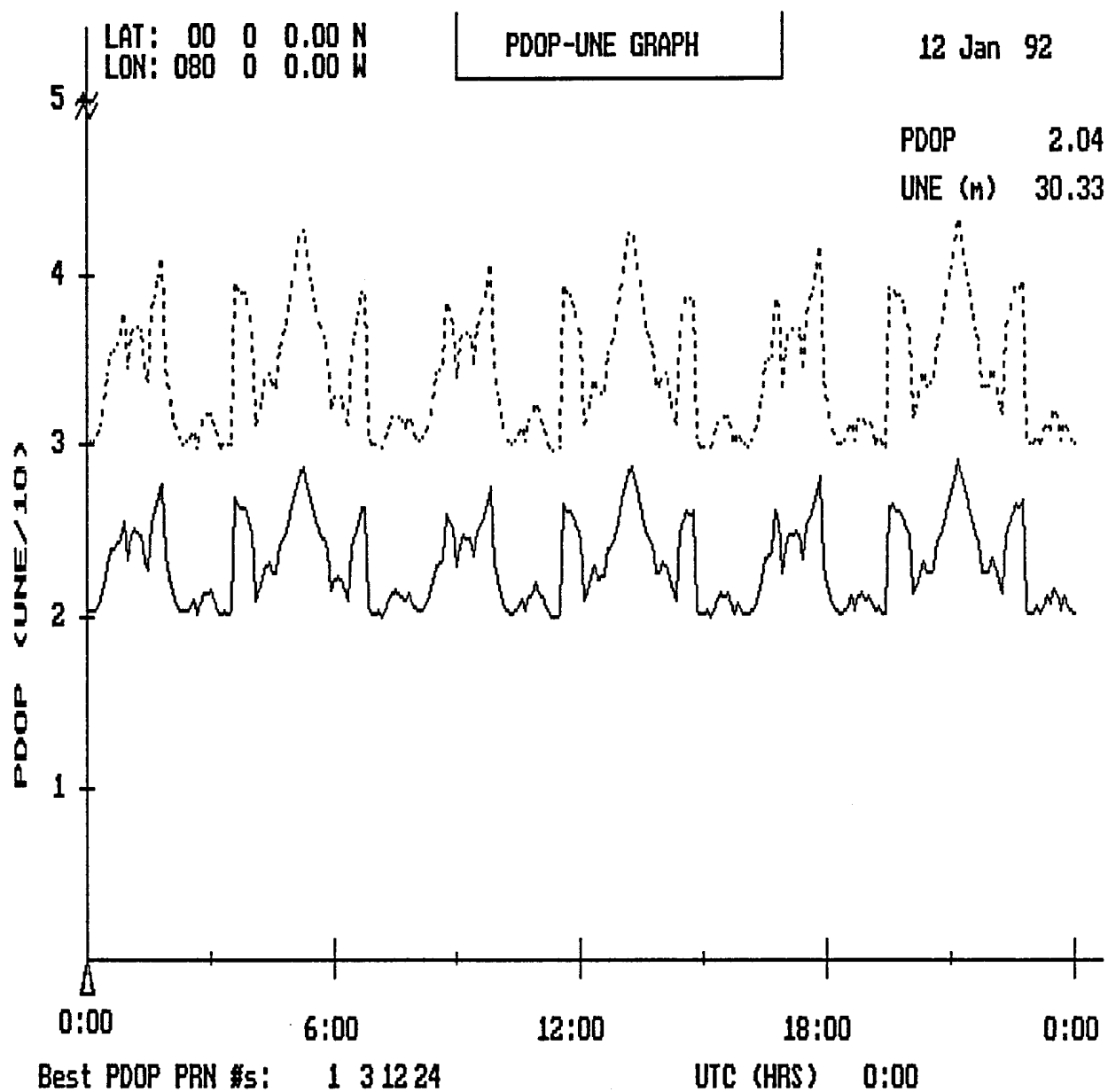

Figure A-14. GLONASS PDOP At Low-Latitudes.
 Mask Angle of 5 Degrees.

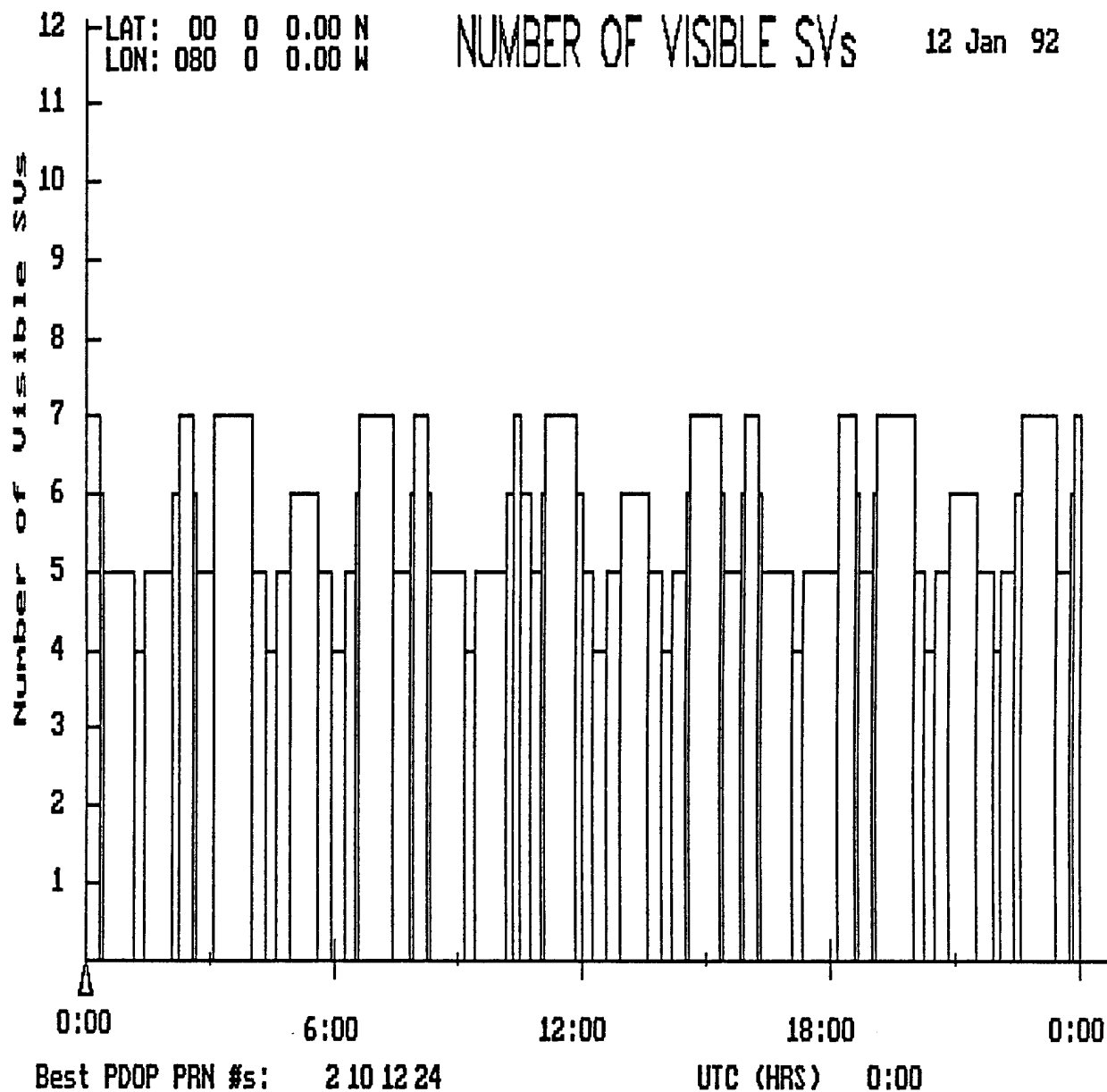

Figure A-15. Number of Visible GLONASS Satellites At Low-Latitudes. Mask Angle of 15 Degrees.

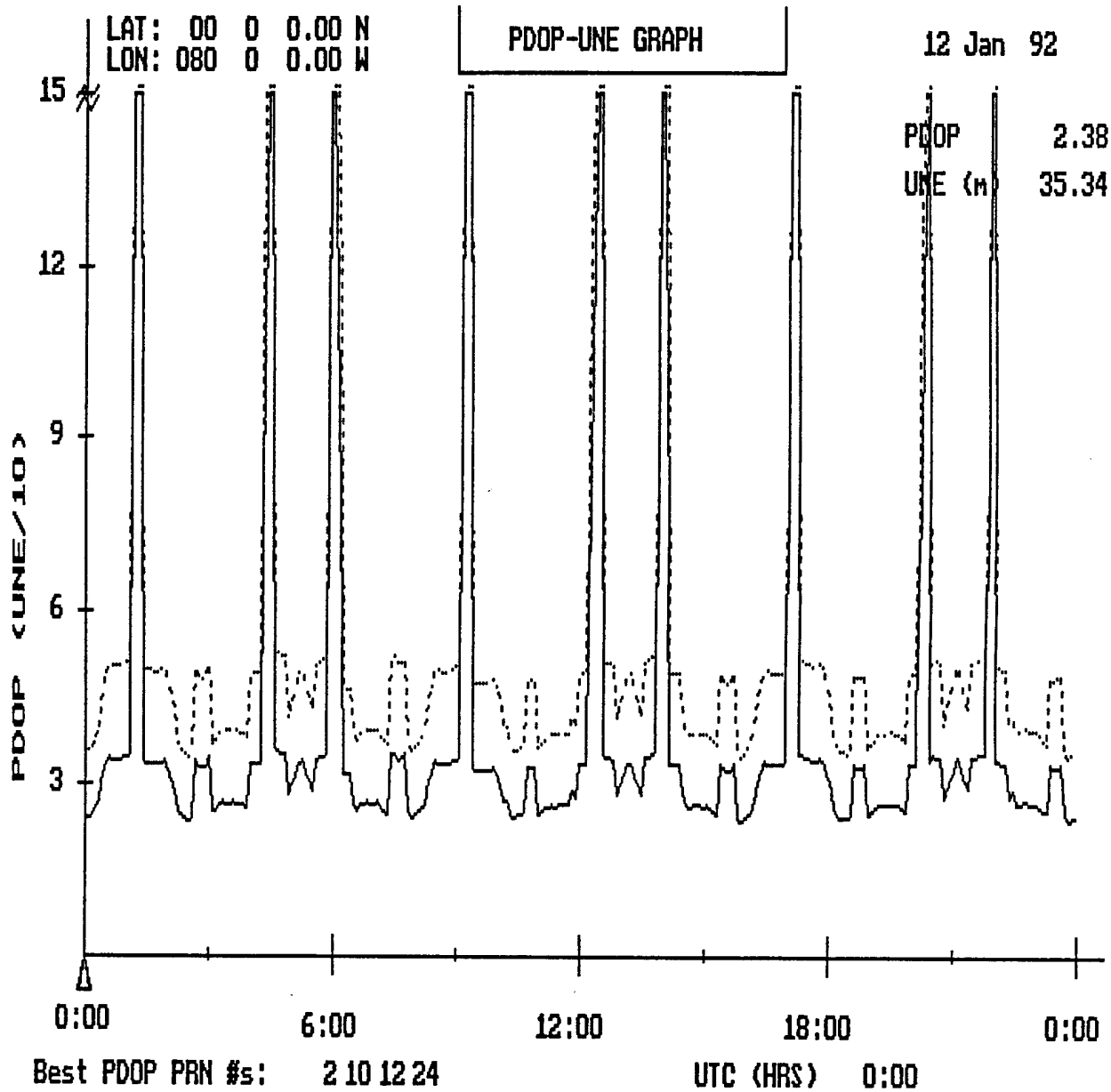

Figure A-16. GLONASS PDOP At Low-Latitudes.
Mask Angle of 15 Degrees.

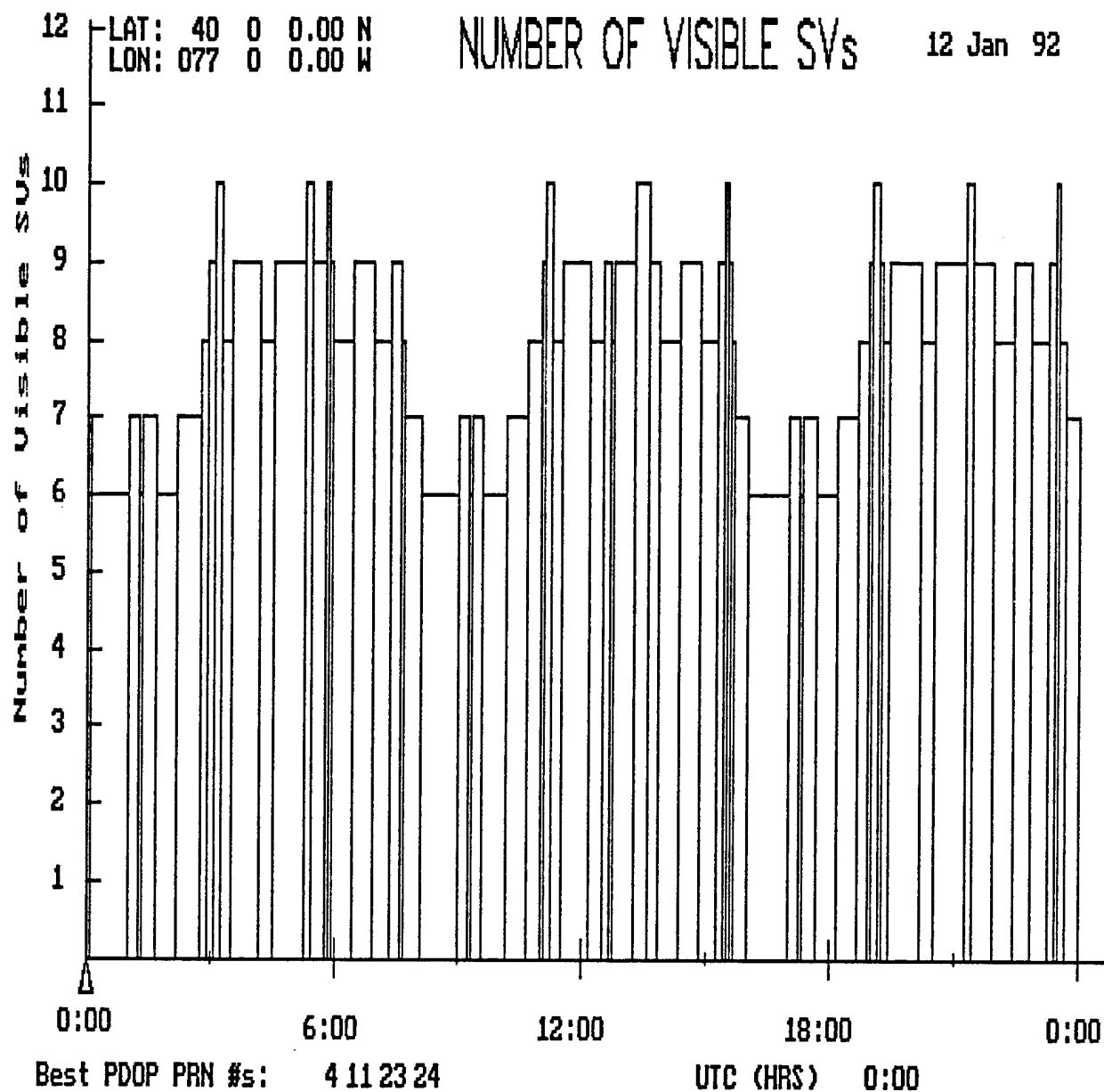

Figure A-17. Number of Visible GLONASS Satellites At Mid-Latitudes. Mask Angle of 5 Degrees.

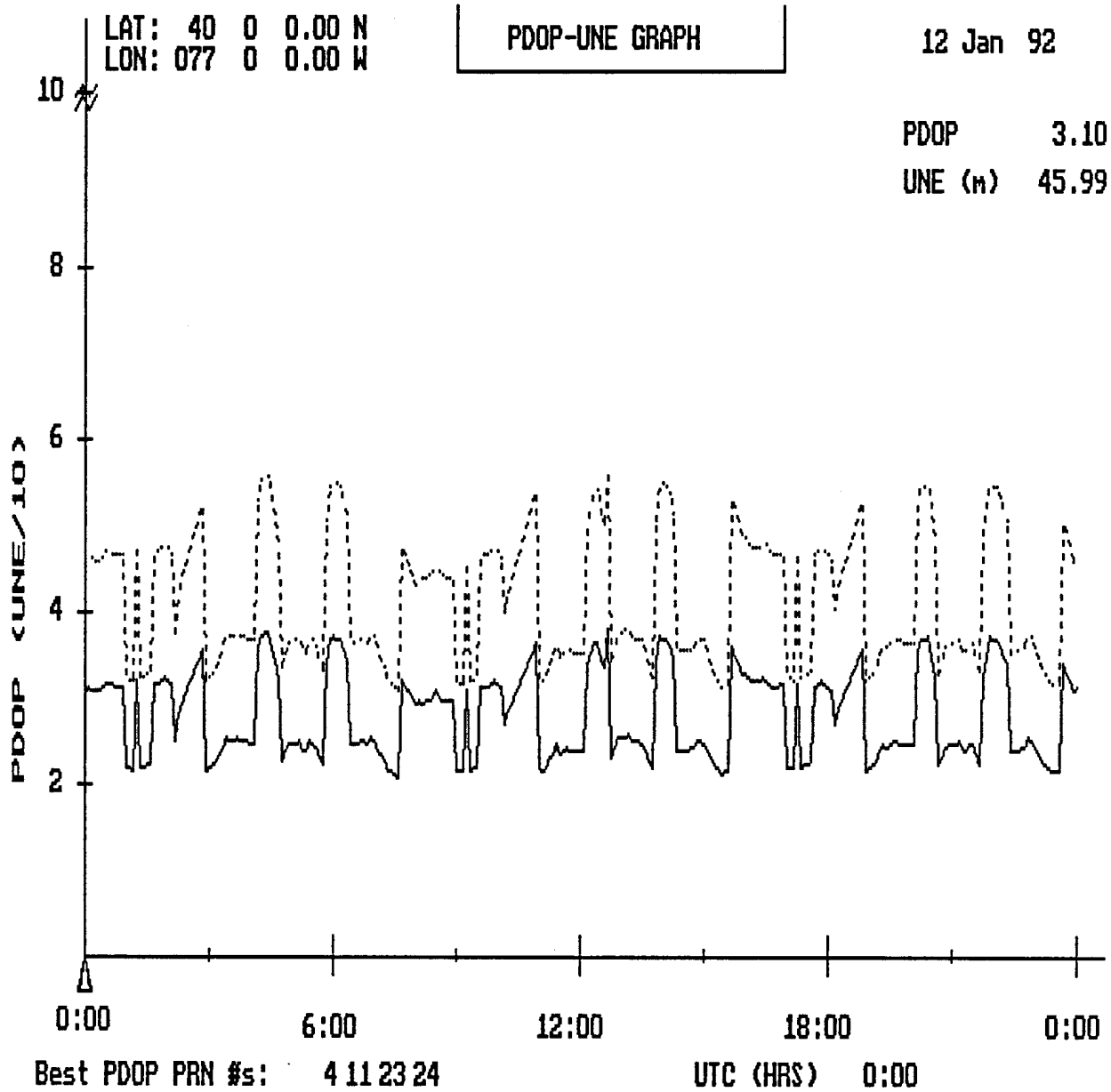

Figure A-18. GLONASS PDOP At Mid-Latitudes.
 Mask Angle of 5 Degrees.

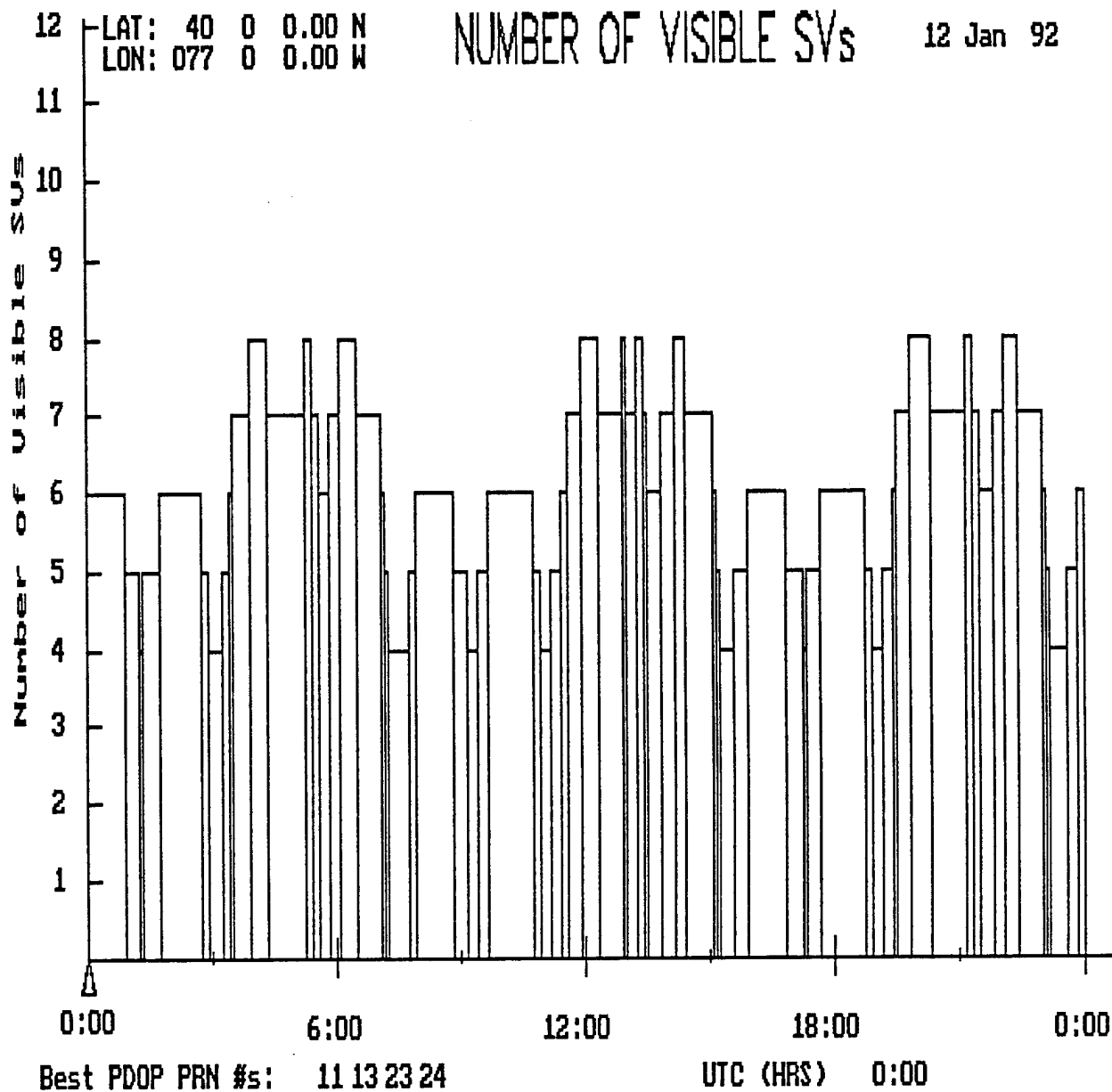

Figure A-19. Number of Visible GLONASS Satellites At Mid-Latitudes. Mask Angle of 15 Degrees.

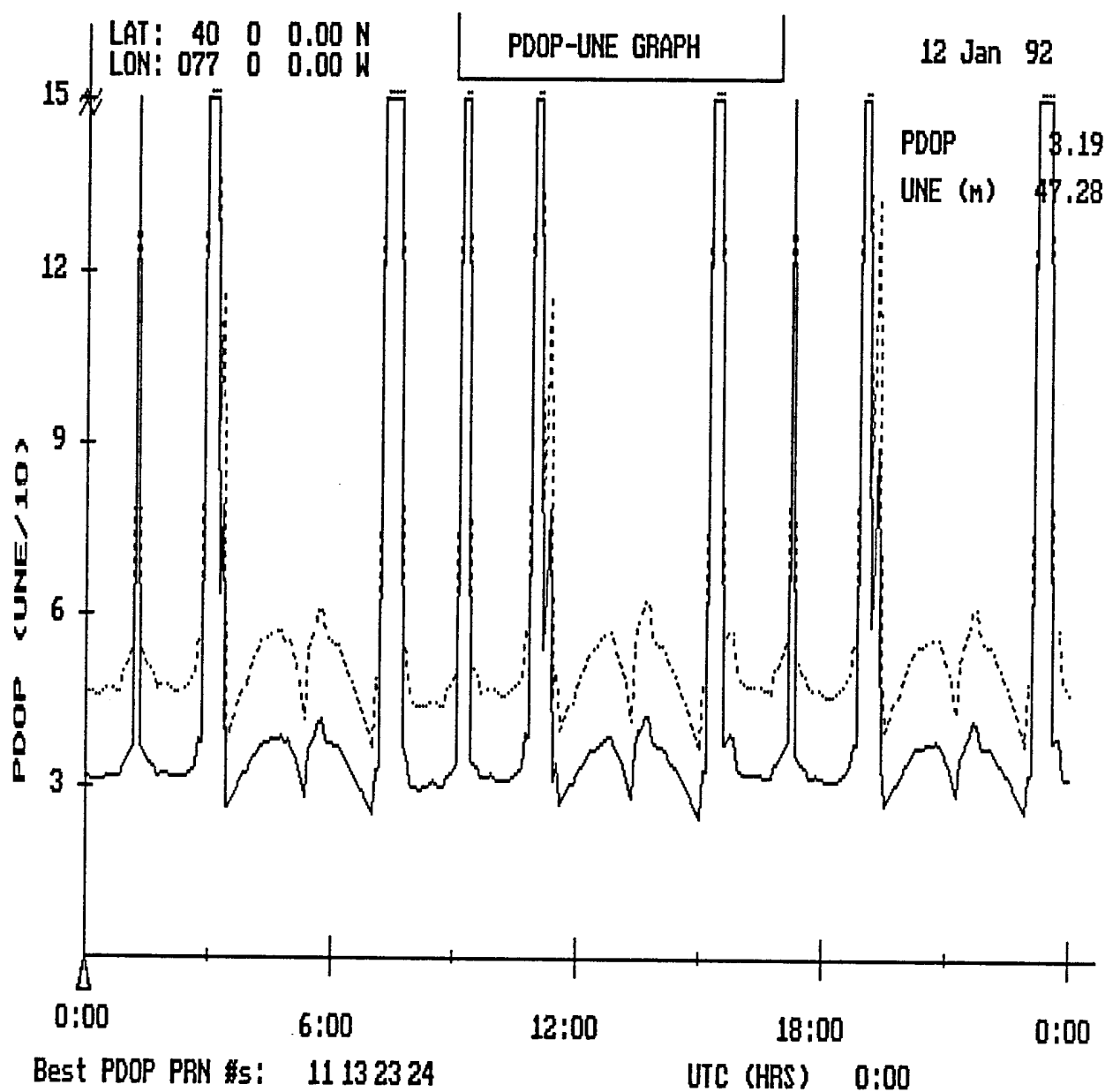

Figure A-20. GLONASS PDOP At Mid-Latitudes.
Mask Angle of 15 Degrees.

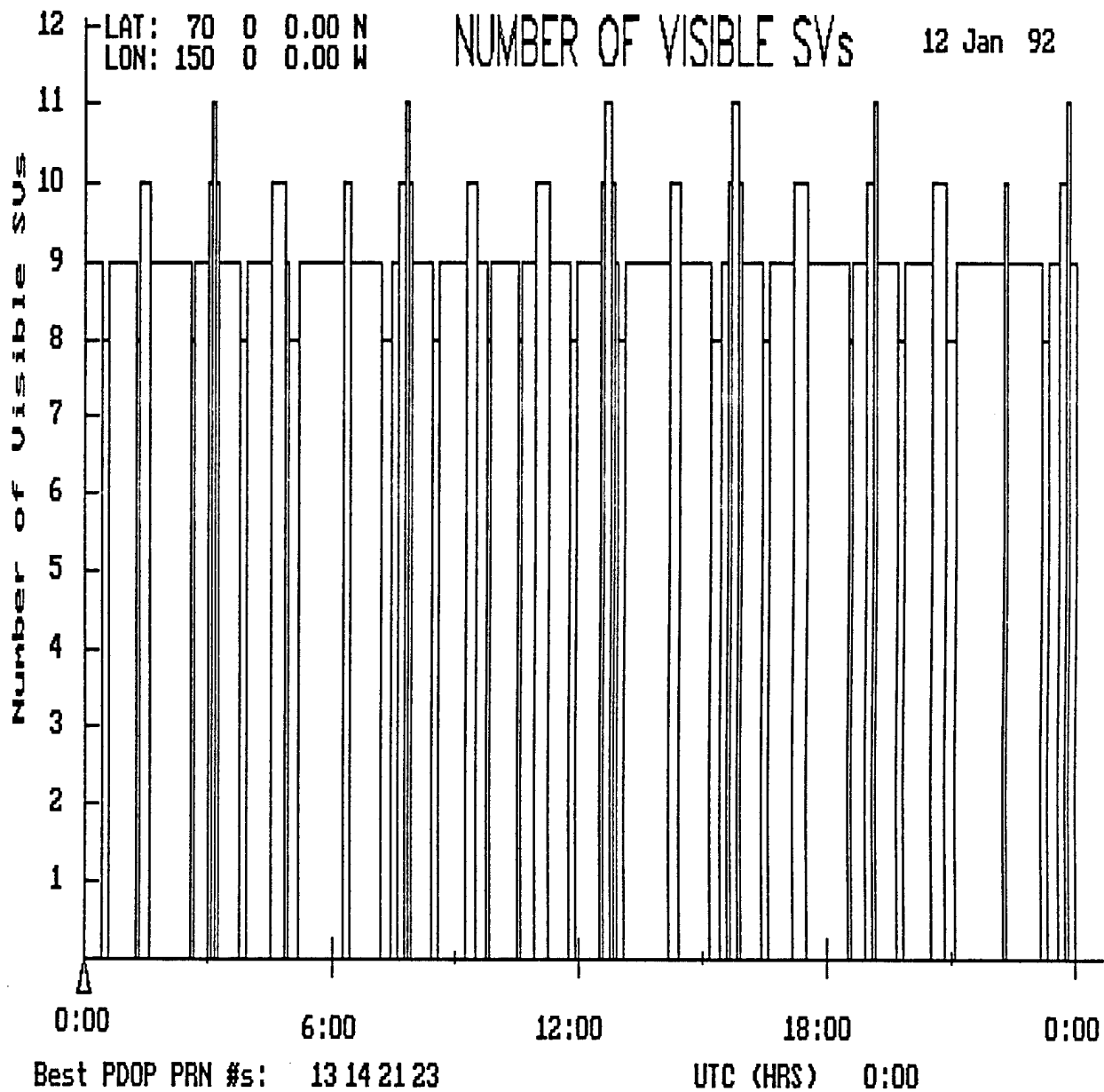

Figure A-21. Number of Visible GLONASS Satellites At High-Latitudes. Mask Angle of 5 Degrees.

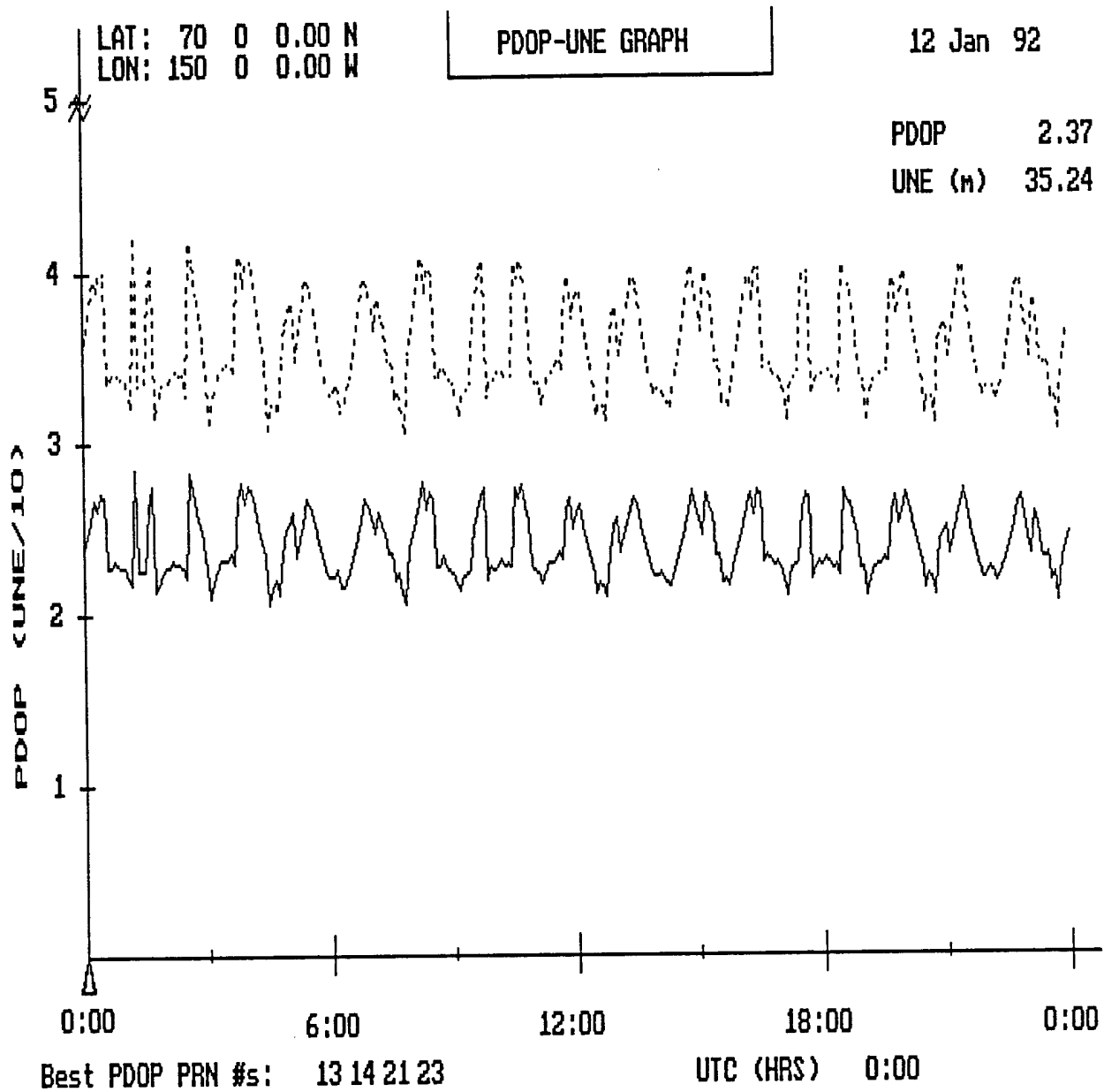

Figure A-22. GLONASS PDOP At High-Latitudes.
Mask Angle of 5 Degrees.

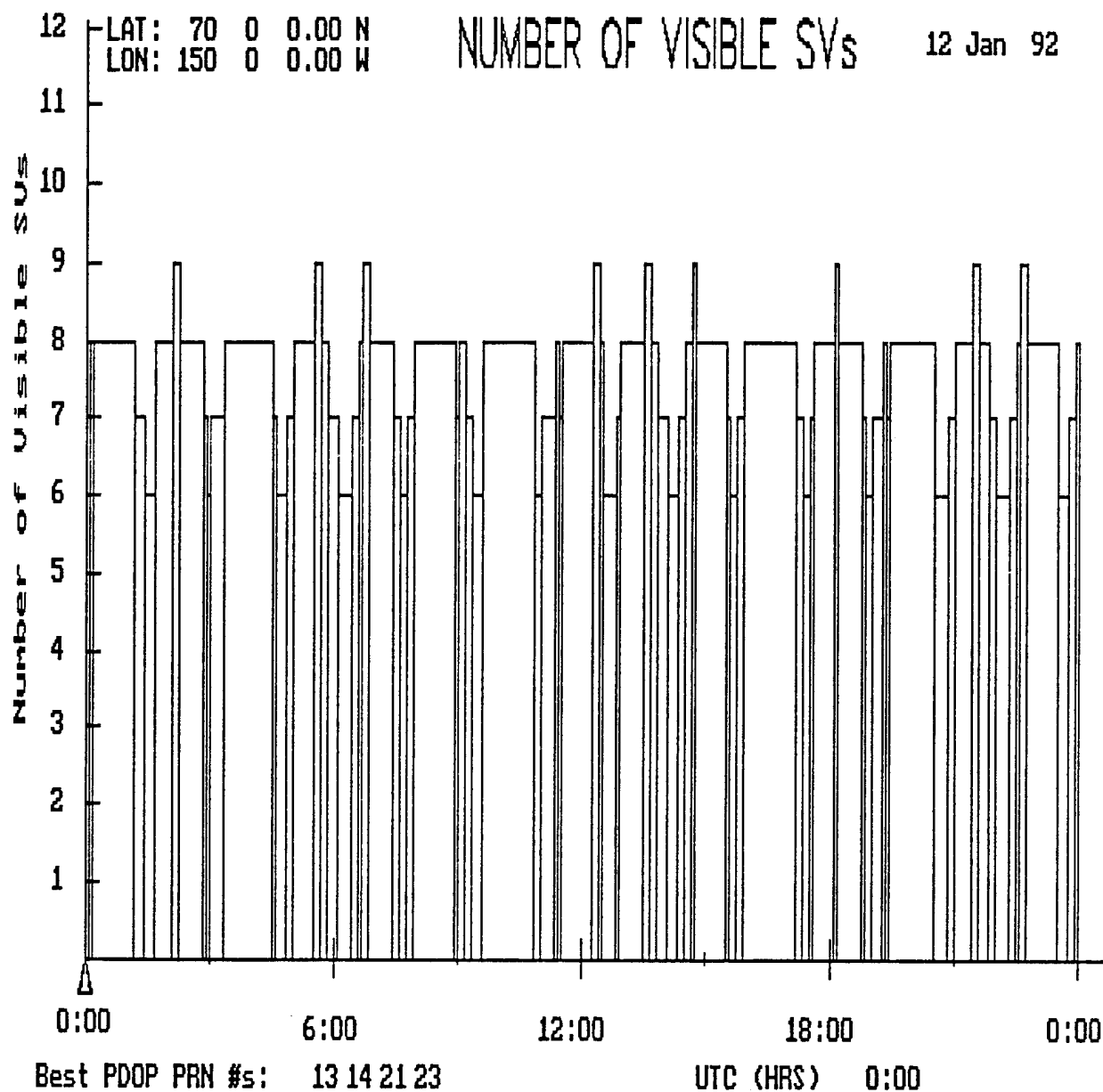

Figure A-23. Number of Visible GLONASS Satellites At High-Latitudes. Mask Angle of 15 Degrees.

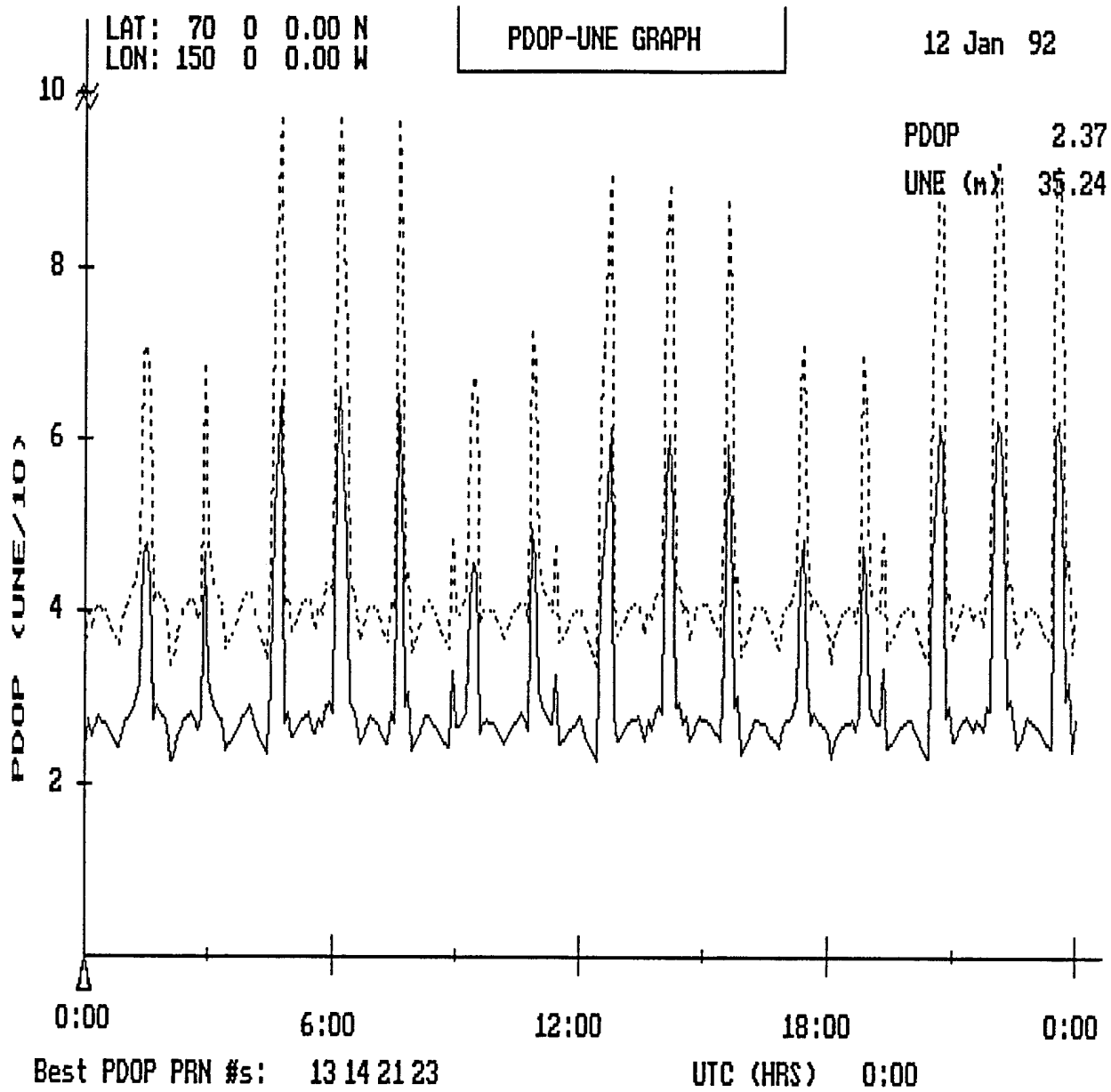

Figure A-24. GLONASS PDOP At High-Latitudes.
Mask Angle of 15 Degrees.

III. GPS-ONLY OPERATION FOR 3 HOURS

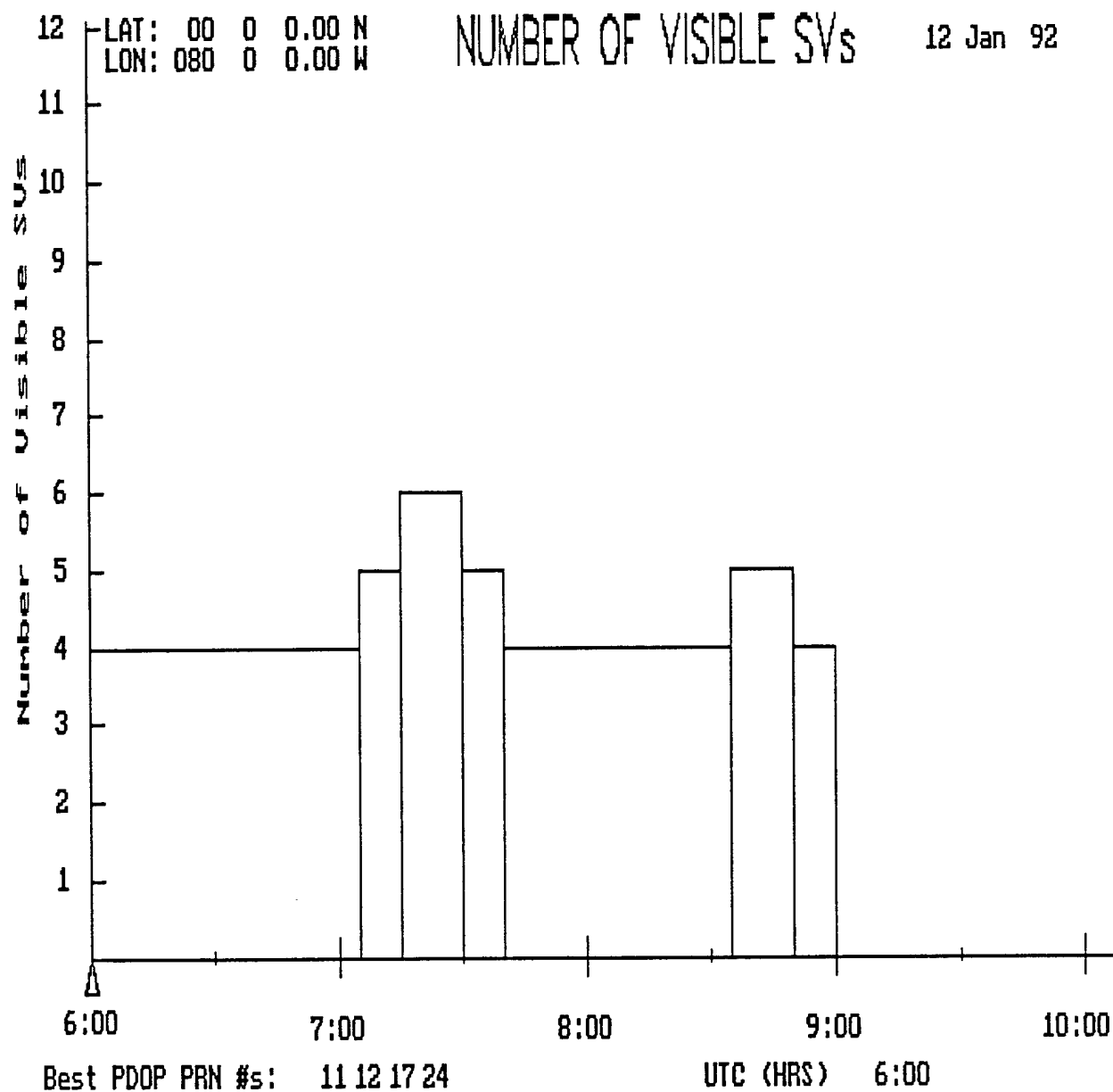

Figure A-25. Number of Visible GPS Satellites At Low-Latitudes. Mask Angle of 30 Degrees.

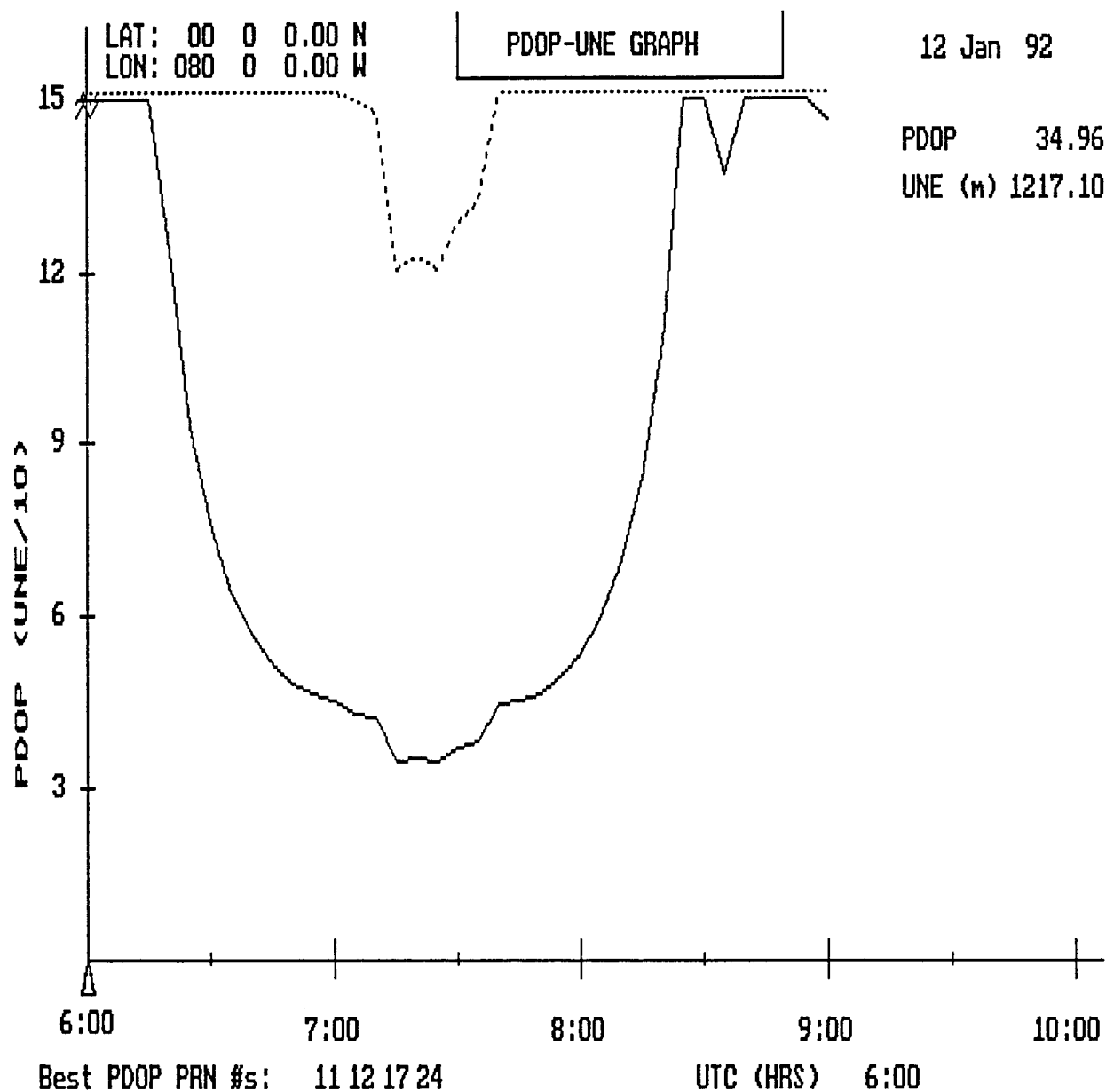

Figure A-26. GPS PDOP At Low-Latitudes.
Mask Angle of 30 Degrees.

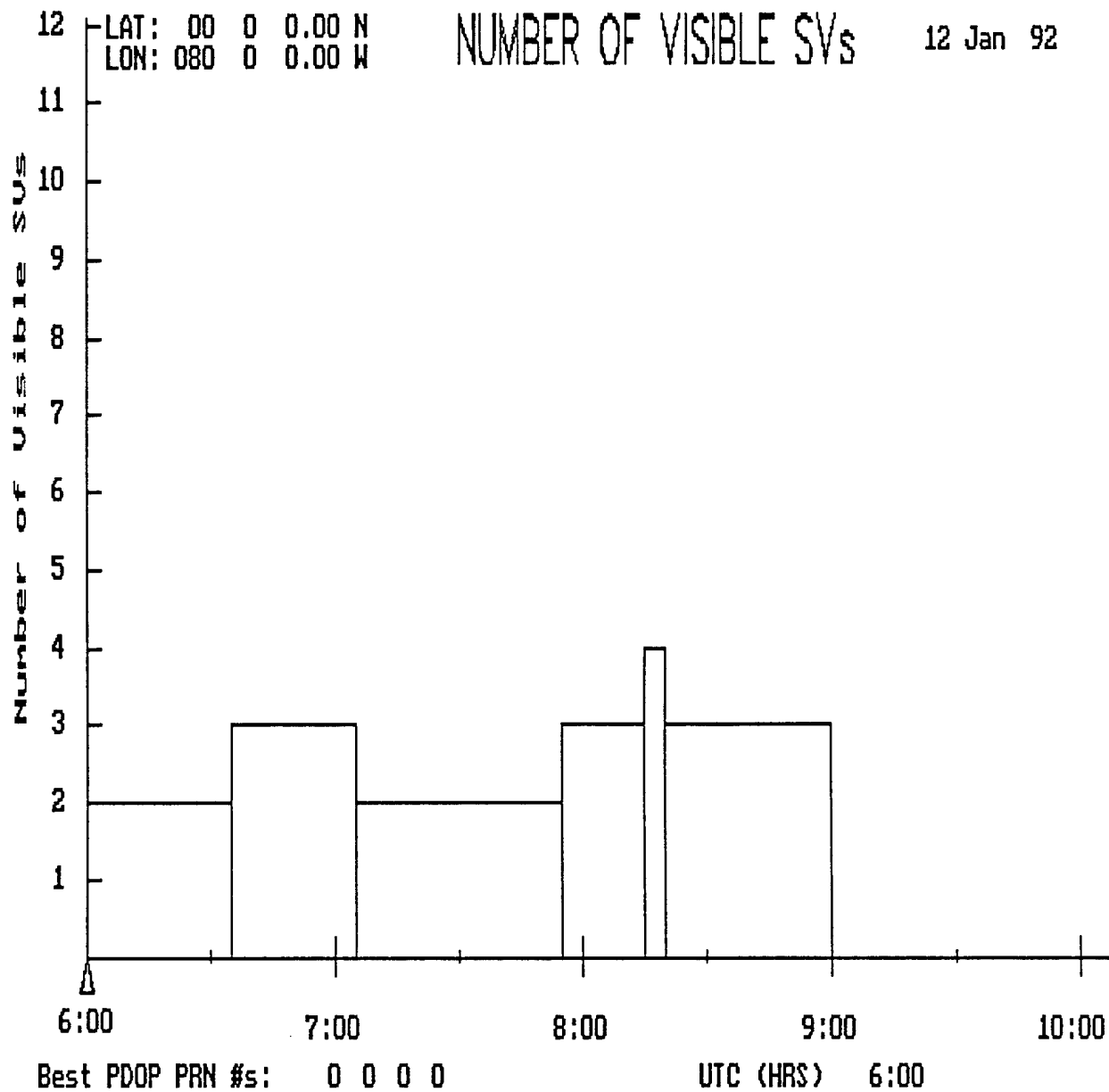

Figure A-27. Number of Visible GPS Satellites At Low-Latitudes. Mask Angle of 45 Degrees.

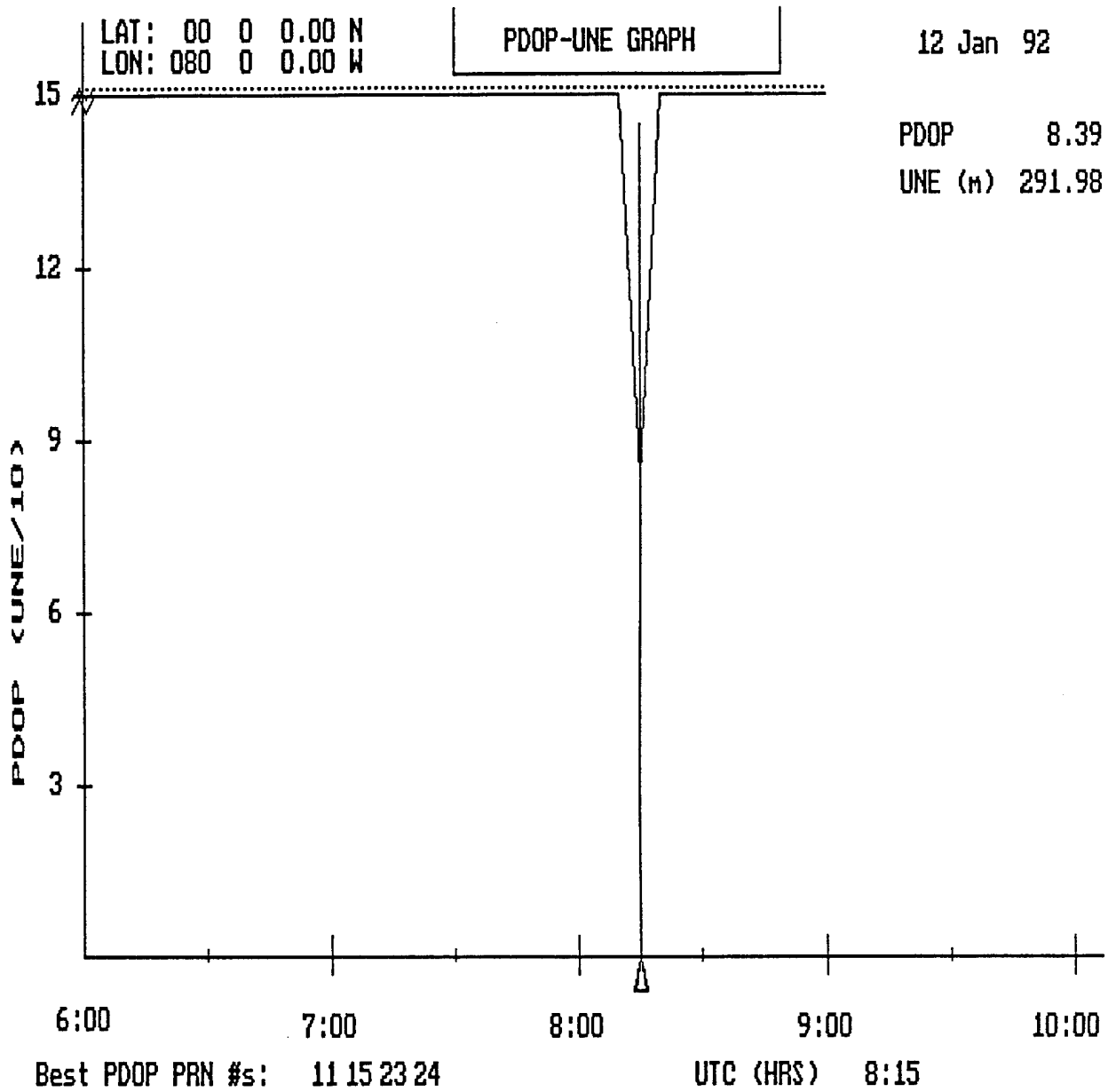

Figure A-28. GPS PDOP At Low-Latitudes.
Mask Angle of 45 Degrees.

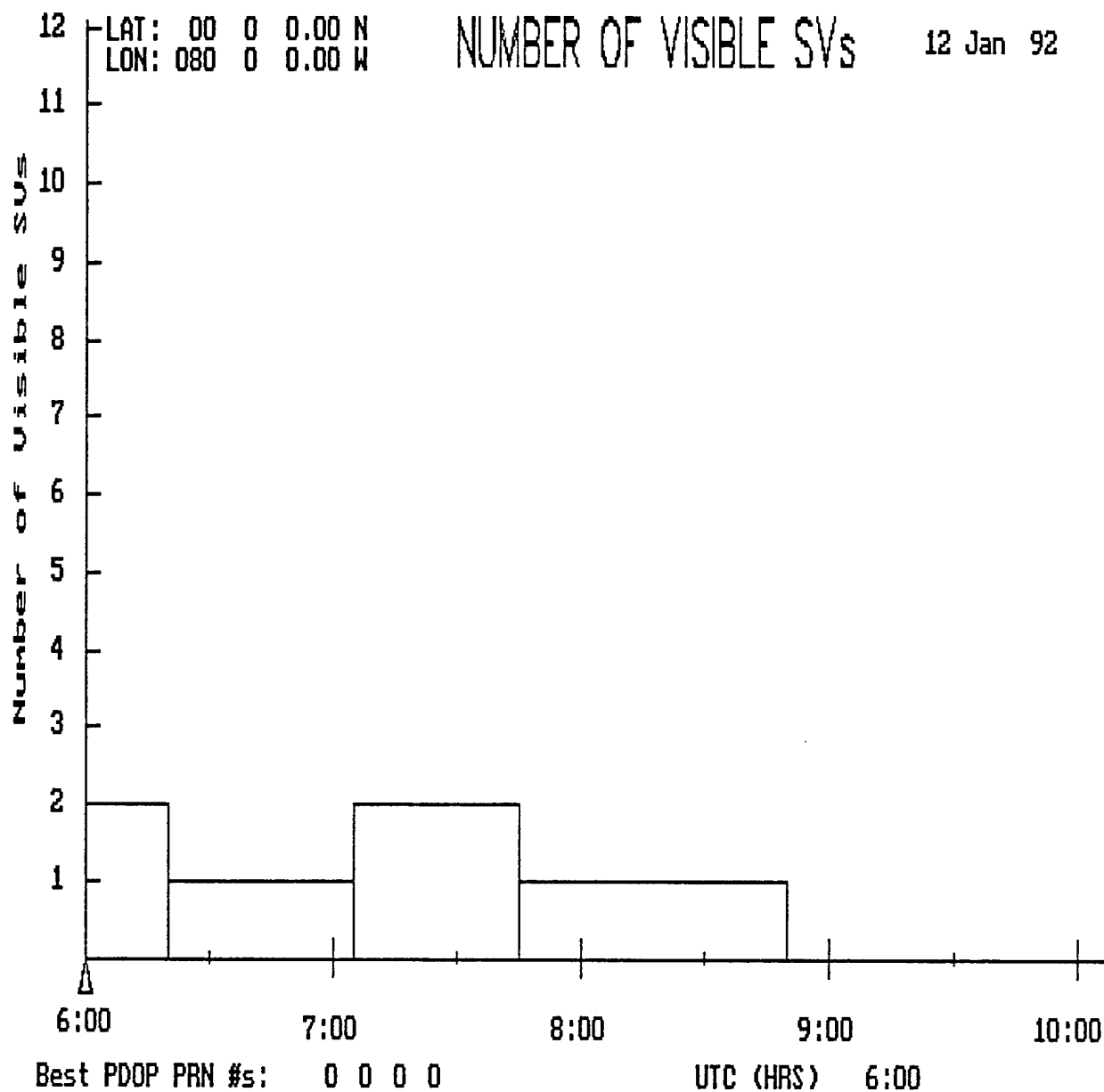

Figure A-29. Number of Visible GPS Satellites At Low-Latitudes. Mask Angle of 60 Degrees.

NO SOLUTION FOR PDOP SINCE NOT ENOUGH SATELLITES ARE VISIBLE

Figure A-30. GPS PDOP At Low-Latitudes.
Mask Angle of 60 Degrees.

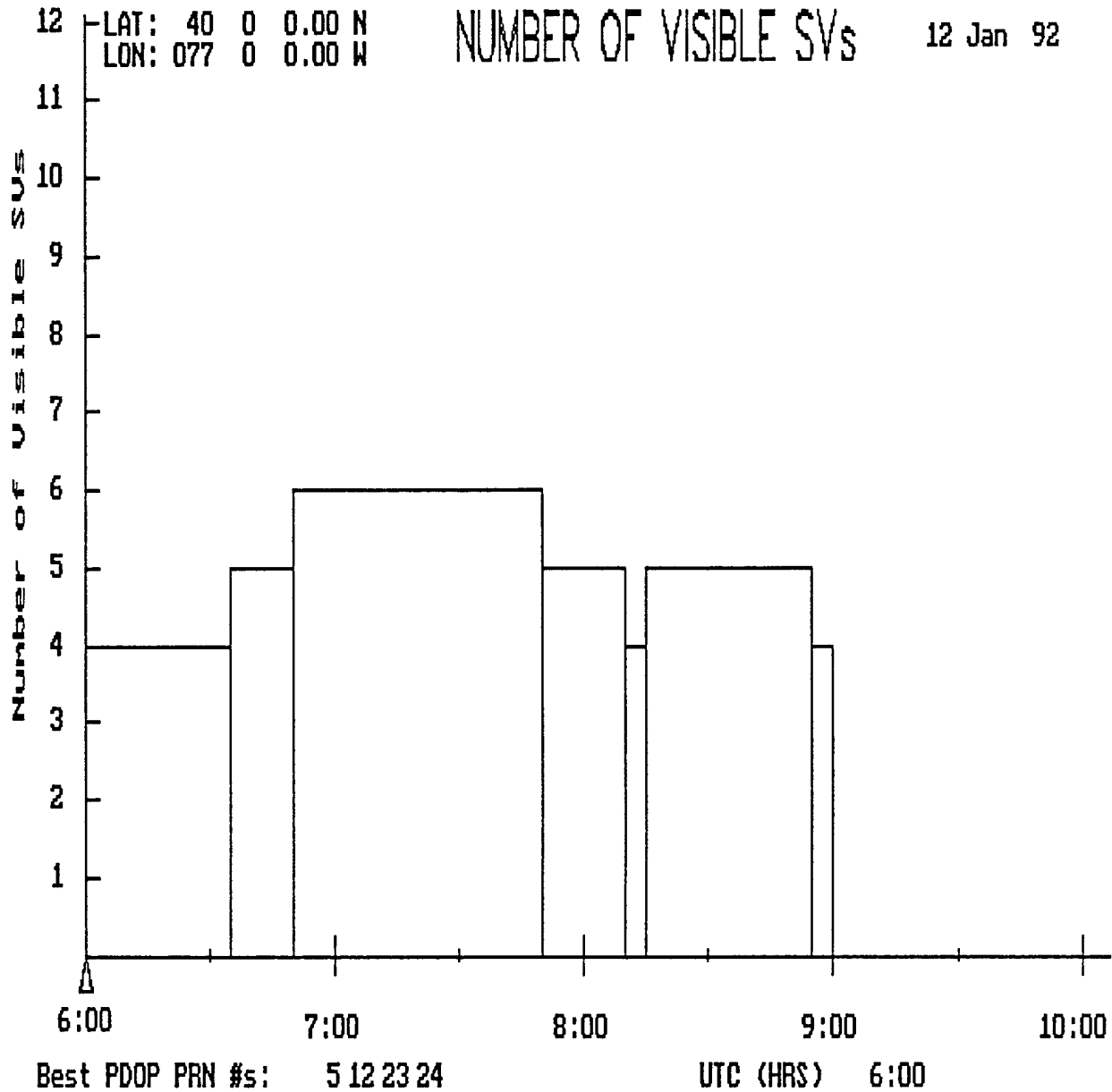

Figure A-31. Number of Visible GPS Satellites At Mid-Latitudes. Mask Angle of 30 Degrees.

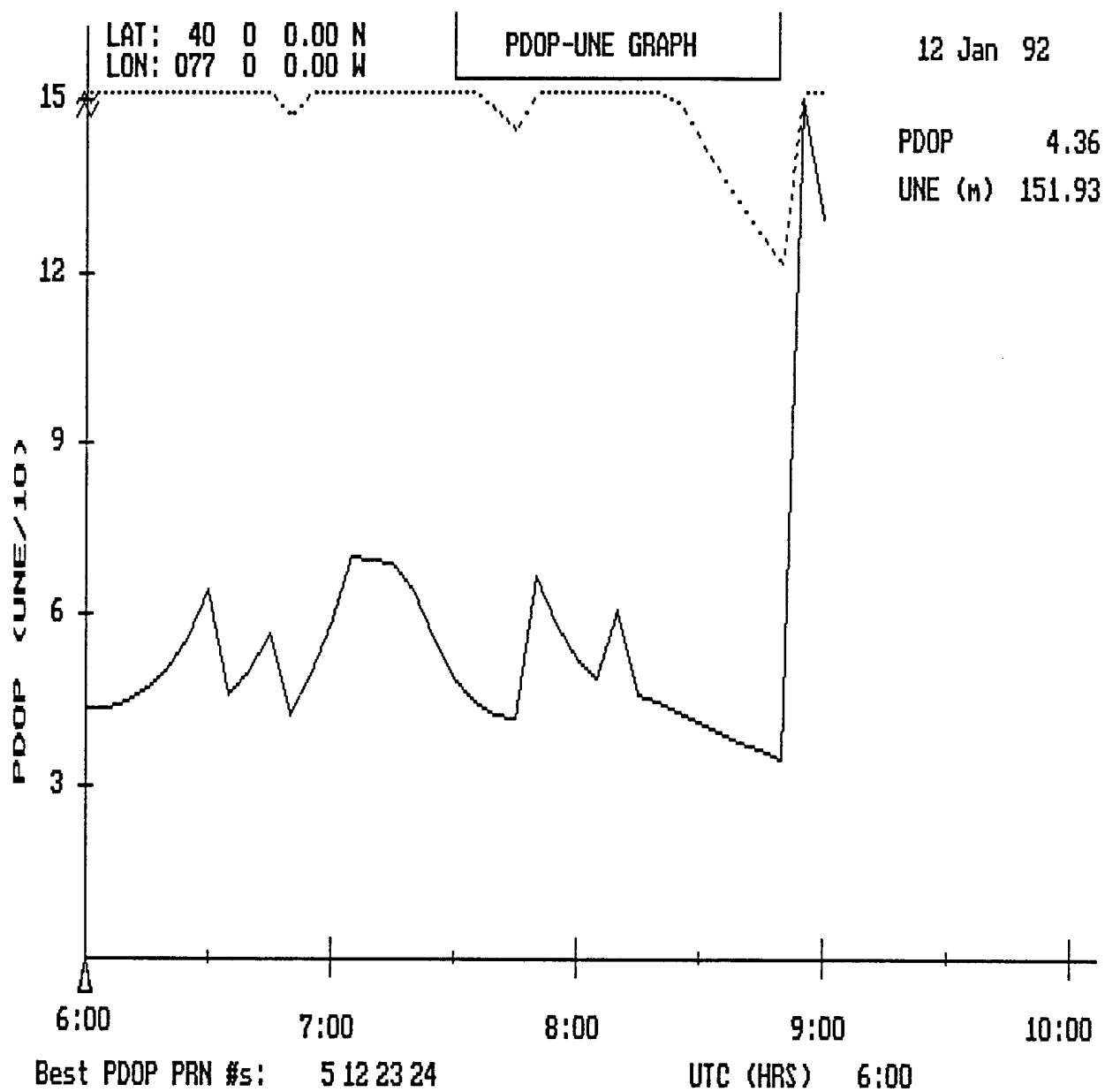

Figure A-32. GPS PDOP At Mid-Latitudes.
Mask Angle of 30 Degrees.

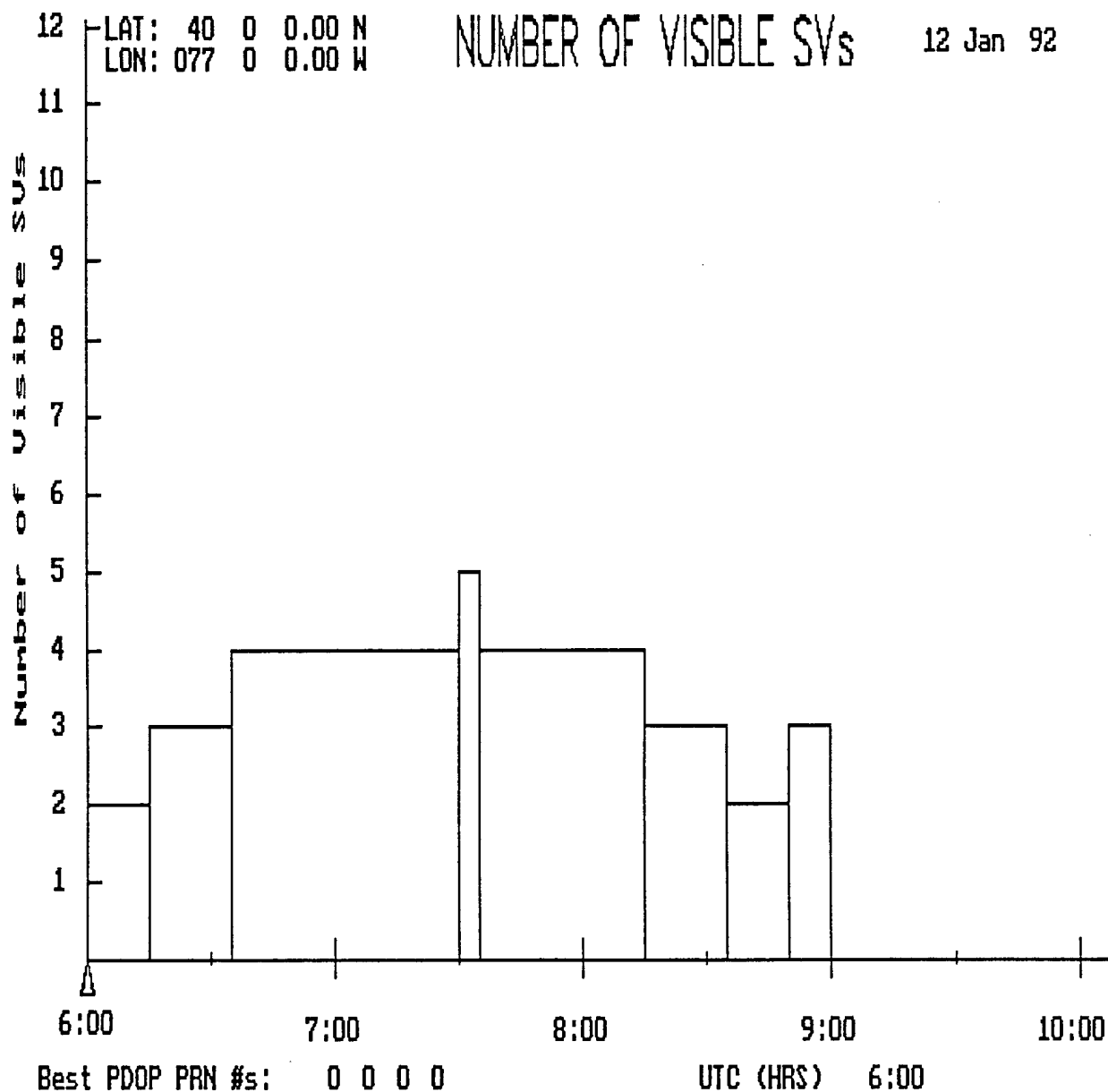

Figure A-33. Number of Visible GPS Satellites At Mid-Latitudes. Mask Angle of 45 Degrees.

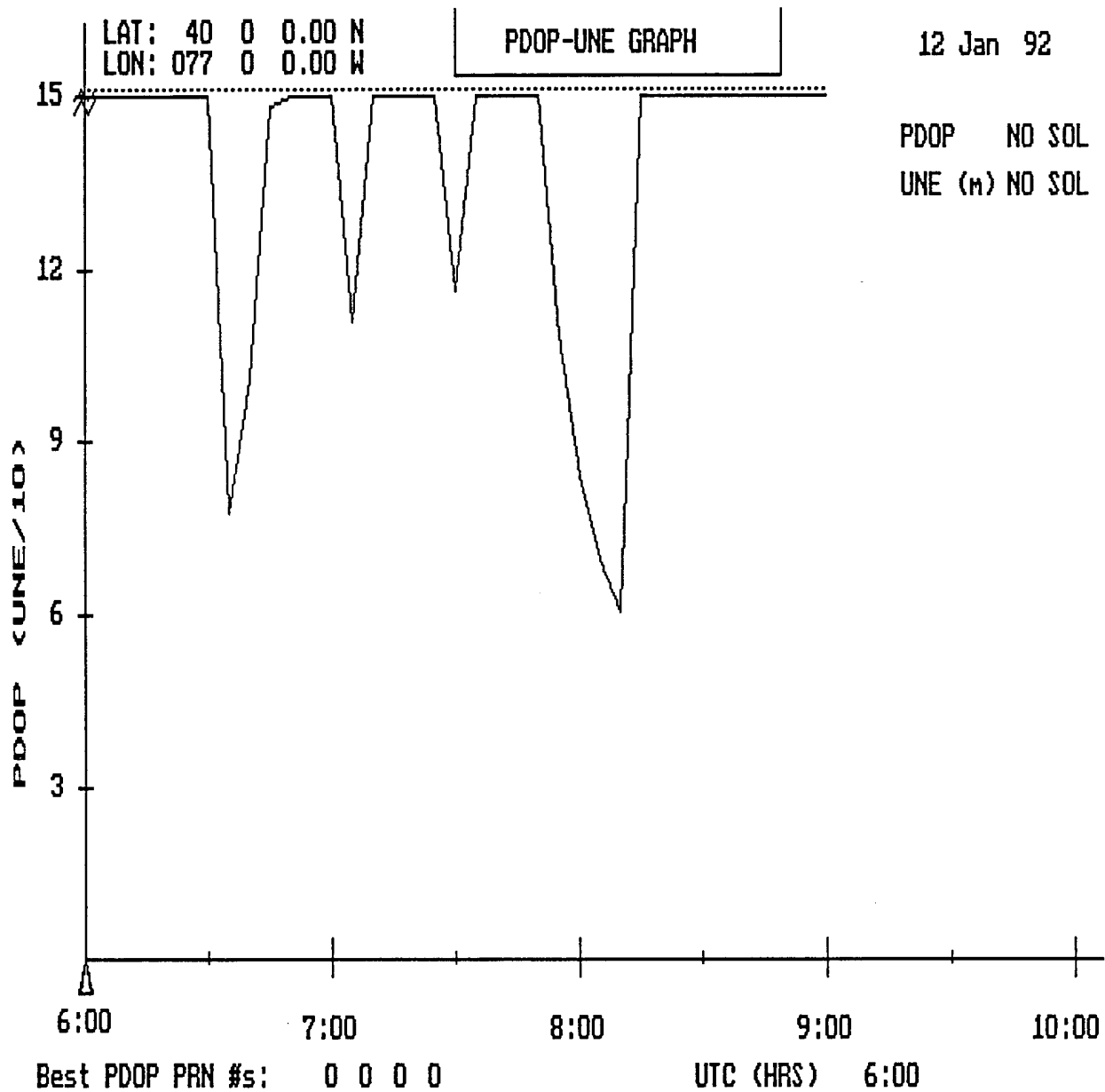

Figure A-34. GPS PDOP At Mid-Latitudes.
 Mask Angle of 45 Degrees.

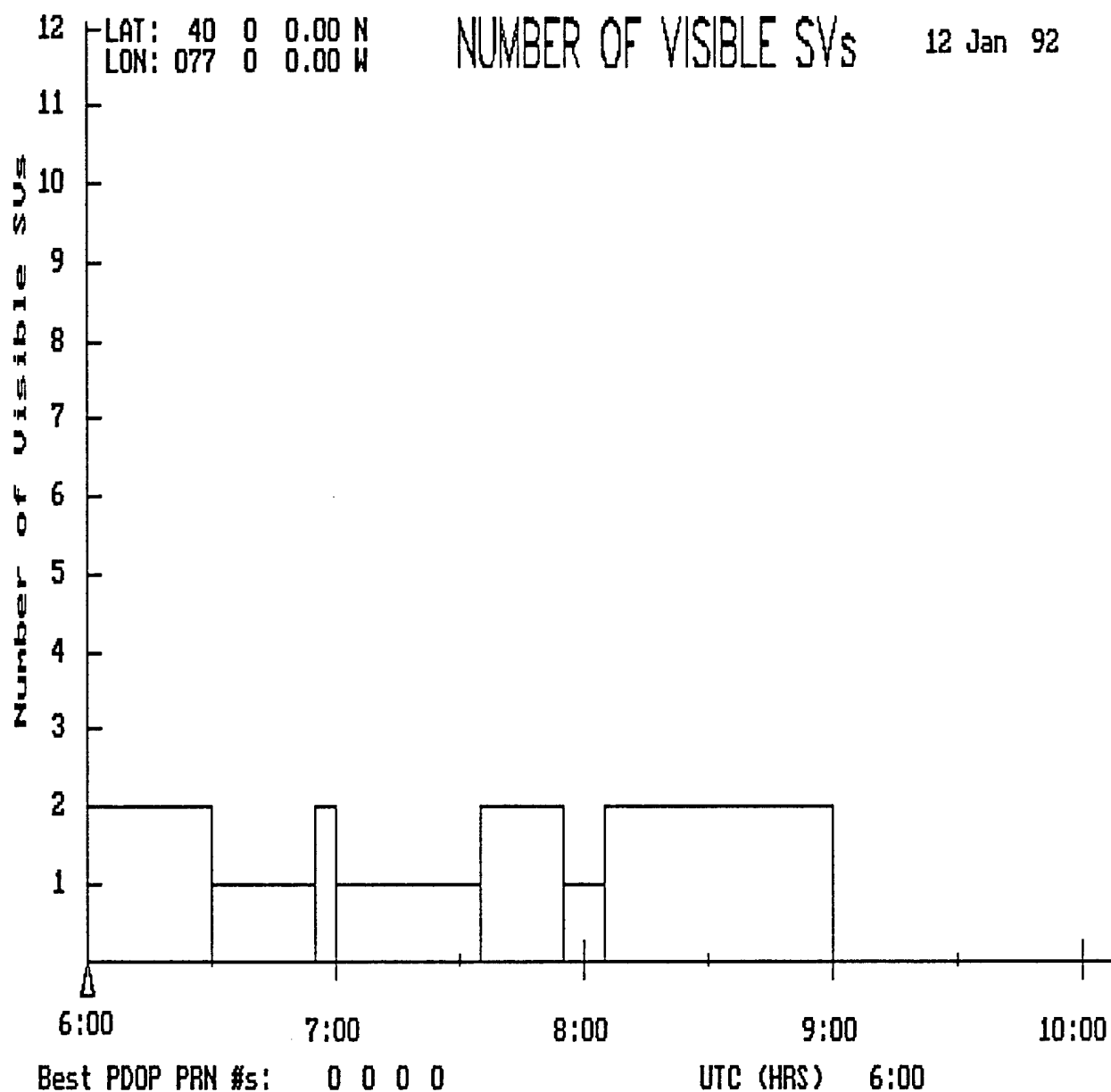

Figure A-35. Number of Visible GPS Satellites At Mid-Latitudes. Mask Angle of 60 Degrees.

NO SOLUTION FOR PDOP SINCE NOT ENOUGH SATELLITES ARE VISIBLE

Figure A-36. GPS PDOP At Mid-Latitudes.
Mask Angle of 60 Degrees.

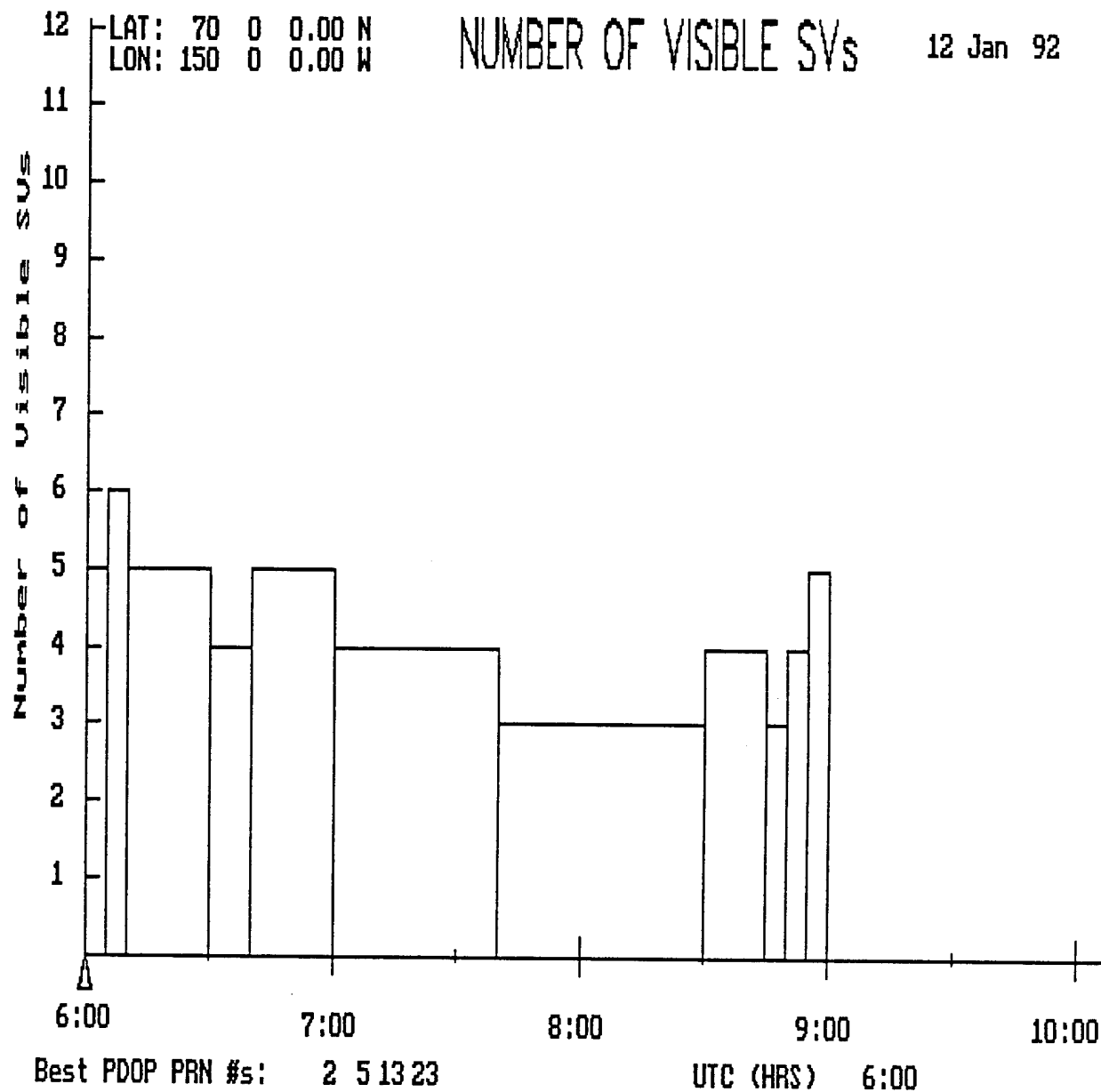

Figure A-37. Number of Visible GPS Satellites At High-Latitudes. Mask Angle of 30 Degrees.

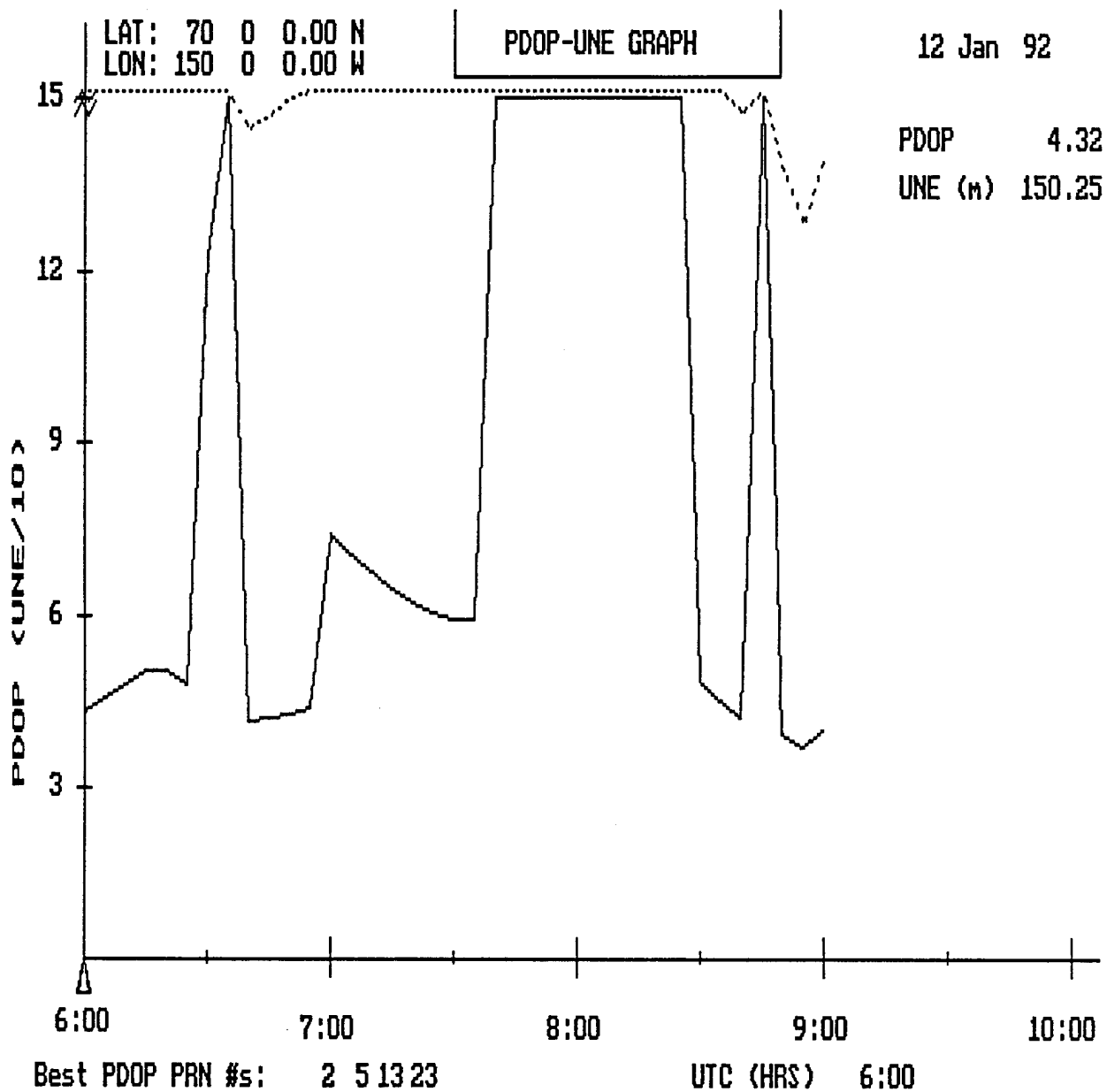

Figure A-38. GPS PDOP At High-Latitudes.
Mask Angle of 30 Degrees.

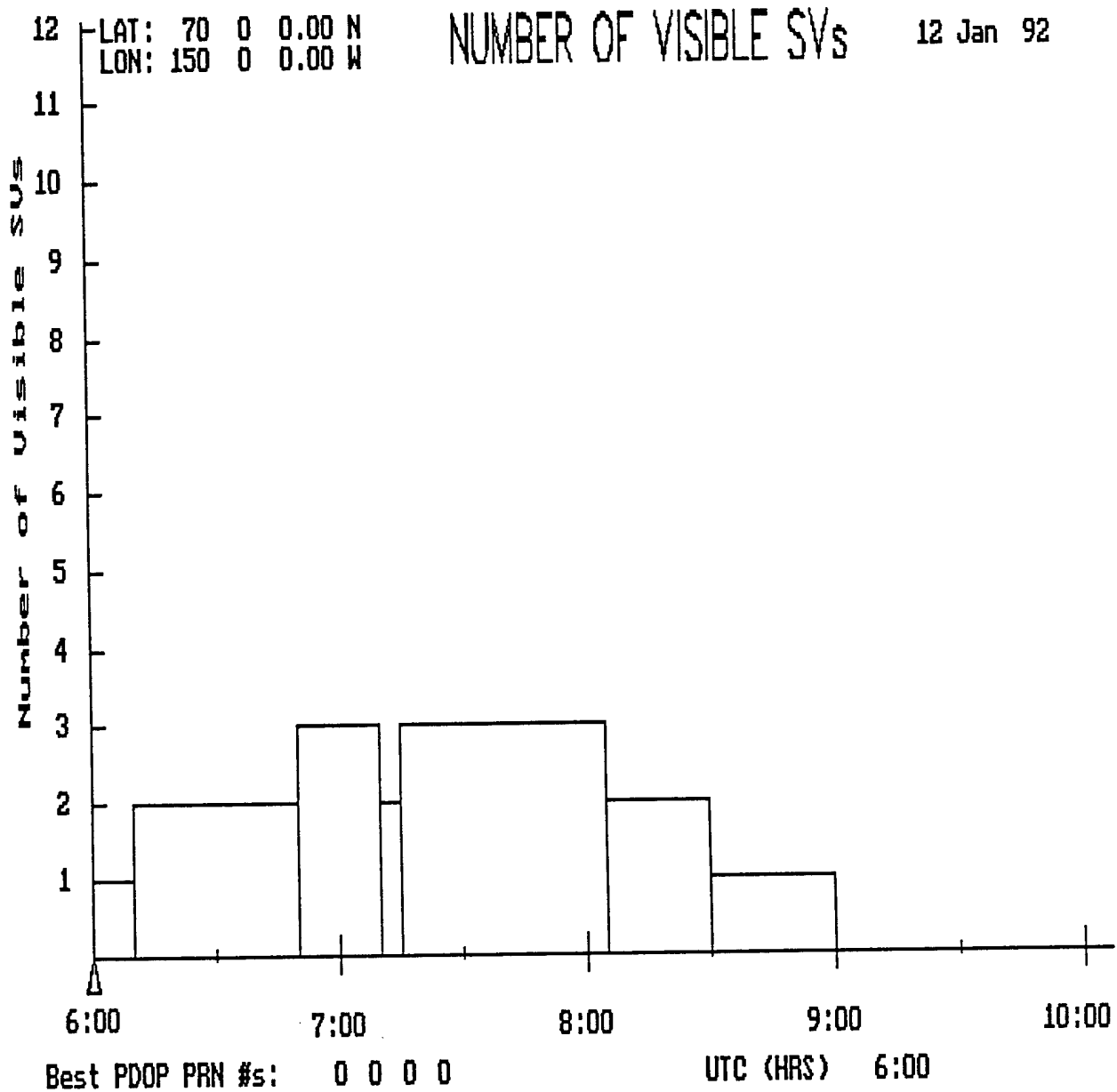

Figure A-39. Number of Visible GPS Satellites At High-Latitudes. Mask Angle of 45 Degrees.

NO SOLUTION FOR PDOP SINCE NOT ENOUGH SATELLITES ARE VISIBLE

Figure A-40. GPS PDOP At High-Latitudes.

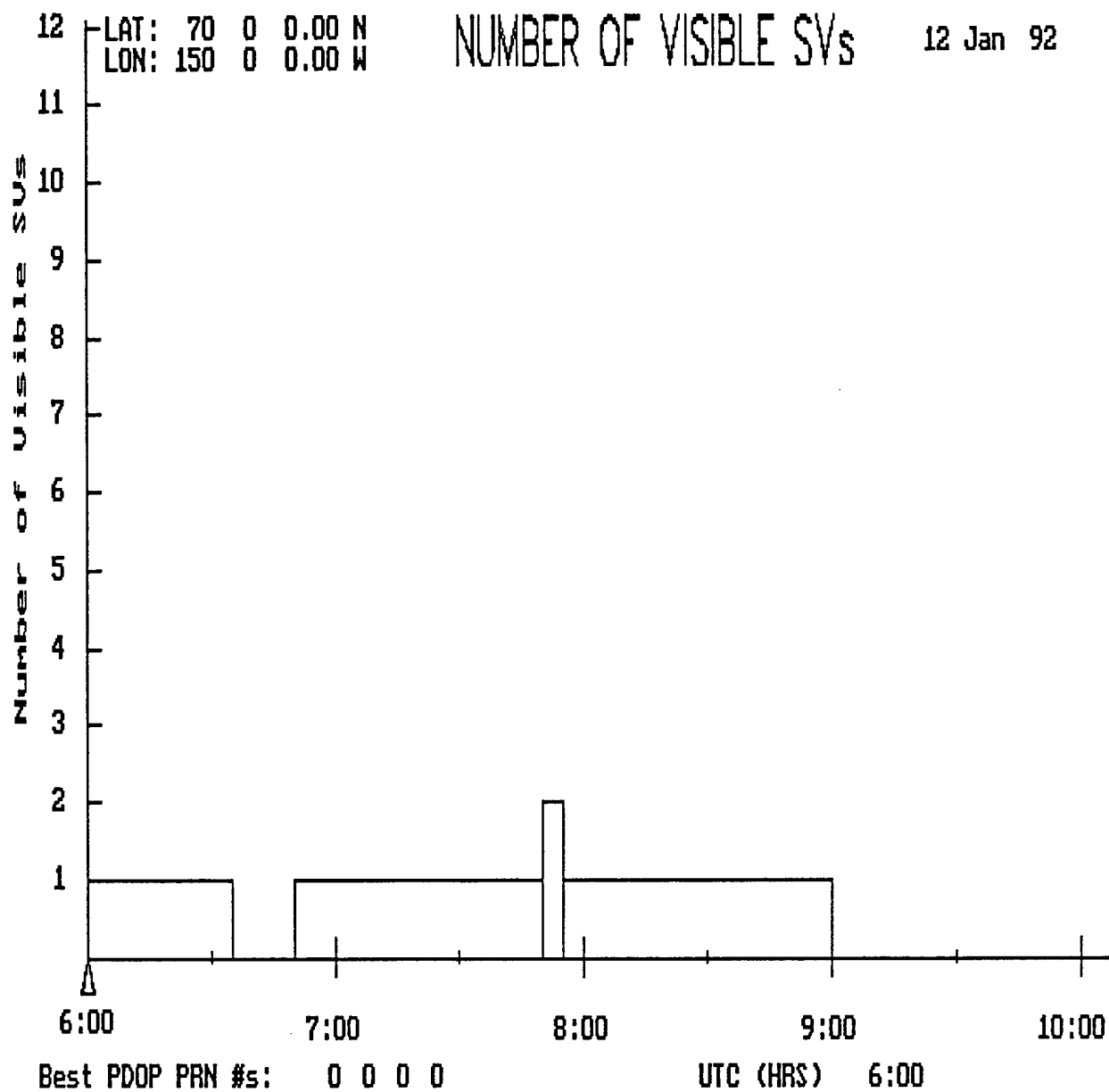

Figure A-41. Number of Visible GPS Satellites At High-Latitudes. Mask Angle of 60 Degrees.

NO SOLUTION FOR PDOP SINCE NOT ENOUGH SATELLITES ARE VISIBLE

Figure A-42. GPS PDOP At High-Latitudes.
Mask Angle of 60 Degrees.

III. GLONASS-ONLY OPERATION FOR 3 HOURS

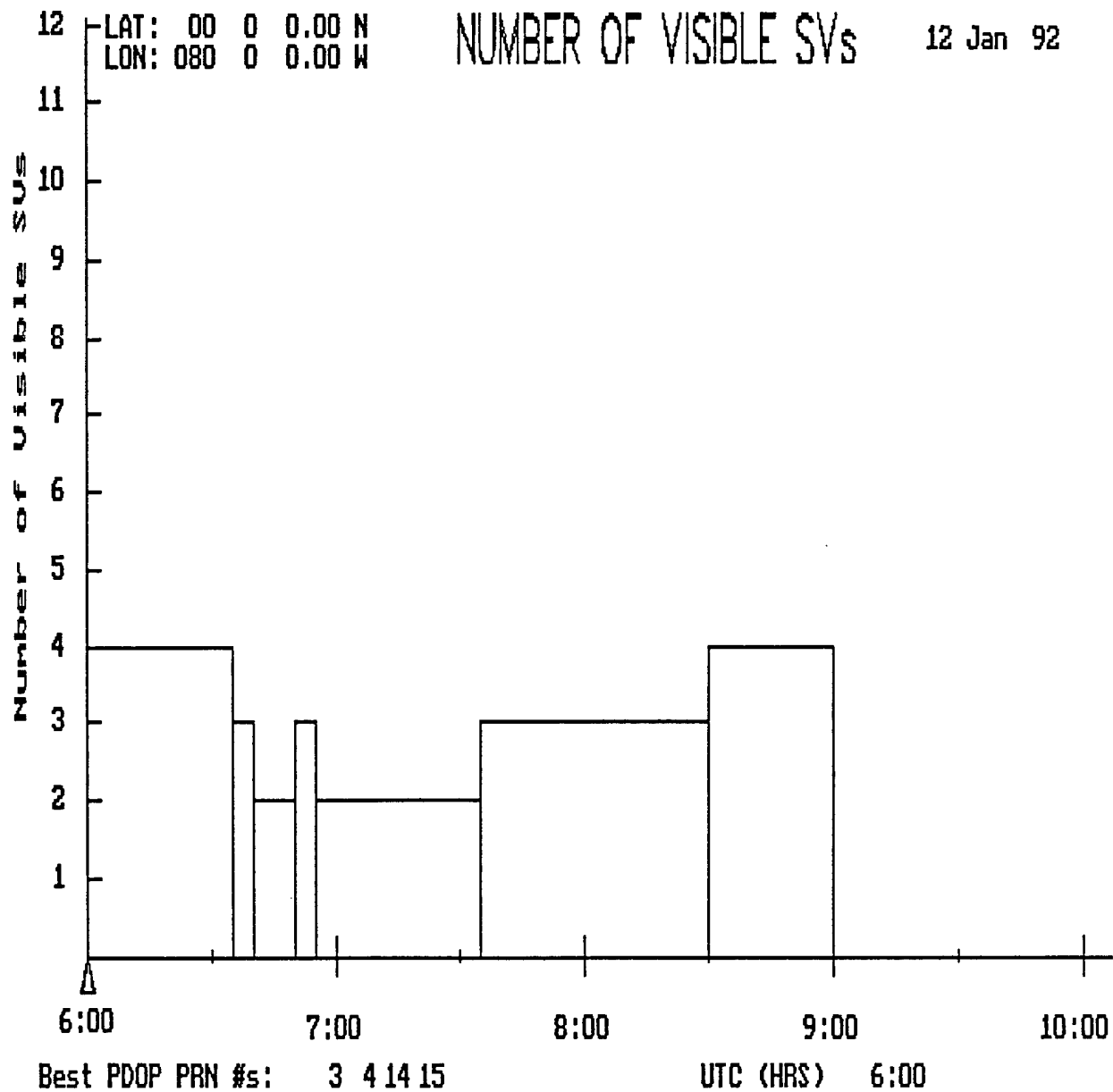

Figure A-43. Number of Visible GLONASS Satellites At Low-Latitudes. Mask Angle of 30 Degrees.

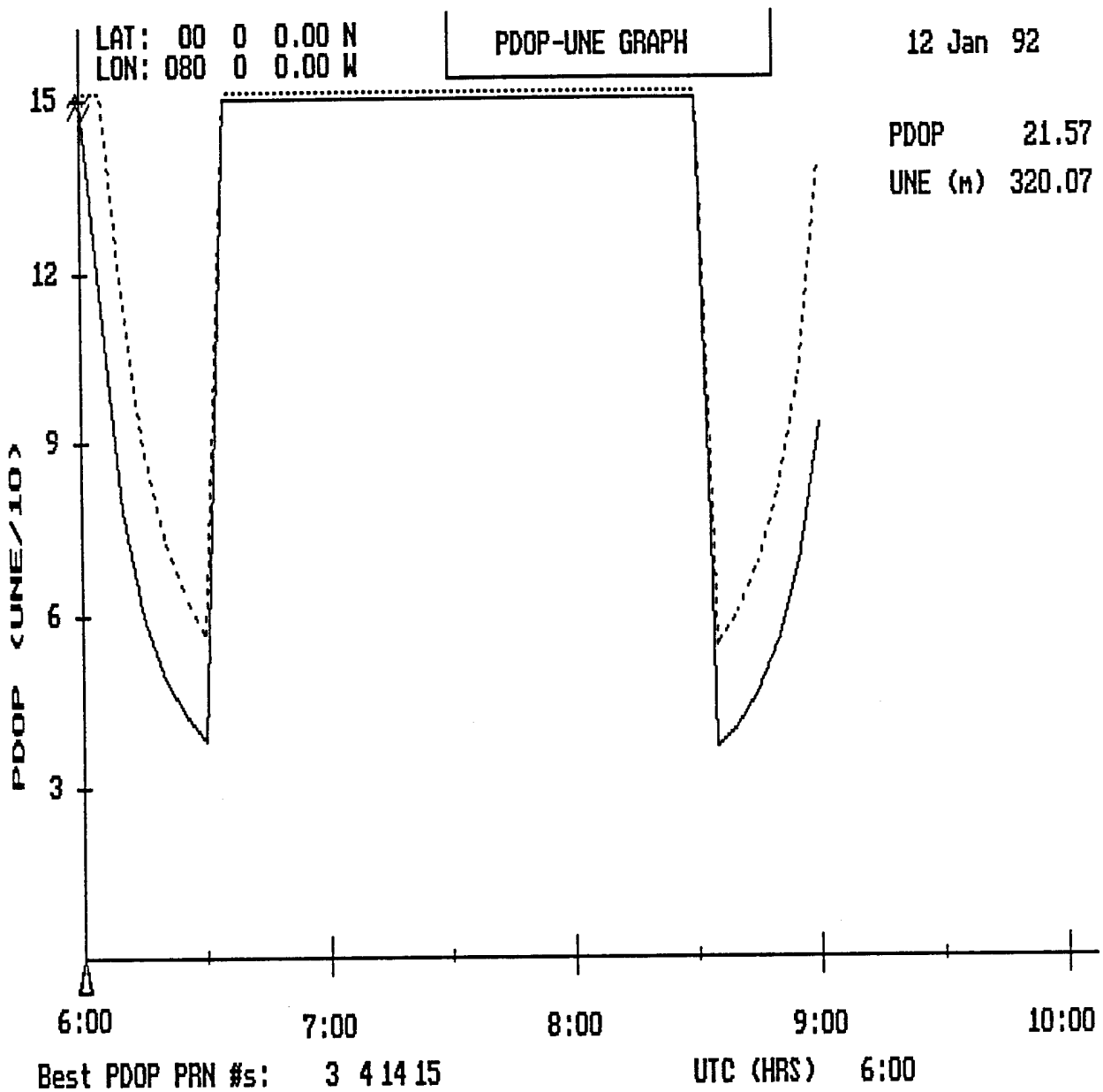

Figure A-44. GLONASS PDOP At Low-Latitudes.
Mask Angle of 30 Degrees.

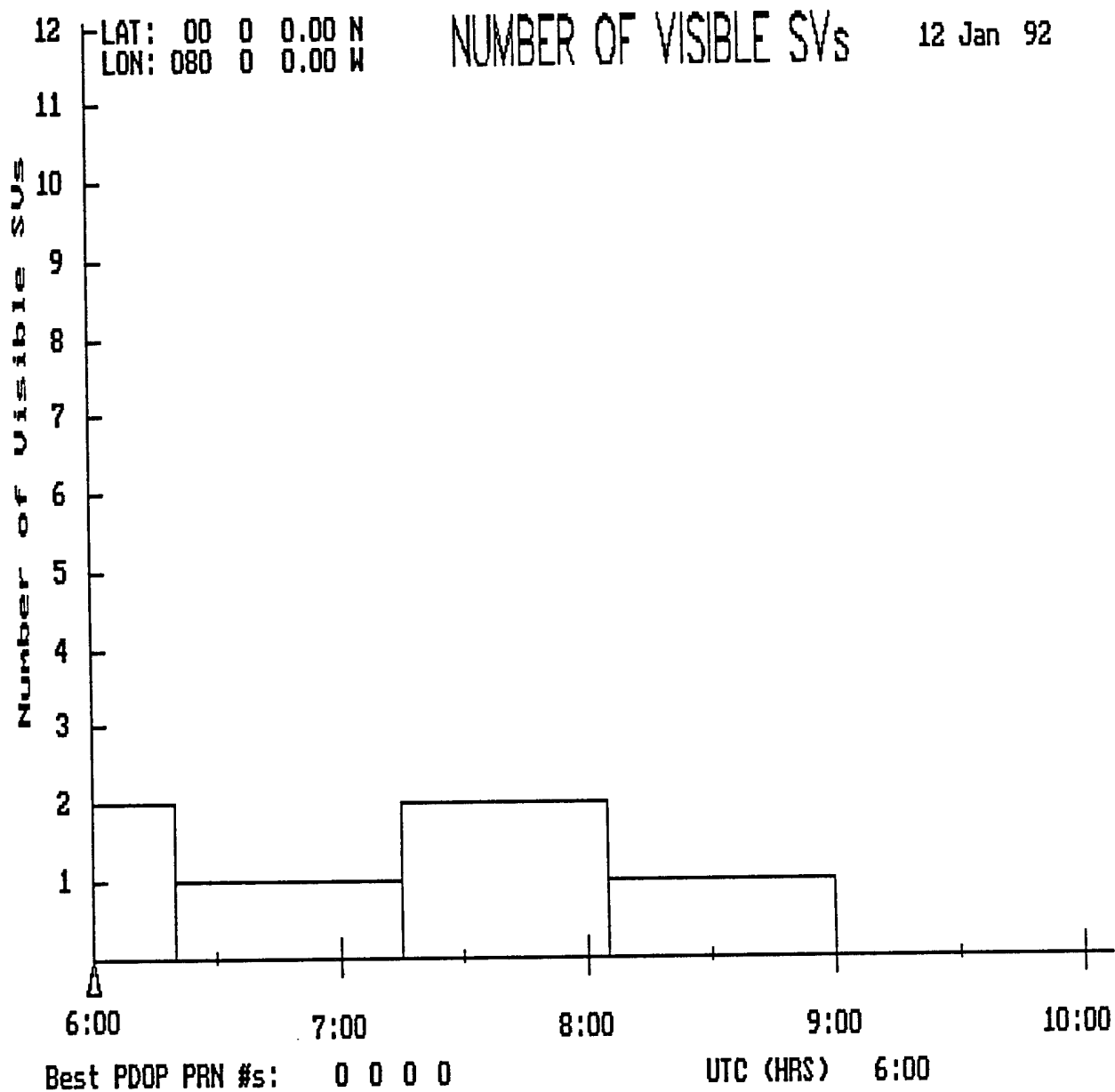

Figure A-45. Number of Visible GLONASS Satellites At Low-Latitudes. Mask Angle of 45 Degrees.

NO SOLUTION FOR PDOP SINCE NOT ENOUGH SATELLITES ARE VISIBLE

Figure A-46. GLONASS PDOP At Low-Latitudes.
Mask Angle of 45 Degrees.

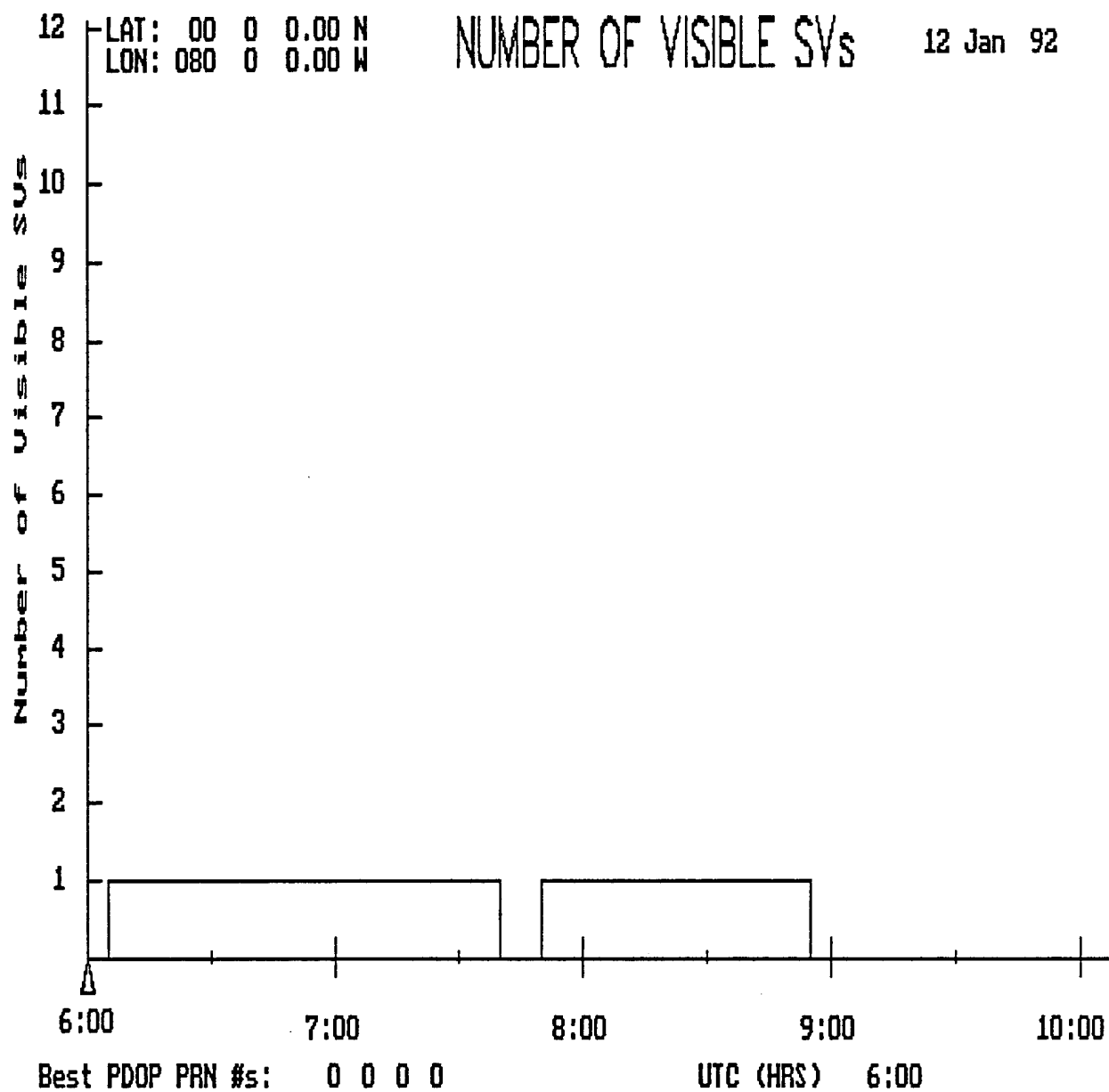

Figure A-47. Number of Visible GLONASS Satellites At Low-Latitudes. Mask Angle of 60 Degrees.

NO SOLUTION FOR PDOP SINCE NOT ENOUGH SATELLITES ARE VISIBLE

Figure A-48. GLONASS PDOP At Low-Latitudes.
Mask Angle of 60 Degrees.

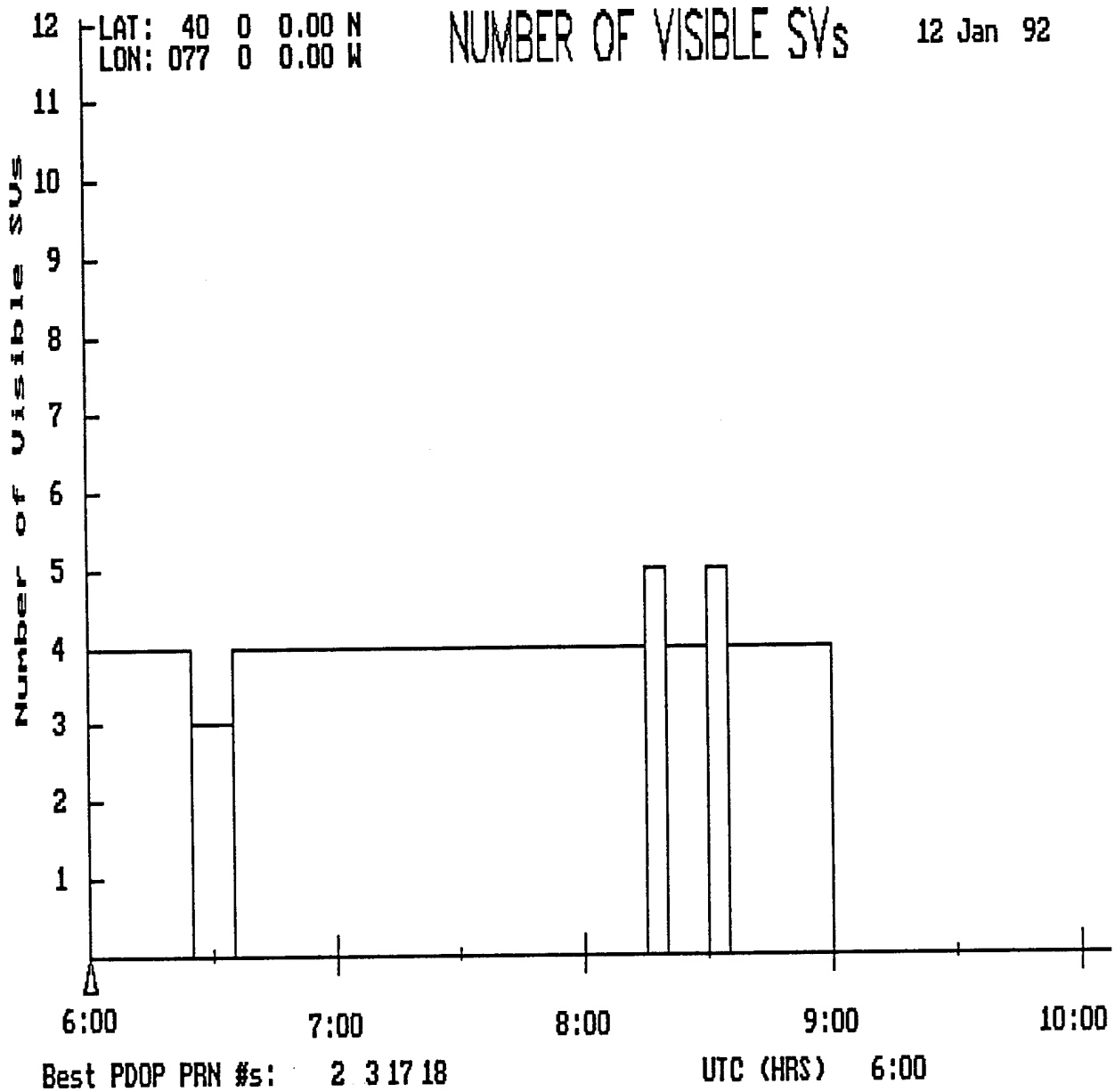

Figure A-49. Number of Visible GLONASS Satellites At Mid-Latitudes. Mask Angle of 30 Degrees.

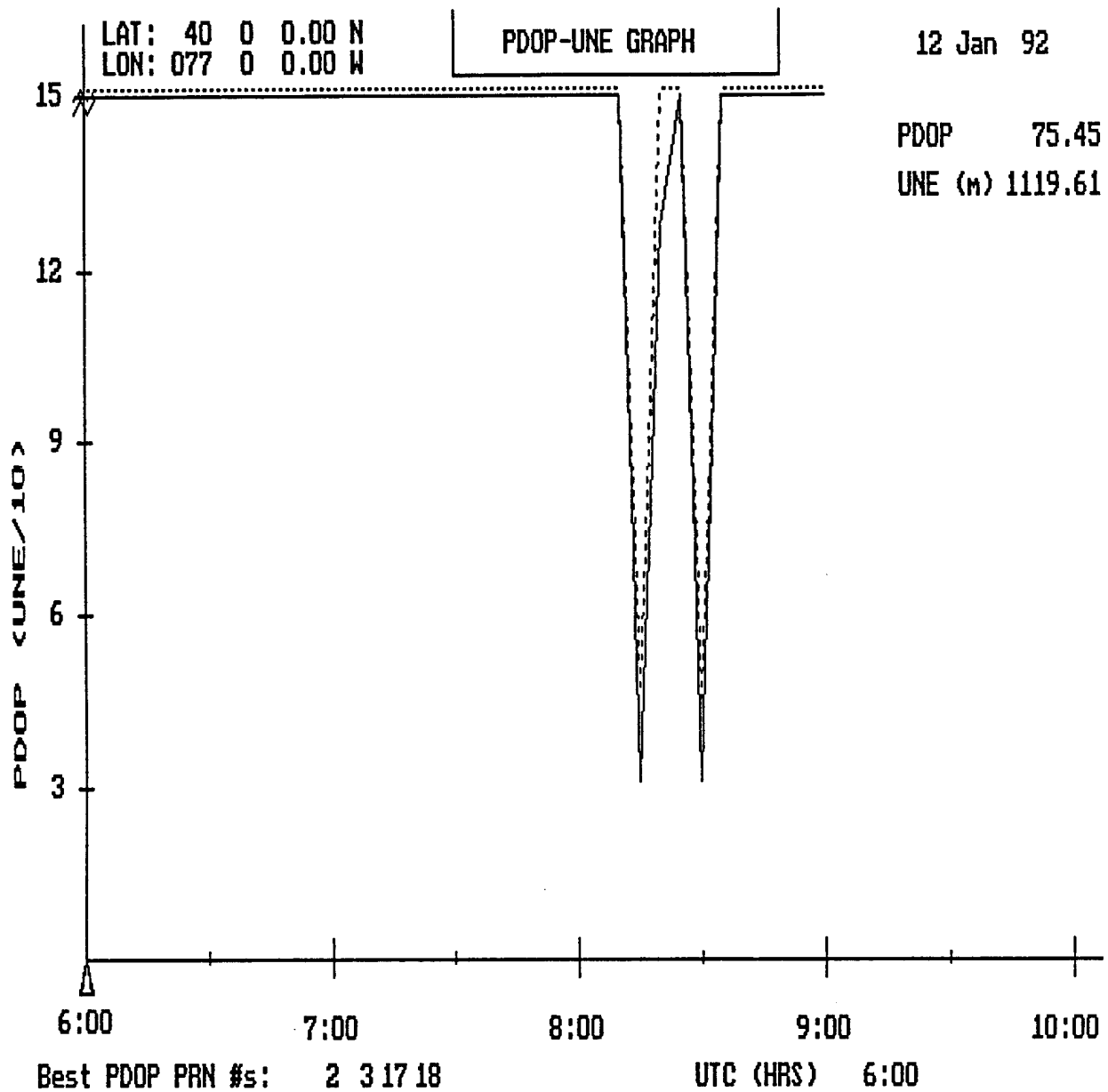

Figure A-50. GLONASS PDOP At Mid-Latitudes.
Mask Angle of 30 Degrees.

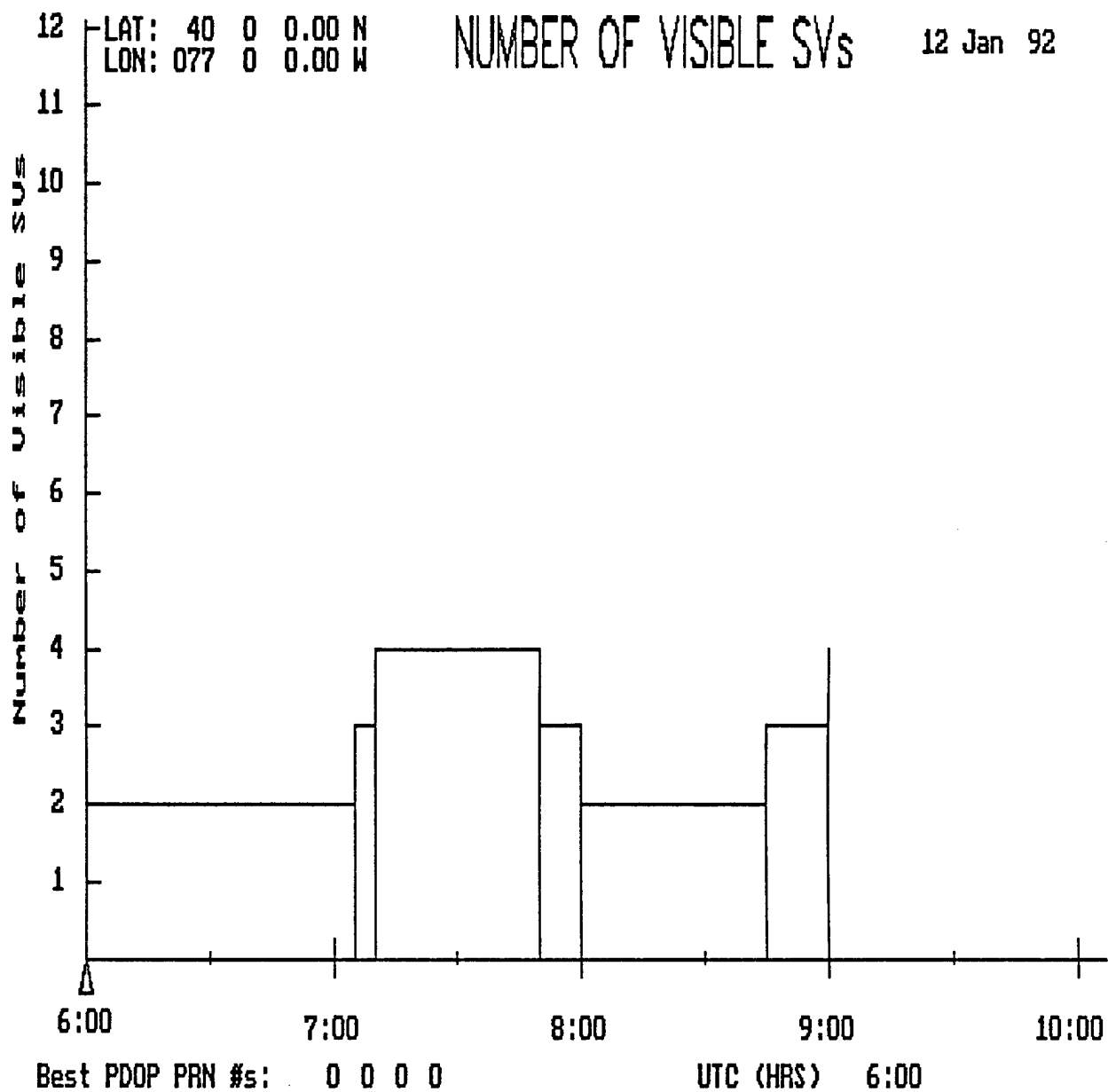

Figure A-51. Number of Visible GLONASS Satellites At Mid-Latitudes. Mask Angle of 45 Degrees.

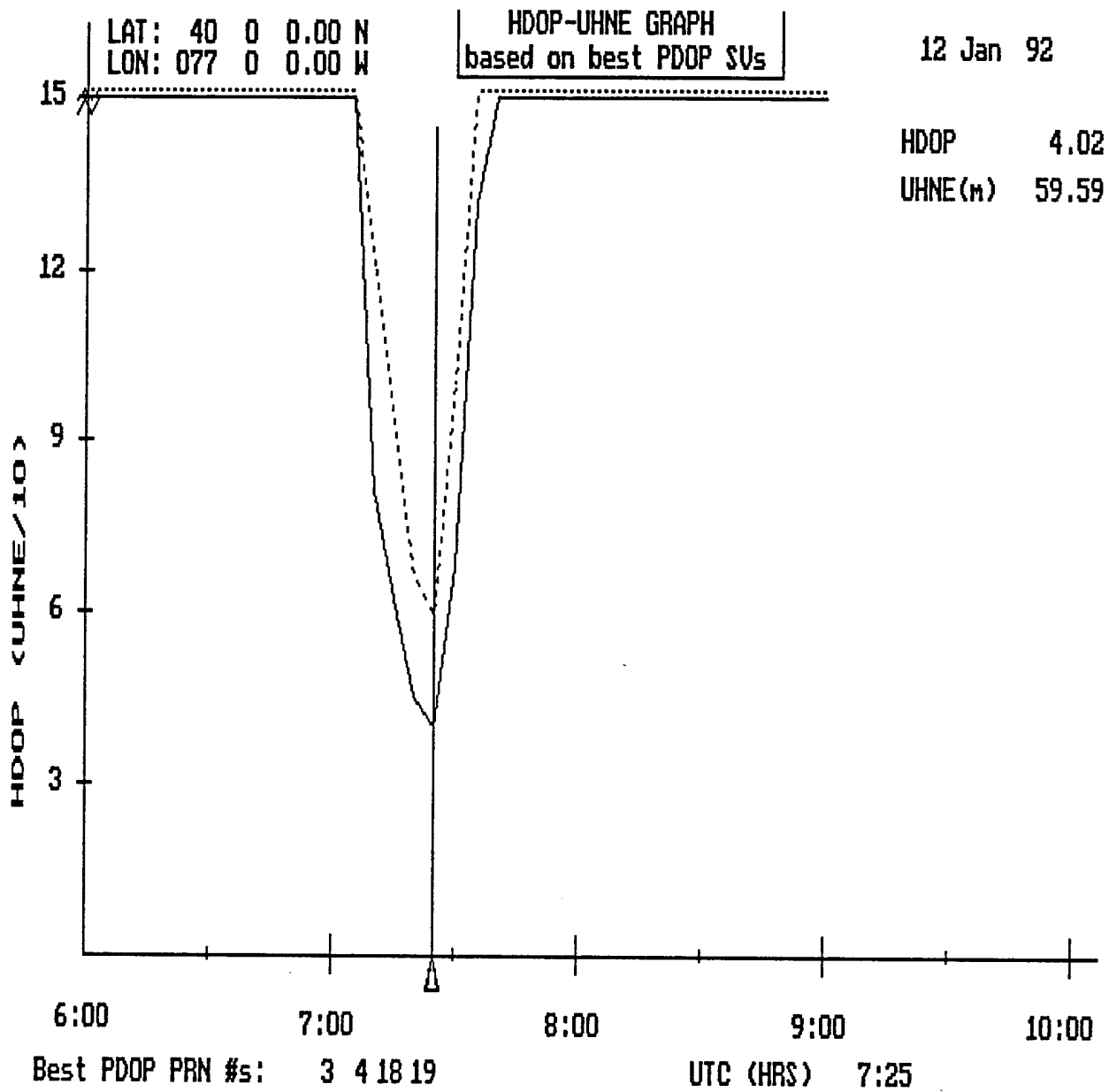

Figure A-52. GLONASS HDOP At Mid-Latitudes.
 Mask Angle of 45 Degrees. (NO PDOP SOLUTION)

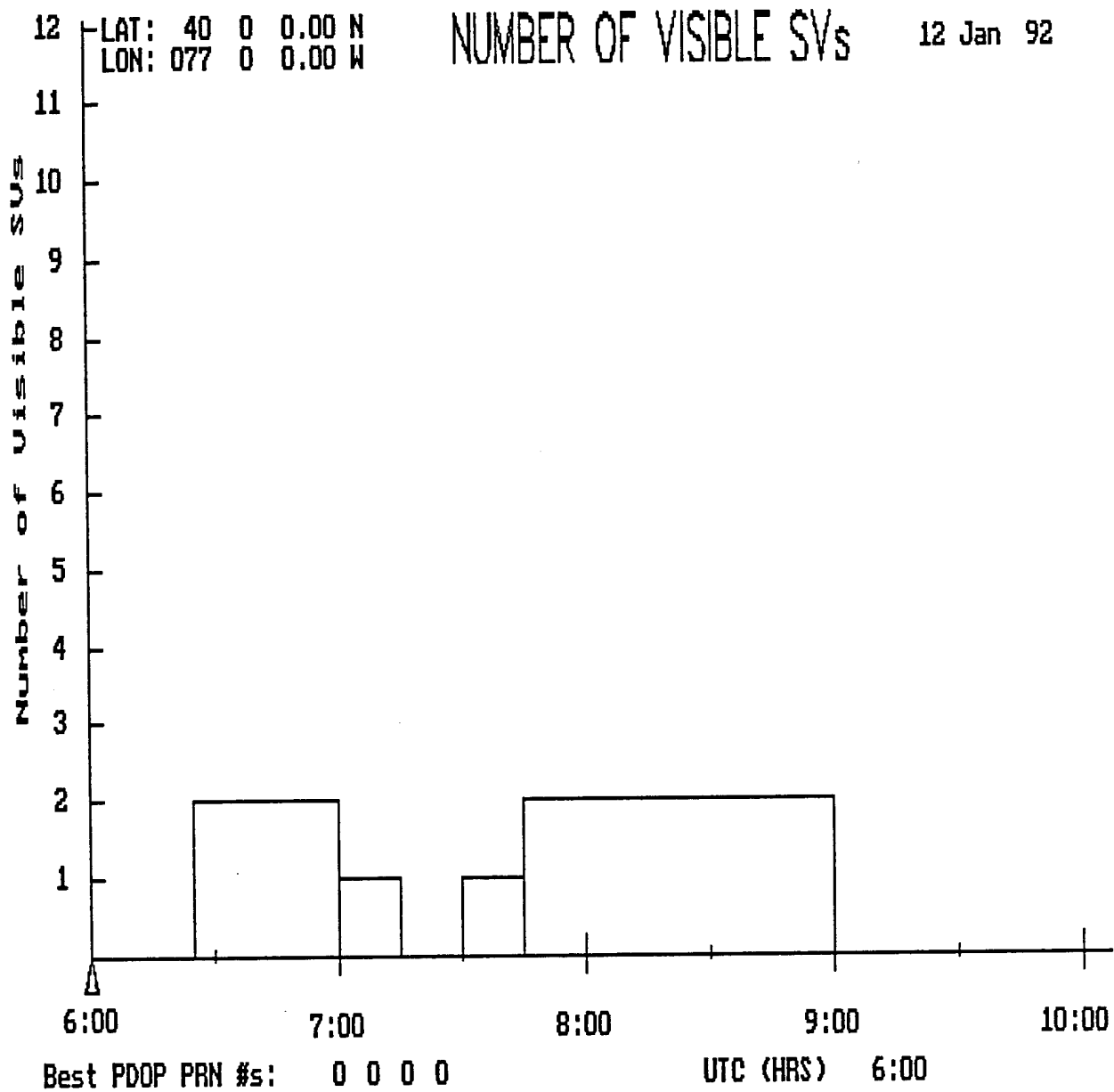

Figure A-53. Number of Visible GLONASS Satellites At Mid-Latitudes. Mask Angle of 60 Degrees.

NO SOLUTION FOR PDOP SINCE NOT ENOUGH SATELLITES ARE VISIBLE

Figure A-54. GLONASS PDOP At Mid-Latitudes.
Mask Angle of 60 Degrees.

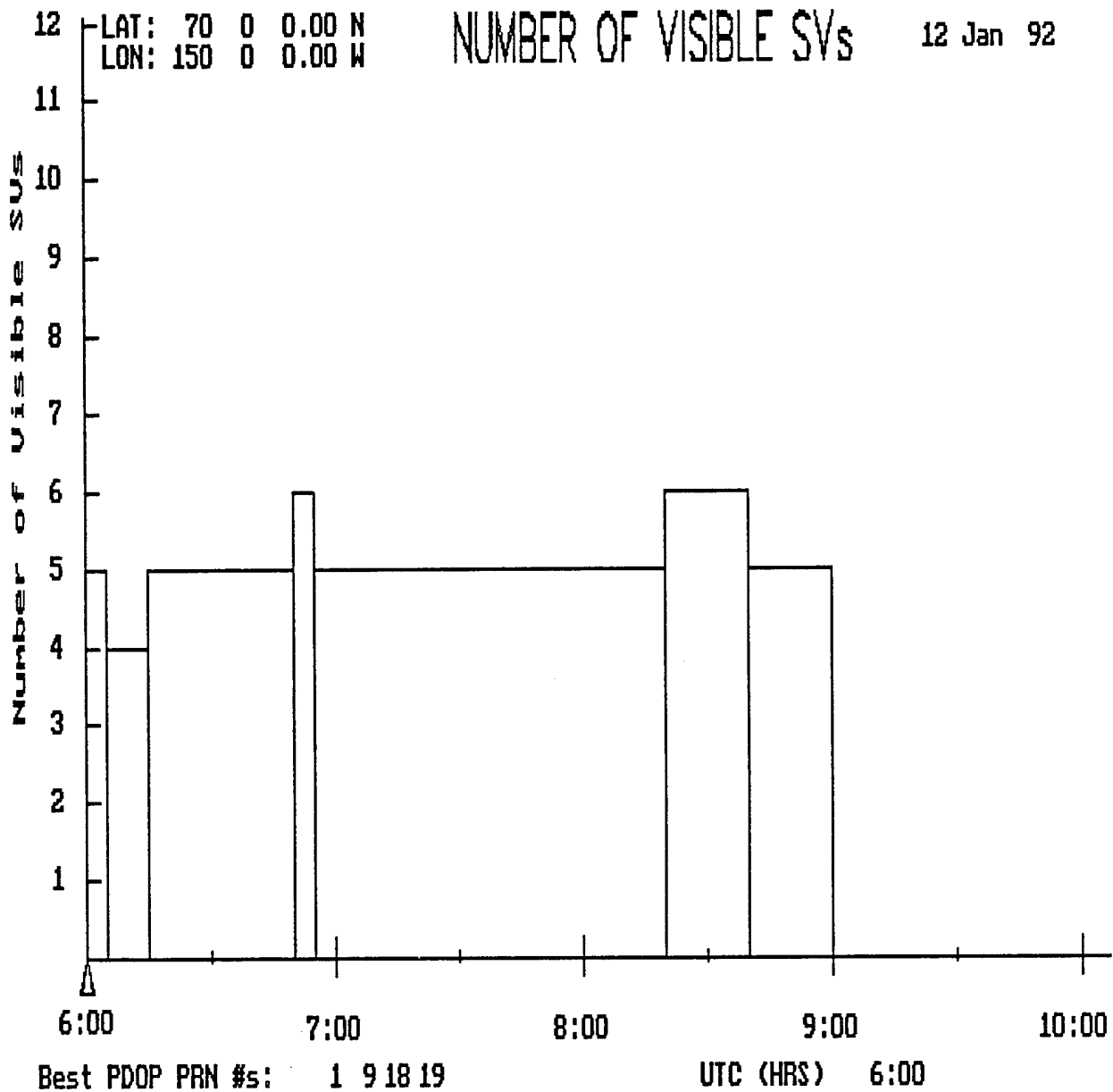

Figure A-55. Number of Visible GLONASS Satellites At High-Latitudes. Mask Angle of 30 Degrees.

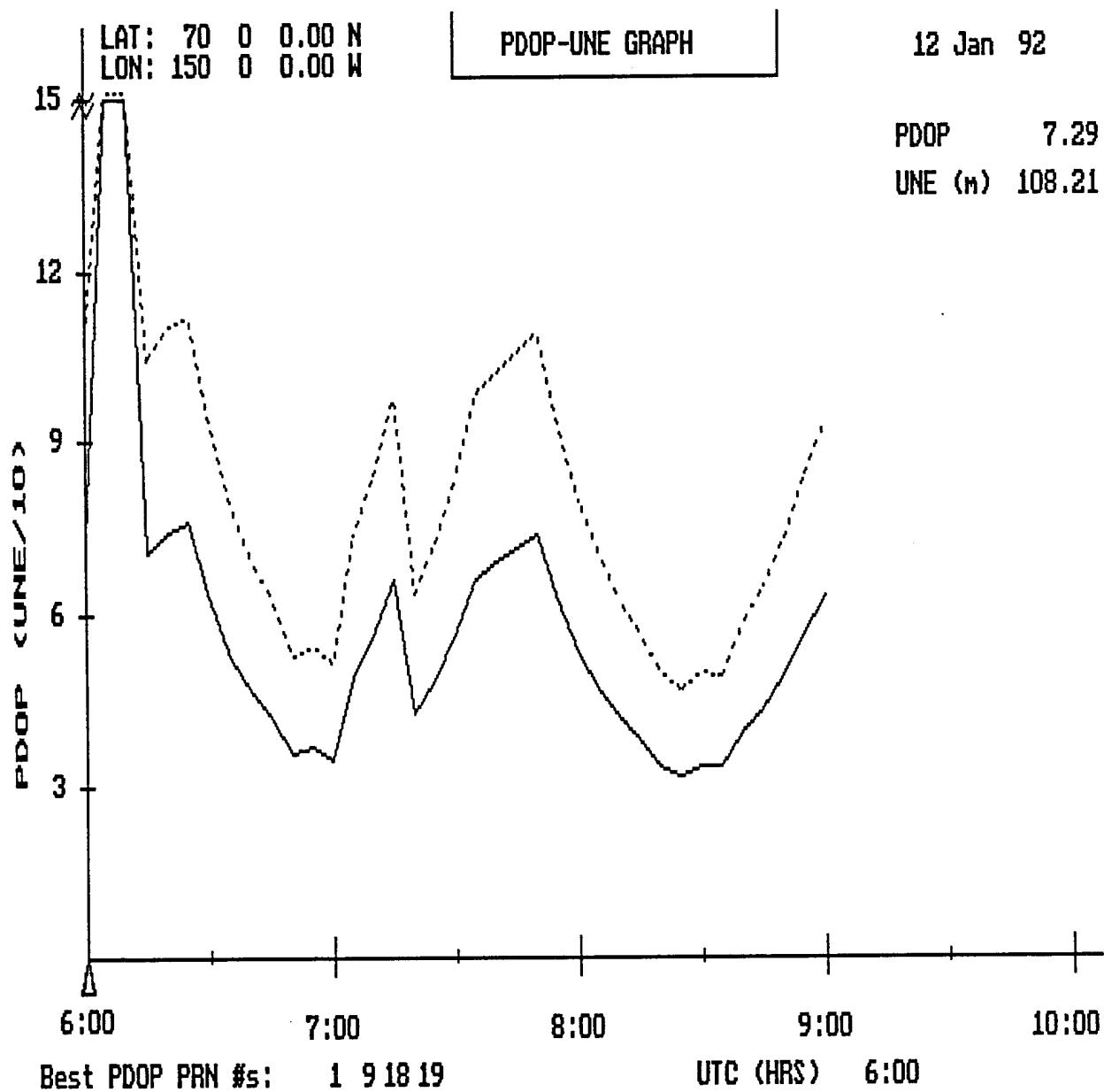

Figure A-56. GLONASS PDOP At High-Latitudes.
Mask Angle of 30 Degrees.

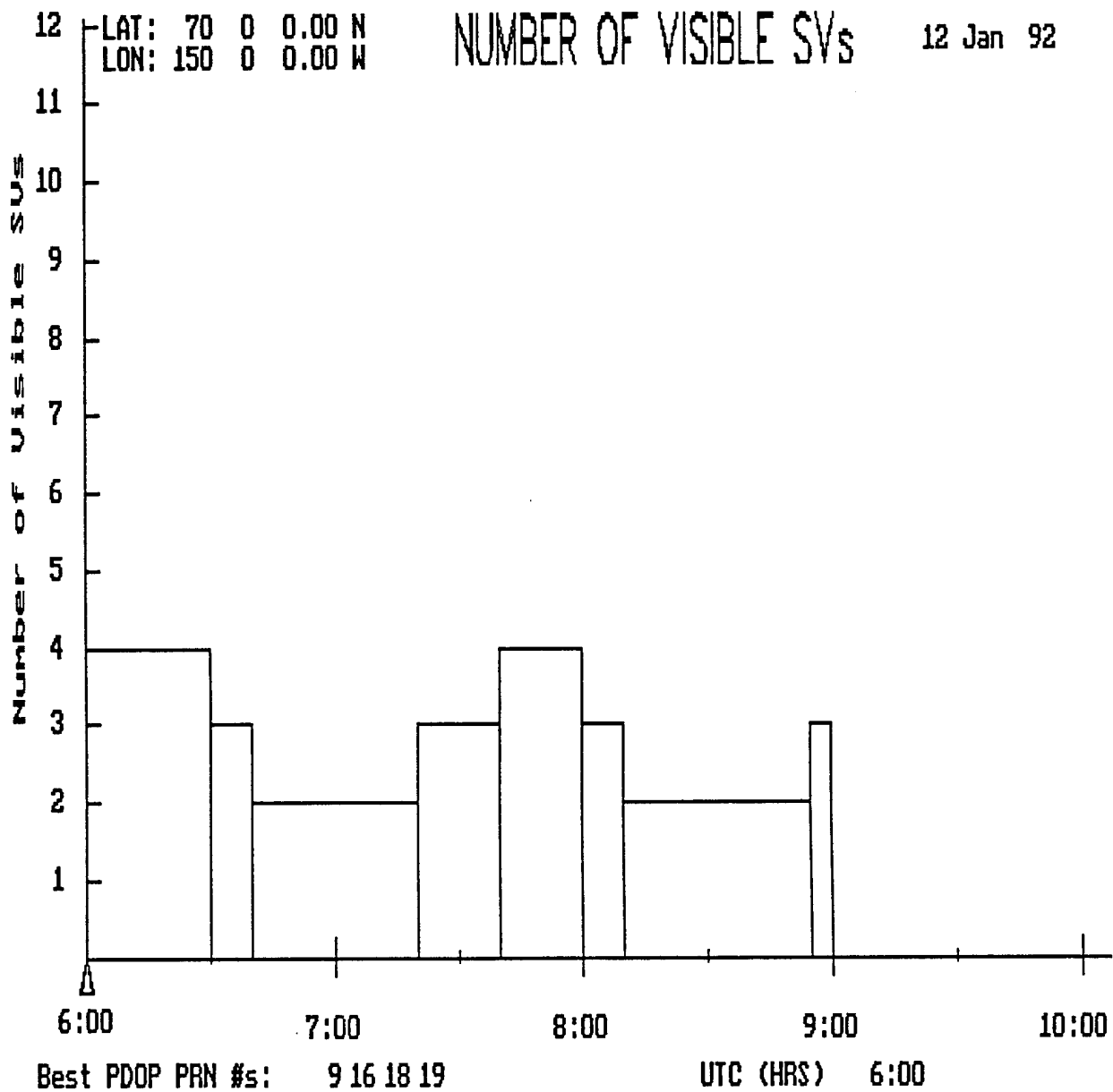

Figure A-57. Number of Visible GLONASS Satellites At High-Latitudes. Mask Angle of 45 Degrees.

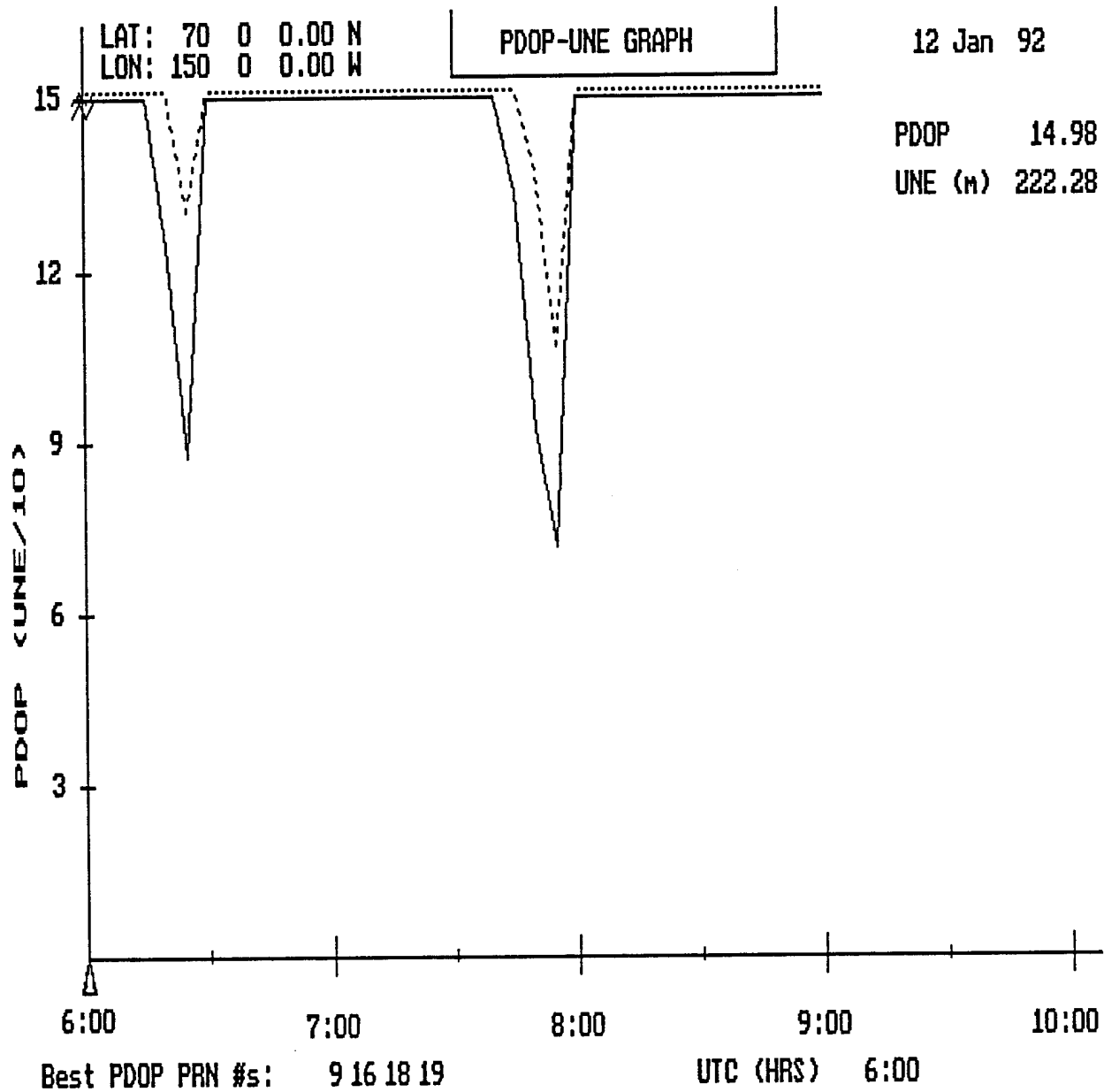

Figure A-58. GLONASS PDOP At High-Latitudes.
Mask Angle of 45 Degrees.

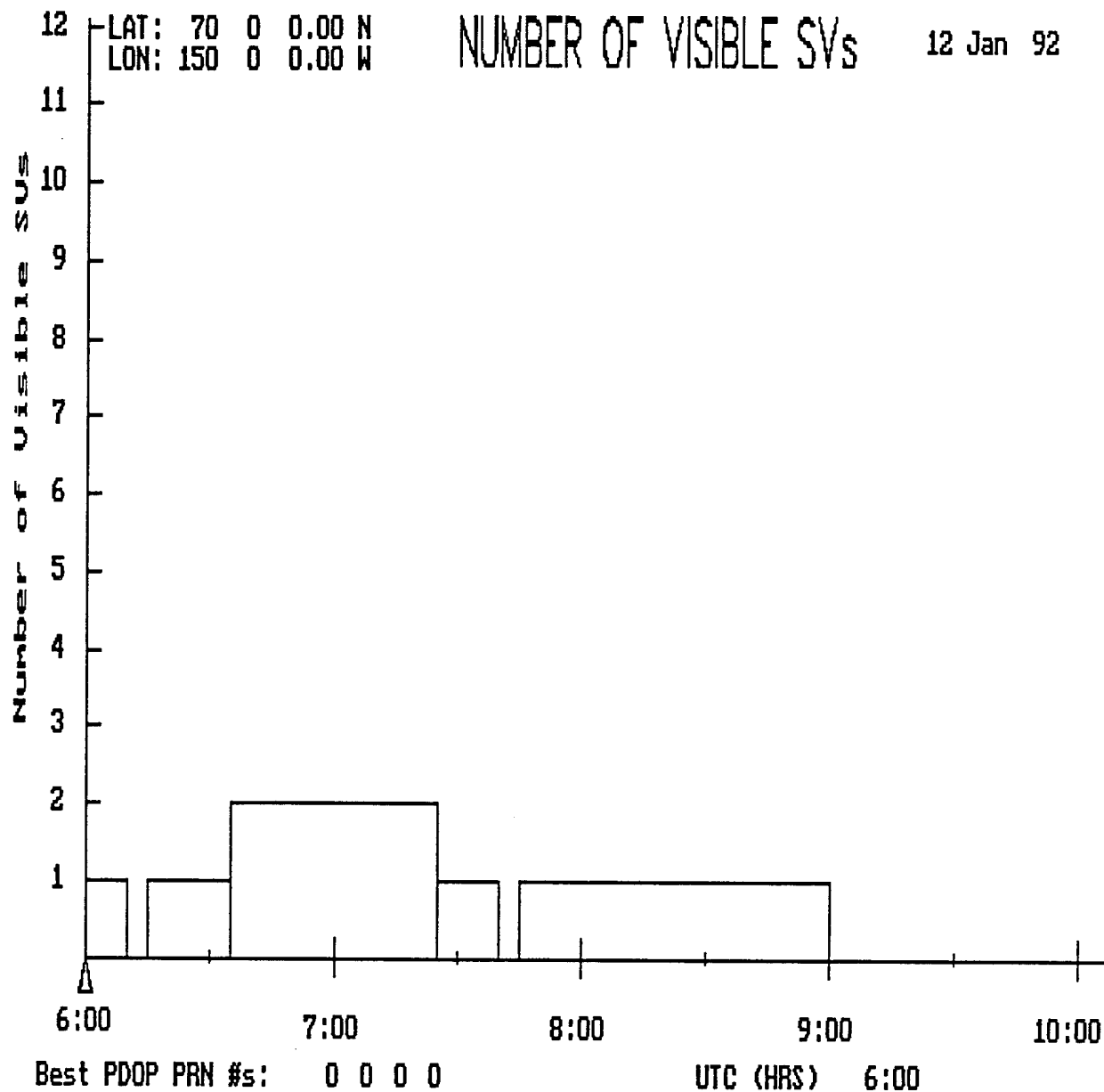

Figure A-59. Number of Visible GLONASS Satellites At High-Latitudes. Mask Angle of 60 Degrees.

NO SOLUTION FOR PDOP SINCE NOT ENOUGH SATELLITES ARE VISIBLE

Figure A-60. GLONASS PDOP At High-Latitudes.
Mask Angle of 60 Degrees.

6.2 APPENDIX B.
RESULTS WITH DUAL GPS/GLONASS FULL
CONSTELLATIONS

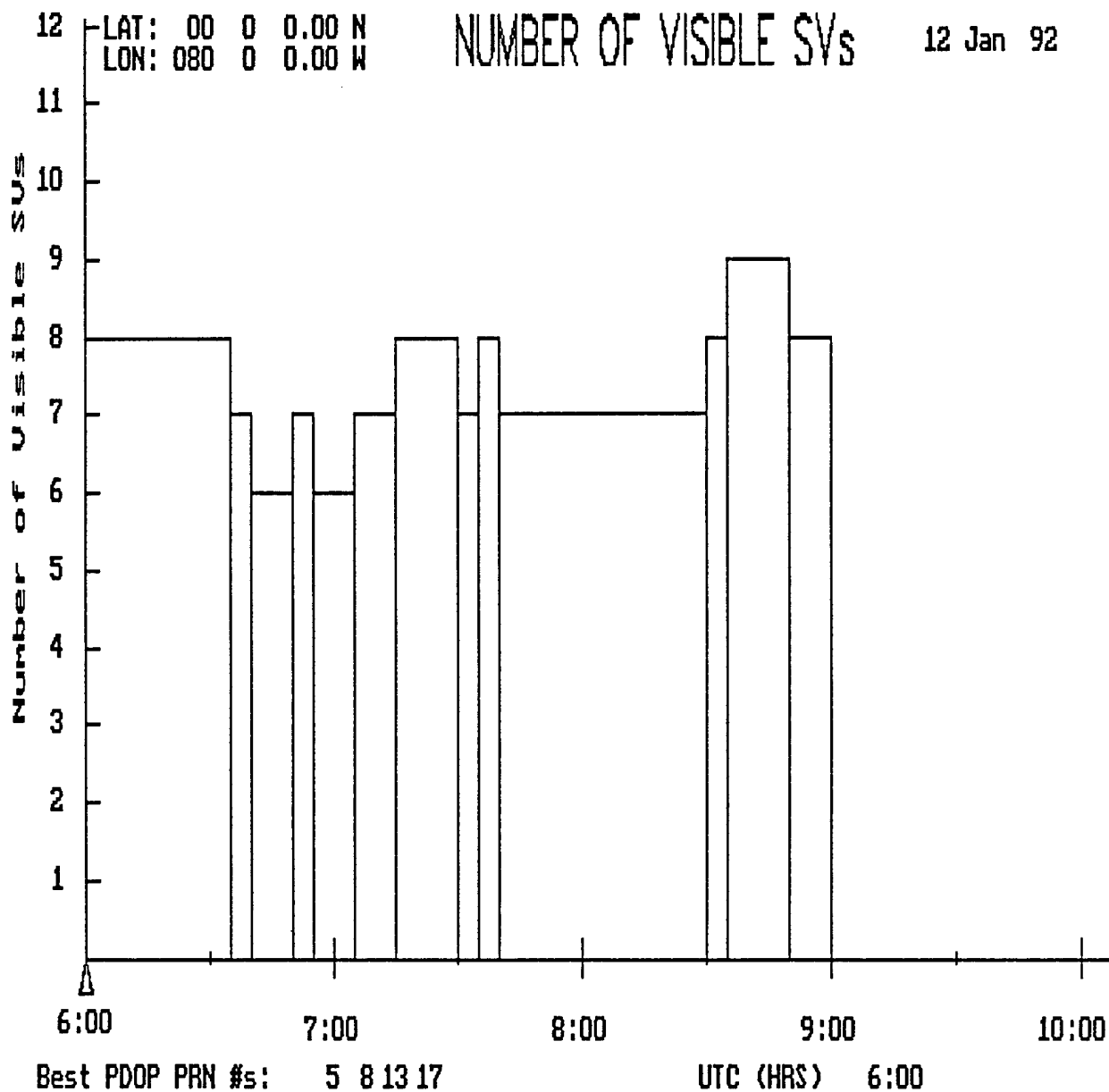

Figure B-1. Number of Visible Satellites At Low-Latitudes.
Mask Angle of 30 Degrees.

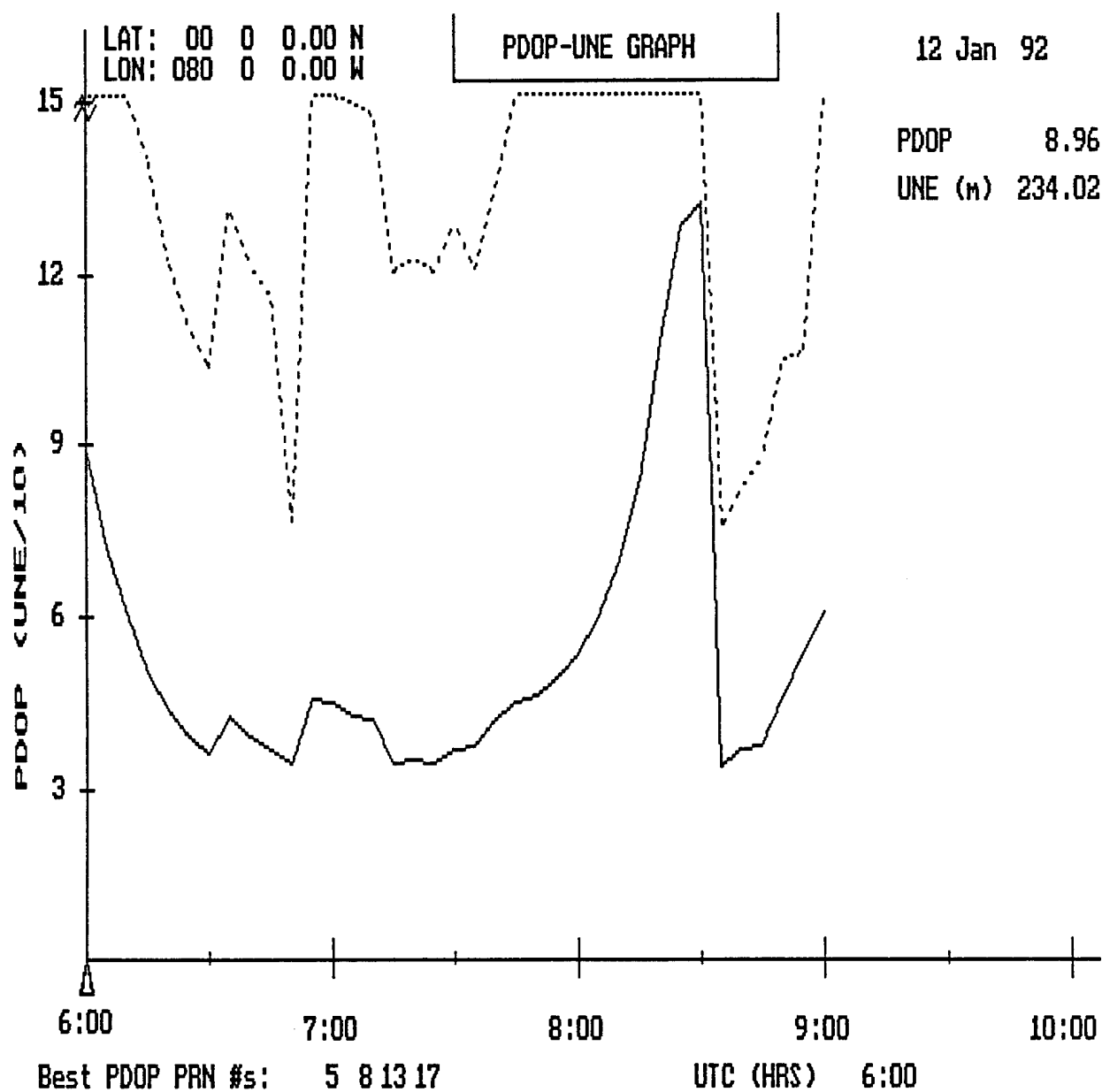

Figure B-2. PDOP At Low-Latitudes.
Mask Angle of 30 Degrees.

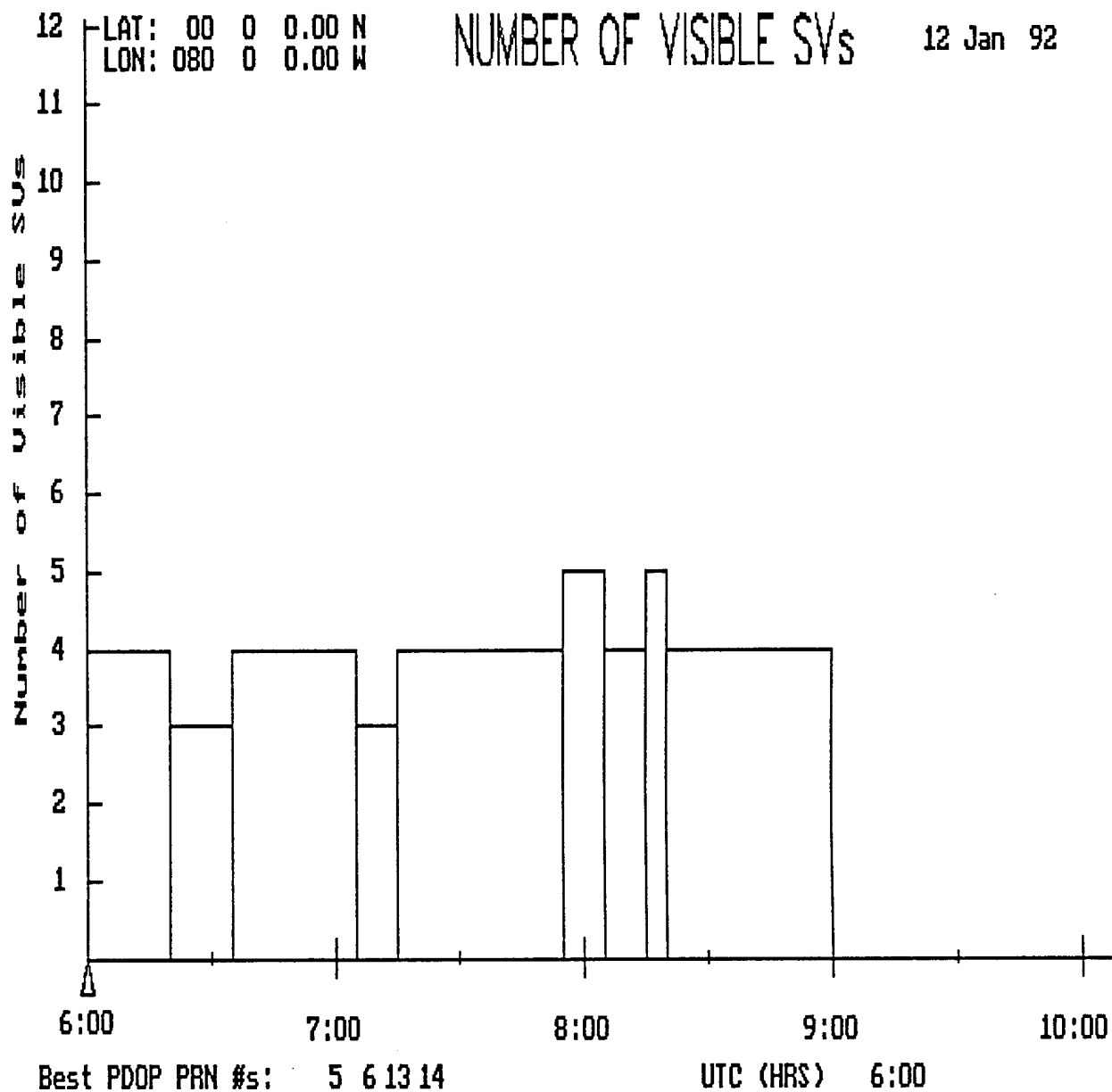

Figure B-3. Number of Visible Satellites At Low-Latitudes.
Mask Angle of 45 Degrees.

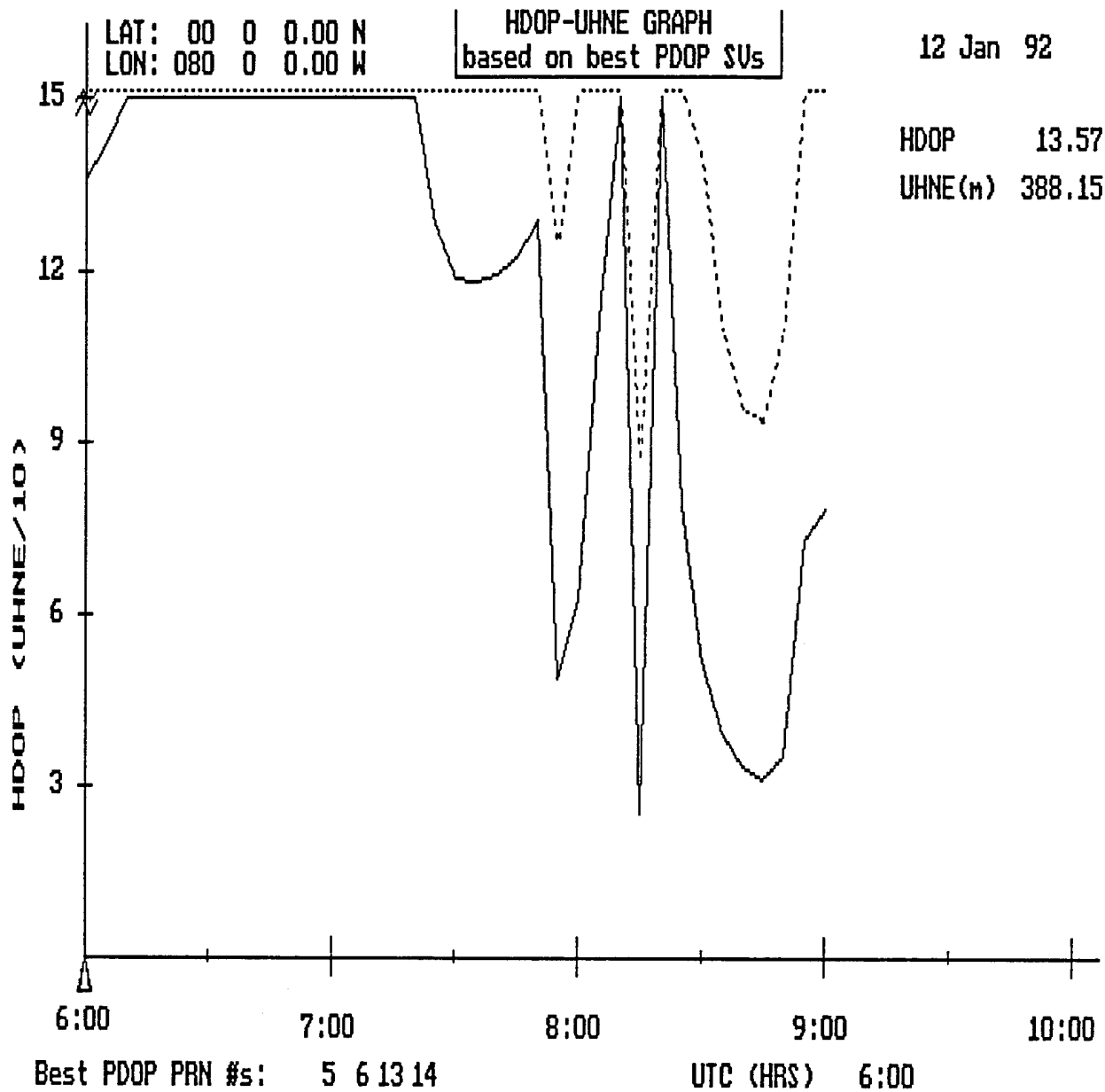

Figure B-4. HDOP At Low-Latitudes.
Mask Angle of 45 Degrees. (PDOP SOLUTION POOR)

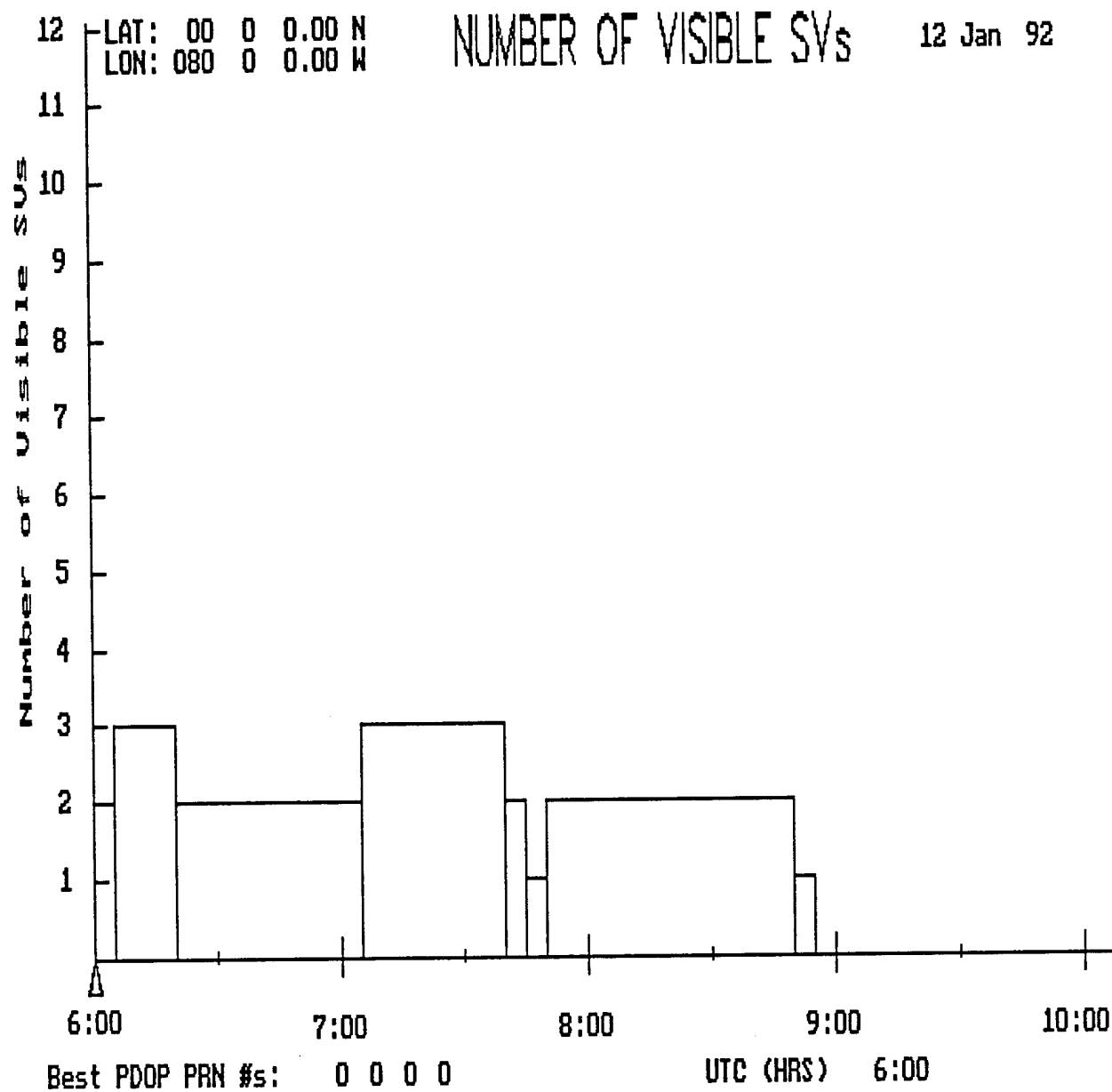

Figure B-5. Number of Visible Satellites At Low-Latitudes.
Mask Angle of 60 Degrees.

NO SOLUTION FOR PDOP SINCE NOT ENOUGH SATELLITES ARE VISIBLE

Figure B-6. PDOP At Low-Latitudes.
Mask Angle of 60 Degrees.

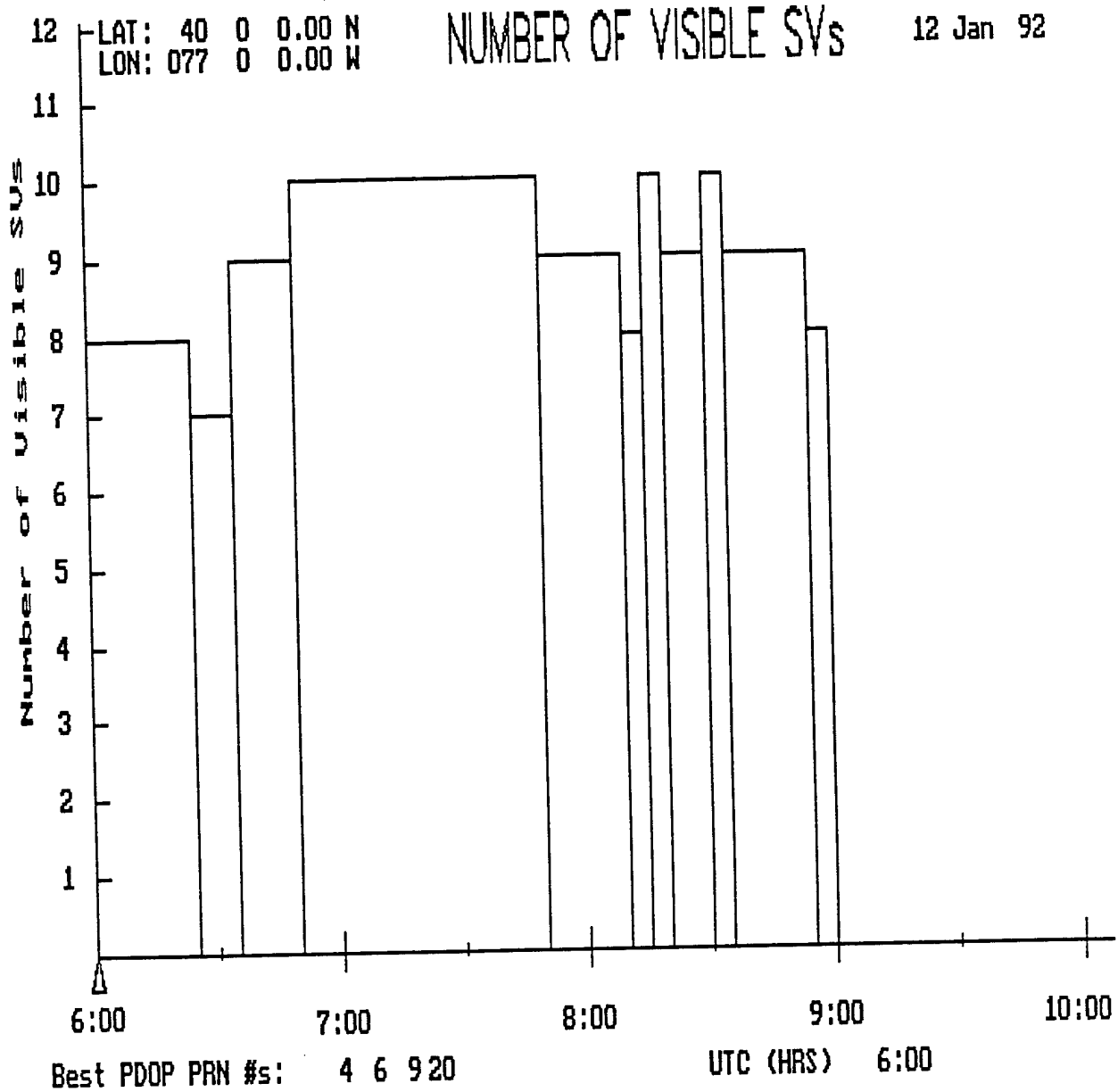

Figure B-7. Number of Visible Satellites At Mid-Latitudes.
Mask Angle of 30 Degrees.

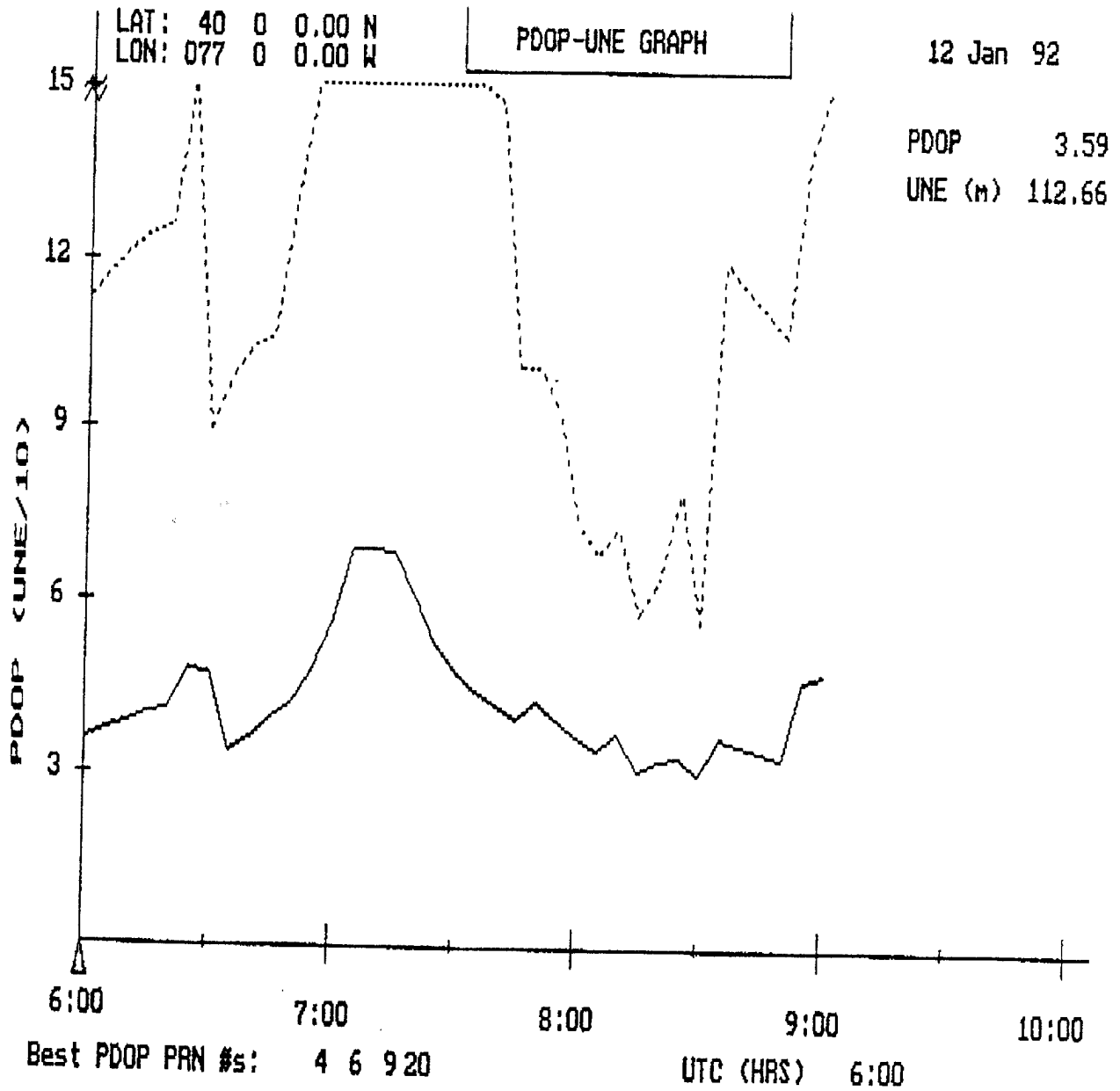

Figure B-8. PDOP At Mid-Latitudes.
Mask Angle of 30 Degrees.

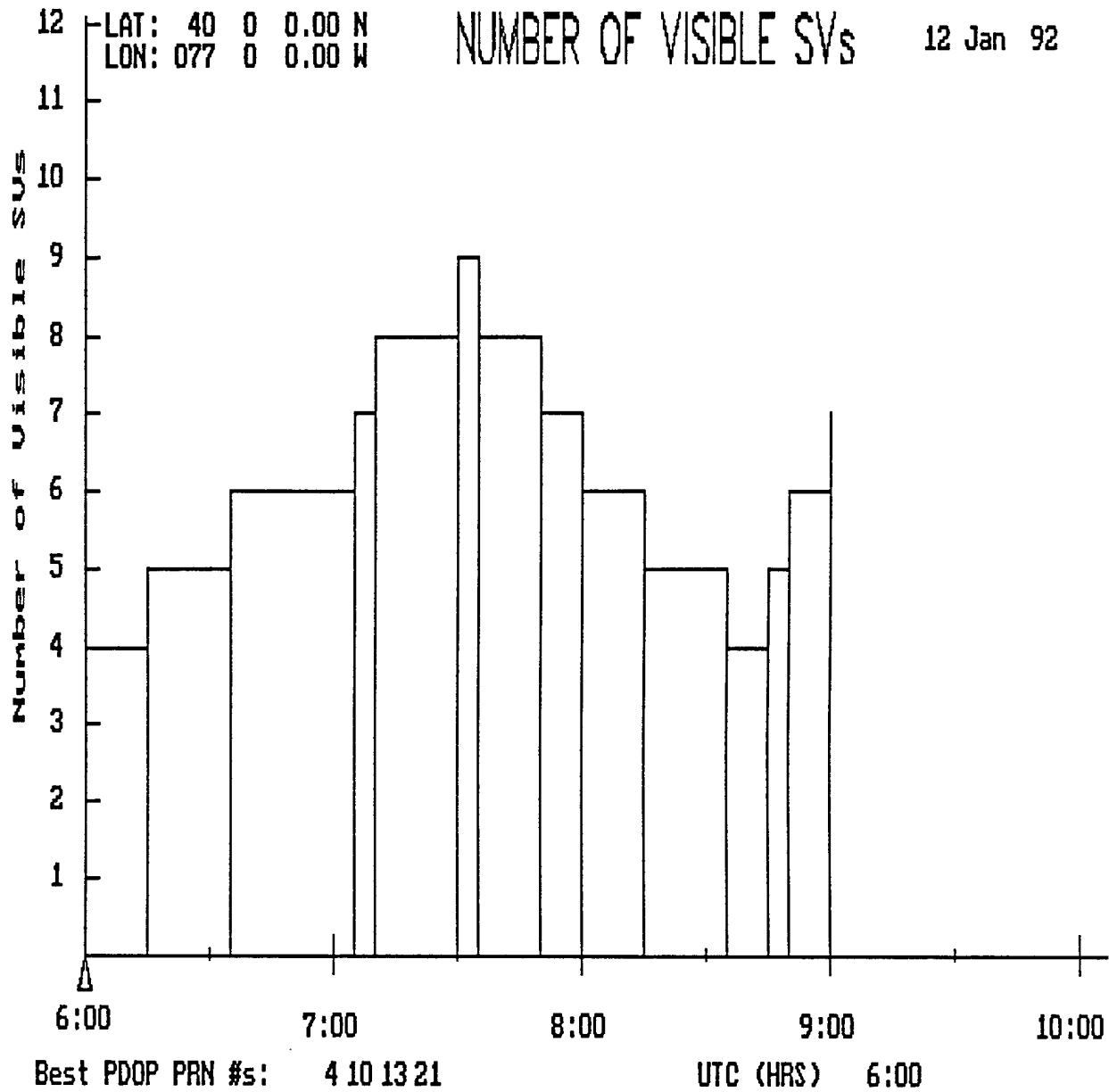

Figure B-9. Number of Visible Satellites At Mid-Latitudes.
Mask Angle of 45 Degrees.

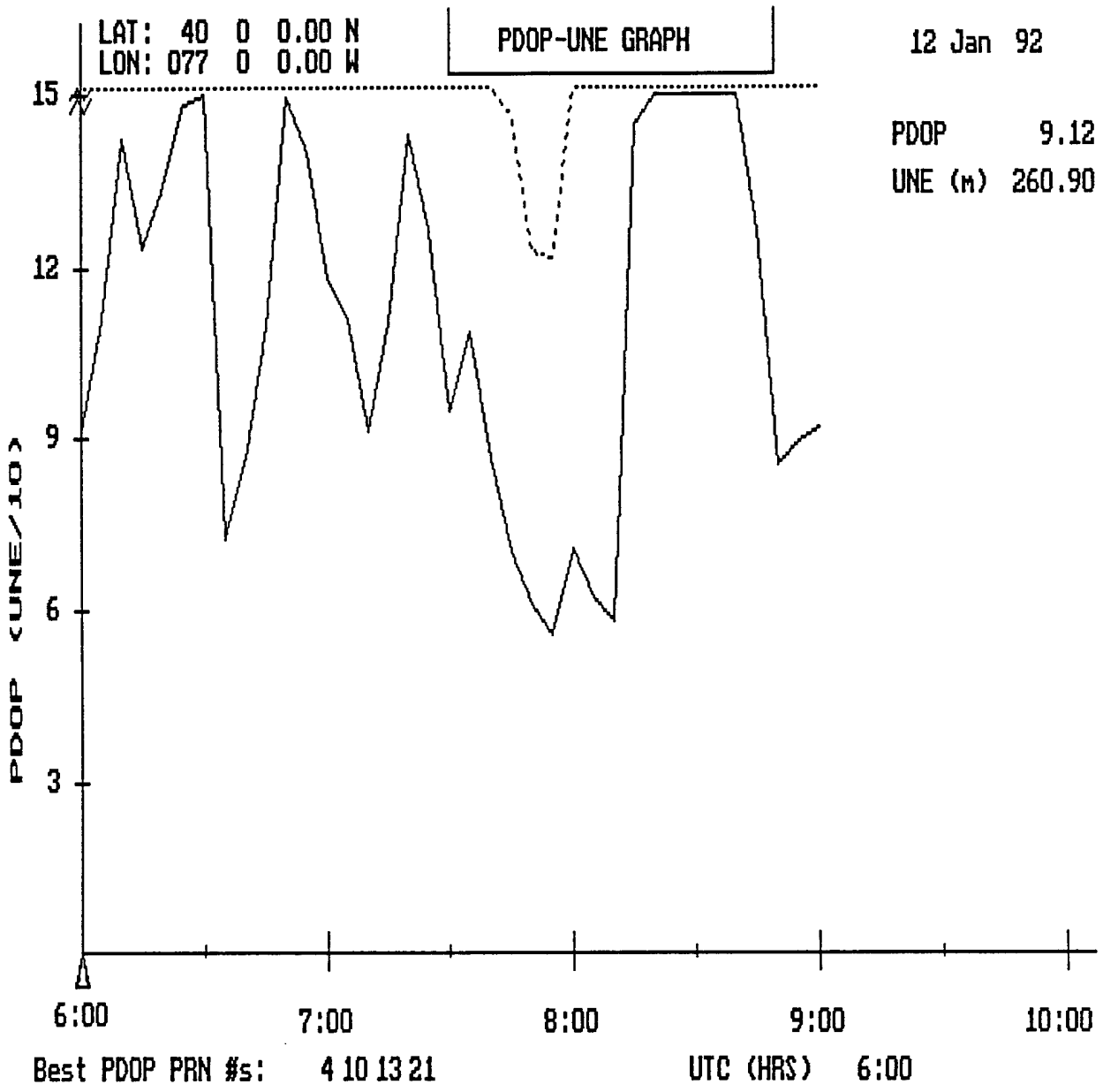

Figure B-10. PDOP At Mid-Latitudes.
Mask Angle of 45 Degrees.

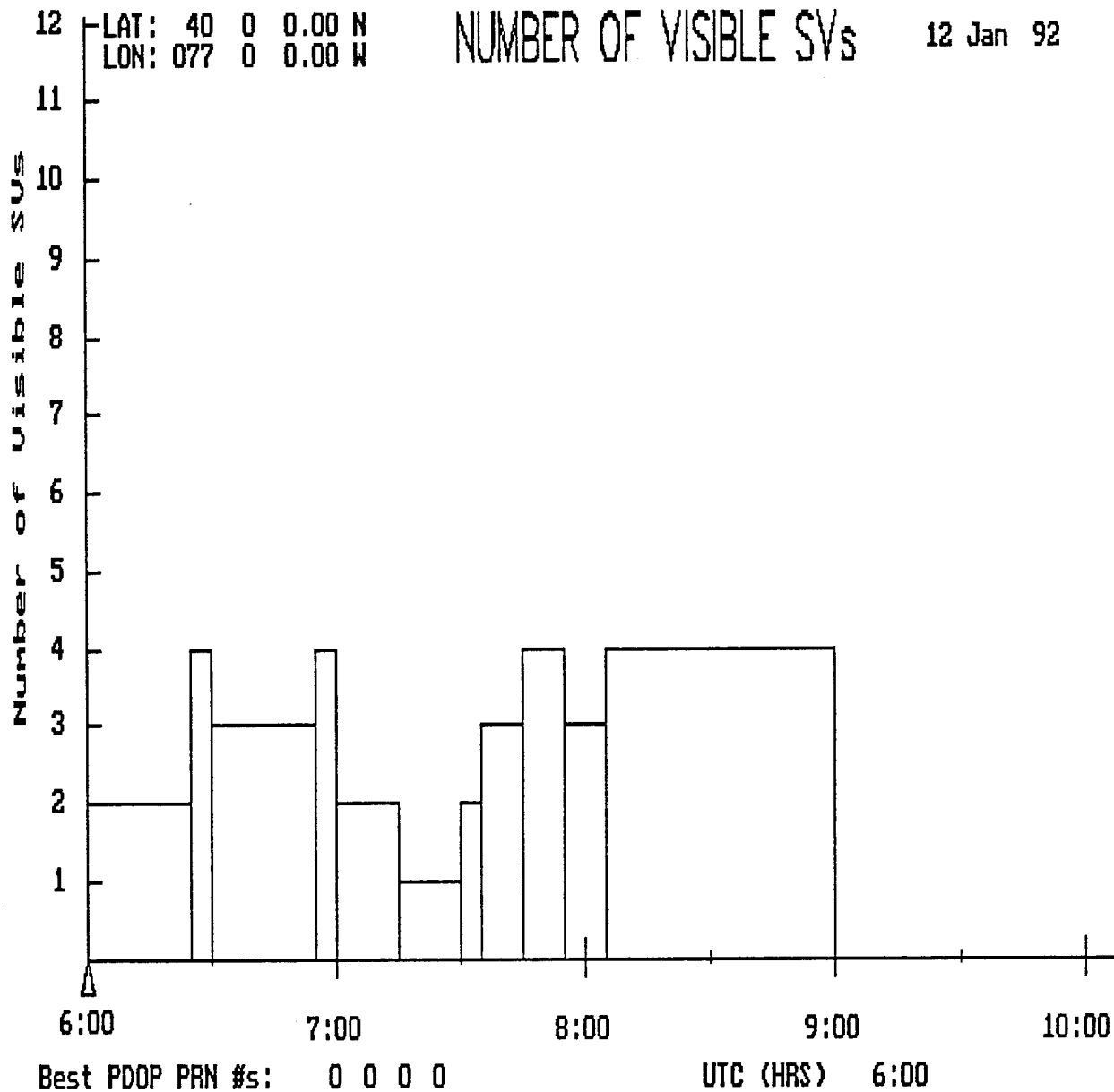

Figure B-11. Number of Visible Satellites At Mid-Latitudes.
 Mask Angle of 60 Degrees.

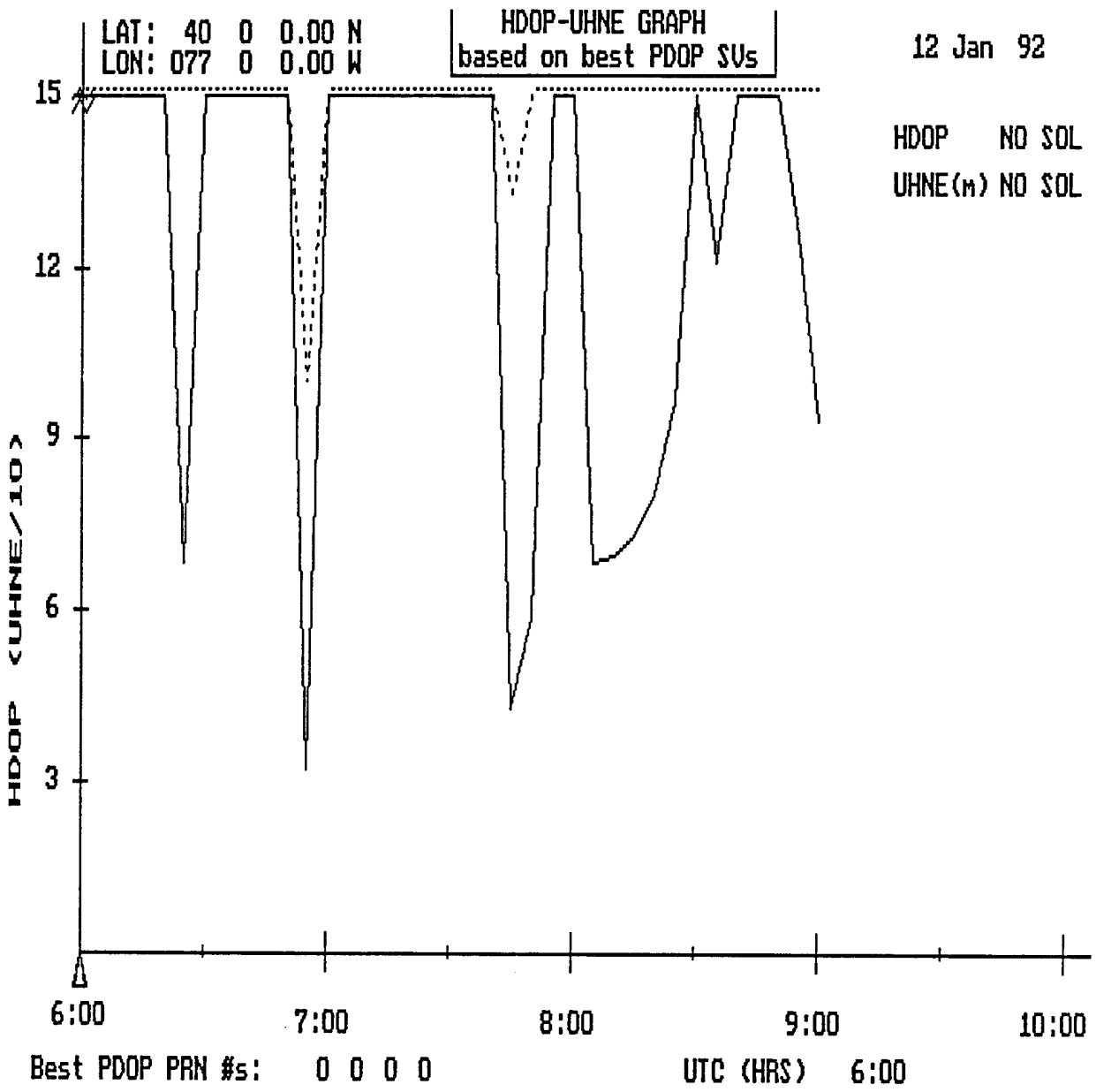

Figure B-12. HDOP At Mid-Latitudes.
Mask Angle of 60 Degrees.(NO SOLUTION FOR PDOP)

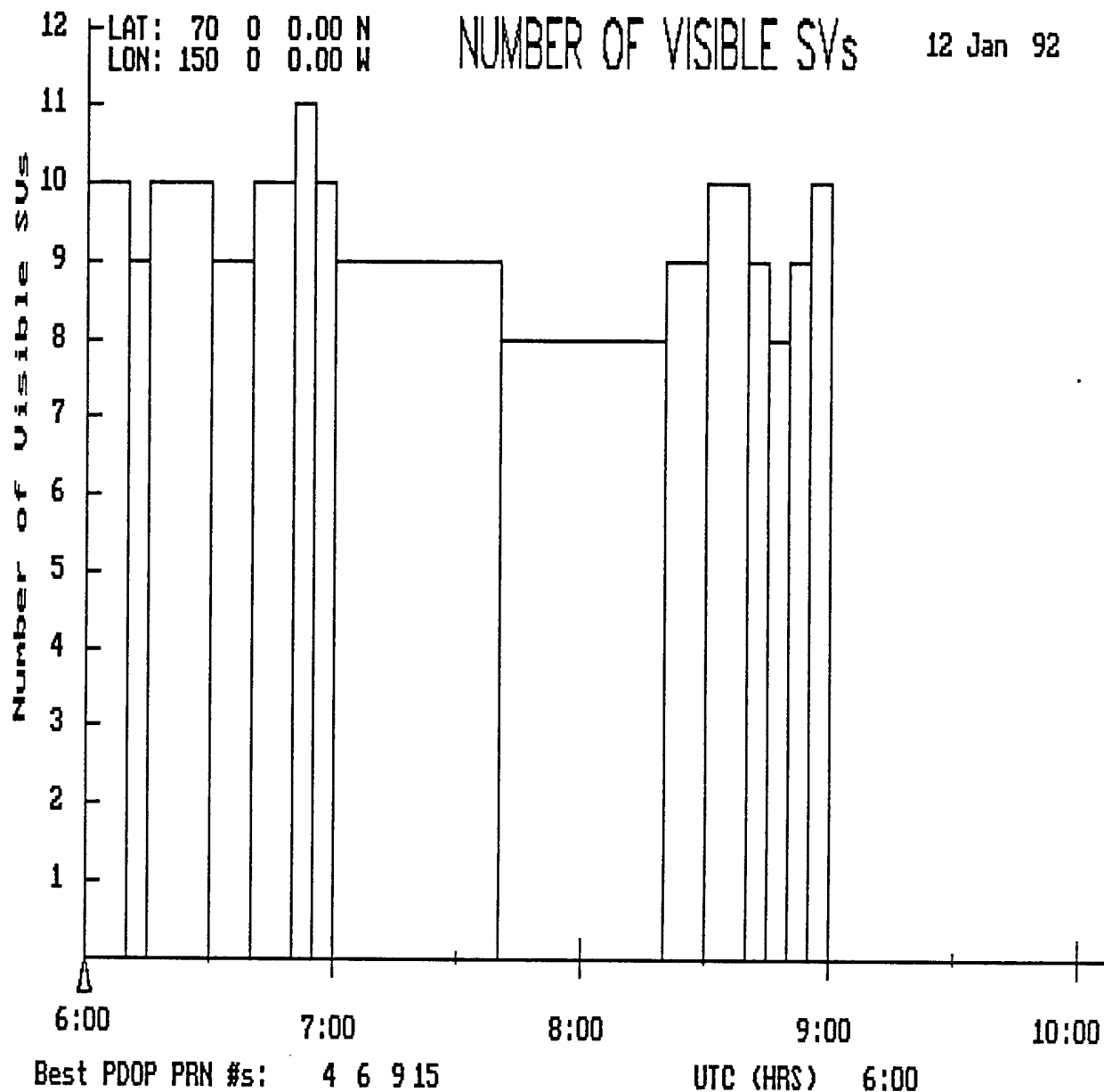

Figure B-13. Number of Visible Satellites At High-Latitudes.
Mask Angle of 30 Degrees.

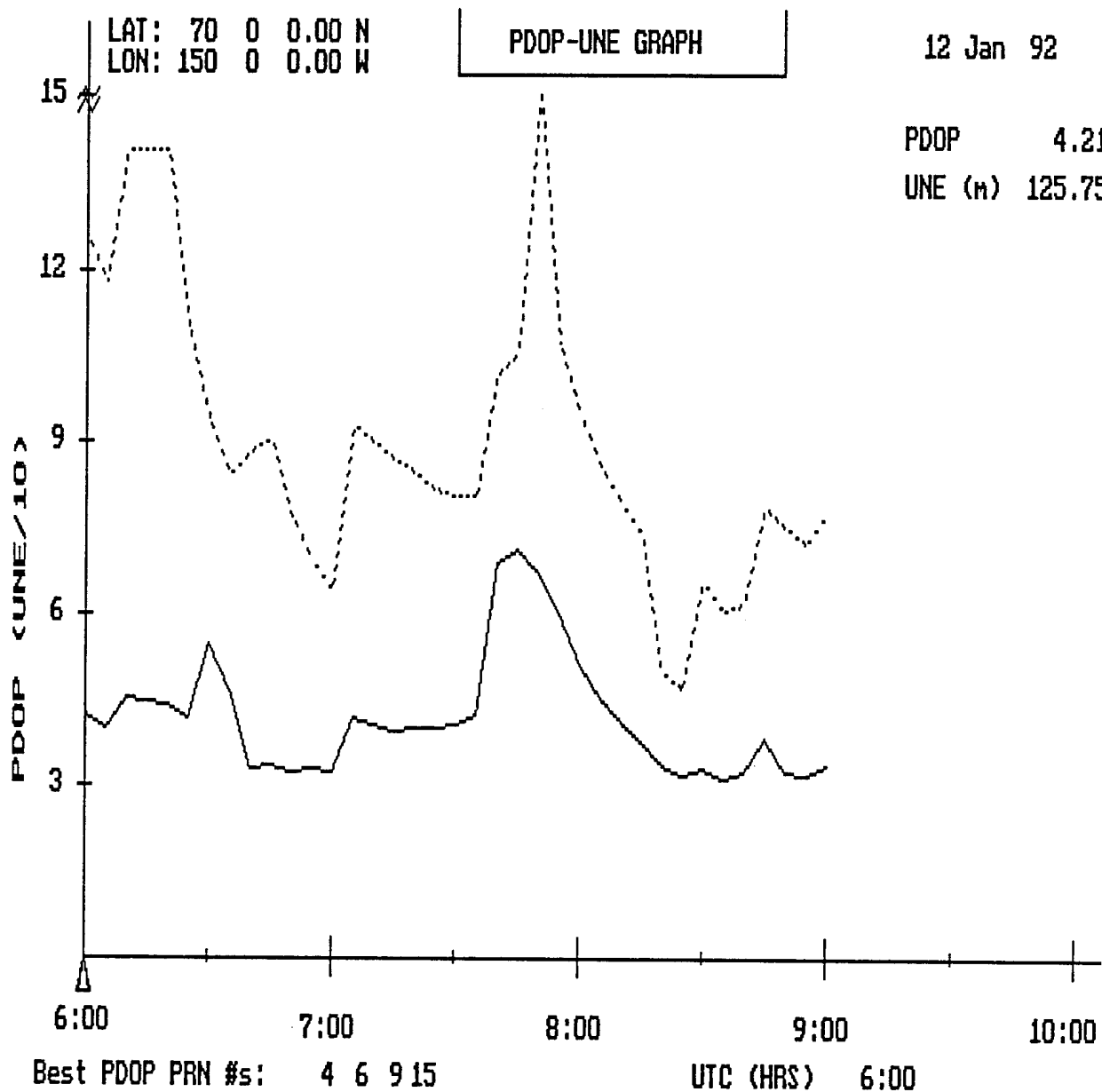

Figure B-14. PDOP At High-Latitudes.
Mask Angle of 30 Degrees.

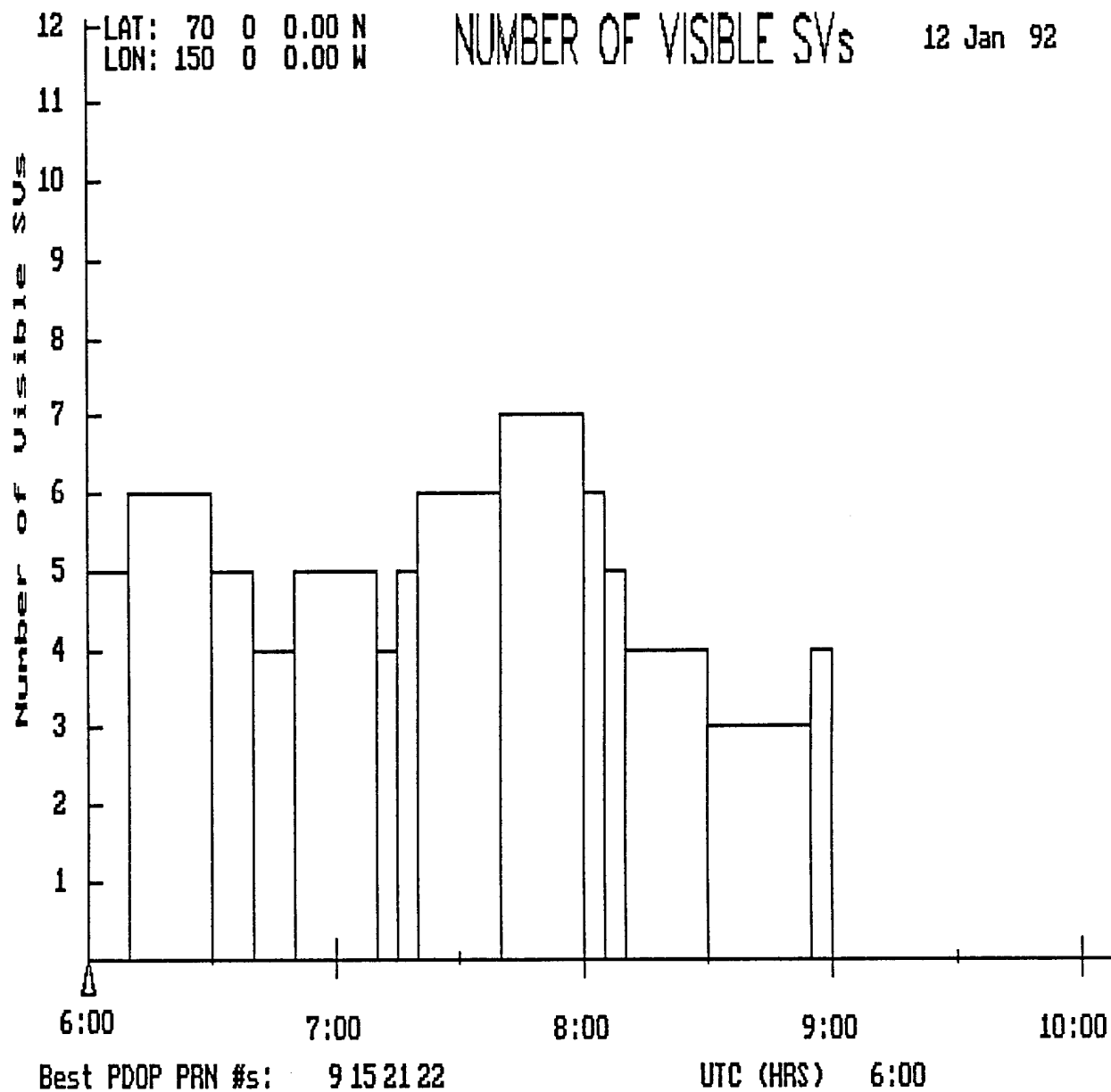

Figure B-15. Number of Visible Satellites At High-Latitudes.
Mask Angle of 45 Degrees.

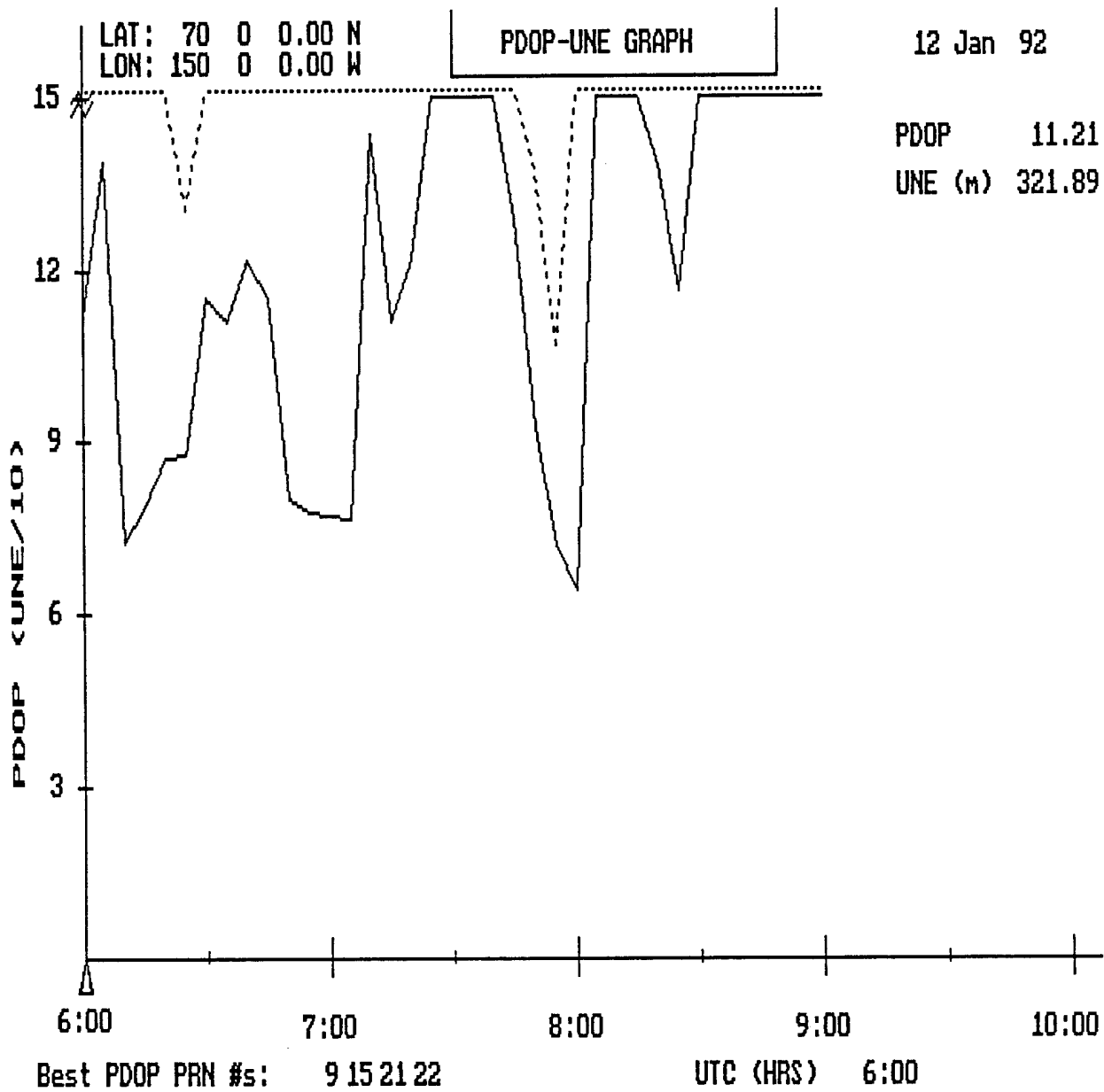

Figure B-16. PDOP At High-Latitudes.
 Mask Angle of 45 Degrees.

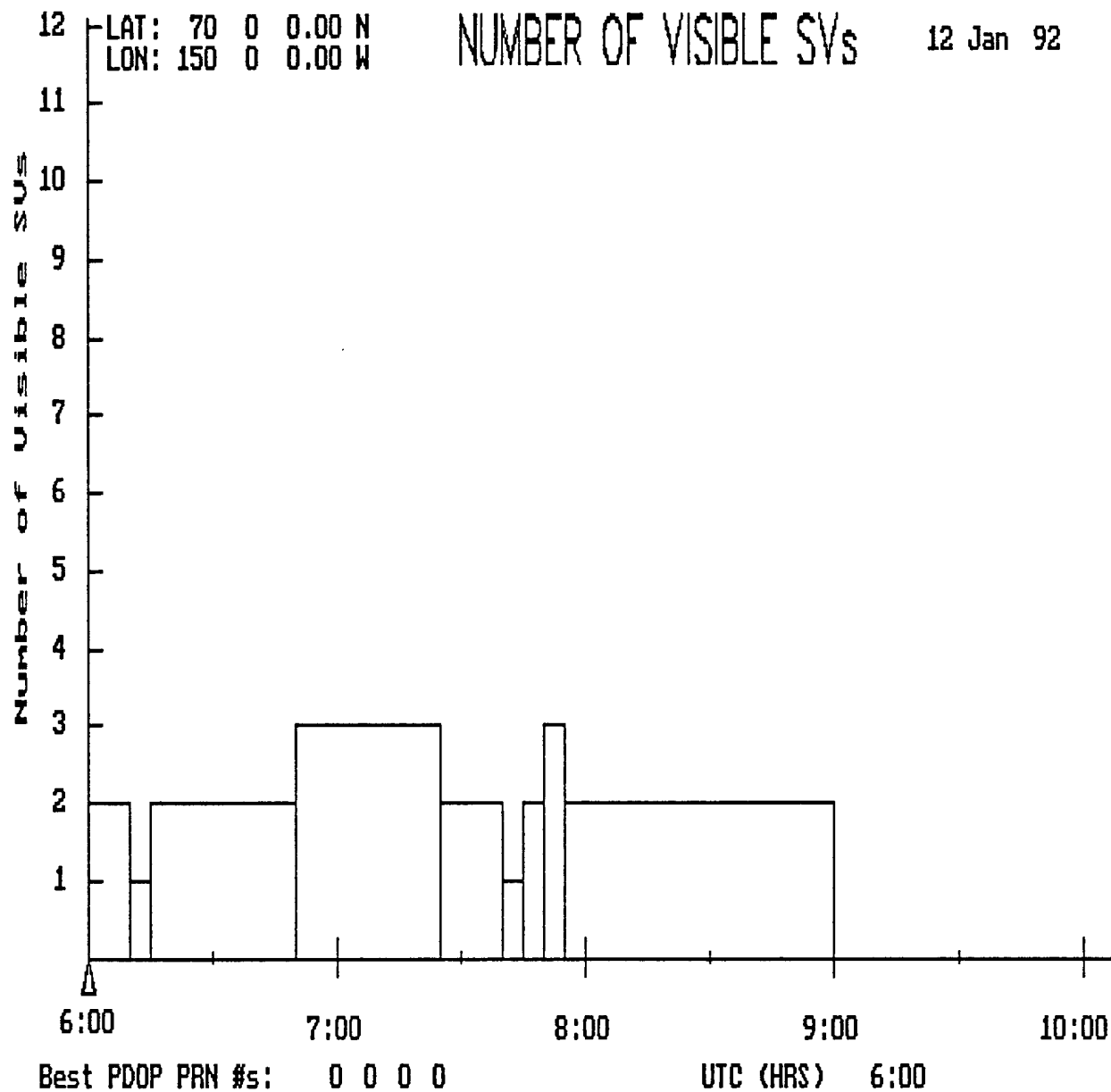

Figure B-17. Number of Visible Satellites At High-Latitudes.
Mask Angle of 60 Degrees.

NO SOLUTION FOR PDOP SINCE NOT ENOUGH SATELLITES ARE VISIBLE

Figure B-18. PDOP At High-Latitudes.
Mask Angle of 60 Degrees.